



FUEGO

HAZARDOUS LOCATION HEATER

3A6713B EN

Thermostat controlled heater for solvent extraction processing.

For use with Ethanol
240VAC Electric-Powered
5400 Watts
Rated MAWP: 7250-PSI

For professional use only.



Important Safety Instructions
Read all warnings and instructions in this manual.
Save these instructions.

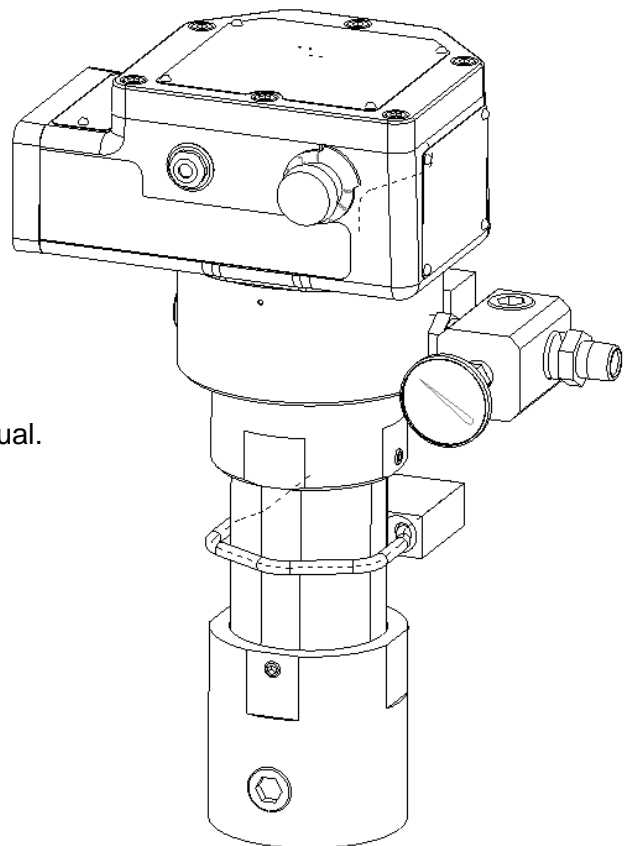

Contents

Models & Agency Approvals	3	Troubleshooting	11
Hazardous Location Heaters	3	Repair	12
Warnings	4	Thermostat & Probe	12
Component Identification	6	Overtemperature Switch	12
Installation	7	Control Knob	12
Electrical Connections	7	Replace Heater Core and Unclog Fluid	
Grounding	8	Passage	14
Hazardous Area Cabling and Conduit		Heater Cartridges	15
Requirements	8	Parts	16
Operation	9	Hazardous Location Heaters 140 and 240	16
Pressure Relief Procedure	9	Performance Charts	18
Initial Flushing	9	Technical Data	19
Setting Heater Control	9	Dimensions	19
Maintenance	10	MVP Standard Warranty	20
Flushing	10	MVP Information	20
Drain the Heater	10		











Models & Agency Approvals

Hazardous Location Heaters

Model	Description	VAC (50/60 Hz single phase) / Watts / Amps	Approvals
26C448	Thermostat Control, 240°F	240 / 5400 / 22.5	 <p data-bbox="1031 556 1209 703"> Intertek 9902471 Class I, Division 1, Groups C, D (T3) -20°C < T a < +60°C </p>

Warnings

The following warnings are for the setup, use, grounding, maintenance, and repair of this equipment. The exclamation point symbol alerts you to a general warning and the hazard symbols refer to procedure-specific risks. When these symbols appear in the body of this manual or on warning labels, refer back to these Warnings. Product-specific hazard symbols and warnings not covered in this section may appear throughout the body of this manual where applicable.

 <h1 style="margin: 0;">WARNING</h1>	
	<p>SPECIAL CONDITIONS FOR SAFE USE</p> <ul style="list-style-type: none"> For information on the required dimensions of the flameproof joints contact the holder of this certificate; Flamepath joints are not intended to be repaired. Special fasteners for securing equipment covers shall have a minimum yield strength of 1,100 MPa and be corrosion resistant and sized M8 x 1.25 x 30.
 	<p>ELECTRIC SHOCK HAZARD</p> <p>This equipment must be grounded. Improper grounding, setup, or usage of the system can cause electric shock.</p> <ul style="list-style-type: none"> Turn off and disconnect power at main switch before disconnecting any cables and before servicing or installing equipment. Connect only to grounded power source. All electrical wiring must be done by a qualified electrician and comply with all local codes and regulations.
	<p>BURN HAZARD</p> <p>Equipment surfaces and fluid that is heated can become very hot during operation. To avoid severe burns:</p> <ul style="list-style-type: none"> Do not touch hot fluid or equipment.
   	<p>FIRE AND EXPLOSION HAZARD</p> <p>Flammable fumes in work area can ignite or explode. Solvent flowing through the equipment can cause static sparking. To help prevent fire and explosion:</p> <ul style="list-style-type: none"> Use equipment only in well-ventilated area. Eliminate all ignition sources; such as pilot lights, cigarettes, portable electric lamps, and plastic drop cloths (potential static sparking). Ground all equipment in the work area. See Grounding instructions. Never spray or flush solvent at high pressure. Keep work area free of debris, including solvent, rags and gasoline. Do not plug or unplug power cords, or turn power or light switches on or off when flammable fumes are present. Use only grounded hoses. Stop operation immediately if static sparking occurs or you feel a shock. Do not use equipment until you identify and correct the problem. Keep a working fire extinguisher in the work area. Never operate with covers removed. Do not open when energized. Install conduit within 18 in (457 mm). Do not install if operating temperature exceeds ignition temperature of hazardous atmosphere.
	<p>PERSONAL PROTECTIVE EQUIPMENT</p> <p>Wear appropriate protective equipment when in the work area to help prevent serious injury, including eye injury, hearing loss, inhalation of toxic fumes, and burns. Protective equipment includes but is not limited to:</p> <ul style="list-style-type: none"> Protective eyewear, and hearing protection. Respirators, protective clothing, and gloves as recommended by the fluid and solvent manufacturer.



WARNING



EQUIPMENT MISUSE HAZARD

Misuse can cause death or serious injury.

- Do not operate the unit when fatigued or under the influence of drugs or alcohol.
- Do not exceed the maximum working pressure or temperature rating of the lowest rated system component. See **Technical Data** in all equipment manuals.
- Use fluids and solvents that are compatible with equipment wetted parts. See **Technical Data** in all equipment manuals. Read fluid and solvent manufacturer's warnings. For complete information about your material, request Safety Data Sheets (SDSs) from distributor or retailer.
- Do not leave the work area while equipment is energized or under pressure.
- Turn off all equipment and follow the **Pressure Relief Procedure** when equipment is not in use.
- Check equipment daily. Repair or replace worn or damaged parts immediately with genuine manufacturer's replacement parts only.
- Do not alter or modify equipment. Alterations or modifications may void agency approvals and create safety hazards.
- Make sure all equipment is rated and approved for the environment in which you are using it.
- Use equipment only for its intended purpose. Call your distributor for information.
- Route hoses and cables away from traffic areas, sharp edges, moving parts, and hot surfaces.
- Do not kink or over bend hoses or use hoses to pull equipment.
- Keep children and animals away from work area.
- Comply with all applicable safety regulations.



PRESSURIZED ALUMINUM PARTS HAZARD

Use of fluids that are incompatible with aluminum in pressurized equipment can cause serious chemical reaction and equipment rupture. Failure to follow this warning can result in death, serious injury, or property damage.

- Do not use 1,1,1-trichloroethane, methylene chloride, other halogenated hydrocarbon solvents or fluids containing such solvents.
- Do not use chlorine bleach.
- Many other fluids may contain chemicals that can react with aluminum. Contact your material supplier for compatibility.



THERMAL EXPANSION HAZARD

Fluids subjected to heat in confined spaces, including hoses, can create a rapid rise in pressure due to the thermal expansion. Over-pressurization can result in equipment rupture and serious injury.

- Open a valve to relieve the fluid expansion during heating.
- Replace hoses proactively at regular intervals based on your operating conditions.



Component Identification

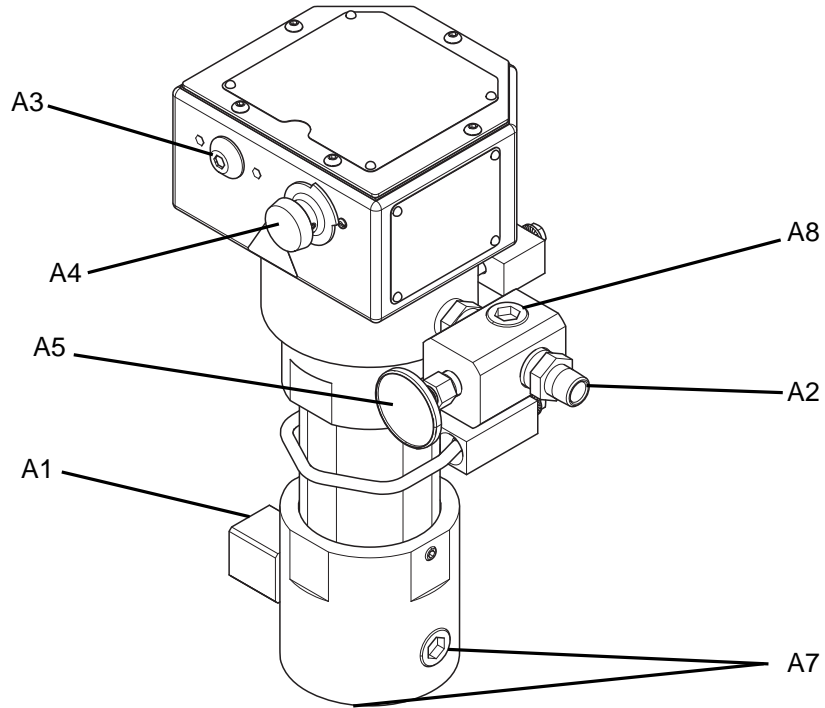

ti20051a

Key:

- A1 Fluid Inlet
- A2 Fluid Outlet
- A3 Heater ON Indicator Light
- A4 Temperature Control Knob
- A5 Temperature Gauge
- A7 Optional Inlet Ports (front and bottom)
- A8 Optional Outlet Ports (one on outlet manifold and one on opposite side of heater)

Installation

<ul style="list-style-type: none"> Select system components that meet temperature and pressure ratings listed in Technical Data, page 20. The normal output range of the heater can be adjusted from 84-220°F (29-104°C). To prevent fire and explosion, locate heater away from all flammable materials and where operators will not come in contact with hot metal surfaces. To avoid burns, insulate and/or label lines and components exiting heater that may become hot. To help prevent fire and explosion, do not use heater with hydrocarbon solvents, such as propane and butane. 				

NOTICE

The inlet fluid temperature cannot exceed 275°F (135C). This will cause the heater to exceed its rated temperature code.

1. Install a fluid shutoff valve (T) in the heater's 3/4 in. npt(m) fluid inlet. Do not overtighten. Connect the fluid supply line to the valve.

<p>To prevent serious injury caused by component or equipment rupture:</p> <ul style="list-style-type: none"> Never install a shutoff device between the heater and gun as this will trap the heated fluid and not allow for expansion. Never use a fluid regulator as a shutoff device if it is installed between the heater and gun Provide a means for adequately handling fluid expansion caused by heat. 				

To handle fluid expansion caused by heat:

- Use flexible hoses between heater and application.
- Install a properly sized accumulator downstream from the heater.
- Install a pressure relief valve (X) pre-set to relieve pressure when it exceeds the system maximum working pressure.

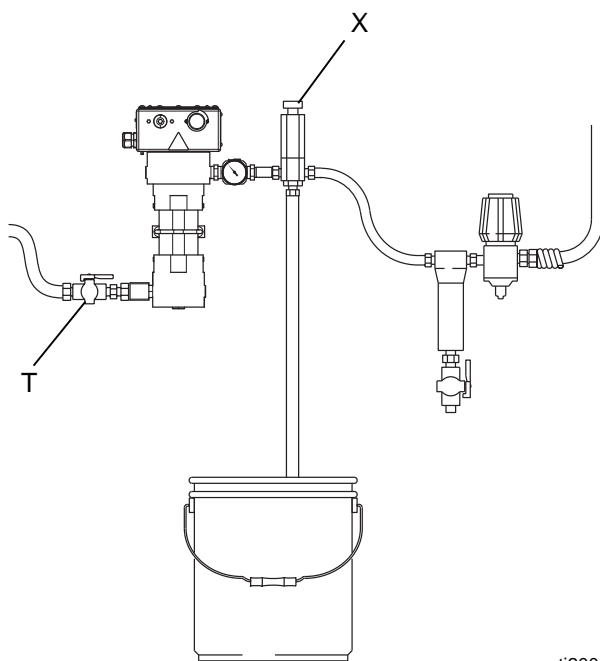

ti20056a

Fig. 1: Installation

Mounting

NOTE: Heater controls must be easily accessible.

NOTE: The mounting surface must be able to support the weight of the heater and fluid and any stress caused during operation.

See **Dimensions**, page 19 for mounting hole spacing.

Electrical Connections

<p>Improper wiring may cause electric shock or other serious injury if work is not performed properly</p> <ul style="list-style-type: none"> This equipment must be grounded. Connect only to a grounded power source. All electrical wiring must be done by a qualified electrician and comply with all local codes and regulations. 				

NOTICE

To help prevent damage, avoid spilling liquids onto electrical components and never operate with the cover removed or screws missing.

Requirements For All Installations

- See **Models & Agency Approvals**, page 3 for power requirements. The heater requires a dedicated circuit protected with a circuit breaker.
- Power conductors used for supply connection must be 10 AWG or larger and suitable for at least 221°F (105°C). An intermediate Type “e” junction may be required.
- Make your electrical ground connection to the green ground screw inside the control head.
- Make your power connections to the two post bushings in the control head. Refer to the applicable schematic on page 13. Power entry should be connected through the 3/4 npt port. Follow **Hazardous Area Cabling and Conduit Requirements**, page 8.

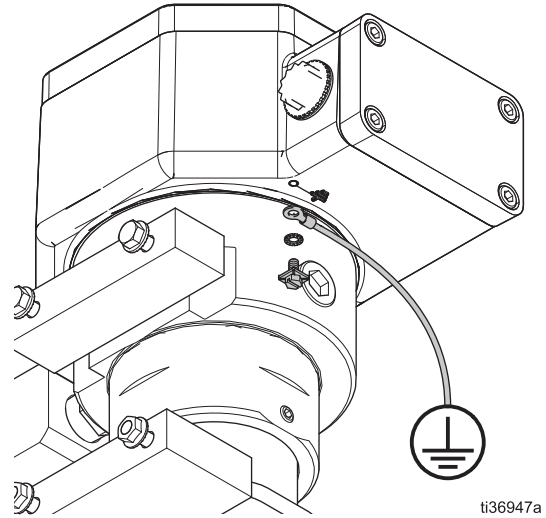

FIG. 2: External Ground Wire

Grounding

<p>The equipment must be grounded to reduce the risk of static sparking and electric shock. Electric or static sparking can cause fumes to ignite or explode. Improper grounding can cause electric shock. Grounding provides an escape wire for the electric current.</p>				

1. Connect the electrical supply ground wire to the green ground screw inside the heater electrical compartment. See FIG. 5 and FIG. 6.
2. Connect a ground wire to the external ground screw. Loosen the ground screw and attach a ground wire. See FIG. 2. Tighten the ground screw securely. Connect the other end of the ground wire to a true earth ground.

Hazardous Area Cabling and Conduit Requirements



Explosion Proof

All electrical wiring in the hazardous area must be encased in Class I, Division I, Groups C1 and D approved explosion-proof conduit. Follow all National, State, and Local electric codes.

A conduit seal (D) is required within 18 in. (457 mm) of the heater for the US and Canada. All cables must be rated at 221°F (105°C).

Operation

Pressure Relief Procedure



Follow the Pressure Relief Procedure whenever you see this symbol.



This equipment stays pressurized until pressure is manually relieved. To help prevent serious injury from pressurized fluid, and splashing fluid, follow the Pressure Relief Procedure when you stop operating and before cleaning, checking, or servicing the equipment.

1. Shut off main power to the heater.
2. Circulate fluid for at least 10 minutes to cool the heated fluid and heater.
3. Shut off all air and fluid supplies.
4. Open fluid valves downstream of the heater.

Initial Flushing



To avoid fire and explosion:

- Flush equipment only in a well-ventilated area
- Ensure main power is off and heater is cool before flushing
- Do not turn on heater until fluid lines are clear of solvent

The heater was tested with lightweight oil, which needs to be flushed out before using the equipment. Use a compatible solvent, and follow flushing instructions in your fluid supply and application manuals.

Setting Heater Control

Adjusting the flow rate through the heater will also affect the fluid temperature.

1. Set the heater control knob (33) to a trial setpoint of 4 or 5.
2. Start the pump and circulate fluid through the system.
3. After the indicator light turns off: read the temperature on the thermometer (2). If it does not match the desired temperature, adjust the setpoint.

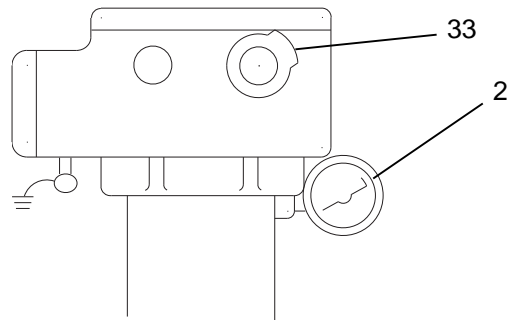



05549

FIG. 3: Setting Heater Control

Maintenance

Flushing

				
<p>To avoid fire and explosion:</p> <ul style="list-style-type: none"> • Flush equipment only in a well-ventilated area • Ensure main power is off and heater is cool before flushing • Do not turn on heater until fluid lines are clear of solvent 				

Clogged fluid passages reduce heating efficiency, flow rate, and pressure. Flush or clean whenever a change in heating efficiency, flow rate, or pressure is noticed.

1. Follow **Pressure Relief Procedure**, page 9.
2. Ensure main power is off and heater is cool before flushing. Use a compatible solvent, and follow flushing instructions in your extractor system manual. **Do not turn on heater until fluid lines are clear of solvent.**

Drain the Heater

				
---	--	---	--	--

1. Follow **Pressure Relief Procedure**, page 9.
2. Remove heater inlet and outlet fittings or pipe plugs. Have a container ready to catch the fluid.

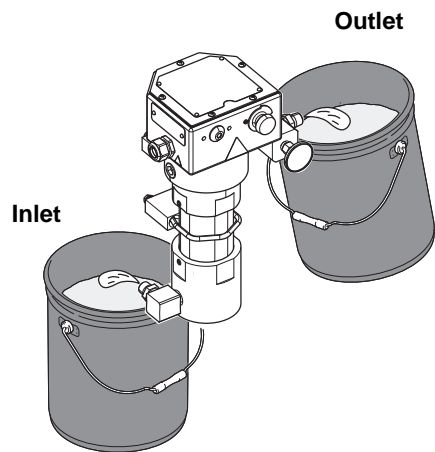

ti20057a







FIG. 4: Drain the Heater

Troubleshooting



Problem	Cause	Solution
Heater will not heat.	No current.	Check circuit and fuses.
	Overtemperature switch (10) tripped.	<ul style="list-style-type: none"> Check continuity of overtemperature switch. If circuit is open, press red reset switch and re-check. Determine why switch opened before restarting. Check that the thermostat (24) is open when the knob is turned to the left and closed when turned to the right.
	Burned out heater cartridges (81).	Replace cartridges.
Temperature too low.	Fluid requires more warm-up time.	Increase warm-up time.
	Wrong temperature setting.	Adjust setting, page 9.
	Flow rate too high.	Reduce flow rate or use 2 heaters.
	Clogged fluid passages.	Replace Heater Core and Unclog Fluid Passage , page 14.
	One of the two heater cartridges (81) failed.	Check each cartridge for a resistance of approximately 21 ohms. The pair in parallel should have a resistance of approximately 10.7 ohms. See Heater Cartridges on page 15.
Temperature too high.	Wrong temperature setting.	Adjust setting, page 9.
	Failed primary thermostat (24).	Replace, page 12.
High fluctuating temperatures, about 220-250°F (104-120°C) at 0.1 GPM.	Primary thermostat (24) contacts sticking.	Replace thermostat (24), page 12.
Too much pressure drop or fluid will not flow.	Flow rate too high.	Reduce flow rate or use 2 heaters.
	Clogged fluid passages.	Flush or clean, page 10.
Heater fittings leak.	Loose or damaged fittings.	Tighten or replace fittings.
Heater temperature rises far beyond the setpoint temperature during heating	Heater core is dirty or has baked on material.	Disassemble and clean all parts that come in contact with material.

Repair

To avoid burns, electric shock, and skin injection, make sure the main power is OFF, heater is cool, and pressure is relieved before repairing.

Thermostat & Probe

(See FIG. 5 on page 13)

1. Perform **Pressure Relief Procedure**, page 9.
2. Remove screws (52) then remove housing cover (18).
3. Loosen screws (25) that secure thermostat in place.
4. Remove wires from the thermostat terminals (FF).
5. Loosen setscrew (26) in switch shaft (28)
6. Pull thermostat probe (EE) out of heater block.
7. Remove thermostat (24) from housing (1).
8. Remove screw standoff (35) with washer (27).
9. Remove bracket from thermostat (24) and secure to new thermostat.

NOTICE

To avoid damaging capillary tube (GG) of the thermostat, which can cause heater malfunction, do not kink or nick the tube.

To avoid shorting out the heater, do not allow capillary tube to contact the terminals on switch (10) or thermostat (24). Follow step 10, below.

10. Liberally apply thermal lubricant to probe (EE) of new thermostat (24). Loop capillary tube (GG) several times and wrap the loops with tie strap (42-not shown). Insert probe in the heater block.
11. Continue reassembling in reverse order of disassembly. See the following **Reassembly Notes** section.

Overtemperature Switch

NOTE: This switch is a manual reset type. Press the red button to reset the switch. Check for continuity across the contacts. If the switch tripped, always determine the cause before returning the heater to service.

1. Follow **Pressure Relief Procedure**, page 9.
2. Remove screws (52) then remove housing cover (18).
3. Unplug wires from tabs (HH) on switch.
4. Remove the two screws (16) securing the switch then remove the switch (10).
5. Liberally apply thermal lubricant to the bottom of the thermostat switch and reinstall it in reverse order of disassembly.

Reassembly Notes

- Refer to FIG. 6 for wiring connections.
- Make sure gasket (47) is installed and aligned with electrical housing screw holes.
- Secure cover (18) with screws (52). Torque screws to 89 in-lb (10 N•m).

Control Knob

See the **Parts** illustration on page 16.

1. Follow **Pressure Relief Procedure**, page 9.
2. Turn control knob (33) to setpoint 1.
3. Loosen the control knob setscrew (30).
4. Remove control knob.
5. Remove adjusting knob (12) from the control knob and press fit it onto the new control knob. Check the grommet (29) and replace if worn.
6. Position new knob so setpoint 1 aligns with the 12 o'clock position and the knob is about 1/16 in. (1 mm) away from the housing. Install and tighten setscrew (30).

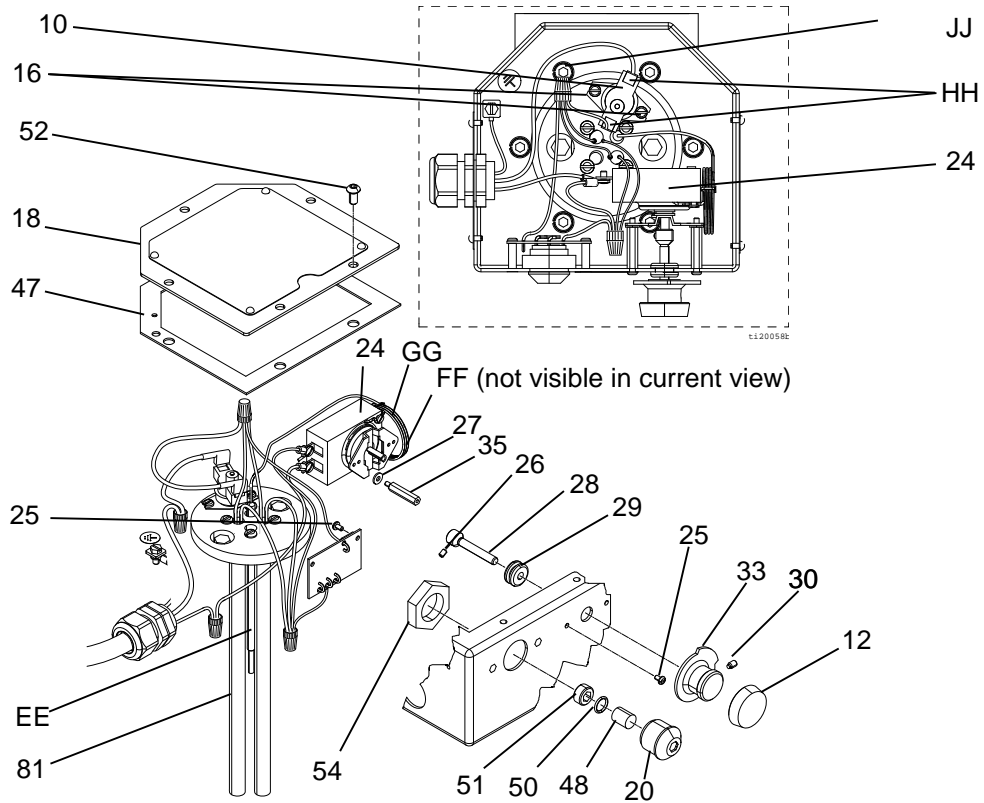

FIG. 5: Thermostat Repair

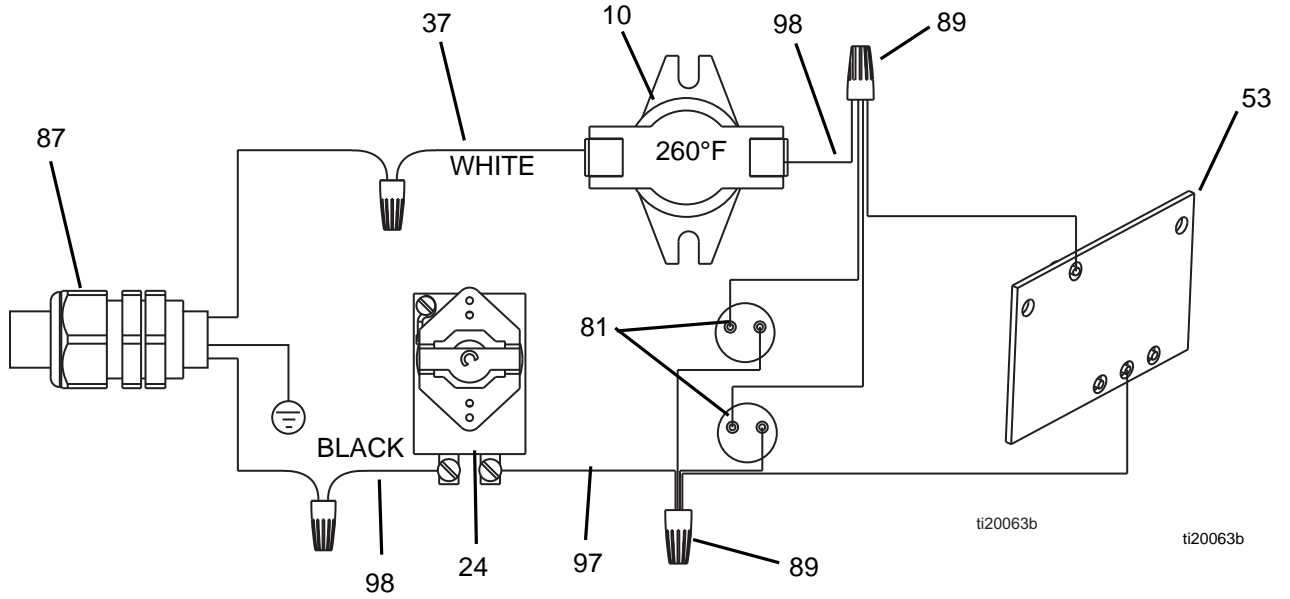

FIG. 6: Electrical Schematic

Replace Heater Core and Unclog Fluid Passage

The heater core (68) can be removed for thorough cleaning or replacement. See the **Parts** illustration that applies to your heater on page 16.

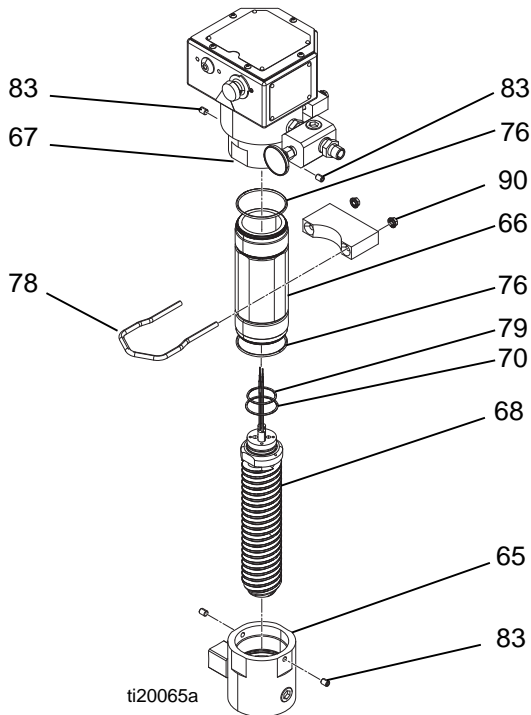

FIG. 7

1. Follow **Pressure Relief Procedure**, page 9.
2. Disconnect power.
3. Wait for system to cool.
4. **Drain the Heater**, page 10.
5. Loosen set screws (83) from bottom inlet housing with a 3/16 in. hex key.
6. Unscrew bottom inlet housing (65).
7. Remove nuts (90) then remove cylinder u-bolt clamp (78).
8. Loosen set screws (83) on upper fluid housing (67).
9. Unscrew cylinder (66). Pull down to remove.
10. Remove screws (52) then remove cover (18).
11. Remove 4 screws (71) from top of plate (69).

12. Disconnect heater cartridge (81) wire leads from wire nuts (89).

NOTICE

To prevent damage to sensors and wiring, do not turn core (68). The core pushes straight down out of housing (67).

13. Pull heater core straight down out of the upper housing (67).
14. Use a wire brush to clean outside fluid passages until bare aluminum is visible.

NOTE: The capillary bulb/tube from the thermostat (24) will slowly pull out of its hole in the core (68). The heater core wires will pull down through plate (69).

Reassembly Notes

- Always replace o-rings (70, 76, and 79).
- Refer to FIG. 5 for wiring connections.
- Make sure gasket (47) is installed and aligned with electrical housing screw holes.
- Secure cover (18) with screws (52). Torque screws to 85-90 in-lb (10 N•m).

Heater Cartridges

See **Parts** illustration on page 16.

1. Follow **Pressure Relief Procedure**, page 9.
2. Disconnect power.
3. **Drain the Heater**, page 10.
4. Perform **Replace Heater Core and Unclog Fluid Passage** procedure on page 14. This includes removing the inlet housing (65).
5. With the inlet housing removed, remove 5 screws (52) and cover (18).
6. Disconnect wires from heater cartridges (81).
7. Remove pipe plug (95) and springs (31) from bottom of core (68).
8. Use a 3/8 in. (10 mm) rod to push each cartridge out of the top of the core.
9. Wire new cartridges per FIG. 6, page 13.

Parts

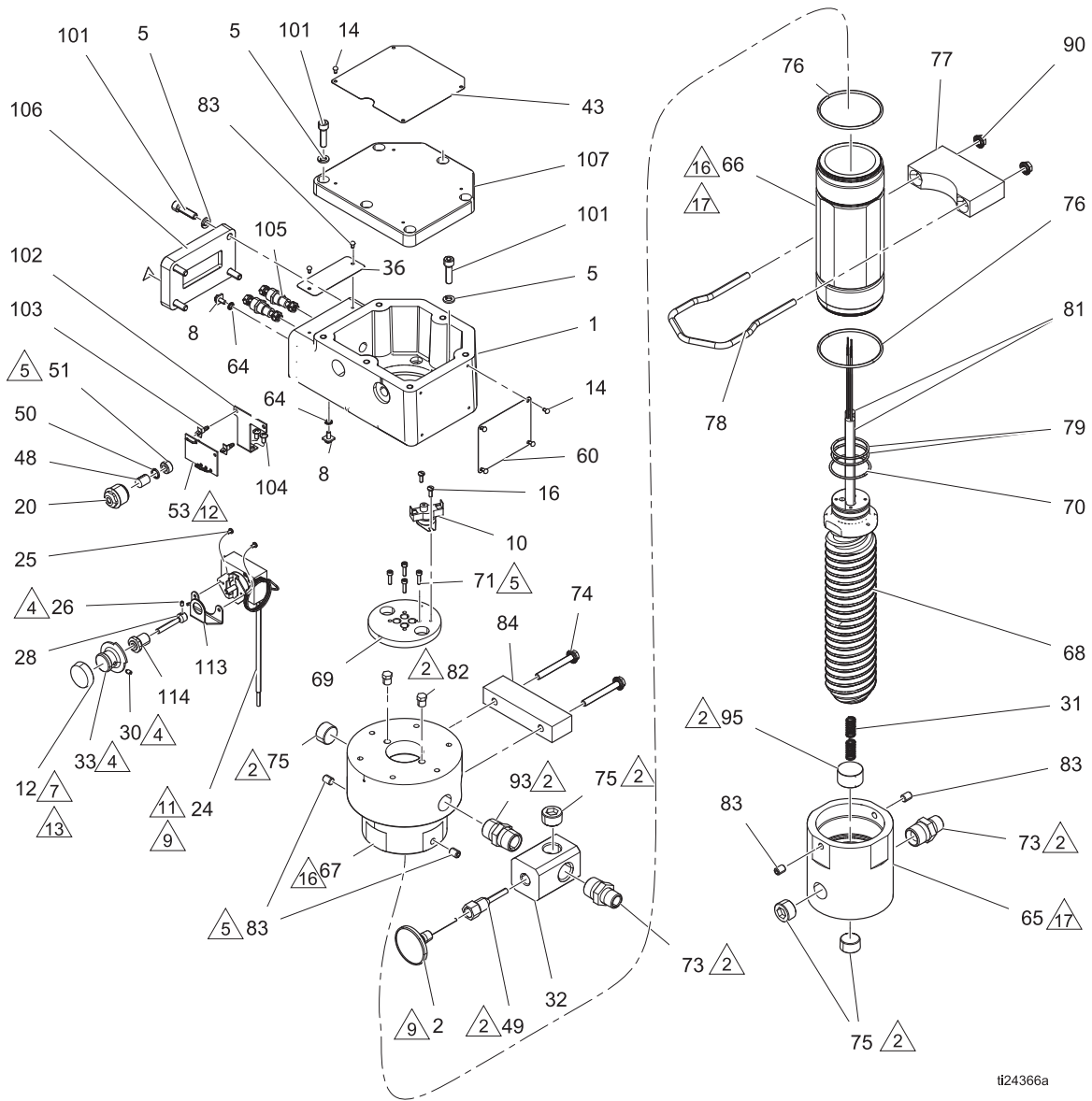

ti24366a

Apply sealant (39) and tape (44).

Torque to 7-11 ft-lb (10-15 N•m).

Loosen setscrew (26). Turn shaft (28) clockwise and re-tighten setscrew (26). Turn shaft counter-clockwise. Install knob (33) with "1" at 12 o'clock position. Tighten knob setscrew (30).

Apply sealant (34).

Apply thermal lubricant (38) to bottom of flange (10).

Press fit onto knob (33).

Apply thermal lubricant (38) completely covering probe before inserting.

Wrap capillary tube of thermostat (24) and attach strap (42). Do not kink or nick tube. Position wrapped capillary tube between thermostat (24) and wall of enclosure (1) maintaining at least 0.6 in. from heating element.

Connect appropriate wire (240V) and terminal end (part of item 53) to heater terminal.

Apply adhesive (56) if required.

Assemble sleeve (66) to housing (67). After bottoming parts together loosen between 0 and 90 degrees to align set screws (83) to sleeve flats (66).

Assemble housing (65) to sleeve (66). After bottoming parts together loosen between 0 and 180 degrees to align set screws (83) to sleeve flats (66).

Ref	Description	Qty	Ref	Description	Qty
1	HOUSING, control	1	77	CLAMP, mounting, bottom, heater	1
2	THERMOMETER, dial	1	78	CLAMP, u-bolt, heater	1
5	WASHER, lock, spring	16	79	PACKING, o-ring	2
8	SCREW, ground	2	81	CARTRIDGE, heater, 2700w, 240v	2
10	THERMOSTAT	1	82	PLUG, stl 1/8 pipe hex hd	2
12	KNOB, adjusting	1	83	SCREW, set, sch	4
14	SCREW, drive, #6	10	84	CLAMP, mounting, top, heater	1
16	SCREW, mach, pnh	2	90	NUT, hex, flange head	2
18	COVER, housing	1	93	FITTING, nipple, 3/4	1
20	HOUSING, light, sightglass	1	95	PLUG, pipe	1
24	SWITCH, thermostat	1	98	WIRE, assembly	1
25	SCREW, mach, pnh	2	101	SCREW, cap, sch	16
26	SCREW, set, sch	1	102	BRACKET, led ckt board mounting	1
28	SHAFT, switch	1	103	SPACER, circuit board mounting	2
30	SCREW, set, sch	1	104	SCREW, mach, phillips pan hd	2
31	SPRING, compression	2	105	BUSHING, post	2
32	FITTING, tee, thermometer, 3/4	1	106	COVER	1
33	KNOB, control	1	113	BRACKET, switch	1
36▲	LABEL, electric shock warning	1	114	BUSHING	1
37	WIRE, assy	2			
38	LUBRICANT, thermal, 1 oz tube	1		--- Not for sale.	
39	SEALANT, pipe, stainless steel	1		▲ Replacement safety labels, tags and cards are available at no cost.	
42	STRAP, tie wiring	1			
43▲	LABEL, multiple warnings	1			
48	LENS, light, glass	1			
49	HOUSING, thermometer	1			
50	PACKING, o-ring	1			
51	SCREW, jam, socket	1			
53	BOARD, ckt, htr ind light assy	1			
60▲	LABEL, warning	1			
64	WASHER, lock, external	2			
65	HOUSING, inlet, heater	1			
66	SLEEVE, center, heater	1			
67	HOUSING, outlet, heater	1			
68	CORE, spiral, heater	1			
69	PLATE, mounting, heater	1			
70	PACKING, o-ring	1			
71	SCREW, mach, rdh	4			
73	FITTING, nipple, reducing, 3/4 x 1/2	2			
74	SCREW, mach, serrated hex head; 5/15-18 x 2.5 in	2			
75	PLUG, pipe headless	4			
76	PACKING, o-ring, ptf, 235	2			

Performance Charts

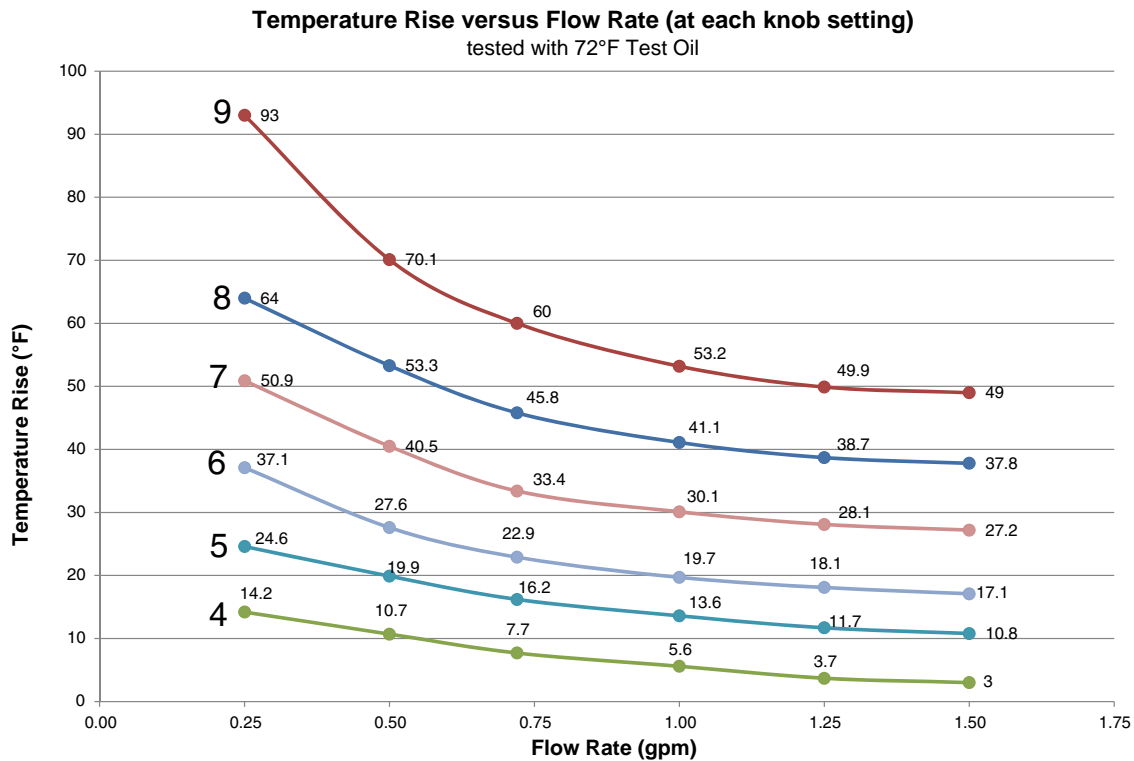
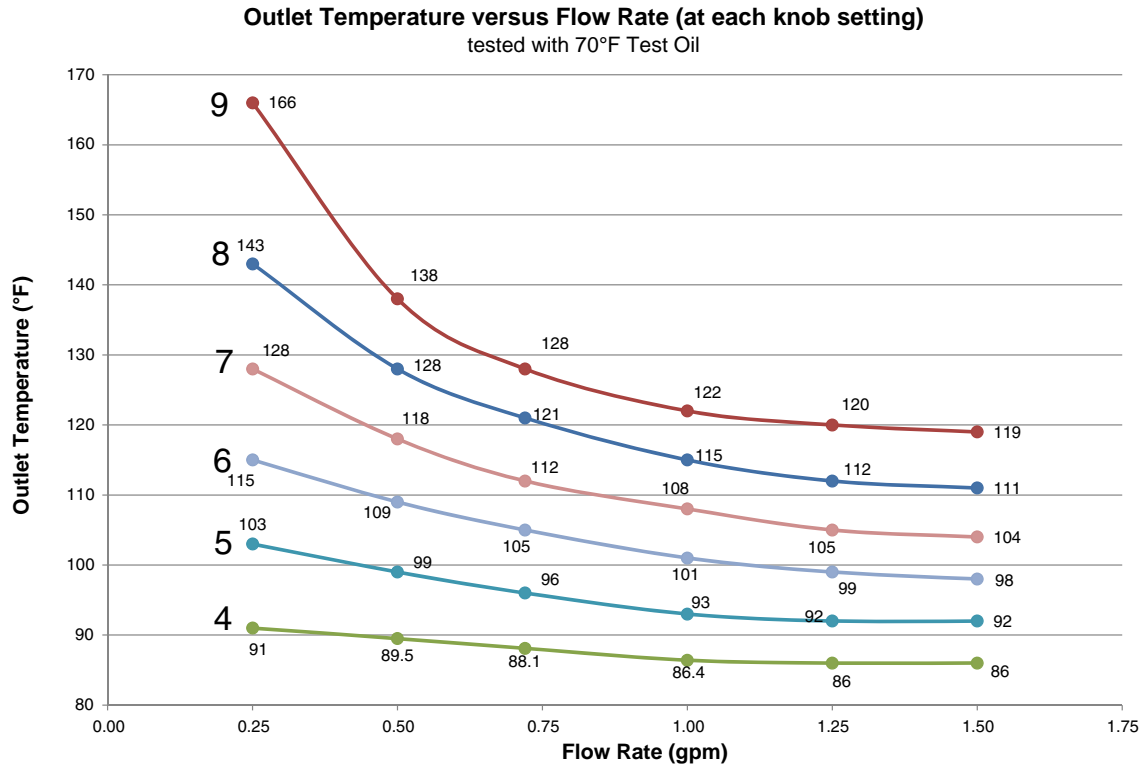

Technical Data

The heater can be used in the following environmental conditions: indoor use, 99% maximum relative humidity, maximum ambient temperature 140° F (60° C).

Maximum Working Pressure	7250 psi (50 MPa, 500 bar)
Voltage / Wattage / Current*	240 VAC (50/60 Hz, single phase) 5400 Watts 22.5 Amps
Fluid Passage Heat Transfer Area	210 in. ² (1355 cm ²)
Fluid Passage Dimensions (3 parallel paths)	Height: 0.41 in. Width: 0.32 in. Length: 3 x 48 in.
Fluid Passage Equivalent Diameter	0.72 in. (18.3 mm)
Thermometer Range	64 - 250°F (18 - 121°C)
Wetted Parts	Stainless Steel, Anodized Aluminum, Electroless Nickel-Plated Steel, PTFE
Temperature Operating Range	84 - 219°F (29 - 104°C)
Weight	51 lb (23.2 kg)

* Main supply fluctuation not to exceed 10%.

Dimensions

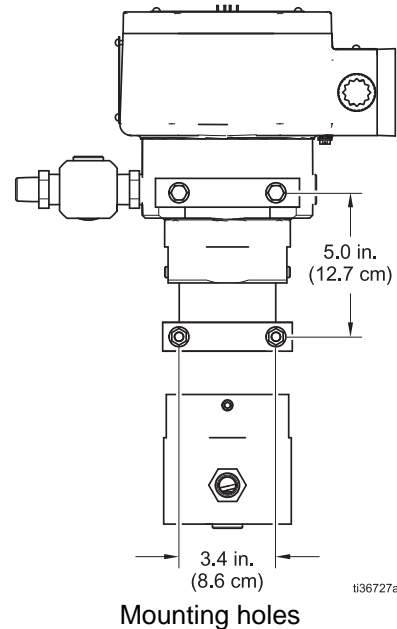
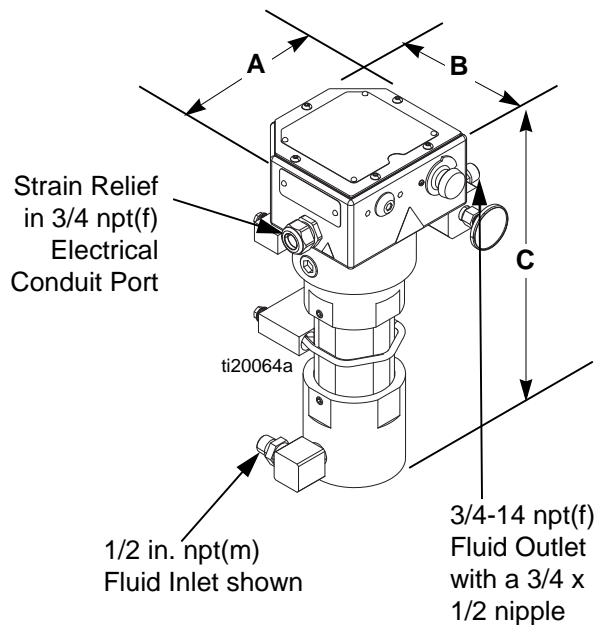

NOTE:

- Lower inlet housing can be turned to face the front, back, left, or right.

Measurements

A	B	C
7.25 in (184 mm)	7.0 in (178 mm)	17.75 in (451 mm)

MVP Standard Warranty

MVP warrants all equipment referenced in this document which is manufactured by MVP and bearing its name to be free from defects in material and workmanship on the date of sale to the original purchaser for use. With the exception of any special, extended, or limited warranty published by MVP, MVP will, for a period of twelve months from the date of sale, repair or replace any part of the equipment determined by MVP to be defective. This warranty applies only when the equipment is installed, operated and maintained in accordance with MVP's written recommendations.

This warranty does not cover, and MVP shall not be liable for general wear and tear, or any malfunction, damage or wear caused by faulty installation, misapplication, abrasion, corrosion, inadequate or improper maintenance, negligence, accident, tampering, or substitution of non-MVP component parts. Nor shall MVP be liable for malfunction, damage or wear caused by the incompatibility of MVP equipment with structures, accessories, equipment or materials not supplied by MVP, or the improper design, manufacture, installation, operation or maintenance of structures, accessories, equipment or materials not supplied by MVP.

This warranty is conditioned upon the prepaid return of the equipment claimed to be defective to an authorized MVP distributor for verification of the claimed defect. If the claimed defect is verified, MVP will repair or replace free of charge any defective parts. The equipment will be returned to the original purchaser transportation prepaid. If inspection of the equipment does not disclose any defect in material or workmanship, repairs will be made at a reasonable charge, which charges may include the costs of parts, labor, and transportation.

THIS WARRANTY IS EXCLUSIVE, AND IS IN LIEU OF ANY OTHER WARRANTIES, EXPRESS OR IMPLIED, INCLUDING BUT NOT LIMITED TO WARRANTY OF MERCHANTABILITY OR WARRANTY OF FITNESS FOR A PARTICULAR PURPOSE.

MVP's sole obligation and buyer's sole remedy for any breach of warranty shall be as set forth above. The buyer agrees that no other remedy (including, but not limited to, incidental or consequential damages for lost profits, lost sales, injury to person or property, or any other incidental or consequential loss) shall be available. Any action for breach of warranty must be brought within two (2) years of the date of sale.

MVP MAKES NO WARRANTY, AND DISCLAIMS ALL IMPLIED WARRANTIES OF MERCHANTABILITY AND FITNESS FOR A PARTICULAR PURPOSE, IN CONNECTION WITH ACCESSORIES, EQUIPMENT, MATERIALS OR COMPONENTS SOLD BUT NOT MANUFACTURED BY MVP. These items sold, but not manufactured by MVP (such as electric motors, switches, hose, etc.), are subject to the warranty, if any, of their manufacturer. MVP will provide purchaser with reasonable assistance in making any claim for breach of these warranties.

In no event will MVP be liable for indirect, incidental, special or consequential damages resulting from MVP supplying equipment hereunder, or the furnishing, performance, or use of any products or other goods sold hereto, whether due to a breach of contract, breach of warranty, the negligence of MVP, or otherwise.

FOR MVP CANADA CUSTOMERS

The Parties acknowledge that they have required that the present document, as well as all documents, notices and legal proceedings entered into, given or instituted pursuant hereto or relating directly or indirectly hereto, be drawn up in English. Les parties reconnaissent avoir convenu que la rédaction du présente document sera en Anglais, ainsi que tous documents, avis et procédures judiciaires exécutés, donnés ou intentés, à la suite de ou en rapport, directement ou indirectement, avec les procédures concernées.

MVP Information

For the latest information about MVP products, visit MasterVaporPumps.com.
Protected as patented technology.

TO PLACE AN ORDER, contact your MVP distributor or call to identify the nearest distributor.
Toll Free: 1-800-502-3303
Email: info@MasterVaporPumps.com

*All written and visual data contained in this document reflects the latest product information available at the time of publication.
MVP reserves the right to make changes at any time without notice.*

Original instructions. This manual contains English. MM 3A6713

**MVP Headquarters: Santa Cruz
Master Vapor Pumps LLC • 849 Almar Ave., Suite C, #209 • Santa Cruz CA 95060 • USA
Copyright 2018, Master Vapor Pumps LLC.**

MasterVaporPumps.com
Revision A, December 2019