

Operation, Parts

Electric Airless Sprayers



X005493EN

Rev. C

For portable airless spraying of architectural paints and coatings. For professional use only.

Not approved for use in explosive atmospheres or hazardous (classified) locations.

390 Models:

3300 psi (228 bar, 22.8 MPa) Maximum Working Pressure

See page 4 for additional model information.



Important Safety Instructions

Read all warnings and instructions in this manual and related manuals before using the equipment. Be familiar with the controls and the proper usage of the equipment. Save these instructions.



Important Medical Information

Read the medical alert card provided with the gun. It contains injection injury treatment information for a doctor. Keep it with you when operating the equipment.

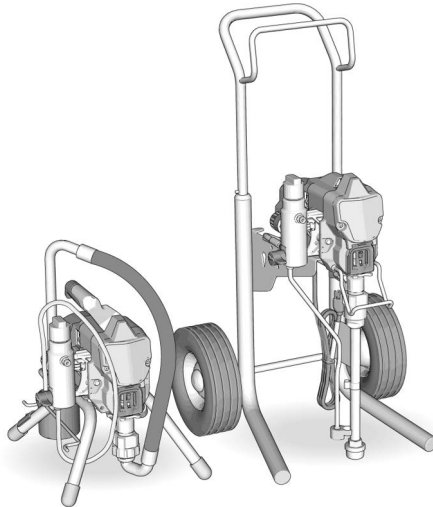

t102964a

PROVEN QUALITY. LEADING TECHNOLOGY.

Contents

Translated Manuals	3
Models	4
Related Manuals	4
Safety Symbols	5
General Warnings	6
Component Identification	10
Stand Models	10
Hi-Cart Models	11
Grounding	12
Extension Cords	12
Pails	12
Pressure Relief Procedure	14
Trigger Lock	15
Setup	16
Startup	20
Operation	22
Spray Tip Installation	22
Aligning Spray	23
Spray	23
Clear Tip Clog	24
Cleanup	25
Maintenance	29
Recycling and Disposal	30
End of Product Life	30
Troubleshooting	31
Mechanical/Fluid Flow	31
Electrical	33
390 Stand Sprayers Parts	35
390 Hi-Cart Sprayers Parts	36
Filter	37
Motor	38
390 Parts List	39
Wiring Diagrams	40
120V	40
240V / 110V UK	41
Technical Specifications	42
California Proposition 65	43
Graco Standard Warranty	44

Translated Manuals

Digital versions of translated manuals for this product can be found online at www.graco.com/390manual, or by scanning the QR code listed under **Link to Languages** below. Available translations and their respective Graco manual numbers are listed here for reference.

Bulgarian	X005493BG	Japanese	X005493JA
Chinese	X005493ZH	Korean	X005493KO
Croatian	X005493HR	Latvian	X005493LV
Czech	X005493CS	Lithuanian	X005493LT
Danish	X005493DA	Norwegian	X005493NO
Dutch	X005493NL	Polish	X005493PL
English	X005493EN	Portuguese	X005493PT
Estonian	X005493ET	Romanian	X005493RO
Finnish	X005493FI	Slovakian	X005493SK
French	X005493FR	Slovenian	X005493SL
German	X005493DE	Spanish	X005493ES
Greek	X005493EL	Swedish	X005493SV
Hungarian	X005493HU	Turkish	X005493TR
Italian	X005493IT		





Link to Languages

To locate translated manuals online, scan the QR code and find the appropriate manual on the web page which appears.



www.graco.com/390manual

Models

	VAC	Model	Stand 	Hi-Cart 
	120 USA	Ultra [®] 390	25F501	25F502
		Ultimate [™] 390	826311	826312
	230 CEE 7/7	Ultra 390	25F509	25F510
	110 UK	Ultra 390	25F511	
	230 Asia/ANZ	Ultra 390	25F517	25F518
	100 Japan/Taiwan	Ultra 390	25F519	









Related Manuals









Find English manuals and any available translations at www.graco.com.

Manual in English	Description
311861	Gun – Contractor/FTx
334599	Pump

Safety Symbols

The following safety symbols appear throughout this manual and on warning labels. Read the table below to understand what each symbol means.

Symbol	Meaning
	Electrical Shock Hazard
	Entanglement Hazard
	Equipment Misuse Hazard
	Fire and Explosion Hazard
	Moving Parts Hazard
	Skin Injection Hazard
	Skin Injection Hazard
	Splash Hazard
	Toxic Fluid and Fumes Hazard

Symbol	Meaning
	Do Not Place Hands or Other Body Parts Near Fluid Outlet
	Do Not Put Hand in Front of Spray Tip
	Do Not Stop Leaks with Hand, Body, Glove or Rag
	Eliminate Ignition Sources
	Follow Pressure Relief Procedure
	Ground Equipment
	Read Manual
	Ventilate Work Area
	Wear Personal Protective Equipment



Safety Alert Symbol

This symbol indicates: Attention! Become Alert! Look for this symbol throughout the manual to indicate important safety messages.

General Warnings

The following warnings apply throughout this manual. Read, understand, and follow the warnings before using this equipment. Failure to follow these warnings can result in serious injury.

WARNING



GROUNDING

This product must be grounded. In the event of an electrical short circuit, grounding reduces the risk of electric shock by providing an escape wire for the electric current. This product is equipped with a cord having a grounding wire with an appropriate grounding plug. The plug must be plugged into an outlet that is properly installed and grounded in accordance with all local codes and regulations.

- Improper Installation of the grounding plug is able to result in a risk of electric shock.
- This product is for use on a nominal 110V, 120V, or 230V circuit and has a grounding plug similar to the plugs illustrated in the figure below.

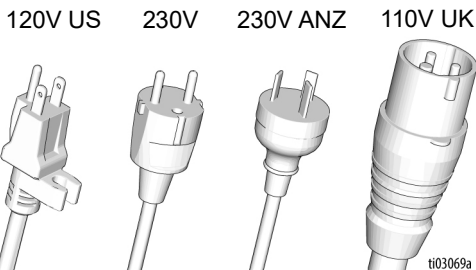

- Only connect the product to an outlet having the same configuration as the plug.
- Do not modify the plug provided; if it does not fit the outlet, have the proper outlet installed by a qualified electrician.
- Do not use a 3-to-2 adapter with this product.
- When repair or replacement of the cord or plug is required, do not connect the grounding wire to either power terminal.
- The wire with insulation having an outer surface that is green with or without yellow stripes is the grounding wire.
- Check with a qualified electrician or serviceman when the grounding instructions are not completely understood, or when in doubt as to whether the product is properly grounded.

Extension Cords:

- Use only a 3-wire extension cord that has a grounding plug and a grounding receptacle that accepts the plug on the product.
- Make sure your extension cord is not damaged.
- If an extension cord is necessary, use a 12 AWG (2.5mm²) minimum to carry the current that the product draws. An undersized cord results in a drop in line voltage and loss of power and overheating.

WARNING



FIRE AND EXPLOSION HAZARD

Flammable fumes, such as solvent and paint fumes, in work area can ignite or explode. To help prevent fire and explosion:



- Do not spray flammable or combustible materials near an open flame or sources of ignition such as cigarettes, motors, and electrical equipment.
- Paint or solvent flowing through the equipment is able to result in static electricity. Static electricity creates a risk of fire or explosion in the presence of paint or solvent fumes. All parts of the spray system, including the pump, hose assembly, spray gun, and objects in and around the spray area shall be properly grounded to protect against static discharge and sparks. Use Graco conductive or grounded high-pressure airless paint sprayer hoses.
- Verify that all containers and collection systems are grounded to prevent static discharge. Do not use pail liners unless they are antistatic or conductive.
- Connect to a grounded outlet and use grounded extensions cords. Do not use a 3-to-2 adapter.
- Do not use a paint or a solvent containing halogenated hydrocarbons.
- Do not spray flammable or combustible liquids in a confined area.
- Keep spray area well-ventilated. Keep a good supply of fresh air moving through the area.
- Sprayer generates sparks. Keep pump assembly in a well ventilated area at least 20 feet (6.1 m) from the spray area when spraying, flushing, cleaning, or servicing. Do not spray pump assembly.
- Do not smoke in the spray area or spray where sparks or flame is present.
- Do not operate light switches, engines, or similar spark producing products in the spray area.
- Do not plug or unplug power cords when flammable fumes are present.
- **Stop operation immediately** if static sparking occurs or you feel shock. Do not use equipment until you identify and correct the problem.
- Keep area clean and free of paint or solvent containers, rags, and other flammable materials.
- Know the contents of the paints and solvents being sprayed. Read all Safety Data Sheets (SDS) and container labels provided with the paints and solvents. Follow the paint and solvents manufacturer's safety instructions.
- Keep a working fire extinguisher in the work area.



ELECTRIC SHOCK HAZARD

This equipment must be grounded. Improper grounding, setup, or usage of the system can cause electric shock.



- Turn off and disconnect power cord before servicing equipment.
- Connect only to grounded electrical outlets.
- Use only 3-wire extension cords.
- Ensure ground prongs are intact on power and extension cords.
- Do not expose to rain. Store indoors.
- Only use an authorized service center to replace a damaged power cord.

General Warnings

WARNING



SKIN INJECTION HAZARD

High-pressure spray is able to inject toxins into the body and cause serious bodily injury. In the event that injection occurs, **get immediate surgical treatment.**



- Do not aim the gun at, or spray any person or animal.
- Keep hands and other body parts away from the discharge. For example, do not try to stop leaks with any part of the body.
- Always use the spray tip guard. Do not spray without spray tip guard in place.
- Use Graco spray tips.
- Use caution when cleaning and changing spray tips. In the case where the spray tip clogs while spraying, follow the **Pressure Relief Procedure**, page 14, for turning off the unit and relieving the pressure before removing the spray tip to clean.
- Equipment maintains pressure after power is shut off. Do not leave the equipment energized or under pressure while unattended. Follow the **Pressure Relief Procedure**, page 14, when the equipment is unattended or not in use, and before servicing, cleaning, or removing parts.
- Check hoses and parts for signs of damage. Replace any damaged hoses or parts.
- This system is capable of producing 3300 psi (228 bar, 22.8 MPa). Use Graco replacement parts or accessories that are rated a minimum of 3300 psi (228 bar, 22.8 MPa).
- Always engage the trigger lock when not spraying. Verify the trigger lock is functioning properly.
- Verify that all connections are secure before operating the unit.
- Know how to stop the unit and bleed pressure quickly. Be thoroughly familiar with the controls.



EQUIPMENT MISUSE HAZARD

Misuse can cause death or serious injury.

- Always wear appropriate gloves, eye protection, and a respirator or mask when painting.
- Do not operate or spray near children. Keep children away from equipment at all times.
- Do not overreach or stand on an unstable support. Keep effective footing and balance at all times.
- Stay alert and watch what you are doing.
- Do not operate the unit when fatigued or under the influence of drugs or alcohol.
- Do not kink or over-bend the hose.
- Do not expose the hose to temperatures or to pressures in excess of those specified by Graco.
- Do not use the hose as a strength member to pull or lift the equipment.
- Do not spray with a hose shorter than 25 feet (7.6 m).
- Do not alter or modify equipment. Alterations or modifications may void agency approvals and create safety hazards.
- Make sure all equipment is rated and approved for the environment in which you are using it.



PRESSURIZED ALUMINUM PARTS HAZARD

Use of fluids that are incompatible with aluminum in pressurized equipment can cause serious chemical reaction and equipment rupture. Failure to follow this warning can result in death, serious injury, or property damage.

- Do not use 1,1,1-trichloroethane, methylene chloride, other halogenated hydrocarbon solvents or fluids containing such solvents.
- Do not use chlorine bleach.
- Many other fluids may contain chemicals that can react with aluminum. Contact your material supplier for compatibility.

WARNING



MOVING PARTS HAZARD

Moving parts can pinch, cut, or amputate fingers and other body parts.

- Keep clear of moving parts.
- Do not operate equipment with protective guards or covers removed.
- Equipment can start without warning. Before checking, moving, or servicing equipment, follow the **Pressure Relief Procedure**, and disconnect all power sources.



TOXIC FLUID OR FUMES HAZARD

Toxic fluids or fumes can cause serious injury or death if splashed in the eyes or on skin, inhaled, or swallowed.

- Read Safety Data Sheets (SDSs) to know the specific hazards of the fluids ou are using.
- Store hazardous fluid in approved containers, and dispose of it according to applicable guidelines.



PERSONAL PROTECTIVE EQUIPMENT

Wear appropriate protective equipment when in the work area to help prevent serious injury, including eye injury, hearing loss, inhalation of toxic fumes, and burns. This protective equipment includes but is not limited to:

- Protective eyewear, and hearing protection.
- Respirators, protective clothing, and gloves as recommended by the fluid and solvent manufacturer.

Component Identification

Component Identification

Stand Models

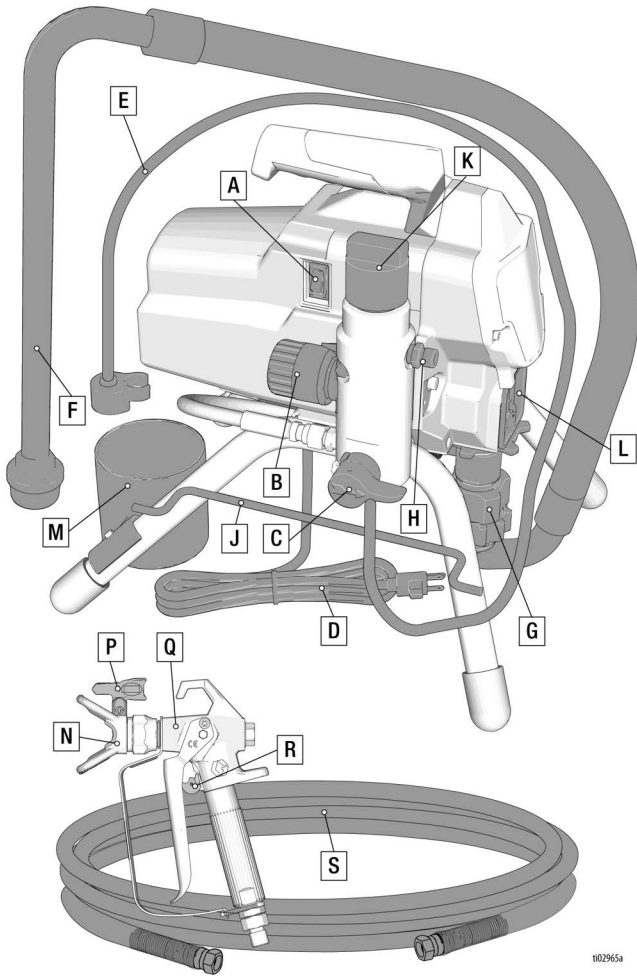

102965a

A	ON/OFF Switch
B	Pressure Control
C	Prime Valve
D	Power Cord
E	Drain Tube
F	Fluid Intake
G	Pump
H	Fluid Outlet
J	Power Cord Wrap

K	Sprayer Filter Access
L	Finger Guard / TSL Fill Point
M	Drip Cup
N	Tip Guard
P	Spray Tip
Q	Gun
R	Trigger Lock
S	Airless Hose
	Model/Serial Tag (Not shown, located on bottom of unit.)

Component Identification

Hi-Cart Models

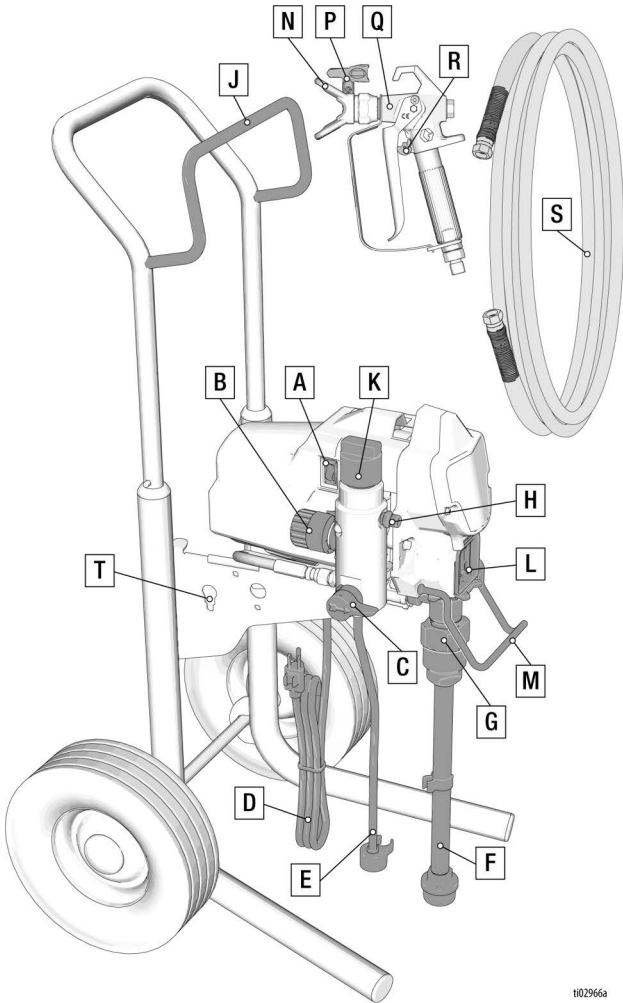

t102966a

A	ON/OFF Switch
B	Pressure Control
C	Prime Valve
D	Power Cord
E	Drain Tube
F	Fluid Intake
G	Pump
H	Fluid Outlet
J	Hose Hanger
K	Sprayer Filter Access

L	Finger Guard / TSL Fill Point
M	Pail Hook
N	Tip Guard
P	Spray Tip
Q	Gun
R	Trigger Lock
S	Airless Hose
T	Rod Adjustment Tool
	Model/Serial Tag (Not shown, located on bottom of unit.)

Grounding



The equipment must be grounded to reduce the risk of static sparking and electric shock. An electric or static spark can cause fumes to ignite or explode. An improper ground can cause electric shock. A good ground provides an escape wire for the electric current.

This sprayer is equipped with a Power Cord that has a ground wire and an appropriate grounding plug.

The plug must be plugged into an outlet that is properly installed and grounded in accordance with all local codes and ordinances.

Do not modify the plug provided; if it does not fit the outlet, have the proper outlet installed by a qualified electrician.

Extension Cords

Use an extension cord with an undamaged ground contact. If an extension cord is necessary, use a 3-wire, 12 AWG (2.5 mm²) minimum.

NOTE: Smaller gauge or longer extension cords may reduce sprayer performance.

Pails

Solvent and oil-based fluids: follow local code. Use only conductive metal pails, placed on a grounded surface such as concrete.

Do not place pail on a non-conductive surface such as paper or cardboard which interrupts grounding continuity.

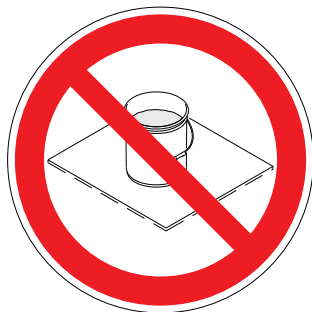

Always ground a metal pail: connect a ground wire to the pail. Clamp one end to the pail and the other end to a true earth ground such as a metal water pipe.

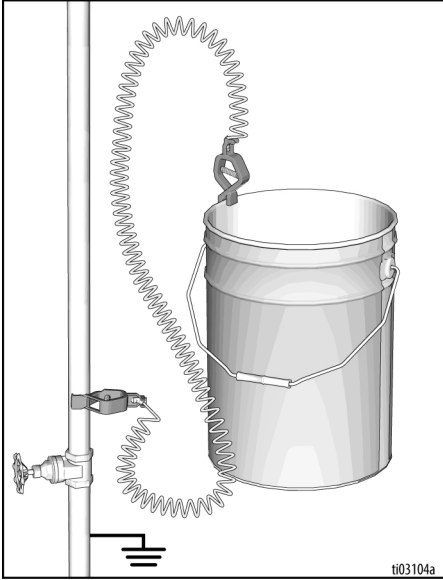

To maintain ground continuity when sprayer is flushed or pressure is relieved: hold metal part of spray Gun firmly to the side of a grounded metal pail then trigger the Gun.

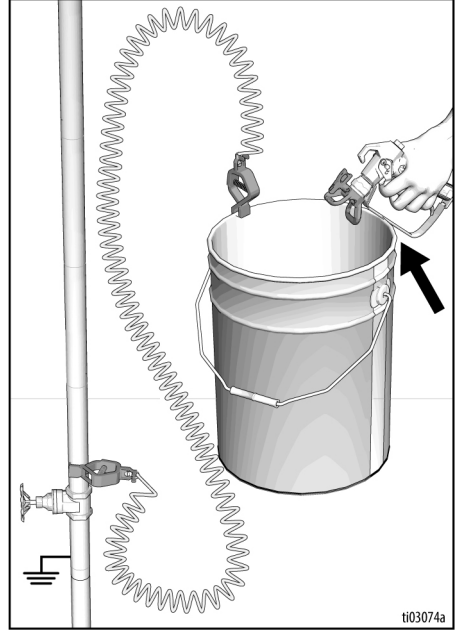

Pressure Relief Procedure

Pressure Relief Procedure



Follow the Pressure Relief Procedure whenever you see this symbol.

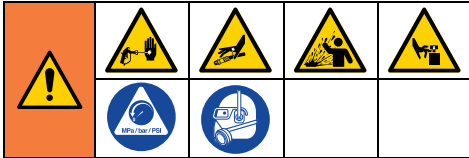

This equipment stays pressurized until pressure is manually relieved. To help prevent serious injury from pressurized fluid, such as skin injection, splashed fluid and moving parts, follow the Pressure Relief Procedure whenever sprayer is stopped and before sprayer is cleaned or checked, and before equipment is serviced.

1. Engage the Trigger Lock.

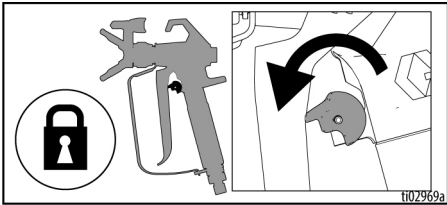

2. Turn the ON/OFF Switch to the **OFF** position. Wait 60 seconds for power to dissipate.

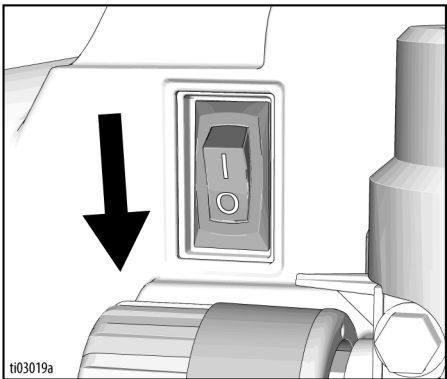

3. Turn Pressure Control to lowest setting.

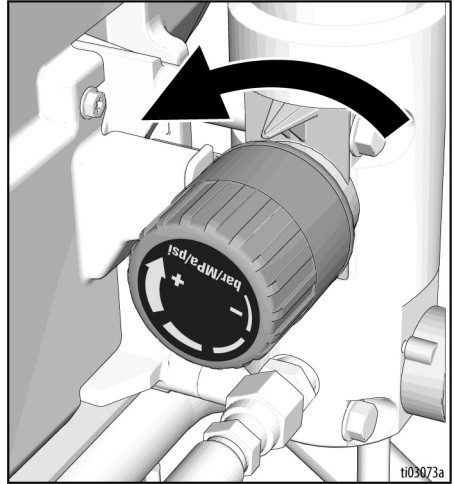

4. Put Drain Tube in a pail. Turn Prime Valve down to the prime position. Leave Prime Valve in down (prime) position until you are ready to spray again.

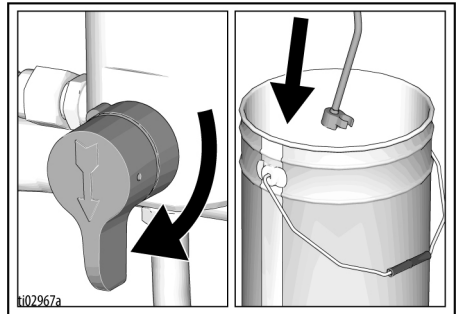

Pressure Relief Procedure

5. Hold a metal part of the Gun firmly to a grounded metal pail. Disengage Trigger Lock and trigger the Gun to relieve pressure.

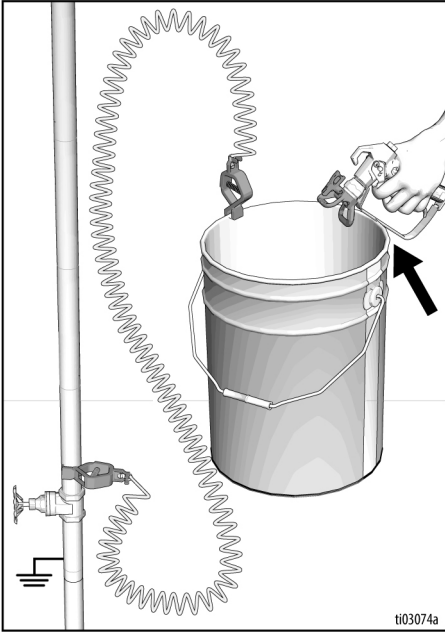

6. Engage the Trigger Lock.
7. If you suspect the Spray Tip or hose is clogged or that pressure has not been fully relieved:
 - a. Using a wrench, **VERY SLOWLY** loosen the tip guard retaining nut or the hose end coupling to relieve pressure gradually.
 - b. Using a wrench, loosen the nut or coupling completely.
 - c. Clear hose or tip obstruction.

Trigger Lock

<p>To prevent injury when the gun is not in use, always engage the gun's Trigger Lock if sprayer is being shut down or left unattended.</p>				

Always engage the Trigger Lock when sprayer is stopped to prevent the Gun from being triggered accidentally by hand or if dropped or bumped.

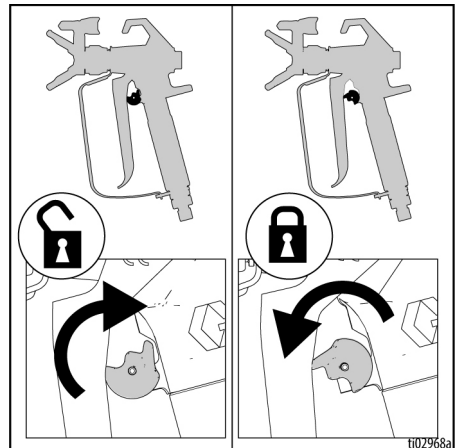

Setup

Setup

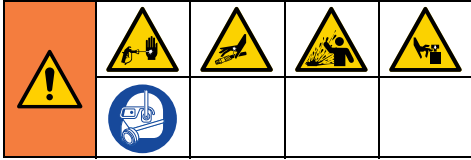

When unpacking sprayer for the first time or after long term storage, perform setup procedure. When first setup is performed, remove shipping plug from Fluid Outlet. Sprayer is equipped with Pump Armor™ in the system.

1. Connect Graco Airless Hose to Fluid Outlet. Use two wrenches to tighten securely.

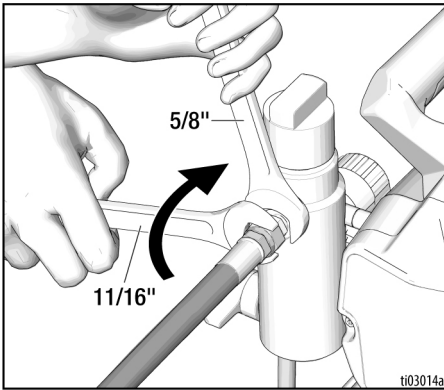

2. Connect other end of hose to Gun.

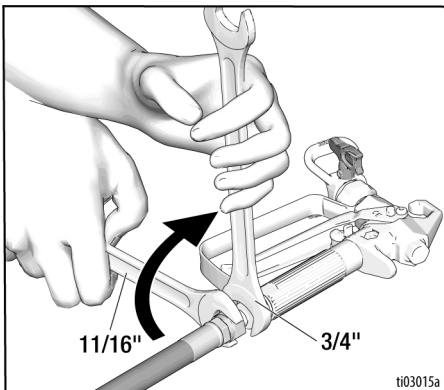

3. Use two wrenches to tighten securely.
4. Engage Trigger Lock.

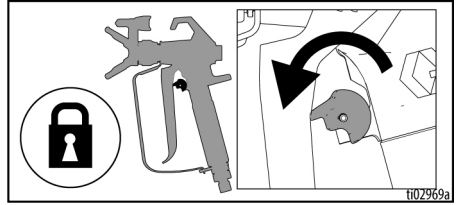

5. Remove Tip Guard.

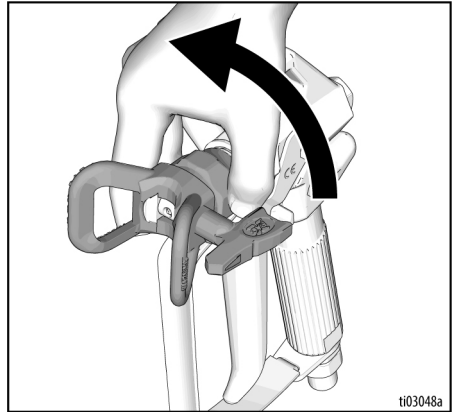

6. After long term storage check inlet strainer for clogs and debris.

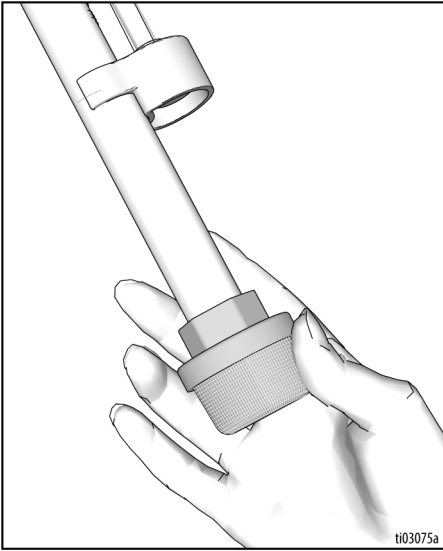

7. Fill throat packing nut with Throat Seal Liquid™ (TSL) to prevent premature packing wear. Do this daily or each time you spray.

- Place the TSL bottle nozzle into the top center opening in the grill at the front of the sprayer.
- Squeeze bottle to dispense enough TSL to fill the space between the pump rod and packing nut seal.

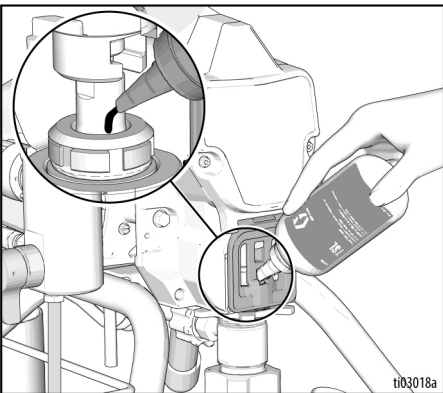

8. Make certain ON/OFF Switch is **OFF**, and Pressure Control is in the lowest setting.

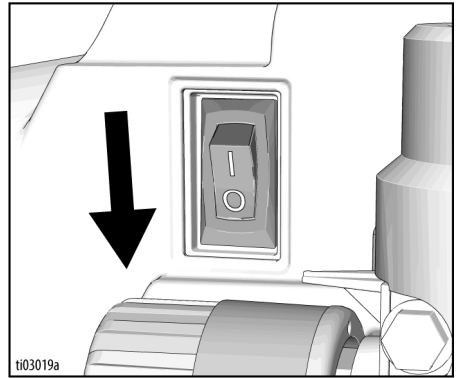

9. Plug power supply cord into a properly grounded electrical outlet.

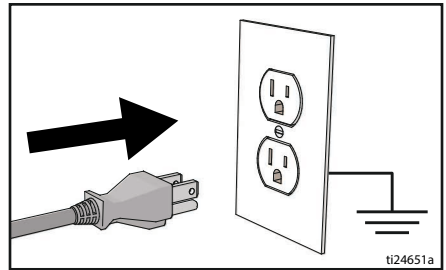

10. Turn Prime Valve down to the prime position.

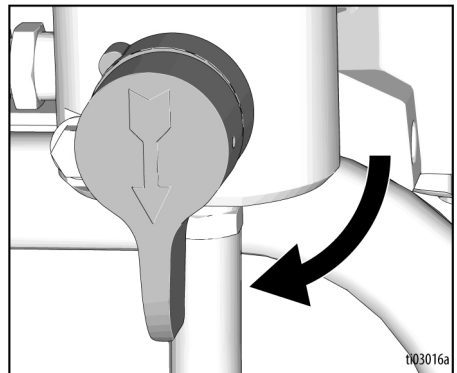

Setup

11. Place Fluid Intake with Drain Tube in grounded metal pail partially filled with flushing fluid. See **Grounding**, page 12.

NOTE: Check flushing fluid for compatibility with material that is to be sprayed. A secondary flush with a compatible fluid may be necessary. Water for latex paint or compatible fluid for oil-based paint.

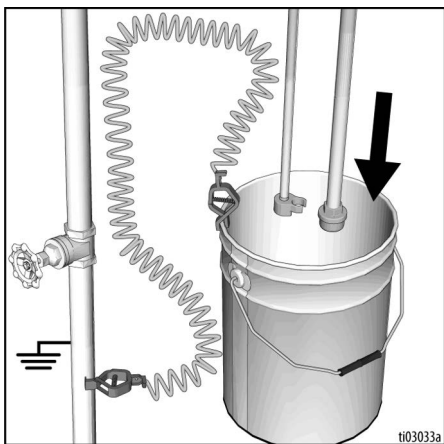

12. Turn Pressure Control to lowest setting.

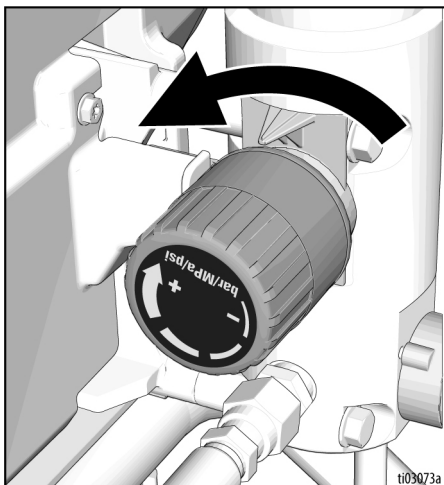

15. Hold a metal part of the Gun firmly to a grounded metal pail. Disengage Trigger Lock and trigger Gun.

13. Turn ON/OFF Switch to **ON** position.

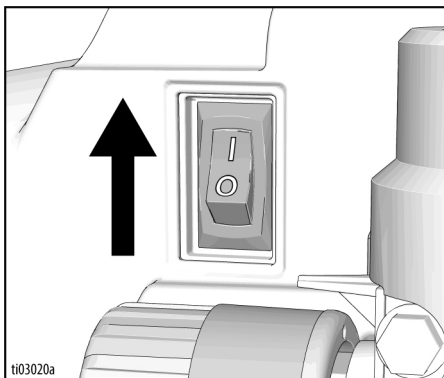

14. Increase pressure 1/2 turn to start motor. Allow fluid to flush through prime hose for one minute.

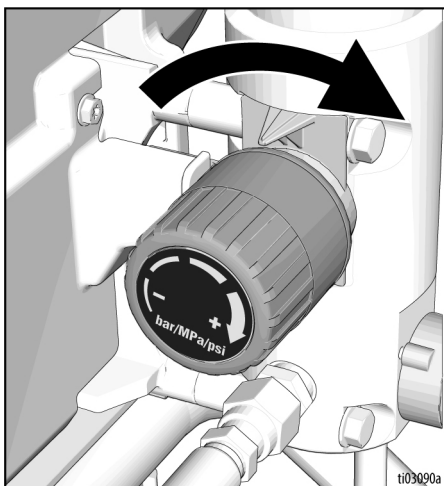

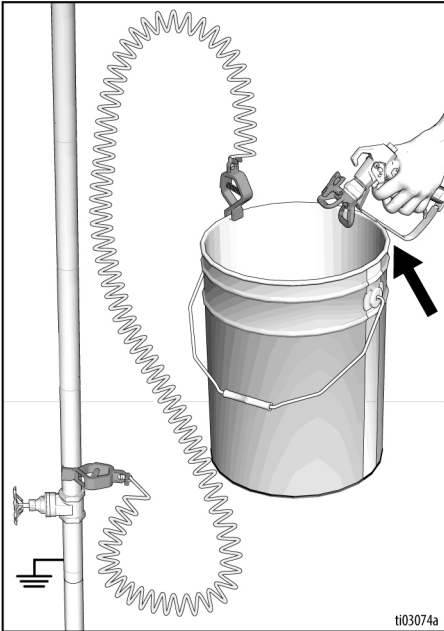

16. While holding gun trigger, turn Prime Valve horizontal to the spray position. Flush until clean.

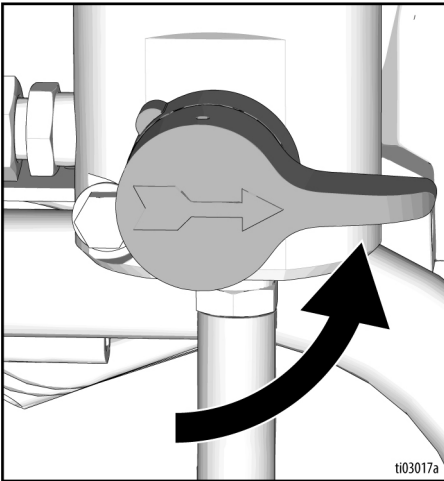

17. Release gun trigger and engage Trigger Lock.

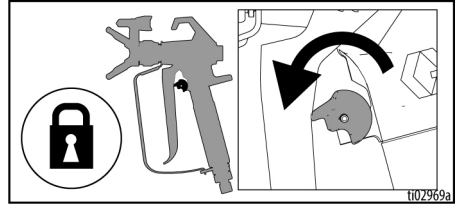

18. Turn ON/OFF Switch to **OFF** position.

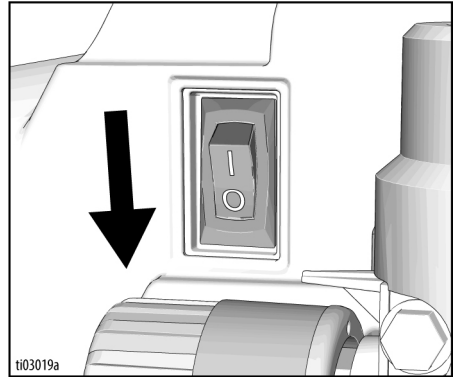

19. If the initial flushing fluid is not compatible with the paint that is to be sprayed, a second flush is needed. Repeat steps 11-18.
20. Sprayer is now ready to start up and spray.

Startup

Startup

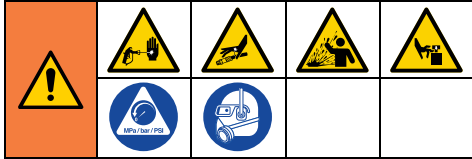

1. Perform **Pressure Relief Procedure**, page 14.
2. Turn Pressure Control to lowest setting.

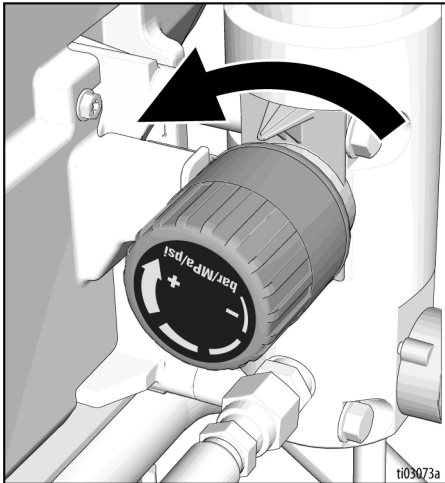

3. Remove Tip Guard.

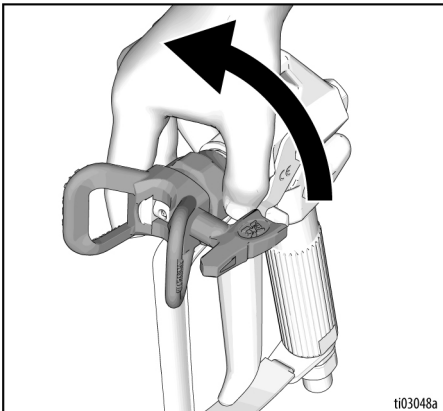

4. Turn ON/OFF Switch to **ON** position.

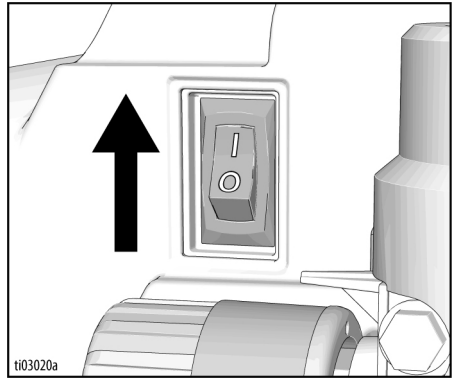

5. Place Fluid Intake in paint pail. Place Drain Tube in waste pail.

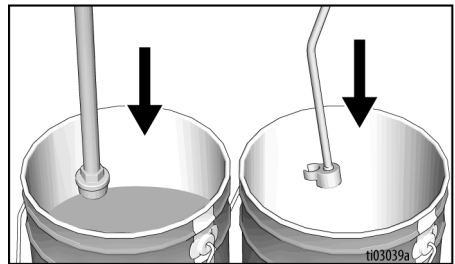

6. Increase pressure 1/2 turn to start motor. Allow paint to circulate through sprayer until paint flows out the Drain Tube.

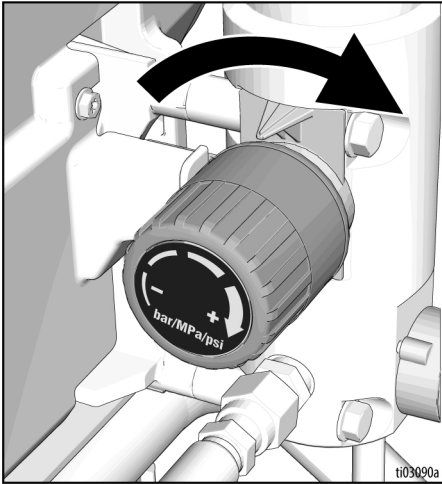

7. Disengage Trigger Lock.

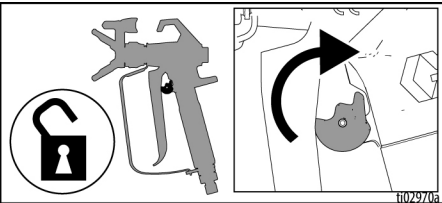

8. Hold Gun against grounded metal waste pail.

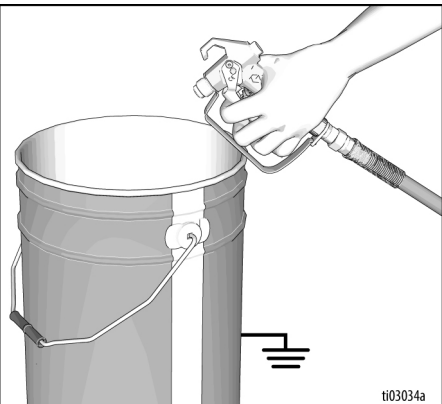

9. While holding gun trigger, turn Prime Valve horizontal to the spray position. Keep Gun triggered at least one minute or 10 seconds after paint appears.

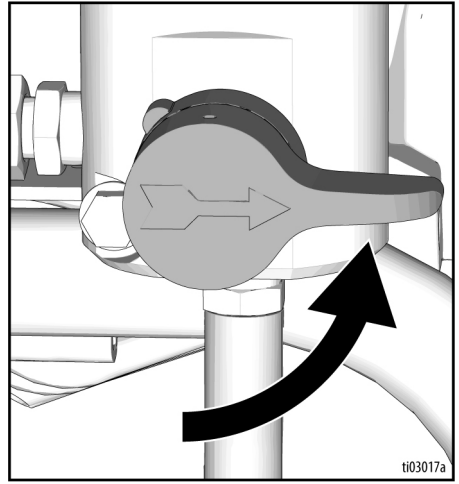

10. Release gun trigger and engage Trigger Lock.



High-pressure spray is able to inject toxins into the body and cause serious bodily injury. Do not stop leaks with hand or rag.

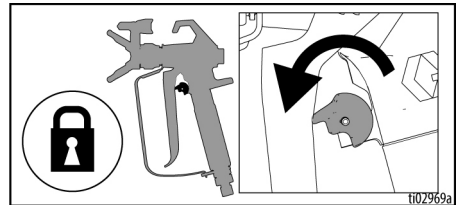

11. Inspect Airless Hose and hose connections for leaks. If leaks occur, perform **Pressure Relief Procedure**, page 14, then tighten all fittings and repeat **Startup** procedure. If there are no leaks, continue with **Operation**, page 22.

Operation

Spray Tip Installation



To avoid serious injury from skin injection, do not put your hand in front of the Spray Tip when installing or removing the Spray Tip and Tip Guard.

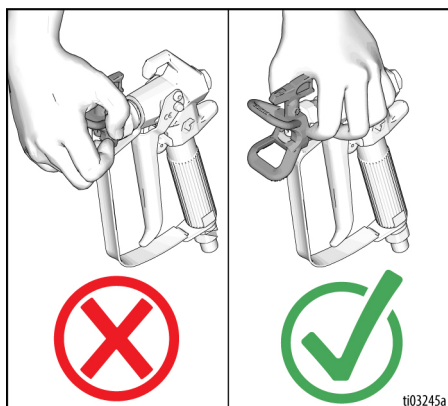

1. Perform **Pressure Relief Procedure**, page 14.
2. Use Spray Tip (A) to insert OneSeal™ (B) and tip seat into Tip Guard (C).

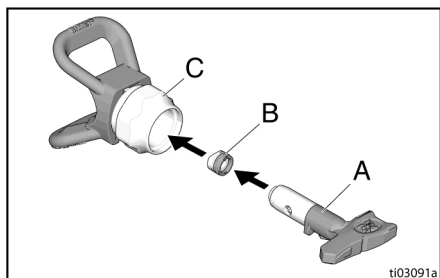

3. Insert Spray Tip.

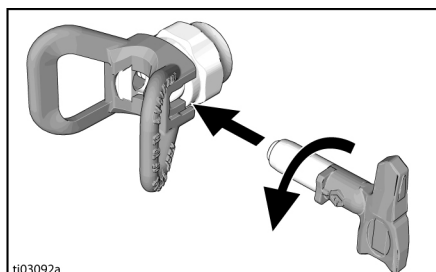

4. Screw assembly onto Gun. Tighten.

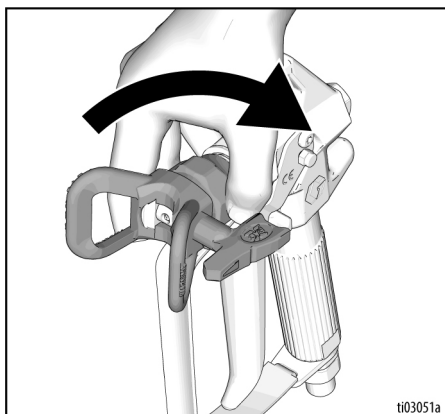

Aligning Spray

1. Relieve pressure. Follow the **Pressure Relief Procedure**, page 14.
2. Engage Trigger Lock.
3. Loosen guard retaining nut.
4. Align guard horizontally to spray a horizontal pattern or vertically to spray a vertical pattern.

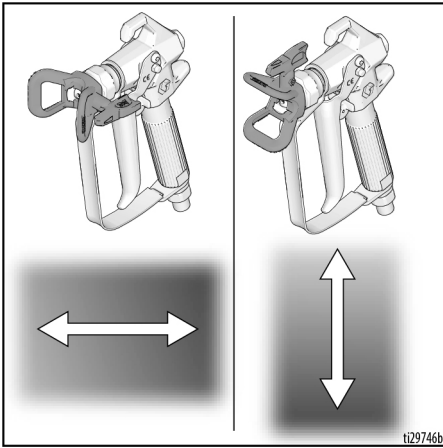

5. Hand tighten guard retaining nut when you have adjusted to desired setting.

Spray

When a RAC X™ LP Low Pressure reversible Spray Tip is used, spraying pressure can be lowered. Spraying at a lower pressure results in less overspray and reduces Spray Tip wear. Adjust the sprayer pressure to minimize overspray.

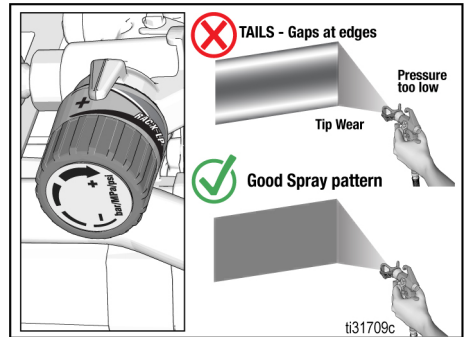

1. Spray test pattern. Increase pressure to eliminate heavy edges.

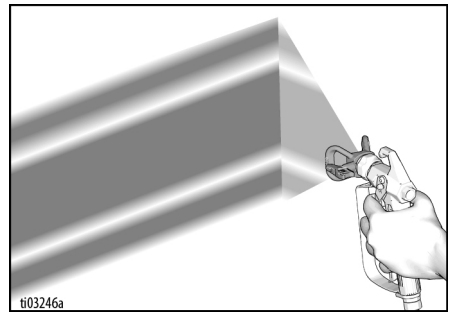

Operation

- Use smaller tip size if pressure adjustment cannot eliminate heavy edges.
- Hold Gun perpendicular, 10-12 in. (25-30 cm) from surface. Spray back and forth; overlap by 50%.

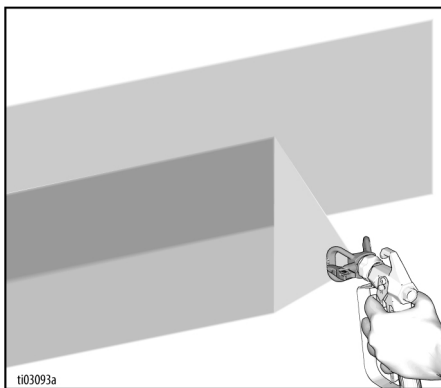

- Trigger Gun after moving. Release trigger before stopping. For additional spraying information, see separate Gun manual.

Clear Tip Clog



- Release trigger. Engage Trigger Lock. Rotate Spray Tip to unclog position. Disengage Trigger Lock. Trigger Gun at waste area to clear clog.

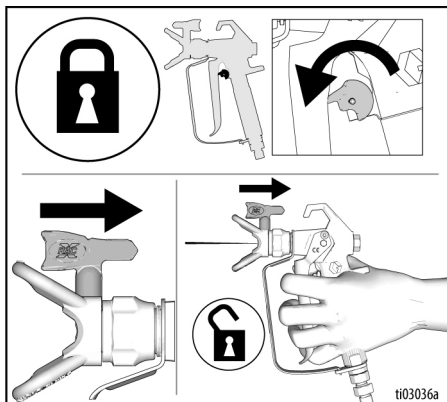

- Engage Trigger Lock. Return Spray Tip to spray position. Disengage Trigger Lock and continue spraying.

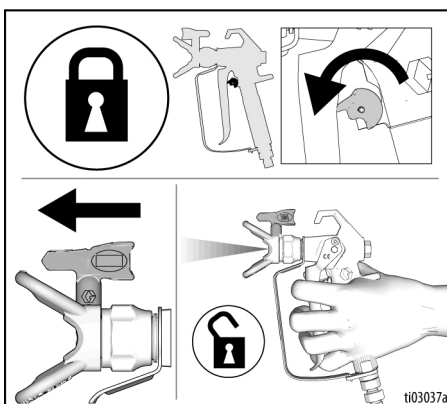

NOTE: If Spray Tip is still clogged, repeat steps 1 and 2. If still plugged, you may have to replace the Spray Tip.

Cleanup

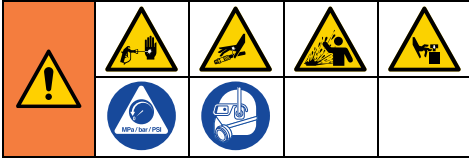

1. Perform **Pressure Relief Procedure**, page 14.
2. Remove Tip Guard and Spray Tip. For additional information, see separate Gun manual.

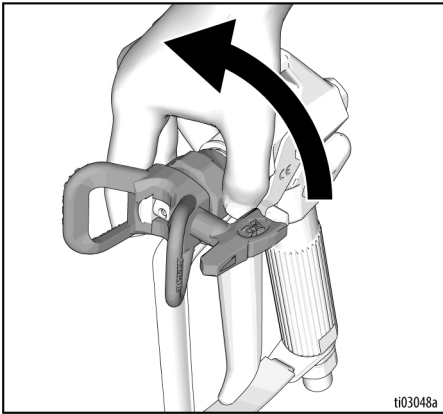

ti03048a

3. Remove Fluid Intake and Drain Tube from paint, wipe excess paint off outside.

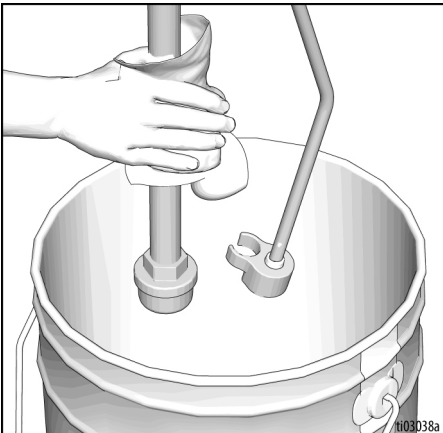

ti03038a

4. Place Fluid Intake in flushing fluid. Use water for water-based paint and compatible fluid for oil-based paint. Place Drain Tube in waste pail.

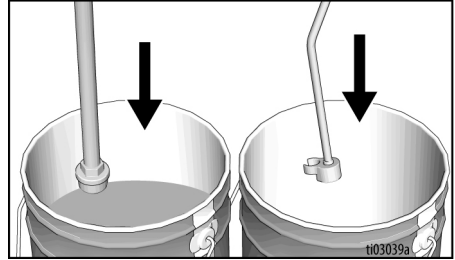

ti03039a

5. Turn Prime Valve down to the prime position.

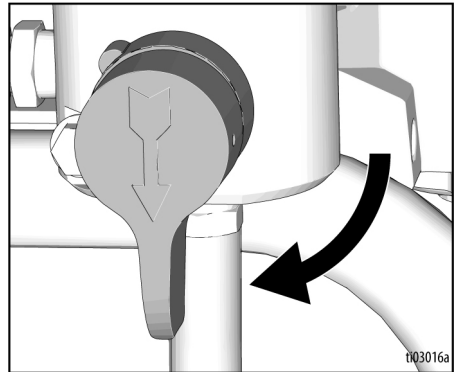

ti03016a

6. Turn Pressure Control 1/2 turn to start motor. Run until flushing fluid appears clear in waste pail.

Operation

7. Disengage Trigger Lock. Hold Gun against grounded metal pail. Trigger Gun continuously.

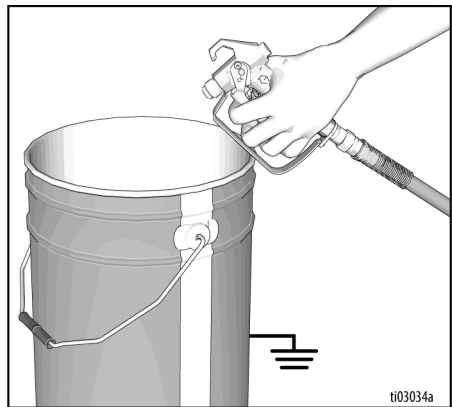
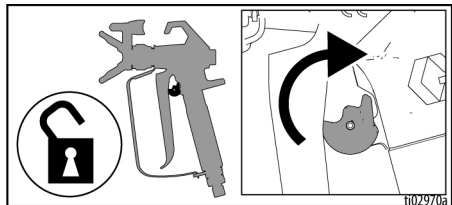

8. While holding gun trigger, turn Prime Valve to spray position. Continue to hold gun trigger for one minute or until flushing fluid appears clear in waste pail.



9. While triggering Gun, raise suction tube above flushing fluid to purge fluid from hose. Continue to hold trigger until fluid stops flowing.

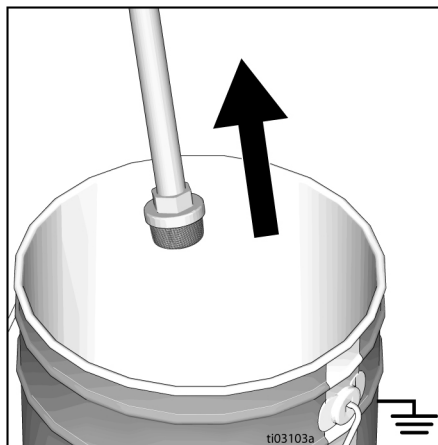

10. Engage Trigger Lock.

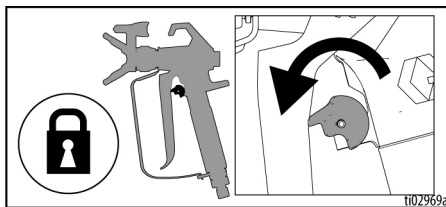

11. Turn Pressure Control knob to the lowest pressure setting and turn ON/OFF Switch to **OFF** position. Disconnect power to sprayer. Turn Prime Valve down to the prime position.

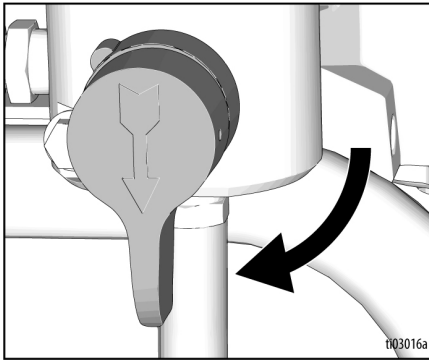
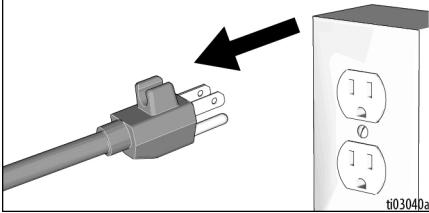
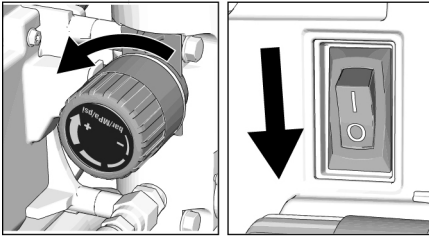

12. If flushing with water, flush again with compatible fluid or Graco Pump Armor™ to leave a protective coating to prevent freezing and corrosion.

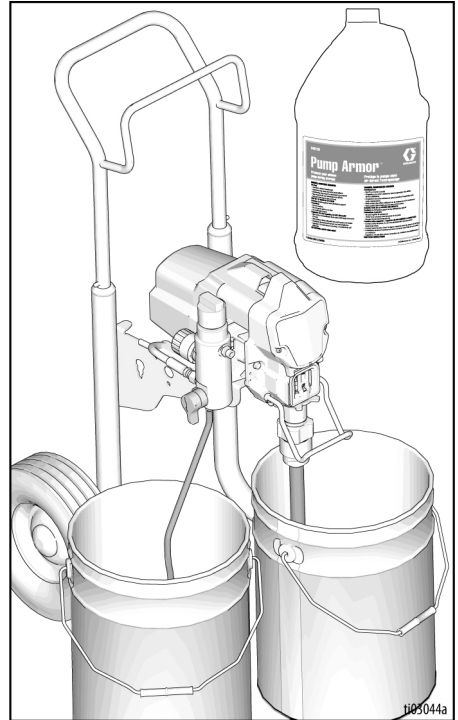

Operation

13. Perform **Pressure Relief Procedure**, page 14.
14. Remove filter from Gun and sprayer if installed. Clean and inspect. Install new filter if damage is present. See separate Gun manual.

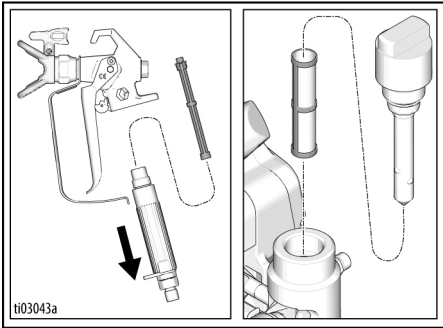

15. Wipe sprayer, hose and Gun with a rag soaked in water or compatible fluid.

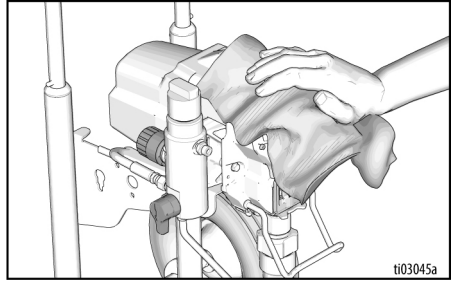

Maintenance

Routine maintenance is important to ensure proper operation of your sprayer. Maintenance includes performing routine actions which keep your sprayer in operation and prevents trouble in the future.



Activity	Interval
Inspect/clean sprayer filter, fluid inlet strainer, and Gun filter.	Daily or each time you spray
Inspect motor shield vents for blockage.	Daily or each time you spray
Fill TSL by adding through TSL fill point.	Daily or each time you spray
<p>Check sprayer stall.</p> <p>With sprayer Gun NOT triggered, sprayer motor should stall and not restart until Gun is triggered again.</p> <p>If sprayer starts again with Gun NOT triggered, inspect Pump for internal/external leaks and check Prime Valve for leaks.</p>	Every 1000 gallons (3785 liters)
<p>Throat packing adjustment</p> <p>When pump packing begins to leak after extended use, tighten packing nut down until leakage stops or lessens. This allows approximately 100 gallons of additional operation before a repacking is required. Packing nut can be tightened without O-ring removal.</p>	As necessary based on usage

Recycling and Disposal

End of Product Life

At the end of the product's useful life, dismantle and recycle it in a responsible manner.

- Perform the **Pressure Relief Procedure**, page 14.
- Drain and dispose of fluids according to applicable regulations. Refer to the material manufacturer's Safety Data Sheet.

- Remove motors, batteries, circuit boards, LCDs (liquid crystal displays), and other electronic components. Recycle according to applicable regulations.

- Do not dispose of electronic components with household or

commercial waste. 

- Deliver remaining product to a recycling facility.

Troubleshooting

Mechanical/Fluid Flow

1. Follow **Pressure Relief Procedure**, page 14, before checking or repairing.
2. Check all possible problems and causes before disassembling the unit.

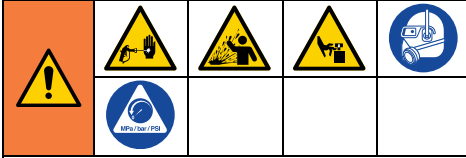

To help prevent serious injury from pressurized fluid, such as skin injection, splashing fluid, and moving parts, follow the **Pressure Relief Procedure** when you stop spraying and before cleaning, checking, or servicing the equipment.

Keep clear of moving parts during troubleshooting procedures.

Problem	What to Check If check is OK, go to next check	What to Do When check is not OK, refer to this column
Pump output is low or poor spray pattern.	Spray Tip worn.	Replace Spray Tip. See separate Gun or tip manual.
	Spray Tip clogged.	Relieve pressure. Check and clean Spray Tip. See Clear Tip Clog , page 24.
	Intake strainer clogged.	Remove and clean, then reinstall.
	Intake valve ball and piston ball are not seating properly.	Remove intake valve and clean. Check balls and seats for nicks; replace if necessary. See Pump manual. Strain paint before using to remove particles that could clog Pump.
	Fluid filter or tip filter is clogged or dirty.	Clean filter.
	Prime Valve leaking.	Repair Prime Valve.
	Verify Pump does not continue to stroke when Gun trigger is released. (Prime Valve not leaking.)	Service Pump. See Pump manual.
	Leaking around throat packing nut which may indicate worn or damaged packings.	Replace packings. See Pump manual. Also check piston valve seat for hardened paint or nicks and replace if necessary. Tighten packing nut/wet-cup.

Troubleshooting

Problem	What to Check If check is OK, go to next check	What to Do When check is not OK, refer to this column
Pump output is low.	Large pressure drop in hose with heavy materials.	Reduce overall length of hose.
	Pump rod damage.	Repair Pump. See Pump manual.
	Low stall pressure.	Turn pressure knob fully clockwise. Make sure Pressure Control knob is properly installed to allow full clockwise position. If problem persists, replace Pressure Control.
	Piston packings are worn or damaged.	Replace packings. See Pump manual.
	Check extension cord for correct size.	See Extension Cords , page 12.
Excessive paint leakage into throat packing nut.	Throat packing nut is loose.	Remove throat packing nut spacer. Tighten throat packing nut just enough to stop leakage.
	Throat packings are worn or damaged.	Replace packings. See Pump manual.
	Displacement rod is worn or damaged.	Replace rod. See Pump manual.
Fluid is spitting from Gun.	Air in Pump or hose.	Check and tighten all fluid connections. Cycle Pump as slowly as possible during priming.
	Spray Tip is partially clogged.	Clear tip. See Clear Tip Clog , page 24.
	Fluid supply is low or empty.	Refill fluid supply. Prime Pump. See Pump manual. Check fluid supply often to prevent running Pump dry.
Pump is difficult to prime.	Air in Pump or hose.	Check and tighten all fluid connections. Cycle Pump as slowly as possible during priming.
	Intake valve is leaking.	Clean intake valve. Be sure ball seat is not nicked or worn and that ball seats well. Reassemble valve.
	Pump packings are worn.	Replace pump packings. See Pump manual.
	Paint is too thick.	Thin the paint according to supplier recommendations.

Electrical

Symptom: Sprayer does not run, stops running, or will not shut off.

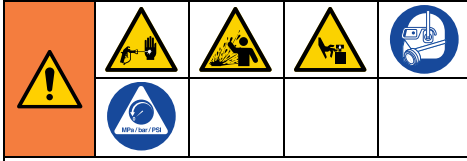

To help prevent serious injury from pressurized fluid, such as skin injection, splashing fluid, and moving parts, follow the **Pressure Relief Procedure** when you stop spraying and before cleaning, checking, or servicing the equipment.

Keep clear of moving parts during troubleshooting procedures.

1. Perform **Pressure Relief Procedure**, page 14.
2. Plug sprayer into correct voltage, grounded outlet.
3. Turn the ON/OFF Switch to **OFF**, wait 30 seconds and then turn power back **ON** again (this ensures sprayer is in normal run mode).
4. Turn Pressure Control knob clockwise 1/2 turn.



To avoid electrical shock when covers are removed for troubleshooting, wait 1 minute after disconnecting Power Cord for stored electricity to dissipate.

Problem	What to Check	How to check
Sprayer does not run at all.	Check electrical supply.	Make certain that there is AC voltage. 100-130V for 110-120VAC models or 210-255V for 230VAC models.
	Check Pressure Control connections.	Make certain connector is clean and firmly connected.
	Check Pressure Control.	Connect known good Pressure Control. If the motor runs, replace Pressure Control.
	Check motor leads.	Make certain terminals are clean and firmly connected.
Sprayer will not shut off after reaching or exceeding maximum pressure.	Check Pressure Control.	Disconnect Pressure Control, if sprayer still runs, replace control board. If the sprayer stops, replace Pressure Control.
Sprayer has an error.	Check Error Code Messages , page 34.	See Error Code Messages , page 34.

Troubleshooting

Symptom: Sprayer does not run, stops running, or will not shut off.

1. Perform **Pressure Relief Procedure**, page 14.
2. Unplug sprayer and turn the ON/OFF Switch to **OFF**.
3. Wait 1 minute. Remove rear shroud to see LED status light. Plug power supply cord into a properly grounded electrical outlet. Turn ON/OFF Switch back **ON** (this ensures sprayer is in normal run mode).

4. Error code will blink on LED status light.

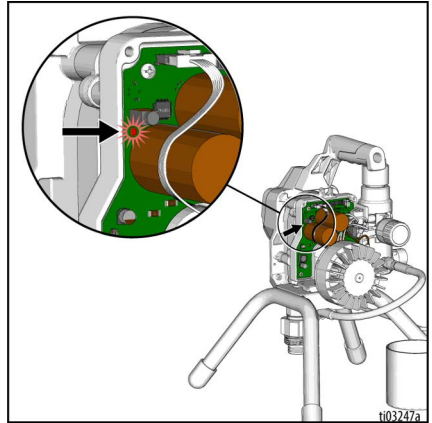





<p>To avoid serious injury from electrical shock and moving parts, do not touch motor or electrical components.</p>				

Error Code Messages

CODE	MESSAGE	ACTION
04	Code 04-Multiple incoming voltage surges detected	Turn sprayer OFF and unplug the sprayer. Locate good voltage supply to prevent damage to electronics.
05	Code 05-Motor not spinning due to high mechanical load	Turn sprayer OFF and unplug the sprayer. Attempt to spin. Motor should spin freely. If motor doesn't spin easily, remove Pump and re-check by spinning motor again. If motor spins easily, check control board.
06	Code 06-Motor thermal protection enabled	Keep sprayer plugged in and allow time to cool. This may take up to an hour. Check vents in bottom and top of sprayer for blockage. Unplug sprayer and check to make sure the motor spins freely.
08	Code 08-Incoming voltage too low for sprayer operation	Turn sprayer OFF and unplug the sprayer. Locate good voltage supply to prevent damage to electronics.
09	Code 09-Communication to encoder failed	Turn sprayer OFF and unplug the sprayer and wait five minutes. Remove shroud. Check cables and connections. Check motor.
10	Code 10-Control board thermal protection enabled	Keep sprayer plugged in and allow time to cool. This may take up to an hour. Check vents in bottom and top of sprayer for blockage. Unplug sprayer and check to make sure the motor spins freely.
12	Code 12-Excessive current protection enabled	Cycle power ON and OFF . If problem persists, check motor.
15	Code 15-Motor not spinning, no motor current detected	Turn sprayer OFF and unplug the sprayer and wait five minutes. Remove shroud. Check cables and connections. Check control board. Check motor.

390 Stand Sprayers Parts

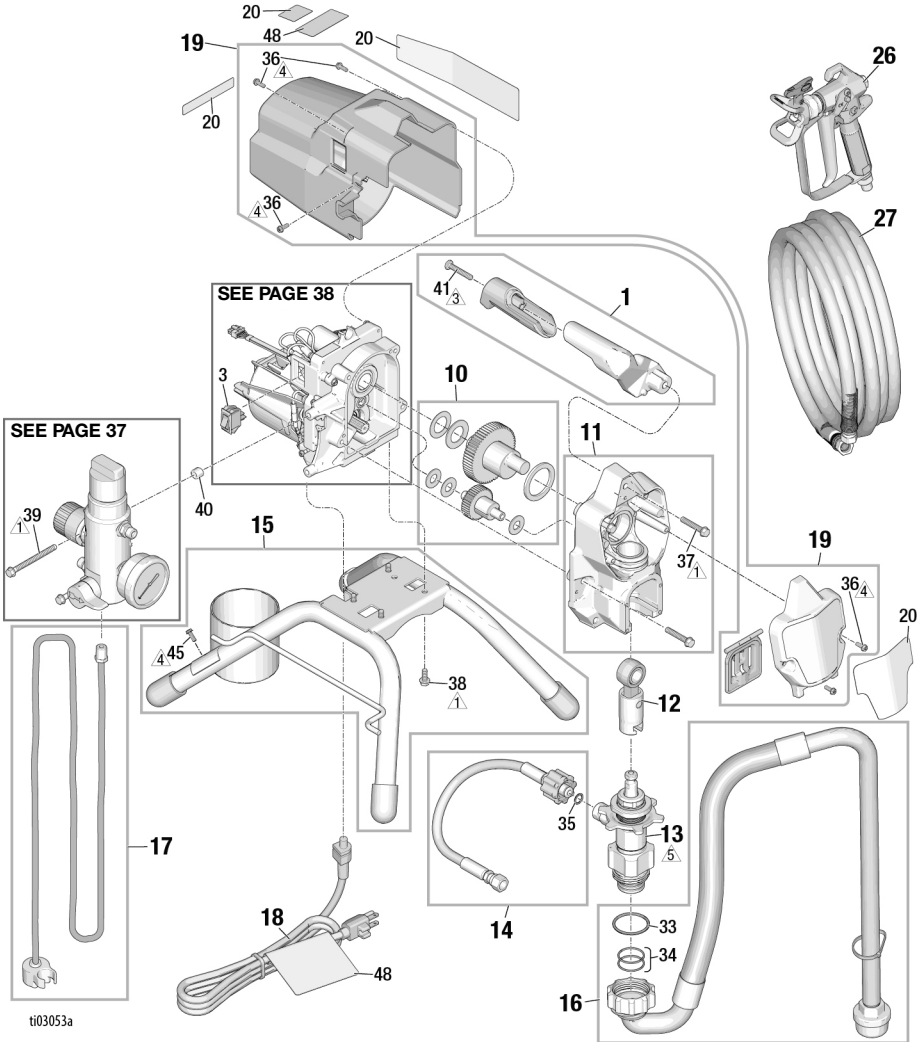

Ref.	Torque
	140-160 in-lb (15.8 - 18.1 N•m)
	40-45 in-lb (4.5 - 5.1 N•m)

Ref.	Torque
	23-27 in-lb (2.6 - 3.1 N•m)
	65-75 ft-lb (88 - 102 N•m)



390 Hi-Cart Sprayers Parts

390 Hi-Cart Sprayers Parts

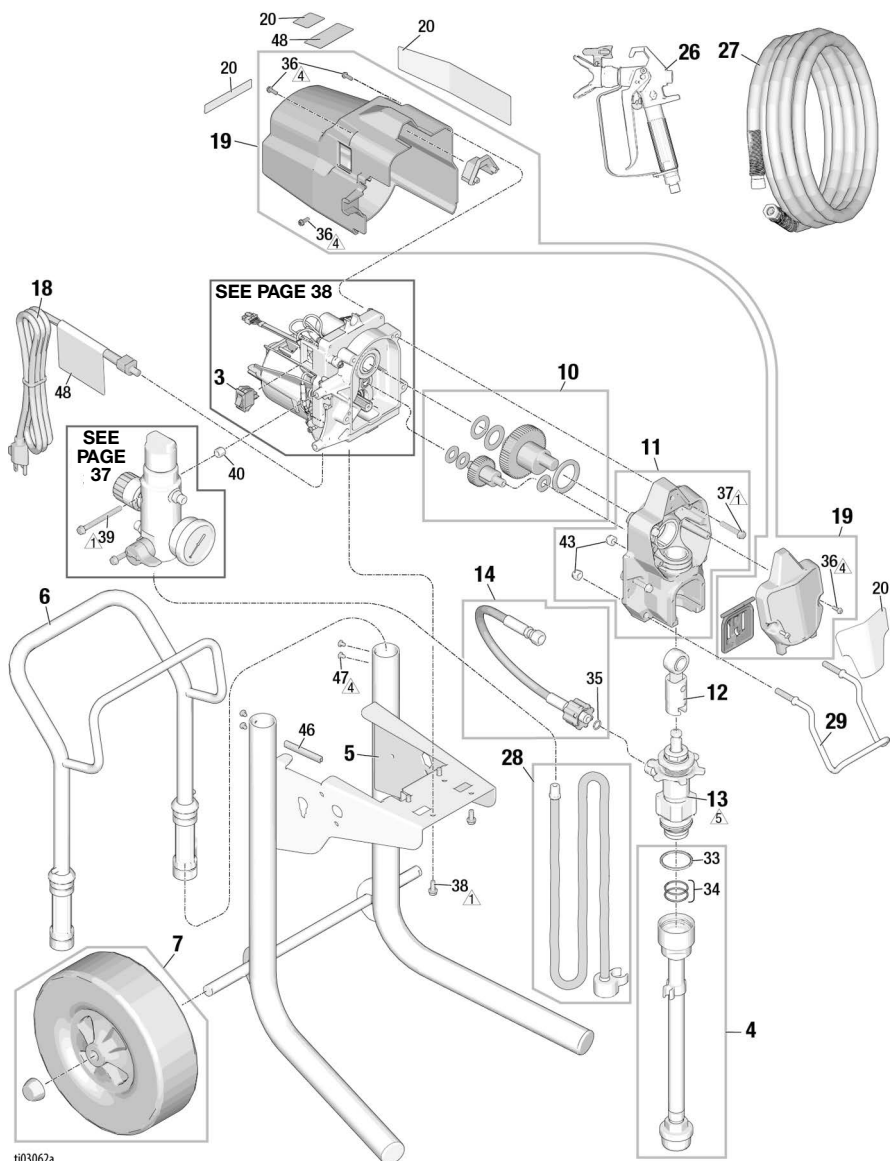

Ref.	Torque
	140-160 in-lb (15.8 - 18.1 N•m)
	23-27 in-lb (2.6 - 3.1 N•m)

Ref.	Torque
	65-75 ft-lb (88 - 102 N•m)



t103062a

Filter

Ref.	Torque
 1	140-160 in-lb (15.8 - 18.1 N•m)
 2	130-150 in-lb (14.7 - 16.9 N•m)

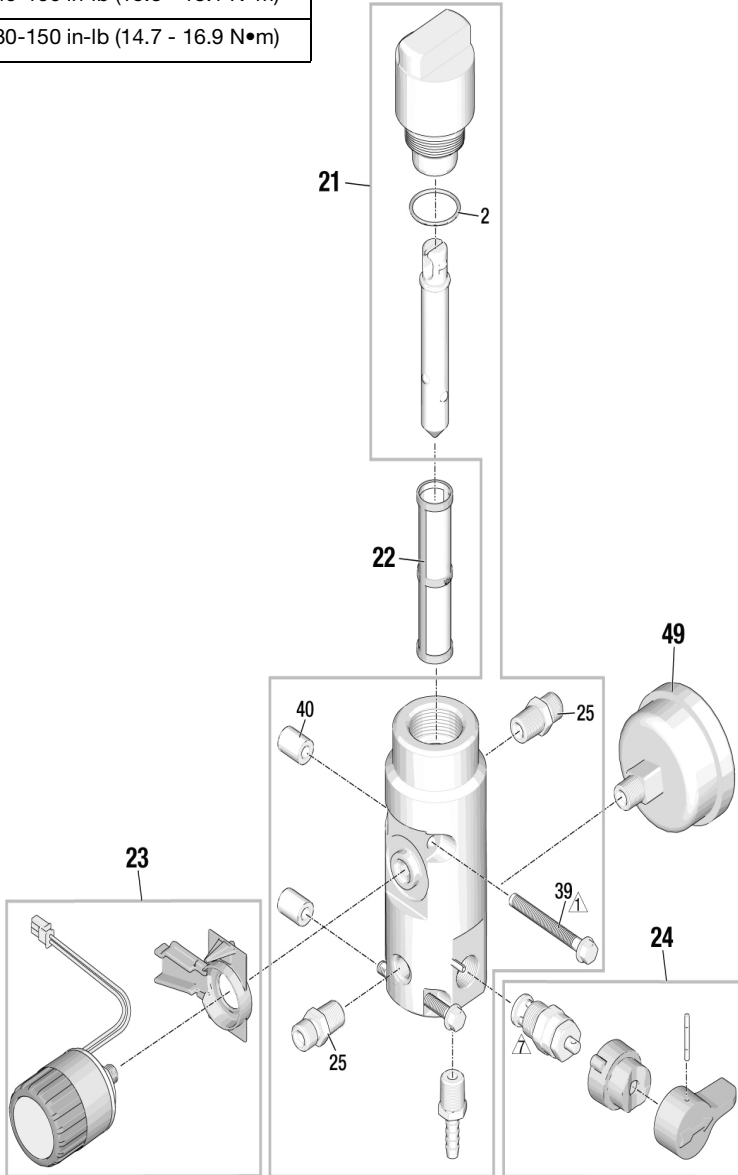

t03063a

Motor

Motor

Ref.	Torque
	30-35 in-lb (3.4 - 4.0 N•m)

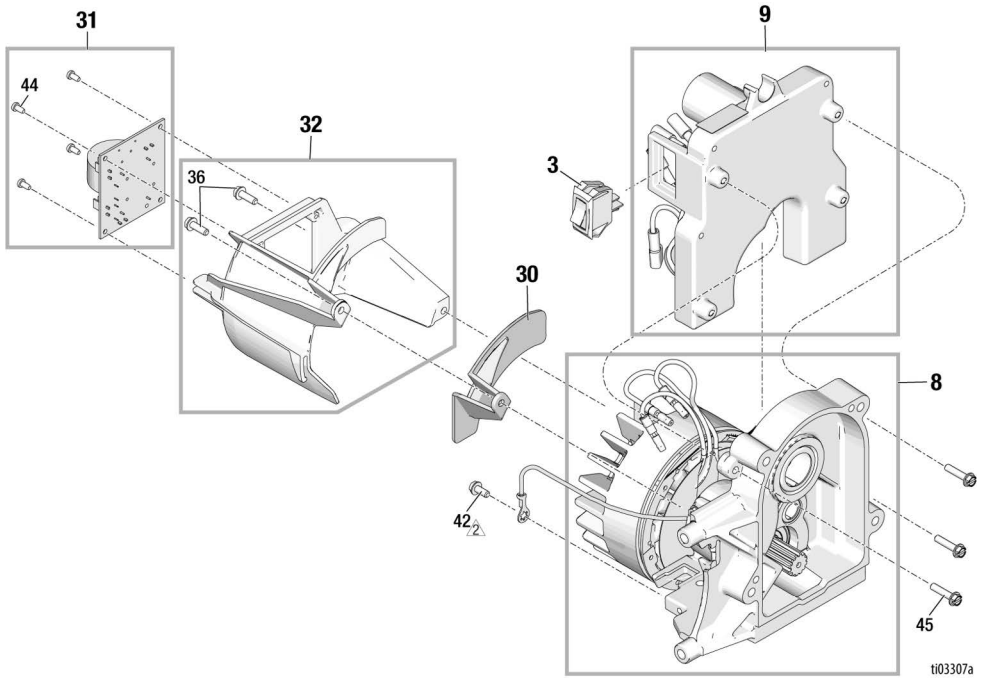

ti03307a

390 Parts List

Ref.	Order Part No.	Description
1	2008850	Handle Kit
2	117828	PTFE Encapsulated O-Ring
3	116255	Power Switch Replacement
4	2008854	Hi-Cart Suction Hose Kit
5	2007765	Hi-Cart Frame
6	287489	Hi-Cart Handle
7	2008852	Wheel and Hub Kit (1 Wheel)
8	2008224	120V Brushless Motor Kit
	2008225	240V Brushless Motor Kit
9	2007952	120V Control Assembly, 390
	2007955	240V Control Assembly, 390
10	2008839	Gears Kit
11	24W817	Drive Housing Kit
12	24W640	Connecting Rod Kit
13	19D873	Pump Kit Domestic
	20B348	Pump Kit EMEA
	20B349	Pump Kit AP
14	24W830	Pump Hose Kit
15	2008838	Stand Frame Kit
16	20B438	Suction Hose Kit
17	2008863	Drain Line Kit (Stand)
18	2008845	Power Cord Kit, US
	2008846	Power Cord Kit, Japan/TW
	2008847	Power Cord Kit, EMEA
	2008848	Power Cord Kit, ANZ/Korea
	2008849	Power Cord Kit, UK
19	2008851	390 Shroud Kit
20	2008861	Branding, Labels Kit, Ultra
	2008862	Branding, Labels Kit, Ultimate
21	2008841	390 Filter Manifold Kit
	2008842	390 Filter Manifold Kit with Gauge
22	246384	60 Mesh Manifold Filter Kit
	246425	30 Mesh Manifold Filter Kit
	246382	100 Mesh Manifold Filter Kit
23	2008843	Pressure Control Kit
24	235014	Drain Valve Kit
25	162453	1/4" NPT x 1/4" NPSM Fitting
26		FTX Gun Kit with LP517
27		1/4" x 50' Paint Hose

Ref.	Order Part No.	Description
28	2008864	Hi-Cart Drain Line Kit
29	2001457	Pail Hanger
30	2008858	Wire Guard Kit (Domestic 390 only)
31	2008856	120V Filter Board Kit (if applicable)
	2008857	240V Filter Board Kit (if applicable)
32	2008855	Filter Board Shroud Kit (if applicable)
33	117117	Pump O-Ring
34	16N901	Pump O-Ring
35	16H137	Pump Hose O-Ring
36	2001659	#8-32 x 0.5" Hex Wsh Hd Thd Form Screw
37	117493	1/4-20 x 1.5" Hex Wsh Hd Thd Form Screw
38	112774	1/4-20 x 0.625" Hex Wsh Hd Thd Form Screw
39	2008500	1/4-20 x 3" Hex Wsh Hd Thd Form Screw
40	17D294	Manifold Spacers
41	19D260	1/4-20 x 1.5" Pan Hd Thd Form Screw
42	115498	#8-32 x 0.375" Hex Wsh Hd Thd Form Screw
43	111040	5/16-18 Lock Nut
44	115522	#4-20 x 0.25" Plastic Thd Form Screw
45	127914	#8-32 x 0.75" Hex Hd Thd Form Screw
46	20B541	Edge Guard
47	109032	#10-32 x 0.25" Pan Hd Thd Form Screw
48▲	19D674	Warning Label, US/NA
	16D675	Warning Label, ANZ/Korea
	19D677	Warning Label, Japan/TW
	16G596	Warning Label, EMEA/UK
49	115523	Pressure Gauge
▲	222385	Medical Alert Card, US, CE, and UK models (not shown)
	17A134	Medical Alert Card, ANZ/KOR models (not shown)
	26A998	Medical Alert Card, Japan/Taiwan models (not shown)

▲ Replacement safety labels, tags, and cards are available at no cost.

Wiring Diagrams

Wiring Diagrams

120V

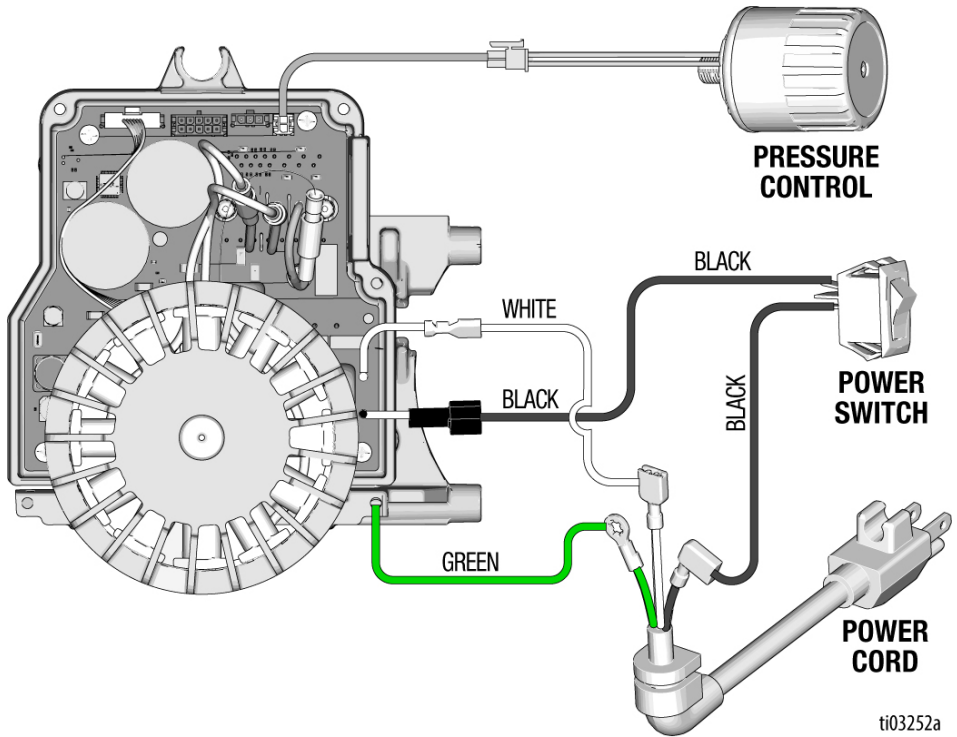

ti03252a

240V / 110V UK

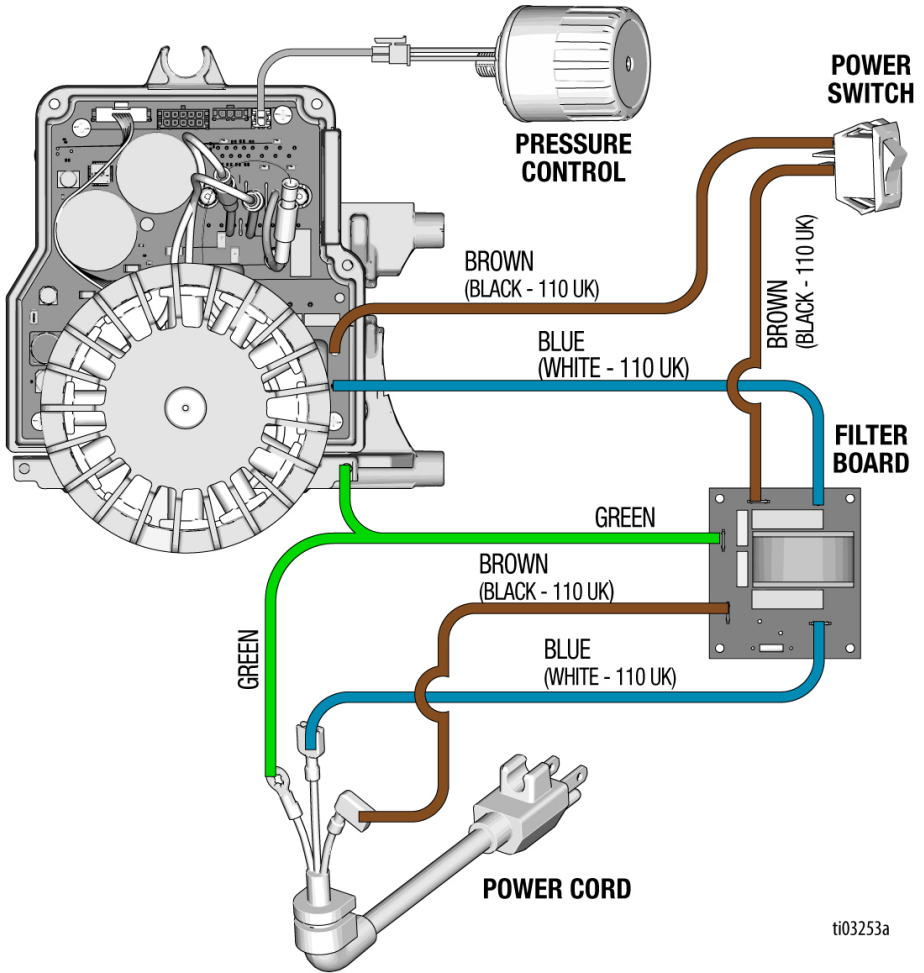

ti03253a

Technical Specifications

Technical Specifications

390 Models		
	US	Metric
Maximum fluid working pressure		
390 Models	3300 psi	228 bar, 22.8 MPa
Maximum Delivery		
390 Models	0.47 gpm	1.8 lpm
Maximum Tip Size		
390 Models	0.021	0.021
Fluid Outlet		
	1/4 in. npsm	1/4 in. npsm
Cycles		
	700 per gallon	185 per liter
Generator Minimum		
	3000 W	3000 W
100–120V, A, Hz		
	1Ø, 13, 50/60	
220–240V, A, Hz		
	1Ø, 9, 50/60	
Dimensions		
Height		
Stand	17.5 in.	44.5 cm
Hi-Cart	30 in. (Handle down) 40 in. (Handle up)	76.2 cm (Handle down) 101.6 cm (Handle up)
Length		
Stand	16 in.	40.6 cm
Hi-Cart	22 in.	55.9 cm
Width		
Stand	13.5 in.	34.3 cm
Hi-Cart	20.5 in.	52.1 cm
Weight		
Stand	27 lb.	12.25 kg
Hi-Cart	61 lb.	27.7 kg
Noise** (dBa) @ 70 psi (0.48 MPa, 4.8 bar)		
Sound pressure	90 dBa	
Sound power	100 dBa	
Materials of Construction		
Wetted materials on all models	zinc- and nickel-plated carbon steel, nylon, stainless steel, PTFE, Acetal, leather, UHMWPE, aluminum, tungsten carbide, polyethylene, fluoroelastomer, urethane	
Notes		
**Sound pressure measured 3 feet (1 meter) from equipment. Sound power measured per ISO-3744.		

California Proposition 65

CALIFORNIA RESIDENTS

 **WARNING:** Cancer and reproductive harm –
www.P65warnings.ca.gov.

Graco Information

For the latest information about Graco products, visit www.graco.com.

For patent information, see www.graco.com/patents.

TO PLACE AN ORDER, contact your Graco distributor or call 1-800-690-2894 to identify the nearest distributor.

Graco Standard Warranty

Graco warrants all equipment referenced in this document which is manufactured by Graco and bearing its name to be free from defects in material and workmanship on the date of sale to the original purchaser for use. With the exception of any special, extended, or limited warranty published by Graco, Graco will, for a period of twelve months from the date of sale, repair or replace any part of the equipment determined by Graco to be defective. This warranty applies only when the equipment is installed, operated and maintained in accordance with Graco's written recommendations.

This warranty does not cover, and Graco shall not be liable for general wear and tear, or any malfunction, damage or wear caused by faulty installation, misapplication, abrasion, corrosion, inadequate or improper maintenance, negligence, accident, tampering, or substitution of non-Graco component parts. Nor shall Graco be liable for malfunction, damage or wear caused by the incompatibility of Graco equipment with structures, accessories, equipment or materials not supplied by Graco, or the improper design, manufacture, installation, operation or maintenance of structures, accessories, equipment or materials not supplied by Graco.

This warranty is conditioned upon the prepaid return of the equipment claimed to be defective to an authorized Graco distributor for verification of the claimed defect. If the claimed defect is verified, Graco will repair or replace free of charge any defective parts. The equipment will be returned to the original purchaser transportation prepaid. If inspection of the equipment does not disclose any defect in material or workmanship, repairs will be made at a reasonable charge, which charges may include the costs of parts, labor, and transportation.

THIS WARRANTY IS EXCLUSIVE, AND IS IN LIEU OF ANY OTHER WARRANTIES, EXPRESS OR IMPLIED, INCLUDING BUT NOT LIMITED TO WARRANTY OF MERCHANTABILITY OR WARRANTY OF FITNESS FOR A PARTICULAR PURPOSE.

Graco's sole obligation and buyer's sole remedy for any breach of warranty shall be as set forth above. The buyer agrees that no other remedy (including, but not limited to, incidental or consequential damages for lost profits, lost sales, injury to person or property, or any other incidental or consequential loss) shall be available. Any action for breach of warranty must be brought within two (2) years of the date of sale.

GRACO MAKES NO WARRANTY, AND DISCLAIMS ALL IMPLIED WARRANTIES OF MERCHANTABILITY AND FITNESS FOR A PARTICULAR PURPOSE, IN CONNECTION WITH ACCESSORIES, EQUIPMENT, MATERIALS OR COMPONENTS SOLD BUT NOT MANUFACTURED BY GRACO. These items sold, but not manufactured by Graco (such as electric motors, switches, hose, etc.), are subject to the warranty, if any, of their manufacturer. Graco will provide purchaser with reasonable assistance in making any claim for breach of these warranties.

In no event will Graco be liable for indirect, incidental, special or consequential damages resulting from Graco supplying equipment hereunder, or the furnishing, performance, or use of any products or other goods sold hereto, whether due to a breach of contract, breach of warranty, the negligence of Graco, or otherwise.

FOR GRACO CANADA CUSTOMERS

The Parties acknowledge that they have required that the present document, as well as all documents, notices and legal proceedings entered into, given or instituted pursuant hereto or relating directly or indirectly hereto, be drawn up in English. Les parties reconnaissent avoir convenu que la rédaction du présent document sera en Anglais, ainsi que tous documents, avis et procédures judiciaires exécutés, donnés ou intentés, à la suite de ou en rapport, directement ou indirectement, avec les procédures concernées.

All written and visual data contained in this document reflects the latest product information available at the time of publication. Graco reserves the right to make changes at any time without notice.

Original instructions. This manual contains English. MM X005493EN

Graco Headquarters: Minneapolis
International Offices: Belgium, China, Japan, Korea

GRACO INC. AND SUBSIDIARIES • P.O. BOX 1441 • MINNEAPOLIS MN 55440-1441 • USA

Copyright 2024, Graco Inc. All Graco manufacturing locations are registered to ISO 9001.

www.graco.com

Revision C, January 2025