

GENUINE GRACO PARTS AND ACCESSORIES



255061 Air Valve Repair Kit, SST

For Husky™ 1040, 1590, and 2150 pumps with stainless steel center sections



Important Safety Instructions

Read all warnings and instructions in your pump manual. Save those instructions.

406648A

Ref. No.	Description	Qty.
1	BLOCK, valve	1
2	BLOCK, pilot	1
3	PACKING, o-ring	1
4	PACKING, u-cup	2
5	PACKING, o-ring	2
6	GASKET, cover	1
7	PLATE, valve	1

Figs. 1 through 4 are in the order of reassembly, using the parts in this kit.

- △1 Reuse old screws when possible. Torque to 38-43 in-lb (4.3-4.9 N•m).
- △2 Insert narrow end of push pin (N) first.
- △3 Grease.
- △4 Install with lips facing narrow end of piston (P).
- △5 Insert wide end of piston (P) first.

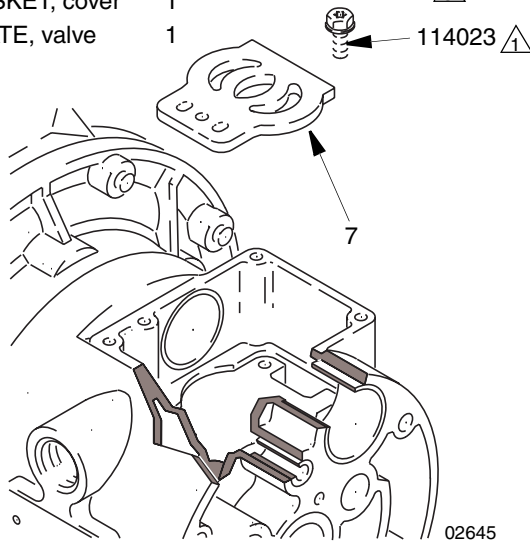

Fig. 1

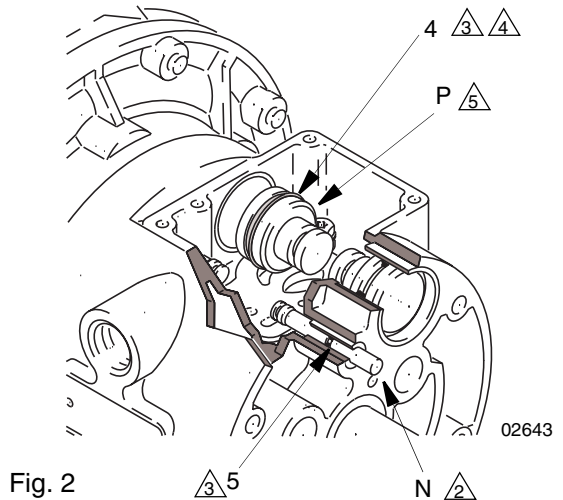

Fig. 2

Graco Inc. P.O. Box 1441 Minneapolis, MN 55440-1441

406648 11/2006

Copyright 2006 Graco Inc. is registered to I.S. EN ISO 9001

- ⚠ 1 Reuse old screws when possible. Torque to 38-43 in-lb (4.3-4.9 N•m).
- ⚠ 3 Grease.
- ⚠ 6 See Detail.
- ⚠ 7 Grease lower face.
- ⚠ 8 Align with grooves in push pins, Snap in place.
- ⚠ 9 Align with grooves in pistons. Push in place

