

# TruMix XT™ Variable Ratio Mixing System

3B0119B

EN

***Electric variable ratio mixing system for the application of two-component coatings. For professional use only. Not approved for use in explosive atmospheres or hazardous (classified) locations.***

**Model: 2003102, 2003103**

600 psi (4.13 MPa, 41.3 bar) Maximum Working Pressure

See page 3 for model information and approvals.



## Important Safety Instructions

Read all warnings and instructions in this manual before using the equipment. Be familiar with the proper control and usage of the equipment. Save these instructions.

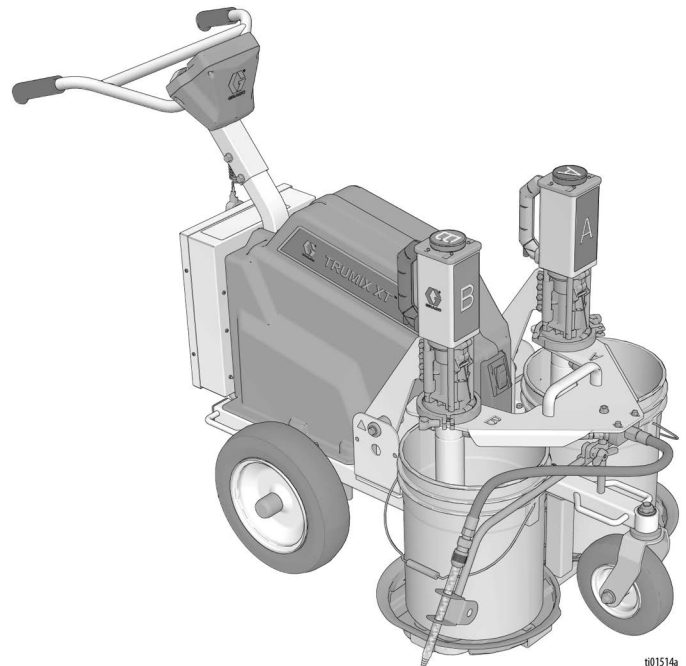

**POWERPSONIC**  
SMART BATTERY  
TRUSTED BATTERY SOLUTIONS

**LITHIUM BLUETOOTH BATTERY SERIES**



App Download

**SERVICE**     **GRACO**



[www.graco.com/techsupport](http://www.graco.com/techsupport)

to every customer, every time

# Contents

<b>Models</b> .....	<b>3</b>	<b>Maintenance</b> .....	<b>35</b>
<b>Important Grounding Information</b> .....	<b>4</b>	Preventative Maintenance Schedule .....	35
<b>Safety Symbols</b> .....	<b>5</b>	<b>Cleaning</b> .....	<b>36</b>
<b>General Warnings</b> .....	<b>6</b>	Dispense Manifold with Check Valves .....	36
<b>Important Information</b> .....	<b>10</b>	Pump Intake Valve .....	37
Overview .....	10	<b>Troubleshooting</b> .....	<b>38</b>
Material Compatibility .....	10	System Does Not Run .....	41
Keep Components A and B Separate .....	10	System Does Not Have Power .....	42
A (Blue) and B (Red) Components .....	10	Battery Will Not Charge .....	43
Changing Materials .....	11	Check Voltage .....	44
Moisture Sensitive Materials .....	11	<b>Display Error Codes</b> .....	<b>45</b>
<b>Component Identification</b> .....	<b>12</b>	<b>System Menu Details</b> .....	<b>47</b>
TruMix XT .....	12	Primary Menu .....	47
Digital Display .....	13	Secondary Menu .....	48
Universal Display Operations .....	14	<b>Parts</b> .....	<b>50</b>
Menu Notes .....	14	TruMix XT .....	50
<b>Pressure Relief Procedure</b> .....	<b>15</b>	TruMix XT Parts List .....	51
<b>Grounding</b> .....	<b>16</b>	Enclosure Component Parts .....	52
Pails .....	16	Enclosure Component Parts List .....	53
<b>Battery and Charger</b> .....	<b>17</b>	Fluid Module Kit Parts .....	54
Check Level .....	17	Fluid Module Kit Parts List .....	55
Battery Disposal .....	17	<b>Wiring Diagram</b> .....	<b>56</b>
Charge the Battery .....	18	<b>Technical Specifications</b> .....	<b>57</b>
<b>Setup</b> .....	<b>19</b>	<b>Recycling and Disposal</b> .....	<b>59</b>
Startup .....	19	Rechargeable Battery Disposal .....	59
Setup Ratios .....	19	End of Product Life .....	59
Mobile Dispense Mode .....	20	<b>Graco Standard Warranty</b> .....	<b>60</b>
Mix Station Mode .....	20		
Prime the System .....	21		
<b>Operation</b> .....	<b>24</b>		
Ratio Check .....	24		
Dispensing .....	25		
<b>Cleanup</b> .....	<b>27</b>		
Wipe Down .....	27		
Flush the TruMix XT .....	28		
.....	30		
<b>Remove ProConnect Swappable Pumping System</b> .....	<b>31</b>		
<b>Replace ProConnect Swappable Pumping System</b> .....	<b>32</b>		
<b>Storage</b> .....	<b>34</b>		

## Models

Part	Description	Approvals	
			
2003102	TruMix XT, 120V		
2003103	TruMix XT, 230V	✓	✓

## Related Manuals

English Manual Number	Description
3B0282	Pump Repair Manual

# Important Grounding Information

The following information is intended to help you understand when to use the grounding wire and clamp provided with your system. It is required when flushing or cleaning with flammable materials.



Please read the information on the material container label to determine if it is flammable. Ask for a Safety Data Sheet (SDS) from your supplier. The container label and SDS will explain the contents of the material and the specific precautions related to it.









Flushing and clean-up materials generally fit into one of the following **3 basic types**:

Grounding Wire and Clamp Required?	Type of Flushing or Cleaning Material
<p><b>Yes</b></p> 	<p><b>FLAMMABLE:</b> This type of material contains flammable solvents such as xylene, toluene, naphtha, MEK, lacquer thinner, acetone, denatured alcohol, and turpentine. The container label should indicate that this material is <b>FLAMMABLE</b>. Use flammable materials outdoors or in a well-ventilated area with a flow of fresh air. Follow <b>Grounding</b>, page 16, when using this type of material.</p>
<p><b>No</b></p>	<p><b>OIL-BASED:</b> The container label should indicate that the material is <b>COMBUSTIBLE</b> and can be cleaned up with mineral spirits or non-flammable paint thinner.</p>
<p><b>No</b></p>	<p><b>WATER:</b> The container label of the material being applied should indicate that it can be cleaned with soap and water.</p>

# Safety Symbols

The following safety symbols appear throughout this manual and on warning labels. Read the table below to understand what each symbol means.

Symbol	Meaning
	Burn Hazard
	Electric Shock Hazard
	Equipment Misuse Hazard
	Fire and Explosion Hazard
	Moving Parts Hazard
	Pressurized Equipment Hazard
	Splash Hazard
	Toxic Fluid or Fumes Hazard

Symbol	Meaning
	Do Not Expose to Water or Rain
	Eliminate Ignition Sources
	Follow Pressure Relief Procedure
	Ground Equipment
	Read Manual
	Unplug Equipment
	Ventilate Work Area
	Wear Personal Protective Equipment













## Safety Alert Symbol





This symbol indicates: Attention! Become Alert! Look for this symbol throughout the manual to indicate important safety messages.

# General Warnings

The following warnings apply throughout this manual. Read, understand, and follow the warnings before using this equipment. Failure to follow these warnings can result in serious injury.

 <h2 style="margin: 0;">WARNING</h2>	
   	<p><b>FIRE AND EXPLOSION HAZARD</b></p> <p>Flammable fumes, such as solvent and paint fumes, in <b>work area</b> can ignite or explode. Paint or solvent flowing through the equipment can cause static sparking. To help prevent fire and explosion:</p> <ul style="list-style-type: none"> <li>• Use equipment only in well-ventilated area.</li> <li>• Eliminate all ignition sources, such as pilot lights, cigarettes, portable electric lamps, and plastic drop cloths (potential static sparking).</li> <li>• Ground all equipment in the work area. See <b>Grounding</b> instructions.</li> <li>• Never spray or flush solvent at high pressure.</li> <li>• Keep work area free of debris, including solvent, rags and gasoline.</li> <li>• Do not plug or unplug power cords, or turn power or light switches on or off when flammable fumes are present.</li> <li>• Use only grounded hoses.</li> <li>• Hold gun firmly to side of grounded pail when triggering into pail. Do not use pail liners unless they are anti-static or conductive.</li> <li>• <b>Stop operation immediately</b> if static sparking occurs or you feel a shock. Do not use equipment until you identify and correct the problem.</li> <li>• Keep a working fire extinguisher in the work area.</li> </ul>
  	<p><b>PRESSURIZED EQUIPMENT HAZARD</b></p> <p>Fluid from the equipment, leaks, or ruptured components can splash in the eyes or on skin and cause serious injury.</p> <ul style="list-style-type: none"> <li>• Follow the <b>Pressure Relief Procedure</b> when you stop spraying/dispensing and before cleaning, checking, or servicing equipment.</li> <li>• Tighten all fluid connections before operating the equipment.</li> <li>• Check hoses, tubes, and couplings daily. Replace worn or damaged parts immediately.</li> </ul>
 	<p><b>ELECTRIC SHOCK HAZARD</b></p> <p>This equipment must be grounded. Improper grounding, setup, or usage of the system can cause electric shock.</p> <ul style="list-style-type: none"> <li>• Turn off and disconnect power cord before servicing equipment.</li> <li>• Connect only to grounded electrical outlets.</li> <li>• Use only 3-wire extension cords.</li> <li>• Ensure grounded prongs are intact on power and extension cords.</li> <li>• Do not expose to rain. Store indoors.</li> <li>• Wait five minutes after disconnecting power cord before servicing.</li> </ul>

# ! WARNING

 	<p><b>MOVING PARTS HAZARD</b>                  Moving parts can pinch, cut or amputate fingers and other body parts.</p> <ul style="list-style-type: none"> <li>• Keep clear of moving parts.</li> <li>• Do not operate equipment with protective guards or covers removed.</li> <li>• Equipment can start without warning. Before checking, moving, or servicing equipment, follow the <b>Pressure Relief Procedure</b> and disconnect all power sources.</li> </ul>
 	<p><b>EQUIPMENT MISUSE HAZARD</b>                  Misuse can cause death or serious injury.</p> <ul style="list-style-type: none"> <li>• Do not operate the unit when fatigued or under the influence of drugs or alcohol.</li> <li>• Do not exceed the maximum working pressure or temperature rating of the lowest rated system component. See <b>Technical Specifications</b> in all equipment manuals.</li> <li>• Use fluids and solvents that are compatible with equipment wetted parts. See <b>Technical Specifications</b> in all equipment manuals. Read fluid and solvent manufacturer's warnings. For complete information about your material, request Safety Data Sheets (SDSs) from distributor or retailer.</li> <li>• Do not leave the work area while equipment is energized or under pressure.</li> <li>• Turn off all equipment and follow the <b>Pressure Relief Procedure</b> when equipment is not in use.</li> <li>• Check equipment daily. Repair or replace worn or damaged parts immediately with genuine manufacturer's replacement parts only.</li> <li>• Do not alter or modify equipment. Alterations or modifications may void agency approvals and create safety hazards.</li> <li>• Make sure all equipment is rated and approved for the environment in which you are using it.</li> <li>• Use equipment only for its intended purpose. Call your distributor for information.</li> <li>• Route hoses and cables away from traffic areas, sharp edges, moving parts, and hot surfaces.</li> <li>• Do not kink or over bend hoses or use hoses to pull equipment.</li> <li>• Keep children and animals away from work area.</li> <li>• Comply with all applicable safety regulations.</li> </ul>
	<p><b>BURN HAZARD</b>                  Equipment surfaces and fluid that is heated can become very hot during operation. To avoid severe burns:</p> <ul style="list-style-type: none"> <li>• Do not touch hot fluid or equipment.</li> </ul>

# ⚠️ WARNING



## **BATTERY HAZARD**

The battery may leak, explode, cause burns, or cause an explosion if mishandled. Contents of an open battery can cause severe irritation and/or chemical burns. If on skin, wash with soap and water. If in eyes, flush with water for at least 15 minutes and get immediate medical attention.

- Replace battery only in a well-ventilated area and away from flammable or combustible materials, including paints and solvents.
- When battery is not in use, keep it away from metal objects like keys, nails, screws or other metal objects that can short circuit the battery terminals.
- Do not throw into fire.
- Charge only with Graco approved charger as listed in this manual.
- Do not store at temperatures below 32° or above 113 °F (0° to 45 °C).
- Do not use at temperatures below 40° or above 90 °F (4° to 32 °C).
- Do not expose battery to water or rain.
- Do not disassemble, crush, or penetrate the battery.
- Do not use or charge a battery that is cracked or damaged.
- Follow local ordinances and/or regulations for disposal.



## **CHARGER ELECTRIC SHOCK, FIRE AND EXPLOSION HAZARD**

Improper setup or usage can cause electric shock, fire, and explosion.



- Charge only in a well-ventilated area and away from flammable or combustible materials, including paints and solvents.
- Do not charge on a combustible or flammable surface.
- Do not leave battery unattended while charging.
- Immediately unplug charger and remove battery when charging is complete.
- Charge only Graco approved batteries listed in this manual; other batteries may burst.
- Use only in dry locations. Do not expose to water or rain.
- Do not use a charger that is cracked or damaged.
- If the supply cord is damaged, replace the charger or cord, depending on model.
- Never force the battery into the charger.
- Disconnect the charger from the outlet before cleaning.
- Ensure that the outside surface of the battery is clean and dry before plugging into the charger.
- Do not attempt to charge non-rechargeable batteries.
- Do not disassemble the charger. Take charger to authorized service center when service or repair is required.



# **WARNING**



## **TOXIC FLUID OR FUMES HAZARD**

Toxic fluids or fumes can cause serious injury or death if splashed in the eyes or on skin, inhaled or swallowed.

- Read Safety Data Sheets (SDSs) for handling instructions and to know the specific hazards of the fluids you are using, including the effects of long-term exposure.
- When spraying, servicing equipment, or when in the work area, always keep work area well-ventilated and always wear appropriate personal protective equipment. See **Personal Protective Equipment** warnings in this manual.
- Store hazardous fluid in approved containers, and dispose of it according to applicable guidelines.



## **PERSONAL PROTECTIVE EQUIPMENT**

Always wear appropriate personal protective equipment and cover all skin when spraying, servicing equipment, or when in the work area. Protective equipment helps prevent serious injury, including long-term exposure; inhalation of toxic fumes, mists or vapors; allergic reaction; burns; eye injury and hearing loss. This protective equipment includes but is not limited to:

- A properly fitting respirator, which may include a supplied-air respirator, chemically impermeable gloves, protective clothing and foot coverings as recommended by the fluid manufacturer and local regulatory authority.
- Protective eyewear and hearing protection.

# Important Information

## Overview

The TruMix XT Variable Ratio Mixing System pumps and mixes two-component materials:

- Material from 1:1 to 6:1 ratios in 0.01 increments.
- Dispenses either continuously or in user-specified batch volumes.
- May be utilized in a mobile dispense mode to dispense coatings from five gallon material supply buckets in smaller areas.
- May be utilized in a stationary mix station mode as a fixed dispensing station with large material supply buckets, useful in coating large floors.
- See, **Setup**, page 19, for explanation of stationary mix station or mobile dispensing.
- The ProConnect Swappable Pumping System allows for quick changing of pumps due to material incompatibility or for ease of repairs, see **Remove ProConnect Swappable Pumping System**, page 31.

## Material Compatibility

- Materials must be kept on intended side of system. DO NOT cross contaminate.
- System has been designed to accommodate incompatible material chemistries through the use of removable, dedicated ProConnect Swappable Pumping Systems.

## Keep Components A and B Separate



Cross-contamination can result in cured material in fluid lines which could cause serious injury or damage equipment. To prevent cross-contamination:

- Never interchange component A and component B wetted parts.
- Never use solvent on one side if it has been contaminated from the other side. Never cross solvent A and B.

### NOTICE

TruMix XT only pumps non-aggregated A&B component materials. To prevent damage:

- DO NOT supply pumps with catalyzed materials.
- DO NOT mix in proximity of machine to prevent splattering cross contamination.
- DO NOT combine mixed material with aggregates in proximity to machine to prevent aggregates from clogging pumps.

## A (Blue) and B (Red) Components

**NOTE:** Material suppliers can vary in how they refer to plural component materials.

Be aware that when standing in front the user controls at the system handle bars:

- Component A (Blue) is on the left side.
- Component B (Red) is on the right side.

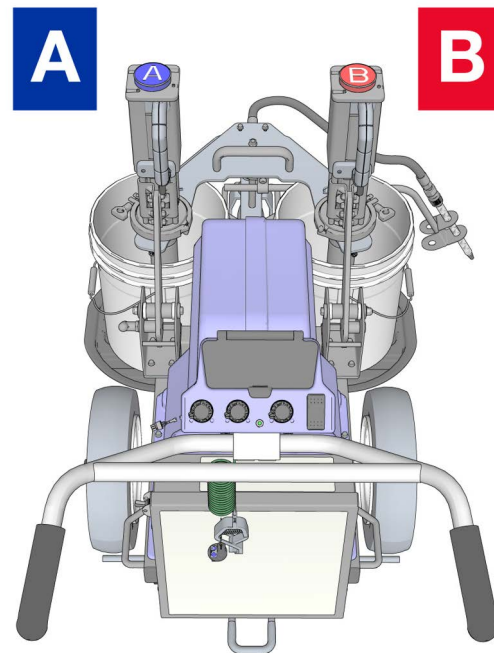

101487a

## Changing Materials

### NOTICE

Changing the material types used in your equipment requires special attention to avoid equipment damage and downtime.

- When changing materials, flush the equipment multiple times to ensure it is thoroughly clean.
- Check with your material manufacturer for chemical compatibility.
- To prevent damage, use separate ProConnect Swappable Pumping Systems for incompatible materials, such as epoxies, polyurethanes, and polyaspartics, see **Remove ProConnect Swappable Pumping System**, page 31.

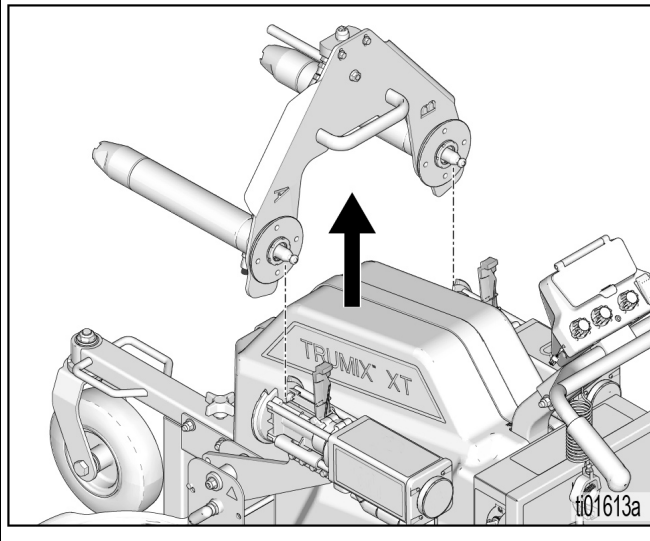

## Moisture Sensitive Materials

Exposure to moisture (such as humidity) will cause moisture sensitive materials to partially cure. Over time, the material will increase in viscosity and fully harden.

### NOTICE

Partially cured material will reduce performance and the life of all wetted parts.

- Keep pump wet cup filled with appropriate lubricant. The lubricant creates a barrier between the material and the atmosphere.
- Never use reclaimed solvents, which may contain moisture. Always keep solvent containers closed when not in use.
- Always lubricate threaded parts with an appropriate lubricant when reassembling.

# Component Identification

## TruMix XT

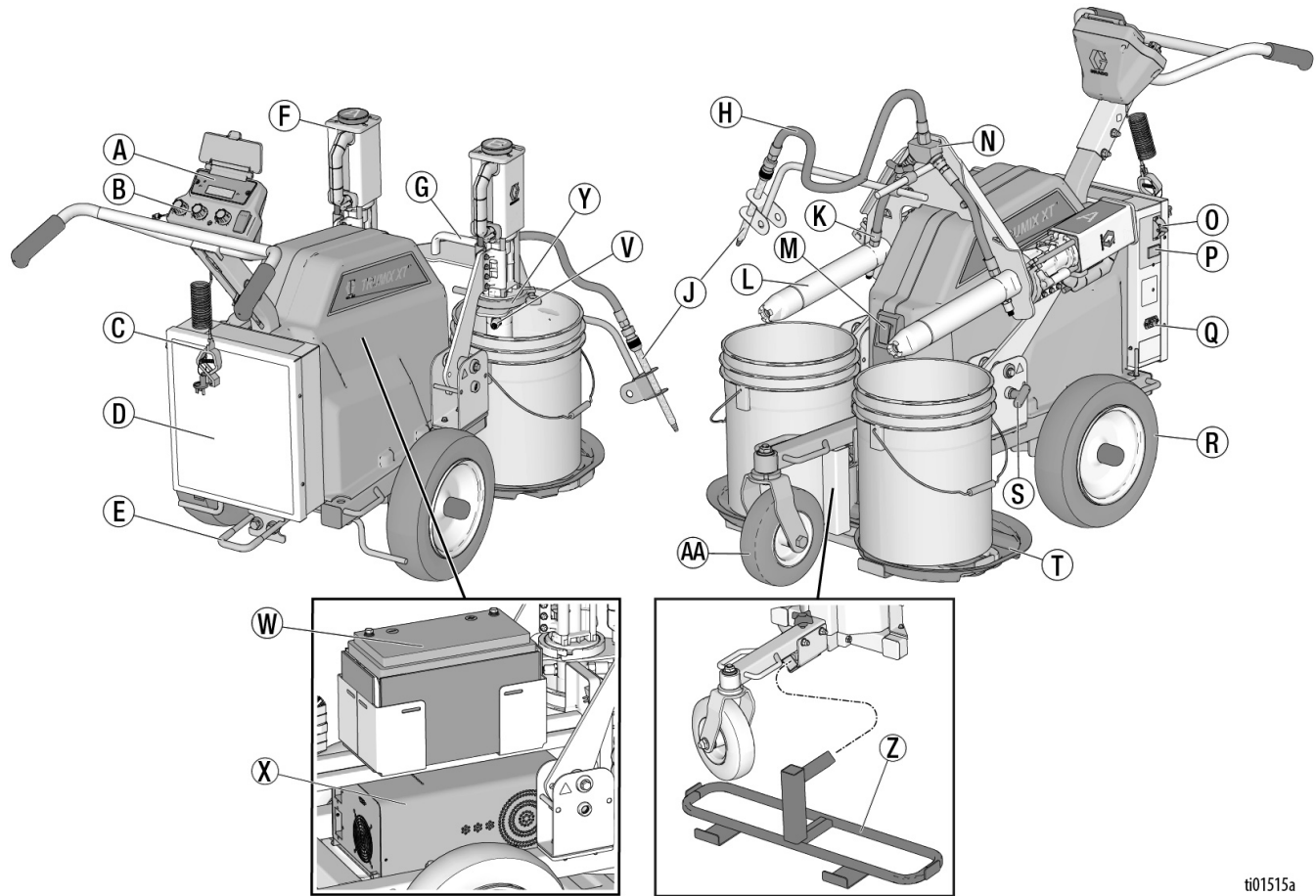

ti01515a

A	Digital Display, see pg. 13
B	User Controls
C	Grounding Wire
D	System Control Enclosure
E	Brake
F	XT Extreme Torque Driver
G	ProConnect™ Handle (Tilt and Carry)
H	CrossLink™ Multi-Stage Mix Hose
J	Applicator
K	A/B Component Material Hoses
L	ProConnect Swappable Pumping System
M	Mix Station Mode Dispense Switch
N	Dispense Manifold (with check valves)

O	ON/OFF Switch
P	Battery Voltage Meter
Q	Battery Charging/Power Port
R	Rear Wheel
S	Pump Tilt Release
T	Spill Catch Bucket Tray
V	Pressure Transducer
W	Battery (Lithium Ion)
X	Inverter/Charger
Y	ProConnect Clamp
Z	Removable Bucket Holder
AA	Front Wheel

## Digital Display



ti01516a

A	System Information Screen
B	Left Menu Button
C	Right Menu Button
D	System Error Indicator Light
E	Pump Mode Knob - Park, A, B, A:B

F	Batch Volume Knob
G	RatioGuard Indicator Light
H	Flow Speed Knob
J	Dispense Switch - Mobile

## Universal Display Operations

### Left Menu Button

In Edit Mode:

- Short Press: Decrease value slowly.
- Hold (> 1 second): Decrease value rapidly.

Outside of Edit Mode:

- Short Press: Move to previous menu item.
- Hold (> 5 seconds): Switch between primary menu and secondary menu.

### Right Menu Button

In Edit Mode:

- Short Press: Increase value slowly.
- Hold (> 1 second): Increase value rapidly.

Outside of Edit Mode:

- Short Press: Move to next menu item
- Hold (> 1 second): No action

### Both Menu Buttons

- Short Press or Hold (>1 second): Enter/exit edit mode, reset totalizer, or perform action (if applicable).

**NOTE:** Display flashes the value being edited in edit mode.

**NOTE:** If editing ratio numerator (part A), short pressing both buttons will advance to edit the ratio denominator (part B). If editing ratio denominator (part B), short pressing both buttons will exit edit mode.

### Menu Notes

- While in the primary menu, the display will return to “1-RATIO” after five seconds without display interaction.
- Changing the Pump Mode or Batch Volume Knob while in the primary menu will cause the display to immediately navigate to “1-RATIO” or “2-BATCH SETTING” and show the current value of the setting.
- Changing the volume units will cause the custom batch setting to revert to the default value for the units selected (4.00 gallons or 16.00 L).
- The job volume reset prompt will only appear once per power cycle after the completion of the ratio check. This prompt will not appear if ratio has been changed from the previous job. In this case, the job volumes will have automatically reset.
- The batch switch will only dispense material when the Pump Mode Knob is in the A:B position.

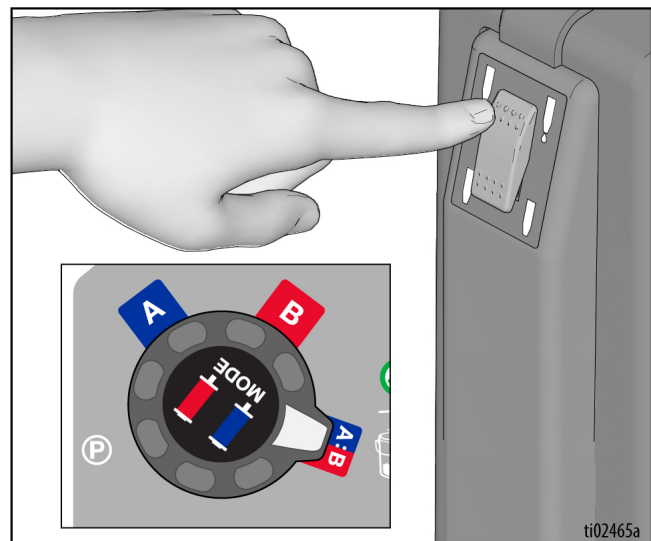

# Pressure Relief Procedure

 Follow the Pressure Relief Procedure whenever you see this symbol.

			
<p>To help prevent serious injury from pressurized fluid and splashing, follow the <b>Pressure Relief Procedure</b> if you suspect pressure has been trapped from a clogged hose.</p>			

1. Cover with a rag to prevent splashing and carefully loosen CrossLink™ Multi-Stage Mix Hose fitting to allow fluid to leak out. Be careful and wear appropriate PPE as material may splash when fitting is loosened.

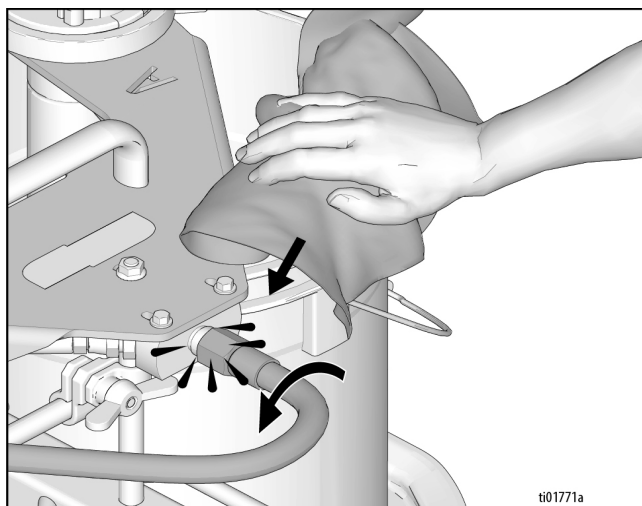

2. Wait for material to stop leaking from fitting.

3. Remove hose and discard.

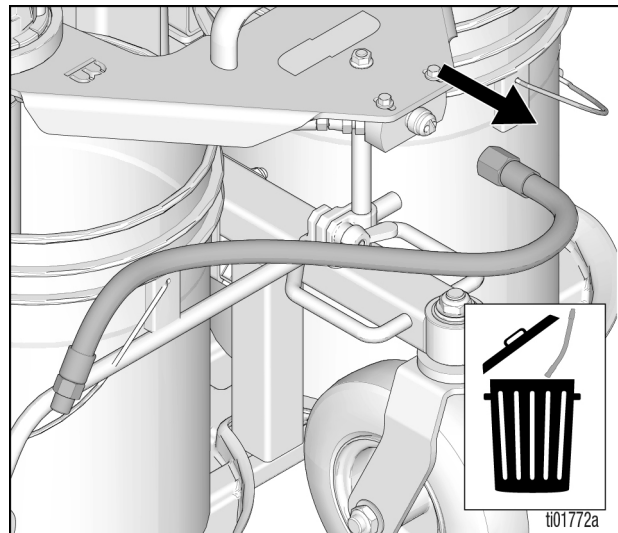



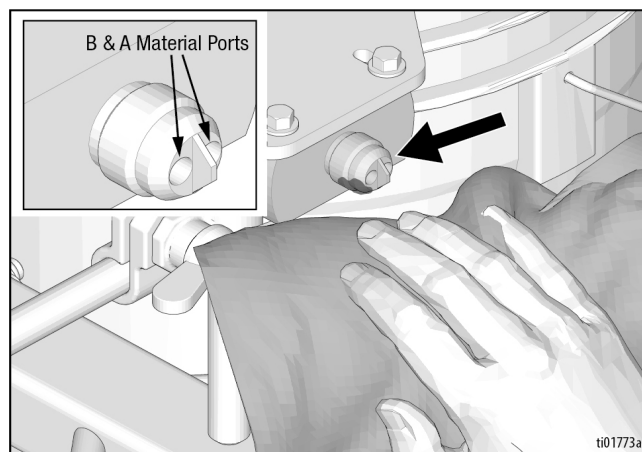

4. Clean Dispense Manifold B and A ports.



5. Replace CrossLink Multi-Stage Mix Hose.
6. Using a wrench, hand-tighten fittings.

# Grounding

				
<p>The equipment must be grounded to reduce the risk of static sparking and electric shock. Electric or static sparking can cause fumes to ignite or explode. Improper grounding can cause electric shock. Grounding provides an escape wire for the electric current.</p>				

Position the system so the wheels are on a true grounded surface, not on pavement or in the back of a trailer or a truck.

The system is equipped with a grounding wire and clamp. The clamp must be connected to a true earth ground when flushing with flammable materials. See **Important Grounding Information**, page 4.

Plug the adapter in to a grounded outlet. Connect the grounding wire (GW) and clamp (GC) to the metal stud on the adapter. If the ground wire is not long enough to reach a grounded electrical outlet, use a 3-wire grounded extension cord between the adapter and outlet.

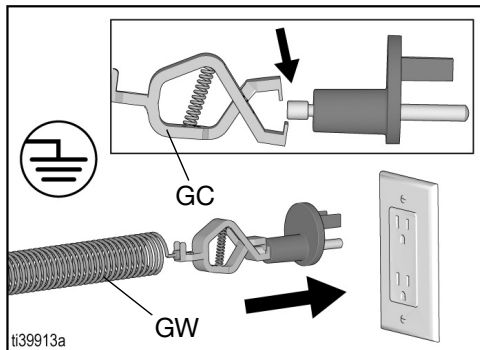

Use an extension cord with an undamaged ground contact. If an extension cord is necessary, use a 3-wire, 12 AWG (2.5 mm<sup>2</sup>) minimum.

## Pails

**Flammable materials:** follow local codes and regulations. Use only conductive metal pails, placed on a grounded surface such as concrete.

Do not place pail on a non-conductive surface such as paper or cardboard which interrupts grounding continuity.

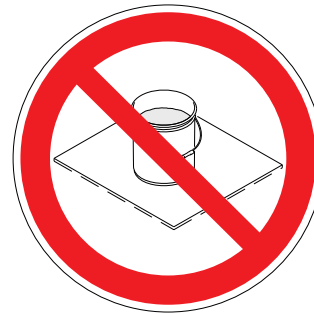



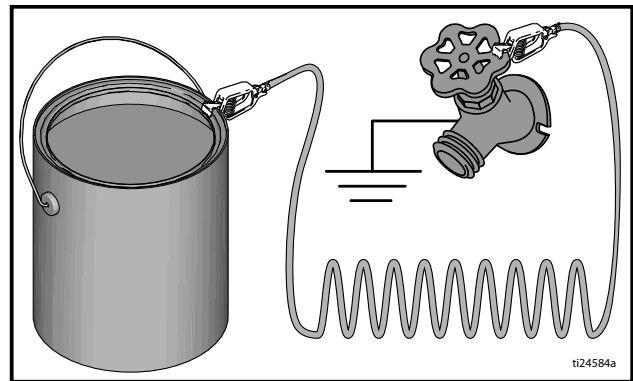

**Always ground a metal pail:** connect a ground wire (GW) to the pail. Clamp one end to the pail and the other end to a true earth ground such as a water pipe.



Use an extension cord with an undamaged ground contact. If an extension cord is necessary, use a 3-wire, 12 AWG (2.5 mm<sup>2</sup>) minimum.



# Battery and Charger

				
<p>The equipment must be grounded to reduce the risk of static sparking and electric shock. Electric or static sparking can cause fumes to ignite or explode. Improper grounding can cause electric shock. Grounding provides an escape wire for the electric current.</p>				

**NOTE:** If the battery level is below 10.0V, the unit will shut down and must be plugged in to restart.

NOTICE	
	<p>Do not expose the system to rain or wash down. Exposure could cause damage to electrical components. Store and transport covered or indoors.</p>

Use your smartphone's camera to scan and download the Power Sonic Quick Guide and Battery App.



For best performance, Graco recommends using only lithium ion batteries. The system is shipped with a Power Sonic Lithium (LiPO4) battery. If powering the system with lithium batteries, Graco recommends using the Power Sonic brand.

The unit is shipped with a Power Sonic Lithium battery. Use switch position 2 on the battery type selector. If a battery type other than Power Sonic is being used, the switch position will need to be adjusted. Use a small flathead screwdriver to turn the arrow to point to the number that correlates with the chosen battery.

## Check Level

Check battery level on the Power Sonic Smart Battery app. New batteries are approximately 50% capacity for shipping.

## Battery Disposal

See **Recycling and Disposal**, page 59.

## Charge the Battery



The equipment must be grounded to reduce the risk of static sparking and electric shock. Electric or static sparking can cause fumes to ignite or explode. Improper grounding can cause electric shock. Grounding provides an escape wire for the electric current.

1. Place the TruMix XT in a dry, well-ventilated area and away from flammable or combustible materials, including paint and solvent.
2. Turn the ON/OFF Switch to the **OFF** position.

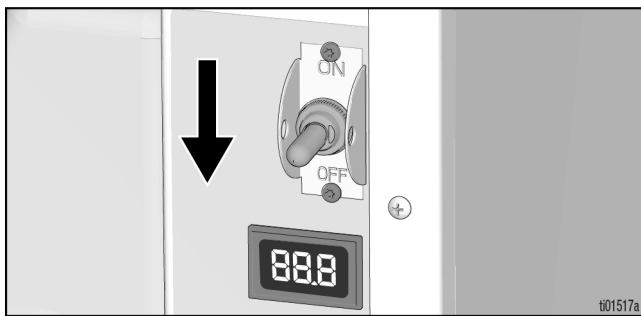

3. Plug charging cord into the battery charge port. Connect an extension cord, minimum 12AWG (2.5 mm<sup>2</sup>), to the charging cord and plug it into power.

**NOTE:** Use cord with lighted plug for indication charging cord is plugged into an active circuit.

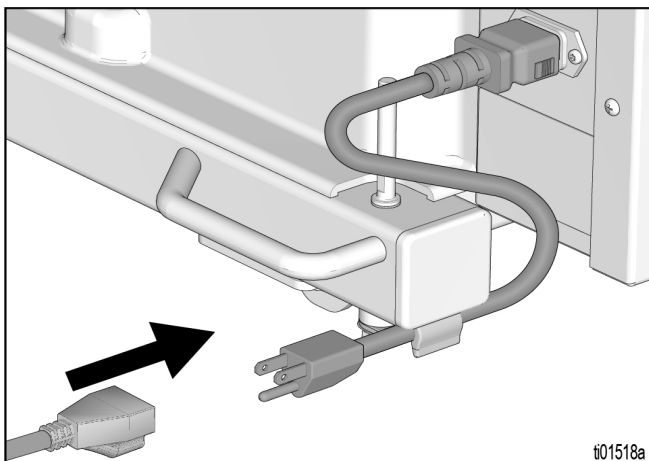

4. When connected to power, the voltmeter will turn on and the unit will begin charging. The voltmeter will indicate charging is occurring. The battery will charge to 14.6-14.8 volts and then descend to ~13.6 volts when fully charged.

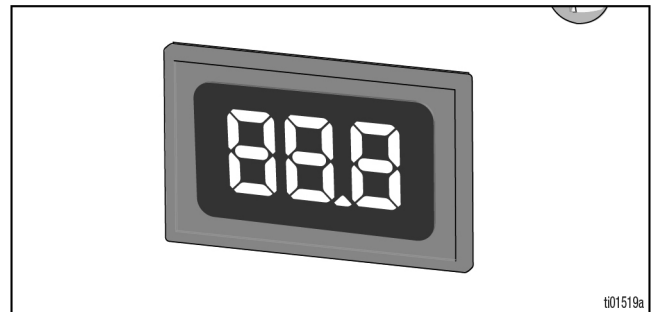

5. Unplug the charging cord.

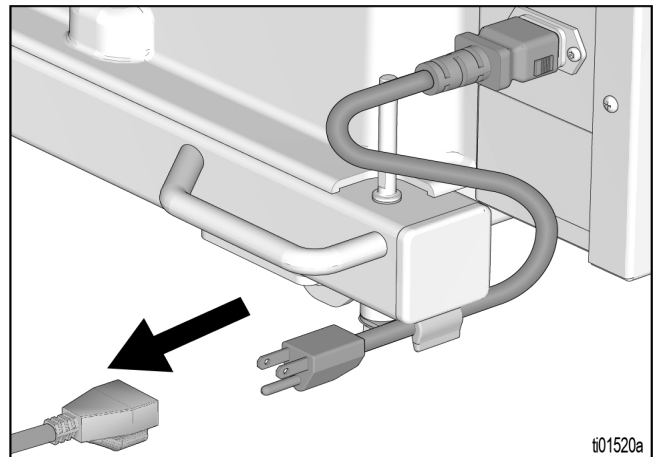

# Setup

## Startup

**NOTE:** The TruMix XT is shipped with caps on the end of the pumps. Prior to the first setup, remove and dispose of end caps.

1. Turn ON/OFF Switch to **ON**.

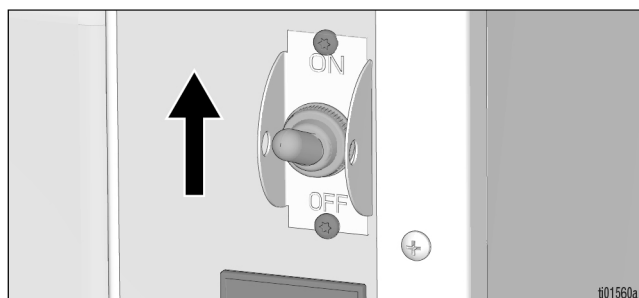

2. The Digital Display will scroll text until the system is ready. The screen will stop on the current ratio targets.



## Setup Ratios

1. Rotate Pump Mode Knob to the A:B position.
2. Press both menu buttons at the same time and release to edit the **A** side ratio volume.



Press the left menu button to decrease the ratio value or the right menu button to increase the ratio value.

**NOTE:** Values can be increased by 0.01 with a single press of the button or hold for faster cycling, see **Universal Display Operations**, page 14.

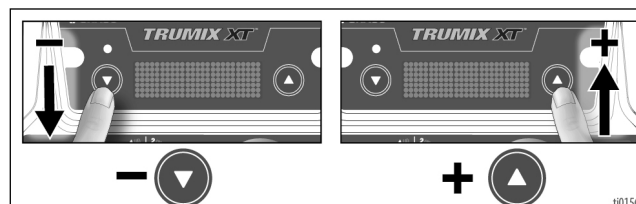

3. Press both menu buttons at the same time again to lock in the volume of the A side ratio. This also allows you to now edit the **B** side ratio volume.



4. Use the menu buttons to select the desired ratio for the **B** side, then push both menu buttons at the same time again to lock in the volume of the **B** side ratio.

## Mobile Dispense Mode

Mobile Dispense Mode is the default setup for the TruMix XT. In this mode the user can maneuver the TruMix XT to the desired area for application from five gallon supply buckets mounted on the Spill Catch Bucket Tray.

Mobile Dispense Mode is useful for smaller volume applications and in areas where a direct application may be beneficial.

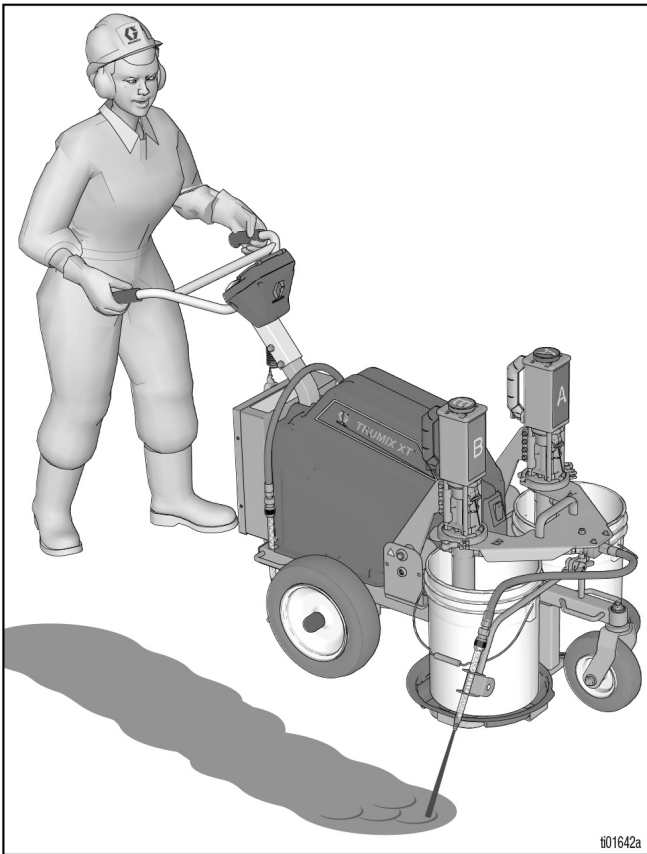

## Mix Station Mode

The TruMix XT has a Removable Bucket Holder that allows it to pump from a wide variety of higher-capacity containers to reduce time spent refilling. To use the TruMix XT as a stationary mix station, follow these steps:

1. Remove bucket holder by turning front wheel forward, loosening bucket holder knob, and slide the bucket holder out of the frame receiver.

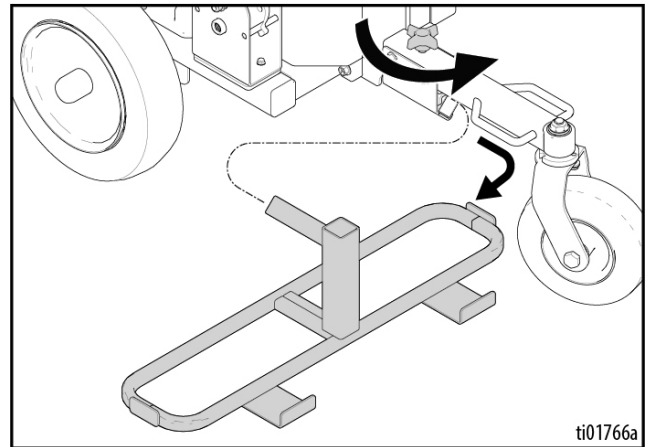

2. Place new containers under each pump.

**NOTE:** If material is packaged in drums or totes, be sure the new containers fit under the material dispensing valves.

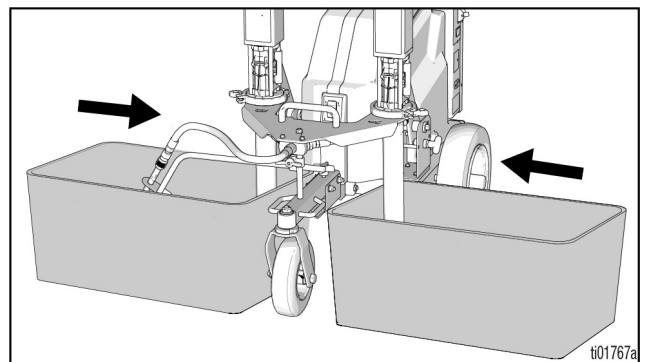

- Place A and B component material drums on carts and position over totes.

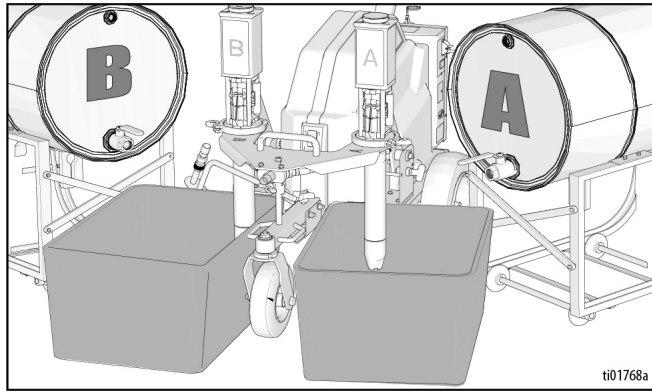

- Follow the prime procedure, see **Prime the System**, page 21, and resume operation.

## Prime the System

When solvents have been used to flush material from the previous job, a residual amount of solvent will remain in the pumps and hoses.

### NOTICE

Perform the following procedure to ensure that all solvent has been properly flushed. Failure to do so could cause material to improperly cure.

- Lock brake to prevent TruMix XT from rolling.
- Pull the Pump Tilt Release outward, then lift the ProConnect Handle to pivot the two pumps out of the material.

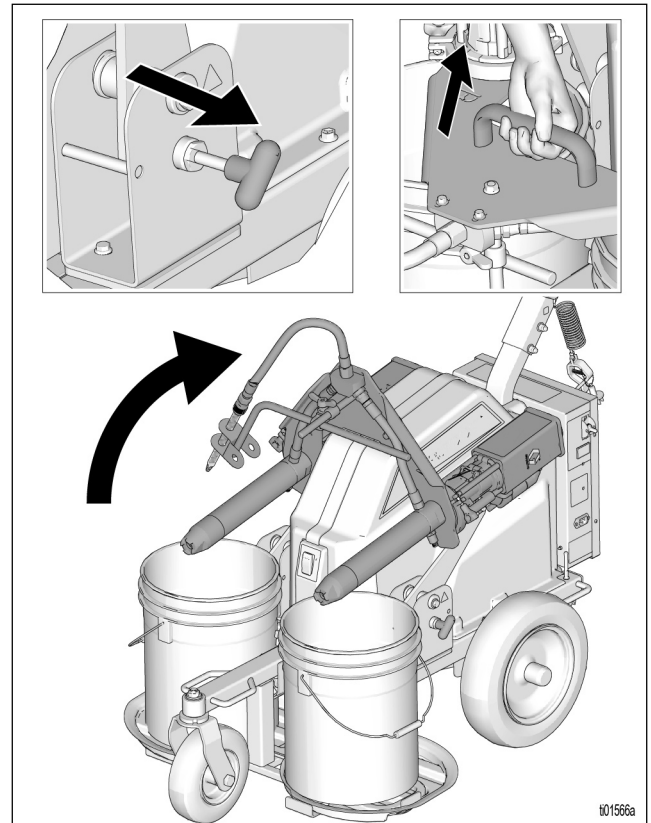

Setup

- Place pails with A and B materials to be applied onto the respective sides of the Removable Bucket Holder.

**NOTICE**

TruMix XT only pumps non-aggregated A and B component materials. To avoid equipment damage, DO NOT supply pumps with catalyzed materials.

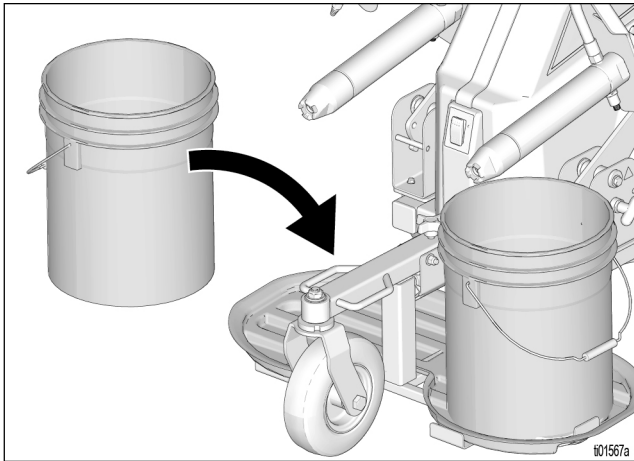

- Pull the Pump Tilt Release outward and pivot the two pumps downward into the material pails.

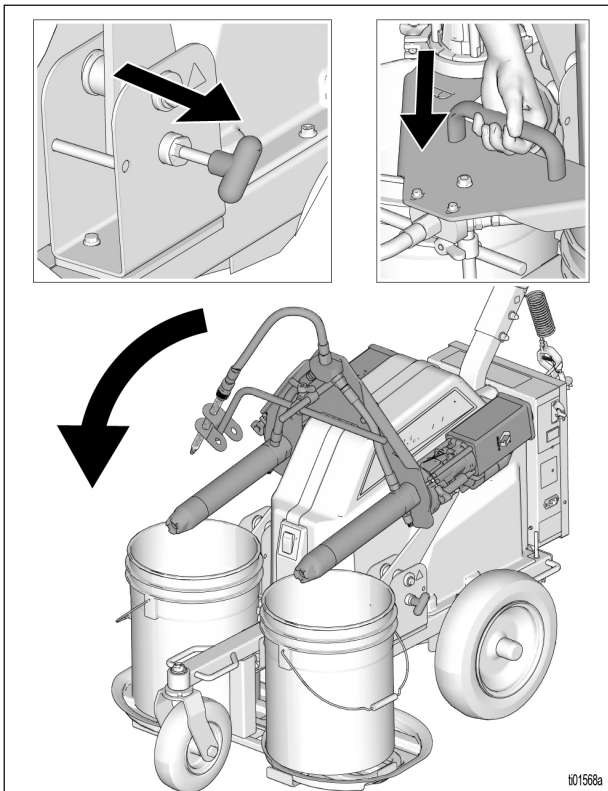

- Move the Pump Mode Knob to the **A:B** position.

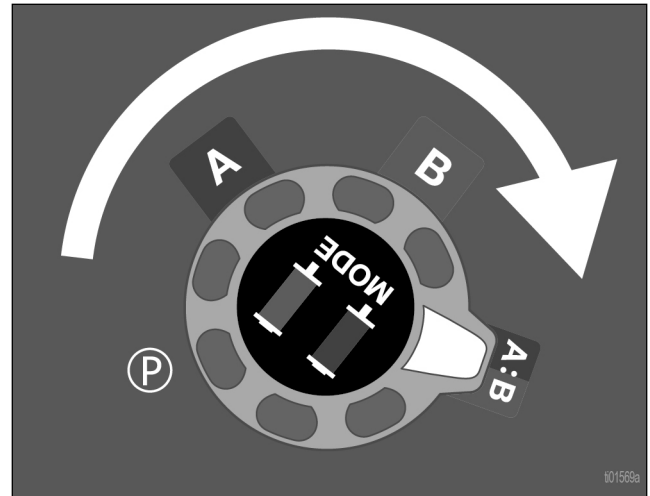

- Move the Batch Volume Knob to the Prime position.

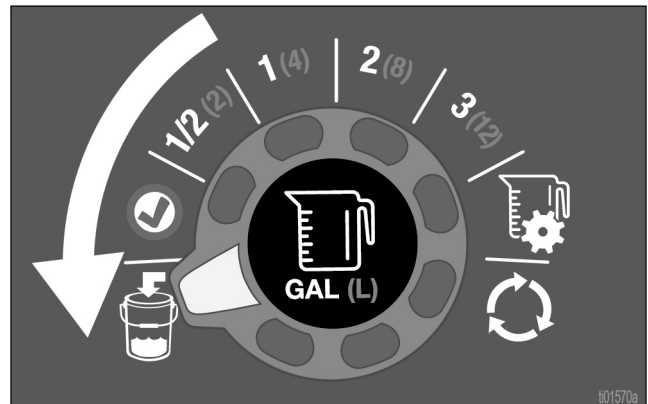

- Make sure the CrossLink Multi-Stage Mix Hose is installed on the Dispense Manifold.

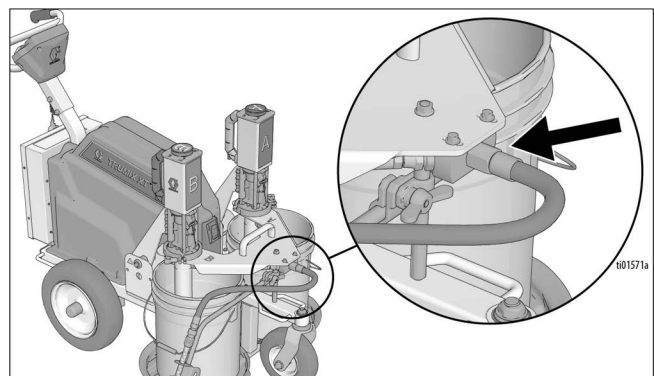

- Place a waste pail under the Applicator.

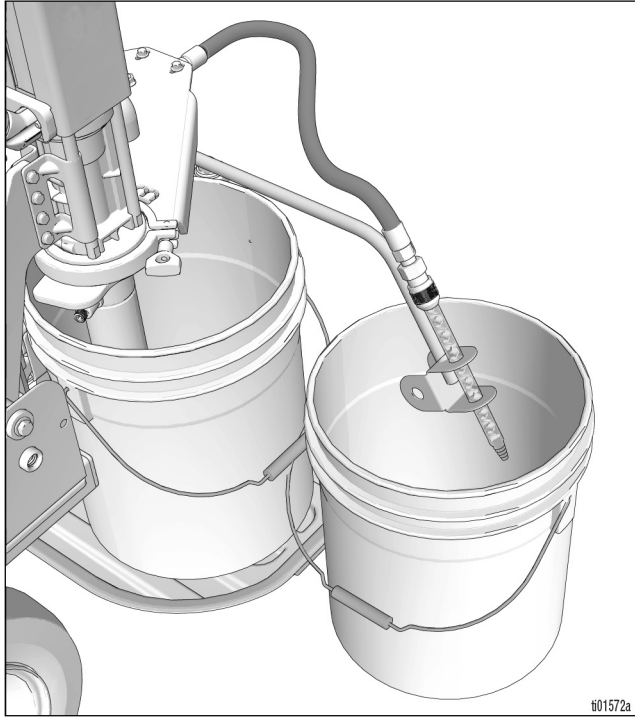

- Move the Flow Speed Knob to maximum flow.

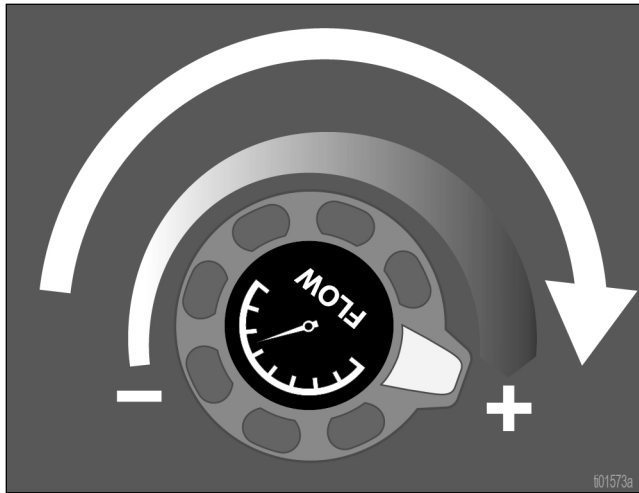

- Turn on the Dispense Switch. The system will begin to dispense material until both the A hose and B hose are full, and the CrossLink Multi-Stage Mix Hose is completely purged. The display screen will scroll "PRIME A:B COMPLETE" once complete. The system is now ready for the ratio check step.



# Operation

## Ratio Check



1. Move the Batch Volume Knob from the Prime position to Ratio Check.

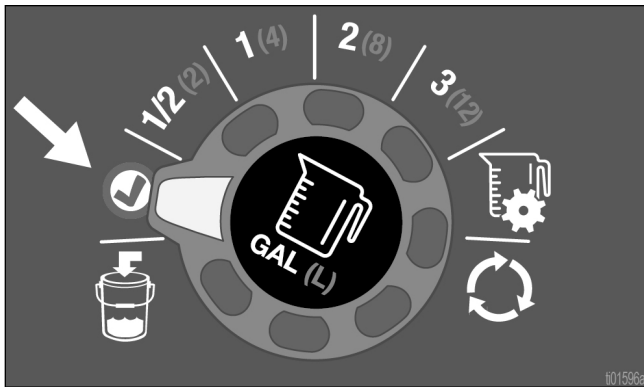

2. Place ratio check cup under tip of Applicator.
3. Turn the Dispense Switch **OFF** then back **ON** to start dispensing the ratio check material into the ratio check cup. The system will automatically stop dispensing when complete.

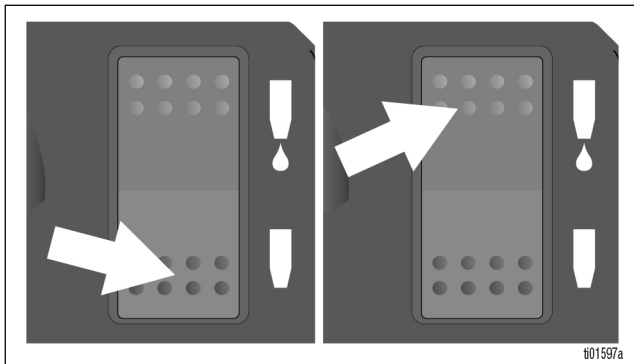

4. Visually verify that the correct amount of material (0.25 gallons or 1 liter) was dispensed. Select Yes (Y) or No (N) when prompted on the display screen, depending on whether or not the correct amount of material was dispensed. If the RatioGuard Indicator Light does not illuminate, the material should not be used for the end application and the system will need to be re-primed.



5. Once Yes (Y) has been selected, the green RatioGuard Indicator Light will illuminate.

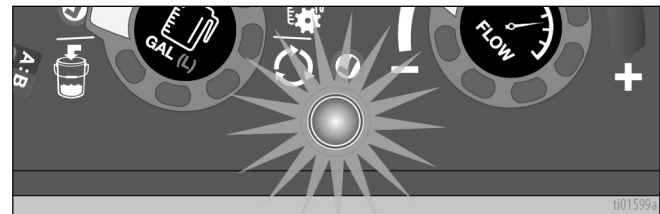

**NOTE:** As long as the green RatioGuard Indicator Light is illuminated, the system can dispense on ratio. Otherwise, the system must be re-primed and a new ratio check must be performed to dispense on ratio.

**NOTE:** If attempting to dispense in a mode not covered by ratio assurance (Park, A only, or B only), or in the Prime position on Batch Volume Knob, the unit will prompt asking if you want to exit ratio assurance. If “YES” is selected, the unit will need to be re-primed and a new ratio check will need to be performed in order to dispense on ratio.



## Dispensing

### Continuous Setting



When set to the continuous setting (the Batch Volume Knob turned fully to the right), the applicator will dispense an unlimited amount of material when the Dispense Switch is turned **ON**, as long as there is material in the pails.

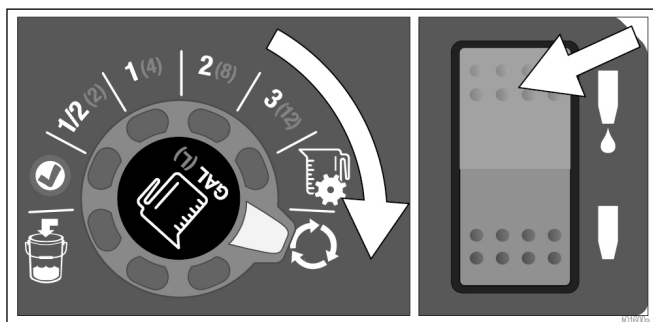

**NOTE:** Do not let material run out while the applicator is set to the continuous setting. The Digital Display will show “FEED ERROR” if material runs out. If this occurs, re-prime the system, see **Prime the System**, page 21.

### Batch Setting



When set to a specific batch volume setting, the TruMix XT will dispense the exact volume selected on the Batch Volume Knob.

**NOTE:** Ensure there is enough material in both the A and B pails to mix the total volume selected. Display screen will show “FEED ERROR” if material runs out. If this occurs, re-prime the system, see **Prime the System**, page 21.

1. Place Applicator into a clean, empty pail.

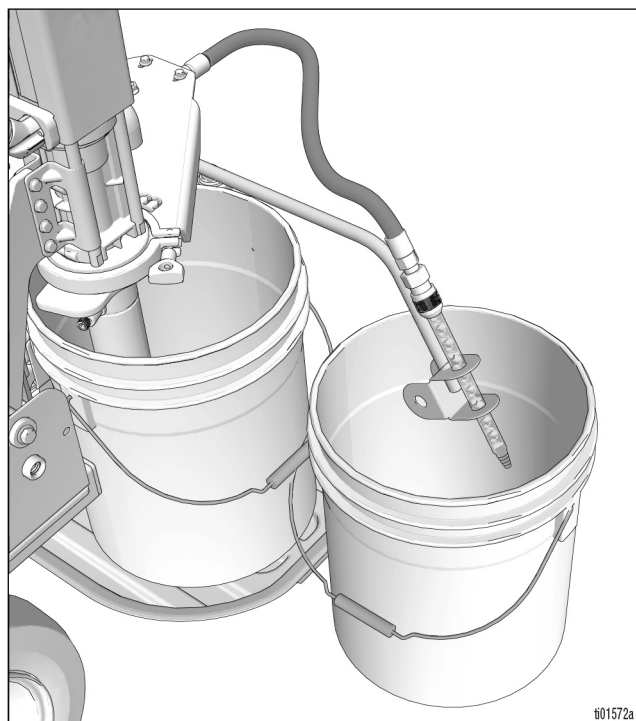

## Operation

2. Use the Batch Volume Knob to select the desired volume of material to be dispensed.

**NOTE:** The volume size will display for five seconds before returning to ratio size when knob is turned the appropriate value.

**NOTE:** For custom batch sizes, turn the Batch Volume Knob to custom batch. The last stored volume size will display when this option is selected. Double press the Menu Button to edit the volume size. Use individual presses or holds to increase or decrease the value.

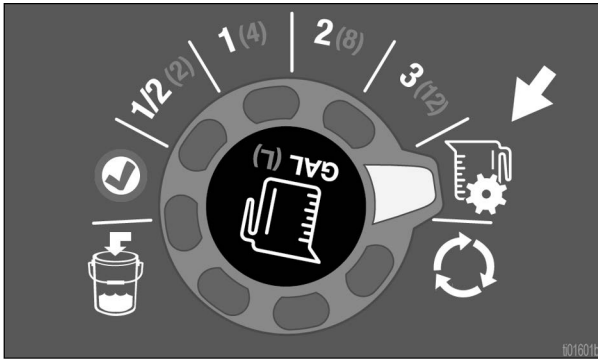

3. Turn the Dispense Switch to **ON** to start dispensing material. The system will automatically stop when the specified amount of mixed material has been dispensed, and "DISPENSE COMPLETE" will scroll across the System Information Screen.

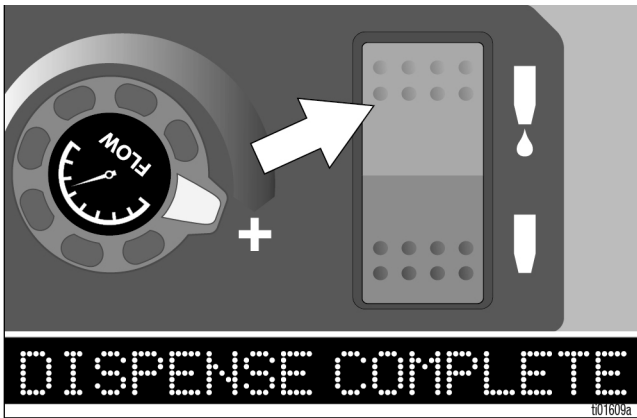

4. Turn the Dispense Switch **OFF**.

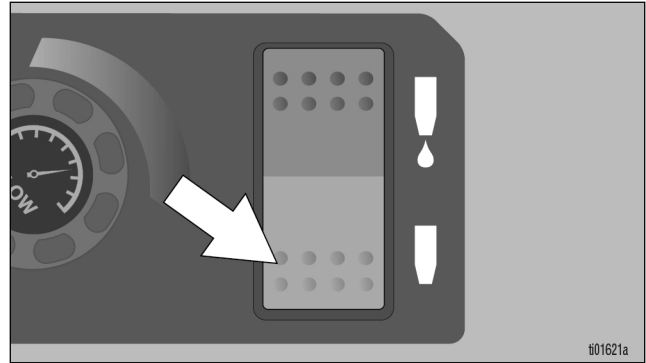

**NOTE:** In order to prevent dispensing off-ratio, the Mix Station Mode Dispense Switch on the front of the machine will only dispense material when the Pump Mode Knob is in the A:B position.

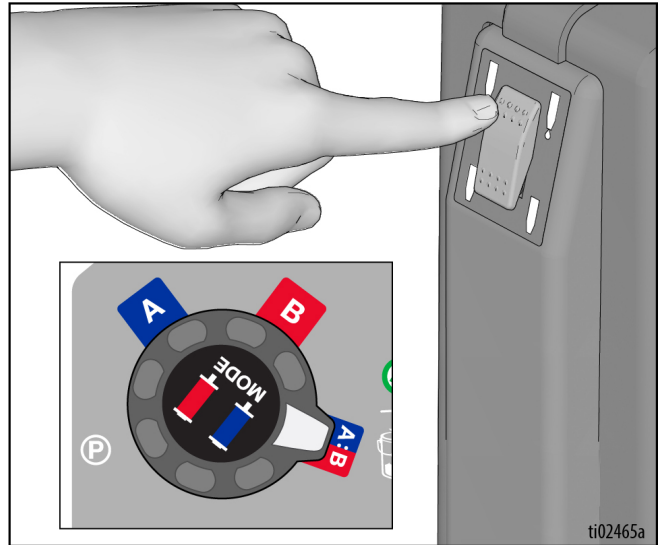

# Cleanup



The TruMix XT should be cleaned daily, when changing materials, or at the end of use.

**NOTE:** The pumps, hose, and applicator will still be full of material at the start of the cleaning process.

## Wipe Down

1. Pull the Pump Tilt Release outward, then lift the ProConnect Handle to pivot the two pumps out of the material.

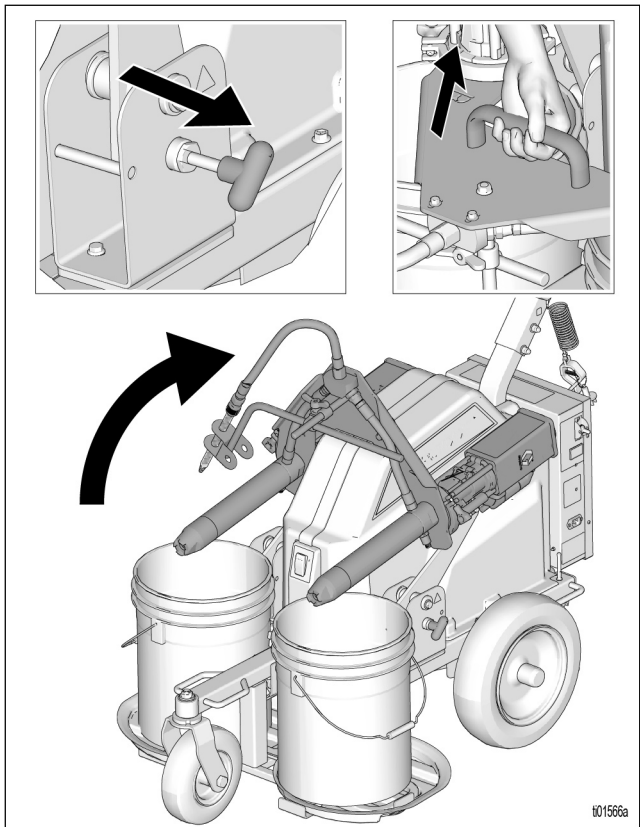

2. Using a clean cloth, wipe each pump individually to remove as much material as possible.

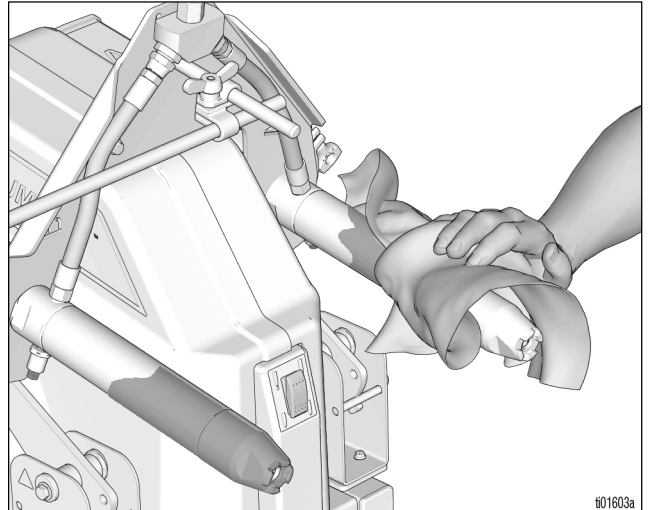

**NOTICE**

It is vital to use a separate, clean rag for each pump. Using the same rag to clean both the A and B pumps might activate the two-component mixtures and result in material curing on the pumps, resulting in potential damage.

## Flush the TruMix XT



To avoid fire and explosion, always ground equipment and waste container. To avoid static sparking and injury from splashing, always flush at the lowest possible pressure in a well ventilated area.

1. Follow the grounding procedure, see **Grounding**, page 16.
2. Remove material pails from the Removable Bucket Holder.
3. Replace material pails with pails containing an appropriate cleaning solvent. It is recommended flushing at least 0.5 gallons or 2 liters of solvent through each side of the system.

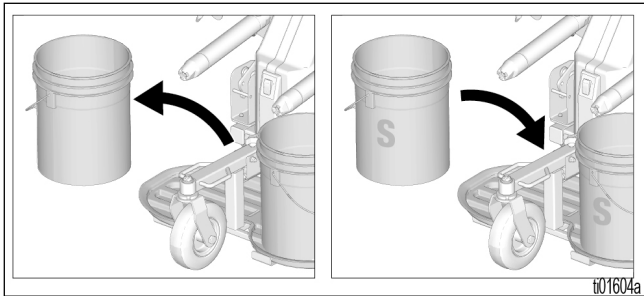

4. Pivot the pumps down into the solvent pails.

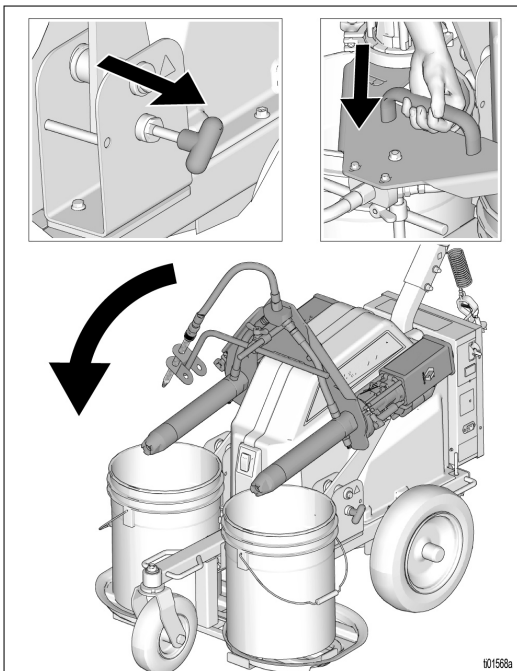

5. Place the Applicator into a waste pail.

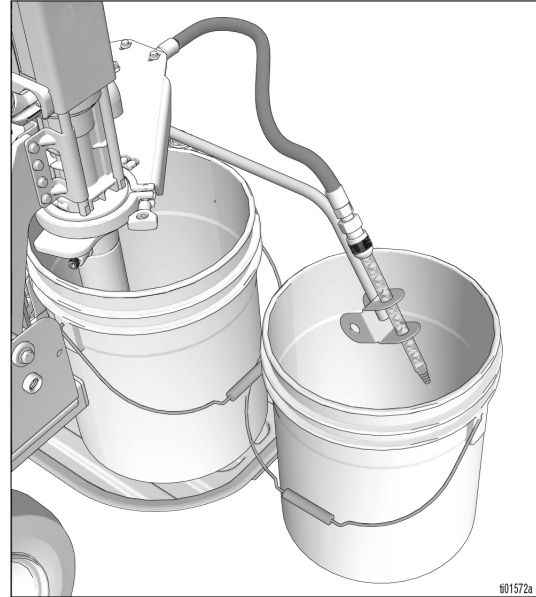

6. Move the Pump Mode Knob to the B position.

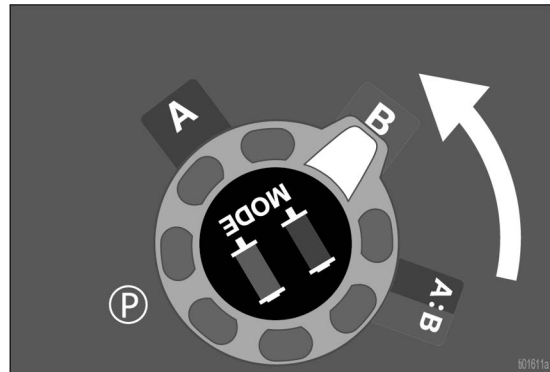

7. Set the Batch Volume Knob to the appropriate volume (minimum of one-half gallon). The amount of solvent needed may vary depending on the material used and the amount of color tinting added.

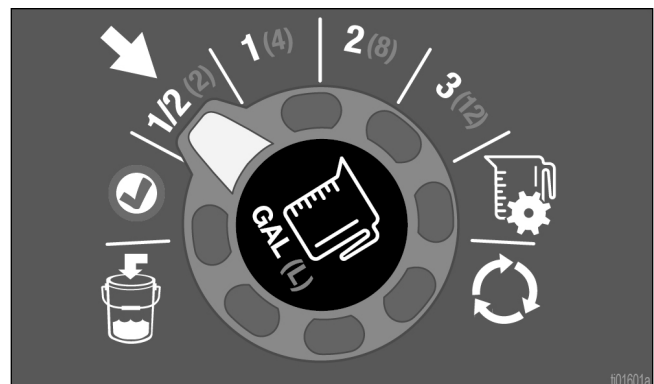

- 8. Set the Flow Speed Knob to the maximum setting (all the way to the right) to maximize the cleaning performance when flushing.

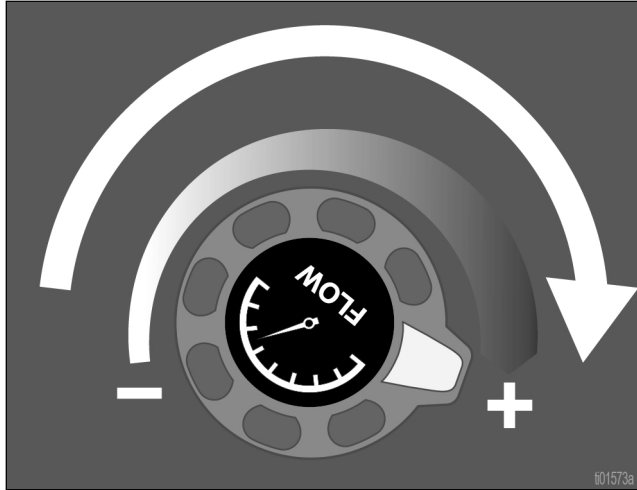

- 9. Turn the Dispense Switch to **ON**. Once the B pump has cycled the predetermined amount of solvent, “DISPENSE COMPLETE” will scroll across the System Information Screen.

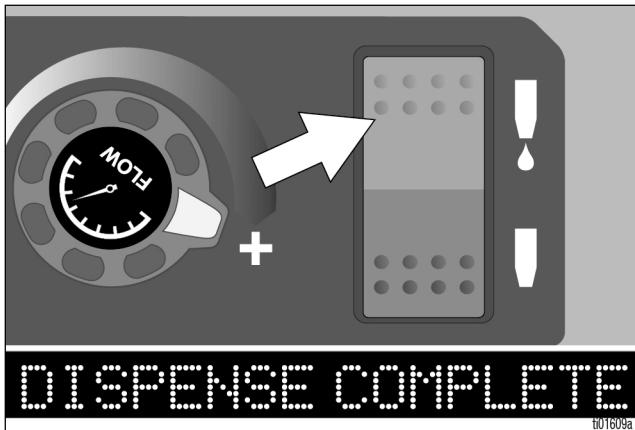

- 10. Turn the Dispense Switch **OFF**.

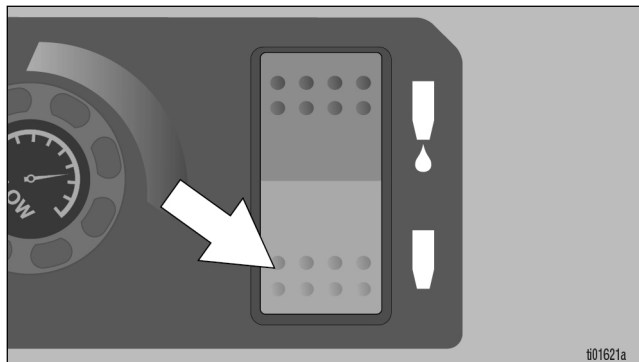

- 11. Move the Pump Mode Knob to the A position.

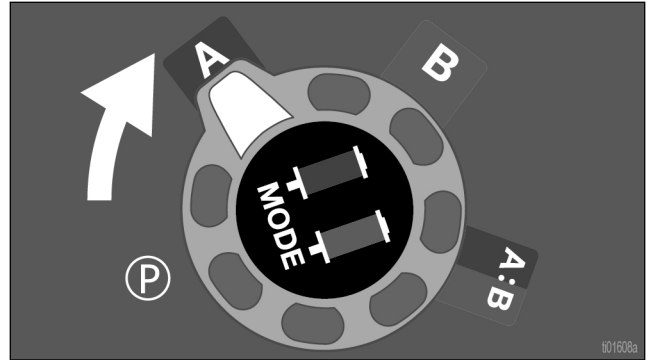

- 12. Turn the Dispense Switch to **ON**. Once the A pump has cycled the predetermined amount of solvent, “DISPENSE COMPLETE” will scroll across the System Information Screen.

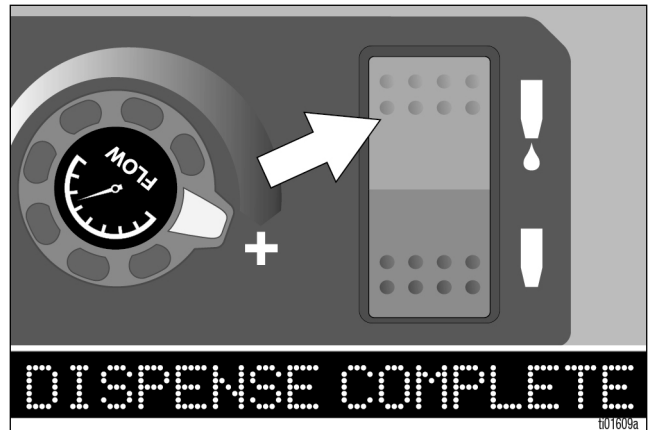

- 13. Turn the Dispense Switch **OFF**.

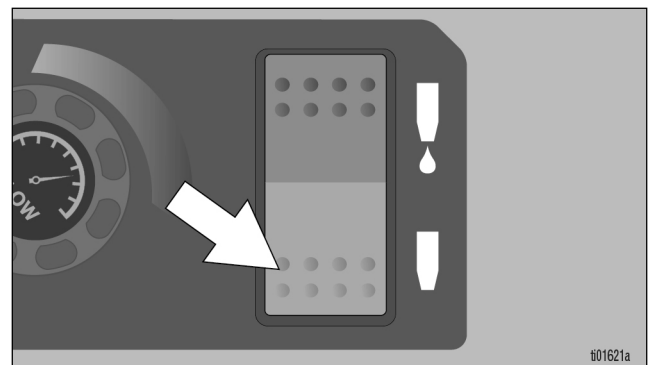

## Cleanup

14. Turn Pump Mode Knob to the Park Position (P). Turn Material Dispense Switch to **ON**. This will lower the pumps into the storage position for easy removal. "PARK COMPLETE" will scroll across the System Information Screen.

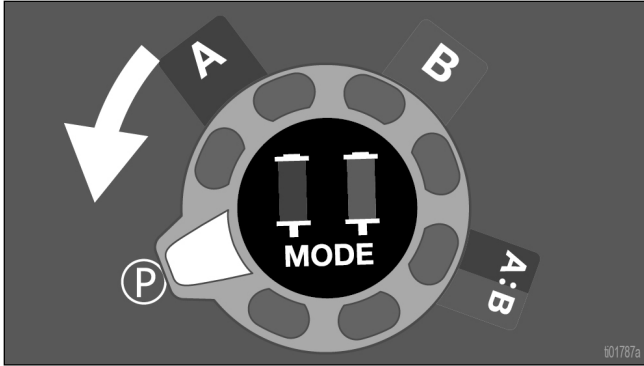

**NOTE:** Parking the pumps prevents moisture from curing material on pump rods, extending the life of the pump seals.

**NOTE:** Parking the pumps is required for convenient removal of ProConnect Swappable Pumping System.

# Remove ProConnect Swappable Pumping System

To remove the ProConnect Swappable Pumping System, follow the following steps:

1. Return the pumps to the park position and turn the ON/OFF switch to **OFF**.
2. Pull the Pump Tilt Release outward and lift the ProConnect Handle to pivot the two pumps upwards.

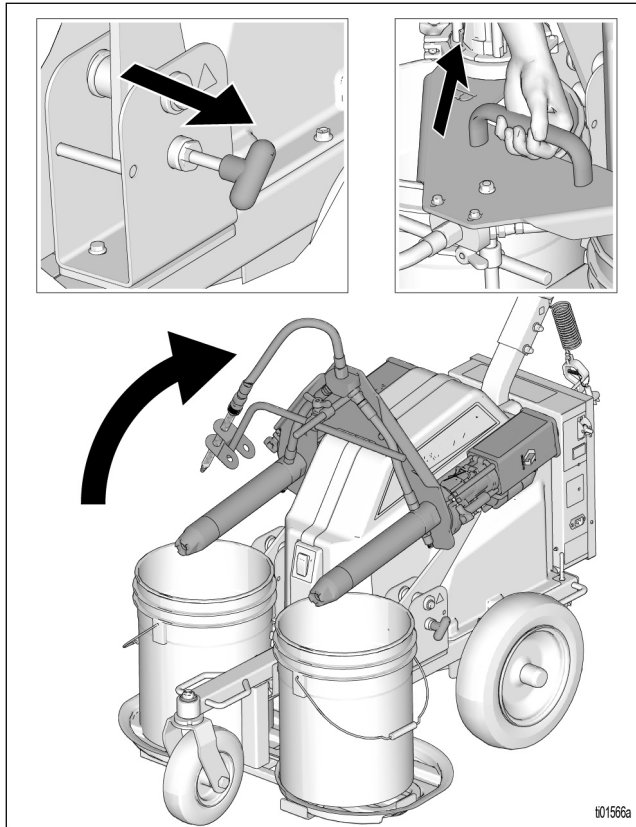

3. Release the ProConnect Clamps and pressure transducer cables.

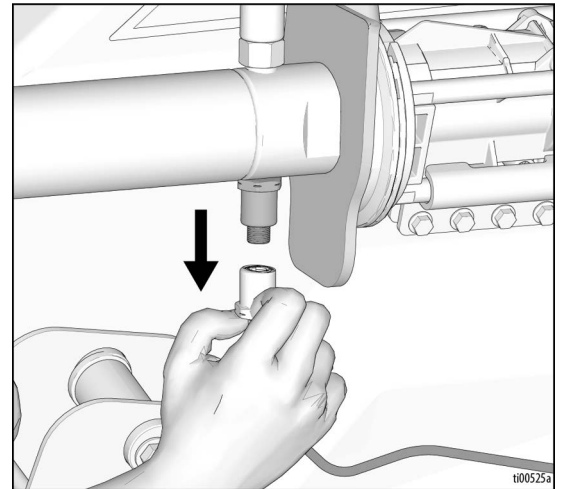
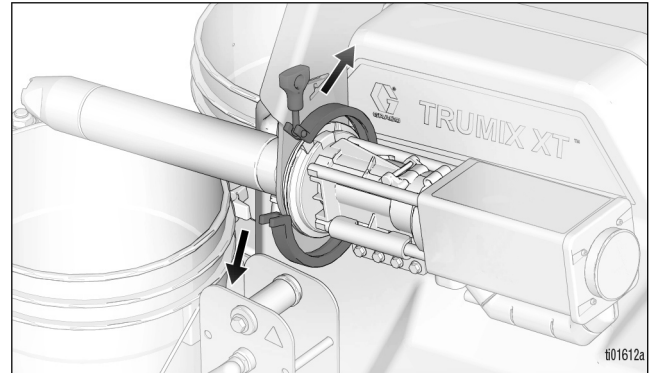

4. Remove the ProConnect Swappable Pumping System.

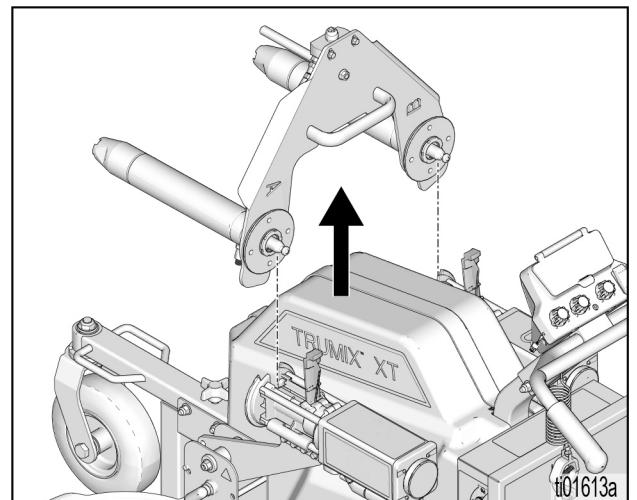

# Replace ProConnect Swappable Pumping System

To replace the ProConnect Swappable Pumping System, follow the following steps:

1. Mark sure the motor drivers are in the upward pivot position.

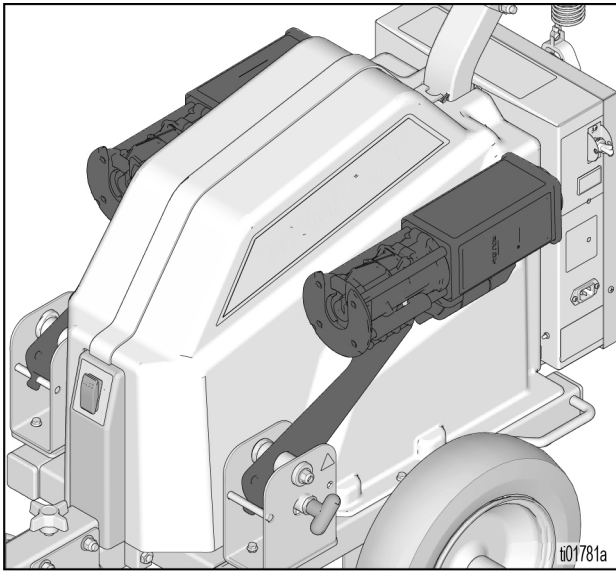

2. Lift driver doors.

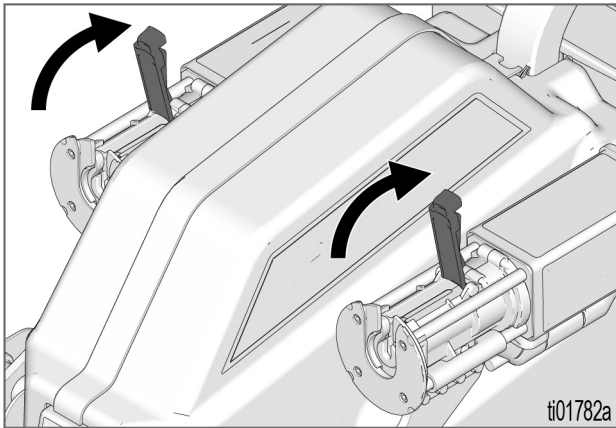

3. Ensure top of pump rod is adjusted to 5/8 in. (1.59 cm) +/- 1/8 in. (0.32 cm) for proper fit in driver.

**NOTE:** If necessary, use a screwdriver to gently pry out and tap back the pump rod to the required 5/8 in. (1.59 cm) adjustment.

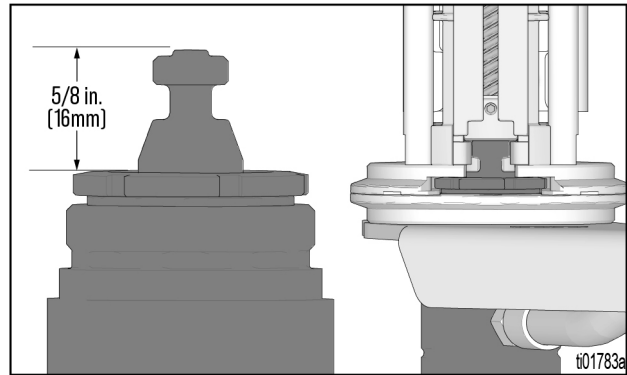

4. Slide the ProConnect Swappable Pumping System into place.

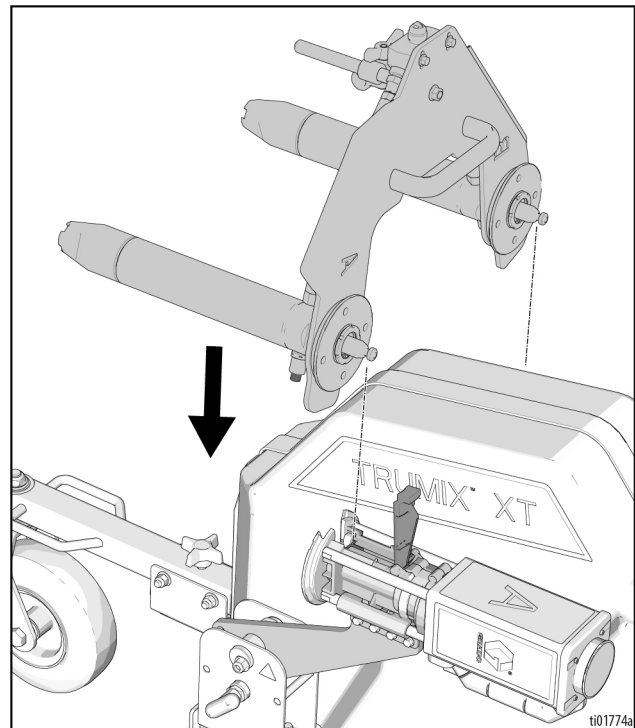



5. Lower Driver Doors.

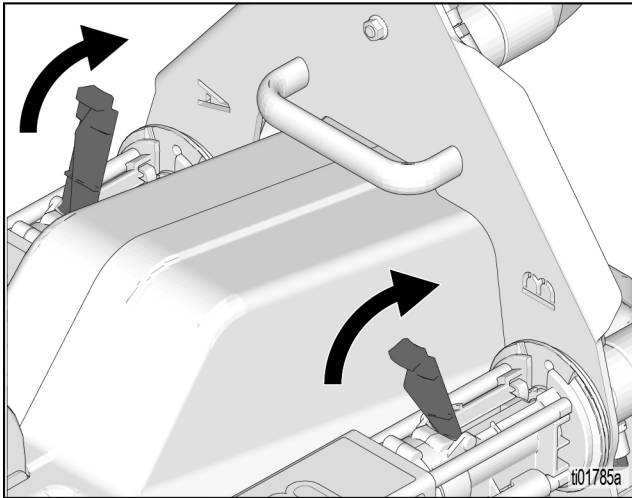

6. Lock the ProConnect Clamps into place and reconnect pressure transducer cables. Use an adjustable wrench to tighten clamps one turn past hand tight.

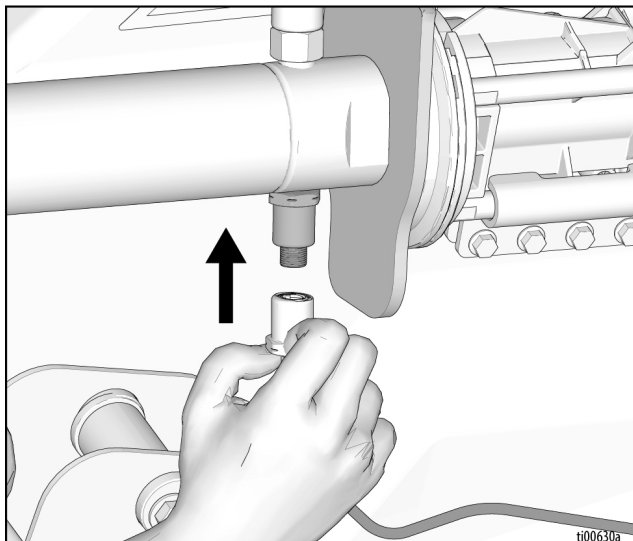
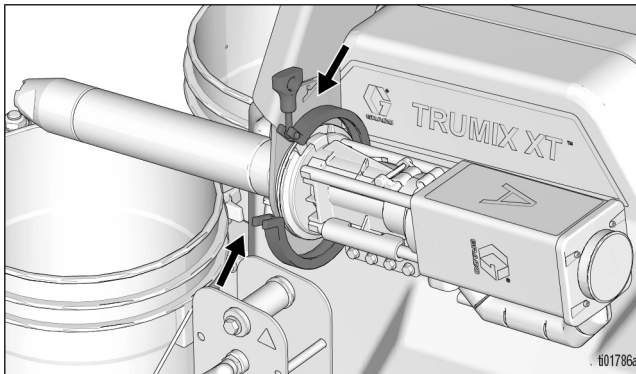

7. Using the ProConnect Handle, pivot the two pumps into the downward position and lock into place with the Pump Tilt Release.

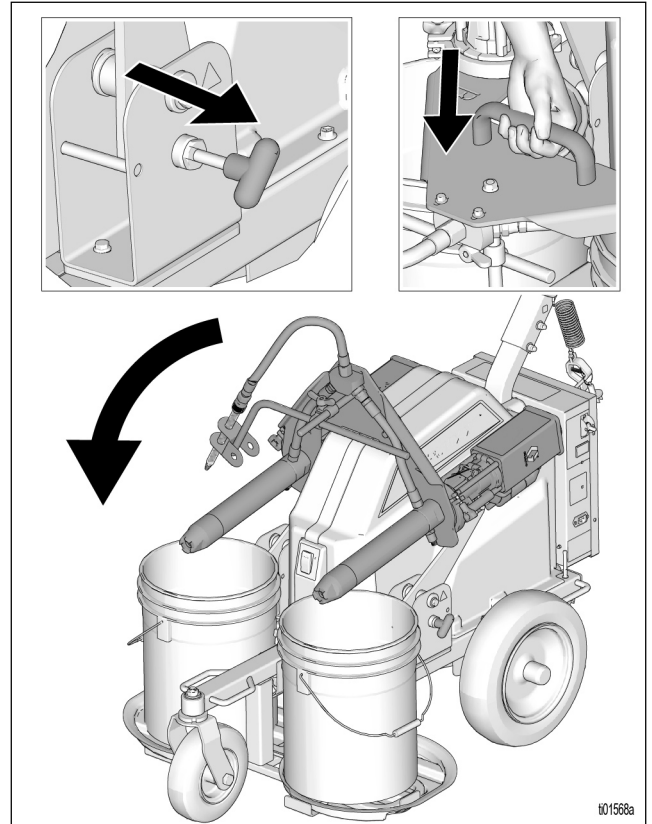

# Storage

1. Flush the system, see **Flush the TruMix XT**, page 28.
2. Place the applicator into a waste pail and move the Pump Mode Knob to the park position. Turn Material Dispense Switch **ON**.

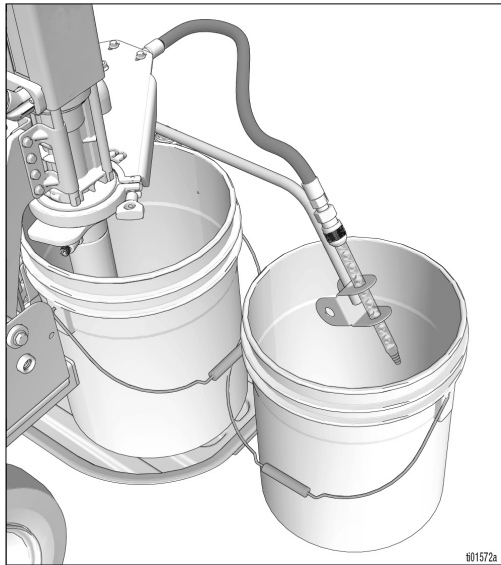

3. Pull the Pump Tilt Release handle outward and lift the ProConnect Handle to pivot the pumps up and out of the pails.

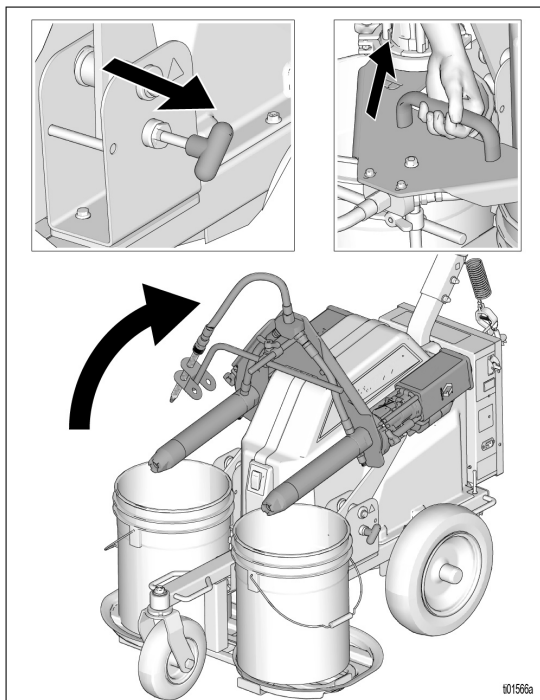

4. Use a clean towel to wipe down the outside of each pump. Use a separate towel for each pump.

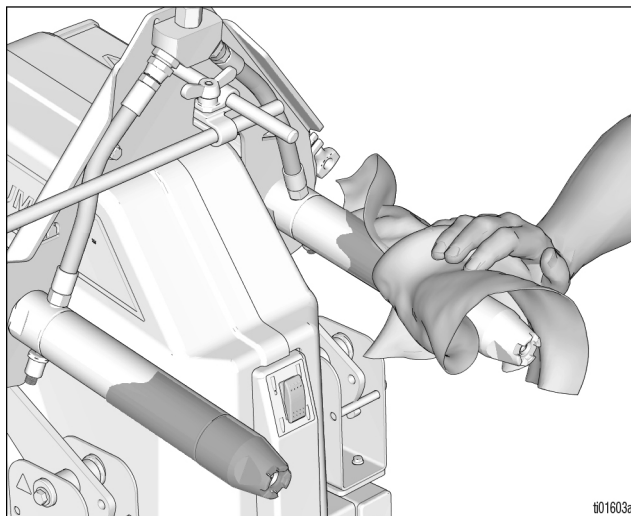

**NOTICE**

It is vital to use a separate, clean rag for each pump. Using the same rag to clean both the A and B pumps might activate the two-component mixtures and result in material curing on the pumps, resulting in potential damage.

5. Remove used pails from the Removable Bucket Holder and replace with clean pails to catch any leaks while the system is stationary.

**NOTE:** Moisture sensitive materials may require removal of pump inlet valve to clean residual material prior to storage. See, **Cleaning**, page 36.

6. Pull the Pump Tilt Release outward and pivot the pumps downward into the clean pails.

**NOTE:** Storing the ProConnect Swappable Pumping System in the vertical down position minimizes risk of clogging of Dispense Manifold.

7. Turn ON/OFF Switch to **OFF** to power down the system. Charge the battery overnight, see **Charge the Battery**, page 18.

# Maintenance

Routine maintenance is important to ensure proper operation of your system. Maintenance includes performing routine actions which keep your system in operation and prevents trouble in the future.



## Preventative Maintenance Schedule

Activity	Interval
System Verification - Run Ratio Check	Daily, start of job, or at sign of any pumping issues
Flush Procedure	Any switch of compatible materials, end of job
Replace CrossLink Multi-Stage Mix Hose	Per material working time
Inspect Dispense Manifold	Each time CrossLink Multi-Stage Mix Hose is replaced
Inspect/Clean Dispense Manifold Check Valves	As required, see <b>Cleaning</b> , page 36
Inspect /Clean Pumps	As required, see <b>Cleaning</b> , page 36
Inspect/Clean Machine	Daily, or each time used, see <b>Cleaning</b> , page 36
Check Hoses for Wear or Damage	Daily, or each time used
ProConnect Clamps Tight	Daily, or each time used

# Cleaning

## Dispense Manifold with Check Valves

1. Follow the **Pressure Relief Procedure**, page 15.
2. Remove Hose Swivel Fitting (A) from the Check Valve Housing (2).
3. Remove Check Valve Housing (2) from the Dispense Manifold (1).
4. Remove Ball (3) and Spring (4) from the Dispense Manifold (1).
5. Inspect and clean Check Valve Housing (2), Ball (3), Spring (4), and Dispense Manifold (1).
6. Remove Crosslink Multi-Stage Mix Hose (5) from Dispense Manifold (1). Clean Dispense Manifold B and A ports.

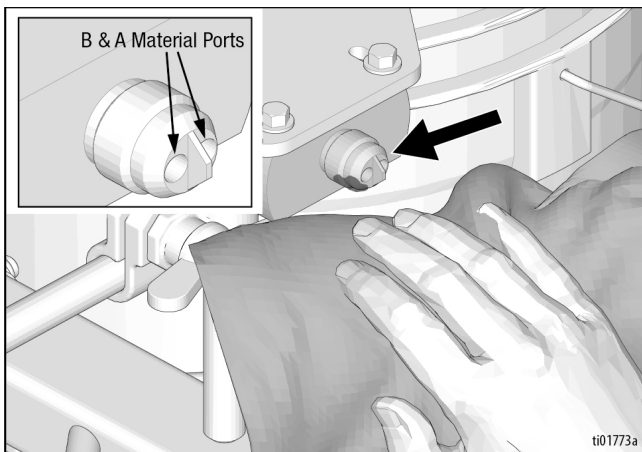

11. Tighten swivel Hose Swivel Fitting (A) to the Check Valve Housing (2).

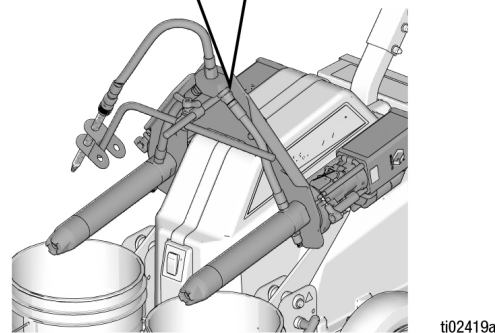
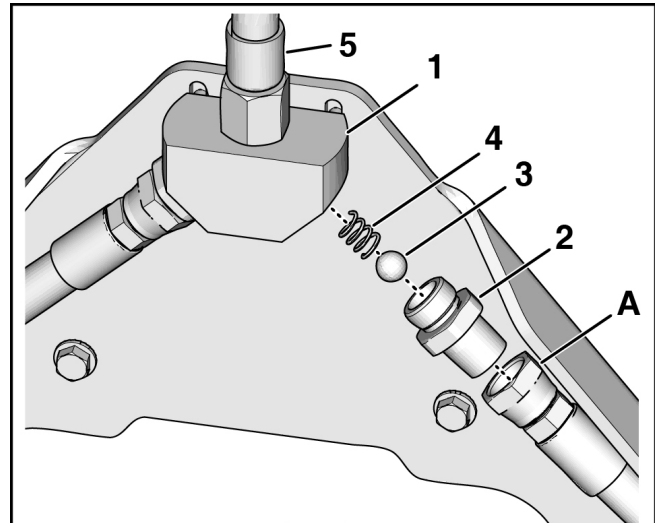

12. Repeat process for the other side.

7. Inspect Crosslink Multi-Stage Mix Hose and replace if there is any sign of material build-up inside.
8. Install Crosslink Multi-Stage Mix Hose to Dispense Manifold (1).
9. Install Spring (4), Ball (3), and Check Valve Housing (2) into Dispense Manifold (1).
10. Torque Check Valve Housing (2) to 25 +/- 2 ft-lbs. (33.9 +/- 2.7 N•m).

## Pump Inlet Valve

1. Unscrew inlet valve from cylinder.

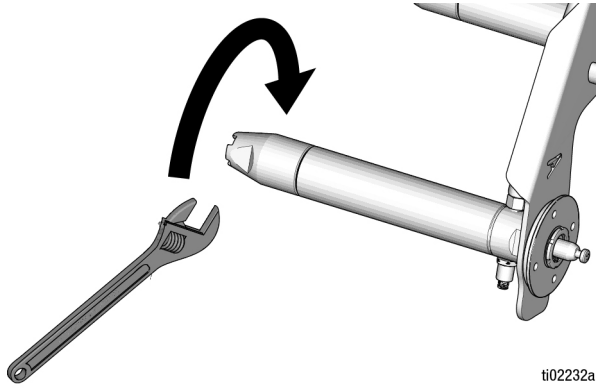

2. Disassemble inlet valve. Clean and inspect parts.

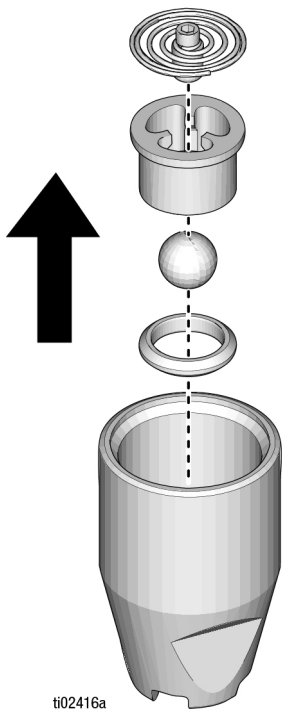

3. Reassemble inlet valve with seat, ball, ball cage and spring. Seat may be flipped over and used on other side. Clean seat thoroughly.

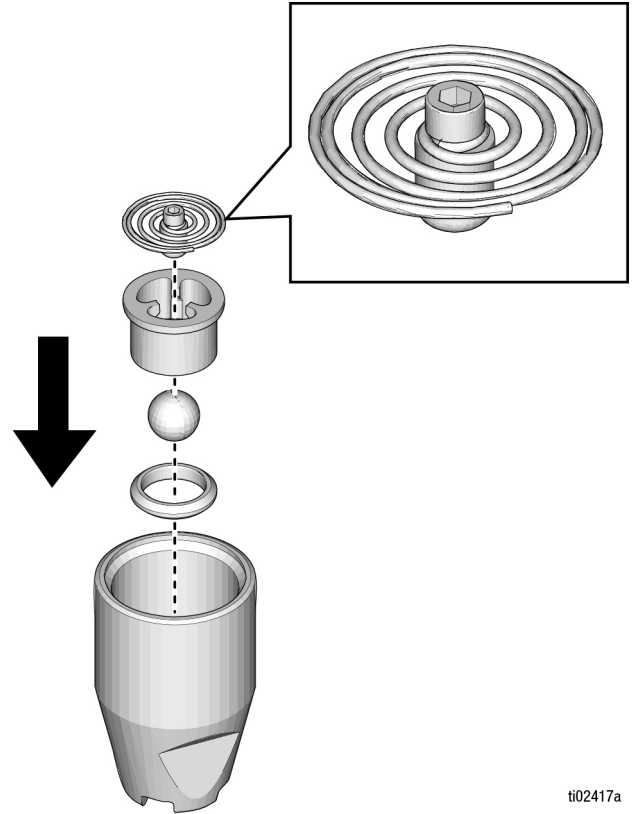

4. Install inlet valve on cylinder and torque to 80 ft-lbs. +/- 5 ft-lbs. (108/5 +/- 6.8 N•m).

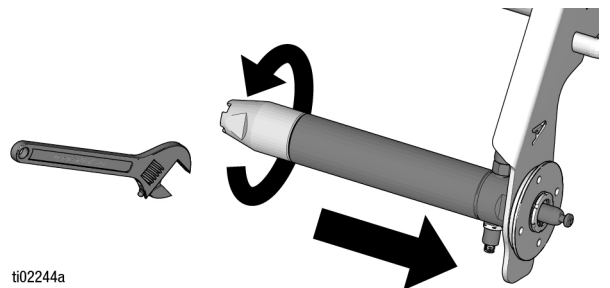

# Troubleshooting

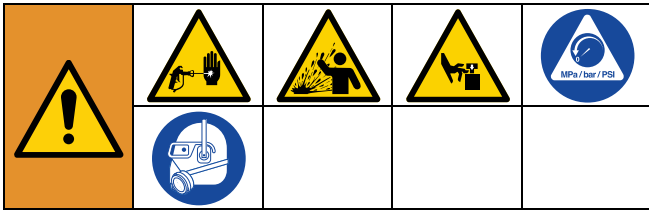

Follow **Pressure Relief Procedure**, page 15, before checking or repairing the equipment.

**NOTE:** Check all possible problems and causes before disassembling the equipment.

Problem	Cause	Solution
Machine does not turn ON	No Power	Turn ON/OFF Switch On.
		Plug in power cord.
		Check incoming power (wall power). Check extension cord, check GFI, check breaker.
		See <b>System Does Not Have Power</b> , page 42.
Machine has power but will not dispense	System issue	See <b>System Does Not Run</b> , page 41.
Inverter AC output voltage is low and the inverter turns loads OFF in a short time	Low battery	Check the condition of the battery and recharge if possible.
	Other battery issue	See <b>System Does Not Run</b> , page 41.
Charger is inoperative and unit will not accept AC	AC voltage has dropped out of tolerance	Check the power supply for proper voltage and frequency.
Charger is charging at a lower rate	Charger controls are improperly set	Use charger setting #2 on inverter.
	Low AC input voltage	Source qualified AC power.
	Loose battery or AC input connections	Check all DC and AC connections.
No Display	ON/OFF switch OFF	Turn ON/OFF switch ON.
	Loose display cable	Check cable connections.
	Display board failed	Check display and replace as necessary.
Display Errors	System alarms	See <b>Display Error Codes</b> , page 45.

Problem	Cause	Solution
Low Output Flow	Thick material	Condition material to recommended temperature per manufacturer specifications.
	CrossLink Multi-Stage Mix Hose clogged	Replace CrossLink Multi-Stage Mix Hose.
	Batch Volume Knob in Ratio Check position	Flow rate limited in Ratio Check setting; use volume or continuous setting.
	Motor Encoder wire connections loose	Check Motor Encoder wire connections.
	Check valves clogged or assembled incorrect	Clean or replace components.
	Material Curing in Dispense Manifold	Clean or replace components, flush with more solvent after future uses, store with pumps vertical.
	Worn piston valve or intake valve inside pump	Rebuild Pump.
Machine stops dispensing before Batch completed without error	Pump Mode Knob and/or Batch Volume Knob changed positions while dispensing	Don't change knob settings during dispense. No issues and proceed with next dispense.
	Knobs incorrectly calibrated	Perform Knob Calibration, see Menu Button, step 11 in <b>System Menu Details</b> , page 47.
Machine not dispensing material during Prime.	Thick material	Condition material to recommended temperature per manufacturer specifications.
	Contamination inside Pumps	Clean Pump.
	Intake valve is leaking	Clean or rebuild Pump.
	Pump seals are worn	Rebuild Pump.
	Dispense Switch not working	Check Dispense Switch wiring & connections; replace switch.
Dispense Manifold leaks	Fittings loose	Clean or replace; re torque connection.
	Seals worn	Replace Check Valve Housing O-ring.
A/B Component Material Hose leaks	Fittings loose	Loosen hose swivel connection to Dispense Manifold, tighten NPT hose connection to Pump Outlet, and re-tighten hose swivel connection to Dispense Manifold.
Pump Leaks	Worn seals	Rebuild Pump.
Pumps don't pivot up/down	Pump Tilt Release interference	Relieve tension on ProConnect Handle by lifting assembly then pull Pump Tilt Release.
		Adjust Motor height for proper Pump Tilt Release engagement.
Transducer contacting bucket	Too tall of bucket (>15 inches; >0.38 meters)	Use buckets <15 inches (<0.38 meters).
	Motor height moved	Adjust motor height accordingly.

Troubleshooting

<b>Problem</b>	<b>Cause</b>	<b>Solution</b>
ProConnect Swappable Pumping System does not remove	Pump Rod interfering with Motor Housing	Park Pumps.
	Transducer cables connected to ProConnect Swappable Pumping System	Remove both transducer cables from transducers.
ProConnect Swappable Pumping System does not install	Pump Rod interfering with Precision Drive	Park Pumps and/or adjust Pump Rod height.
	Pump Rod interfering with Motor Housing	Adjust Pump Rod height.
	Motor spacing incorrect (height or width)	Adjust Motor height or Motor Base width accordingly.
Transducer cables do not connect to transducers	Transducers have a key slot alignment feature that mates to the transducer cable	Turn transducer cable until key slot aligns.
Brake does not engage / disengage	Low tire air pressure	Add air pressure to the tire.
	Tires worn	Set bracket to next engagement position.
Brake produces a high pitch noise when engaging / disengaging	Lack of Grease on Brake components	Grease Brake Arm contact points.
Application arm does not swing, swivel, or adjust.	Incorrect Clamp tension	Adjust Clamp tension accordingly.
	Material cured on Clamp	Replace Clamp.
CrossLink Multi-Stage Mix Hose kinks when swiveling from one side of machine to other	Arm not extended far enough out	Extend arm fully outward in clamp and tension accordingly.
Bucket bracket does not remove / install	Interference with front tire	Rotate front tire 90 to 180 degrees.
	Interference with hand knob	Back off hand knob a few turns.
	Hand knob does not turn	Replace Bucket Bracket Assembly.
Bucket Bracket does not support material weight	Hand knob loose	Tighten hand knob.
	Hand knob does not turn	Replace Bucket Bracket Assembly.
Front caster does not swivel	Material cured in Caster assembly	Clean and/or replace front Caster assembly.
Front tire does not spin freely	Axel nuts too tight	Loosen Axel nuts 1/4 to 1/2 turn.
	Material cured in Axel assembly	Clean and/or replace front Axel assembly.
Rears tires do not spin freely or sequel	Axel nuts too tight	Loosen Axel nuts 1/4 to 1/2 turn.



# System Does Not Run

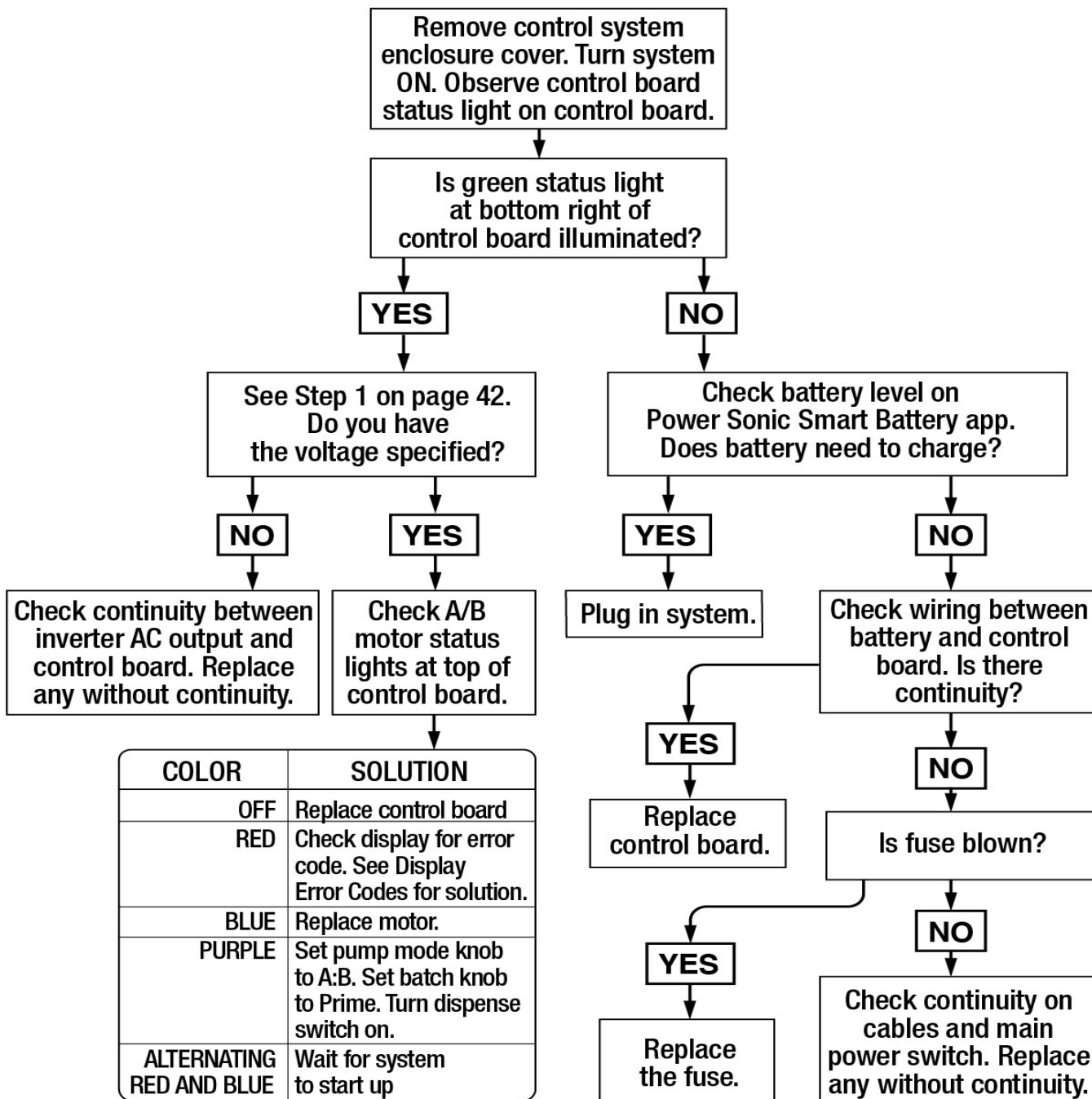

ti01861a

## System Does Not Have Power

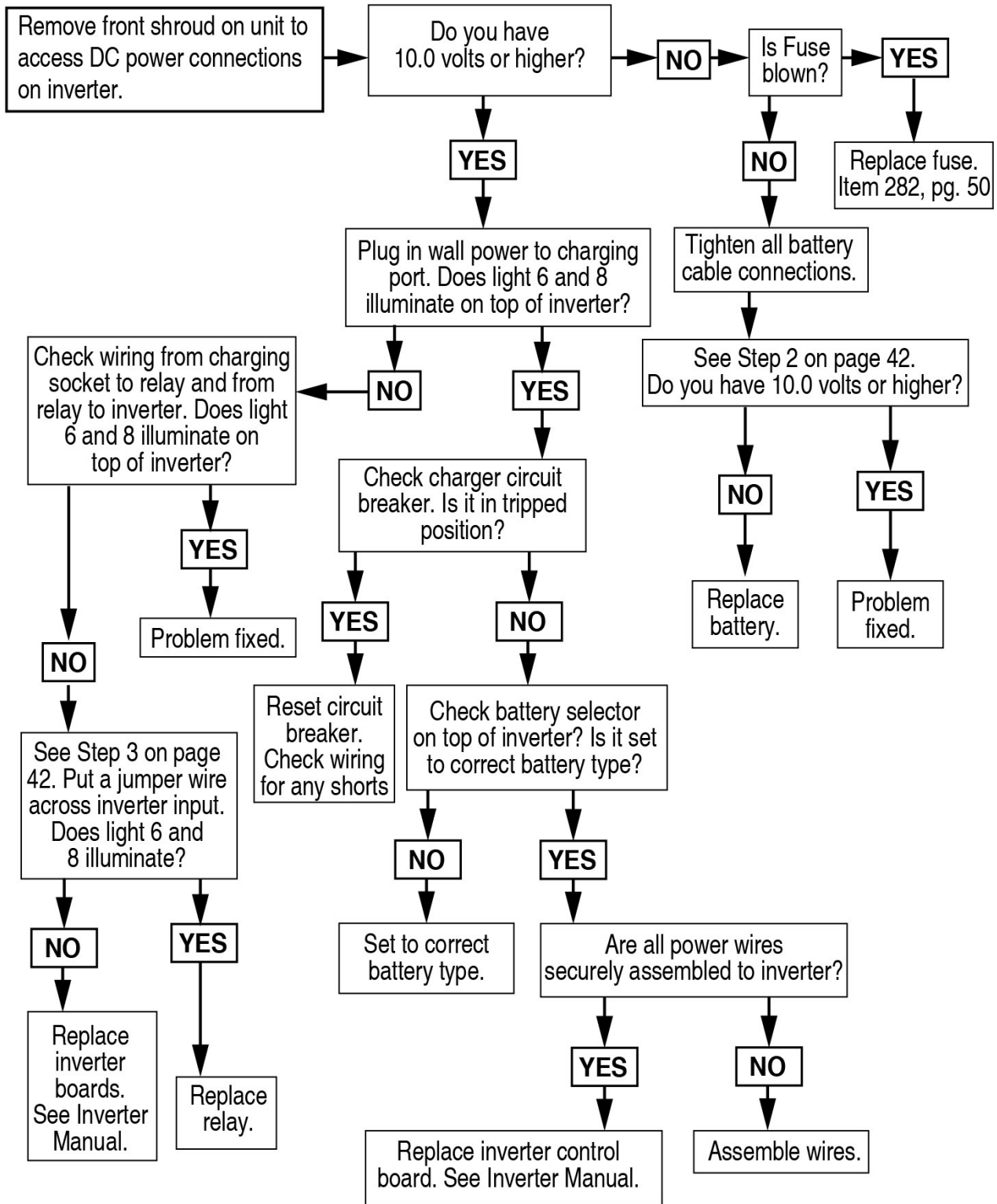

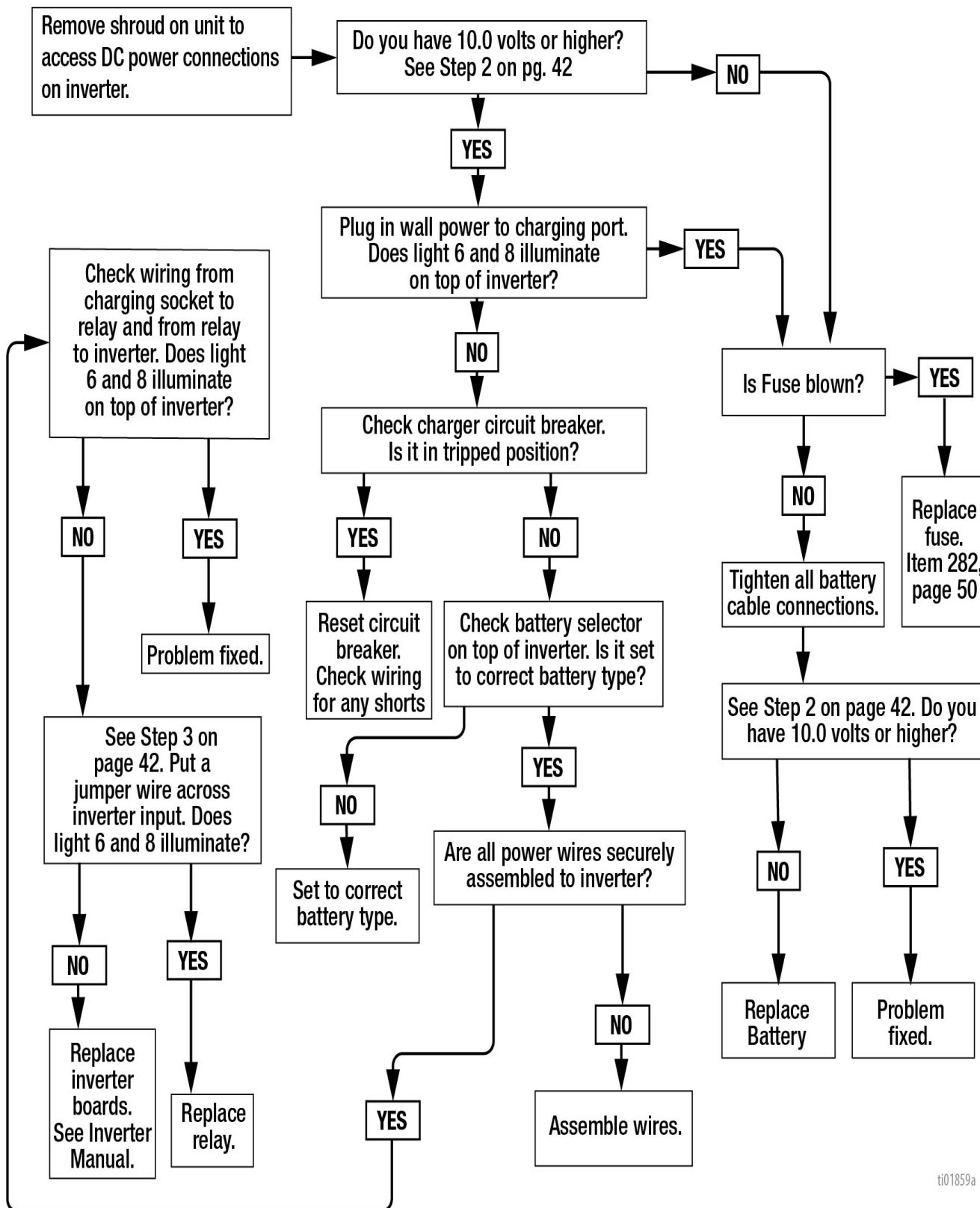

ti01858a

# Battery Will Not Charge



ti01859a

## Check Voltage

				
<p>To reduce the risk of injury from electric shock, do not touch components in the control enclosure while power is on. Wait five minutes after disconnecting power cord before servicing.</p>				

Some troubleshooting steps require checking the voltage of the TruMix XT. If directed to check the voltage, follow one or more of the steps listed here.

**Step 1. Plug Power cord in and turn switch ON. Connect probes to control board. Turn meter to DC volts.**

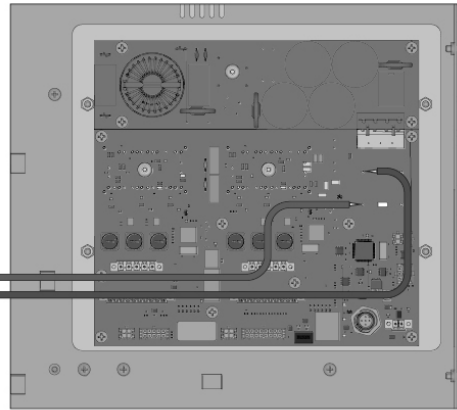
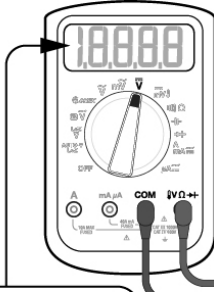

Model 2003102 - 150-190 VDC  
Model 2003103 - 290-360 VDC

**Step 2. Connect probes to positive and negative posts on inverter.**

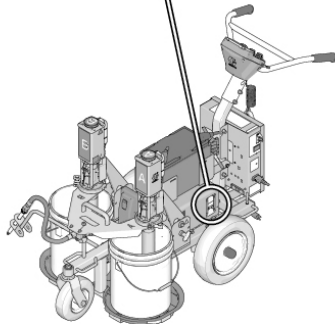
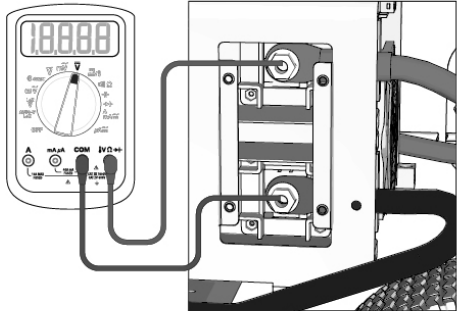

**Step 3. Connect jumper across pins 1 and 2.**

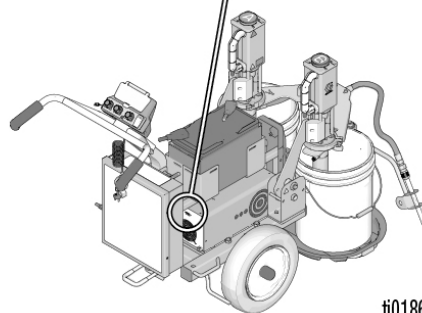
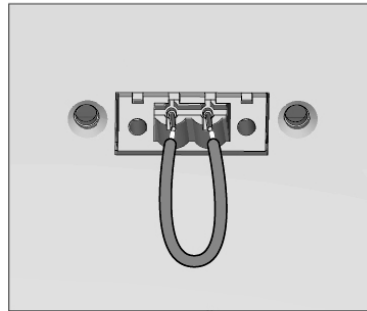

t01860a

# Display Error Codes

If any error codes are active, the lowest numbered error code will scroll across the display until the error is cleared.

**NOTE:** Errors can be cleared by placing the Dispense Switch in the **OFF** position (errors will only clear if the error condition is resolved).

**NOTE:** The system will not operate while any errors are present. A prime is required after all error conditions are resolved before the system will be allowed to dispense on ratio again.

Error Code	Error Description (on Display)	Causes	Solution
E01X	SENSOR FAULT	Short/fault in pressure transducer or motor encoder wiring.	Check motor encoder wiring. Check pressure transducer wiring.
E02A	HIGH PRESSURE DETECTED, PUMP A	Too much restriction on pump A.	Follow <b>Pressure Relief Procedure</b> , page 15. Replace mix hose. Clean check valve. Clean pump.
E02B	HIGH PRESSURE DETECTED, PUMP B	Too much restriction on pump B.	Follow <b>Pressure Relief Procedure</b> , page 15. Replace mix hose. Clean check valve. Clean pump.
E03A	PRESSURE TRANSDUCER NOT DETECTED PUMP A	Pressure transducer A unplugged. <b>NOTE:</b> This error will not occur while the Pump Mode Knob is set to park.	Check A pressure transducer wiring. Replace A pressure transducer.
E03B	PRESSURE TRANSDUCER NOT DETECTED PUMP B	Pressure transducer B unplugged. <b>NOTE:</b> This error will not occur while the Pump Mode Knob is set to park.	Check B pressure transducer wiring. Replace B pressure transducer.
E04A	HIGH INCOMING VOLTAGE DETECTED	Supply voltage too high.	Check supply voltage, see inverter troubleshooting flow chart.
E04B			
E08A	LOW INCOMING VOLTAGE DETECTED	Supply voltage too low. Battery low.	Charge battery. Check supply voltage. See inverter troubleshooting flow chart.
E08B			
E09A	MOTOR ENCODER FAULT PUMP A	A motor calibration failed. Invalid output from encoder A.	Relieve pressure and recalibrate motors. Check A encoder wiring.
E09B	MOTOR ENCODER FAULT PUMP B	B motor calibration failed. Invalid output from encoder B.	Relieve pressure and recalibrate motors. Check B encoder wiring.
E10A	CONTROL BOARD THERMAL PROTECTION FAILED	Motor controller too hot.	Let motor controller cool down. Ensure airflow to the unit is not restricted and system is in allowable temperature range.
E10B			
E12A	EXCESSIVE CURRENT PROTECTION ENABLED PUMP A	Motor current too high.	Call Graco technical assistance.
E12B	EXCESSIVE CURRENT PROTECTION ENABLED PUMP B		
E15A	NO MOTOR CURRENT PUMP A	Motor disconnected.	Check A motor wiring.
E15B	NO MOTOR CURRENT PUMP B		Check B motor wiring.

Display Error Codes

Error Code	Error Description (on Display)	Causes	Solution
E20X	LOW RATIO (B RICH)	Low ratio.	Check A motor and encoder wiring. Replace A precision drive. Replace A motor.
E21X	HIGH RATIO (A RICH)	High ratio.	Check B motor and encoder wiring. Replace B precision drive. Replace B motor.
E23A	MOTOR NOT SPINNING PUMP A	Motor incorrectly calibrated.	Calibrate motors, see step 10 in <b>System Menu Details</b> , page 47. Check A motor and encoder wiring.
E23B	MOTOR NOT SPINNING PUMP B		Calibrate motors, see step 10 in <b>System Menu Details</b> , page 47. Check B motor and encoder wiring
E24A	INVALID STROKE RANGE PUMP A	Motor and pump not coupled.	Verify that ProConnect Swappable Pumping System is attached properly. Check A encoder wiring. Replace A precision drive.
E24B	INVALID STROKE RANGE PUMP B		Verify that ProConnect Swappable Pumping System is attached properly. Check B encoder wiring. Replace B precision drive.
E25X E26X	CONTROL BOARD COMMUNICATION FAULT	Control board not working.	Replace control board.
E27X	CONTROL BOARD SOFTWARE MISMATCH	Wrong hot software loaded onto control board.	
E28X	MODE KNOB NOT DETECTED	Pump Mode Knob unplugged or shorted. <b>NOTE:</b> This error can be acknowledged by pressing either button on the display so that the knobs can be calibrated.	Calibrate knobs, see step 11 in <b>System Menu Details</b> , page 47. Check wiring.
E29X	BATCH KNOB NOT DETECTED	Batch Volume Knob unplugged or shorted. <b>NOTE:</b> This error can be acknowledged by pressing either button on the display so that the knobs can be calibrated.	
E30X	SPEED KNOB NOT DETECTED	Flow Speed Knob unplugged or shorted. <b>NOTE:</b> This error can be acknowledged by pressing either button on the display so that the knobs can be calibrated. <b>NOTE:</b> This error will not occur while the batch volume knob is set to Ratio Check.	
E31A	LOW PRESSURE DETECTED PUMP A	Too little restriction on pump A.	Ensure mix hose is attached to system. Check pump and hoses for leaks. Ensure chemical is compatible with system.
E31B	LOW PRESSURE DETECTED PUMP B	Too little restriction on pump B.	
E32A E32B	PUMP BLOCKAGE/LEAK DETECTED	Leak or blockage in pump A. Leak or blockage in pump B.	Refill material. Check material for air entrapment or foreign debris. Check/clean pump balls, seals, and seats.
E99A	FEED ERROR PUMP A	Pump A cavitating or out of material, or inlet pump ball stuck.	
E99B	FEED ERROR PUMP B	Pump B cavitating or out of material, or inlet pump ball stuck.	

# System Menu Details

See *Digital Display, page 13*, for menu controls.

Ref.	Name	Description
A	System Information Screen	This screen displays current material ratios, error codes, and other system information.
B & C	Menu Button (4 Primary Menu Positions and 12 Secondary Menu Positions)	<p><b>Primary Menu</b></p> <p><b>NOTE:</b> Within the primary menu, the display will return to "1-RATIO" after five seconds of display inactivity.</p> <p><b>1 - Ratio</b></p> <p>Indicates the mode, depending on mode dial position (listed below).</p> <ul style="list-style-type: none"> <li>• <b>Park:</b> Park mode</li> <li>• <b>A:</b> A only</li> <li>• <b>B:</b> B only</li> <li>• <b>A:B:</b> Cycles between "A#,## and B#,##" indicating the current ratio target. User can double press to edit A (ratio numerator) or use individual presses or holds to increase or decrease the value. Once A (ratio numerator) is at the desired value, double press to advance to B (ratio denominator). Once B (ratio denominator) is at the desired value, double press to exit edit mode and accept the new ratio target. See <b>Setup Ratios</b>, page 19.</li> </ul> <p><b>2 - Batch Setting (GAL/L)</b></p> <p>Indicates batch setting depending on Batch Volume Kbob position (listed below).</p> <ul style="list-style-type: none"> <li>• <b>Prime:</b> Prime</li> </ul> <p><b>NOTE:</b> Volume dispensed in prime setting ranges from 1.2L to 3.7 L, depending on ratio set by user.</p> <ul style="list-style-type: none"> <li>• <b>Ratio Check:</b> Ratio check</li> <li>• <b>0.5 Gallon Batch:</b> 0.50 / 2 liter batch - 2.00</li> <li>• <b>1 Gallon Batch:</b> 1.00 / 4 liter batch - 4.00</li> <li>• <b>2 Gallon Batch:</b> 2.00 / 8 liter batch - 8.00</li> <li>• <b>3 Gallon Batch:</b> 3.00 / 12 liter batch - 12.00</li> <li>• <b>Custom Batch:</b> Displays custom batch volume in user units (gal/L). Double press to edit the volume using individual button presses or holds to increase or decrease the value.</li> <li>• <b>Continuous:</b> Continuous</li> </ul> <p><b>3 - Job A</b></p> <p>Displays A material dispensed since totalizer was reset. Double press to be prompted to reset volume totalizer.</p> <p><b>NOTE:</b> Resetting the A totalizer with also reset the B totalizer.</p> <p><b>NOTE:</b> Material dispensed during a ratio check is not included in the totalizer.</p> <p><b>4 - Job B</b></p> <p>Displays B material dispensed since totalizer was reset. Double press to be prompted to reset volume totalizer.</p> <p><b>NOTE:</b> Resetting the B totalizer with also reset the A totalizer.</p> <p><b>NOTE:</b> Material dispensed during a ratio check is not included in the totalizer.</p>

Ref.	Name	Description
B & C	Menu Button (4 Primary Menu Positions and 12 Secondary Menu Positions)	<p><b>Secondary Menu</b></p> <p><b>5 - Volume Units</b> Displays the user volume units. Double press to edit. <b>NOTE:</b> Volume units are used to infer pressure units. Volume units of “GAL” will lead to pressure units of “psi”. Volume units of “L” will lead to pressure units of “bar”.</p> <p><b>6 - Pressure A</b> Displays pressure transducer reading at the outlet of pump A.</p> <p><b>7 - Pressure B</b> Displays pressure transducer reading at the outlet of pump B.</p> <p><b>8 - Life A</b> Displays A material dispensed over the lifetime of the motor controller (system).</p> <p><b>9 - Life B</b> Displays B material dispensed over the lifetime of the motor controller (system).</p> <p><b>10 - Motor Calibration (can only be performed during service)</b> <b>NOTE:</b> Residual fluid in CrossLink Multi-Stage Mix Hose may dispense. Place a bucket under applicator prior to calibration. Double press to be prompted to reset the motor calibration. Press “Y” to accept. Turn Pump Mode Knob to A:B. Turn Batch Volume Knob to prime. Turn Dispense Switch to ON. Motor will now begin calibration.</p> <p><b>11 - Knob Calibration Left</b> Double press to calibrate the knobs. Updates the low end of the scale and adjusts boundaries accordingly. <b>NOTE:</b> In order to perform knob calibration, all knobs must be turned to the left.</p> <p><b>12 - Knob Calibration Right</b> Double press to calibrate the knobs. Updates the high end of the scale and adjusts boundaries accordingly. <b>NOTE:</b> In order to perform knob calibration, all knobs must be turned to the right.</p> <p><b>13 - Job Log</b> Double press to enter and scroll through a log of previous jobs. Data in the log contains:</p> <ul style="list-style-type: none"> <li>• Index</li> <li>• Target Volume</li> <li>• Ratio Target</li> <li>• Ratio measured</li> </ul> <p>Once log is entered via double press, the left (down) and right (up) buttons can be used to scroll through the log. Double press to exit log. <b>NOTE:</b> The job log only updates when the job volume totalizers are reset or when the system dispenses material at a new ratio.</p> <p><b>14 - Error Log</b> Double press to enter and scroll through a log of previous errors. Data in the log contains:</p> <ul style="list-style-type: none"> <li>• Index</li> <li>• Error Code (see, <b>Display Error Codes</b>, page 45).</li> </ul> <p>Once log is entered via double press, the left (down) and right (up) buttons can be used to scroll through the log. Double press to exit log.</p> <p><b>15 - Controller SW Rev</b> Displays the revision of motor controller software.</p> <p><b>16 - Display SW Rev</b> Displays the revision of the display software.</p>



Ref.	Name	Description
D	System Error Indicator Light	When this light is blinking, it indicates that an error has occurred. Read the Screen Information Screen (A) for more information.
E	Pump Mode Knob (Four Positions)	<b>Position 1</b> - Park the Pump (Lower pumps to the bottom position for storage and removal)
		<b>Position 2</b> - Run the A Pump when the Dispense Switch is on until an error occurs or the batch volume is reached.
		<b>Position 3</b> - Run the B Pump when the Dispense Switch is on until an error occurs or the batch volume is reached.
		<b>Position 4</b> - Run the A and B Pumps on ratio when the Dispense Switch is on until an error occurs or the batch volume is reached.
F	Batch Volume Knob (Eight Positions)	<b>Position 1 - Prime:</b> Dispense while the Dispense Switch is on until the individual hoses and hot hose are primed (approximate volumes listed below). This material is not guaranteed to be on ratio and should not be used for the end application. <b>NOTE:</b> Volume dispensed in prime setting ranges from 1.2L to 3.7L, depending on ratio set by user.
		<b>Position 2 - Ratio Check:</b> Dispense while the Dispense Switch is ON until 0.25 gallons or 1 liter have been dispensed. Upon completion, you will be prompted to verify whether the target volume (0.25 gallons or 1 liter) was dispensed. If you select "Y" (correct volume dispensed), the ratio assurance light will illuminate and the material may be used for the end application. If you select "N" (incorrect volume dispensed), the ratio assurance light will not illuminate and the material should NOT be used for the end application.
		<b>Positions 3 - 8 Select Dispense Volume:</b> <ul style="list-style-type: none"> <li>• 1/2 Gallon (2 L)*: Dispense while the Dispense Switch is ON until 0.5 gallons (2L) have been dispensed.</li> <li>• 1 Gallon (4 L)*: Dispense while the Dispense Switch is ON until 1 gallon (4L) has been dispensed.</li> <li>• 2 Gallons (8 L)*: Dispense while the Dispense Switch is ON until 2 gallons (8L) have been dispensed.</li> <li>• 3 Gallons (12 L)*: Dispense while the Dispense Switch is ON until 3 gallons (12L) have been dispensed.</li> <li>• Custom Batch (defaults to 4 gallons (16 L))*: Dispense while the Dispense Switch is ON until the custom batch volume has been dispensed.</li> <li>• Continuous: Dispense indefinitely while the Dispense Switch is ON.</li> </ul>
		Batch volume resets when the Dispense Switch is OFF (if the batch is stopped before the volume is reached, it will restart from 0).
H	Flow Speed Knob	This variable knob increases or decreases the target speed/flow. Turning the knob clockwise makes the system operate faster; turning it counterclockwise makes it operate slower. <b>NOTE:</b> When the Batch Volume Knob is in the ratio check position, material will be dispensed at the minimum speed.
J	Dispense Switch	This switch determines whether the pumps run (ON) or stop (OFF).
O	ON/OFF Switch	This toggle switch controls the overall power for the entire system.
	Serial ID	Identifies the serial number of your particular system.

# Parts

## TruMix XT

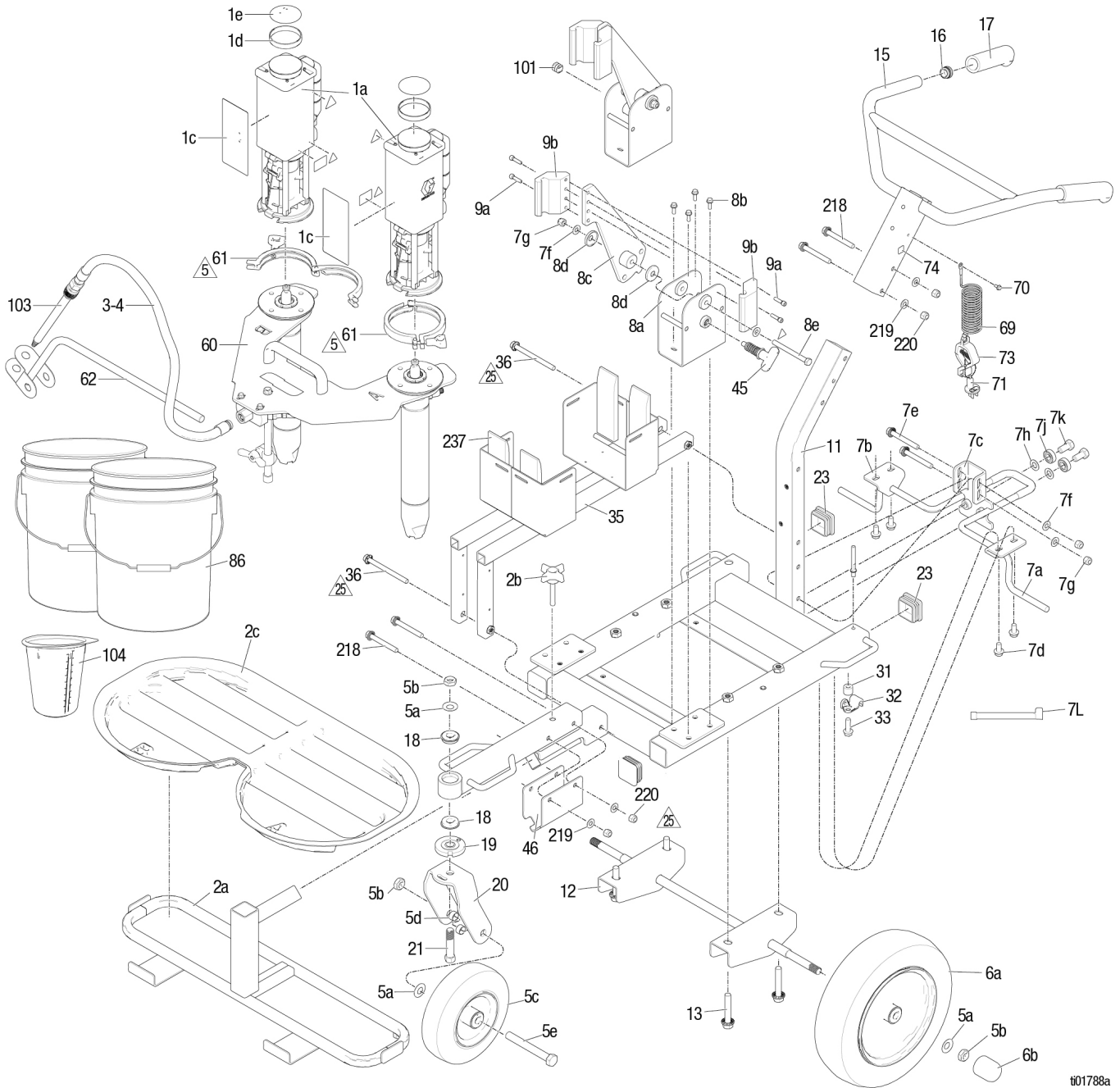

ti01788a

Ref.	Torque
5	Tighten one turn past hand tight
25	Torque to 23-27 ft-lbs. (31-37 N•m)

## TruMix XT Parts List

Ref.	Part	Description	Qty	Ref.	Part	Description	Qty
1*	2005979	KIT, XT Extreme Torque Driver, <i>includes 1a, 1c, 1d, 1e (1 pack)</i>	1	10	2005993	KIT, Spill catch bucket tray kit (2 pack), <i>includes 2c</i>	1
1a	---	DRIVER	1	11	---	FRAME, painted	1
1c	---	LABEL, identification	1	12	24Z605	AXLE, assembly	1
1d	---	BAND	1	13	---	SCREW, hex hd., 1/2-13 x 2.75 in. long	4
1e	---	LABEL, operations	1	15	24Z284	BAR, handle	1
2	2005982	KIT, Removable bucket holder, <i>includes 2a, 2b, 2c</i>	1	16	---	PLUG, tube, 3/4 tube i.d.	2
2a	---	BRACKET, bucket	1	17	114659	GRIP, handle	2
2b	---	KNOB, pronged	1	18	119532	BEARING, flanged	2
2c	---	TRAY, bucket	1	19	15E773	DISK, adjuster	1
3	2004623	KIT, Crosslink multi-stage mix hose (1 pack)	1	20	---	FORK, painted	1
4	2002743	KIT, Crosslink multi-stage mix hose (3 pack), <i>includes 3</i>	1	21	15E780	PIN, fork	1
5	2005983	KIT, Front wheel, <i>includes 5a, 5b, 5c, 5d, 5e (1 pack)</i>	1	23	---	PLUG, tube, 2 in. square	4
5a	---	WASHER, belleville, 5/8 in. fastener	1	31	---	SPACER, nylon, 3/8 i.d., 5/8 o.d., 0.625 in. long	1
5b	---	NUT, lock, nylon insert, 5/8-11	1	32	278204	CLIP, drain line	1
5c	---	WHEEL, small	1	33	---	SCREW, hex hd., flanged, 3/8-16 x 1.25 in. long	1
5d	---	SPACER, wheel	2	35	---	BRACKET, battery	1
5e	---	SCREW, hex hd., 5/8-11 x 5 in. long	1	36	---	SCREW, hex hd., flanged, 3/8-16 x 4.5 in. long	2
6*	2005984	KIT, Rear wheel, <i>includes 6a, 6b, 6c, 6d (1 pack)</i>	1	45	2005990	PLUNGER	1
6a	---	WHEEL	2	46	2006574	KIT, bucket reciever	1
6b	---	CAP, leg	2	60	See pg. 54	KIT, module, fluid, complete, see <b>Fluid Module Kit Parts</b> , page 54	1
7	2005988	KIT, Brake, <i>includes 7a, 7b, 7c, 7d, 7e, 7f, 7g, 7h, 7J, 7K, 7L</i>	1	61	510490	CLAMP	2
7a	---	LEVER, braker	1	62	2005992	KIT, dispense, arm	1
7b	---	BRACKET, pivot	2	69	237686	WIRE, ground assembly	1
7c	---	BRACKET, brake lever	1	70	---	SCREW, thread forming	1
7d	---	SCREW, cap, flange, 0.75 in.	4	71	25U295	KIT, adapter, ground, cordless	1
7e	---	SCREW, hex, flange, 3 in.	2		25U292	ADAPTER, ground plug	1
7f	---	WASHER	2	73	---	TIE, security	1
7g	---	NUT, lock	2	74▲	19D961	LABEL, grounding	1
7h	---	SPACER	2	86	115077	PAIL, plastic	2
7J	---	BEARING	2	101	---	PLUG, snap-in	1
7K	---	SCREW, cap, hex 0.75 in.	2	103	2006324	KIT, mixer (1 pack)	1
7L	---	LUBRICANT, grease, packet	1	104	2003161	KIT, ratio cup with label (25 pack)	1
8*	2005989	KIT, Pump pivot, <i>includes 8a, 8b, 8c, 8d, 8e (1 pack)</i>	2	218	---	SCREW, mach., hex hd., 3/8-16 x 3.0 in. long	8
8a	---	BASE, pump pivot	1	219	---	WASHER, flat, 3/8	8
8b	---	SCREW, hex hd., flanged, 1/4-20 x 0.75 in. long	4	220	---	NUT, lock, 3/8 lb.	8
8c	---	ARM, pump pivot	1	237	25U740	FILLER, plastic, foam	1
8d	---	BEARING, pump tip	2				
8e	---	SCREW, hex hd., 3/8-16 x 4 in. long	1				
9*	2005991	KIT, XT Extreme torque driver mounting block kit, <i>includes 9a, 9b (2 pack)</i>	1				
9a	---	SCREW, cap socket hd., 1/4-20 x 1 in. long	4				
9b	---	BLOCK, driver mounting	2				

▲ Replacement safety labels, tags, and cards are available at no cost.

\* Two kits may be required for complete repair or replacement.

# Enclosure Component Parts

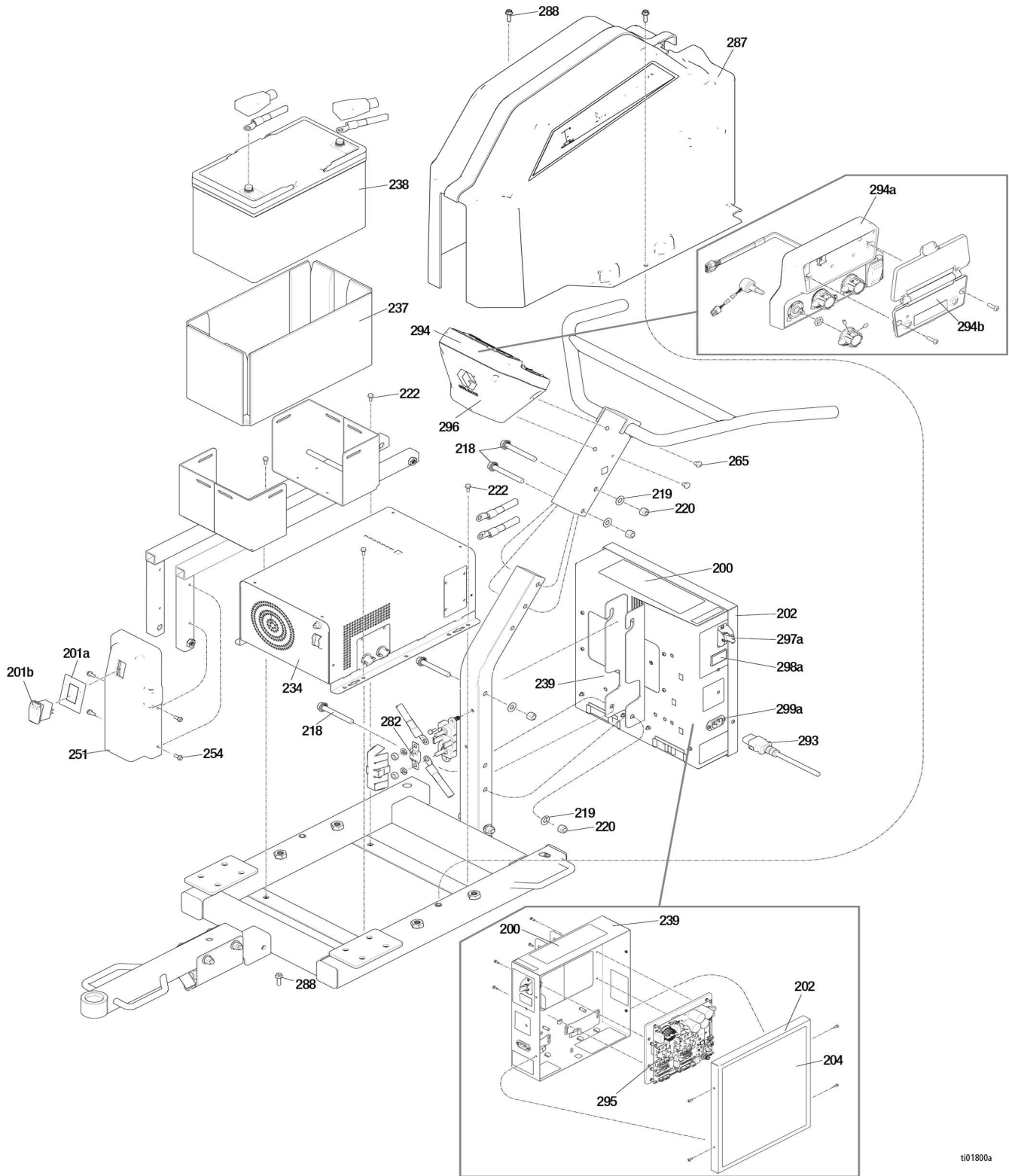

ti01800a

## Enclosure Component Parts List

Ref.	Part	Description	Qty	Ref.	Part	Description	Qty
200▲	2001493	LABEL, Warning	1	287	2007448	KIT, shroud with labels, <i>includes</i> 288	
201	2005994	KIT, Mix station mode dispense switch kit, <i>includes 201a, 201b</i>	1	288	- - -	SCREW, hex hd,	2
201a	- - -	LABEL, dispensing switch	1	293		CORD, power	1
201b	2005994	SWITCH, rocker	1		17N758	120V	
202	- - -	COVER, enclosure	1		24Z800	230V	
204▲	2004684	LABEL, quick guide	1	294	- - -	HMI control	1
218	- - -	SCREW, mach., hex hd., 3/8-16 x 3.0 in. long	8	294a	2005995	HMI, front cover with knobs and display, <i>includes 294b</i>	1
219	- - -	WASHER, flat, 3/8	8	294b	2005996	KIT, HMI display	1
220	- - -	NUT, lock, 3/8 lb.	8	295	2005706	KIT, control, TruMix XT	1
222	- - -	SCREW, mach., hex hd,	4	296	2007449	KIT, HMI rear cover with labels	1
234	- - -	INVERTER/CHARGER	1	297a	131716	SWITCH, on/off	1
	25N794	120V		297b	131717	BOOT, toggle	1
	25N793	230V		297c	107255	GUARD, switch	1
237	25U740	FILLER, plastic, foam	1	297d	119236	SCREW, mach., Torx pan hd.	2
238	25U601	BATTERY, lithium, 12V	1	298a	17N638	METER, volt	1
239	- - -	ENCLOSURE, system control	1	298b	129696	SCREW, pan hd.	2
251	- - -	HOLDER, on/off switch	1	299a	114064	PLUG, inlet	1
254	- - -	SCREW, hex hd., flanged, thread forming, 10-14 x 0.5 in. long	4	299b	15W998	SCREW, mach.	2
265	- - -	SCREW, flat hd., nylon patch, 1/4-20 x 0.5 in. long	2	▲ <i>Replacement safety labels, tags, and cards are available at no cost.</i>			
282	131738	FUSE, 300 amp	1				

# Fluid Module Kit Parts

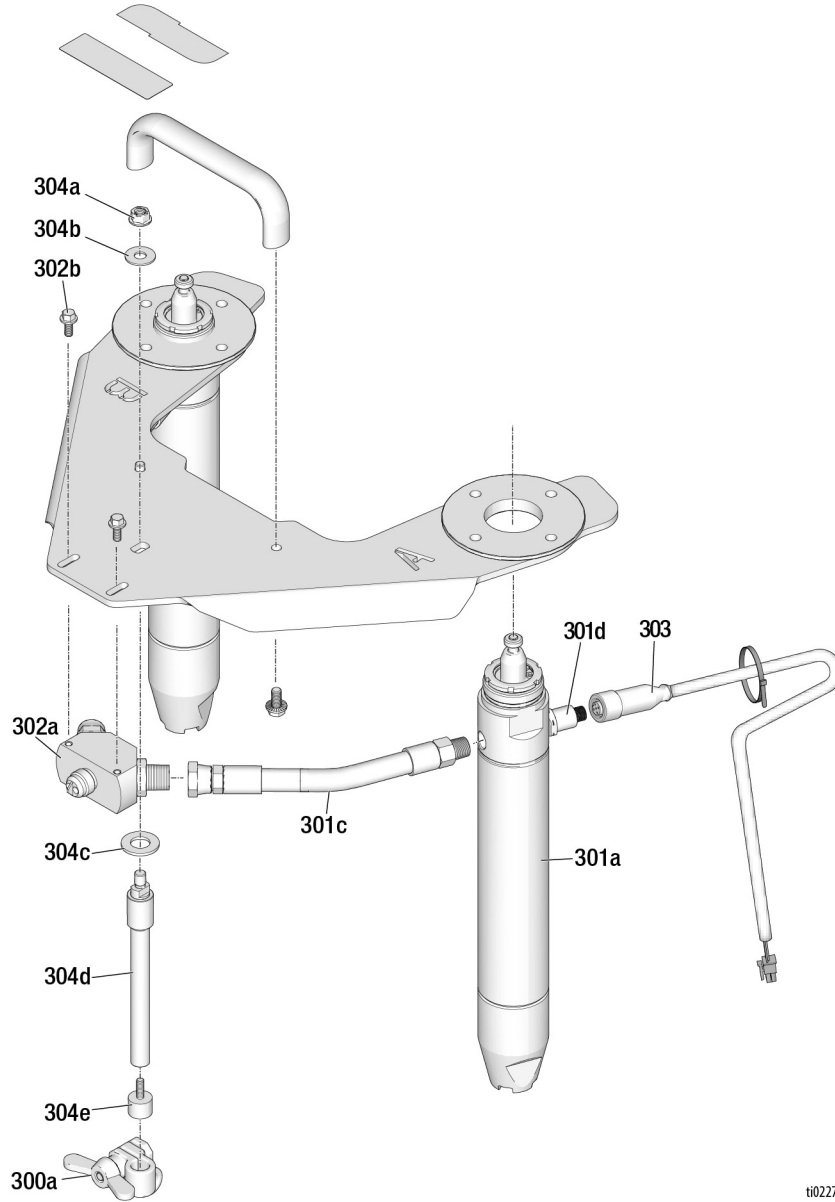

ti02279a

## Fluid Module Kit Parts List

Ref.	Part	Description	Qty
300	2003160	KIT, fluid module, complete, <i>includes 301, 302, 303, 304</i>	1
300a	287566	KIT, clamp	1
301	2005981	KIT, pump lower with hose (1 pack), <i>includes 301a, 301b,</i> <i>301c</i>	1
301a	---	PUMP, lower	1
301c	2006575	KIT, hose, coupled, 11.5 in. (1 pack)	1
301d	18B075PKG	TRANSDUCER, pressure	1
301e	2005980	KIT, pump, repair	1
302	2004987	KIT, dispense manifold, <i>includes</i> <i>302a, 302b</i>	1
302a	---	MANIFOLD, dispense	1
302b	---	BOLT, flange, HD, serrated, 1/4-20 x 5/8 in. long	2
303	2005997	KIT, pressure transducer cable (2 pack)	1
304	2007235	KIT, post, fluid module, <i>includes</i> <i>304a, 304b, 304c, 304d, 304e</i>	1
304a	---	NUT, hex hd., flanged, lock, 3.8 in.	1
304b	---	WASHER, flat, 3/8	1
304c	---	WASHER, flat, 5/8	1
304d	---	POST, fluid module pivot arm	1
304e	---	BUMPER, rubber, threaded	1

# Wiring Diagram

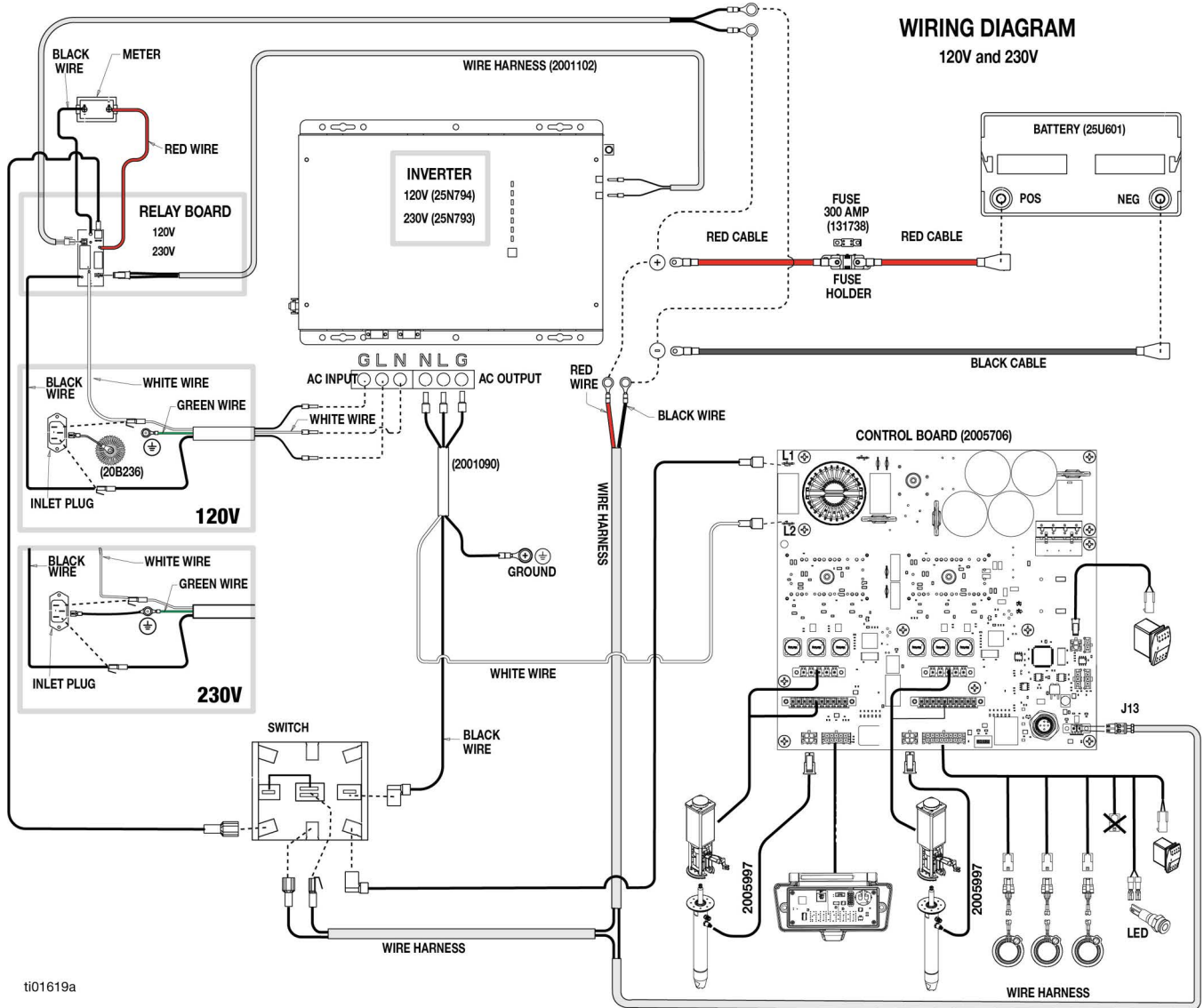

ti01619a



# Technical Specifications

<b>TruMix XT</b>		
	<b>US</b>	<b>Metric</b>
<b>Dimensions</b>		
Height	Unpackaged: 41.25 in. Packaged: 53.0in.	Unpackaged: 104.78 cm Packaged: 134.62 cm
Width	Unpackaged: 31.25 in. Packaged: 39.0 in.	Unpackaged: 79.38 cm Packaged: 99.06 cm
Length	Unpackaged: 72.00 in. Packaged: 75.0 in.	Unpackaged: 182.88 cm Packaged: 190.5 cm
Weight w/ 1 battery (dry - no material)	Unpackaged: 325 lbs. Packaged: 425 lbs.	Unpackaged: 148 kg. Packaged: 193 kg
<b>Output*</b>		
Maximum Delivery (1:1)*	2.0 gpm	7.6 lpm
Maximum Delivery (2:1)*	1.5 gpm	5.7 lpm
Maximum Delivery (4:1)*	1.2 gpm	4.5 lpm
Maximum Working Pressure	600 psi	41.4 bar, 4.14 mPa
<b>DC Input</b>		
Nominal Input Voltage	12.0 Vdc	
Minimum Start Voltage	10.0 Vdc	
Low Battery Alarm	11.0 Vdc	
Low Battery Trip	10.5 Vdc	
High Voltage Alarm and Fault	16.0 Vdc	
High DC Input Recovery	15.5 Vdc	
Lower Battery Voltage Recovery	13.0 Vdc	
Idle Consumption-Search Mode	60W	
<b>Charge**</b>		
Input Voltage Range	100-120 VAC / 200-240 VAC <b>NOTE:</b> Charge current will decrease at low end of voltage range	
Input Frequency Range	50/60 Hz	
<b>Batteries</b>		
Nominal Battery Pack Voltage	12 Vdc	
Type	Lithium (LiFePo4)	
Voltage (Nominal)	12 Vdc	
Dimensions	12.1 in. x 6.6 in. x 8.7 in.	307 mm x 168 mm x 221 mm
Capacity (Nominal, 20hr rate)	100 Amp-hour / battery	
Charging Current	27.1 ADC	
<b>Battery Temperature</b>		
Operating	14-113°F	-10-45°C
Charging	32-113°F	0-45°C
<b>Noise (dBa)</b>		
Maximum sound pressure (ISO 3744)	78.3 dBa	
Maximum sound power (ISO 3744)	89.3 dBa	
<i>Sound pressure measure 3.3 feet (1.0 meter) from equipment.</i>		

<b>TruMix XT</b>		
	<b>US</b>	<b>Metric</b>
<b>Vibration (m/s<sup>2</sup>)</b>		
Right-hand (per ISO 5349)		5.37
Left-hand (per ISO 5349)		6.21
<b>Materials of Construction</b>		
Wetted materials on all models	PTFE, nylon, UHMPWE, acetal, tungsten carbide, stainless steel, chrome plating, nickel-plated carbon steel, ceramic, FKM polypropylene	
<b>Notes</b>		
<p>* Higher ratios and material viscosity will reduce output. Lower temperatures may also reduce output.</p> <p>** If unable to charge battery, or run the system while plugged in, check incoming voltage and frequency.</p> <p>All trademarks or registered trademarks are the property of their respective owners.</p>		

# Recycling and Disposal

This section includes information on how to properly recycle and dispose of a product at the end of its useful life.

## Rechargeable Battery Disposal

Do not place batteries in the trash. Recycle batteries according to local regulations. In the USA and Canada, call 1-800-822-8837 to find recycling locations or go to [www.call2recycle.org](http://www.call2recycle.org).

Do not place batteries in the trash. Recycle batteries according to local regulations.

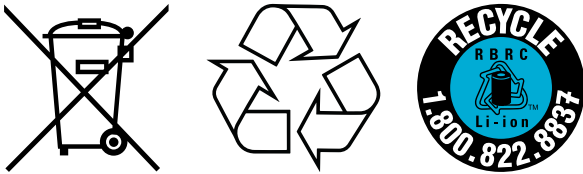

## End of Product Life

At the end of the product's useful life, dismantle and recycle it in a responsible manner.

- Perform the **Pressure Relief Procedure**, page 15.
- Drain and dispose of fluids according to applicable regulations. Refer to the material manufacturer's Safety Data Sheet.
- Remove motors, batteries, circuit boards, LCDs (liquid crystal displays), and other electronic components. Recycle according to applicable regulations.
- Do not dispose of batteries or electronic components with household or commercial waste. 
- Deliver remaining product to a recycling facility.

## California Proposition 65

CALIFORNIA RESIDENTS

 **WARNING:** Cancer and reproductive harm – [www.P65warnings.ca.gov](http://www.P65warnings.ca.gov).

# Graco Standard Warranty

Graco warrants all equipment referenced in this document which is manufactured by Graco and bearing its name to be free from defects in material and workmanship on the date of sale to the original purchaser for use. With the exception of any special, extended, or limited warranty published by Graco, Graco will, for a period of twelve months from the date of sale, repair or replace any part of the equipment determined by Graco to be defective. This warranty applies only when the equipment is installed, operated and maintained in accordance with Graco's written recommendations.

This warranty does not cover, and Graco shall not be liable for general wear and tear, or any malfunction, damage or wear caused by faulty installation, misapplication, abrasion, corrosion, inadequate or improper maintenance, negligence, accident, tampering, or substitution of non-Graco component parts. Nor shall Graco be liable for malfunction, damage or wear caused by the incompatibility of Graco equipment with structures, accessories, equipment or materials not supplied by Graco, or the improper design, manufacture, installation, operation or maintenance of structures, accessories, equipment or materials not supplied by Graco.

This warranty is conditioned upon the prepaid return of the equipment claimed to be defective to an authorized Graco distributor for verification of the claimed defect. If the claimed defect is verified, Graco will repair or replace free of charge any defective parts. The equipment will be returned to the original purchaser transportation prepaid. If inspection of the equipment does not disclose any defect in material or workmanship, repairs will be made at a reasonable charge, which charges may include the costs of parts, labor, and transportation.

**THIS WARRANTY IS EXCLUSIVE, AND IS IN LIEU OF ANY OTHER WARRANTIES, EXPRESS OR IMPLIED, INCLUDING BUT NOT LIMITED TO WARRANTY OF MERCHANTABILITY OR WARRANTY OF FITNESS FOR A PARTICULAR PURPOSE.**

Graco's sole obligation and buyer's sole remedy for any breach of warranty shall be as set forth above. The buyer agrees that no other remedy (including, but not limited to, incidental or consequential damages for lost profits, lost sales, injury to person or property, or any other incidental or consequential loss) shall be available. Any action for breach of warranty must be brought within two (2) years of the date of sale.

**GRACO MAKES NO WARRANTY, AND DISCLAIMS ALL IMPLIED WARRANTIES OF MERCHANTABILITY AND FITNESS FOR A PARTICULAR PURPOSE, IN CONNECTION WITH ACCESSORIES, EQUIPMENT, MATERIALS OR COMPONENTS SOLD BUT NOT MANUFACTURED BY GRACO.** These items sold, but not manufactured by Graco (such as electric motors, switches, hose, etc.), are subject to the warranty, if any, of their manufacturer. Graco will provide purchaser with reasonable assistance in making any claim for breach of these warranties.

In no event will Graco be liable for indirect, incidental, special or consequential damages resulting from Graco supplying equipment hereunder, or the furnishing, performance, or use of any products or other goods sold hereto, whether due to a breach of contract, breach of warranty, the negligence of Graco, or otherwise.

## **FOR GRACO CANADA CUSTOMERS**

The Parties acknowledge that they have required that the present document, as well as all documents, notices and legal proceedings entered into, given or instituted pursuant hereto or relating directly or indirectly hereto, be drawn up in English. Les parties reconnaissent avoir convenu que la rédaction du présente document sera en Anglais, ainsi que tous documents, avis et procédures judiciaires exécutés, donnés ou intentés, à la suite de ou en rapport, directement ou indirectement, avec les procédures concernées.

# Graco Information

For the latest information about Graco products, visit [www.graco.com](http://www.graco.com).

For patent information, see [www.graco.com/patents](http://www.graco.com/patents).

**TO PLACE AN ORDER**, contact your Graco distributor or call 1-800-690-2894 to identify the nearest distributor.

*All written and visual data contained in this document reflects the latest product information available at the time of publication. Graco reserves the right to make changes at any time without notice.*

Original instructions. This manual contains English. MM 3B0119

**Graco Headquarters:** Minneapolis

**International Offices:** Belgium, China, Japan, Korea

**GRACO INC. AND SUBSIDIARIES • P.O. BOX 1441 • MINNEAPOLIS MN 55440-1441 • USA**  
**Copyright 2024, Graco Inc. All Graco manufacturing locations are registered to ISO 9001.**

[www.graco.com](http://www.graco.com)  
Revision B, June 2024