

# MDX Dispense Valve

3A8814F

EN

*Dispense valve for controlling material flow of adhesives, sealants, and other materials that are compatible with the wetted parts of the valve. For professional use only.*

## Model 26D274

3/4 in. npt Dispense Valve

3000 psi (20.68 MPa, 206.8 bar) Maximum Fluid Working Pressure

100 psi (0.7 MPa, 7 bar) Maximum Air Working Pressure



### Important Safety Instructions

Read all warnings and instructions in this manual before using the equipment.  
Save these instructions.

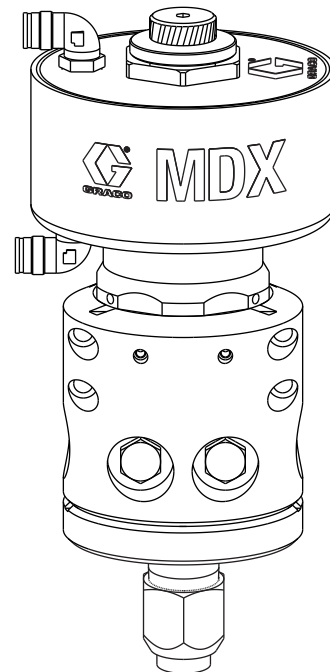













# Contents

<b>Safety Symbols</b> . . . . .	<b>3</b>
<b>General Warnings</b> . . . . .	<b>4</b>
<b>Component Identification</b> . . . . .	<b>6</b>
<b>Theory of Operation</b> . . . . .	<b>7</b>
<b>Installation</b> . . . . .	<b>8</b>
Grounding . . . . .	8
Flush Before Using Equipment . . . . .	8
Mounting . . . . .	8
<b>Operation</b> . . . . .	<b>10</b>
Pressure Relief Procedure . . . . .	10
Adjust Stroke . . . . .	10
Check Ratio . . . . .	10
<b>Maintenance</b> . . . . .	<b>11</b>
Packing Lubrication . . . . .	11
Factors Affecting Valve Life . . . . .	12
<b>Recycling and Disposal</b> . . . . .	<b>13</b>
End of Product Life . . . . .	13
<b>Troubleshooting</b> . . . . .	<b>14</b>
<b>Repair</b> . . . . .	<b>15</b>
Disconnect . . . . .	15
Disassembly . . . . .	16
Assembly . . . . .	17
<b>Parts</b> . . . . .	<b>18</b>
3/4 in. npt Fluid Section . . . . .	18
3/4 in. npt Air Section . . . . .	19
<b>Kits and Accessories</b> . . . . .	<b>20</b>
Grease Gun, 551189 and 2002051 . . . . .	20
Mixer . . . . .	20
Fitting, 122639 . . . . .	20
Ratio Check, 2003978 . . . . .	20
<b>Dimensions</b> . . . . .	<b>21</b>
<b>Technical Specifications</b> . . . . .	<b>22</b>
<b>California Proposition 65</b> . . . . .	<b>23</b>
<b>Graco Standard Warranty</b> . . . . .	<b>24</b>

# Safety Symbols

The following safety symbols appear throughout this manual and on warning labels. Read the table below to understand what each symbol means.

Symbol	Meaning
	Burn Hazard
	Equipment Misuse Hazard
	Fire and Explosion Hazard
	Skin Injection Hazard
	Skin Injection Hazard
	Eliminate Ignition Sources
	Do Not Place Hands or Other Body Parts Near Fluid Outlet

Symbol	Meaning
	Do Not Stop Leaks with Hand, Body, Glove or Rag
	Ground Equipment
	Read Manual
	Follow Pressure Relief Procedure
	Ventilate Work Area
	Wear Personal Protective Equipment







## Safety Alert Symbol

This symbol indicates: Attention! Become Alert! Look for this symbol throughout the manual to indicate important safety messages.

# General Warnings

The following warnings apply throughout this manual. Read, understand, and follow the warnings before using this equipment. Failure to follow these warnings can result in serious injury.

 <h2 style="margin: 0;">WARNING</h2>	
	<p><b>SKIN INJECTION HAZARD</b></p> <p>High-pressure fluid from dispensing device, hose leaks, or ruptured components will pierce skin. This may look like just a cut, but it is a serious injury that can result in amputation. <b>Get immediate surgical treatment.</b></p> <ul style="list-style-type: none"> <li>Do not point dispensing device at anyone or at any part of the body.</li> <li>Do not put your hand over the fluid outlet.</li> <li>Do not stop or deflect leaks with your hand, body, glove, or rag.</li> <li>Follow the <b>Pressure Relief Procedure</b> when you stop dispensing and before cleaning, checking, or servicing equipment.</li> <li>Tighten all fluid connections before operating the equipment.</li> <li>Check hoses and couplings daily. Replace worn or damaged parts immediately.</li> </ul>
	<p><b>BURN HAZARD</b></p> <p>Equipment surfaces and fluid that is heated can become very hot during operation. To avoid severe burns:</p> <ul style="list-style-type: none"> <li>Do not touch hot fluid or equipment.</li> </ul>
	<p><b>FIRE AND EXPLOSION HAZARD</b></p> <p>Flammable fumes, such as solvent and paint fumes, in <b>work area</b> can ignite or explode. Paint or solvent flowing through the equipment can cause static sparking. To help prevent fire and explosion:</p> <ul style="list-style-type: none"> <li>Use equipment only in well-ventilated area.</li> <li>Eliminate all ignition sources; such as pilot lights, cigarettes, portable electric lamps, and plastic drop cloths (potential static sparking).</li> <li>Ground all equipment in the work area. See <b>Grounding</b> instructions.</li> <li>Never spray or flush solvent at high pressure.</li> <li>Keep work area free of debris, including solvent, rags and gasoline.</li> <li>Do not plug or unplug power cords, or turn power or light switches on or off when flammable fumes are present.</li> <li>Use only grounded hoses.</li> <li>Hold gun firmly to side of grounded pail when triggering into pail. Do not use pail liners unless they are anti-static or conductive.</li> <li><b>Stop operation immediately</b> if static sparking occurs or you feel a shock. Do not use equipment until you identify and correct the problem.</li> <li>Keep a working fire extinguisher in the work area.</li> </ul>

# **WARNING**



## **EQUIPMENT MISUSE HAZARD**

Misuse can cause death or serious injury.



- Do not operate the unit when fatigued or under the influence of drugs or alcohol.
- Do not exceed the maximum working pressure or temperature rating of the lowest rated system component. See **Technical Specifications** in all equipment manuals.
- Use fluids and solvents that are compatible with equipment wetted parts. See **Technical Specifications** in all equipment manuals. Read fluid and solvent manufacturer's warnings. For complete information about your material, request Safety Data Sheets (SDSs) from distributor or retailer.
- Turn off all equipment and follow the **Pressure Relief Procedure** when equipment is not in use.
- Check equipment daily. Repair or replace worn or damaged parts immediately with genuine manufacturer's replacement parts only.
- Do not alter or modify equipment. Alterations or modifications may void agency approvals and create safety hazards.
- Make sure all equipment is rated and approved for the environment in which you are using it.
- Use equipment only for its intended purpose. Call your distributor for information.
- Route hoses and cables away from traffic areas, sharp edges, moving parts, and hot surfaces.
- Do not kink or over bend hoses or use hoses to pull equipment.
- Keep children and animals away from work area.
- Comply with all applicable safety regulations.



## **PERSONAL PROTECTIVE EQUIPMENT**

Wear appropriate protective equipment when in the work area to help prevent serious injury, including eye injury, hearing loss, inhalation of toxic fumes, and burns. Protective equipment includes but is not limited to:

- Protective eyewear, and hearing protection.
- Respirators, protective clothing, and gloves as recommended by the fluid and solvent manufacturer.

# Component Identification

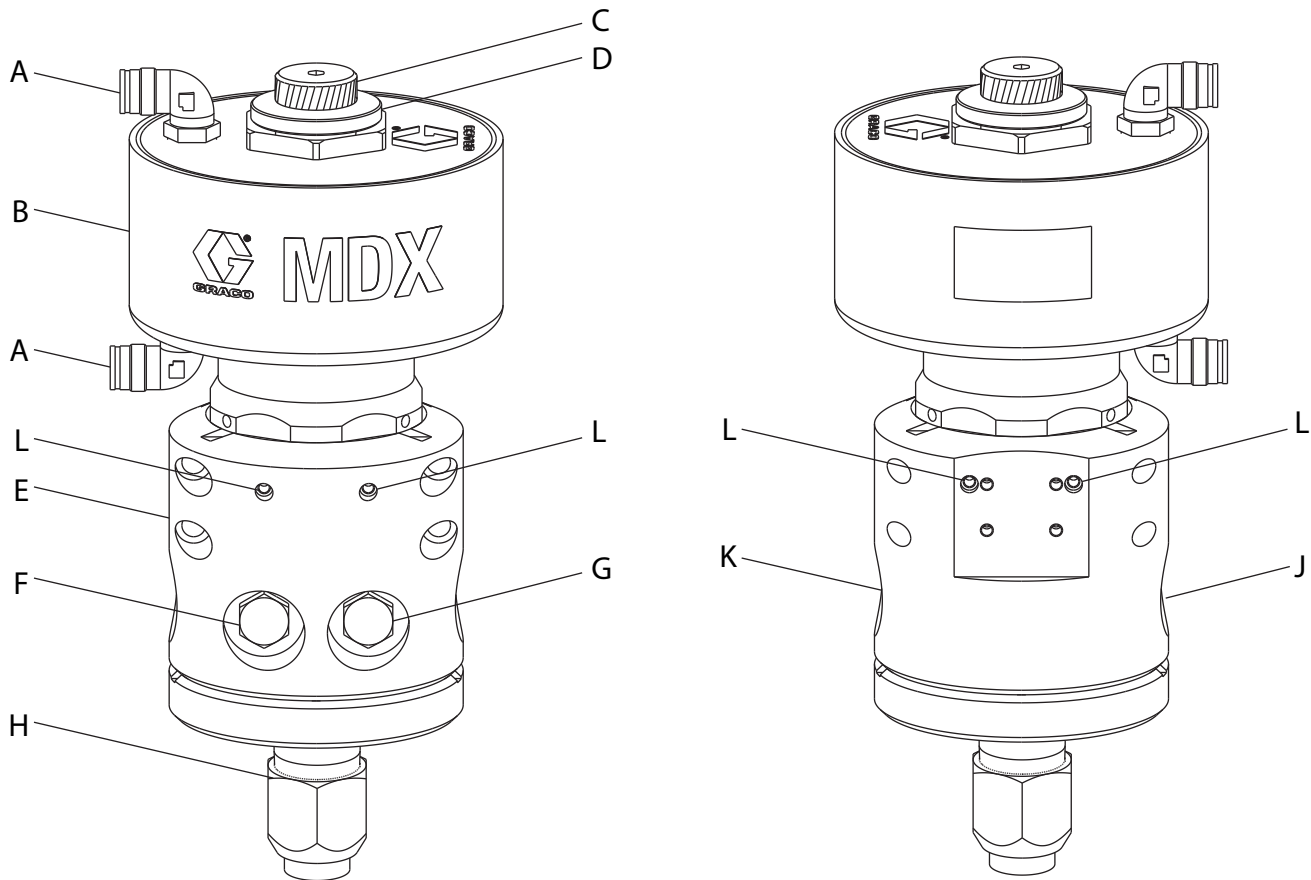

**Fig. 1: 3/4 in. npt Dispense Valve - Typical Components**

**Key:**

- A Air Connections
- B Air Section
- C Travel Adjuster
- D Lock Nut
- E Fluid Section
- F Recirculation Port Plug A
- G Recirculation Port Plug B
- H Fluid Outlet
- J Fluid Inlet A
- K Fluid Inlet B
- L Grease Zerk Fittings

## Theory of Operation

The valve uses the air-opened and air-closed mode of operation, therefore, it uses a four-way exhausting solenoid to control the piston inside the valve.

The valve has four npt fluid inlet ports. Two fluid inlet ports are supply ports, feeding material into the dispense valve. Use other two fluid inlet ports to recirculate material through the valve, or leave them plugged with supplied npt plugs. The fluid outlet port dispenses material through the outlet housing in regulated amounts.

The air-operated piston, rod, and ball move at the same time. When air moves the piston, rod, and ball from their seat, it opens the fluid outlet port. When air pushes the piston, rod, and ball into their seat, it closes the fluid port.

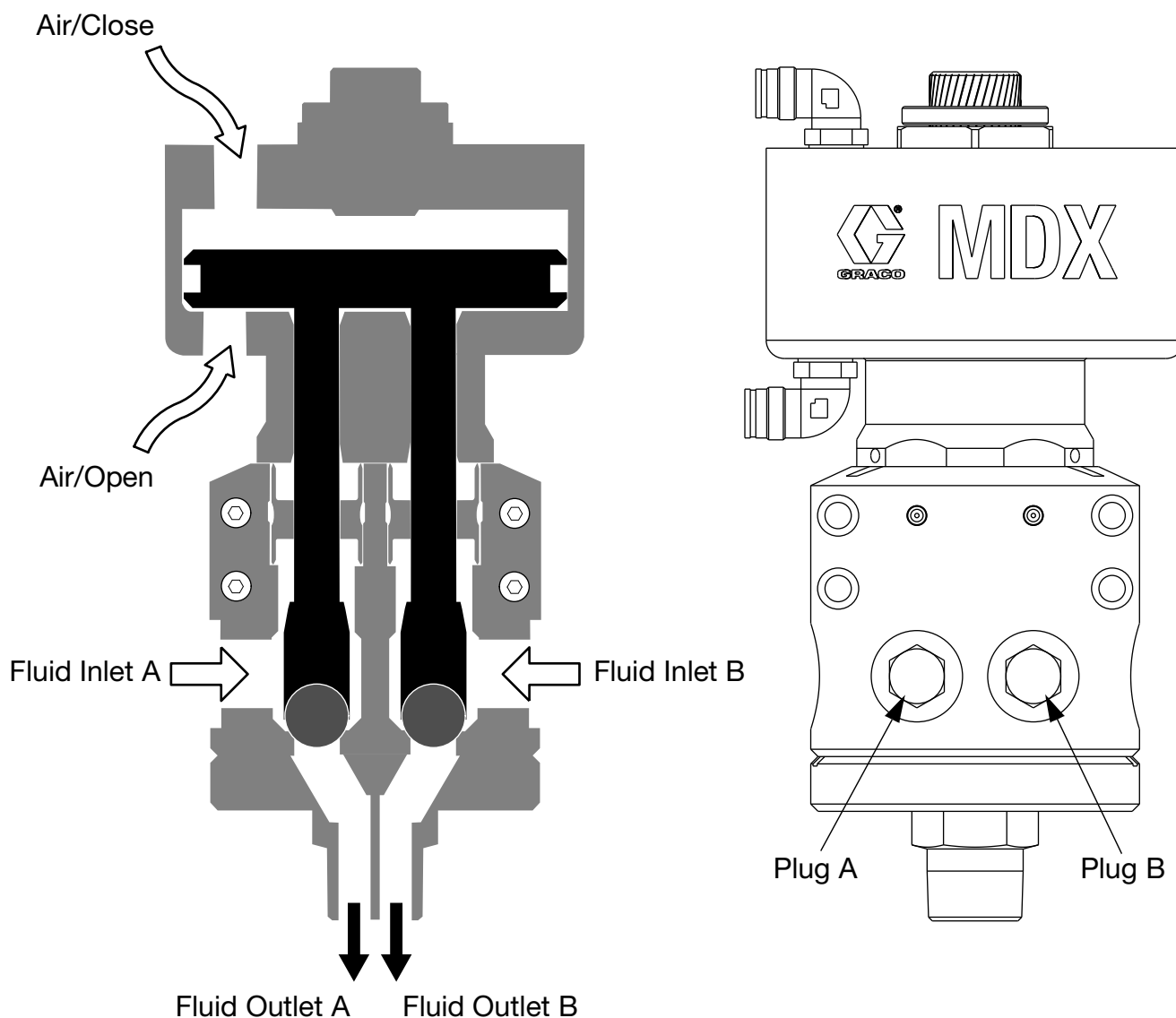

The system provides pressurized fluid to the valve and the system air controls open and close the valve controlling the fluid flow.



**FIG. 2: Theory of Operation**

# Installation

## Grounding

				
<p>The equipment must be grounded to reduce the risk of static sparking. Static sparking can cause fumes to ignite or explode. Grounding provides an escape wire for the electric current.</p>				

**Pump:** use ground wire and clamp. Connect ground clamp to a true earth ground as shown in separate pump manual.

**Air and fluid hoses:** use only electrically conductive hoses with a maximum of 100 ft. (30.5 m) combined hose length to ensure grounding continuity. Check electrical resistance of hoses. If total resistance to ground exceeds 25 megohms, replace hose immediately.

**NOTE:** Use a meter that is capable of measuring resistance at this level.

**Air compressor:** follow manufacturer's recommendations.

**Dispense valve:** ground through connection to a properly grounded fluid hose and pump.

**Fluid supply container:** follow local code.

**Solvent pails used when flushing:** follow local code. Use only conductive metal pails placed on a grounded surface. Do not place the pail on a nonconductive surface, such as paper or cardboard, which interrupts grounding continuity.

**To maintain grounding continuity when flushing or relieving pressure:** ensure metal part of dispense valve is in contact with a grounded metal waste container before actuating the valve.

## Flush Before Using Equipment

The equipment was tested with lightweight oil, which is left in the fluid passages to protect parts. To avoid contaminating your fluid with oil, flush the equipment with a compatible solvent before using the equipment.



## Mounting

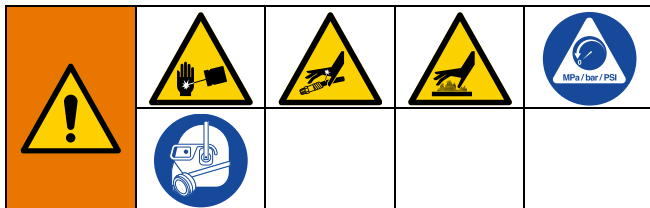

The dispense valves have multiple mounting hole configurations (see **Dimensions**, page 21), which make them ideal for use with robotic equipment or multiple manifold high production operations.

1. Inspect dispense valve for shipping damage. If there is damage, notify shipping carrier immediately.
2. Install compatible accessories. For a list of accessories and installation instructions, see **Kits and Accessories**, page 20.

**NOTE:** Follow **Pressure Relief Procedure**, page 10, before changing outlet housing.

3. Securely attach the dispense valve to its mounting fixture using socket head cap screws; see **Dimensions**, page 21.
4. Connect air lines to the dispense valve:

### NOTICE

Only use air fittings that are rated at a temperature equal to or higher than the operating temperature of the fluid dispensing system. Lower rated air fittings could melt and cause damage to the dispense valve.

- a. See **Technical Specifications**, page 22, for maximum operating air pressure.
  - b. Connect air line to air/open air inlet in air section (B). See FIG. 2, page 7.
  - c. Connect air line to air/close air inlet in air section (B). See FIG. 2, page 7.
5. Connect fluid line to npt fluid inlet (J and K) in valve body. For circulation systems, remove plug from other inlet (F and G) and connect fluid return line. See **Technical Specifications**, page 22, for maximum operating fluid pressure.

6. Check each fitting to avoid pressure leakage from the dispense valve.

# Operation

## Pressure Relief Procedure



Follow the Pressure Relief Procedure whenever you see this symbol.

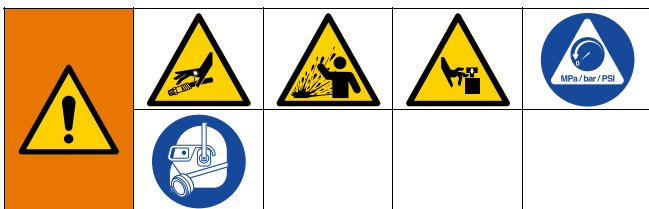

This equipment stays pressurized until pressure is manually relieved. To help prevent serious injury from pressurized fluid, such as skin injection, splashing fluid and moving parts, follow the Pressure Relief Procedure when you stop spraying and before cleaning, checking, or servicing the equipment.

This procedure describes how to relieve pressure from the dispense valve only. See the supply system manual for instructions on relieving pressure from the entire system.

1. Shut off material supply.
2. Actuate the valve and dispense fluid into a grounded metal waste container to relieve the fluid pressure.
3. Shut off air supply to relieve all air pressure in the air lines.
4. If the outlet housing or fluid hose is clogged or if pressure has not been fully relieved after following the steps above, **VERY SLOWLY** loosen the npt inlet fitting from the dispense valve or hose end coupling to relieve pressure gradually, then loosen completely. Clear outlet housing or hose obstruction.

## Adjust Stroke

Adjust the distance that the dispense valve opens to restrict the flow of material through the ball and seat. See Fig. 4.

1. Loosen the lock nut (D).
2. Cycle air pressure to close valve.
3. Turn the travel adjuster (C) clockwise until the valve is held closed.
4. Cycle air pressure to open the valve. Ensure material does not dispense.
5. Slowly open the travel adjuster (C) and then cycle the air pressure until the desired flow is reached.
6. Tighten lock nut (D) to hold the travel adjuster (C) in place.

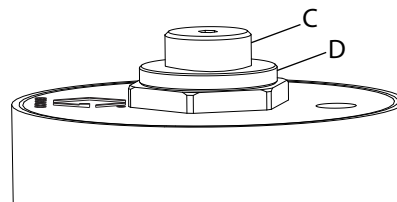

**FIG. 3: 3/4 in. Valve**

## Check Ratio

The output mix ratio of the dispense valve can be checked by dispensing the two fluids separately out of the outlet housing into tared cups. Weigh the cups to get the mix ratio by weight.

Use ratio check nozzles 18F424 with retaining nut 18F425 for 1:1 models to make ratio checks.

Ratio checks provide information on the ratio of an overall sample. Transient problems (soft spots) caused by starting and stopping the flow (lead-lag) may not show up in this kind of ratio check. Physical tests of the mixed fluid are the best check of correct ratio and mix quality.

# Maintenance

Inspect the dispense valve, material, and air hoses at least once every two weeks. Inspect for leakage and other visible damage daily. If there is any leakage or damage, change the part immediately. Follow the **Repair**, on page 15.

The following table lists recommended maintenance procedures and frequencies. A typical application is a valve mounted on a robot dispensing a moderately abrasive sealant.

Task	Weekly	Monthly or 30,000 cycles
Check hoses for wear*	4	
Check/tighten fluid connections*	4	
Check/tighten air connections*	4	
Check stroke adjustment	4	
Lubricate packings		4

\* Assumes movement from automation.

## Packing Lubrication



This valve has a primary seal, a pressurized grease area, and a secondary seal. The key to long seal life is ensuring that the secondary seal only has to seal grease and is not exposed to other material.

When dispensing filled materials this grease should be refilled once a month. Complete the following procedure to avoid pushing grease into the fluid stream

1. Perform the **Pressure Relief Procedure**, on page 10.
2. Remove two grease zerk fittings (111).

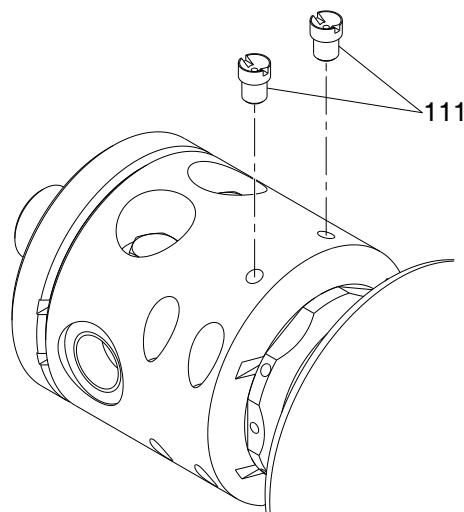

**FIG. 4**

3. Use a grease gun (part no. 551189) and nozzle (part no. 2002051) to pump a high quality grease (part no. 115982, high temperature moisture free) into the grease zerk fitting (111) until fresh grease comes out the other side.
4. Reinstall the grease zerk fitting (111) and give the valve one more shot of grease through the grease zerk fitting (111) to pressurize the cavity.

**NOTE:** Grease can enter the fluid section if more than one shot is triggered after the grease zerk fitting or plug has been replaced.

## Factors Affecting Valve Life

The maintenance tables should be used as a guideline for maintenance frequency. Additional factors that could affect valve life include the following:

- Process Fluid - Abrasive or fiber filled fluids are much harder on seals, shafts, and seats than non-abrasive fluids, such as oil.
- Pressure drop across the valve seat - As the valve opens or closes, the fluid is accelerated to a high velocity at the needle/seat contact area. The rate of wear at the valve will be much greater at 3000 psi than at 1000 psi. Changing ball size can have a substantial effect on wear.
- Number of cycles - The number of cycles has a much greater effect on valve wear than number of gallons. If you can do the same job with fewer on/off cycles, the valve will last longer.
- Speed of actuation - Opening and closing the valve quickly will decrease needle and seat life. Use short air lines after the solenoid to improve open and close speed. Avoid long air tube runs after the solenoid.
- Air pressure - Air pressure provides the force to hold the carbide ball against the carbide seat, sealing against fluid pressure. Any leakage through these parts at high pressure will quickly "worm-hole" them and cause the valve to wear out sooner.

# Recycling and Disposal

## End of Product Life

At the end of the product's useful life, dismantle and recycle it in a responsible manner.

- Perform the **Pressure Relief Procedure**, page 10.
- Drain and dispose of fluids according to applicable regulations. Refer to the material manufacturer's Safety Data Sheet.
- Deliver remaining product to a recycling facility.

# Troubleshooting

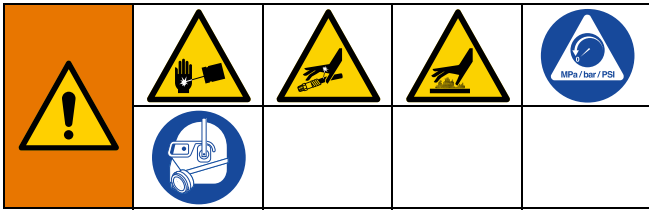

1. Follow **Pressure Relief Procedure**, page 10, before checking or repairing the valve.
2. Check all possible problems and causes before disassembling valve.

Problem	Cause	Solution
Air leaks from dispense valve.	Loose air connections.	Check air connections.
	Worn o-rings.	Replace o-rings in air housing.
	Loose end cap.	Tighten end cap.
Material leaks from front of dispense valve.	Worn o-rings.	Replace o-rings.
	Obstruction inside dispense valve.	Remove outlet housing. Check and replace ball and seat, if damage has occurred.
	Worn ball.	Check and replace ball. It is recommended that you also replace the seat.
	Worn seat.	Check and replace or reverse seat. If replacing the seat, also replace the ball.
Material leaks from dispense valve body.	Seals (u-cup and o-rings) not installed correctly.	Check cartridge seals (u-cup and o-rings) and replace cartridge (u-cup) and rod.
	Worn seals.	
Dispense valve does not shut off.	Loose air connections.	Check air connections.
	Worn seat interface.	Replace ball and seat.
	Broken piston or debris in air cylinder.	Disassemble dispense valve. Check and replace, if necessary, piston, piston rod, and o-rings.
Dispense valve does not open or dispense material.	Loose air connections.	Check air connections.
	Broken rod, piston, or ball.	Disassemble dispense valve. Check piston, piston rod, ball, and o-rings. Replace damaged part.

# Repair

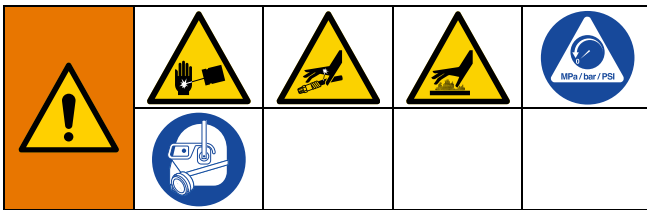

If the valve is hot, wait for it to cool completely before determining whether or not you can repair it. Some materials, like polyurethanes, may cure permanently when cooled and exposed to air, preventing you from disassembling the dispense valve. If you are working with such a material, instead of waiting for the valve to cool completely, repair the valve while the material is at a temperature where the material is soft enough to work with. Alternatively, if the material can be reheated later, you can repair the valve after it has cooled, reheating the material as necessary.

Perform this procedure before servicing the dispense valve.

1. Make sure material supply has been shut off.
2. Perform the **Pressure Relief Procedure**, on page 10.
3. Make sure air supply has been shut off.
4. If the material in the dispense valve can be reheated, wait for the dispense valve to cool thoroughly before repairing it.

If the material in the dispense valve cures permanently when cooled and/or exposed to air, repair the valve while the material is at a temperature where the material is soft enough to work with.

5. Disconnect the air section to repair the valve. See **Disconnect**, on page 15.

## Disconnect

**NOTE:** Always replace o-rings after the valve has been disassembled.

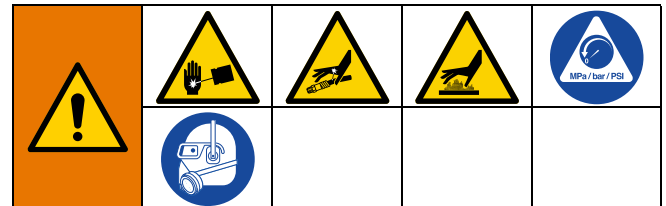

1. Perform steps 1 through 4 from **Repair** procedure, page 15.
2. Loosen four screws (135) and remove outlet housing (105), then loosen two screws (110). Place the fluid section in a vise, pull out the air section and disconnect the fluid and air section.
3. If necessary, replace the old air section with a new air section to reduce downtime. Bring the old air section to a work bench for repair.

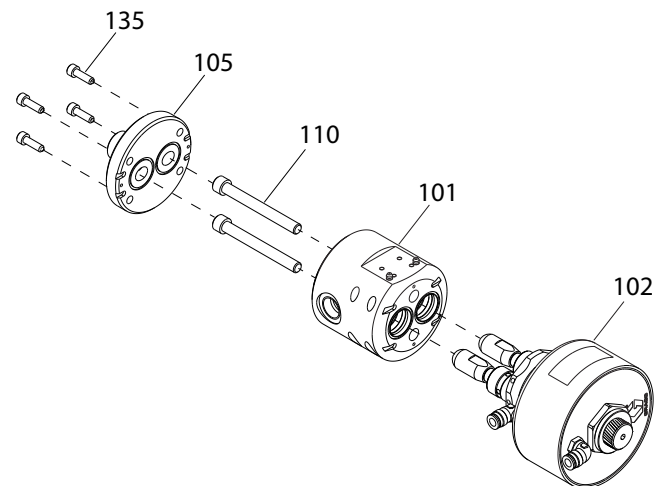

**FIG. 5**

## Disassembly

1. Perform the **Disconnect** procedure, on page 15.
2. Remove four o-rings (114a and 134), two seats (133) and two gaskets (132).

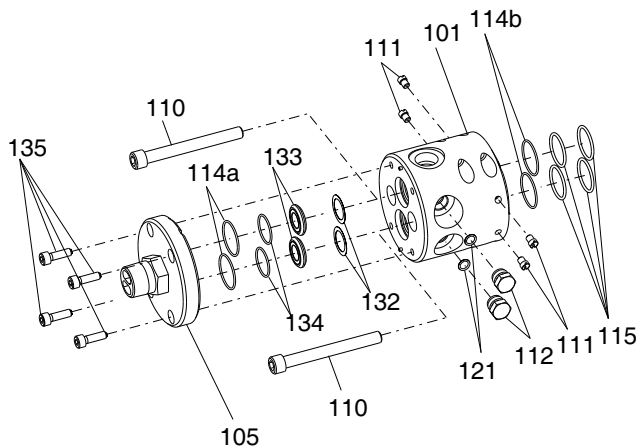

**FIG. 6**

3. Remove two plugs (112) and two o-rings (121).
4. Use an o-ring pick to remove the four o-rings (115) from the fluid housing (101), and then remove two o-rings (114b).
5. Use a wrench on the air cap (104) flats to remove it from the air housing (102).

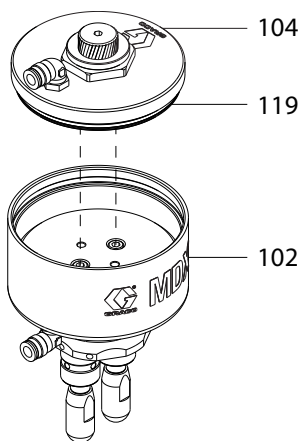

**FIG. 7**

6. Place a wrench on the ball (106) flats. Remove two balls from the piston rod.

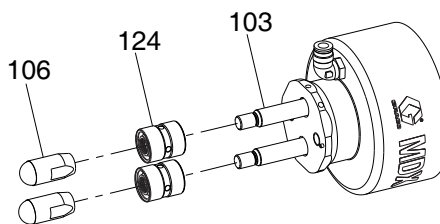

**FIG. 8**

7. Use a rubber mallet to drive the piston rod assembly (103) through the u-cup cartridge (124).
8. Remove the piston rod assembly from the air housing (102). Inspect the piston, piston rod, and air housing for damage. Replace if necessary.
9. Remove retaining ring (113). Loosen the lock nut (109) and unthread the travel adjuster (108).
10. Remove the o-rings (117, 118, 119, and 120).

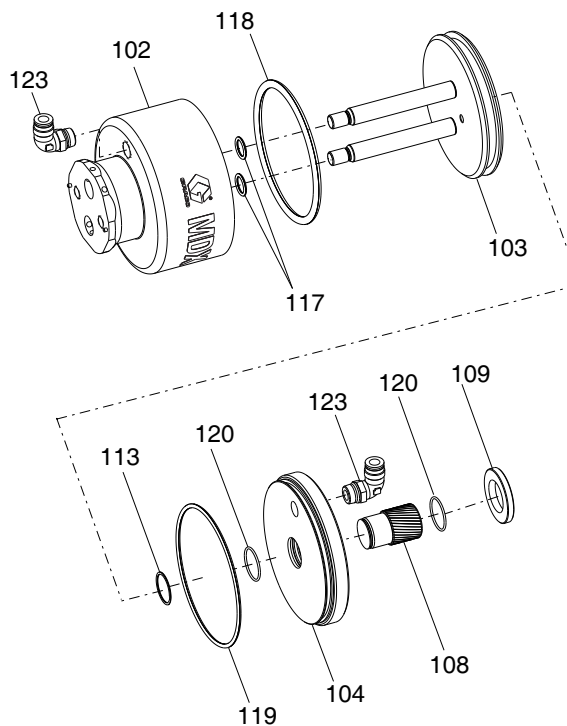
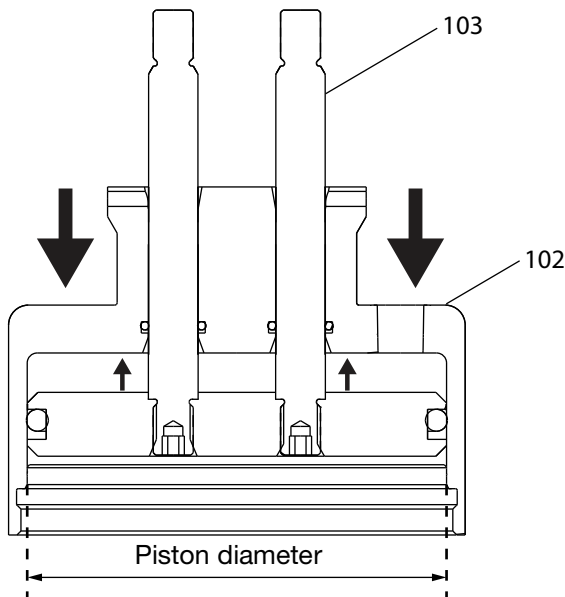

**FIG. 9**



## Assembly

1. Install new o-rings (118, 117) on the piston rod assembly (103) and in the air housing (102). See FIG. 9.
2. Apply a thin coat of grease to the piston o-ring (118) and inside wall of the air housing (102).
3. Place the top of the piston rod assembly (103) on a surface smaller than the piston rod diameter. Press the air housing (102) down over the piston rod.



**FIG. 10**

4. Install new o-ring (120) in the end cap (104). Apply with grease. See FIG. 9.
5. Thread the travel adjuster (108) in the end cap (104). Place second o-ring (120) over travel adjuster threads and tighten with the lock nut (109), retaining ring (113) and o-ring (120). See FIG. 9.
6. Apply grease on the piston rod and install the u-cup cartridge (107) against the air housing (102) with the open end of the u-cups facing away from the air section. See FIG. 8.
7. Wipe grease off the piston rod threads. Apply purple anaerobic adhesive (supplied with repair kit) on the male and female threads, then install the ball (106). Torque to 40 ft-lbs (54 N•m). See FIG. 8.

### NOTICE

To prevent the ball from loosening and causing equipment damage, allow the anaerobic adhesive to set for 24 hours before running the valve.

8. Install o-ring (119) onto air cap (104). Tighten air cap onto air housing (102). Torque to 30 ft-lbs (41 N•m).
9. Install four new o-rings (115) inside the fluid housing (101) and two o-rings (114b) into the groove. Apply with grease. See FIG. 6.
10. Install new o-rings (121) and reinstall plugs (112).
11. Push the air section (102) into the fluid housing (101). Install new gaskets (132), seats (133), and new o-rings (134). Tighten the screw (110) onto the fluid housing (101). Torque to 40-45 ft-lbs (54.2-61.0 N•m)
12. Install new o-ring (114a) and reinstall the outlet housing (105). Tighten four screws (135) onto the outlet housing (105). Torque to 30-35 ft-lbs (40.7-47.5 N•m).

# Parts

## 3/4 in. npt Fluid Section

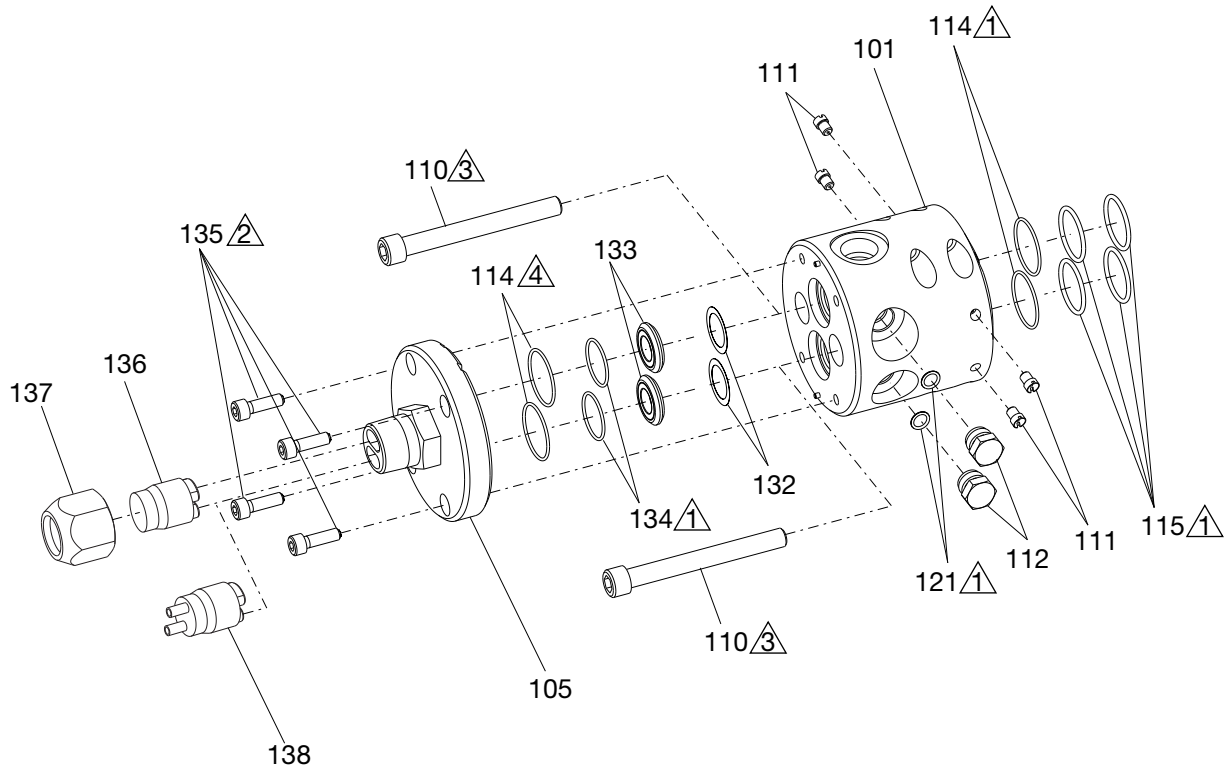

△1 Apply a thin coat of grease to surface.

△3 Torque to 18.4-22.1 lbs-ft (25-30 N•m).

△2 Torque to 11.1-14.8 lbs-ft (15-20 N•m).

△4 Apply a thin coat of lubricant to surface.

Ref.	Part	Description	Qty.
101	18F411	HOUSING, fluid section, MDX	1
105	18F416	HOUSING, outlet, MDX, 1 npt	1
110	18F417	SCREW, shc, M12 x 1.75 x 110, CS, zinc	2
111	18F418	FITTING, lubrication, st	4
112	198241	PLUG, port, pressure	2
114*	102895	O-RING, 028, viton	4
115*	125249	O-RING, 124, FX75	2
121*	121399	PACKING, o-ring, 012, FX75	2
132*	18F421	GASKET, seat, 0.004, PTFE	2
133	196866	SEAT, carbide, 7/8 ball	2
134*	108526	O-RING, 024, PTFE	2
135	16K289	SCREW, shc, M8 x 1.25 x 25, SST	4
136	18F426	CAP, night 1:1	1
137	18F425	NUT, ratio check 1:1	1
138	18F424	ADAPTER, ratio check 1:1	1

\* Parts included in Fluid Section O-Ring Repair Kit 26D439 (purchase separately).

### 3/4 in. npt Air Section

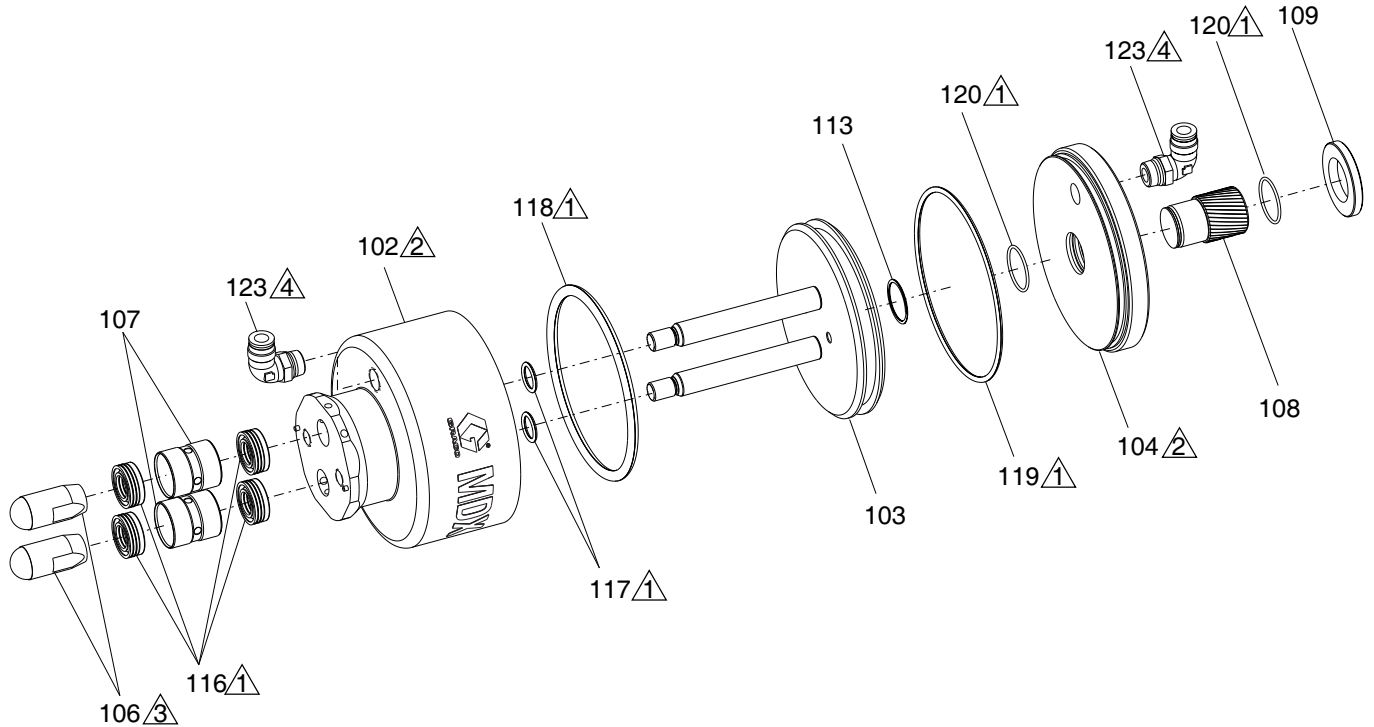

▲ Apply a thin coat of grease to surface.

▲ Torque to 11.1-14.8 lbs-ft (15-20 N•m).

▲ Torque to 18.4-22.1 lbs-ft (25-30 N•m).

▲ Apply thread sealant to threads.

Ref.	Part	Description	Qty.
102	18F412	HOUSING, air section, MDX	1
103	26D312	PISTON ROD, assy, MDX	1
104	18F420	CAP, air, adjustable, 3/4 in.	1
106	16G263	BALL, housing, assy, 3/4 in.	2
107*	16D230	CARTRIDGE, seal, 3/4 in.	2
108†	16F748	ADJUSTER, travel, 3/4 in.	1
109†	16F749	NUT, lock, adjustment, 3/4 in.	1
113†	124782	RING, retaining, external, SST	1
116*	18F419	SEAL, U-cap, 1-1/8x5/8	4
117✓	124887	O-RING, 114, viton	2
118✓	124811	O-RING, 427, viton	1
119✓	124810	O-RING, 250, viton	1
120†✓	177156	PACKING, O-ring	2
123	18F413	FITTING, elbow, male, swivel	2

\* One Cartridge and two seals included in U-Cap Cartridge Repair Kit 26D440 (purchase separately).

✓ Parts included in Air Section O-Ring Repair Kit 26D438 (purchase separately).

† Parts included in Adjuster Repair Kit 26D442 (purchase separately).

# Kits and Accessories

Before installing any accessories, perform the **Pressure Relief Procedure**, on page 10.

## Grease Gun, 551189 and 2002051

Use to pump grease into the zerk fitting.

## Mixer

### Mixer, 513375

Mixer thread: 3/4 in. npt (m), with factor, metal shroud.

### Mixer 1", 2003977

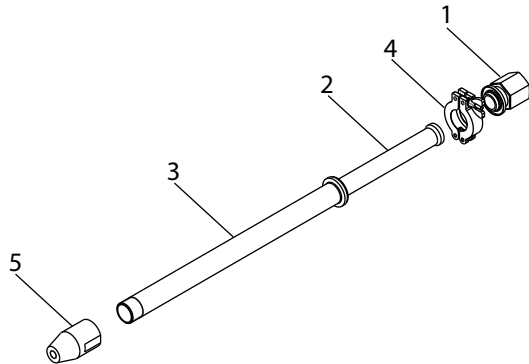

FIG. 11

Ref.	Part	Description	Qty.
1	---	CONNECTOR, outlet	1
2	2003979	MIXER, 1"	1
3	2003980	SHROUD, mixer, 1"	1
4	---	CLAMP, 25, MDX	1
5	---	ADAPTER, mixer outlet, MDX	1

## Fitting, 122639

Swivel, 1 npt x 3/4 npt, ff, ms, 3k, stainless steel

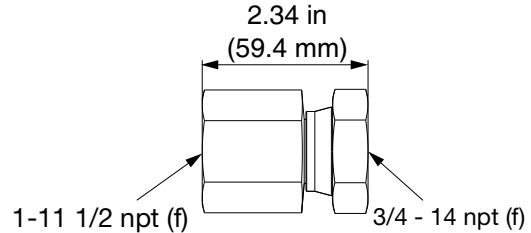
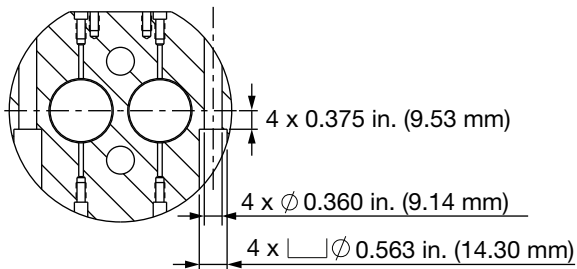
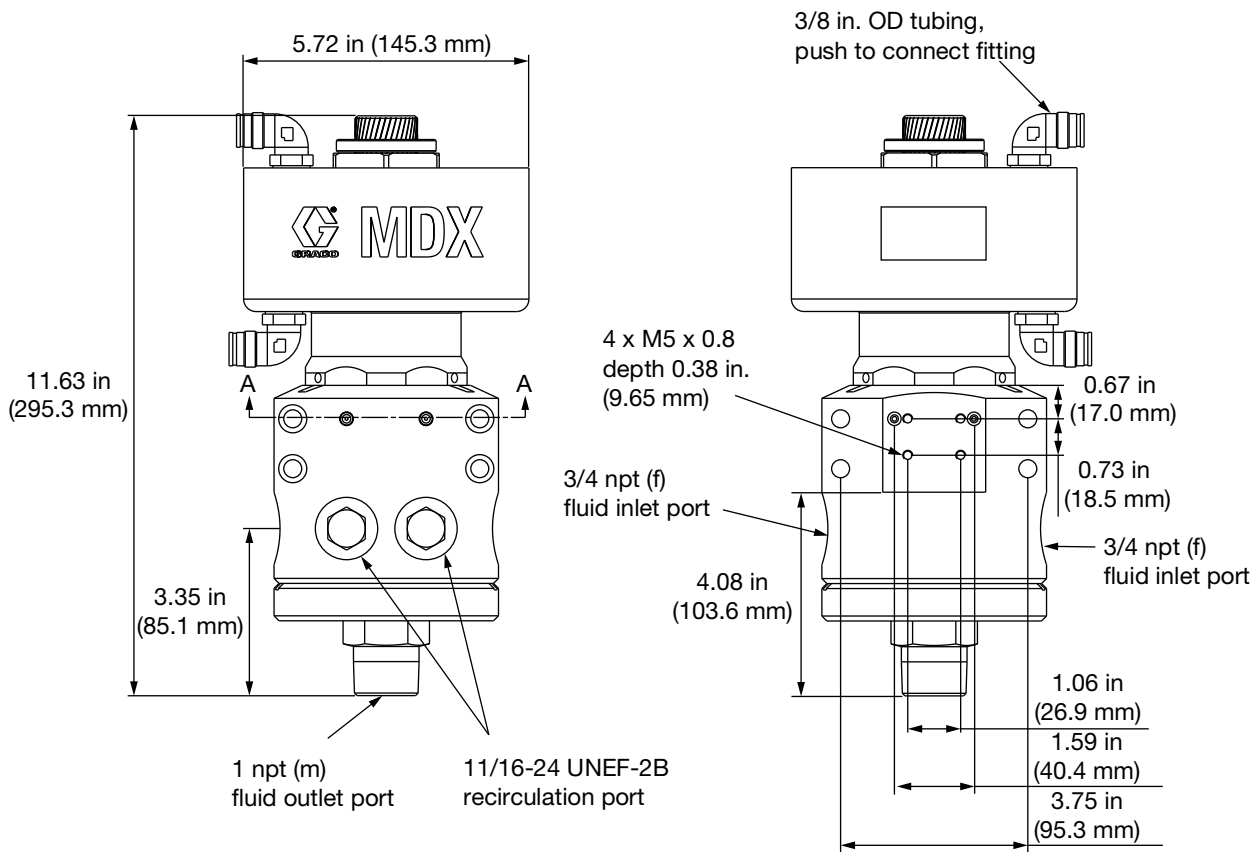

FIG. 12

## Ratio Check, 2003978

Fig.	Part	Description	Qty.
	2003983	NOZZLE, ratio check	1
	2003984	TUBE, ratio check, A=2 mm	2
	2003985	TUBE, ratio check, A=2.5 mm	2
	2003986	TUBE, ratio check, A=3 mm	2
	2003987	TUBE, ratio check, A=3.5 mm	2
	2003988	TUBE, ratio check, A=4 mm	2

# Dimensions



Section A

# Technical Specifications

<b>MDX Dispense Valve</b>		
	<b>US</b>	<b>Metric</b>
Maximum air working pressure	100 psi	0.7 MPa, 7 bar
Maximum fluid working pressure	3000 psi	20.68 MPa, 206.8 bar
Maximum fluid operating temperature	158 °F	70 °C
Weight	26.79 lb	12.15 kg
Wetted materials on all models	Stainless steel, tungsten carbide, chemical resistant fluoroelastomer rubber, UHMWPE, ceramic	
<b>Notes</b>		
All trademarks or registered trademarks are the property of their respective owners.		

# California Proposition 65

## CALIFORNIA RESIDENTS

 **WARNING:** Cancer and reproductive harm – [www.P65warnings.ca.gov](http://www.P65warnings.ca.gov).

# Graco Standard Warranty

Graco warrants all equipment referenced in this document which is manufactured by Graco and bearing its name to be free from defects in material and workmanship on the date of sale to the original purchaser for use. With the exception of any special, extended, or limited warranty published by Graco, Graco will, for a period of twelve months from the date of sale, repair or replace any part of the equipment determined by Graco to be defective. This warranty applies only when the equipment is installed, operated and maintained in accordance with Graco's written recommendations.

This warranty does not cover, and Graco shall not be liable for general wear and tear, or any malfunction, damage or wear caused by faulty installation, misapplication, abrasion, corrosion, inadequate or improper maintenance, negligence, accident, tampering, or substitution of non-Graco component parts. Nor shall Graco be liable for malfunction, damage or wear caused by the incompatibility of Graco equipment with structures, accessories, equipment or materials not supplied by Graco, or the improper design, manufacture, installation, operation or maintenance of structures, accessories, equipment or materials not supplied by Graco.

This warranty is conditioned upon the prepaid return of the equipment claimed to be defective to an authorized Graco distributor for verification of the claimed defect. If the claimed defect is verified, Graco will repair or replace free of charge any defective parts. The equipment will be returned to the original purchaser transportation prepaid. If inspection of the equipment does not disclose any defect in material or workmanship, repairs will be made at a reasonable charge, which charges may include the costs of parts, labor, and transportation.

**THIS WARRANTY IS EXCLUSIVE, AND IS IN LIEU OF ANY OTHER WARRANTIES, EXPRESS OR IMPLIED, INCLUDING BUT NOT LIMITED TO WARRANTY OF MERCHANTABILITY OR WARRANTY OF FITNESS FOR A PARTICULAR PURPOSE.**

Graco's sole obligation and buyer's sole remedy for any breach of warranty shall be as set forth above. The buyer agrees that no other remedy (including, but not limited to, incidental or consequential damages for lost profits, lost sales, injury to person or property, or any other incidental or consequential loss) shall be available. Any action for breach of warranty must be brought within two (2) years of the date of sale.

**GRACO MAKES NO WARRANTY, AND DISCLAIMS ALL IMPLIED WARRANTIES OF MERCHANTABILITY AND FITNESS FOR A PARTICULAR PURPOSE, IN CONNECTION WITH ACCESSORIES, EQUIPMENT, MATERIALS OR COMPONENTS SOLD BUT NOT MANUFACTURED BY GRACO.** These items sold, but not manufactured by Graco (such as electric motors, switches, hose, etc.), are subject to the warranty, if any, of their manufacturer. Graco will provide purchaser with reasonable assistance in making any claim for breach of these warranties.

In no event will Graco be liable for indirect, incidental, special or consequential damages resulting from Graco supplying equipment hereunder, or the furnishing, performance, or use of any products or other goods sold hereto, whether due to a breach of contract, breach of warranty, the negligence of Graco, or otherwise.

## **FOR GRACO CANADA CUSTOMERS**

The Parties acknowledge that they have required that the present document, as well as all documents, notices and legal proceedings entered into, given or instituted pursuant hereto or relating directly or indirectly hereto, be drawn up in English. Les parties reconnaissent avoir convenu que la rédaction du présente document sera en Anglais, ainsi que tous documents, avis et procédures judiciaires exécutés, donnés ou intentés, à la suite de ou en rapport, directement ou indirectement, avec les procédures concernées.

# Graco Information

## Sealant and Adhesive Dispensing Equipment

For the latest information about Graco products, visit [www.graco.com](http://www.graco.com).

For patent information, see [www.graco.com/patents](http://www.graco.com/patents).

**TO PLACE AN ORDER**, contact your Graco distributor, go to [www.graco.com](http://www.graco.com), or call to identify the nearest distributor.

**If calling from the USA:** 1-800-746-1334

**If calling from Asia Pacific:** 00-86-512-6260-5711 or 00-86-21-2310-6198

**If calling from Europe:** 00-32-89-770-862

*All written and visual data contained in this document reflects the latest product information available at the time of publication. Graco reserves the right to make changes at any time without notice.*

Original instructions. This manual contains English. MM 3A8814F

**Graco Headquarters:** Minneapolis

**International Offices:** Belgium, China, Japan, Korea

**GRACO INC. AND SUBSIDIARIES • P.O. BOX 1441 • MINNEAPOLIS MN 55440-1441 • USA**  
**Copyright 2021, Graco Inc. All Graco manufacturing locations are registered to ISO 9001.**

[www.graco.com](http://www.graco.com)  
Revision F, September 2024