

# Hose Reel Swivel Kit

3A8689A

EN

---

*For swivel replacement on SD and XD 10/20 Series Hose Reels only. For professional use only.*



### Important Safety Instructions

Read all warnings and instructions in this manual and in SD and XD 10/20 Series Hose Reels Instruction manual before using the equipment. Save all instructions.

### Kit Selection:

See **Kits** table on page 2 to determine the correct replacement kit(s) for your specific hose reel.

### Related Manuals





Manual in English	Description
3A8626	SD and XD 10/20 Series Hose Reels

# Kits

Reel P/N	Frame Size	Fluid	Maximum Working Pressure	Hose Size (in./mm)	Hose Length (ft./mm)	Swivel Kit
SDL2D#	SD10	Air/Water	300 psi (2.07 MPa, 20.7 bar)	3/8	50	133502
SDL6D#	SD20	Air/Water		1/2	50	133503
SDL23#	SD10	Air/Water		3/8	35	133502
SDL25#	SD10	Air/Water		3/8	50	133502
SDL56#	SD20	Air/Water		3/8	65	133502
SDL5J#	SD Truck 20	Air/Water		3/8	65	133502
SDL33#	SD10	Air/Water		1/2	35	133503
SDL65#	SD20	Air/Water		1/2	50	133503
SDL6H#	SD Truck 20	Air/Water		1/2	50	133503
SDM3B#	SD10	Oil		2000 psi (13.8 MPa, 137.9 bar)	1/2	35
SDM6D#	SD20	Oil	1/2		50	133504
SDM33#	SD10	Oil	1/2		35	133504
SDM65#	SD20	Oil	1/2		50	133504
SDM6H#	SD Truck 20	Oil	1/2		50	133504
SDH1D#	SD10	Grease	8000 psi (55.2 MPa, 551.6 bar)	1/4	50	133505
SDH5D#	SD20	Grease		3/8	50	133505
SDH15#	SD10	Grease		1/4	50	133505
SDH23#	SD10	Grease		3/8	35	133505
SDH55#	SD20	Grease		3/8	50	133505
SDH5H#	SD Truck 20	Grease		3/8	50	133505
XDL2D#	XD10	Air/Water	300 psi (2.07 MPa, 20.7 bar)	3/8	50	133509
XDL6D#	XD20	Air/Water		1/2	50	133508
XDL25#	XD10	Air/Water		3/8	50	133509
XDL33#	XD10	Air/Water		1/2	35	133508
XDL56#	X20	Air/Water		3/8	65	133509
XDL65#	XD20	Air/Water		1/2	50	133508
XDM3B#	XD10	Oil	2000 psi (13.8 MPa, 137.9 bar)	1/2	35	133507
XDM6D#	XD20	Oil		1/2	50	133507
XDM33#	XD10	Oil		1/2	35	133507
XDM65#	XD20	Oil		1/2	50	133507
XDH15#	SD10	Grease	8000 psi (55.2 MPa, 551.6 bar)	1/4	50	133506
XDH1D#	SD10	Grease		1/4	50	133506
XDH5D#	SD20	Grease		3/8	50	133506
XDH55#	SD20	Grease		3/8	50	133506
XNL56D	XD no arm 20	Air/Water	300 psi (2.07 MPa, 20.7 bar)	3/8	65	133509
XNL65D	XD no arm 20	Air/Water		1/2	50	133508
XNM65D	XD no arm 20	Oil	2000 psi (13.8 MPa, 137.9 bar)	1/2	50	133507
XNH55D	XD no arm 20	Grease	8000 psi (55.2 MPa, 551.6 bar)	3/8	50	133506

# Warnings

The following warnings are for the setup, use, grounding, maintenance, and repair of this equipment. The exclamation point symbol alerts you to a general warning and the hazard symbols refer to procedure-specific risks. When these symbols appear in the body of this manual or on warning labels, refer back to these Warnings. Product-specific hazard symbols and warnings not covered in this section may appear throughout the body of this manual where applicable.

 <h1 style="margin: 0;">WARNING</h1>	
    	<p><b>SKIN INJECTION HAZARD</b></p> <p>High-pressure fluid from dispensing device, hose leaks, or ruptured components will pierce skin. This may look like just a cut, but it is a serious injury that can result in amputation. <b>Get immediate surgical treatment.</b></p> <ul style="list-style-type: none"> <li>• Do not point dispensing device at anyone or at any part of the body.</li> <li>• Do not put your hand over the fluid outlet.</li> <li>• Do not stop or deflect leaks with your hand, body, glove, or rag.</li> <li>• Follow the <b>Pressure Relief Procedure</b> when you stop dispensing and before cleaning, checking, or servicing equipment.</li> <li>• Tighten all fluid connections before operating the equipment.</li> <li>• Check hoses and couplings daily. Replace worn or damaged parts immediately.</li> </ul>

# Operation

## Pressure Relief Procedure



Follow the Pressure Relief Procedure whenever you see this symbol.

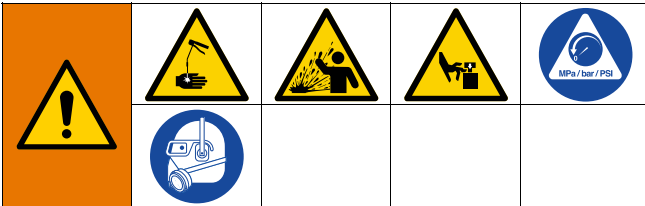

This equipment stays pressurized until pressure is manually relieved. To help prevent serious injury from pressurized fluid, such as skin injection, splashing fluid and moving parts, follow the Pressure Relief Procedure when you stop dispensing and before cleaning, checking, or servicing the equipment.

1. Turn off the power supply to the pump or close the upstream ball valve.
2. Trigger the dispense valve into a waste container to relieve pressure.
3. Open any bleed-type master air valves and fluid drain valves in the system.
4. Leave the drain valve open until ready to pressurize the system.

NOTE: If you suspect that the dispense valve or extension is clogged, or that the pressure has not been fully relieved after following the above steps, very slowly loosen the coupler or hose end coupling to relieve the pressure gradually, then loosen completely. After doing this, the obstruction can be cleared.

## SD Models - Single Pedestal



1. Perform **Pressure Relief Procedure**, page 4.
2. Reduce all spring tension by removing loops of hose from the reel spool. Count the number of loops removed so the same number can be added back after repairing (FIG. 1).

3. Disconnect the hose from the swivel elbow (FIG. 1).
4. Using temporary plugs and caps, plug the swivel assembly being replaced, and cap the hose. This is recommended for liquid applications to minimize spills (FIG. 1).
5. Unscrew the swivel shaft to remove the swivel from the spool shaft (FIG. 1).
6. Lubricate the o-ring on the shaft of the new swivel kit.
7. Attach the new swivel to the spool shaft (FIG. 1).
8. Torque the swivel shaft (30 - 40 ft-lbs, 40.7 - 54.2 N•m).
9. Connect the hose to the swivel elbow (FIG. 1).
10. Reapply the spring tension by adding the same number of hose loops to the reel spool that were removed in Step 2.
11. Test for leaks by slowly applying fluid pressure.



### SPRING TENSION HAZARD

The hose reel spring is always under great tension, which if released in an uncontrolled manner could cause serious injury.

- Never allow the reel to spin freely. Uncontrolled spinning could cause serious injury if hit by the hose.
- Securely fasten the reel in place while making adjustments.
- The hose reel spring is not a serviceable part. Do not attempt to replace or service the hose reel spring.
- Always wear heavy gloves while adjusting the spring tension to protect your hands from being cut on the hose reel.

## XD Models - Dual Pedestal

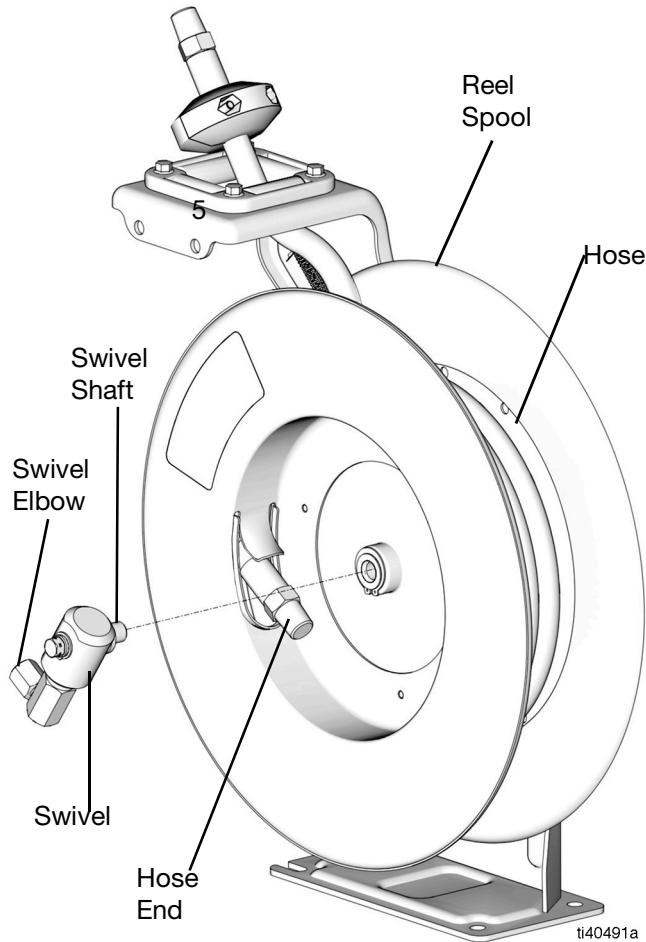

FIG. 1



1. Perform **Pressure Relief Procedure**, page 4.
1. Remove the inlet hose and remove the hose reel from its mounting location.
2. Decrease spring tension:



### SPRING TENSION HAZARD

The hose reel spring is always under great tension, which if released in an uncontrolled manner could cause serious injury.

- Never allow the reel to spin freely. Uncontrolled spinning could cause serious injury if hit by the hose.
- Always grasp the adjusting tool firmly with both hands when adjusting tension. Spring tension can cause the tool to move violently.
- Securely fasten the reel in place while making adjustments.
- The hose reel spring is not a serviceable part. Do not attempt to replace or service the hose reel spring.
- Always wear heavy gloves while adjusting the spring tension to protect your hands from being cut on the hose reel.

- a. Fasten the hose reel securely to a work surface before adjusting spring tension.
- b. Loosen screw (2) 3 to 5 turns. Do not completely remove it (FIG. 2).
- c. Using a hex wrench, loosen the two screws (A). Do not completely remove them (FIG. 2).
- d. Insert a 3/8 in. square drive breaker bar into opening (B) on the spring adjustment plate (C) (FIG. 2).

## Operation

- e. While holding the breaker bar securely, completely remove the two screws (A) (FIG. 2).
- f. While firmly grasping the breaker bar with both hands, turn it counter-clockwise one turn at a time until the spring tension is reduced to zero (FIG. 2).

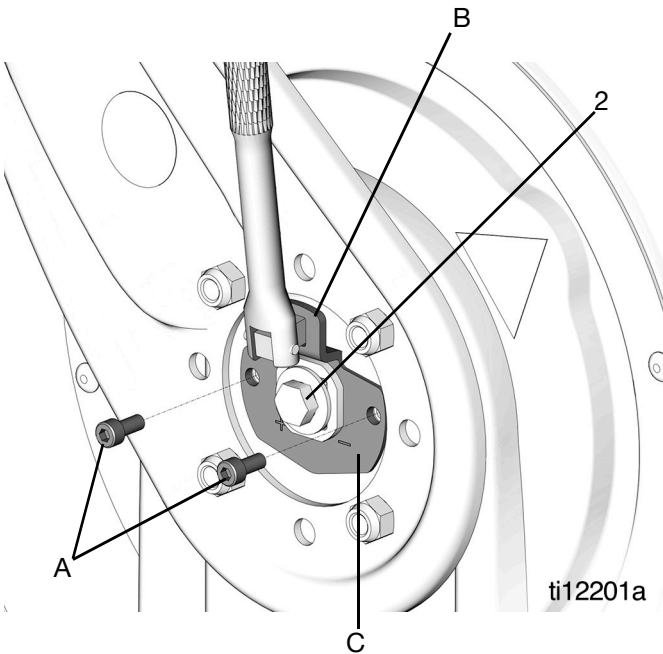

**FIG. 2**

3. Remove the screw (2) and washer (3) (FIG. 3).
4. Remove the screws (1) and nut (10) (FIG. 3).
5. Disconnect the reel hose (not shown) from the swivel elbow (11) (FIG. 3).
6. Lay the reel down on a flat work surface.
7. Remove the swivel-side pedestal (G).
8. Remove the swivel assembly (6) (FIG. 3).

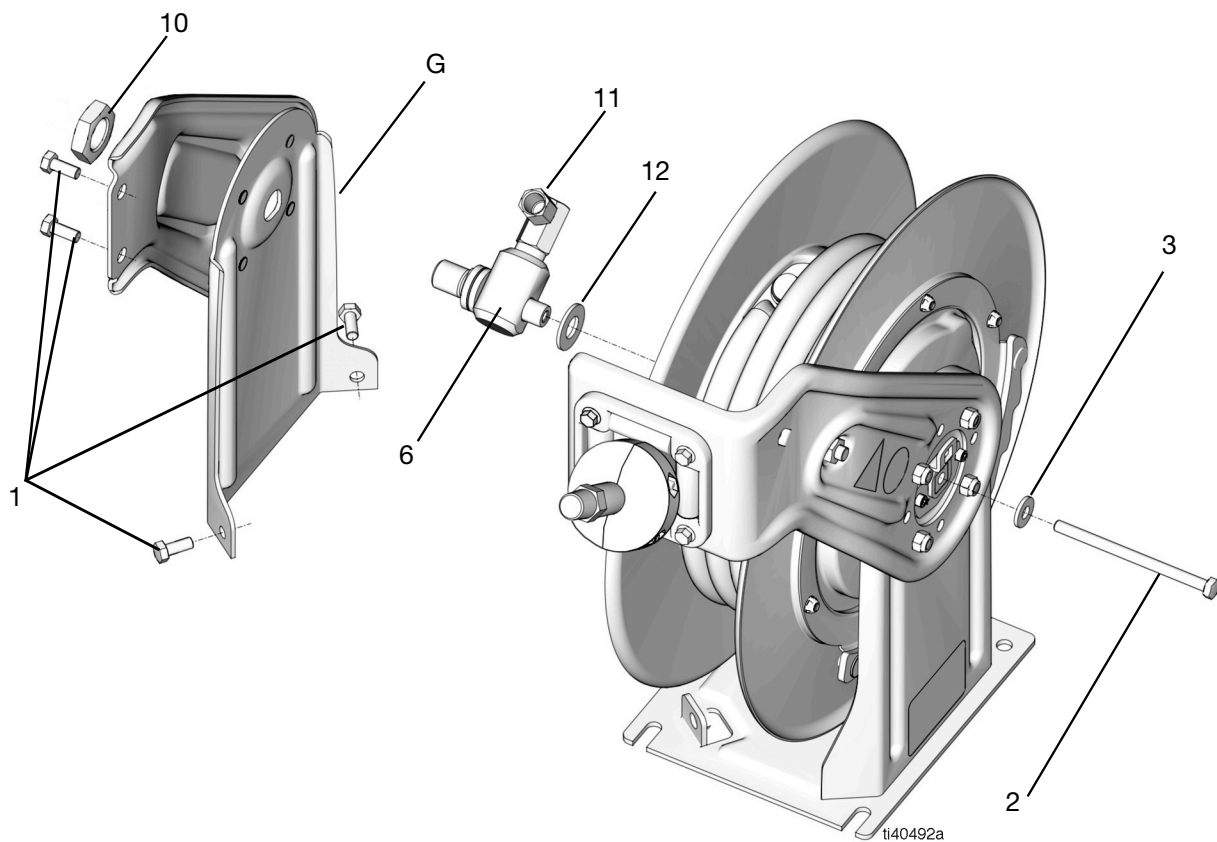

**FIG. 3**

9. Install washer (12) onto the swivel assembly and install the replacement swivel assembly (6) in the hose reel.

NOTE: FIG. 4 shows the correct shape (a) of the swivel assembly end, and the correct alignment of the swivel to the keyhole in the pedestal. For the hose reel to operate correctly, these parts must be aligned correctly.

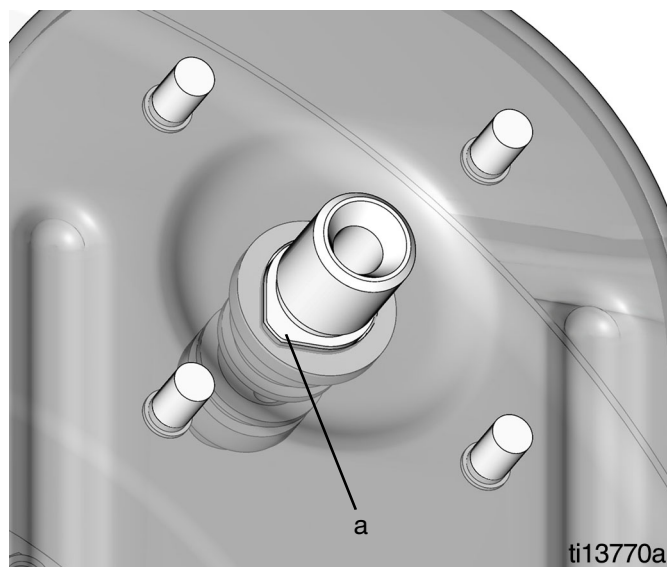

**FIG. 4**

## Operation

10. Install the swivel-side pedestal (G) onto the reel.
11. Replace the nut (10) and screws (1).
12. Reinstall screw (2) and washer (3).
13. Connect the hose (not shown) to the elbow (11).
14. Tighten the spring tension.
  - a. Fasten the hose reel securely to a work surface before adjusting spring tension.
  - b. Insert a 3/8 in. square drive breaker bar into the opening (B) on the spring adjustment plate (C) (see FIG. 2 on page 6).
  - c. Firmly grasp the breaker bar with both hands and turn it clockwise one turn at a time to increase (tighten) the spring tension. This is typically 3 to 5 turns (see FIG. 2 on page 6).
  - d. Replace and partially tighten one screw (A). Remove the breaker bar (see FIG. 2 on page 6).
  - e. Test the tension adjustment by pulling out a section of hose and allowing it to retract.
  - f. If additional tension is required, insert the breaker bar into the bracket again and remove the screw (A). Repeat steps c through e.
  - g. Once the tension is set correctly, tighten screws (A) and (2).
  - h. Reinstall the hose reel to the mounting location and connect the inlet hose.
  - i. Test for leaks by slowly applying fluid pressure.



# Recycling and Disposal

## End of Product Life

At the end of the product's useful life, dismantle and recycle it in a responsible manner.

- Perform the **Pressure Relief Procedure**.
- Drain and dispose of fluids according to applicable regulations. Refer to the material manufacturer's Safety Data Sheet.
- Deliver remaining product to a recycling facility.

## California Proposition 65

### CALIFORNIA RESIDENTS

 **WARNING:** Cancer and reproductive harm – [www.P65warnings.ca.gov](http://www.P65warnings.ca.gov).

# Graco Information

For the latest information about Graco products, visit [www.graco.com](http://www.graco.com).

For patent information, see [www.graco.com/patents](http://www.graco.com/patents).

**TO PLACE AN ORDER**, contact your Graco distributor or call to identify the nearest distributor.

**Phone:** 612-623-6928 **or Toll Free:** 1-800-533-9655, **Fax:** 612-378-3590

*All written and visual data contained in this document reflects the latest product information available at the time of publication.  
Graco reserves the right to make changes at any time without notice.*

Original instructions. This manual contains English. MM 3A8689

**Graco Headquarters:** Minneapolis

**International Offices:** Belgium, China, Japan, Korea

**GRACO INC. AND SUBSIDIARIES • P.O. BOX 1441 • MINNEAPOLIS MN 55440-1441 • USA**  
**Copyright 2021, Graco Inc. All Graco manufacturing locations are registered to ISO 9001.**

[www.graco.com](http://www.graco.com)  
Revision A, September 2021