

Instructions



SDX™ and XDX™ 10/20 Series Hose Reels

3A8626G

EN

For dispensing air, water, antifreeze, windshield washer solvent, transmission fluid, oil, and grease. Not for use with gasoline or diesel fuels. For professional use only.

Not approved for use in European explosive atmosphere locations.

Model:

See page 3 for model information, including maximum working pressure and approvals.



Important Safety Instructions

Read all warnings and instructions in this manual before using the equipment. Save these instructions.

SDX Series

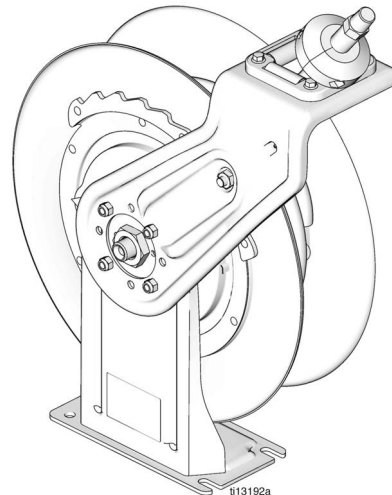

XDX Series

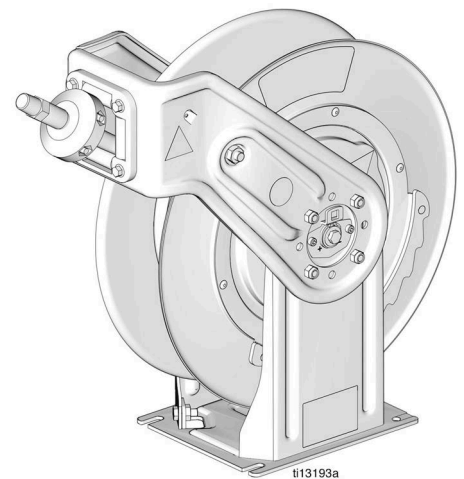

Related Manuals

Manual in English	Description
3A8689	Hose Reel Swivel Kit
406801	Latch Kit
313902	Hose Reel Enclosure Retrofit Kit
406741	Hose Inlet Kit
406743	Roller Guide Kits
406742	Ball Stop Kit



Contents

Related Manuals	1	Repair	23
Models	3	Replace Spool - Single Pedestal SDX Models. . .	23
SDX Series.....	3	Replace Spool - Dual Pedestal XDX Models . . .	24
XDX Series.....	4	Replace the Hose.....	26
Warnings	5	Parts	28
Typical Installation	7	SDX Models.....	28
Overhead-Mounted Hose Reel.....	7	Parts SDX Series.....	29
Installation	8	XDX Models.....	30
Grounding.....	8	Parts XDX Series.....	31
Required Components.....	8	Kits	32
Pressure Relief Procedure.....	9	Hose Reel Label.....	33
Flush the Equipment.....	9	Label, Fluid Identification: 24A223.....	34
Installation Mounting Options.....	11	Latch Kit: 15Y503.....	34
Reel Bank Mounting Location's Selection .	11	Enclosure Retrofit Kit: 24C100.....	34
All Mountings.....	11	Hose Inlet Kit.....	35
All Models.....	12	Mounting Adapter: 24A224.....	35
SDX or XDX Models Only.....	12	Hose Guide Kits.....	35
Ceiling Installations.....	14	Roller Bracket Repair: 218591.....	35
Ceiling Mount Without an I-Beam - Open		Cabinet Mounting Kit: 15Y478.....	35
Channel (All Models).....	15	Hose Reel Stop Kit.....	35
Ceiling Mount Directly to an I-Beam without		1/4 in. and 3/8 in. ID Hoses: 218340.....	35
Drilling holes - All Models.....	16	3/8 in. and 1/2 in. ID Hoses: 218341.....	35
MOUNTING BRACKET KIT: 204741.....	16	1/4 in. ID Hoses: 222225.....	35
Wall Installations.....	17	Dimensions	36
Hose Installation.....	18	SDX Models.....	36
Installation of Hose on a Bare Reel.....	18	XDX Models.....	37
Adjust Spring Tension.....	20	Mounting Channel Dimensions.....	38
Single Pedestal SDX Model Hose Reels . . .	20	Side Dimension (All Models).....	43
Dual Pedestal XDX Model Hose Reels . . .	20	Technical Specifications	44
Recycling and Disposal	21	California Proposition 65	45
End of Product Life.....	21	Graco 7-Year Hose Reel Warranty	46
Troubleshooting	22		

Models

SDX Series

(Part List page 29)

*Each SDX Model hose reel shown in the table is available in several colors. The last character of each Model No. indicates the hose reel color. For example: A = white, B = metallic blue, C = red, D = black, F = yellow.

The SDX Series Models table uses the generic # symbol to represent the last character. For example, to order a white SDL56# model reel hose, the # symbol is replaced with "A" - SDL56A would be the complete model number used.

Model No.*	Size	Type	Maximum Working Pressure psi (MPa, bar)	Media	Connection Size		Line Size (in.)	Length (ft)
					Inlet	Outlet		
SDL6D#	20	Bare	300 (2.1, 21)	Air/Water	1/2 NPSM(m)	1/2 NPSM(f)	1/2	50
SDL23#	10	Hose	300 (2.1, 21)	Air/Water	1/2 NPSM(m)	3/8 NPT(m)	3/8	35
SDL25#	10	Hose	300 (2.1, 21)	Air/Water	1/2 NPSM(m)	3/8 NPT(m)	3/8	50
SDL56#	20	Hose	300 (2.1, 21)	Air/Water	1/2 NPSM(m)	3/8 NPT(m)	3/8	65
SDL33#	10	Hose	300 (2.1, 21)	Air/Water	1/2 NPSM(m)	1/2 NPT(m)	1/2	35
SDL65#	20	Hose	300 (2.1, 21)	Air/Water	1/2 NPSM(m)	1/2 NPT(m)	1/2	50
SDM6D#	20	Bare	2000 (14, 138)	Oil	1/2 NPSM(m)	1/2 NPSM(f)	1/2	50
SDM33#	10	Hose	2000 (14, 138)	Oil	1/2 NPSM(m)	1/2 NPT(m)	1/2	35
SDM65#	20	Hose	2000 (14, 138)	Oil	1/2 NPSM(m)	1/2 NPT(m)	1/2	50
SDM6H#	20	Hose	2000 (14, 138)	Oil	1/2 NPSM(m)	1/2 NPT(m)	1/2	50
SDH5D#	20	Bare	5000 (35, 345)	Grease	3/8 NPSM(m)	3/8 NPSM(f)	3/8	50
SDH55#	20	Hose	5000 (35, 345)	Grease	3/8 NPSM(m)	1/4 NPT(m)	3/8	50

XDX Series

(Part List page 31)









*Each XDX™ Model hose reel shown in the table is available in several colors. The last character of each Model No. indicates the hose reel color. For example: A = white, B = metallic blue, D = Black, F = yellow.

The XDX Models table uses the generic # symbol to represent the last character. For example, to order a white XDL2D# model reel hose, the # symbol is replaced with "A" - XDL2DA would be the complete model number used.





Model No.*	Size	Type	Maximum Working Pressure psi (MPa, bar)	Media	Connection Size		Line Size (in.)	Length (ft)
					Inlet	Outlet		
XDL6D#	20	Bare	300 (2.1, 21)	Air/Water	1/2 NPSM(m)	1/2 NPSM(f)	1/2	50
XDL56#	20	Hose	300 (2.1, 21)	Air/Water	1/2 NPSM(m)	3/8 NPT(m)	3/8	65
XDL65#	20	Hose	300 (2.1, 21)	Air/Water	1/2 NPSM(m)	1/2 NPT(m)	1/2	50
XDM6D#	20	Bare	2000 (14, 138)	Oil	1/2 NPSM(m)	1/2 NPSM(f)	1/2	50
XDM65#	20	Hose	2000 (14, 138)	Oil	1/2 NPSM(m)	1/2NPT(m)	1/2	50
XDH5D#	20	Bare	8000 (55, 552)	Grease	3/8 NPSM(m)	3/8 NPSM(f)	3/8	50
XDH55#	20	Hose	5000 (35, 345)	Grease	3/8 NPSM(m)	1/4 NPT(m)	3/8	50

Warnings

The following warnings are for the setup, use, grounding, maintenance, and repair of this equipment. The exclamation point symbol alerts you to a general warning and the hazard symbols refer to procedure-specific risks. When these symbols appear in the body of this manual or on warning labels, refer back to these Warnings. Product-specific hazard symbols and warnings not covered in this section may appear throughout the body of this manual where applicable.

 <h1 style="margin: 0;">WARNING</h1>	
    	<p>SKIN INJECTION HAZARD</p> <p>High-pressure fluid from dispensing device, hose leaks, or ruptured components will pierce skin. This may look like just a cut, but it is a serious injury that can result in amputation. Get immediate surgical treatment.</p> <ul style="list-style-type: none"> • Do not point dispensing device at anyone or at any part of the body. • Do not put your hand over the fluid outlet. • Do not stop or deflect leaks with your hand, body, glove, or rag. • Follow the Pressure Relief Procedure when you stop dispensing and before cleaning, checking, or servicing equipment. • Tighten all fluid connections before operating the equipment. • Check hoses and couplings daily. Replace worn or damaged parts immediately.
 	<p>FIRE AND EXPLOSION HAZARD</p> <p>When flammable fluids are present in the work area, such as gasoline and windshield wiper fluid, be aware that flammable fumes can ignite or explode. To help prevent fire and explosion:</p> <ul style="list-style-type: none"> • Use equipment only in well-ventilated area. • Eliminate all ignition sources, such as cigarettes and portable electric lamps. • Ground all equipment in the work area. • Keep work area free of debris, including rags and spilled or open containers of solvent and gasoline. • Do not plug or unplug power cords or turn lights on or off when flammable fumes are present. • Use only conductive hoses. • Stop operation immediately if static sparking occurs or you feel a shock. Do not use equipment until you identify and correct the problem. • Keep a working fire extinguisher in the work area.

WARNING

 	<p>EQUIPMENT MISUSE HAZARD Misuse can cause death or serious injury.</p> <ul style="list-style-type: none"> • Do not operate the unit when fatigued or under the influence of drugs or alcohol. • Do not exceed the maximum working pressure or temperature rating of the lowest rated system component. See Technical Specifications in all equipment manuals. • Use fluids and solvents that are compatible with equipment wetted parts. See Technical Specifications in all equipment manuals. Read fluid and solvent manufacturer’s warnings. For complete information about your material, request Safety Data Sheets (SDSs) from distributor or retailer. • Turn off all equipment and follow the Pressure Relief Procedure when equipment is not in use. • Check equipment daily. Repair or replace worn or damaged parts immediately with genuine manufacturer’s replacement parts only. • Do not alter or modify equipment. Alterations or modifications may void agency approvals and create safety hazards. • Make sure all equipment is rated and approved for the environment in which you are using it. • Use equipment only for its intended purpose. Call your distributor for information. • Route hoses and cables away from traffic areas, sharp edges, moving parts, and hot surfaces. • Do not kink or over bend hoses or use hoses to pull equipment. • Keep children and animals away from work area. • Comply with all applicable safety regulations.
 	<p>MOVING PARTS HAZARD Moving parts can pinch, cut or amputate fingers and other body parts.</p> <ul style="list-style-type: none"> • Keep clear of moving parts. • Do not operate equipment with protective guards or covers removed. • Equipment can start without warning. Before checking, moving, or servicing equipment, follow the Pressure Relief Procedure and disconnect all power sources.
	<p>PERSONAL PROTECTIVE EQUIPMENT Wear appropriate protective equipment when in the work area to help prevent serious injury, including eye injury, hearing loss, inhalation of toxic fumes, and burns. Protective equipment includes but is not limited to:</p> <ul style="list-style-type: none"> • Protective eyewear, and hearing protection. • Respirators, protective clothing, and gloves as recommended by the fluid and solvent manufacturer.

Typical Installation

Overhead-Mounted Hose Reel

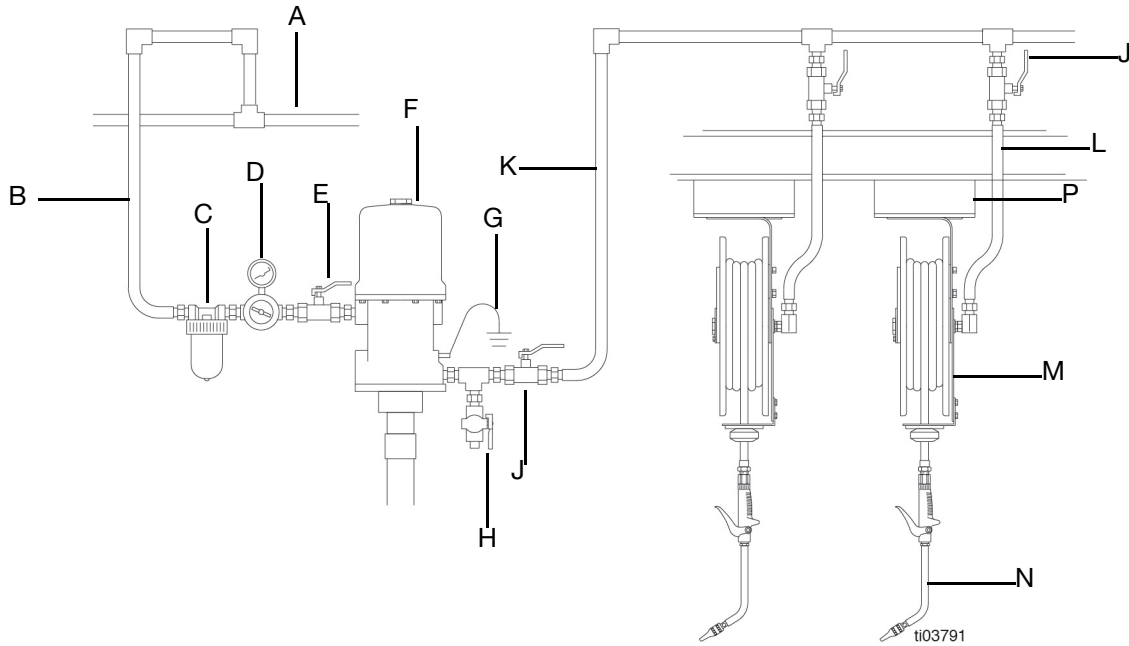
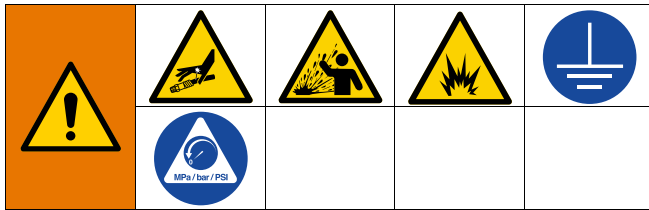

FIG. 1: Typical Installation

Key:

- A Main Air Supply Line
- B Pump Air Supply Line
- C Air Filter
- D Air Regulator
- E Bleed-type Master Air Valve (required)
- F Pump
- G Pump Grounding Wire (required)
- H Fluid Drain Valve (required)
- J Fluid Shutoff Valve
- K Fluid Line
- L Hose Inlet Kit
- M Hose Reel
- N Dispense Valve
- P Mounting Channel/Base

Installation



A ground wire (G), bleed-type master air valve (E), and fluid drain valve (H) are required in your system installation. These components help reduce the risk of serious injury, including fire and explosion, injection, and splashing in your eyes or on the skin.

- The ground wire must be connected to the pump grounding lug and to a true earth ground according to your local codes.
- The bleed-type master air valve relieves air trapped between this valve and the pump after the air is shut off. Trapped air can cause the pump to cycle unexpectedly. Locate the valve close to the pump.
- The fluid drain valve assists in relieving fluid pressure in the pump, hose, and dispense valve. Triggering the valve to relieve pressure may not be sufficient to relieve pressure when the Fluid Shutoff Valve (J) is closed.

The typical installation shown in FIG. 1 is only a guide for selecting and installing a hose reel system. The components shown are the minimum requirements for all systems. However, it is not an actual system design. Contact your Graco Distributor for assistance in designing a system.

NOTE: The air and fluid accessories required for your pump must be properly sized to the pump. Refer to your pump manual for selecting pump accessories.

Grounding



The equipment must be grounded to reduce the risk of static sparking. Static sparking can cause fumes to ignite or explode. Grounding provides an escape wire for the electric current.

Pump: follow manufacturer’s recommendations.

Hose reels: connect to a true earth ground when dispensing petroleum products. This can be done by bolting the reel to a grounded structure, or by using a conductive inlet hose to connect to a grounded piping system.

Fluid hoses: use only conductive hoses when dispensing petroleum products.

Dispense valves: use thread sealant when connecting the meter to the hose. Do not use PTFE tape on the pipe joints, as it may cause loss of ground across the pipe joint.

Waste container while flushing: use a grounded metal container. Hold the hose coupling or metal part of the meter firmly to the side of the waste container while flushing.

Required Components

Be sure to have the following components before beginning installation.

- Hose Inlet Kits (L)
- Reel mounting bases, mounting brackets, and mounting channels (P)
- Dispense valves (N)

Pressure Relief Procedure



Follow the Pressure Relief Procedure whenever you see this symbol.

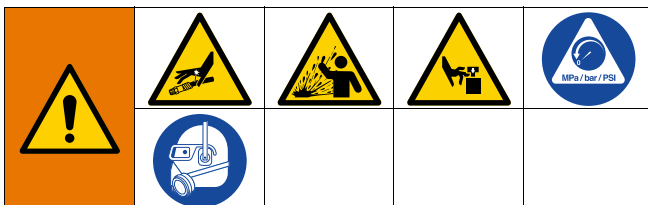

This equipment stays pressurized until pressure is manually relieved. To help prevent serious injury from pressurized fluid, such as skin injection, splashing fluid and moving parts, follow the Pressure Relief Procedure when you stop dispensing and before cleaning, checking, or servicing the equipment.

1. Turn off the power supply to the pump or close the upstream ball valve.
2. Trigger the dispense valve into a waste container to relieve pressure.
3. Open any bleed-type master air valves and fluid drain valves in the system.
4. Leave the drain valve open until ready to pressurize the system.

NOTE: If you suspect that the dispense valve or extension is clogged, or that the pressure has not been fully relieved after following the above steps, very slowly loosen the coupler or hose end coupling to relieve the pressure gradually, then loosen completely. After doing this, the obstruction can be cleared.

Flush the Equipment



To avoid fire and explosion, always ground equipment and waste container. To avoid static sparking and injury from splashing, always flush at the lowest possible pressure.

Before installation of the dispense valve to the end of the hose, flush the line with the fluid being dispensed.

1. Place the end of the hose into a grounded metal waste container. Hold the hose firmly against the waste container throughout the flushing process (FIG. 2).

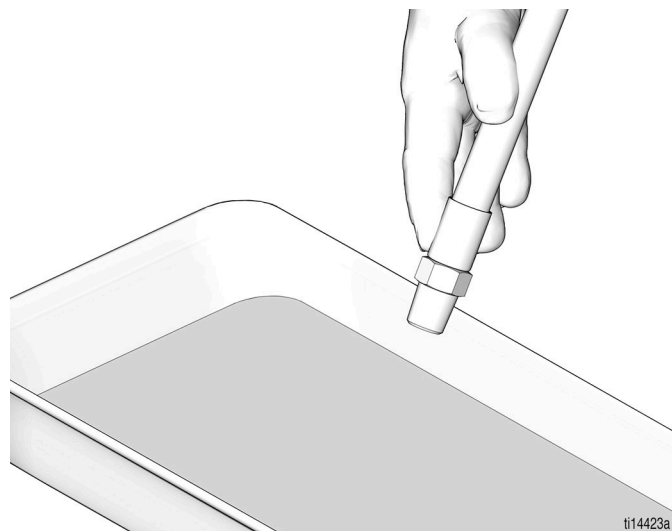

FIG. 2

ti14423a

Installation

2. Blow out the entire lubricant supply line with air (FIG. 3).

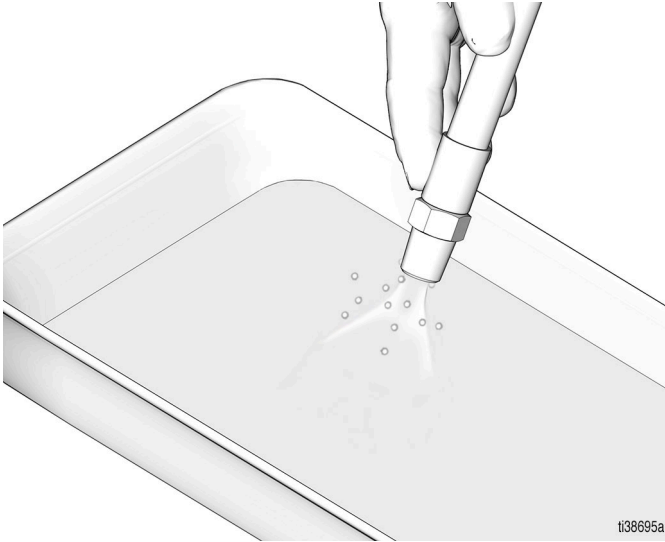

FIG. 3

3. Flush the fluid being dispensed through the equipment until the fluid runs clear (FIG. 4).

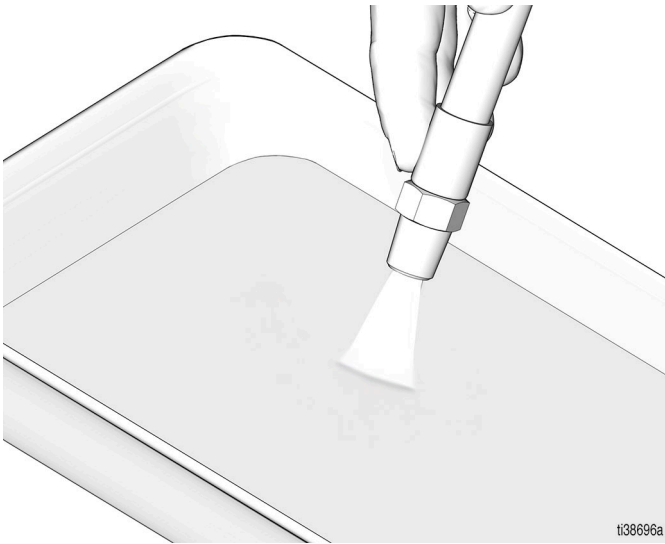

FIG. 4

Installation Mounting Options

Reel Bank Mounting Location's Selection

A Mounting Adapter Kit is available for installing an XDX Series Hose Reel in the same location that a Series 500 Hose Reel was previously installed. Graco Kit No. 24A224. See FIG. 5, and page 35.

A = Original Series 500 holes in mounting surface.

B = Holes on the bottom of the adapter bracket, pre-drilled to match the Original Series 500 hole configuration (A).

C = Holes on the top of the adapter bracket, pre-drilled to match the new XDX Series Hose Reel base.

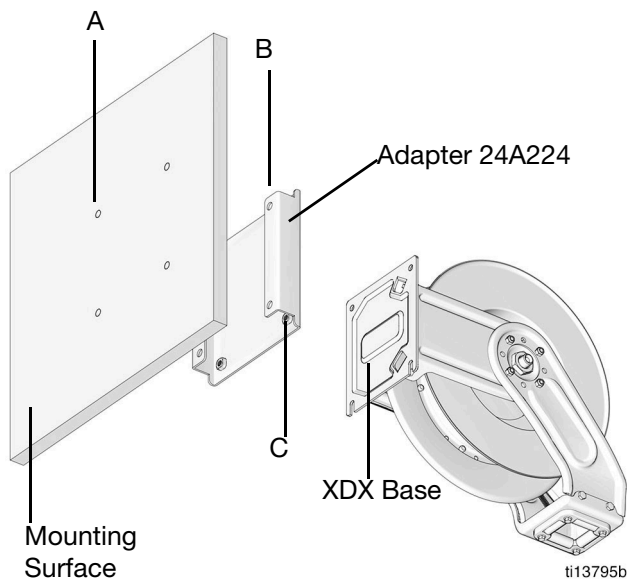

FIG. 5

All Mountings



To reduce the risk of injury, be sure that the mounting surface is strong enough to support the reels, weight of the lubricants, and the stress caused by hard pulls on the hoses. See **Technical Specifications**, page 44, for weights of the hose reel assemblies.

NOTE: Always use all four (4) large flat washers with four (4) bolts to mount the hose reel pedestal to any surface.

NOTE: The reels perform best when the arm allows the hose to pull straight off of the spool (FIG. 6).

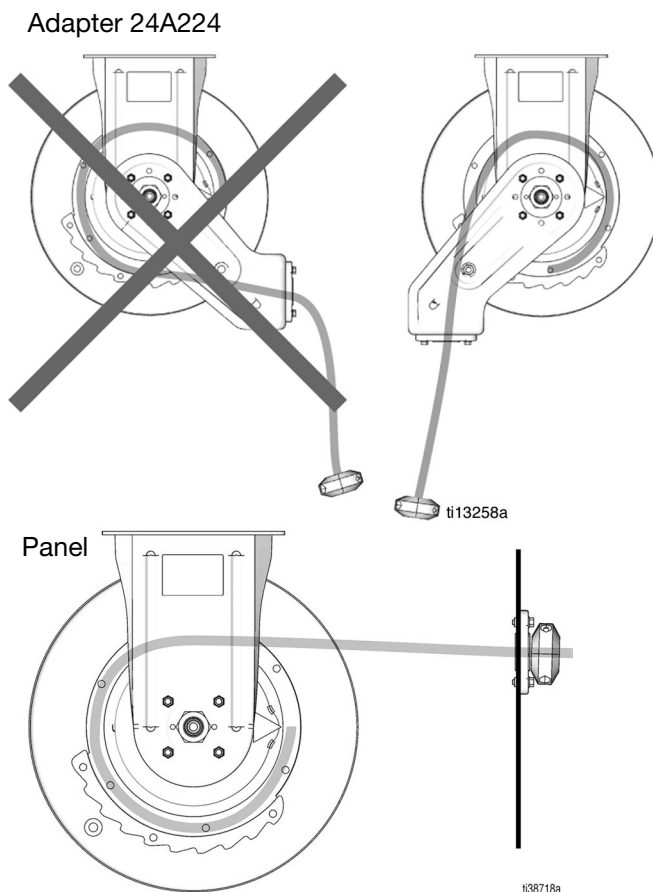

FIG. 6

All Models

Select the reel bank mounting location (FIG. 7).

- For high ceilings, suspend a suitable support structure for the reels, so the hoses will be long enough to reach the service area.
- A reel bank mounted in a one-lift service bay should be at least 6 ft (1.9 m) from the center line of the lift.
- A reel bank mounted in a two-lift service bay should be mounted an equal distance between the lifts.
- A bank of all motor oil reels should be mounted about 5 ft (1.5 m) from the center of the lift, toward the front of the lift rails.

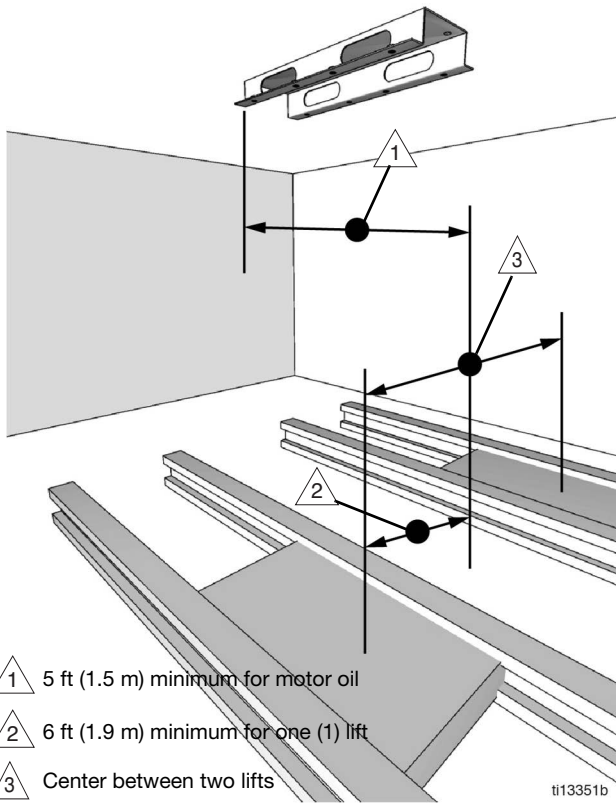

FIG. 7

SDX or XDX Models Only

NOTE: The reference letters in the following instructions refer to FIG. 8 and FIG. 26.

1. Determine if the position of the roller guide arm (a) (FIG. 8) is in the desired installation position. If it is not in the desired installation position, skip to Step 2.

The hose reel is factory-assembled and shipped with the roller guide arm (a) in either the AA or EE position (FIG. 8).

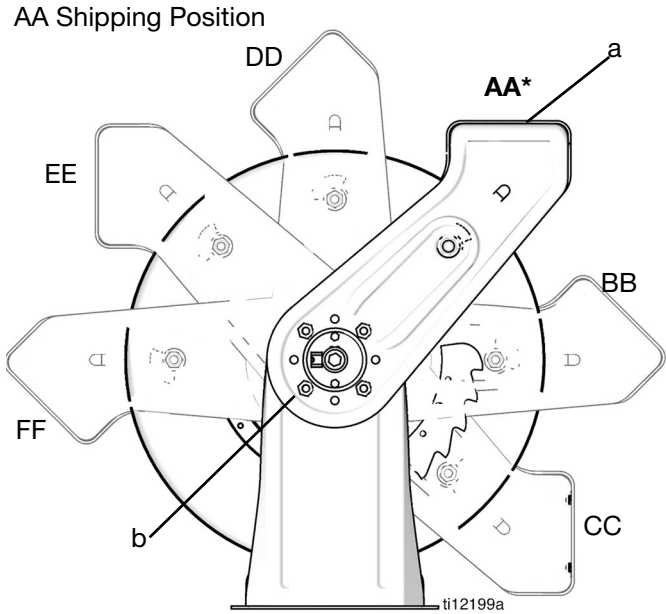

*SDX Models are shipped with the roller guide arm (a) in the AA position.

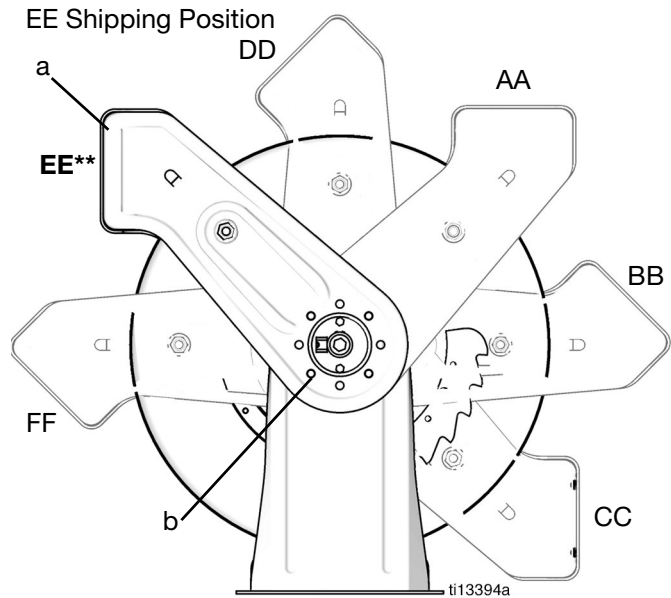

**All XDX Models are shipped with the roller guide arm (a) in the EE position.

FIG. 8

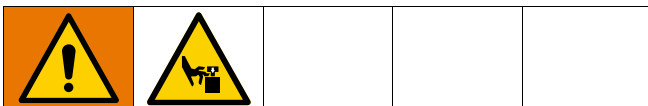

2. To reposition the roller guide arm (a) to a position other than Shipping Position AA or EE:
 - a. Secure the reel to a solid surface with C-clamps (C) (FIG. 9).
 - b. Attach a C-clamp (D) to the reel flange to prevent the reel from unintentionally becoming unlatched and spinning freely (FIG. 9).

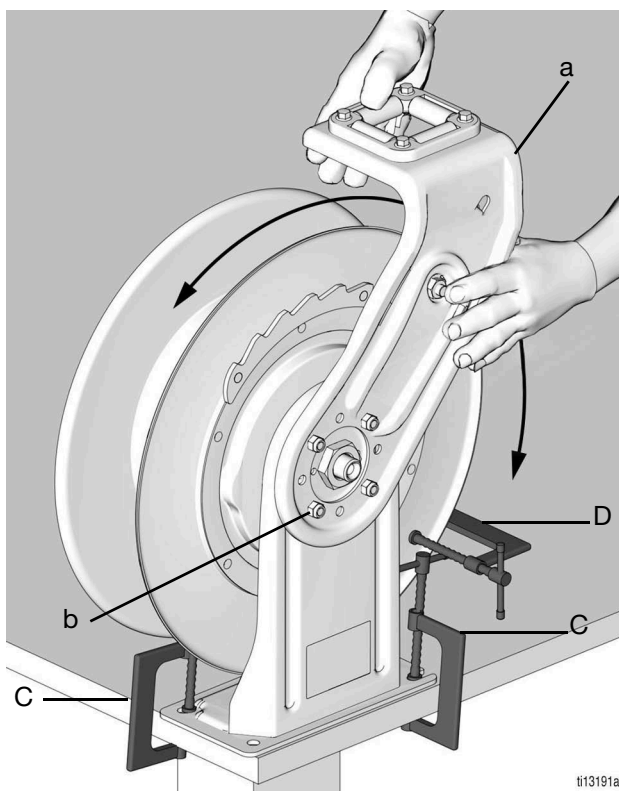

FIG. 9

- c. Remove the nuts (b) from each side and rotate arm (a) to the desired position.

NOTE: SDX Model Reels have four (4) nuts, and XDX Model Reels have eight (8) nuts (four on each side).

- d. Check the pawl to make sure it is not wedged (FIG. 10).

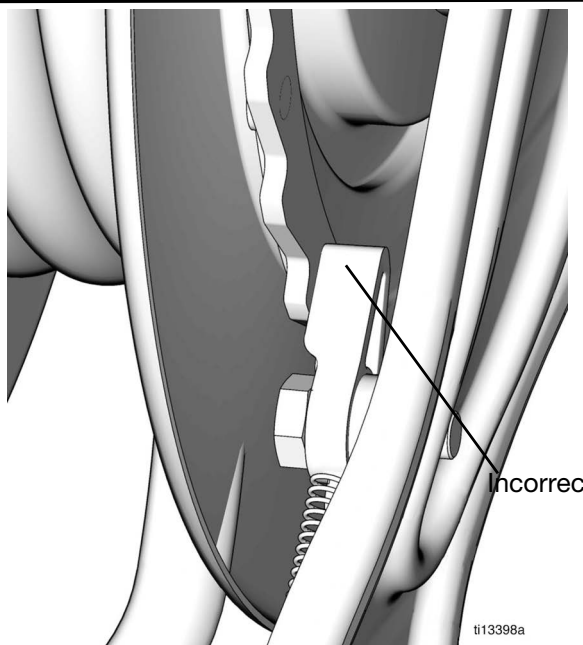
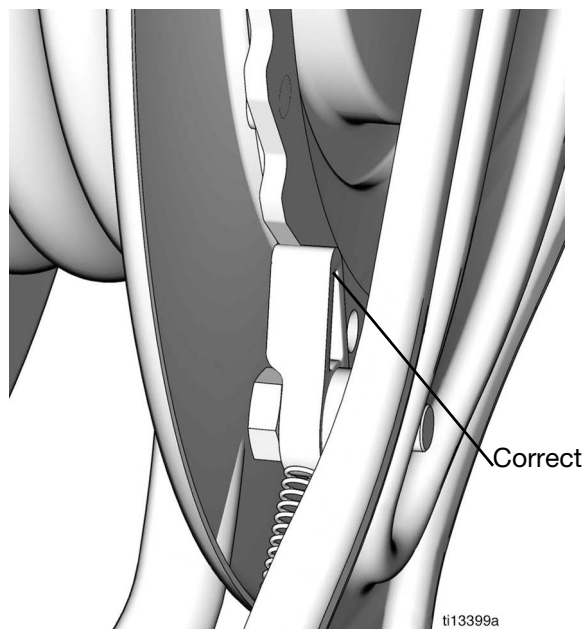
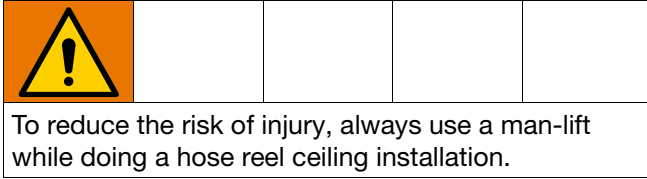

FIG. 10

- e. Replace and tighten nuts to secure the arm (torque 25 - 35 ft-lb/33.9 - 47.5 N•m).

Ceiling Installations



XDX Models Only

1. Reposition the guide arm to position AA. See Step 2, page 13.
2. Position the hose reel so the pedestal is facing upward.
3. Using the man-lift, raise the reel as close to the mounting location as possible.
4. Bolt the hose reel to the mounting, making sure that it is secure before lowering the man-lift.
5. Connect the inlet supply line to the inlet hose of the reel. See **Hose Installation**, page 18.

NOTE: None of the hose reels listed in this manual come with a Hose Inlet Kit.

6. Flush the hose following the instructions in **Flush the Equipment**, page 9.
7. Re-position the hose stop, if needed, so that the hose extends far enough for all operators to reach the dispense valve, then tighten the nuts to securely hold the hose stop in place.

8. Install the motor or dispense valve to the end of the hose following the instructions provided with the dispense equipment.

NOTE: if an enclosure is being installed around the hose reel, first install the dispense valve or motor to the hose end.

9. See **Adjust Spring Tension**, page 20.

Ceiling Mount Without an I-Beam - Open Channel (All Models)

- For SDX Model Reels Order Mounting Kit: 24A934, 24A935, 24A936, 24A937, 24A938, or 24A939.
- For XDX Model Reels Order Mounting Kit: 24A219, 24A220, 24A221, or 24A222.
- See Mounting Channel Dimensions, page 38.

SDX Models: Open Channel Mounting Kits								XDX Models: Mounting Kits			
FN	Description	24A934 1 Reel	24A935 2 Reels	24A936 3 Reels	24A937 4 Reels	24A938 5 Reels	24A939 6 Reels	24A219 1 Reel	24A220 2 Reels	24A221 3 Reels	24A222 6 Reels
101	PLATE, hold down	1	2	3	4	5	6				
102	SCREW, 3/8 in. -16 x 5/8 in.	5	10	15	20	25	30	4	8	12	24
103	WASHER, lock, 3/8 in.	5	10	15	20	25	30	4	8	12	24
104	BASE, reel	1	2	3	4	5	6				
105	BASE, reel, channel	1	1	1	1	1	1	1	1	1	1

1. Install the mounting channel (105) and base plate (104) (SDX Models), as shown in FIG. 11.



2. Slide the hose reel into the base plate (104) and install the hold down plate (101), washer (103), and the cap screw (102). Tighten the screw firmly (FIG. 11).

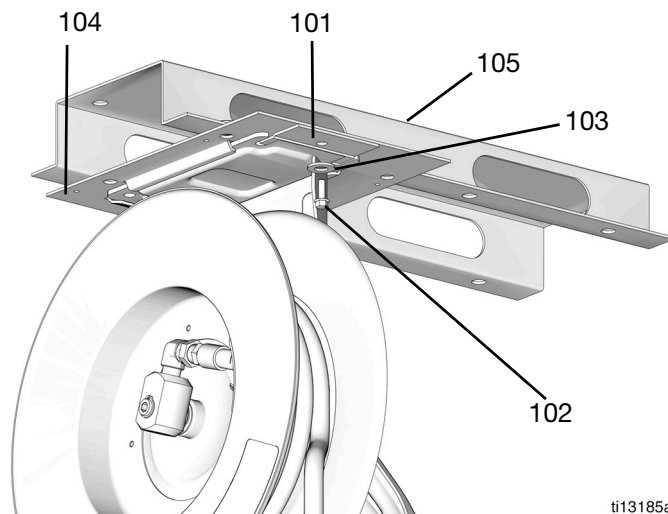

FIG. 11

3. When installing permanent supply lines above the ceiling, drill 1.5 in. (38 mm) diameter holes through the ceiling toward the inlet side of the reels.
4. Follow Steps 5 through 9, **Ceiling Installations**, page 14 to complete installation.

Ceiling Mount Directly to an I-Beam without Drilling holes - All Models

NOTE: Order Mounting Bracket Kit: 204741 for open or enclosed reels.

NOTE:

- Two kits are required when mounting one to three reels.
- Three kits are required when mounting four to six reels.



MOUNTING BRACKET KIT: 204741

FN	Description	Qty
201	WASHER, lock, 1/2 in.	4
202	SCREW, 1/2 in. - 13 x 1 in.	2
203	SCREW, 1/2 in. 13 x 3/4 in.	2
204	NUT, 1/2 in. - 13	2
205	NUT, spring clamp (not shown)	2
206	CLAMP, beam	2
207	CHANNEL, strut	1

1. Secure mounting brackets (D) to the channel. Use two mounting brackets for each one to three capacity mounting channel (105). Use three mounting brackets for each four to six capacity mounting channel (105).
2. Position the adjustable clamps (206) for the mounting brackets over the I-Beam (A), then tighten securely (FIG. 12).
3. SDX Model Reels only: See FIG. 11, page 15. Slide the hose reel onto the base plate (104) then install the hold down plate (101), washer (103), and cap screw (102). Tighten the screw firmly.
4. If installing permanent supply lines above a ceiling, drill 1.5 in. (38 mm) diameter holes through the ceiling toward the inlet side of the reels.
5. Connect the inlet supply line to the inlet hose of the reel. See **Hose Installation**, page 18.

NOTE: The hose reels listed in this manual do not come with a Hose Inlet Kit.

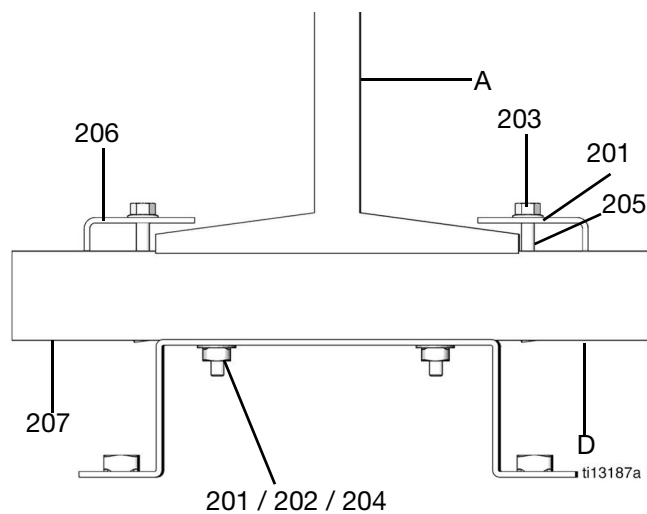
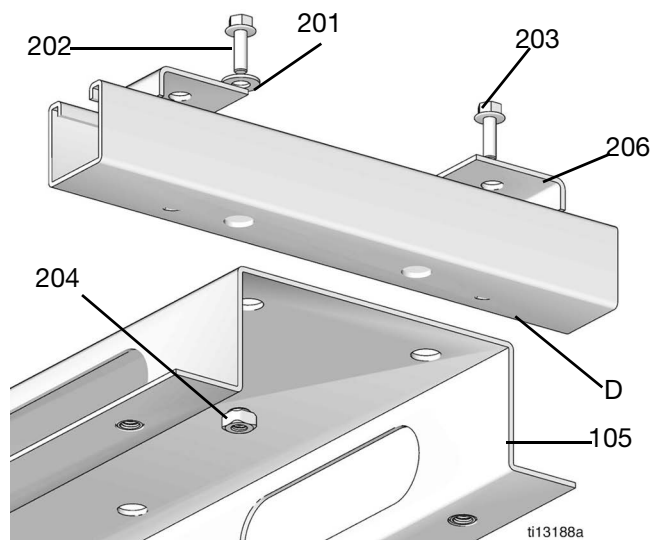

FIG. 12

6. Flush the hose following the instructions in **Flush the Equipment**, page 9.

Wall Installations



- For SDX Model Reels Wall Mounting Bracket Kit With No Channel order: 24H193.

- For SDX Model Reels Open Channeling Mounting Kit order: 24A934, 24A935, 24A936, 24A937, 24A938, or 24A939.
- For XDX Model Reels Mounting Kit order: 24A219, 24A220, 24A221, or 24A222.

SDX Models: Open Channel Mounting Kits								XDX Models: Mounting Kits			
FN	Description	24A934 1 Reel	24A935 2 Reels	24A936 3 Reels	24A937 4 Reels	24A938 5 Reels	24A939 6 Reels	24A219 1 Reel	24A220 2 Reels	24A221 3 Reels	24A222 4 Reels
101	PLATE, hold down	1	2	3	4	5	6				
102	SCREW, 3/8 in. -16 x 5/8 in.	5	10	15	20	25	30	4	8	12	24
103	WASHER, lock, 3/8 in.	5	10	15	20	25	30	4	8	12	24
104	BASE, reel	1	2	3	4	5	6				
105	BASE, reel, channel	1	1	1	1	1	1	1	1	1	1

1. Adjust the guide arm to the desired position, see FIG. 8, page 12.
2. Select the wall mounting location and style for the reel bank.

NOTE: The base plate (104) can be directly mounted to the wall for easier installation and removal of the hose reel for servicing (FIG. 13).

- a. For mounting the reel directly to the wall, use the provided template (B) to lay out the holes for drilling (FIG. 13).
- b. For mounting with Kit 24H193, mount the base plate (104) to the wall, slide the hose reel onto the base plate (104), then install the hold down plate (101), the washer (103), and the cap screw (102). Tighten the screw firmly (FIG. 13).
- c. For mounting with Kits 24A934-24A939, mount the channel (105) to the wall, mount the base plate (104) to the channel (105), slide the hose reel onto the base plate (104), then install the hold down plate (101), the washer (103), and the cap screw (102). Tighten the screw firmly (FIG. 13).

- d. For mounting with Kits 24A219-24A222, mount the channel (105) to the wall, then mount the hose reel to the channel (105) (FIG. 14).

3. Slide the hose reel onto the base plate (104) then install the hold down plate (101), washer (103), and cap screw (102). Tighten the screw firmly (FIG. 13).

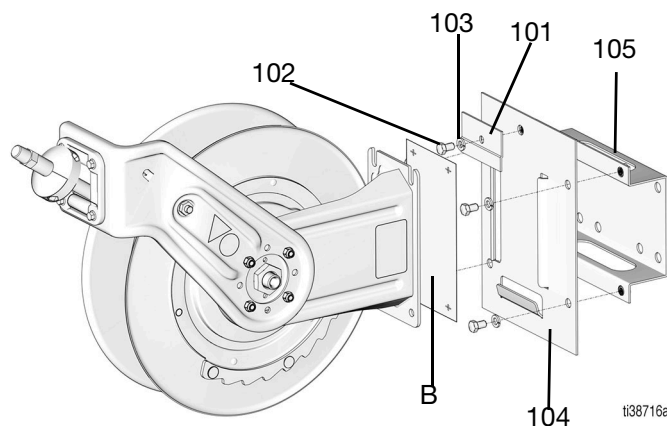
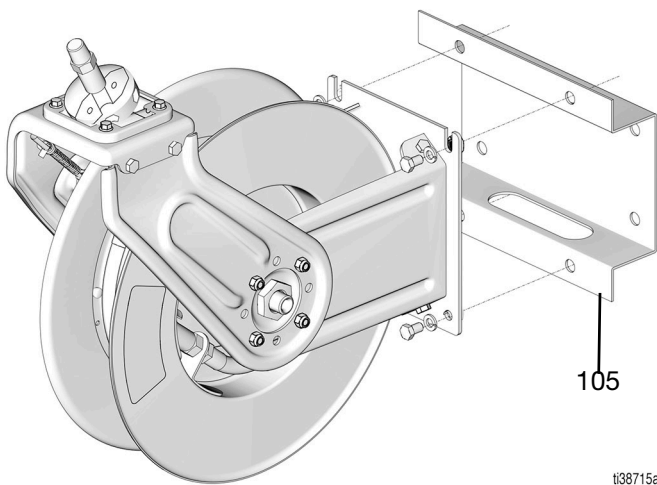

FIG. 13



ti38715a

FIG. 14

4. Connect the supply line to the hose reel inlet using the hose inlet kit (see **Typical Installation**, FIG. 1, page 7).

NOTE: The hose reels listed in this manual do not come with a Hose Inlet Kit.

5. Flush the hose following the instructions in **Flush the Equipment**, page 9.

Hose Installation

Installation of Hose on a Bare Reel

1. Locate the length of the hose in the table and note the number of revolutions the spool must be turned to properly pre-set the spring tension.

Hose Length	No. of Spool Turns
35 ft (10.7 m)	17
50 ft (15.2 m)	21
65 ft (19.8 m)	23



SPRING TENSION HAZARD

The hose reel spring is always under great tension, which if released in an uncontrolled manner could cause serious injury.

- Never allow the reel to spin freely. Uncontrolled spinning could cause serious injury if hit by the hose.
- Securely fasten the reel in place while making adjustments.
- The hose reel spring is not a serviceable part. Do not attempt to replace or service the hose reel spring.
- Always wear heavy gloves while adjusting the spring tension to protect your hands from being cut on the hose reel.

2. Secure the reel to a solid surface with C-clamps (C) (FIG. 9)
3. Place a piece of tape on the side of the reel flange as a visual reference to count the number of revolutions.

4. While wearing heavy gloves, firmly grasp the outside edge of the reel flange with both hands. Wind the spool the correct number of turns (see reference table from Step 1), rotating the reel in the direction shown in FIG. 15.
- Stop only at latching locations.
 - Stop the reel where there is access to the hose swivel (A) (FIG. 16), and where the reel is securely latched.
5. Before installation of the hose, attach a C-clamp (D, FIG. 15) to the reel flange to prevent the reel from unintentionally becoming unlatched and spinning freely.

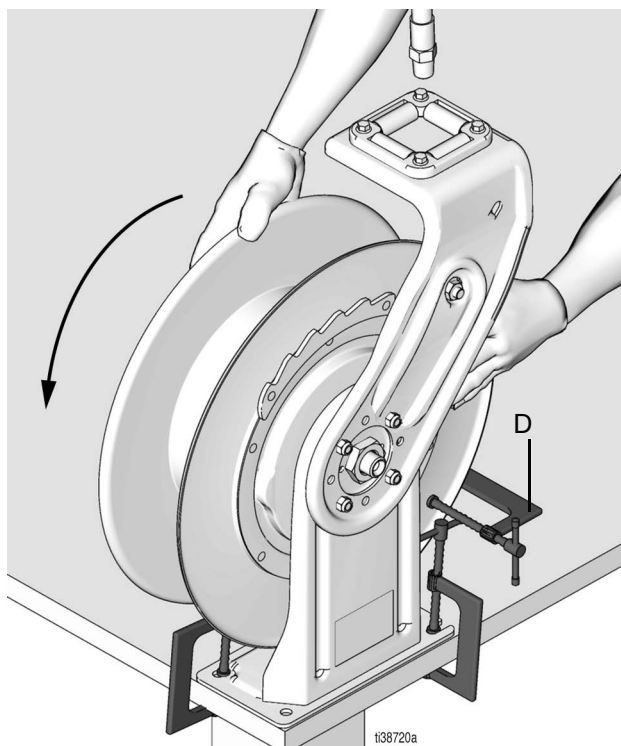

FIG. 15

6. Uncoil and extend the hose.
7. Install the hose stop (C) (FIG. 16) to the end of the hose. If the hose has a warning tag (F), the hose stop should be installed on the same end of the hose as the warning tag.

NOTE: If the hose is equipped with a spring guard, this end must be on the same end as the hose stop.

8. Run the end of the hose (B) through the hose guide (G) and then to the hole (E) in the reel (FIG. 16).

9. Attach the hose end (B) to the hose reel swivel (A).
10. Carefully remove the C-clamp (D) (FIG. 15),

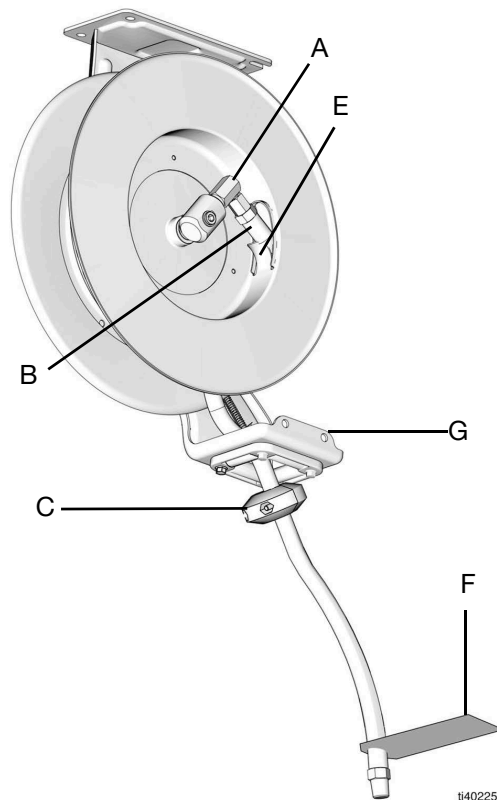

FIG. 16

11. Pull on the hose hard enough to release the latch, and slowly allow the hose to retract.
12. Re-position the hose stop so the hose extends far enough for all operators to reach the dispense valve.
13. Flush the hose following the **Flush the Equipment** instructions, page 9.

Adjust Spring Tension



SPRING TENSION HAZARD

The hose reel spring is always under great tension, which if released in an uncontrolled manner could cause serious injury.

- Never allow the reel to spin freely. Uncontrolled spinning could cause serious injury if hit by the hose.
- Always grasp the adjusting tool firmly with both hands when adjusting tension. Spring tension can cause the tool to move violently.
- Securely fasten the reel in place while making adjustments.
- The hose reel spring is not a serviceable part. Do not attempt to replace or service the hose reel spring.
- Always wear heavy gloves while adjusting the spring tension to protect your hands from being cut on the hose reel.

Single Pedestal SDX Model Hose Reels

Increase Spring Tension

1. Pull the hose out one to two turns, then engage the latch.
2. Pull the hose back through the hose guides.
3. Wrap a loop of hose onto the reel flange.
4. Check the spring tension. The hose must pull out fully and retract fully. Wrap more loops, one at a time around the reel flange, until the spring has the desired tension.

NOTE: Do not put so many loops onto the reel so that the spring winds up tightly before the hose is fully extended.

Decrease Spring Tension

To decrease the spring tension, remove loops around the reel flange until tension is at the desired level.

Dual Pedestal XDX Model Hose Reels

If the hose is not retracting sufficiently, or is wound too tight, the tension can be increased or decreased using one of the following procedures:

Increase Spring Tension

(Spring is too loose, hose does not retract completely, or retraction is sluggish.)

NOTE: The reference letters in the following instructions refer to FIG. 17.

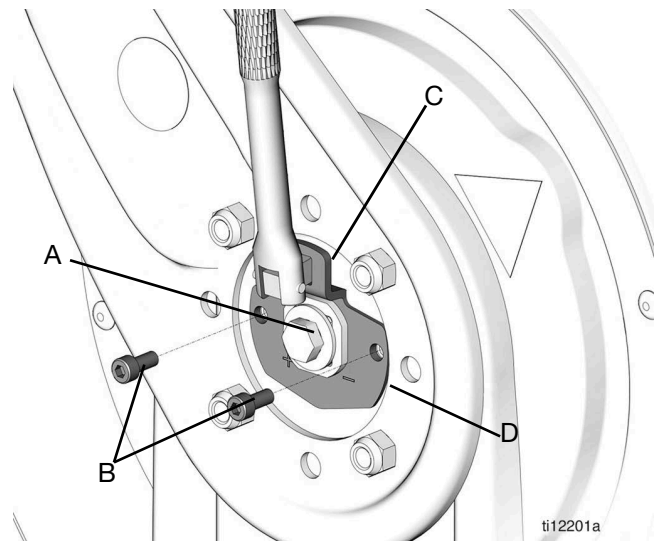

FIG. 17

1. Loosen screw (A) three to five turns. Do not completely remove the screw.
2. Use a hex wrench to loosen the two screws (B). Do not completely remove the screws.
3. Insert a 3/8 in. square drive breaker bar into opening (C) on the spring adjustment plate (D).
4. While holding the breaker bar securely, completely remove the two screws (B).
5. While firmly grasping the breaker bar with both hands, turn the spring adjustment plate clockwise one turn at a time to increase (tighten) the spring tension.
6. Replace and finger-tighten both screws (B).
7. Remove the breaker bar.
8. Pull out a section of hose and allow it to retract to test the tension adjustment.

9. If additional tension is required, repeat steps 3 through 8.
10. When the tension is at the required level, tighten screws A and B.

**Decrease Spring Tension
(Spring is too tight, hose retracts too fast.)**

NOTE: The reference letters in the following instructions refer to FIG. 16 and FIG. 17.

1. Loosen screw (A) three to five turns. Do not completely remove the screw.
2. Use a hex wrench to loosen the two screws (B). Do not completely remove the screws.
3. Insert a 3/8 in. square drive breaker bar into opening (C) on the spring adjustment plate (D).
4. While holding the breaker bar securely, completely remove the two screws (B).
5. While firmly grasping the breaker bar with both hands, turn the spring adjustment plate counter-clockwise one turn at a time to decrease (loosen) the spring tension.
6. Replace and finger-tighten both screws (B).
7. Remove the breaker bar.
8. Pull out a section of hose and allow it to retract to test the tension adjustment.
9. If additional tension is required, repeat steps 3 through 8.
10. When the tension is at the required level, tighten screws A and B.

Recycling and Disposal

End of Product Life

At the end of the product's useful life, dismantle and recycle it in a responsible manner.

- Perform the **Pressure Relief Procedure**, page 9.
- Drain and dispose of fluids according to applicable regulations. Refer to the material manufacturer's Safety Data Sheet.
- Deliver remaining product to a recycling facility.

Troubleshooting

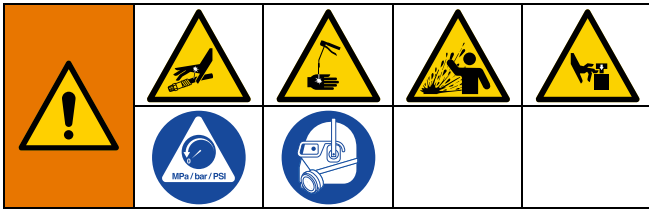

Follow **Pressure Relief Procedure**, page 9, before checking or repairing the equipment.

Check all possible problems and causes before disassembling.

Problem	Cause	Solution
The reel does not retract	Worn or broken spring	Replace spool. See pages 23 - 24.
Oil leaking from hose reel swivel	Worn or damaged swivel seals	Replace swivel. See page 32 to determine the swivel needed. See Hose Reel Swivel Kit Manual for repair information.
Fluid delivery is slow	Pressure setting is too low	Increase pressure
Hose stacks over reel spool	Retracting the hose too quickly; retracting the hose to one side of the guide, allowing the hose to stack off to one side of the spool, and eventually over the spool; allowing the spring to unwind the reel.	Retract the hose slowly, making sure it is centered so that the hose is directly below, or in line, with the hose guide.

Repair

Replace Spool - Single Pedestal SDX Models

A complete list of replacement **Kits** is available on page 32. Use all of the new parts included in the kit.



1. Follow the **Pressure Relief Procedure**, page 9.
2. Completely remove all spring tension. See **Decrease Spring Tension** information, page 20.

NOTE: The reference letters in the following instructions refer to FIG. 18 - FIG. 20.

3. Remove the cap screw (102), washer (103), and the hold-down plate (101).
4. Slide the hose reel out of the base plate (104) (FIG. 18).

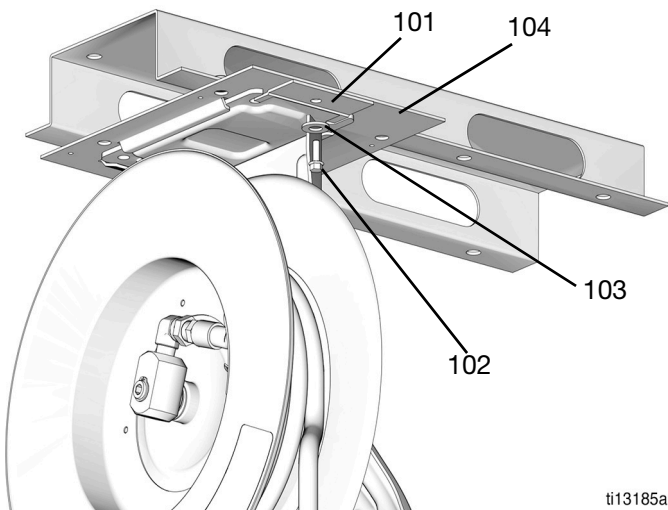

FIG. 18

5. Completely remove the hose from the swivel assembly (6 - contains 6a, 6b, and 6c) and set it aside for re-installation on the new spool (FIG. 19).
6. Loosen and unscrew the swivel shaft (6c) to remove the swivel assembly (6) from the spool (5) (FIG. 19)

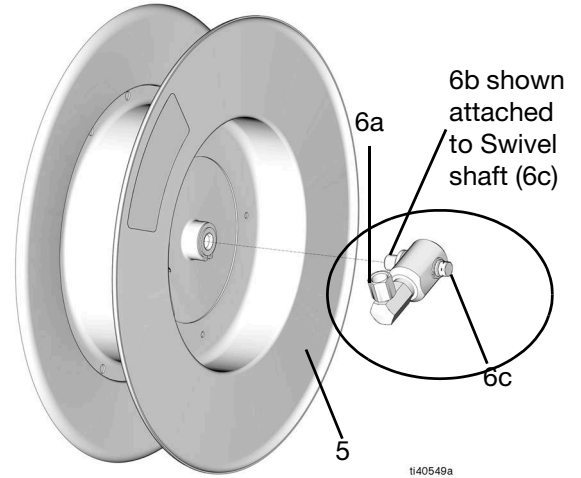

FIG. 19

7. Remove and discard the nut (5g) (FIG. 20).
8. Completely remove, as one piece, the guide arm (18) and pedestal assembly (16) and set it aside for re-installation on the new spool (FIG. 20).

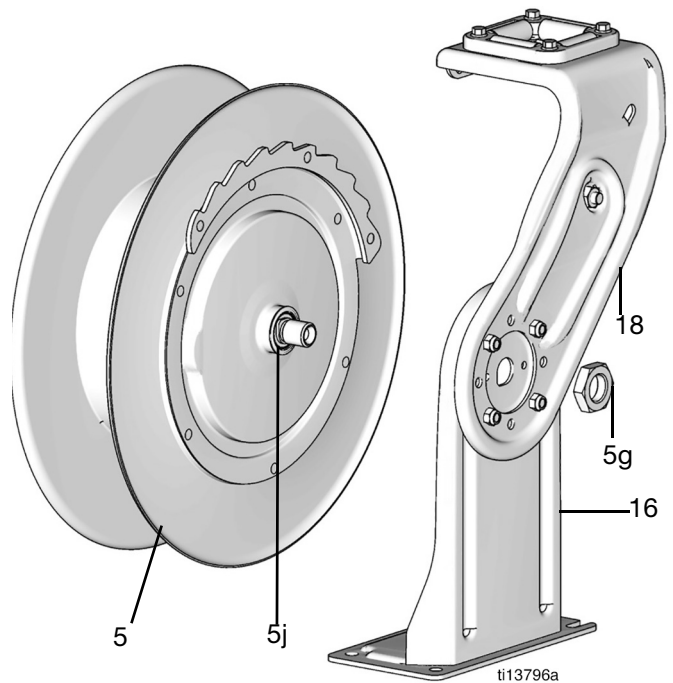

FIG. 20

- Detach the spool assembly (5).

NOTE: Check that the washer (5j) is not adhering to the inside of the pedestal assembly (16). Discard the washer (5j) with the old spool. A new washer (5j) is installed on the new spool (5) and is part of the new spool (5) assembly.

- Install the new spool assembly (5).
- Reinstall the guide arm (18) and pedestal assembly (16) over the spool (5) and install the nut (5g) and tighten (torque 85 - 105 ft-lb/115.2 - 142.4 N•m).
- Ensure that the o-ring (6b) is not damaged, then replace the swivel assembly (6) (torque 25 - 30 ft-lb/33.9 - 40.7 N•m).
- Slide the hose reel onto the base plate (104) and install the hold-down plate (101), the washer (103), and the cap screw (102). Firmly tighten the screw (102).
- Install the hose onto the spool following the **Hose Installation** instructions, page 18.
- Flush the hose following the **Flush the Equipment** instructions, page 9.
- Set the spring tension following the **Adjust Spring Tension** instructions, page 20.

Replace Spool - Dual Pedestal XDX Models

A complete list of replacement **Kits** is available on page 32. Use all of the new parts included in the kit.

When replacing the spool assembly, it is recommended that a Swivel Replacement Kit be ordered. To determine the correct swivel replacement for your reel, see page 32.



- Follow the **Pressure Relief Procedure**, page 9.
- Completely remove all spring tension. See **Decrease Spring Tension** information, page 21.
- Remove the reel from service.
- Completely remove the hose from the spool and set it aside for re-installation on the new spool.
- Remove the large nut (11) (FIG. 21).
- Remove the two screws (27) holding the pedestal (26) to the base (24) and the two screws (27) holding the guide arm (29) to the guide arm (30) (FIG. 21).
- Completely remove, as one piece, the guide arm (29) and pedestal assembly (26) and set it aside for re-installation on the new spool (FIG. 21).

NOTE: These parts do not have to be disassembled.

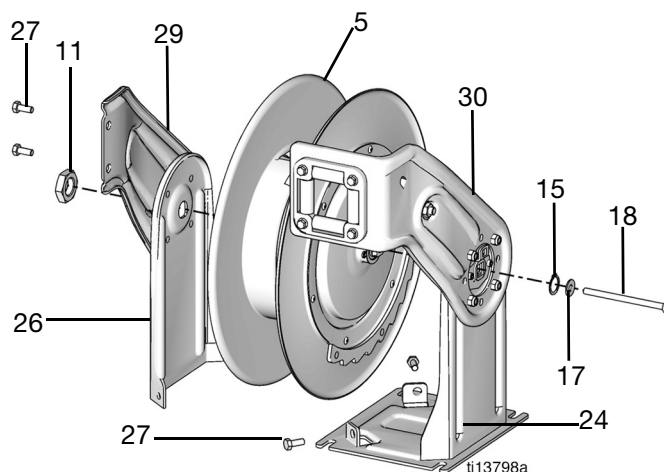

FIG. 21

8. Lay the hose reel on its side to easily access the guide arm (30) and pedestal (24).
9. Remove the long bolt (18) and washers (15 and 17) (FIG. 21).
10. Remove the snap ring (5e) (FIG. 22).

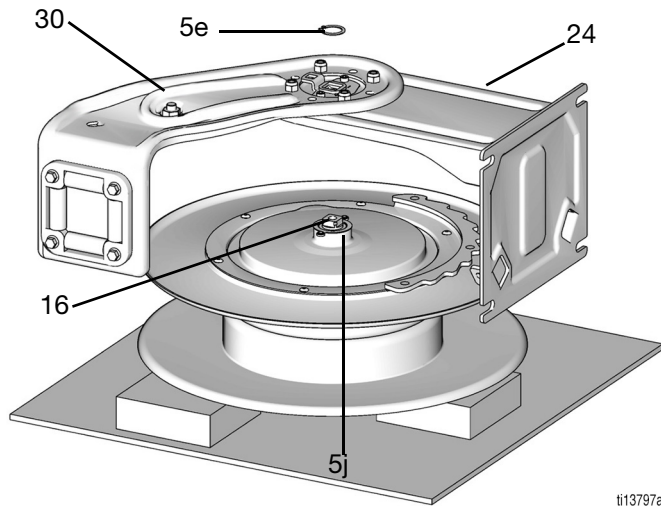

FIG. 22

ti13797a

11. Completely remove, as one piece, the guide arm (30) and pedestal base (24) and set it aside for re-installation on the new spool.

NOTE: These parts do not have to be disassembled.

NOTE: Check that the washer (5j) is not adhering to the inside of the pedestal base (24). Discard the washer (5j) with the old spool. A new washer (5j) is installed on the new spool (5) and is part of the new spool (5) assembly.

12. Discard the old spool.
13. Place the new spool (5) on its side on a work bench, with the flat side of the spool facing downward and the ratchet side facing upward, see FIG. 22.
14. Position the guide arm (30) and pedestal base (24) assembly over the spool. Adjust, as needed, to align the parts.

NOTE: Re-attaching the guide arm (30) and pedestal base (24) assembly is easier when the spool (5) is supported and level. Placing 1 in. (25 mm) scrap wood blocks under the spool, as shown in FIG. 22, supports it during installation of the arm.

15. Replace with a new snap ring (5e).
16. Install the new swivel assembly in the spool. See **Kits**, page 32 for determining the correct Swivel Replacement Kit.

17. Install washers (15 and 17) and the long bolt (18), but do not tighten the bolt.
18. Turn the spool over.
19. Place the guide arm (30) and pedestal assembly (29) over the swivel assembly and spool (5).

NOTE: For the hose reel to operate correctly, the alignment of the swivel to the key hole in the pedestal must be correct. See FIG. 23 (a) for the proper alignment needed.

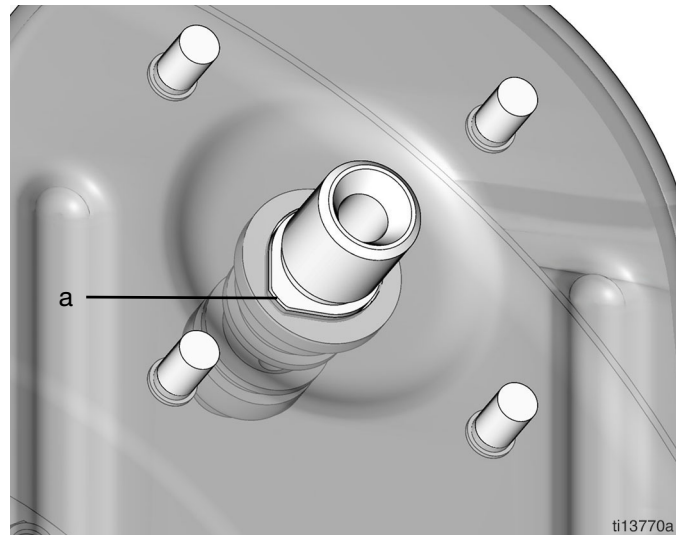

FIG. 23

ti13770a

20. Install large nut (11) and tighten (torque 85 - 105 ft-lb/115.2 - 142.4 N•m) (FIG. 22).
21. Tighten the bolt (18) (torque 25 - 35 ft-lb (33.9 - 47.5 N•m)).
22. Align the guide arm (29) and guide arm (30), then install screws (27) and tighten torque 20 - 30 ft-lb (27.1 - 40.7 N•m).
23. Align the pedestal assembly (26) to the base (24). Install two screws (27) and tighten (torque 20 - 30 ft-lb (27.1 - 40.7 N•m)).
24. Re-install the reel to the ceiling or wall.
25. Install the hose onto the spool following the **Hose Installation** instructions, page 18.
26. Flush the hose following **Flush the Equipment**, page 9.
27. Set the spring tension following **Adjust Spring Tension**, page 20.

Replace the Hose



1. Follow the **Pressure Relief Procedure**, page 9.
2. Fully extend the hose (B) and latch the reel (FIG. 24).
3. Attach a C-clamp (A) to the reel flange to prevent the reel from unintentionally becoming unlatched and spinning freely (FIG. 24).



SPRING TENSION HAZARD

The hose reel spring is always under great tension, which if released in an uncontrolled manner could cause serious injury.

- Never allow the reel to spin freely. Uncontrolled spinning could cause serious injury if hit by the hose.
- Securely fasten the reel in place while making adjustments.
- The hose reel spring is not a serviceable part. Do not attempt to replace or service the hose reel spring.
- Always wear heavy gloves while adjusting the spring tension to protect your hands from being cut on the hose reel.

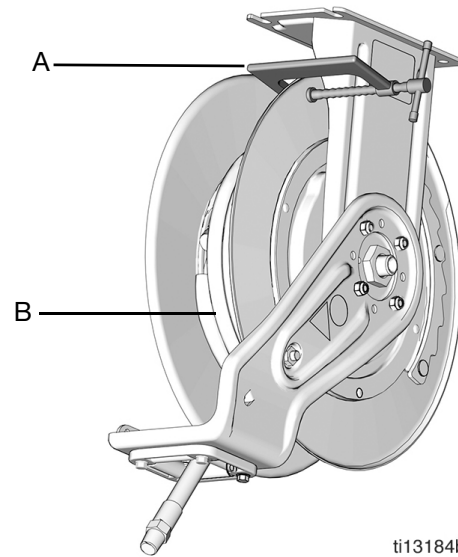

ti13184b

FIG. 24

4. Remove the hose stop from the hose end and put all of the parts in a secure place for re-installation on the new hose (FIG. 25).
 - a. Loosen and remove screws and nuts (FIG. 25).
 - b. Separate the two hose stop components to remove from the end of the hose (FIG. 25).

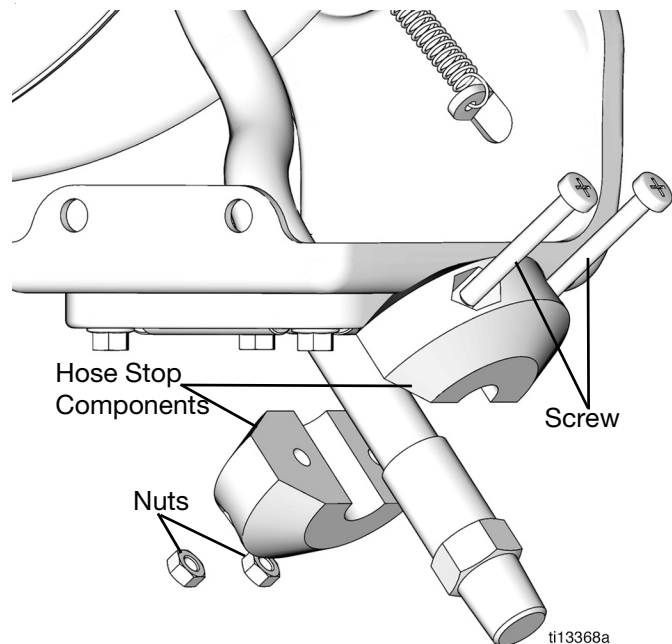

ti13368a

FIG. 25

5. Disconnect the hose (B) from the swivel (C) (FIG. 26).

6. Install the hose stop (D) to the end of the replacement hose. If the hose has a warning tag (F), the hose stop (D) should be installed on the same end as the warning tag (F) (FIG. 26).

NOTE: If the hose is equipped with a spring guard, this end must be on the same end as the hose stop.

7. Insert screws through the hose stop and hand tighten the nuts to hold the hose stop in place (FIG. 25).
8. Run the end of the hose (B) through the hose guide (G), and then through the hole (E) in the reel (FIG. 26).
9. Attach the hose end (B) to the hose reel swivel (C). Then carefully remove the C-clamp (D) (FIG. 24, page 26),

10. Pull the hose (B) hard enough to release the latch and slowly allow the hose to retract.
11. If used, re-assemble the hose reel enclosure.
12. Flush the hose following the **Flush the Equipment** instructions, page 9.

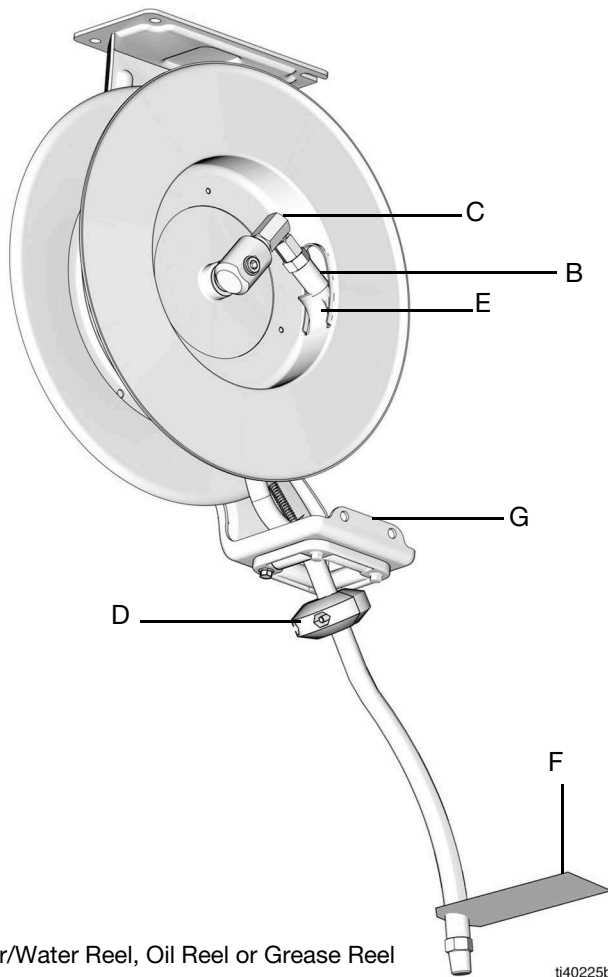
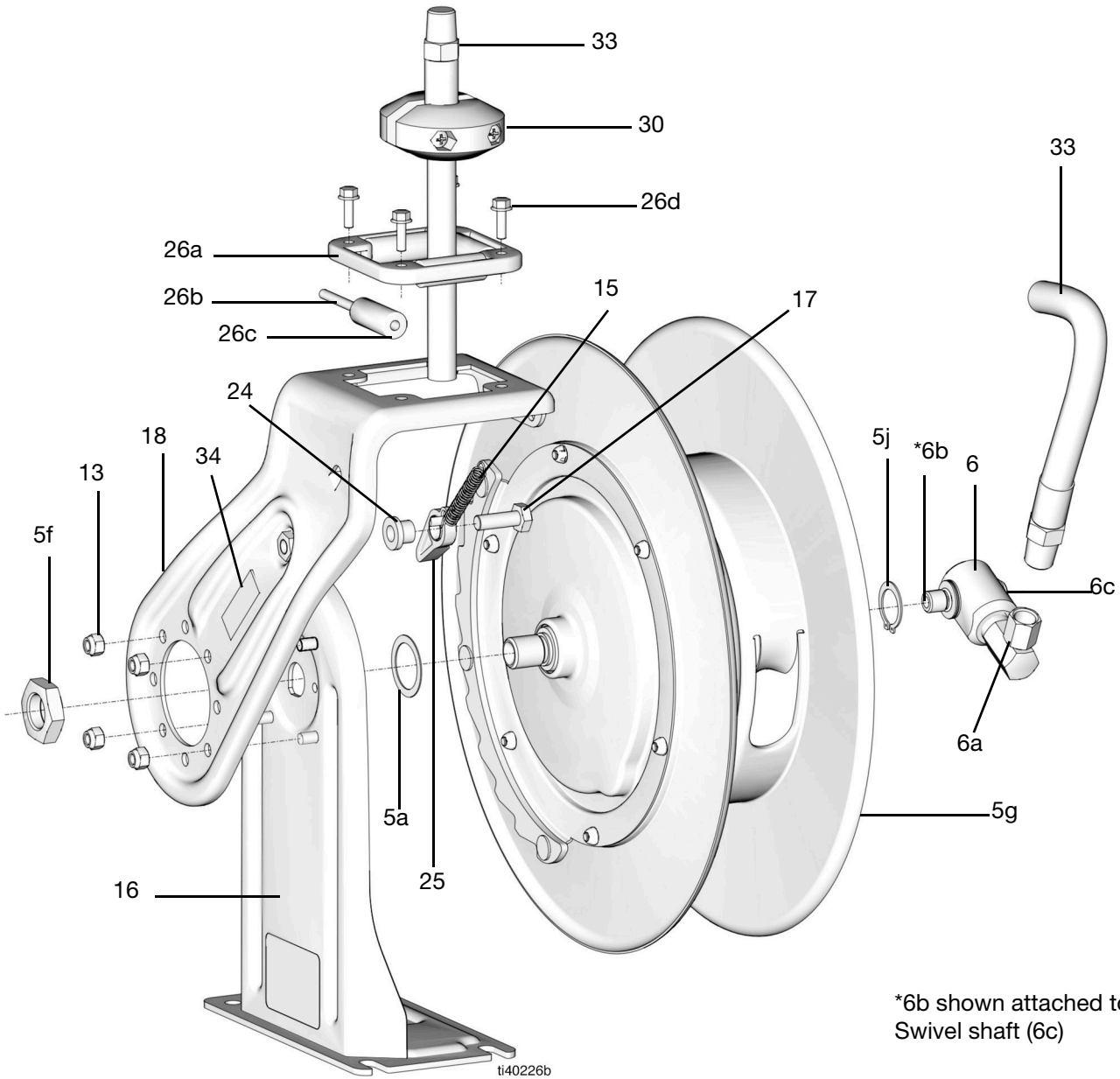

FIG. 26

Parts

SDX Models



Parts SDX Series

Ref	Part No.	Description	Qty
5		KIT, spool (includes 5a-5j) (see page 32)	1
5a‡		WASHER, thrust (all SDL and SDM models)	1
5a‡		WASHER, thrust (all SDH models)	1
5f‡	186579	NUT, hex, 3/8 in. x 18 NPSM (SDH Models)	1
5f‡	186580	NUT, hex, 12 in. - 14 npsm (SDL and SDM Models)	1
5g‡		SPOOL	1
5j‡		RING, snap	1
6	133502	KIT, swivel, SDX A/W 3/8, Models SDL23#, SDL25#, SDL56#	1
	133503	KIT, swivel, SDX A/W 1/2, Models SDL33#, SDL65# SDL6D#	1
	133504	KIT, swivel, SDX oil 1/2, Models SDM33#, SDM65#, SDM6D#, SDM6H#	1
	133505	KIT, swivel, SDX grease 3/8, Models SDH55#, SDH5D#	1
*6a	155470	FITTING, swivel, 90 degree, NPSM (Models SDL6D, SDL33, SDL65, SDM6D, SDM33, SDM65)	1
*6a	161037	FITTING, swivel, 90 degree, NPSM (Models SDL23, SDL25, SDL56)	1
*6a	15Y397	FITTING, swivel, 90 degree, NPSM (SDH Models)	2
*6b		O-RING	1
*6c		SHAFT, swivel	1
13	104541	NUT, lock, M8 x 1.25	4
15		SPRING, ratchet, pawl	1
16		BASE	1
17		BOLT, M10 x 1.50 x 25	1
18	15V139	ARM, guide (Metallic Blue) (Models SDL23, SDL25, SDL33, SDM33)	
	15V142	ARM, guide (Red) (Models SDL23, SDL25, SDL33, SDM33)	
	15V144	ARM, guide (Black) (Models SDL23, SDL25, SDL33, SDM33)	
	15V157	ARM, guide (Metallic Blue) (Models SDL56, SDL65, SDM65, SDM6D, SDH55, SDH5D)	
	15V159	ARM, guide (Yellow) (Models SDL56, SDL65, SDM65, SDM6D, SDH55, SDH5D)	

Ref	Part No.	Description	Qty
	15V160	ARM, guide (Red) (Models SDL56, SDL65, SDM65, SDM6D, SDH55, SDH5D)	
	15V161	ARM, guide (White) (Models SDL56, SDL65, SDM65, SDM6D, SDH55, SDH5D)	
	15V162	ARM, guide (Black) (Models SDL56, SDL65, SDM65, SDM6D, SDH55, SDH5D)	
24		BUSHING, pawl	1
25		PAWL, ratchet	1
26	218591	KIT, roller (includes 25a-25d) (see page 35)	1
26a		BRACKET, roller	1
26b		PIN, roller	4
26c		ROLLER, hose	4
26d		SCREW, M6 x 1.0 x 20	4
30		KIT, stop, hose (see page 35)	1
33	124461	HOSE, 50 ft, NPT (Models SDH55A, SDH55B, SDH55C, SDH55D, SDH55E, SDHE5F)	1
	25U035	HOSE, 35 ft, NPT (Models SDL23B, SDL23C, SDL23D, SDL23E)	1
	25U036	HOSE, 50 ft, NPT (Models SDL25B, SDL25C, SDL25D, SDL25E)	1
	25U037	HOSE, 65 ft, NPT (Models SDL56A, SDL56B, SDL56C, SDL56D, SDL56E, SDL56F)	1
	25U038	HOSE, 35 ft, NPT (Models SDL33B, SDL33C, SDL33D, SDL33E)	1
	25U039	HOSE, 50 ft, NPT (Models SDL65A, SDL65B, SDL65C, SDL65D, SDL65E, SDL65F)	1
	26C121	HOSE, 35 ft, NPT (Models SDM33B, SDM33C, SDM33D, SDM33E)	1
	26C122	HOSE, 50 ft, NPT (Models SDM65A, SDM65B, SDM65C, SDM65D, SDM65E, SDM65F)	1
34▲	15W036	LABEL, warning	1

*Included in Swivel Kit, page 32

‡Included in Spool Kit, page 32.

▲Replacement safety labels, tags, and cards are available at no cost.

A complete list of all available kits begins on page 32.

XDX Models

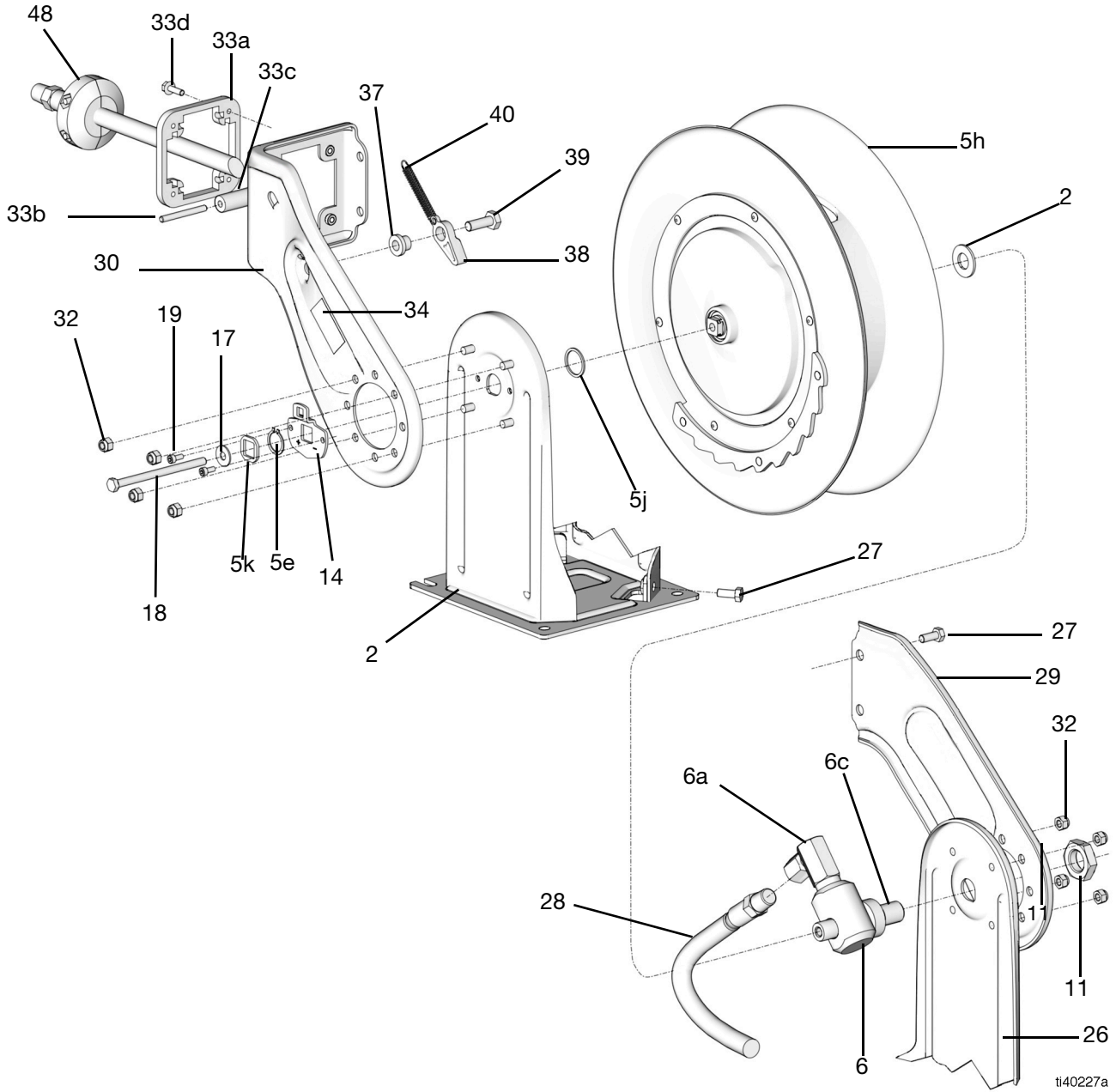

Water Reel, Oil Reel or Grease Reel

Parts XDX Series

Ref	Part No.	Description	Qty
2		WASHER, flat	1
5		KIT, spool (see page 32) (includes parts 5a-5k)	1
5e‡		RING, retaining	1
5h‡		SPOOL	1
5j‡		WASHER, 30 mm	1
5k‡		WASHER, square center	1
6	133506	KIT, swivel, XDX grease 3/8	1
	133507	KIT, swivel, XDX oil 1/2	1
	133508	KIT, swivel, XDX A/W 1/2	1
	133509	KIT, swivel, XDX A/W 3/8	1
*6a	155470	FITTING, swivel, 90 degree NPSM (Models XDL65, XDL6D, XDM65, XDM6D)	1
*6a	15Y397	FITTING, swivel, 90degree NPSM (XDH Models)	1
*6a	161037	FITTING, swivel, 90 degree NPSM (Models XDL25, XDL2D, XDL56, XDL5D)	1
*6c		SHAFT, swivel	1
11	186579	NUT, hex 3/8 in. - 18 NPSM (Models XDH55, XDH55B)	1
11	186580	NUT, hex 1/2 in. - 14 NPSM (Models XDL56, XDL65)	1
14		ADJUSTER, power spring	1
17	100023	WASHER, 8 mm	1
18		SCREW, M8 x 1.25 x 120	1
19		SCREW, M5 x .80 x 20	2
24		BASE, dual	1
26		PEDESTAL	1
27		SCREW, M8 x 1.25 x 20	4
28	124461	HOSE, 50 ft, NPT (Models XDH55A, XDH55B, XDH55F)	1
	25U037	HOSE, 65 ft, NPT (Models XDL56A, XDL55B, XDL55F)	1
	25U039	HOSE, 50 ft, NPT (Models XDL65A, XDL65B)	1
	26C122	HOSE, 50 ft, NPT (Models XDM65A, XDM65B, XDM65F)	1
29	15V163	ARM, guide, dual (Metallic Blue) (Models XDL56, XDL65, XDM65, XDH55, XDH5D, XDM6D)	

Ref	Part No.	Description	Qty
	15V164	ARM, guide, dual (White) (Models XDL56, XDL65, XDM65, XDH55, XDH5D, XDM6D)	
	15X942	ARM, guide, dual (Yellow) (Models XDL56, XDL65, XDM65, XDH55, XDH5D, XDM6D)	
	18F249	ARM, guide, dual (Black) (Models XDL56, XDL65, XDM65, XDH55, XDH5D, XDM6D)	
30	15V161	ARM, guide (White) (Models XDL56, XDL65, XDM65, XDH55, XDH5D, XDM6D)	
	15V157	ARM, guide (Metallic Blue) (Models XDL56, XDL65, XDM65, XDH55, XDH5D, XDM6D)	
	15V159	ARM, guide (Yellow) (Models XDL56, XDL65, XDM65, XDH55, XDH5D, XDM6D)	
	15V162	ARM, guide (Black) (Models XDL56, XDL65, XDM65, XDH55, XDH5D, XDM6D)	
32	104541	NUT, lock, M8 x 1.25	8
33	218591	KIT, roller (includes 33a-33d) (page 35)	
33a		BRACKET, roller	1
33b		PIN, roller	4
33c		ROLLER, hose	4
33d		SCREW, M6 x 1.0 x 20	4
34▲	15W036	LABEL, warning	1
37		BUSHING, pawl	1
38		PAWL, ratchet	1
39		BOLT, M10 x 1.5 x 25 lg	1
40		SPRING, ratchet pawl	1
48		KIT, stop, hose (page 35)	1

*Included in Swivel Kit, page 32

‡Included in Spool Kit, page 32.



▲Replacement safety labels, tags, and cards are available at no cost.

A complete list of all available kits begins on page 32.

Kits

Reel P/N	Frame Size	Fluid	Hose Size (in./mm)	Hose Length (ft/mm)	Spool Kit	Swivel Kit
SDL6D#	SDX20	Air/Water	1/2	50	18F132	133503
SDL23#	SDX10	Air/Water	3/8	35	18F133	133502
SDL25#	SDX10	Air/Water	3/8	50	18F131	133502
SDL56#	SDX20	Air/Water	3/8	65	18F134	133502
SDL33#	SDX10	Air/Water	1/2	35	18F133	133503
SDL65#	SDX20	Air/Water	1/2	50	18F132	133503
SDM6D#	SDX20	Oil	1/2	50	18F141	133504
SDM33#	SDX10	Oil	1/2	35	18F135	133504
SDM65#	SDX20	Oil	1/2	50	18F141	133504
SDM6H#	SDX Truck 20	Oil	1/2	50	18F141	133504
SDH5D#	SDX20	Grease	3/8	50	18F139	133505
SDH55#	SDX20	Grease	3/8	50	18F139	133505
XDL6D#	XDX20	Air/Water	1/2	50	15Y497	133508
XDL56#	XDX20	Air/Water	3/8	65	15Y498	133509
XDL65#	XDX20	Air/Water	1/2	50	15Y497	133508
XDM6D#	XDX20	Oil	1/2	50	15Y502	133507
XDM65#	XDX20	Oil	1/2	50	15Y502	133507
XDH5D#	SDX20	Grease	3/8	50	15Y502	133506
XDH55#	SDX20	Grease	3/8	50	15Y502	133506

Hose Reel Label

MODEL	1 st	2 nd	3 rd	6 th
SERIES				7 th
SERIAL				
BARE REEL MAX WPR				
	PSI (bar)	(MPa)
REEL W/HOSE MAX WPR				
	PSI (bar)	(MPa)
	GRACO INC. P.O. Box 1441 Minneapolis, MN U.S.A. 55440-1441			Designed and assembled in the U.S.A. with global components
				Art No. 29A379 rev. B

ti40460a

FIG. 27

NOTE:

The 1ST AND 2nd character in the model number determines the reel type category (FIG. 27).

- SD= SDX Series
- XD = XDX Series

The 3rd character in the model number determines the reel pressure category (FIG. 27).

- L = Low Pressure
- M = Medium Pressure
- H= High Pressure

The 6th character in the model number determines the color.

- A = White
- B = Blue
- C = Red (SDX Models only)
- D = Black
- F = Yellow

The 7th (last) character in the hose reel series is the Series Letter.

Label, Fluid Identification: 24A223

ANTI-FREEZE	HYDRAULIC
SAE 10W-40	ATF
SAE 10W-30	DEXRON
SAE 5W-40	SYNTHETIC
SAE 10W	SAE 5W-30
SAE 20W	SAE 5W-40
SAE 30W	AIR

FIG. 28

Latch Kit: 15Y503

(Instruction Manual: 406801)

Description	Qty
SCREW, M8 x 1.25 X 20	2
PAWL, ratchet	1
SPRING, ratchet, pawl	1
SCREW, M10 x 1.50 x 25	1
BUSHING	1
NUT, M8 x 1.25	4
SCREW, M8 x 1.50 x 40	1
NUT, M10 x 1.50	1

Enclosure Retrofit Kit: 24C100

(Instruction Manual: 313902)

For mounting an SDX 10 Series hose reel into a Graco 250 Series hose reel enclosure.

Description	Qty
ARM, hose guide	1
BASE, reel, enclosed	1
NUT, lock	4
SCREW	4
WASHER, flat	3
BOLT, M10 x 40 lg	1
NUT, hex	1
WASHER, lock, spring	1
NUT, lock	4
SCREW	4
NUT, hex	5
WASHER, lock	1
SCREW, shoulder, #10	1

Hose Inlet Kit

(Instruction Manual 406741)

Description	Qty
1/4 NPT Inlet: 224417	
HOSE, coupled, 24 in.	1
FITTING, UNION, ADAPTER, 90°	1
3/8 Inlet: 218550	
HOSE, coupled, 24 in.	1
FITTING, union, adapter, 90°	1
1/2 NPT Inlet: 218549	
HOSE, coupled, 24 in.	1
FITTING, swivel, union, 90°	1

Mounting Adapter: 24A224

(page 11)

Description	Qty
BASE, adapter	1
SCREWS, 3/8 in. - 16 x 3/4 in.	4

Hose Guide Kits

Roller Bracket Repair: 218591

(Instruction Manual: 406743)

Description	Qty
BRACKET, hose guide	1
PIN, roller	4
ROLLER, hose	4
NUT, lock, #10 - 32	4
SCREW, #10 - 32 x 3/4 in.	4
SCREW, M6 x 1.0 x 20	4

Cabinet Mounting Kit: 15Y478

Description	Qty
BRACKET, hose guide	1
PIN, roller	4
ROLLER, hose	4
PLATE, mounting	1
NUT, lock, #10 - 32	4
SCREW, #10 - 32 x 3/4 in.	4

Hose Reel Stop Kit

(Instruction Manual: 406742)

1/4 in. and 3/8 in. ID Hoses: 218340

Description	Qty
NUT, hex, jam	2
SCREW, machine, phillips	2
STOP, hose, 0.656 in. ID	2

3/8 in. and 1/2 in. ID Hoses: 218341

Description	Qty
NUT, hex, jam	2
SCREW, machine, phillips	2
STOP, hose, 0.782in. ID Kit	2

1/4 in. ID Hoses: 222225

Description	Qty
NUT, hex, jam	2
SCREW, machine, phillips	2
STOP, hose, 0.53 in. ID Kit	2

Dimensions SDX Models

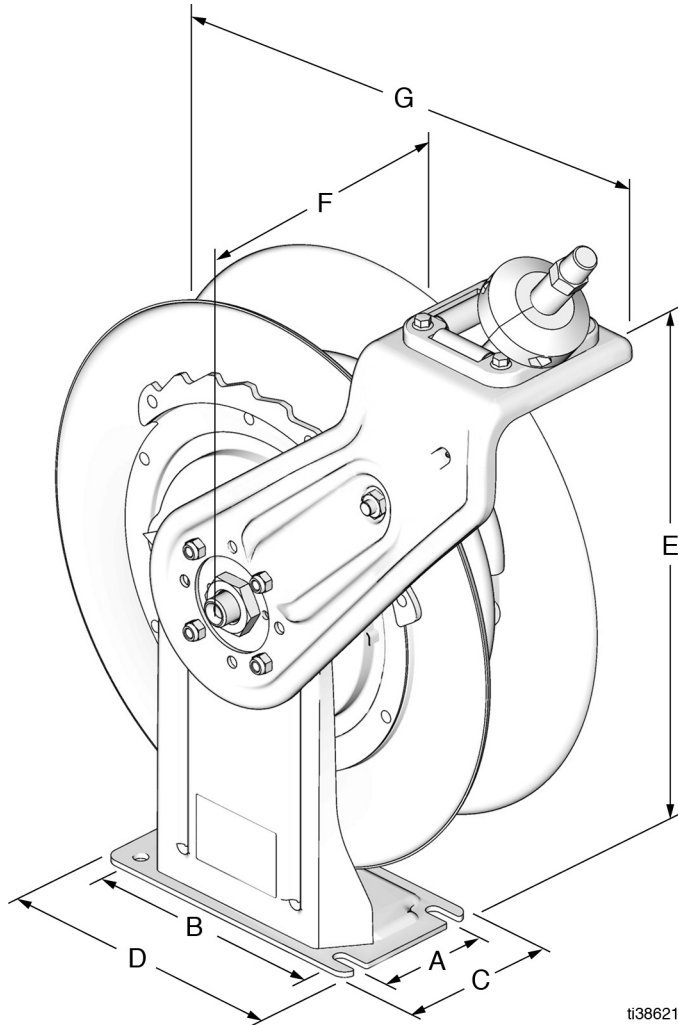

ti38621a

Pressure	Size	A	B*	C	D	E†	F	G◆
Low	10	3.5 in. (89 mm)	7.5 in. (191 mm)	4.7 in. (119 mm)	9.0 in. (229 mm)	19.5 in. (495 mm)	7.0 in. (178 mm)	17.1 in. (434 mm)
Medium	10							
High	10							
Low	20	3.5 in. (89 mm)	7.5 in. (191 mm)	4.7 in. (119 mm)	9.0 in. (229 mm)	21.8 in. (554 mm)	7.0 in. (178 mm)	19.2 in. (488 mm)
Medium	20							
High	20							

*Measurement taken from center to center of bolt slot/hole.

†Measurement taken from base to top of bolts.

◆Measurement taken from edge of pool to front of arm.

XDX Models

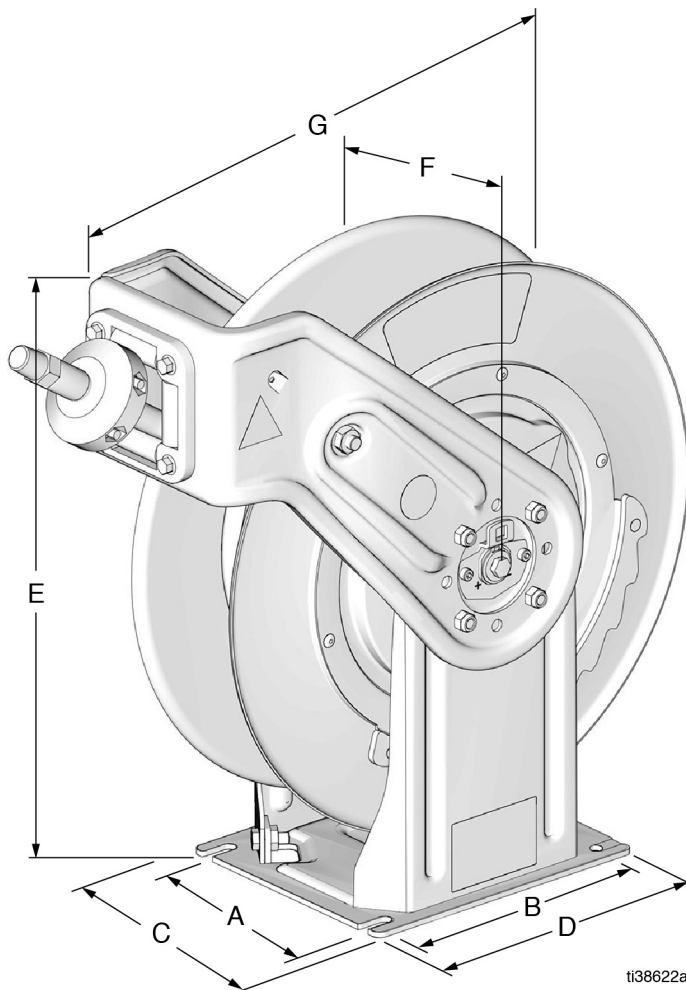

ti38622a

Pressure	Size	A	B*	C	D	E†	F	G◆
Low	10	6.5 in. (165 mm)	7.5 in. (191 mm)	7.7 in. (196 mm)	9.0 in. (229 mm)	18.5 in. (470 mm)	7.7 in. (196 mm)	18.0 in. (457 mm)
Medium	10							
High	10							
Low	20	6.5 in. (165 mm)	7.5 in. (191 mm)	7.7 in. (196 mm)	9.0 in. (229 mm)	21.0 in. (533 mm)	7.7 in. (196 mm)	20.0 in. (508 mm)
Medium	20							
High	20							

*Measurement taken from center to center of 11 mm bolt slot/hole.

†Measurement taken from base to top of bolts.

◆Measurement taken from edge of spool to front of arm.

Mounting Channel Dimensions

(Side dimension for all kits, page 43)

1 Reel Base - Included in Kits 24A934/203521 - SDX Models

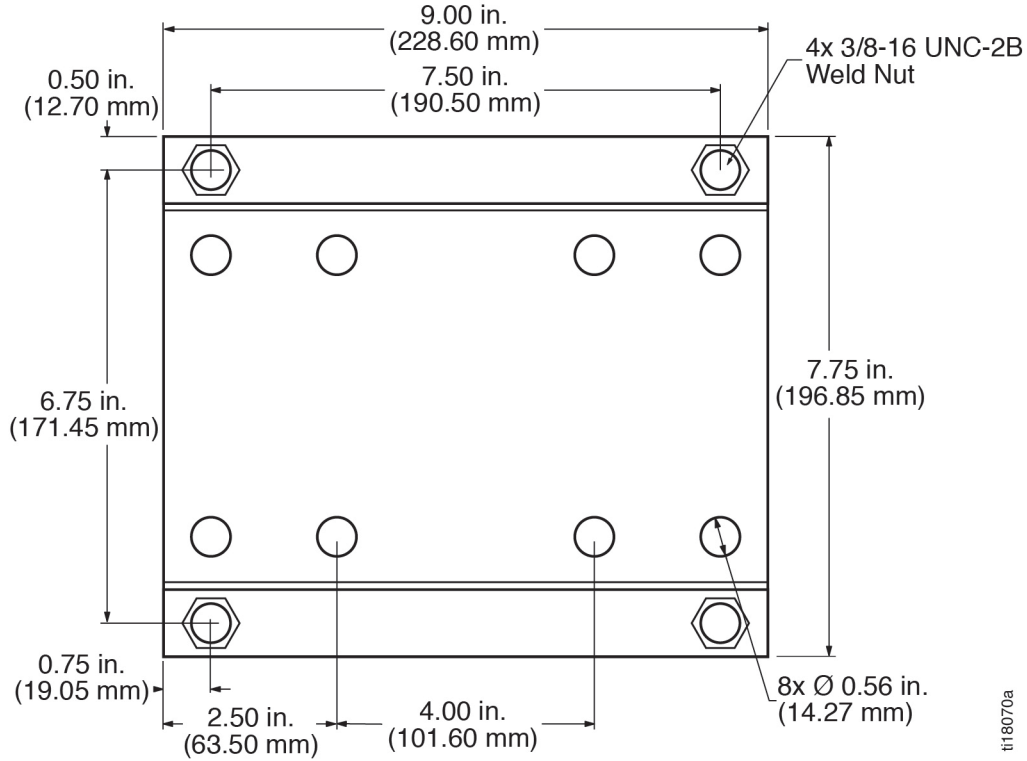

2 Reel Base - Included in Kits 24A935/203522 - SDX Models

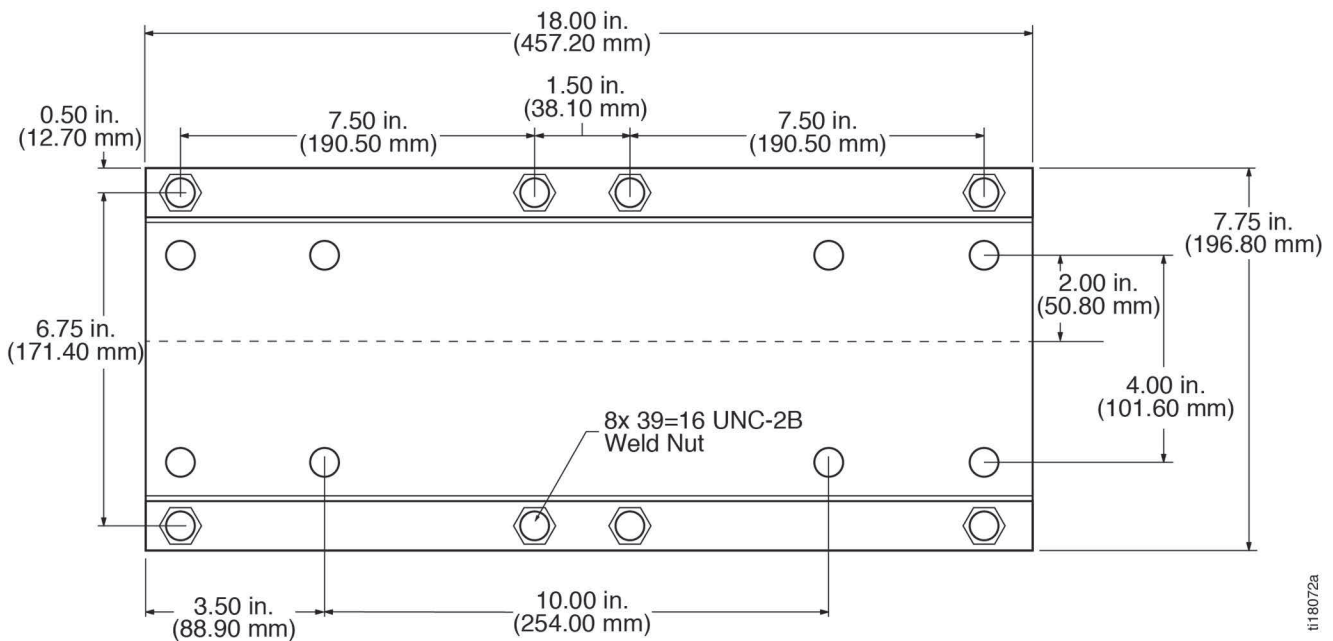

**3 Reel Base -
Included in Kits 24A936/203523 - SDX Models**

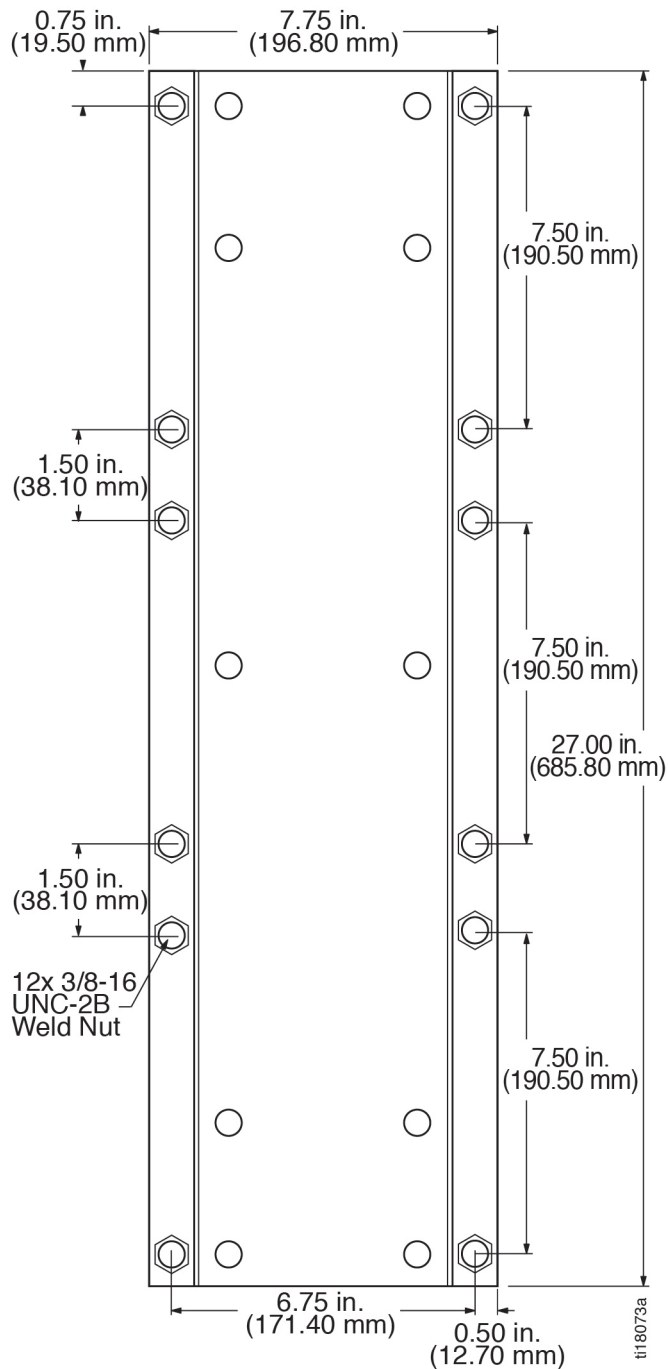

**4 Reel Base -
Included in Kits 24A937/203524 - SDX Models**

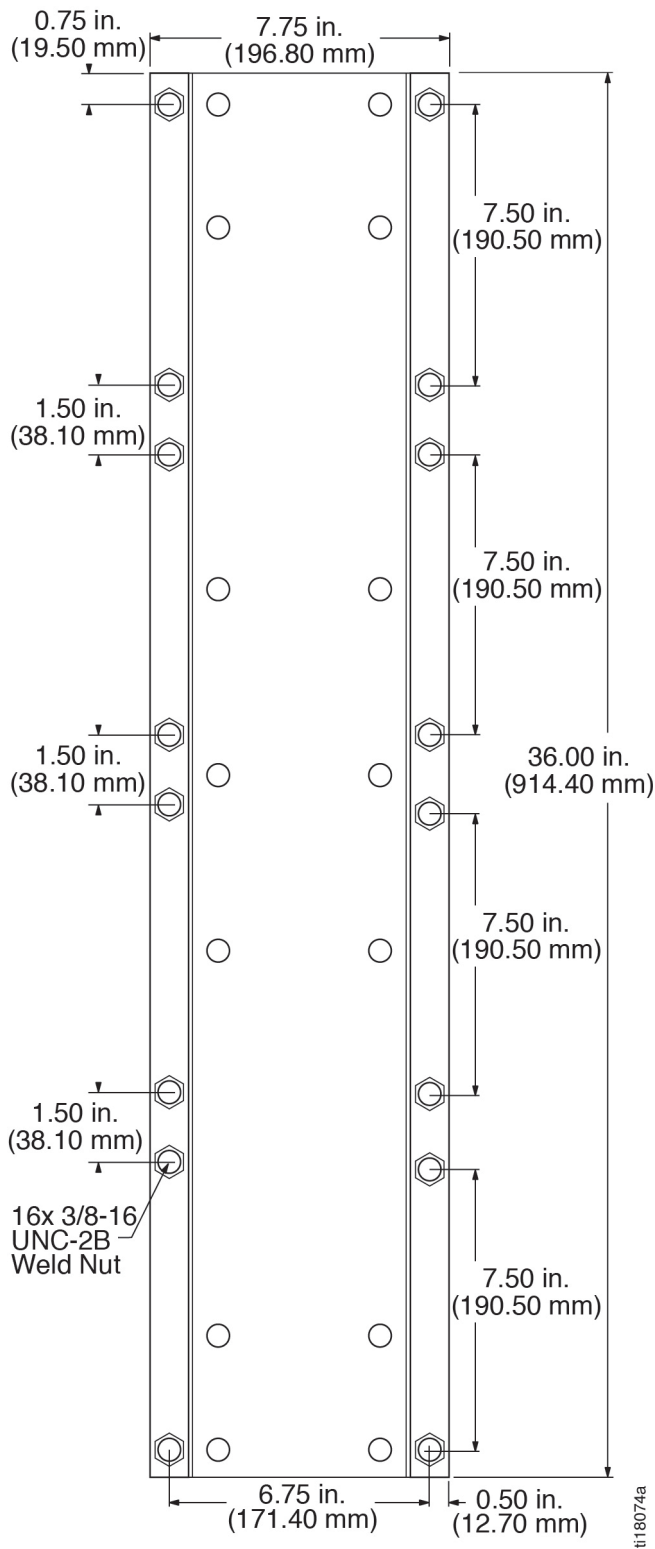

**5 Reel Base -
Included in Kits 24A938/203525 - SDX Models**

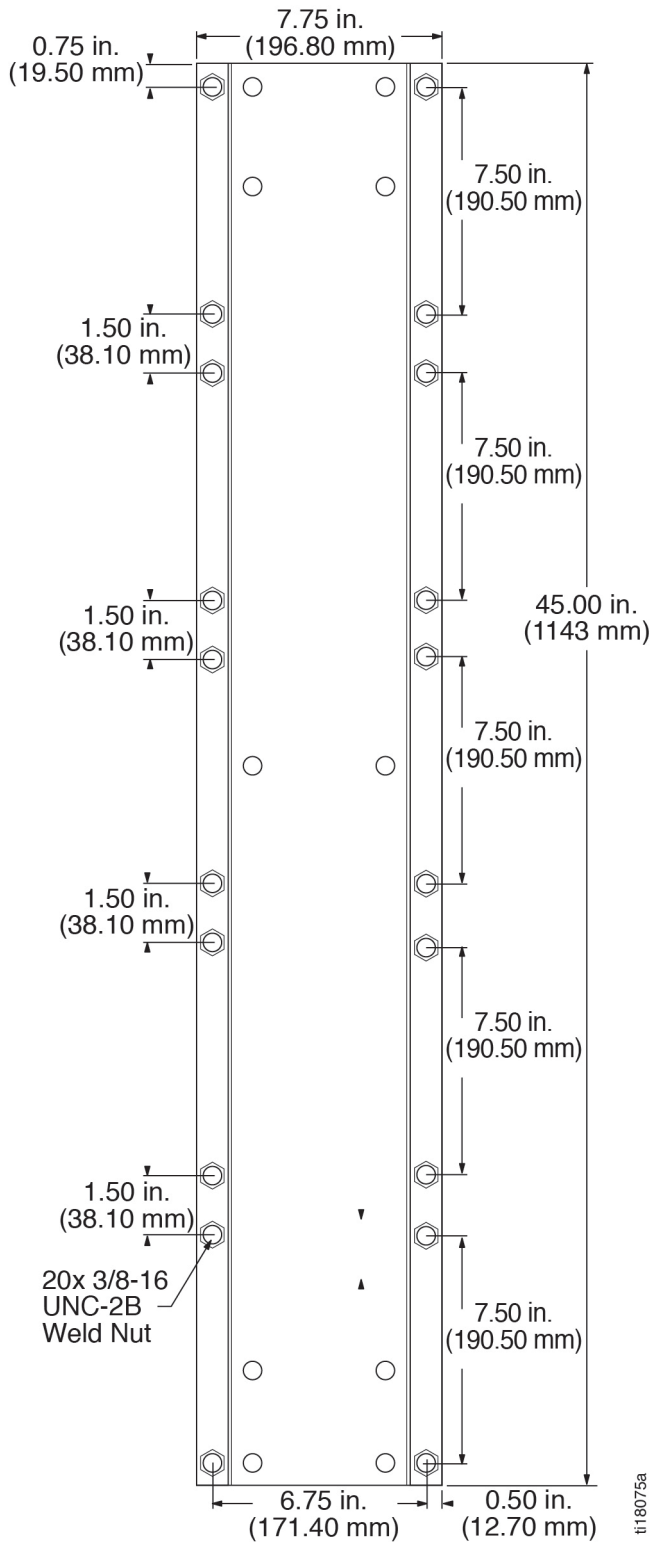

**6 Reel Base -
Included in Kits 24A939/203526 - SDX Models**

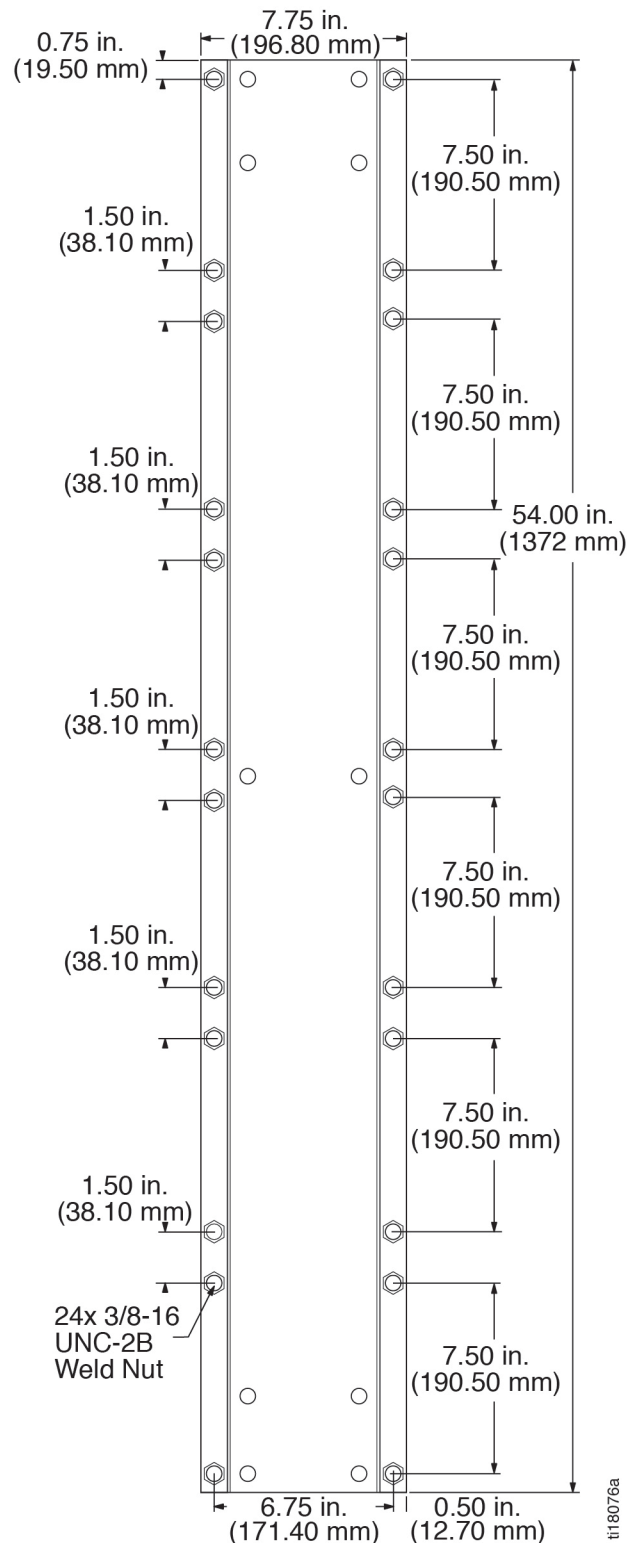

1 Reel Base - Included in Kits 24A219 - XDX Models

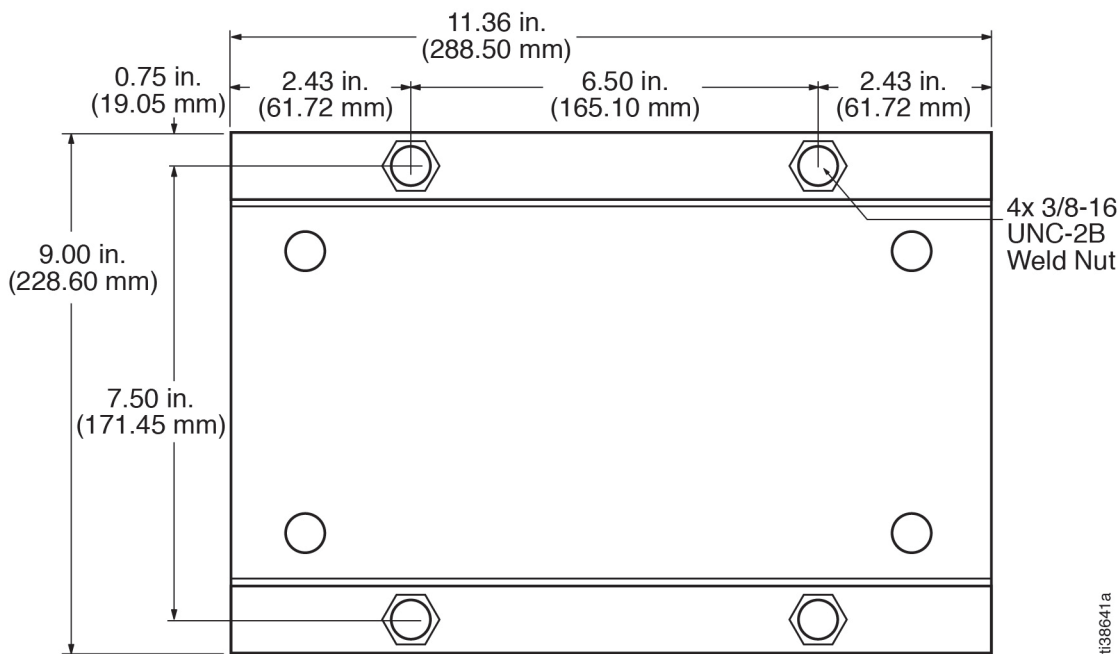

2 Reel Base - Included in Kit 24A220 - XDX Models

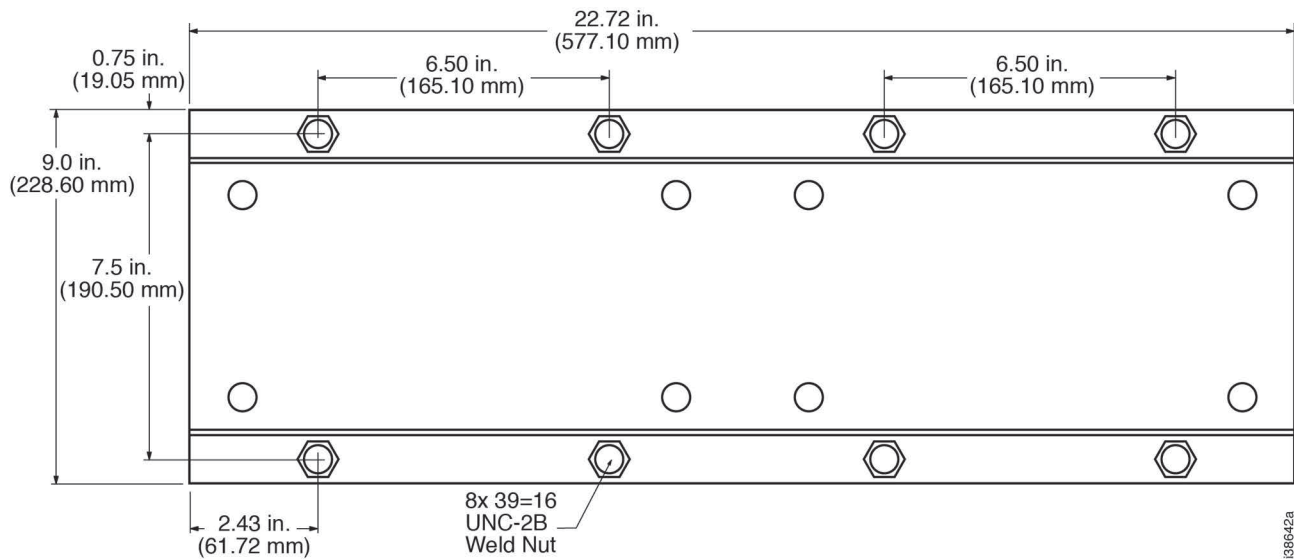

Dimensions

**3 Reel Base -
Included in Kits 24A221 - XDX Models**

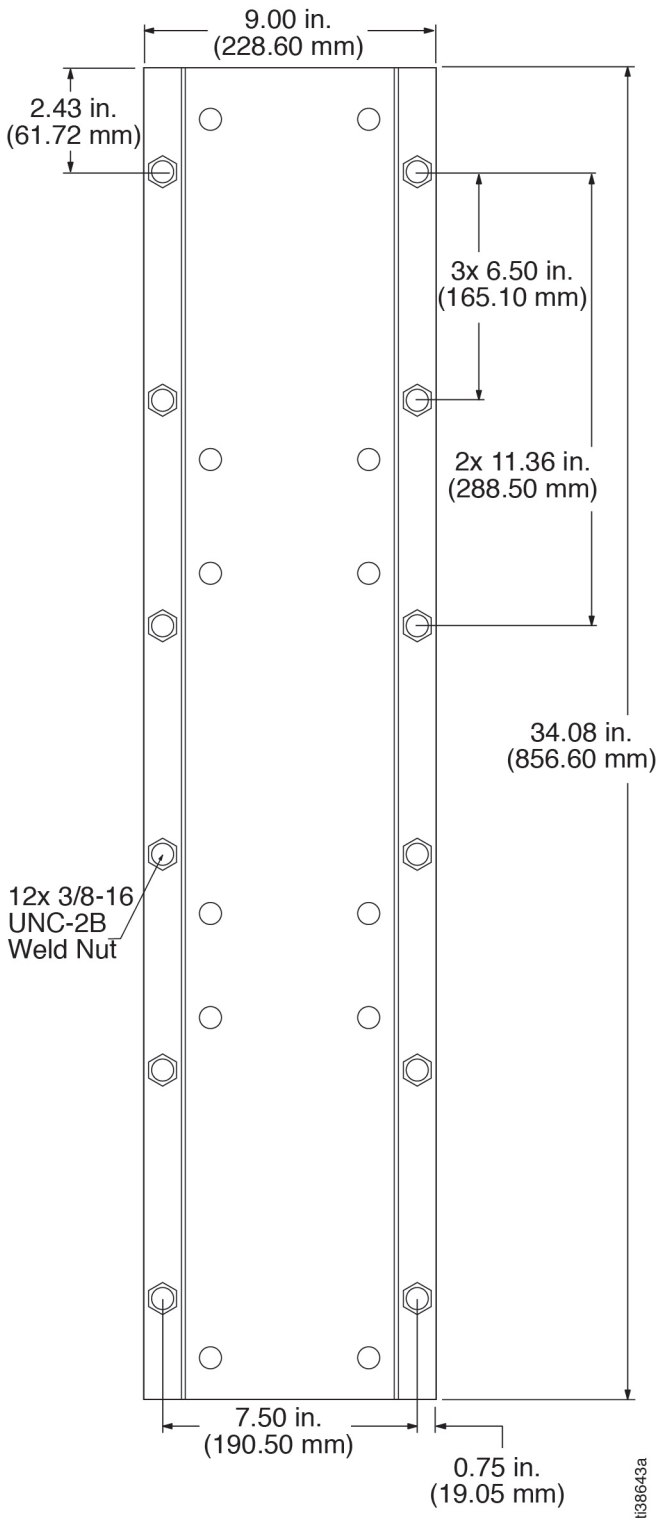

**6 Reel Base -
Included in Kits 24A222 - XDX Models**

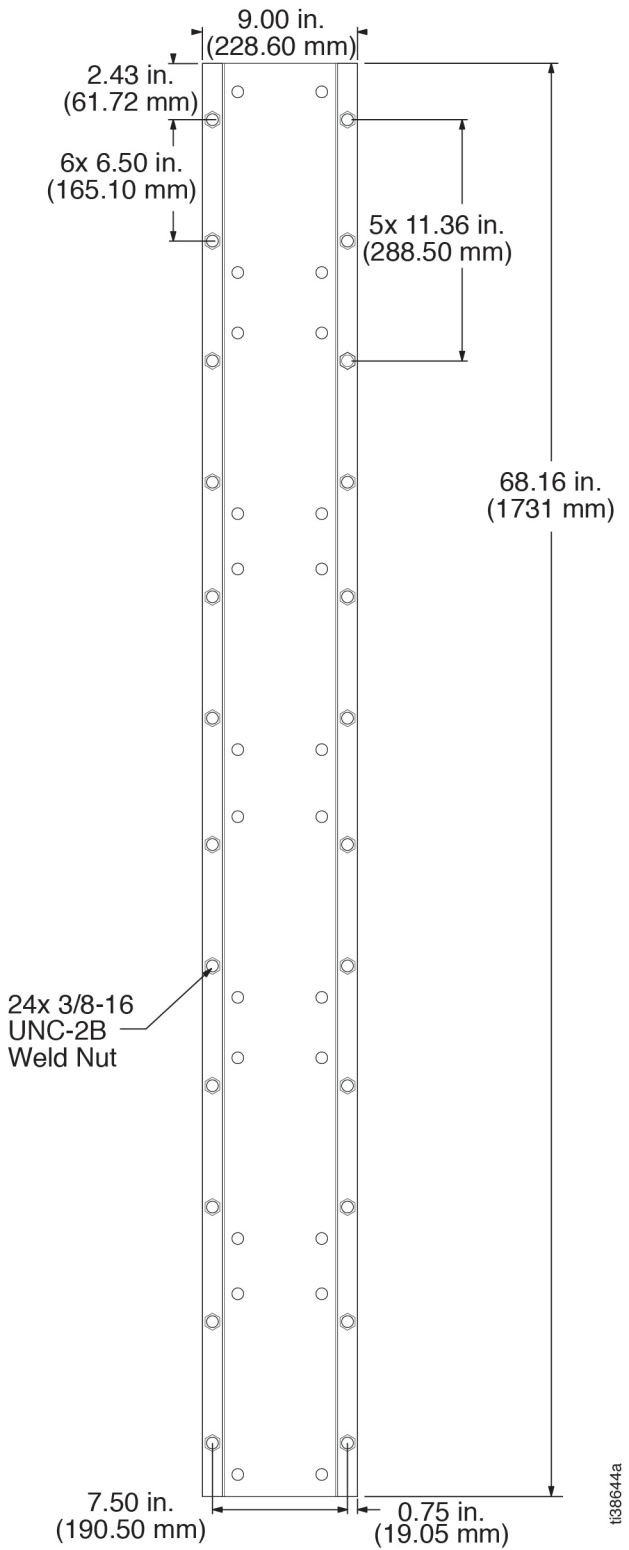

Side Dimension (All Models)



Technical Specifications

SDX, and XDX 10/20 Series Hose Reels		
	US	Metric
Low Pressure Hose Reels		
Maximum fluid working pressure (Air/Water, all hose diameters)	300 psi	2.1 MPa, 21 bar
Inlet size	1/2 npsm male	
Swivel outlet size	3/8 or 1/2 NPSM(f)	
Hose outlet size	3/8 or 1/2 NPT(m)	
Operating temperature range	-20° - 190°F	-29° - 88°C
Wetted parts - Bare Hose Reel only	Stainless steel, anodized aluminum, Nitrile rubber	
Medium Pressure Hose Reels		
Maximum fluid working pressure (Oil)	2000 psi	14 MPa, 138 bar
Inlet size	1/2 npsm male	
Swivel outlet size	1/2 NPSM(f)	
Hose outlet size	1/2 NPT male	
Operating temperature range	-20° - 190°F	-29° - 88°C
Wetted parts - Bare Hose Reel only	Zinc plated steel, anodized aluminum, Nitrile rubber	
High Pressure Hose Reels		
Maximum fluid working pressure (grease, all hose diameters)	5000 psi	35 MPa, 345 bar
Inlet size	3/8 NPSM male	
Swivel outlet size	3/8 NPSM (f)	
Hose outlet size	1/4 NPT male	
Operating temperature range	-40° - 200°F	-40° - 93°C
Wetted parts - Bare Hose Reel only	Zinc plated steel, Nitrile rubber, steel	
Dry Weight (Approximate)*		
SDX Models (for example SDH55B)		52 lbs (23.6 kg)
XDX Models (for example XDH55B)		59 lbs (26.7 kg)
Noise (dBa)		
Maximum sound pressure		
SDX Model		80 dB(A)
XDX Model		78 dB(A)
Maximum sound power		
SDX Model		87 dB(A)
XDX Model		88 dB(A)
<i>All readings taken at assumed retraction rate, from assumed operator position.</i>		
<i>Sound power measured per ISO-9614-2.</i>		
Notes		
* Weight will vary with each swivel base and hose selection.		
All trademarks or registered trademarks are the property of their respective owners.		

California Proposition 65

CALIFORNIA RESIDENTS

 **WARNING:** Cancer and reproductive harm – www.P65warnings.ca.gov.

Graco 7-Year Hose Reel Warranty

Graco warrants all equipment referenced in this document which is manufactured by Graco and bearing its name to be free from defects in material and workmanship on the date of sale to the original purchaser for use. With the exception of any special, extended, or limited warranty published by Graco, Graco will, for a period from the date of sale as defined in the table below, repair or replace equipment covered by this warranty and determined by Graco to be defective. This warranty applies only when the equipment is installed, operated and maintained in accordance with Graco's written recommendations.

Graco 7-Year Hose Reel Extended Warranty	
Component	Warranty Period
Structural Components	7 years
Power Spring	3 years
Wear Parts - including but not limited to hose, seals, swivel seats and roller guides	1 year
Bare reels - all components	1 year

This warranty does not cover, and Graco shall not be liable for general wear and tear, or any malfunction, damage or wear caused by faulty installation, misapplication, abrasion, corrosion, inadequate or improper maintenance, negligence, accident, tampering, or substitution of non-Graco component parts. Nor shall Graco be liable for malfunction, damage or wear caused by the incompatibility of Graco equipment with structures, accessories, equipment or materials not supplied by Graco, or the improper design, manufacture, installation, operation or maintenance of structures, accessories, equipment or materials not supplied by Graco.

This warranty is conditioned upon the prepaid return of the equipment claimed to be defective to an authorized Graco distributor for verification of the claimed defect. If the claimed defect is verified, Graco will repair or replace free of charge any defective parts. The equipment will be returned to the original purchaser transportation prepaid. If inspection of the equipment does not disclose any defect in material or workmanship, repairs will be made at a reasonable charge, which charges may include the costs of parts, labor, and transportation.

THIS WARRANTY IS EXCLUSIVE, AND IS IN LIEU OF ANY OTHER WARRANTIES, EXPRESS OR IMPLIED, INCLUDING BUT NOT LIMITED TO WARRANTY OF MERCHANTABILITY OR WARRANTY OF FITNESS FOR A PARTICULAR PURPOSE.

Graco's sole obligation and buyer's sole remedy for any breach of warranty shall be as set forth above. The buyer agrees that no other remedy (including, but not limited to, incidental or consequential damages for lost profits, lost sales, injury to person or property, or any other incidental or consequential loss) shall be available. Any action for breach of warranty must be brought within one (1) year past the warranty period or two (2) years for all other parts.

GRACO MAKES NO WARRANTY, AND DISCLAIMS ALL IMPLIED WARRANTIES OF MERCHANTABILITY AND FITNESS FOR A PARTICULAR PURPOSE, IN CONNECTION WITH ACCESSORIES, EQUIPMENT, MATERIALS OR COMPONENTS SOLD BUT NOT MANUFACTURED BY GRACO. These items sold, but not manufactured by Graco (such as electric motors, switches, hose, etc.), are subject to the warranty, if any, of their manufacturer. Graco will provide purchaser with reasonable assistance in making any claim for breach of these warranties.

In no event will Graco be liable for indirect, incidental, special or consequential damages resulting from Graco supplying equipment hereunder, or the furnishing, performance, or use of any products or other goods sold hereto, whether due to a breach of contract, breach of warranty, the negligence of Graco, or otherwise.

FOR GRACO CANADA CUSTOMERS

The Parties acknowledge that they have required that the present document, as well as all documents, notices and legal proceedings entered into, given or instituted pursuant hereto or relating directly or indirectly hereto, be drawn up in English. Les parties reconnaissent avoir convenu que la rédaction du présente document sera en Anglais, ainsi que tous documents, avis et procédures judiciaires exécutés, donnés ou intentés, à la suite de ou en rapport, directement ou indirectement, avec les procédures concernées.

Graco Information

For the latest information about Graco products, visit www.graco.com.

For patent information, see www.graco.com/patents.

TO PLACE AN ORDER, contact your Graco distributor or call to identify the nearest distributor.

Phone: 612-623-6928 or **Toll Free:** 1-800-533-9655, **Fax:** 612-378-3590

*All written and visual data contained in this document reflects the latest product information available at the time of publication.
Graco reserves the right to make changes at any time without notice.*

Original instructions. This manual contains English. MM 3A8626

Graco Headquarters: Minneapolis

International Offices: Belgium, China, Japan, Korea

GRACO INC. AND SUBSIDIARIES • P.O. BOX 1441 • MINNEAPOLIS MN 55440-1441 • USA
Copyright 2021, Graco Inc. All Graco manufacturing locations are registered to ISO 9001.

www.graco.com
Revision G, October 2024