

# EVR

3A8565E

Electric Variable Ratio Proportioner

EN

*For use with two-component sealant and adhesive materials. For professional use only.*

**Not approved for use in explosive atmospheres or hazardous (classified) locations.**

2000 psi (13.8 MPa, 138 bar) Maximum Fluid Inlet Pressure

3500 psi (24.1 MPa, 241 bar) Maximum Fluid Outlet Pressure



## Important Safety Instructions

Read all warnings and instructions in this manual and in related manuals before using the equipment. Save these instructions.

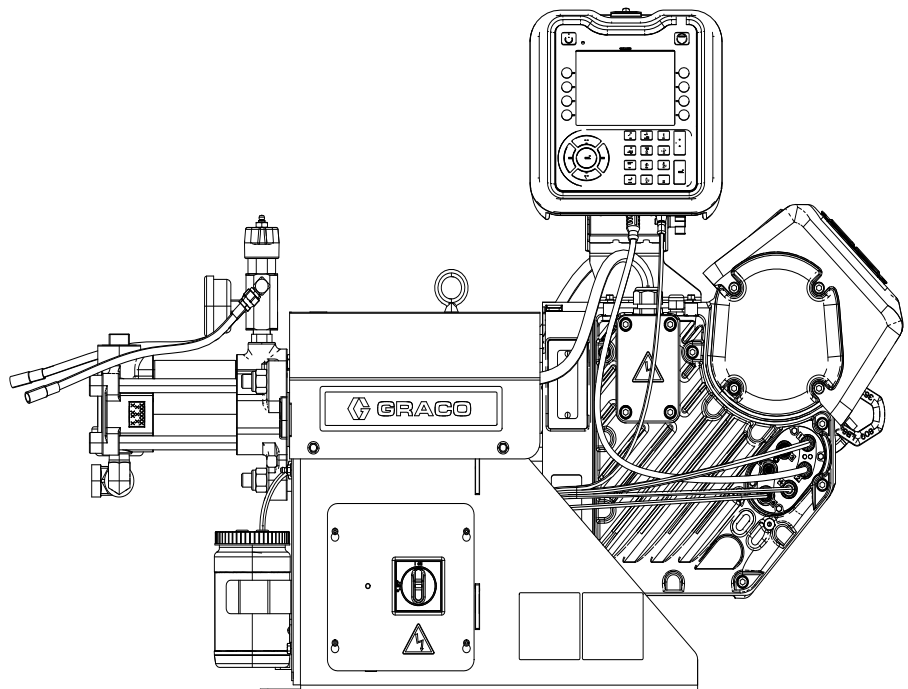

# Contents











<b>Related Manuals</b> .....	<b>3</b>	Maintenance Setup Screens .....	58
<b>Warnings</b> .....	<b>4</b>	Diagnostics Setup Screens .....	59
Keep Components A (Red) and B (Blue) Separate .....	6	Shot Log Setup Screens .....	61
Changing Materials .....	6	Errors Setup Screens .....	61
A (Red) and B (Blue) Components .....	6	Events Setup Screens .....	62
<b>Component Identification</b> .....	<b>7</b>	Integration Setup Screen .....	62
Interior Components .....	8	Fieldbus Setup Screens .....	63
Advanced Display Module (ADM) .....	9	PLC Inputs Setup Screens .....	64
<b>Installation</b> .....	<b>11</b>	PLC Outputs Setup Screens .....	65
Grounding .....	11	USB Plug-In Screen .....	66
Power Requirements .....	11	<b>Software Update</b> .....	<b>67</b>
Connect Power .....	11	19C237 Software Update Procedure .....	67
Install Vented Oil Cap Before Using Equipment .....	13	<b>I/O Integration</b> .....	<b>68</b>
<b>Setup</b> .....	<b>14</b>	<b>Communications Gateway Module (CGM)</b> .....	<b>69</b>
Flushing .....	15	Overview .....	69
<b>Operation</b> .....	<b>16</b>	Map Options .....	69
Startup .....	16	EVR and PLC Connection Setup .....	69
Shutdown .....	17	Available Internal Data .....	70
Pressure Relief Procedure .....	17	PLC Automation Inputs .....	70
Adjust Material Inlet Pressure .....	18	PLC Automation Outputs .....	81
<b>Maintenance</b> .....	<b>19</b>	Data Exchange .....	87
Preventative Maintenance Schedule .....	19	Heat Data Exchange .....	92
Check Oil Level .....	19	Time and Date .....	97
Change the Oil .....	20	Active Module Error Look-Up Table .....	98
Bearing Pre-Load .....	20	CGM General Timing Diagrams .....	100
Calibrate the Electric Driver .....	20	Connection Details .....	112
ADM - Battery Replacement and Screen Cleaning .....	21	<b>Appendix A - Obsolete EVR Maps</b> .....	<b>115</b>
Grease Cup Maintenance .....	22	PLC Inputs .....	115
<b>Troubleshooting</b> .....	<b>23</b>	PLC Outputs .....	118
EVR Error Codes .....	25	<b>Recycling and Disposal</b> .....	<b>120</b>
<b>Advanced Display Module (ADM) Operation</b> .....	<b>35</b>	End of Product Life .....	120
<b>ADM Screen Overview</b> .....	<b>36</b>	<b>Schematics</b> .....	<b>121</b>
Home Run Screen .....	36	<b>Dimensions</b> .....	<b>127</b>
Heat Run Screens .....	41	<b>Technical Specifications</b> .....	<b>129</b>
Vortex Dynamic Mix Valve Run Screen .....	42	<b>California Proposition 65</b> .....	<b>129</b>
Index Menu .....	44	<b>Graco Standard Warranty</b> .....	<b>130</b>
Recipe Definition Screens .....	44	<b>Graco Information</b> .....	<b>130</b>
System Setup Screens .....	45		
Heat Setup Screens .....	49		
Vortex Setup Screens .....	54		
Tank Stand Setup Screens .....	55		
Advanced Setup Screens .....	57		

## Related Manuals









Manual	Description
3A0019	Z-Series Chemical Pumps Instructions-Parts
3A6482	APD20 Advanced Precision Driver Instructions
312185	MD2 Valve Instructions-Parts
3A6338	Communications Gateway Module Installation Kit Instructions-Parts
3A6394	Z-Series Chemical Pumps High Wear Instructions-Parts
3A6321	ADM Token In-System Programming Instructions
3A0395	Stainless Steel Tank Stands Instructions-Parts

# Warnings

The following warnings are for the setup, use, grounding, maintenance, and repair of this equipment. The exclamation point symbol alerts you to a general warning and the hazard symbols refer to procedure-specific risks. When these symbols appear in the body of this manual or on warning labels, refer back to these Warnings. Product-specific hazard symbols and warnings not covered in this section may appear throughout the body of this manual where applicable.

 <h1 style="margin: 0;">WARNING</h1>	
    	<p><b>SKIN INJECTION HAZARD</b></p> <p>High-pressure fluid from dispensing device, hose leaks, or ruptured components will pierce skin. This may look like just a cut, but it is a serious injury that can result in amputation. <b>Get immediate surgical treatment.</b></p> <ul style="list-style-type: none"> <li>• Do not point dispensing device at anyone or at any part of the body.</li> <li>• Do not put your hand over the fluid outlet.</li> <li>• Do not stop or deflect leaks with your hand, body, glove, or rag.</li> <li>• Follow the <b>Pressure Relief Procedure</b> when you stop dispensing and before cleaning, checking, or servicing equipment.</li> <li>• Tighten all fluid connections before operating the equipment.</li> <li>• Check hoses and couplings daily. Replace worn or damaged parts immediately.</li> </ul>
   	<p><b>FIRE AND EXPLOSION HAZARD</b></p> <p>Flammable fumes, such as solvent and paint fumes, in <b>work area</b> can ignite or explode. Paint or solvent flowing through the equipment can cause static sparking. To help prevent fire and explosion:</p> <ul style="list-style-type: none"> <li>• Use equipment only in well-ventilated area.</li> <li>• Eliminate all ignition sources; such as pilot lights, cigarettes, portable electric lamps, and plastic drop cloths (potential static sparking).</li> <li>• Ground all equipment in the work area. See <b>Grounding</b> instructions.</li> <li>• Never spray or flush solvent at high pressure.</li> <li>• Keep work area free of debris, including solvent, rags and gasoline.</li> <li>• Do not plug or unplug power cords, or turn power or light switches on or off when flammable fumes are present.</li> <li>• Use only grounded hoses.</li> <li>• <b>Stop operation immediately</b> if static sparking occurs or you feel a shock. Do not use equipment until you identify and correct the problem.</li> <li>• Keep a working fire extinguisher in the work area.</li> </ul>

# ! WARNING

	<p><b>TOXIC FLUID OR FUMES HAZARD</b></p> <p>Toxic fluids or fumes can cause serious injury or death if splashed in the eyes or on skin, inhaled, or swallowed.</p> <ul style="list-style-type: none"> <li>• Read Safety Data Sheets (SDSs) to know the specific hazards of the fluids you are using.</li> <li>• Store hazardous fluid in approved containers, and dispose of it according to applicable guidelines.</li> </ul>
 	<p><b>MOVING PARTS HAZARD</b></p> <p>Moving parts can pinch, cut or amputate fingers and other body parts.</p> <ul style="list-style-type: none"> <li>• Keep clear of moving parts.</li> <li>• Do not operate equipment with protective guards or covers removed.</li> <li>• Equipment can start without warning. Before checking, moving, or servicing equipment, follow the <b>Pressure Relief Procedure</b> and disconnect all power sources.</li> </ul>
 	<p><b>ELECTRIC SHOCK HAZARD</b></p> <p>This equipment must be grounded. Improper grounding, setup, or usage of the system can cause electric shock.</p> <ul style="list-style-type: none"> <li>• Turn off and disconnect power at main switch before disconnecting any cables and before servicing or installing equipment.</li> <li>• Connect only to grounded power source.</li> <li>• All electrical wiring must be done by a qualified electrician and comply with all local codes and regulations.</li> </ul>
 	<p><b>EQUIPMENT MISUSE HAZARD</b></p> <p>Misuse can cause death or serious injury.</p> <ul style="list-style-type: none"> <li>• Do not operate the unit when fatigued or under the influence of drugs or alcohol.</li> <li>• Do not exceed the maximum working pressure or temperature rating of the lowest rated system component. See <b>Technical Specifications</b> in all equipment manuals.</li> <li>• Use fluids and solvents that are compatible with equipment wetted parts. See <b>Technical Specifications</b> in all equipment manuals. Read fluid and solvent manufacturer's warnings. For complete information about your material, request Safety Data Sheets (SDSs) from distributor or retailer.</li> <li>• Turn off all equipment and follow the <b>Pressure Relief Procedure</b> when equipment is not in use.</li> <li>• Check equipment daily. Repair or replace worn or damaged parts immediately with genuine manufacturer's replacement parts only.</li> <li>• Do not alter or modify equipment. Alterations or modifications may void agency approvals and create safety hazards.</li> <li>• Make sure all equipment is rated and approved for the environment in which you are using it.</li> <li>• Use equipment only for its intended purpose. Call your distributor for information.</li> <li>• Route hoses and cables away from traffic areas, sharp edges, moving parts, and hot surfaces.</li> <li>• Do not kink or over bend hoses or use hoses to pull equipment.</li> <li>• Keep children and animals away from work area.</li> <li>• Comply with all applicable safety regulations.</li> </ul>
	<p><b>PERSONAL PROTECTIVE EQUIPMENT</b></p> <p>Wear appropriate protective equipment when in the work area to help prevent serious injury, including eye injury, hearing loss, inhalation of toxic fumes, and burns. Protective equipment includes but is not limited to:</p> <ul style="list-style-type: none"> <li>• Protective eyewear, and hearing protection.</li> <li>• Respirators, protective clothing, and gloves as recommended by the fluid and solvent manufacturer.</li> </ul>

## Keep Components A (Red) and B (Blue) Separate



Cross-contamination can result in cured material in fluid lines which could cause serious injury or damage equipment. To prevent cross-contamination:

- Never interchange component A (red) and component B (Blue) wetted parts.
- Never use solvent on one side if it has been contaminated from the other side.

## A (Red) and B (Blue) Components

**NOTE:** Material suppliers can vary in how they refer to plural component materials.

For all machines:

- The A (Red) side is intended for hardeners and catalysts.
- The B (Blue) side is intended for polyols, resins, and bases. Regardless of the configuration of material used, the high volume material must be in the B (Blue) side.

## Changing Materials

### NOTICE

Changing the material types used in your equipment requires special attention to avoid equipment damage and downtime.

- When changing materials, flush the equipment multiple times to ensure it is thoroughly clean.
- Check with your material manufacturer for chemical compatibility.

# Component Identification

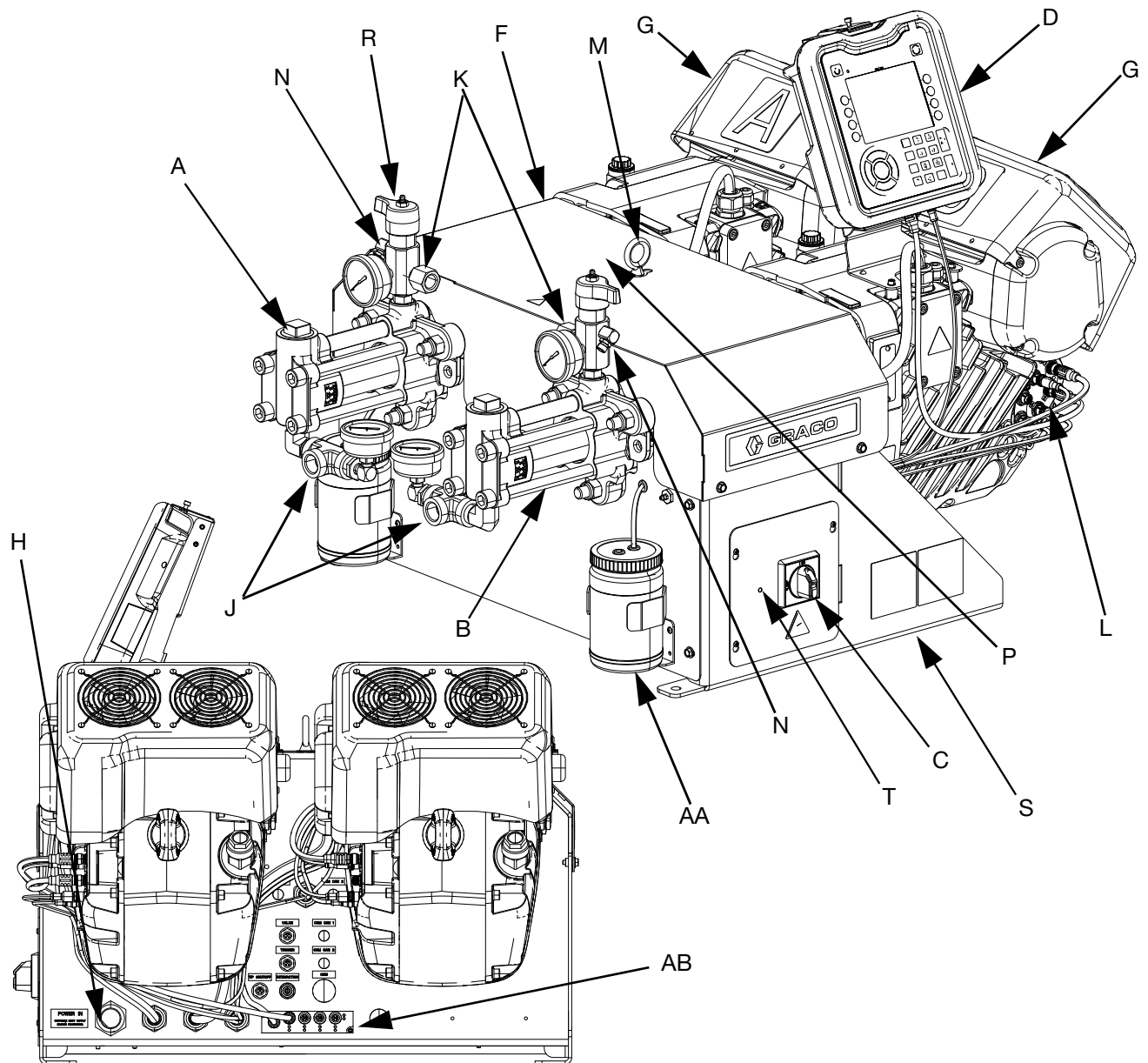

**FIG. 1: Component Identification**

**Key:**

- A A Pump
- B B Pump
- C Power Disconnect Switch
- D Advanced Display Module (ADM)
- F Pump Shroud
- G Electric Driver
- H Incoming Power Connection
- J Pump Inlets
- K Pump Outlets
- L Driver Communication and I/O Connectors
- M Lift Ring
- N Pressure Relief Drain Tubes
- P B-Side (Blue) Outlet Drain/Relief Valve\*

- R A-Side (Red) Outlet Drain/Relief Valve\*
- S EVR Frame
- T EVR Frame Cover
- AA Grease Receptacle
- AB CAN Distribution Block

\* Required components supplied with the system. EVR systems configured without pumps are provided with drain/relief valves, which must be installed after the pumps are assembled, but before placing the system into service.

## Interior Components

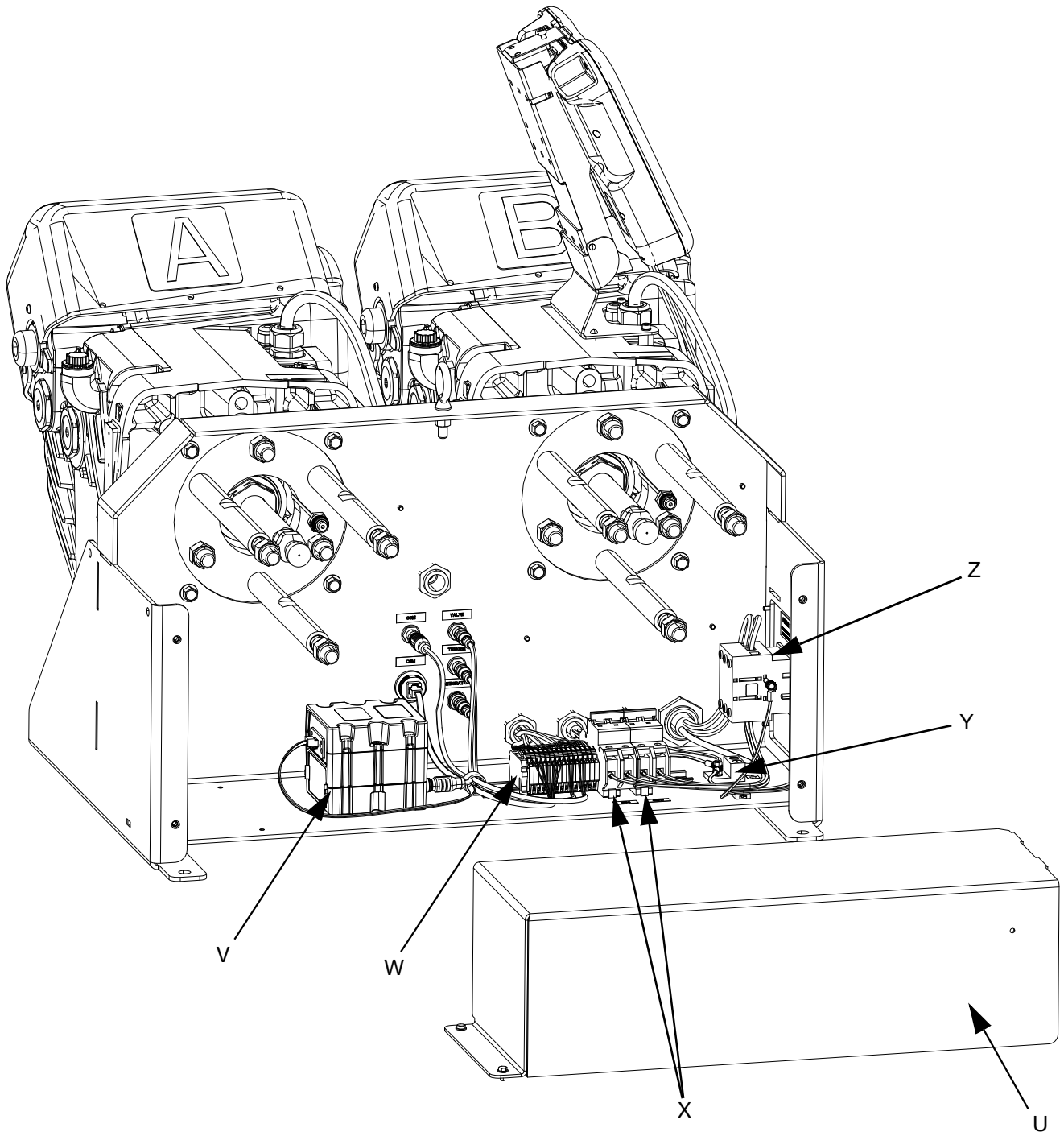

**FIG. 2: Interior Components**

**Key:**

- U Power Electronics Cover
- V Communications Gateway Module (CGM)
- W Terminal Block Connections
- X Circuit Breakers  
CB-1 (Unit B)  
CB-2 (Unit A)

- Y Ground Lug
- Z Disconnect Block



# Advanced Display Module (ADM)

## User Interface

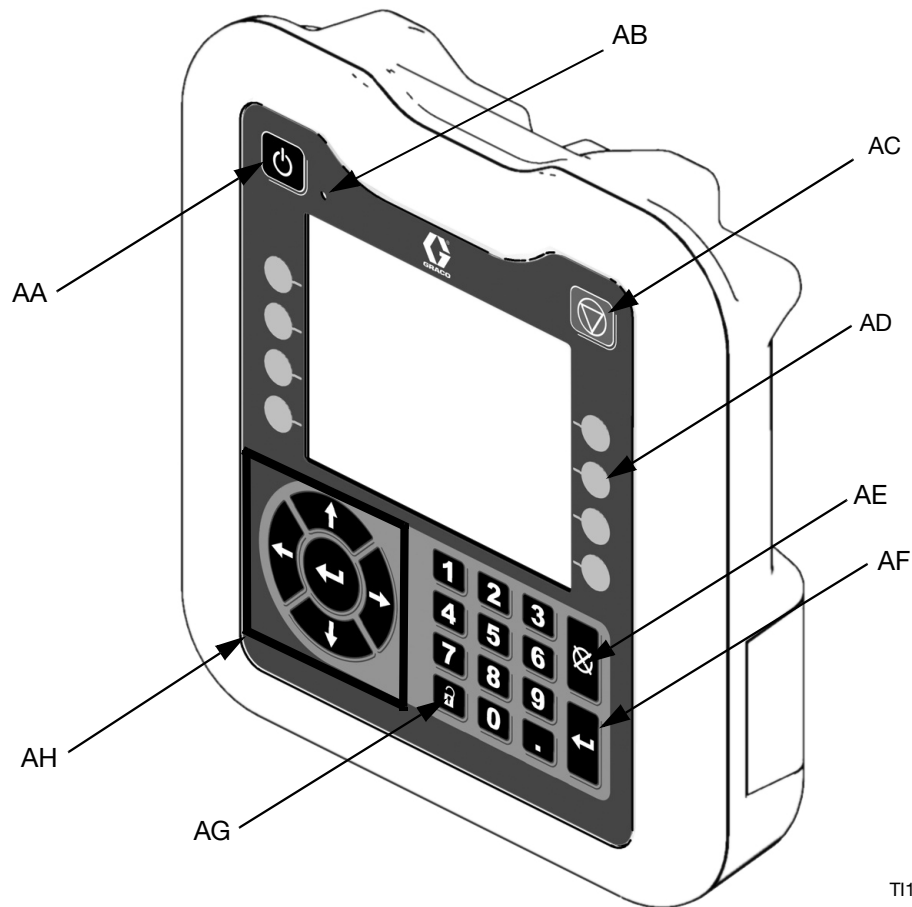

T112362a1

FIG. 3: ADM Component Identification - Front

### Buttons

Callout	Button	Function
AA	System enable/disable	Enables/disables system. When system is disabled, temperature control and dispense operation are disabled.
AB	System Status Indicator Light	Displays system status. See <b>System Status Indicator (AB) Conditions</b> on page 10 for details.
AC	Stop	Stop all system processes. Is not a safety or emergency stop.

Callout	Button	Function
AD	Soft Keys	Defined by application using ADM.
AE	Cancel	Cancel a selection or number entry while in the process of entering a number or making a selection.
AF	Enter	Acknowledge changing a value or making a selection.
AG	Lock/Setup	Toggle between run and setup screens. If setup screens are password protected, button toggles between run and password entry screen.
AH	Navigation	Navigate within a screen or to a new screen.

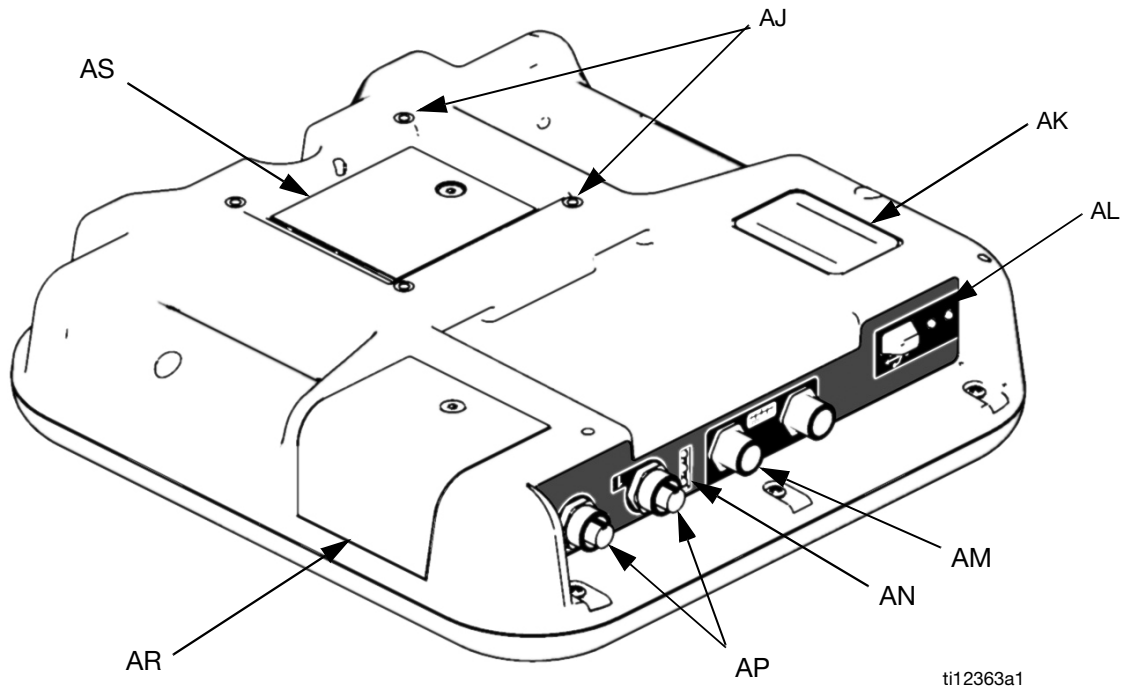

ti12363a1

**Fig. 4: ADM Component Identification - Rear**

**Key:**

- AJ Flat Panel Mount
- AK Model Number
- AL USB Module Interface
- AM CAN Cable Connections
- AN Module Status LEDs
- AP Accessory Cable Connections
- AR Token Access Cover
- AS Battery Access Cover

**System Status Indicator (AB) Conditions**

- Green Solid** - Run Mode, System On
- Green Flashing** - Setup Mode, System On
- Yellow Solid** - Run Mode, System Off
- Yellow Flashing** - Setup Mode, System Off

**ADM Module Status LEDs (AN) Conditions**

Module Status LED Signal	Description
Green on	System is powered up.
Yellow on	Communication in progress.
Red solid	ADM hardware failure.
Red flashing	Uploading software.

**USB Module Status LEDs (AL) Conditions**

Module Status LED Signal	Description
Green flashing	System is powered up.
Yellow on	Downloading information to USB
Green/Yellow Flashing	ADM is busy, USB cannot transfer information when in this mode

# Installation

All electrical wiring must be done by a qualified electrician and comply with all local codes and regulations.				

## Grounding

The equipment must be grounded to reduce the risk of static sparking and electric shock. Electric or static sparking can cause fumes to ignite or explode. Improper grounding can cause electric shock. Grounding provides an escape wire for the electric current.				

**EVR:** grounded through the power cord (customer supplied).

**Fluid supply containers:** follow local code.

**Object being dispensed:** follow local code.

**Solvent pails used when flushing:** follow local code. Use only conductive metal pails, placed on a grounded surface. Do not place the pail on a non-conductive surface, such as paper or cardboard, which interrupts grounding continuity.

**To maintain grounding continuity when flushing or relieving pressure:** hold metal part of the dispense valve firmly to the side of a grounded metal pail, then trigger the dispense valve.

## Power Requirements

The system requires a dedicated circuit protected with a circuit breaker.

Voltage	Phase	Hz	Current
200-240 VAC	1	50/60	41 A
480 VAC	3	50/60	18 A

## Connect Power

- Cut power cord wires to the following lengths:
  - Ground wire - 6.5 inches (16.5 cm)
  - Power wires - 3.0 inches (7.6 cm)
  - Add ferrules as necessary. See FIG. 5.

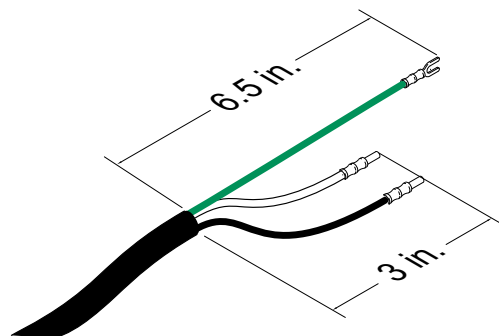

**FIG. 5: Power Cord**

- Remove the four screws to separate the EVR Frame Cover (T) and Power Disconnect Switch (C) from the EVR Frame (S) on the electrical driver.

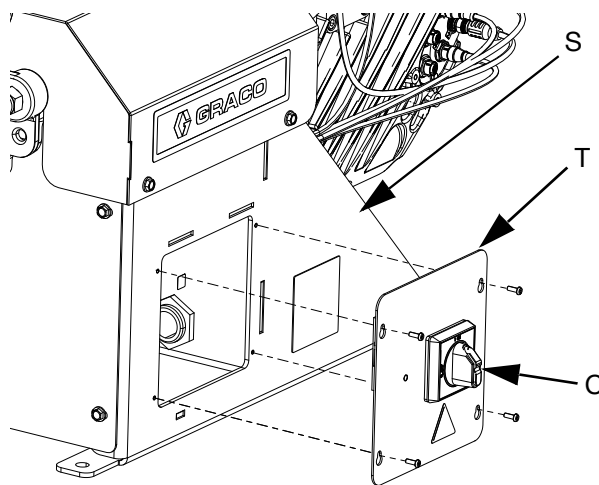

**FIG. 6: Remove EVR Frame Cover**

**NOTE:** Inside the EVR Frame (S), power wires are pre-installed to terminals 2T1 and 4T2 on the Disconnect Block (Z). Refer to FIG. 7 for the terminal locations.

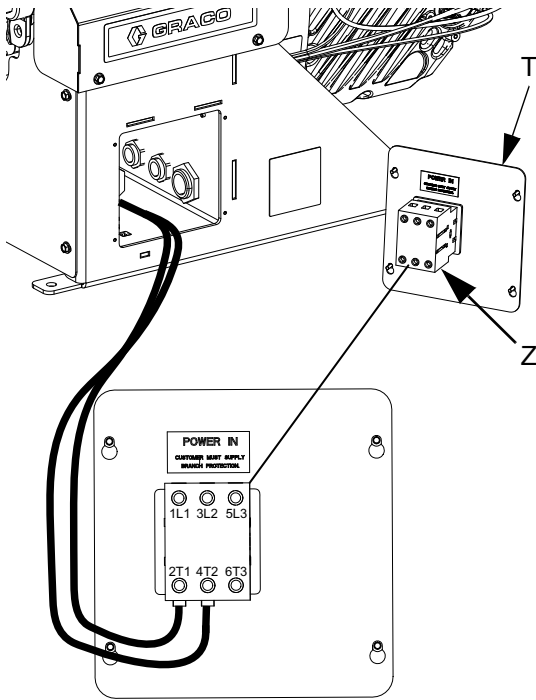

**FIG. 7: Terminal Connections**

3. Insert the power cord through the cord grip (strain relief) 3/4-14 NPT male, cable range 0.35-0.63 in. (8.9-16 mm), and into the EVR Frame (S).
4. Attach the ground wire to the ground terminal inside the EVR Frame (S) as shown in FIG. 8.

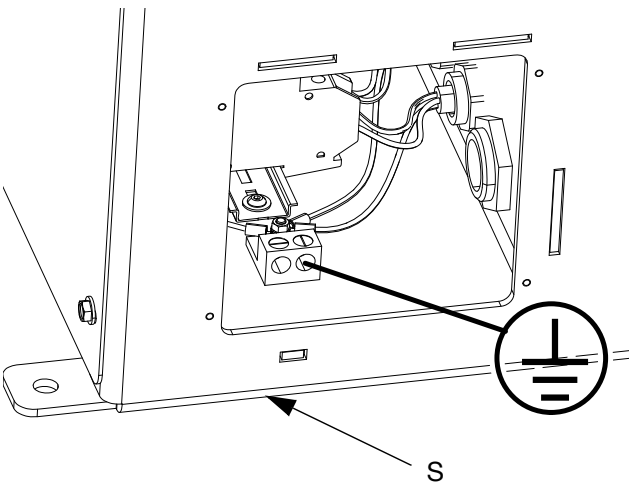
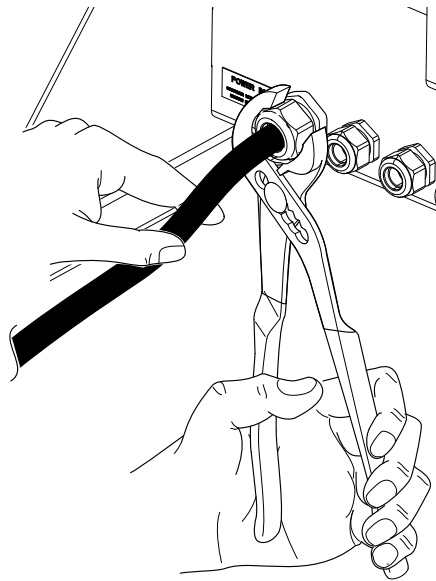

**FIG. 8: Attach Ground Wire**

5. Refer to FIG. 7 and connect the wires from the power cord into terminals 1L1 and 3L2.

**NOTE:** Do not attach the ground wire to the grounding lug locknut on the outside of the electric driver. See **Grounding** on page 11.

6. Place the power wires into the open area on either side of the Power Disconnect Switch (C) as space permits.
7. Reinstall the EVR Frame Cover (T) and Power Disconnect Switch (C) using the four screws removed in step 2.
8. Tighten the cord grip to securely hold the power cord in the EVR Frame (S).

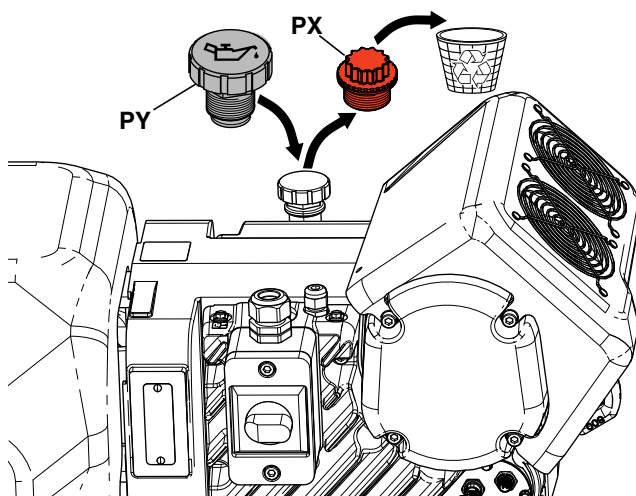

**FIG. 9: Tighten Cord Grip**

## Install Vented Oil Cap Before Using Equipment

The driver gear-box is shipped from the factory pre-filled with oil. The temporary unvented cap (PX) prevents oil leaks during shipment. This temporary cap must be replaced with the vented oil cap (PY), supplied with the equipment, before use.

**NOTE:** Prior to use, check oil level. Oil level should be half way up the sight glass.



**Fig. 10: Unvented and Vented Oil Caps**

# Setup

After placing the EVR in the desired area of operation:

**NOTE:** Make sure the EVR is placed on a level surface. See **Dimensions** on page 127 for space requirements.

1. Anchor the EVR to a fixed mounting location. See **Dimensions** on page 127.
2. Follow steps a through c to install pumps ordered separately for EVR systems configured without pumps. If the EVR is already configured with pumps, proceed to step 3.
  - a. Install inlet fittings onto the A and B pumps purchased separately.
  - b. Install the pumps onto the EVR. Use spring clamps (provided with pumps) to couple the pump to yoke adapters.
  - c. Install adapters into the pump outlets, then install outlet manifold assemblies and drain tubes.
  - d. Remove the plugs installed on the back of the A and B pumps, and install the pressure transducers as shown in FIG. 11.

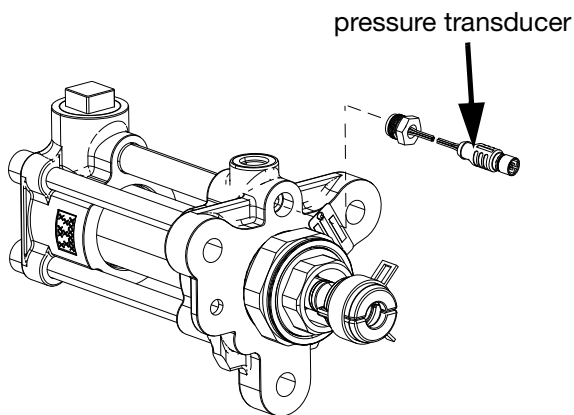

**FIG. 11**

- e. Install pressure transducers into port #6 on both A and B Electric Drivers (G). The A pressure transducer is marked with red tape, and the B pressure transducer is marked with blue tape.

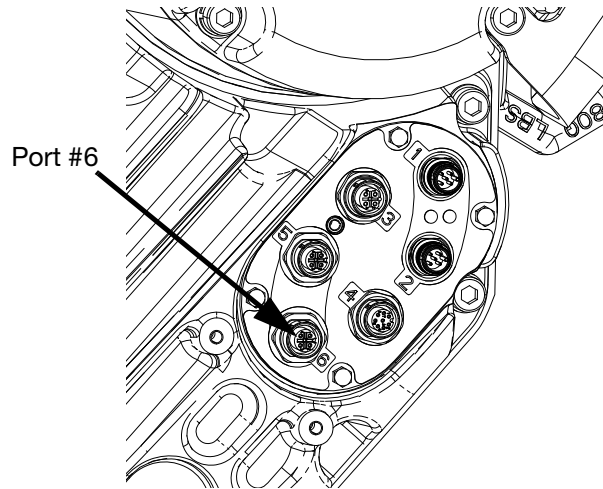

**FIG. 12: Electric Driver Port #6**

3. Connect the supply systems.
  - a. Install feed pumps for component A (Red) and B (Blue) supply drums.

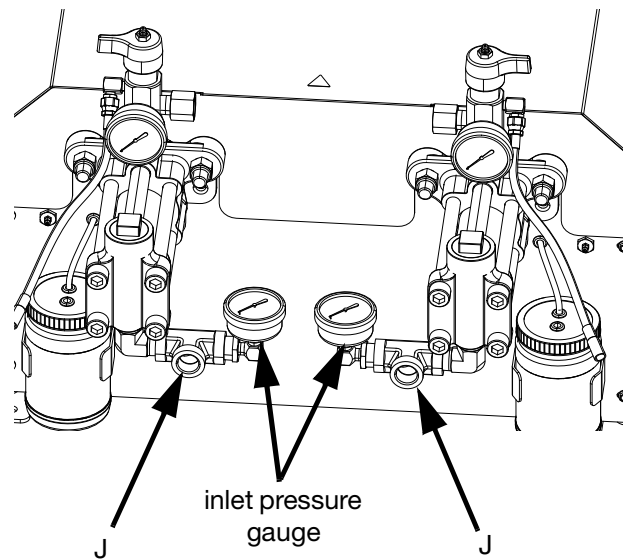

**FIG. 13**

2000 psi max

- b. Ensure the supply systems and, if applicable, the inlet regulators are off or set to zero pressure before connecting.

**NOTE:** Supply hoses from feed pumps should be 3/4 in. (19 mm) ID minimum.

- c. Assemble, connect and tighten the component B (Blue) inlet hose to the B Pump Inlet (J).

- d. Assemble, connect and tighten the component A (Red) inlet hose to the A Pump Inlet (J).
4. Attach the fluid outlet hoses to the Pump Outlets (K).

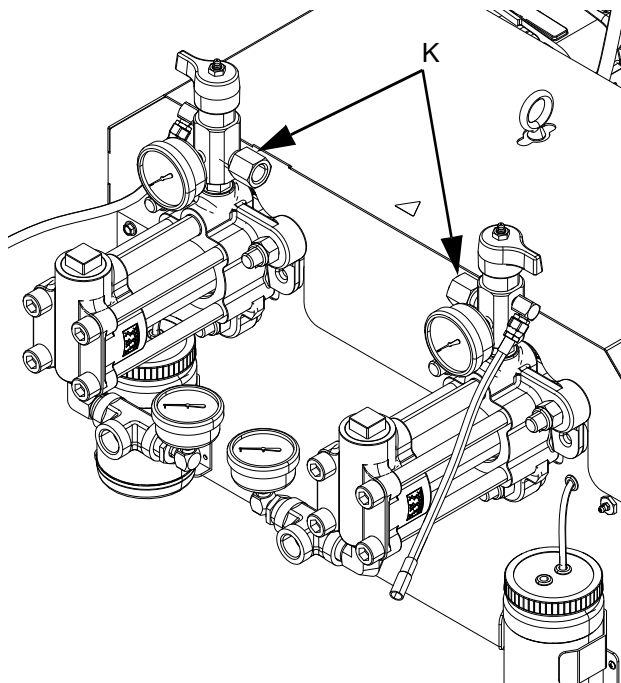

**FIG. 14**

5. Connect the outlet hoses to the dispense valve. Refer to your dispense valve component manual for complete installation instructions.
6. Pressure check the hoses. If there are no leaks, secure the outlet hoses together to protect them from damage.

## Flushing



To avoid fire and explosion, always ground equipment and waste container. To avoid static sparking and injury from splashing, always flush at the lowest possible pressure.

- Flush out old fluid with new fluid, or flush out old fluid with a compatible solvent before introducing new fluid.
- Use the lowest possible pressure when flushing.
- All fluid components are compatible with common solvents.
- To flush the entire system, circulate through the dispense valve and drain valve.

# Operation



## Startup

1. Use the supply systems to load the fluid.

**NOTE:** The EVR is tested with oil at the factory. Flush out the oil with a compatible solvent before dispensing.

- a. Check that all machine connections are tightened. See **Setup** on page 14.
- b. Verify both feed supply systems are connected to an air supply.
- c. Turn the Power Disconnect Switch (C) to the ON position.
- d. Verify the machine is ON and the System Status Indicator (AB) is solid green. See **System Status Indicator (AB) Conditions** on page 10.
- e. Turn both Outlet Drain/Relief Valves (P, R) to DISPENSE (pointing toward the outlet pressure gauges).

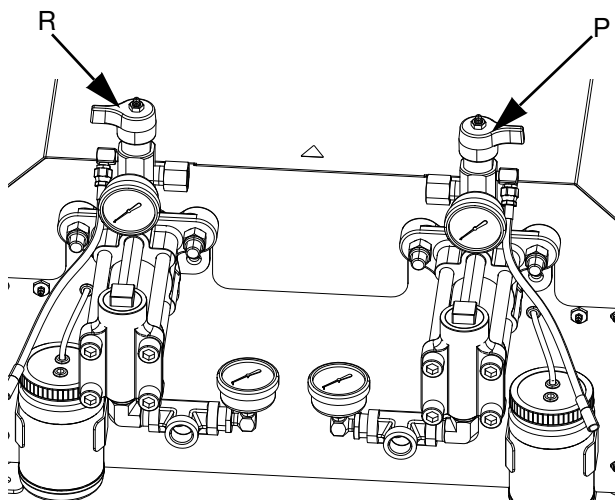

- f. Start the supply systems. See **Adjust Material Inlet Pressure** on page 18.



### Keep Components A and B Separate

Cross-contamination can result in cured material in fluid lines which could damage equipment or cause serious injury if injected or splashed on skin or in eyes. To prevent cross-contamination of the equipment's wetted parts, **never** interchange component A and component B parts.

- g. Use supply systems to load the system.
- h. To prime the pump, cycle the pump a few times or until air-free fluid dispenses. See **Home Run Screen** on page 36 for instructions on priming the pump through the ADM.





To prevent serious injury from splashing, dispense fluids at a low pressure.

- i. Hold the dispense valve nose piece, without a mixer installed, over two grounded waste containers. Leave the mixer off and trigger the dispense valve until both fluids flow freely from the nose piece without any air.
- j. With the valve closed, install the required mixer on the dispense valve. Refer to your dispense valve manual.



## Shutdown



1. Park the pumps. From the Home screen, press the  icon. Material will dispense. The pump will park automatically. Once the pump is parked, the pump will stop moving.
2. Press the enable/disable key on the ADM  to disable the EVR.
3. Turn the Power Disconnect Switch (C) to the OFF position.
4. Relieve fluid pressure from the supply system. See your appropriate supply system manual for instructions on relieving fluid pressure.
5. Perform the **Pressure Relief Procedure** on page 17.

## Pressure Relief Procedure

 Follow the Pressure Relief Procedure whenever you see this symbol.

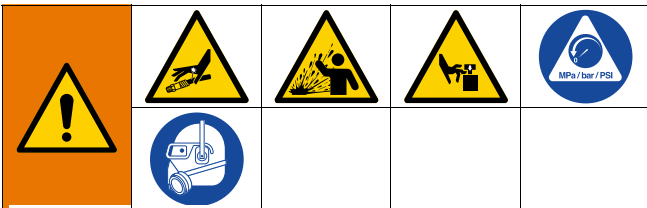

This equipment stays pressurized until pressure is manually relieved. To help prevent serious injury from pressurized fluid, such as skin injection, splashing fluid and moving parts, follow the Pressure Relief Procedure when you stop spraying and before cleaning, checking, or servicing the equipment.

**NOTE:** The fittings on the pressure relief hoses are zinc plated carbon steel. The hoses are cured with sulfur. Check your materials for compatibility with zinc plating and sulfur before reusing any material that passed through them, as it may inhibit curing.

1. Press the enable/disable key on the ADM  to disable the EVR, and verify it is inactive.

2. Relieve pressure and shut off the supply systems. See your appropriate supply system manual.
3. Turn the Outlet Drain/Relief Valves (P, R) to **PRES-SURE RELIEF/CIRCULATION** (pointing toward the drain hoses). Route the fluid to grounded waste containers or supply tanks. Ensure gauges read 0.

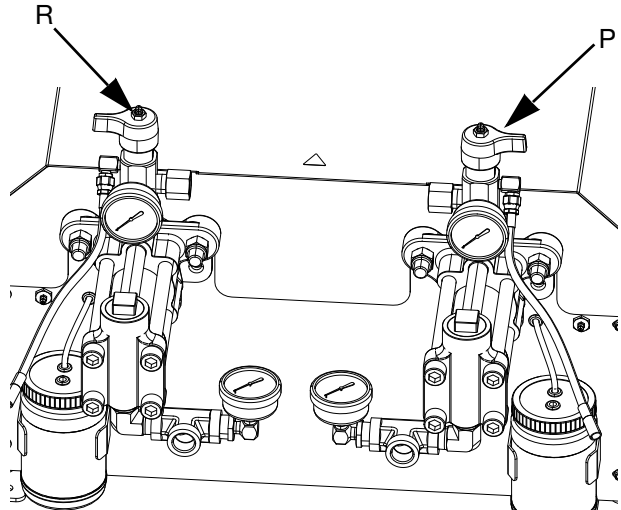

4. For models with a dispense valve with a safety lock, engage the dispense valve safety lock.

## Adjust Material Inlet Pressure



### NOTICE

Care must be taken when applying pressure to systems equipped with an inlet pressure regulator on the inlet assembly. Too much pressure could result in a burst hose. Read both operation and service manuals for the pump/ram supply system and the inlet pressure regulator prior to loading material to the EVR system.

Use the following procedure to adjust the fluid pressure to the system inlet. This process assumes that the supply system consisting of a supply pump and outlet hose has already been loaded and primed and is ready to provide material to the pump inlet.

1. Verify that the material supply pump does not provide material pressure in excess of the maximum fluid inlet pressure of 2000 psi (13.8 MPa, 138 bar).
2. Verify that there is no pressure in the material supply pump.
3. If used, verify both fluid inlet regulators are functioning properly. See the regulator component manual for detailed operating instructions.
4. Adjust both inlet regulators (if used) so that there is no air pressure on them and that the regulator pressure gauge reads zero.
5. Place a grounded container at the outlet of the relief lines from the manifold assemblies and secure the lines in place.
6. Turn the pressure relief valves on the manifold to the drain/recirculation position.

7. Gradually increase the air pressure to the supply pump to provide no more than 2000 psi (13.8 MPa, 138 bar).
8. If a fluid inlet regulator is used, slowly increase the air pressure on the inlet regulator to allow material to flow through the pump and out of the drain hose. The required material pressure will vary depending on the material viscosity and flow rate.
9. Once material is flowing from the drain hose, slowly decrease pressure on the inlet regulator until flow stops.
10. Gradually increase pressure to the inlet regulator until material begins to flow again.
11. When material begins to flow out of the drain port, close the pressure relief valves.

**NOTE:** Record the pump inlet pressure gauge reading. Use this pressure as a starting point for adjusting the material feed pressure to meet application requirements.

**NOTE:** As a general rule for high viscosity materials, the dispense pressure must exceed the material inlet pressure by 2 to 3 times. Therefore, if the maximum dispense pressure is 2500 psi (17 MPa, 172 bar), the inlet pressure should be no more than 1250 psi (9 MPa, 86 bar). For lower viscosity, flowable materials, the dispense pressure should exceed the inlet pressure by 3-4 times. Use only enough feed pressure to adequately feed the EVR pumps. The minimum feed pressure is 70 psi (0.48 MPa, 4.83 bar).

12. The inlet pressure regulator is not self relieving. Reducing the material pressure at the regulator will not effect the pressure reading until the accumulated down stream pressure is relieved. Perform the **Pressure Relief Procedure** on page 17.

# Maintenance



**NOTE:** See the Maintenance section in your component manuals for maintenance instructions for specific system components. See **Related Manuals** on page 3.

Task	Schedule
Change break-in oil in a new unit	After first 200,000 - 300,000 cycles
Inspect fluid lines for leaks	Daily
Grease Outlet Drain/Relief Valves (R,P) with Fusion® grease (117773)	Weekly
Clean dispense valve mix chamber ports regularly, see dispense valve manual	See dispense valve manual
Clean dispense valve check valve screens, see dispense valve manual	See dispense valve manual

## Grease Outlet Drain/Relief Valves with Fusion Grease (117773)

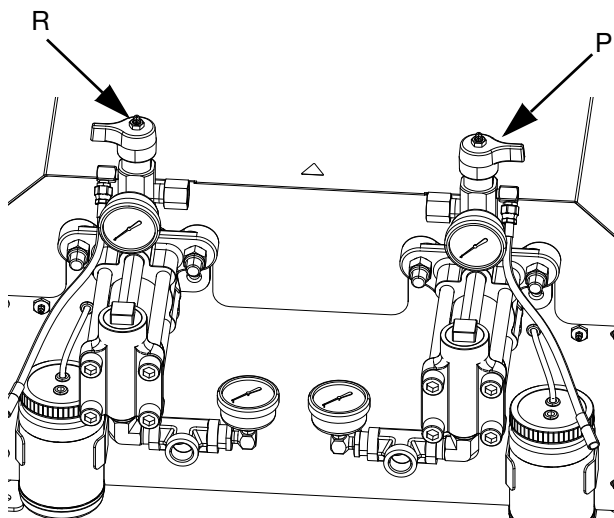

## Preventative Maintenance Schedule



The operating conditions of your particular system determine how often maintenance is required. Establish a preventative maintenance schedule by recording when and what kind of maintenance is needed, and then determine a regular schedule for checking your system.

## Check Oil Level

Check the oil level in sight glass (FC). (See FIG. 15.) The oil level should be near the halfway point of the sight glass when the sprayer is not running. If oil is low, open fill cap (FB) and add Graco Part No. 16W645 ISO 220 silicone-free synthetic EP gear oil. See FIG. 15.

The oil capacity is approximately 2.0 - 2.2 quarts (1.9 - 2.1 liters). **Do not overfill.**

**NOTICE**

Only use oil with Graco part number 16W645. Any other oil may not lubricate properly and can cause damage to the drive train.

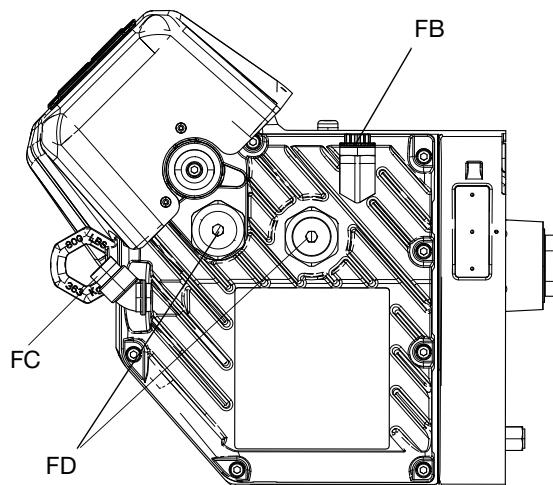
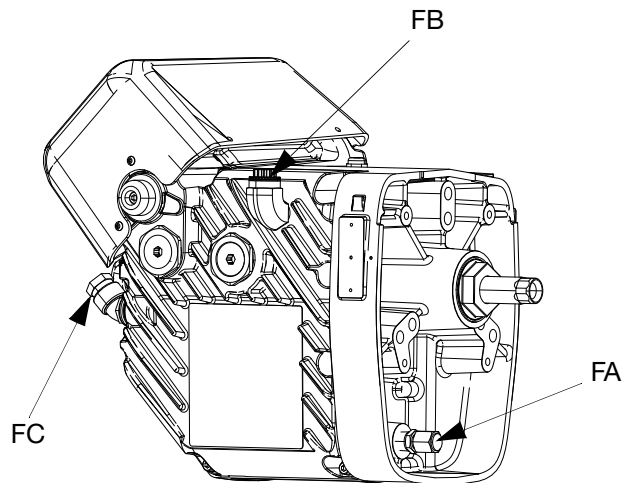

**FIG. 15: Sight Glass and Oil Fill Cap**

## Change the Oil

**NOTE:** Change the oil after a break-in period of 200,000 to 300,000 cycles. After the break-in period, change the oil once per year.

1. Perform the **Shutdown** procedure on page 17.
2. Place a minimum 2 quart (1.9 liter) container under the oil drain port. Remove the oil drain plug (FA). Allow all oil to drain from the driver.
3. Reinstall the oil drain plug (FA). Torque to 18-23 ft-lb (25-30 N•m).
4. Open the fill cap (FB) and add Graco Part 16W645 ISO 220 silicone-free synthetic EP gear oil. Check the oil level in the sight glass (FC). (See FIG. 15.) Fill until the oil level is near the halfway point of the sight glass. The oil capacity is approximately 2.0 - 2.2 quarts (1.9 - 2.1 liters). **Do not overfill.**
5. Reinstall the fill cap.



## Bearing Pre-Load

See FIG. 15. The bearing pre-loads (FD) are factory set and are not user adjustable. Do not adjust the bearing pre-loads.

## Calibrate the Electric Driver



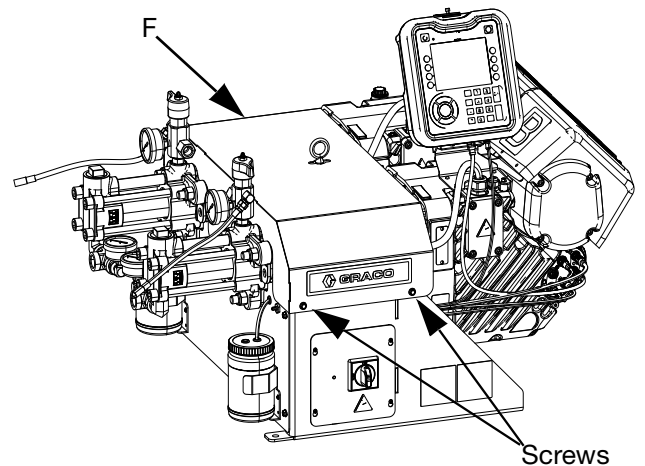

1. Park the pumps. From the Home screen, press the  icon. Material will dispense. The pump will park automatically. Once the pump is parked, the pump will stop moving.
2. Turn the Power Disconnect Switch (C) to the OFF position.
3. Perform the **Pressure Relief Procedure** on page 17.
4. Loosen the four screws and remove the Pump Shroud (F).

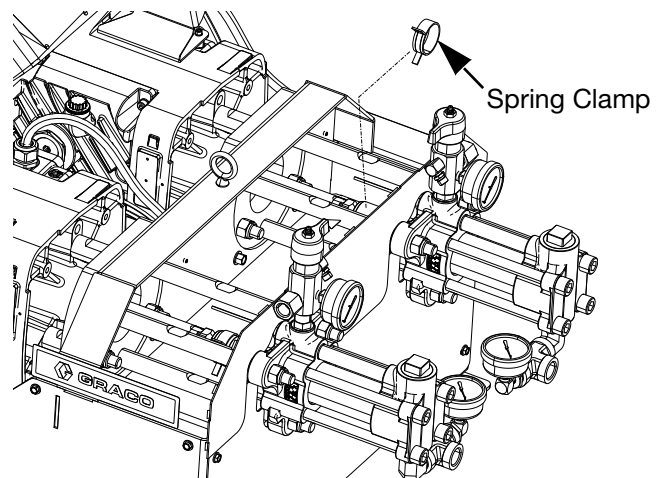

5. Remove the spring clamps coupling the pump to the yoke adapters. The driver will need to cycle freely during the calibration process.



6. Turn the Power Disconnect Switch (C) to the ON position.
7. Navigate to Maintenance Screen 1 on the ADM (see page 58). Press  to enter Calibration mode.

8. Press the  icon to begin calibration. Wait for the calibration process to finish.
  - a. The driver output shaft will cycle back and forth slowly over the course of several minutes.
  - b. Mid-way through the auto-calibration process, the shaft will pause.
  - c. The shaft will cycle five or six times at a faster pace.
9. Verify the calibration process has been completed successfully. Successful calibration is indicated by

the green check mark  displayed on the screen.

10. Exit the calibration screen.
11. Use the Jog function to move the yoke in position for coupling the pumps (see page 58).
12. Turn the Power Disconnect Switch (C) to the OFF position.
13. Couple the pumps to the yoke adapter using the spring clamps removed previously.
14. Replace the Pump Shroud (F).
15. Turn the Power Disconnect Switch (C) to the ON position and resume operation.

## ADM - Battery Replacement and Screen Cleaning



### Battery Replacement

A lithium battery maintains the ADM clock when power is not connected.

To replace the battery:

1. Perform the **Shutdown** procedure on page 17.
2. Disconnect power to the ADM. This can be done by removing the CAN cable from the bottom of the ADM.
3. Remove battery access cover.

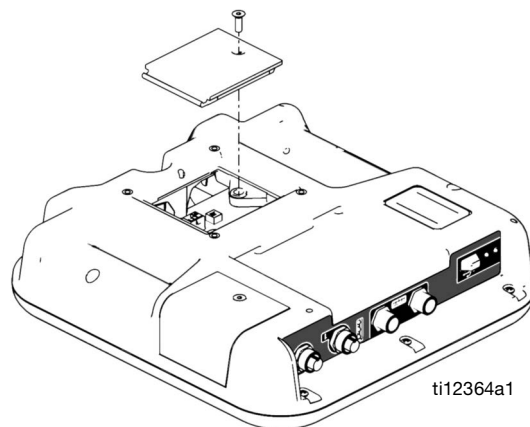

4. Remove the old battery and replace with a new CR2032 battery.
5. Properly dispose the old lithium battery according to local codes.
6. Replace battery access cover.
7. Connect the power to the ADM and reset the clock through **System Setup Screen 4**. See **System Setup Screen 4** on page 47.

### Cleaning

Use any alcohol-based household cleaner, such as glass cleaner, to clean the ADM. Spray on the rag then wipe ADM. Do not directly spray the ADM.

## Grease Cup Maintenance

Frequency of greasing intervals is dependent on material being pumped. As a basic schedule, lubricate pump with grease after 250 gallons of product ( five drums of 55 gallon pails) has been passed through the pump.

If the grease has become hardened, remove the hardened materials or grease. Shorten the intervals between greasing the pump.

If the grease remains clear and free of material, intervals between greasing the pump can be increased.

### To Grease the Pump:

1. Locate the grease fitting (A) mounted to the back cover near the pump that is being greased.

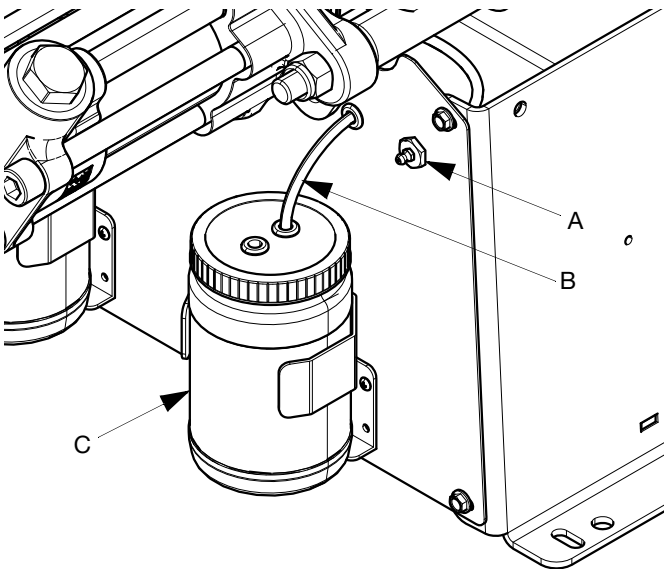

**FIG. 16**

2. Attach grease gun to the grease fitting (A). Pump new grease into fitting until fresh grease is observed discharging from grease relief tube (B) into the grease reservoir bottle (C).
3. Repeat for the other side.

# Troubleshooting

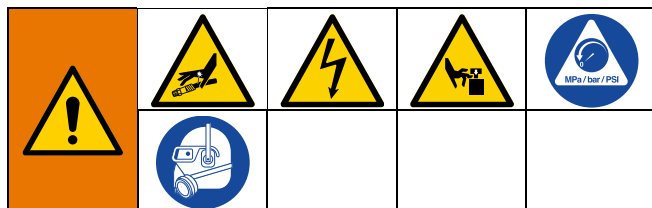

**NOTE:** For Online help, visit <http://help.graco.com> for causes and solutions to each error code.

1. Follow **Pressure Relief Procedure**, page 17.
2. Check all possible problems and causes before disassembling.
3. Turn the Power Disconnect Switch (C) OFF.

Try the recommended solutions in the order given for each problem, to avoid unnecessary repairs. Also, determine that all circuit breakers, switches, and controls are properly set and wiring is correct before assuming there is a problem.

Problem	Cause	Solution
<b>General</b>		
Advanced Display Module completely dark	No power	Verify the Power Disconnect Switch (C) is ON
	Loose connection	Tighten 5-pin cable on the Advanced Display Module
	Bad Advanced Display Module	Replace the Advanced Display Module
No or incorrect amount of material dispensed from either side	Ball Valve closed (if Installed)	Open supply ball valve.
	Supply empty	Add fluid
	Air in material	Prime the machine
Significant material leaking from pump seal	Pump shaft worn and/or shaft seal worn	Remove the pump shaft assembly and reinstall read pump rebuild kit
Material dispensed incorrect volume	System is calling for wrong amount, or the flow rate is incorrect	Verify the system is calling for the correct amount, and the flow rate is correct.
	Check valve malfunction	Remove the check valve; clean or replace as necessary
	Piston worn or broken	Replace the piston
The wrong pressure is displayed on the ADM/CGM	Incorrect pressure transducer is being used	Verify that the correct pressure transducer is being used. Change if necessary.  Low Inlet Pressure Kit: Use 16P289 pressure transducer High Inlet Pressure Kit: Use 15M669 pressure transducer  Outlet: Use 15M669 pressure transducer
	Bad pressure transducer	Replace the pressure transducer

Problem	Cause	Solution
<b>Proportioning System</b>		
Proportioning pump does not hold pressure when stalled	Pump piston or intake valve leaking	<ol style="list-style-type: none"> <li>1. Observe gauge to determine which pump is losing pressure.</li> <li>2. Determine in which direction the pump has stalled by observing which directional valve indicator light is on.</li> <li>3. Repair the valve.</li> </ol>
Material imbalance	Inadequate flow from pump;	Increase fluid supply to proportioning pump: <ul style="list-style-type: none"> <li>• Use minimum 3/4 in. (19 mm) ID supply hose, as short as practical</li> </ul>
		Clean inlet strainer screen
		Worn pump inlet valve ball/seat or gasket
Erratic pump movement	Pump cavitation	Feed pump pressure is too low. Adjust pressure to maintain 100 psi (0.7 MPa, 7 bar) minimum.
Pump output low	Obstructed fluid hose or dispense valve; fluid hose ID too small	Open, clear; use hose with larger ID.
	Worn piston valve or intake valve in displacement pump	See pump manual 3A0019.
	Inadequate feed pump pressure	Check feed pump pressure and adjust to 100 psi (0.7 MPa, 7 bar) minimum.



## EVR Error Codes

Error Code	Type	Code Description	Cause	Solution
A1A_	Alarm	Low Current Z_	Fault heat element	Check heater resistance and resistance to ground. Replace fault heater.
A2A_	Advisory	Low Current Z_	Fault heater element	Check heater resistance and resistance to ground. Replace fault heater.
A3A_	Advisory	High Current Z_	Heater element is defective	Replace heater element.
			Heater element is shorted	Check wiring to the heater element to ensure no bare wires are touching and that no wires are shorted to ground.
A2VX	Deviation	Low Current Fan	Fault fan	Check fan wires to make sure that the connections are correct.
				Replace fan if necessary.
A3VX	Deviation	High Current Fan	Fan is drawing too much current	Verify there is not an air obstruction at the inlet/outlet of the enclosure.
				Verify nothing is preventing fan rotation.
				Replace fan if necessary.
A4A_	Alarm	High Current Z_	Heater element is defective	Replace heater element.
			Heater element is shorted	Check wiring to the heater element to ensure no bare wires are touching and that no wires are shorted to ground.
A4N_	Alarm	High Current Motor _	Inlet pressure too high, causing retract stroke to require too much torque	Reduce inlet supply pressure.
			Pump sizes too large for motor to drive at the operating pressure	Reduce pump size.
			Wrong pump sizes are programmed into the system	Verify the pump sizes in the setup screen are correct for the pumps that are installed on system.
Reduce outlet flow rate or outlet operating pressure.				

<b>Error Code</b>	<b>Type</b>	<b>Code Description</b>	<b>Cause</b>	<b>Solution</b>
A7A_	Alarm	Unexpected Current Z_	Unexpected current flow to the heat element	Fault heater element. Check heater resistance and resistance to ground. Replace heater element.
				Faulty AMZ, Replace AMZ.
A8A_	Alarm	No Current Z_	Power not getting to heating element	Check fuse on the AMZ that the error element is connected to.
				Check that electrical connector on the heated hose is plugged into the AMZ.
				Check continuity of pins on electrical connector at AMZ end of heated element. See heated element manual for impedance measurements and pin outs. Replace hose if readings are too high.
CAA_	Advisory	Comm. Error Advanced Display _	Motor Control Module (3MCP) is unable to communicate with Advanced Display Module (ADM)	Verify CAN cable is plugged in.
				Remove and reconnect CAN cable, taking care not to cross thread the connector nut.
CAC_	Advisory	Comm. Error Gateway _	Motor Control Module (3MCP) is unable to communicate with Communications Gateway Module (CGM)	Verify CAN cable is plugged in.
				Remove and reconnect CAN cable, taking care not to cross thread the connector nut.
CAM_	Alarm	Comm. Error Motor Control Module _	Advanced Display Module (ADM) is unable to communicate with Motor Control Module (3MCP)	Verify CAN cable is plugged in.
				Remove and reconnect CAN cable, taking care not to cross thread the connector nut.
CAP_	Advisory	Comm. Error Paired Motor _	Motor Control Module (3MCP) is unable to communicate with the Pair Motor Control Module (3MCP)	Verify CAN cable is plugged in.
CAFX	Advisory	Comm. Inlet pressure & Recirculation Module	System is unable to communicate with the fluid control module	Verify CAN cable is plugged in.
				Remove and reconnect CAN cable, taking care not to cross thread the connector nut.

<b>Error Code</b>	<b>Type</b>	<b>Code Description</b>	<b>Cause</b>	<b>Solution</b>	
CAT_	Advisory	Comm. Error _____ Tank Stand	System unable to communicate with tank stand	Verify CAN cable is plugged in.	
				Remove and reconnect CAN cable, taking care not to cross thread the connector nut.	
CAVX	Advisory	Comm. Error Voltex DMV	System is unable to communicate with Voltex dynamic mix valve (DMV)	Verify CAN cable is plugged in.	
				Remove and reconnect CAN cable, taking care not to cross thread the connector nut.	
CACX	Advisory	Comm. Error Gateway	Motor Control Module (3MCP) lost communication with automation controller	Verify fieldbus cable is properly connected.	
				Verify host is communicating.	
CAK_	Advisory	Comm. Error Auto Multi-Zone D_	No AC power to the AMZ	Verify AMZ MZLP4 is turned on by confirming disconnect switch of the heat box is in the ON position.	
				AC disconnected switch broken	Disconnect AMZ MZL4 from AC power. Check wiring to switch. If wiring is good, replace the AC disconnect switch of the heat box.
				Faulty AMZ MZLP4 control board	Replace AMZ MZLP4 control board.
CALX	Advisory	Comm. Error I/O Daughter Board	No AC power to the AMZ DB	Verify AMZ DB is turned on by confirming disconnect switch of the heat box is in the ON position.	
				AC disconnected switch broken	Disconnect AMZ DB from AC power. Check wiring to switch. If wiring is good, replace the AC disconnect switch of the heat box.
				Faulty AMZ DB control board	Replace AMZ DB control board.
CBAX	Alarm	ADM Comm. Error	The ADM lost communication with the Heat Controller DB	Verify CAN cable is plugged into the network.	
				Carefully check for cross-threaded CAN connections on the ADM and AMZ. Yellow LED on the ADM and AMZ board should be flashing. If not, replace CAN cable(s).	

<b>Error Code</b>	<b>Type</b>	<b>Code Description</b>	<b>Cause</b>	<b>Solution</b>
CBGX	Alarm	Gateway Comm. Error	The Gateway lost communication with the Heat Controller DB	Verify CAN cable is plugged into the network.
				Carefully check for cross-threaded CAN connections on the Gateway and AMZ. Yellow LED on the Gateway and AMZ board should be flashing. If not, replace CAN cable(s).
				Replace Gateway Module.
CBH_	Alarm	AMZ Comm. Error D_	Heat Controller DB lost communication with the AMZ on dial position _	Verify AMZ CAN cable is plugged in the network.
				Carefully check for cross-threaded CAN connections on the AMZ. Yellow LED on the AMZ board should be flashing. If not, replace CAN cable(s).
				Replace AMZ Module.
CCCX	Advisory	Comm. Error Gateway _	Motor Control Module (3MCP) lost communication with automation controller	Verify fieldbus cable is properly connected.
				Verify host is communicating.
CCFX	Alarm	Fieldbus Comm. Error	Heat controller DB lost communication with automation controller	Verify fieldbus cable is properly connected.
				Verify host is communicating.
F3N_	Advisory	Unable to Maintain Flow Rate _	Pump is unable to deliver the desired flow rate	Reduce flow rate.
				Increase pump sizes.
				Measure line voltage. Low line voltage may reduce maximum operating flow rate.
F4CX	Alarm	Recirculation Flow Exceeds Max Flow	The flow rate requested by the recirculation exceeded the max flow rate (26 cycle per pump)	Reduce the flow rate so that the recirculation flow rate is below the max flow rate.
F4C_	Alarm	Recirculation Flow Exceeds Max Flow	The flow rate requested by the recirculation exceeded the max flow rate (26 cycle per pump)	Reduce the flow rate so that the recirculation flow rate is below the max flow rate.
F4RX	Alarm	Recipe Flow Exceeds Max Flow	The flow rate requested by the recipe exceeded the max flow rate (26 cycle per pump)	Reduce the flow rate so that the recipe flow rate is below the max flow rate.

<b>Error Code</b>	<b>Type</b>	<b>Code Description</b>	<b>Cause</b>	<b>Solution</b>
F4PX	Alarm	Purge Flow Exceeds Max Flow	The flow rate requested by the purge exceeded the max flow rate (26 cycle per pump)	Reduce the flow rate so that the purge flow rate is below the max flow rate.
F4GX	Alarm	Gel Flow Exceeds Max Flow	The flow rate requested by the gel timer exceeded the max flow rate (26 cycle per pump)	Reduce the flow rate so that the gel timer flow rate is below the max flow rate.
L1T_	Deviation	Tank Sensor Failure_	Bad level sensor(s)	Replace level sensor(s)
L2T_	Deviation	Low Material_	Tank low on material	Fill tanks with material.
			Loose/broken connection	If the tanks appear to have plenty of material, check to make sure the level sensor(s) is connected to the proper port and that the cord is not damaged.
			Bad level sensor(s)	Replace level sensors(s).
L3T_	Deviation	High Material Level_	Defective fill valve	If the tanks appear to have plenty of material, check to make sure the level sensor is connected to the proper port and that the cord is not damaged.
				Replace fill valve is leaking.
			Bad level sensor	Replace level sensor.
L6T_	Deviation	Auto Refill Timeout_	No material is actually being fed	Make sure the feed pumps are operating properly.
			Loose level sensor connection	Check for loose or disconnected wires or plugs.
			Bad level sensor	Replace level sensor.
MA0_	Advisory	Pump Cycles Exceeds Limit _	The number of pump cycles since last reset has exceeded the limit	Performed desired maintenance and reset the pump cycles in the maintenance screen.
MEDX	Advisory	Valve Cycles Exceeds Limit	The number of dispense valve cycles since last reset has exceeded the limit	Performed desired maintenance and reset the pump cycles in the maintenance screen.
MGFX	Advisory	Clean Fan Filter	The machine is requesting fan filter cleaning	Perform cleaning on the fan filter.

<b>Error Code</b>	<b>Type</b>	<b>Code Description</b>	<b>Cause</b>	<b>Solution</b>
P1D_	Alarm	Low Pressure Outlet _	Pressure exceeds user-defined limit	Inspect for leaks in fluid path.
				Increase operating pressure by increasing flow rate and/or restriction in the hose and valve.
				Decrease user-defined pressure limit.
P1F_	Alarm	Low Pressure Inlet _	Pressure exceeds user-defined limit	Inspect for leaks in fluid path.
				Increase operating pressure by increasing feed pressure and/or restriction in the feed hoses.
		Out of material	Decrease user-defined pressure limit.	
P2D_	Deviation	Low Pressure Outlet _	Pressure exceeds user-defined limit	Verify material supply.
				Inspect for leaks in fluid path.
				Increase operating pressure by increasing flow rate and/or restriction in the hose and valve.
P2F_	Deviation	Low Pressure Inlet _	Pressure exceeds user-defined limit	Decrease user-defined pressure limit.
				Increase operating pressure by increasing feed pressure and/or restriction in the feed hoses.
		Out of material	Verify material supply.	
P3D_	Deviation	High Pressure Outlet _	Pressure exceeds user-defined limit	Inspect for hardened material or obstructions to flow.
				Attempt to purge material at a reduced flow rate.
				Reduce operating pressure by reducing flow rate and/or restriction in the hose and valve.
				Increase user-defined pressure limit.

Error Code	Type	Code Description	Cause	Solution
P3F_	Deviation	High Pressure Inlet _	Pressure exceeds user-defined limit	Inspect for hardened material or obstructions to flow.
				Attempt to purge material at a reduced flow rate.
				Reduce operating pressure by reducing flow rate and/or restriction in the hose and valve.
				Increase user-defined pressure limit.
P4D_	Alarm	High Pressure Outlet _	Pressure exceeds user-defined limit	Inspect for hardened material or obstructions to flow.
				Attempt to purge material at a reduced flow rate.
				Reduce operating pressure by reducing flow rate and/or restriction in the hose and valve.
				Increase user-defined pressure limit.
P4F_	Alarm	High Pressure Inlet _	Pressure exceeds user-defined limit	Inspect for hardened material or obstructions to flow.
				Attempt to purge material at a reduced flow rate.
				Reduce operating pressure by reducing flow rate and/or restriction in the hose and valve.
				Increase user-defined pressure limit.
P6D_	Alarm	Pressure Sensor Error Outlet _	Loose or bad sensor connection to Motor Control Module	Check to make sure that the pressure sensor is properly connected to the Motor Control Module (3MCP).
			Faulty sensor	Replace the Pressure Sensor.
P6F_	Deviation	Pressure Sensor Error Inlet _	Loose or bad sensor connection to Motor Control Module	Check to make sure that the pressure sensor is properly connected to the Motor Control Module (3MCP).
			Faulty sensor	Replace the Pressure Sensor.

Error Code	Type	Code Description	Cause	Solution
P7D_	Alarm	Pressure Imbalance High _	Dispense line is clogged	First try purging fresh material through the system. Then relieve pressure and check for cured material or obstructions in the dispense valve.
			Orifice restrictions sized incorrectly	Adjust orifice restrictions to balance pressure of A and B materials.
			Out of material	Verify material supply.
			Pressure imbalance is defined too low	Increase pressure imbalance amount from the Setup screen of the Advanced Display Module (ADM).
P9D_	Alarm	High Pressure Outlet _	Pressure exceeds system limit	Inspect for hardened material or obstructions to flow.
				Attempt to purge material at a reduced flow rate.
				Reduce operating pressure by reducing flow rate and/or restriction in the hose and valve.
P9F_	Alarm	High Pressure Inlet _	Pressure exceeds system limit	Inspect for hardened material or obstructions to flow.
				Reduce operating pressure of the inlet pumps.
T1A_	Alarm	Low Temperature Z_	Zone has reached setpoint but dropped below setpoint and cannot recover	Check resistance of heater roads. Refer to manual for resistance.
				Adjust the temp Offset Error in the setup screen.
T2A_	Advisory	Low Temperature Z_	Zone has reached setpoint but dropped below setpoint and cannot recover	Check resistance of heater roads. Refer to manual for resistance.
				Adjust the temp Offset Error in the setup screen.
T3A_	Advisory	High Temperature Z_	Element continues to raise above the setpoint	Defective RTD. Replace.
			RTD not in correct location on element	See manual to find correct location of RTD on element.
			Temperature reading has risen too high	Adjust the temp Offset Error in the setup screen.
T3TX	Deviation	High Temperature Transformer	Transformer temperature is too high	Cool down transformer.



Error Code	Type	Code Description	Cause	Solution
T4A_	Alarm	High Temperature Z_	Element continues to raise above the setpoint	Defective RTD. Replace.
			RTD not in correct location on element	See manual to find correct location of RTD on element.
			Temperature reading has risen too high	Adjust the temp Offset Error in the setup screen.
T4N_	Alarm	High Temperature Motor _	Cooling fans not working properly	Ensure cooling fans are clear of obstructions and operating properly.
T4TX	Alarm	High Temperature Transformer	Transformer temperature is too high	Cool down transformer.
T6A_	Alarm	Temperature Sensor Error Z_	No reading from the RTD of the heat zone	Check the wired connections to make sure that RTD is wired correctly.
				Defective RTD. Replace.
T6TX	Deviation	Temperature Sensor Error Transformer	No reading from the RTD of the transformer	Check the wired connections to make sure that RTD is wired correctly.
				Defective RTD. Replace.
T8A_	Alarm	No Temperature Rise Z_	The zone temperature does not change	Check fuse on the AMZ that the error element is connected to.
				Check that electrical connector on the heated hose is plugged into the AMZ.
				Defective heater road in element. Replace.
T9A_	Alarm	Over Temperature Switch Error Z_	The zone over temperature switch is wires are unplugged	Plug back in.
			The zone temperature is too high	Cool pump down.
			Fault over temperature switch	Replace over temperature switch.
T9TX	Deviaiton	Runaway Temperature Transformer	Fan filter is clogged/dirty	Clean fan filter. If needed, replace fan filter.
V1N_	Alarm	Low Voltage Motor _	AC voltage is too low	Check wire connections and verify line voltage is within specification.

Error Code	Type	Code Description	Cause	Solution
V2H_	Alarm	Low Voltage D_	Incoming line to line voltage has dropped below 175V	Verify incoming power is correct gauge for current draw and verify incoming power lines are securely attached to disconnect.
V4H_	Alarm	High Voltage D_	Incoming line to line voltage has increased above 265V	For 3 phases with neutral have qualified electrical verify neutral wire.
V4N_	Alarm	High Voltage Motor _	AC voltage is too high	Verify line voltage is within specification.
V6H_	Alarm	Wiring Error D_	Wrong wiring of the power source to the AMZ	Verify incoming power is wired to the disconnect correctly per the manual.
WBN_	Alarm	Encoder Error Motor	Encoder not plugged in	Ensure encoder connector is fully plugged into the circuit board inside the driver.
			Faulty encoder	Replace encoder.
WMN_	Alarm	Controller Fault Motor	Faulty circuit board	Replace motor control circuit board.
WNKX	Deviation	Improper Expansion Dial Position	The heat modules have been detected not to have the same heat type. Which is caused by an improper dial position on the expansion heat.	Verify that the dial positions are correct.  <b>Warm Melt:</b> Main Dial Position - Dial Position 1 Expansion Dial Position - Dial Position 2  <b>Hot Melt:</b> Main Dial Position - Dial Position 3 Expansion Dial Position - Dial Position 4
W5N_	Deviation	Encoder Calibration Motor	Encoder not calibrated	Calibrate the Encoder from the maintenance screen of the Advanced Display Module (ADM).
WSNX	Alarm	Invalid Recipe	Entry into recipe is not correct or zero	Enter a valid value
WVCX	Deviation	Motor Fault	Over Torque	Cycle power. Increase ramp up time. Cycle power to unit  Clean mixer. Cycle power to unit.
			No power to motor	Make sure that motor has power. Check power supply if cycle power is needed.

# Advanced Display Module (ADM) Operation

When main power is turned on by turning the Power Disconnect Switch (C) to the ON position, the splash screen will be displayed until communication and initialization is complete.



To begin using the ADM, the machine must be on and enabled. To verify the machine is enabled, verify the System Status Indicator Light (AB) is illuminated green, see FIG. 3 on page 9. If the System Status Indicator Light is not green, press the ADM Power On/Off (AA)

button . The System Status Indicator Light will illuminate yellow if the machine is disabled.

Perform the following tasks to fully setup your system.

1. Set the date, time, and language settings. See **Advanced Screen 1**, page 57.
2. Set units of measure. See **System Setup Screen 1**, page 45.
3. Enable/disable system features. See **System Setup Screen 2**, page 46, **System Setup Screen 3**, page 46, and **System Setup Screen 4**, page 47.
4. Define pump information. See **System Setup Screen 1**, page 45.
5. Define recipes. See **Recipe Definition Screen 1**, page 44.
6. If desired, view/reset counters. See **Maintenance Screen 1**, page 58.
7. Enable/disable integration features. See **Integration Setup Screen**, page 62.

# ADM Screen Overview



## Home Run Screen

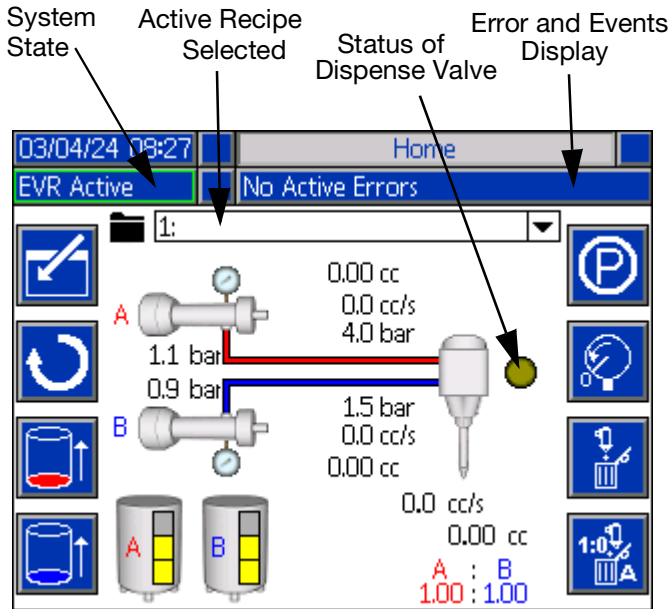

The home screen is the first screen displayed when the ADM is turned on. Here you can monitor the actual flow rate, actual amount dispense, and the current fluid pressure on the outlets of the A and B pump. If installed, the inlet pressure of the pumps will be displayed.

**NOTE:** While the machine is dispensing, the system will show actual ratio in the bottom right-hand corner instead of the setpoint.

This screen also displays any active errors or events as well as the active recipe selected.

Pressing the  icon will enter the home screen and allow the user to select the active recipe and the desired purge flow rate.

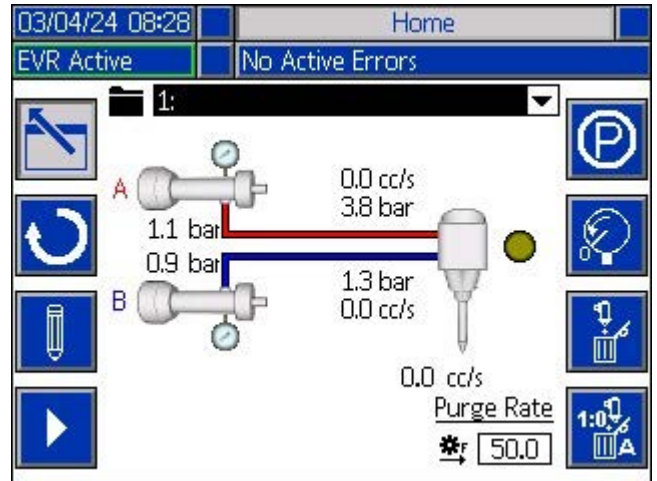





To select a recipe, use the navigation keys to highlight the active recipe bar. Then press the Enter button

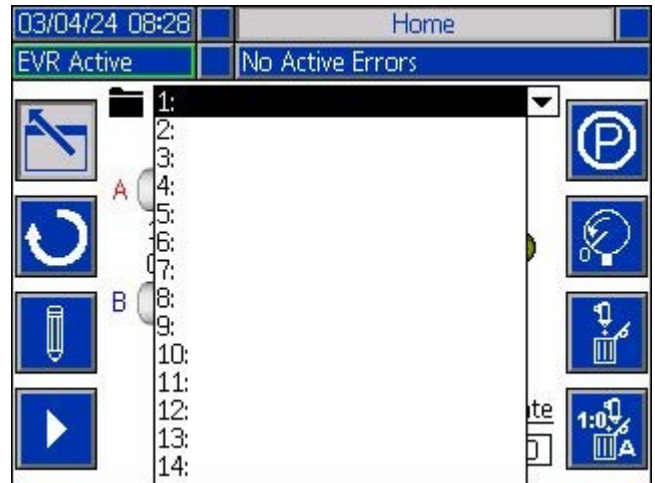

to open a drop down menu where the desired recipe can be selected.

Recipes can also be selected remotely. For discrete, see **I/O Integration** on page 68, and for fieldbus, see **PLC Automation Inputs** on page 70 and **PLC Automation Outputs** on page 81.





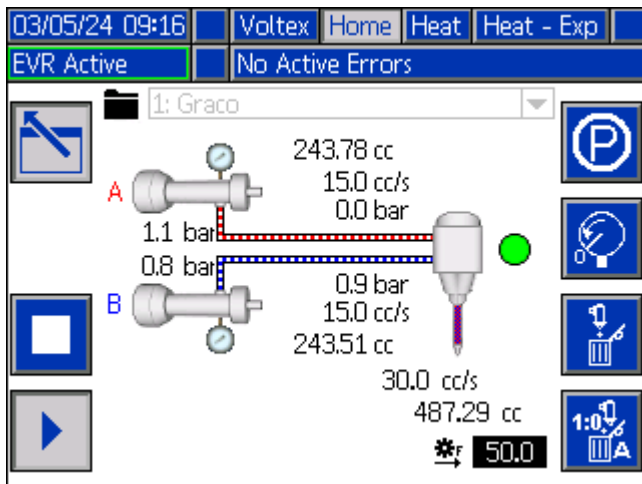

To initiate a recipe dispense, press the  icon to enter edit mode on the Home Run Screen, then press the  icon to start the recipe dispense. To stop the recipe dispensing process, press the  icon.

Recipes can also be initiated remotely. If using a discrete signal, see **I/O Integration** on page 68, and if using a fieldbus, see **PLC Automation Inputs** on page 70 and **PLC Automation Outputs** on page 81.

**NOTE:** The system will automatically stop a dispense once a shot is completed. If dispensing an operator dispense, the  icon must be pressed to finish the dispense.







Along the right side of the home screen, there are icons

that will allow the user to park , de-pressurize , purge , base purge , and recirculate  the system.

**NOTE:** The system must be active to access these icons. The only icon that can be selected when the system is inactive is the de-pressurize icon.

**NOTE:** When the valve type selected on **System Setup Screen 1**, page 45, is MD2, the base purge feature becomes disabled. The MD2 valve's design prevents individual opening of the two components.



**NOTE:** When recirculation is installed, the recirculation feature is activated, and the recirculation icon  will appear on the **Home Run Screen**. See **System Setup Screen 4**, page 47, for information on installing recirculation.

**Park:** Press the park icon  to initiate the parking feature. When the park icon is pressed, the icon will turn gray , and the system will drive the pump towards the park position. Once the pump has reached the park position, the icon will return to blue , which indicates that parking is complete.

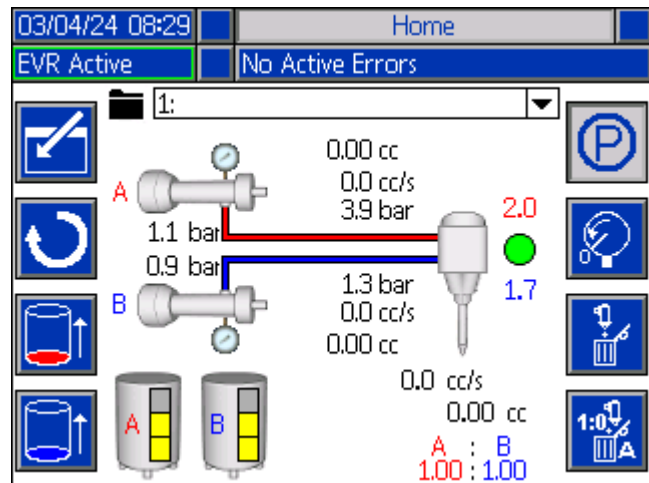

**NOTE:** Press the parking icon  at any point during the parking process to stop the system parking feature.

**NOTE:** The red number shown above the valve status indicates the remaining travel distance of the red pump, and the blue number shown below the valve status indicates the remaining travel distance of the blue pump.

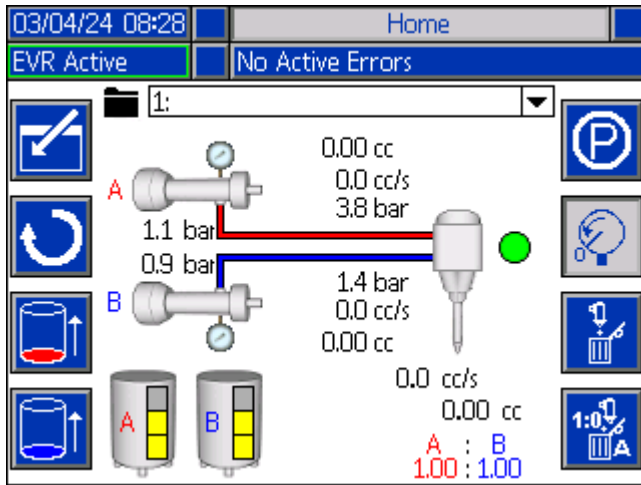

**De-Pressurize:** Press the de-pressurize icon  to initiate the de-pressurization feature. When the de-pressurize icon is pressed, the icon will turn gray , and the system will open the dispense valve, which will relieve pressure in the pump lines. Once all pressure has been relieved in the pump lines, press the de-pressurize icon  to close the dispense valve and stop the de-pressurization feature.





**Purge:** Press the purge icon  to initiate the purge feature and purge material from the pumps. When the purge icon is pressed, the icon will turn gray , and the system will open the dispense valve and run both pumps on ratio at the purge rate. Press the purge icon  again to close the dispense valve and stop the pumps.

**NOTE:** To adjust the purge rate, see **System Setup Screen 3**, page 46. The purge rate can also be

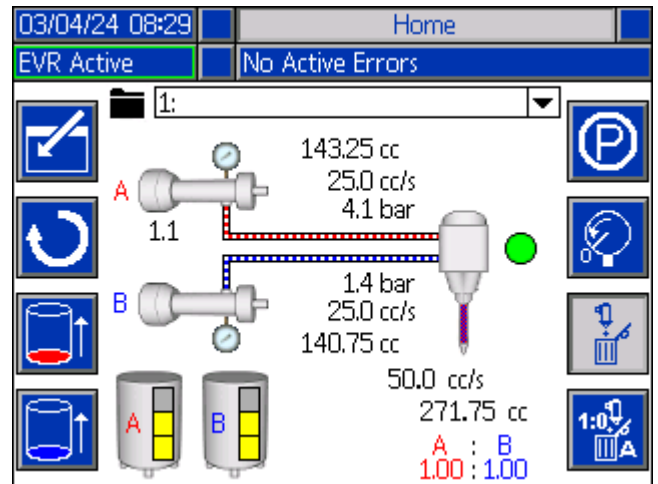
changed by pressing the  icon on the home screen and selecting the purge rate variable located on the bottom right-hand corner of the screen, below the purge rate.





**Base Purge:** Press the base purge icon  to initiate the base purge feature. When the base purge icon

is pressed, the icon will turn gray , and the system will open the dispense valve and purge material from one pump while the other pump enters a park state. Once parked, only the base purge pump will remain operational. To stop the base purge, press the

base purge icon  again to close the dispense valve and stop the pumps.

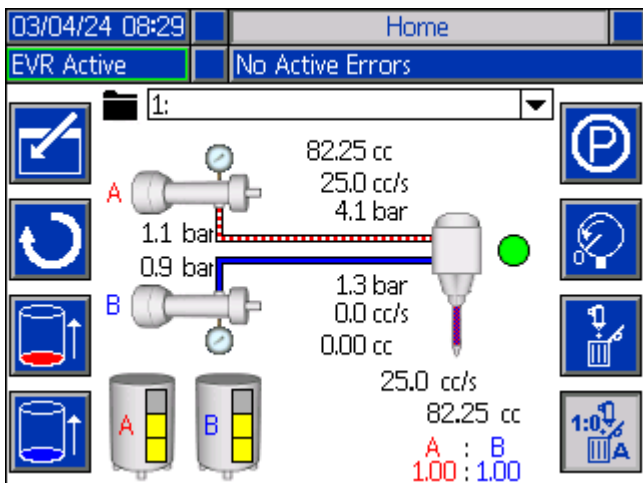
**NOTE:** The letter located in the bottom right-hand corner corresponds to the pump that is purging material. The selected pump can be changed on **System Setup Screen 3**, page 46.





**Recirculation:** Press the recirculation icon  to initiate the recirculation feature. When the recirculation

icon is pressed, the icon will turn gray , and the system will recirculate the material through both pumps by running the pumps at the desired pump flow rates.

The pump flow rates can be set on **System Setup Screen 4**, page 47. If the recirculation valves are set to Automatic on **System Setup Screen 4**, page 47, the system will open the recirculation valves.

To stop the recirculation feature, press the recirculation

icon  again to close the recirculation valves and stop the pumps.

**NOTE:** The letter in the middle of the  icon indicates which pump will be recirculating when the recirculation icon is pressed. If there is no letter shown in the middle of the icon, both pumps will recirculate material. See **System Setup Screen 4**, page 47, to select which pump(s) to recirculate when the recirculation feature is enabled.

**NOTE:** If the recirculation mode is set to timer on **System Setup Screen 4**, page 47, the time remaining for the recirculation to complete will be shown below the  icon. This applies whether the system is in the on or off state.

**NOTE:** If the recirculation mode is set to timer on **System Setup Screen 4**, page 47, dispensing a recipe or activating another feature during the off interval of the

recirculation timer, the recirculation button  must be pressed again to restart the recirculation timer.

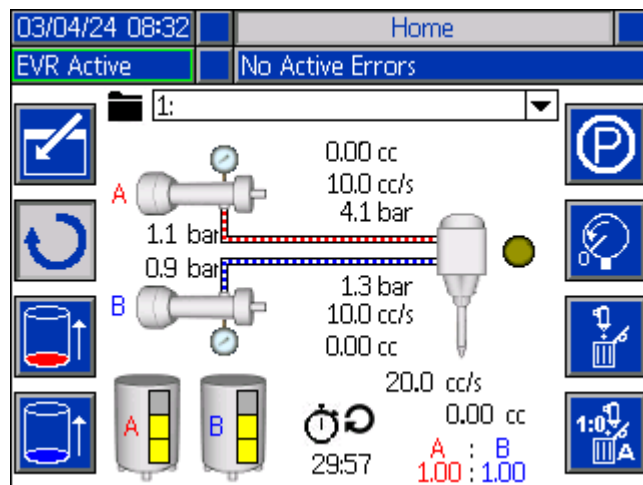



**Gel Timer:** If enabled in **System Setup Screen 3**, page 46, the gel timer will display the remaining time before

the next gel shot under the  icon.

To start the gel timer, the system must be active and a recipe must have been dispensed. If certain features (Park, De-pressurization, Purge, Base Purge, or Recirculation) are active, or the system is transitioning to an inactive state, the gel timer will be stopped and the process will need to be repeated in order to start the gel timer countdown again.

If a recipe is dispensed while the gel timer is counting down, then the gel timer will reset and the count down will restart after the recipe is completed.

**NOTE:** During a gel shot dispense, the  icon will be gray to indicate a gel shot is active. To cancel a gel shot, press the  icon.

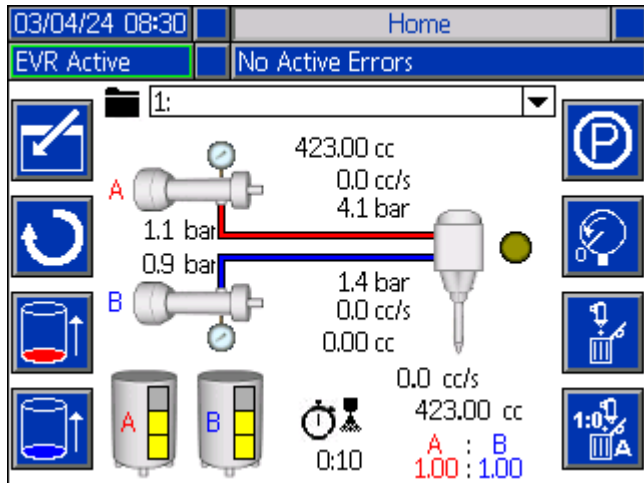



### Tank Stand Status Information

**NOTE:** The tank stand information and icons will only be shown when the tank stand is connected to the EVR network.

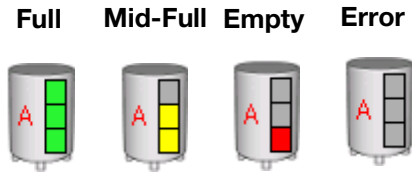
**Tank Status Fill Levels:** These icons display the fill level of each of the tanks.



**Tank Refill:** Press  or  to initiate a tank refill. If a tank is already filling, press either button to abort the filling operation.

**NOTE:** When the tank reaches full capacity while refilling, the refill process will automatically end and the refill valve will close.

**NOTE:** If the refill is canceled or halted due to an error, the user must re-initiate the refill to resume the refill operation.

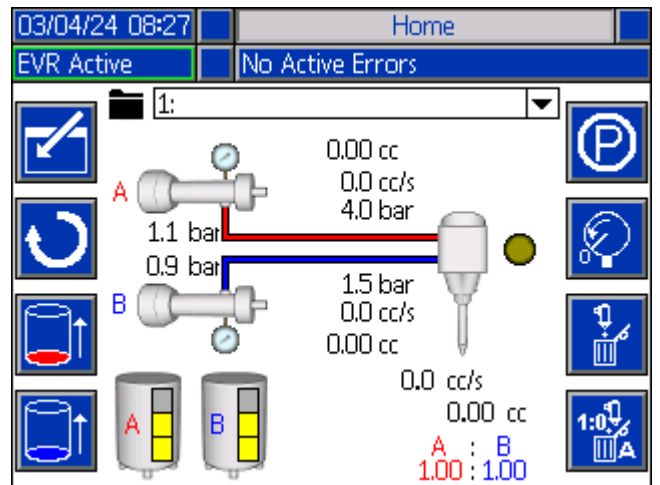



## Heat Run Screens

Use the arrows on the ADM directional keypad (AH) to navigate to the Heat run screen.

**NOTE:** The heat box is made up of one Automatic Multi-Zone (AMZ) controller. An additional AMZ can be added for expansion zones.

**NOTE:** The Heat run screens are only visible when the heat box is connected to the EVR network. If an expansion AMZ is on the network, the Heat Expansion screen will be visible.

To configure and set up the heat zone(s), see the **Heat Setup Screens**, page 49.

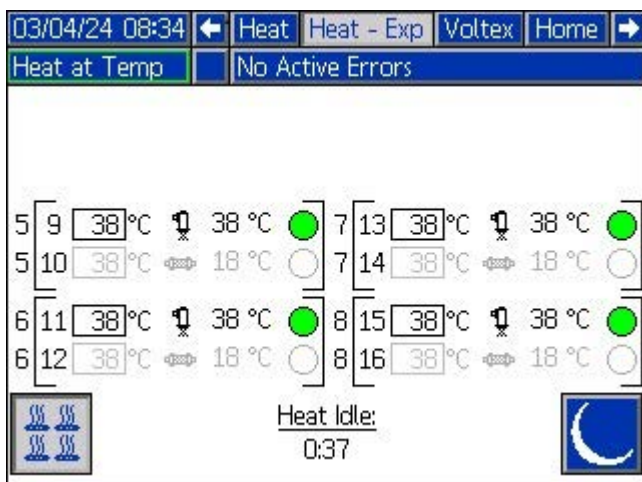
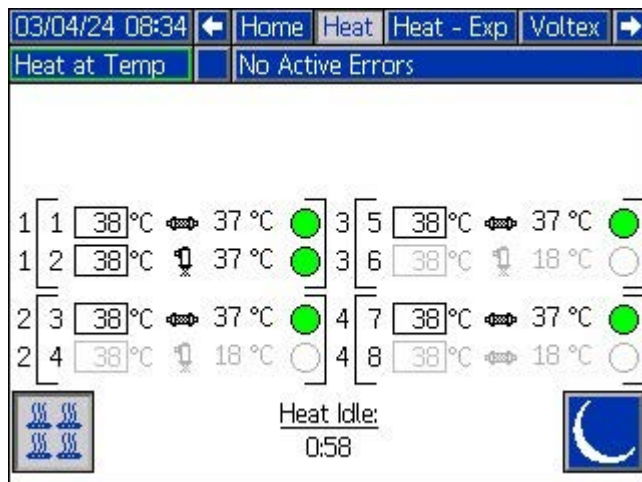

**NOTE:** To utilize a specific zone, the zone must be enabled on the Heat Setup Screens. If the zone is grayed out, that zone is currently not enabled. See the **Heat Setup Screens**, page 49, for instructions on enabling the desired zones.

**NOTE:** The temperature units can be configured as either Celsius (°C) or Fahrenheit (°F). To make changes to the temperature units, see the **Heat Setup Screens**, page 49.







**NOTE:** The Heat Idle time remaining and Longest Heat-soak time remaining will be displayed on the screen

between the  and  icons. See **Heat Setup Screens**, page 49, for more information on setting up the Heat Idle Timer and Heatsoak Time remaining.

For each zone, the number outside the left bracket is the connector number. The number just inside the left bracket is the zone number.

The temperature reading inside the box is the zone set-point temperature. This is the temperature the controller heats the zone to when the zone is turned on. When the system is placed in setback, the temperature displayed in the box is the setback value.

The Zone Type Heat Symbols in the middle of the brackets on the screen correspond to the current zone type to which the zone is configured. Below is the list of the zone type heat symbols.

Zone Type Heat Symbol	
	Hose
	Valve
	Manifold
	PGM
	Flowmeter
	Press Regulator



The number to the right of the zone type heat symbol represents the actual temperature of the zone. The temperature unit used is the same as the zone's set-point/setback temperature unit.

The zone heat state is indicated by the circle next to the actual temperature. There are six different colors used for the zone heat indicators, each representing a specific state.



Color	Description
Green	Zone is at temperature.
Yellow	Zone is in setback.
Yellow to Green	Zone is warming up. <b>NOTE:</b> Zone is in heatsoak when the circle status starts as yellow, then progresses clockwise to green as the heatsoak timer counts down to zero.
Green to Red	Zone has a deviation/advisory.
Red	Zone has an alarm.
White	Zone is turned off.

To turn on heat, press the  icon. At any time,

press the  icon again to turn the heat back off.

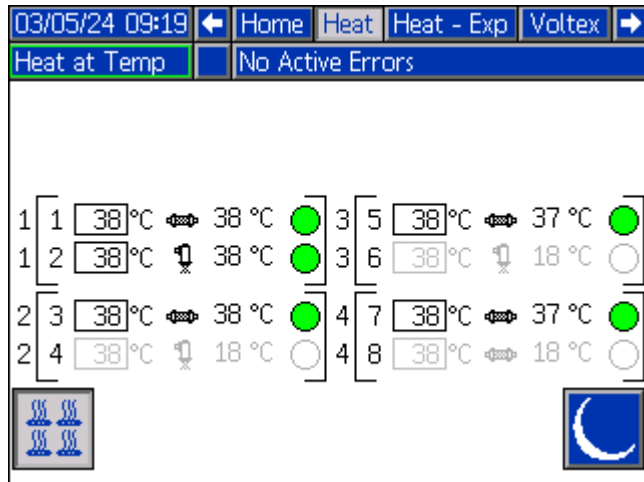
**NOTE:** If the system heat is not already active, press the enable/disable key on the ADM  to automatically initiate heating. If heat does not automatically initiate, manually press the  icon to turn on the heat.



Press the  icon when the heat icon appears gray  to enter the system into setback mode. To

return the system to normal heat setpoint operation, press the  icon again.

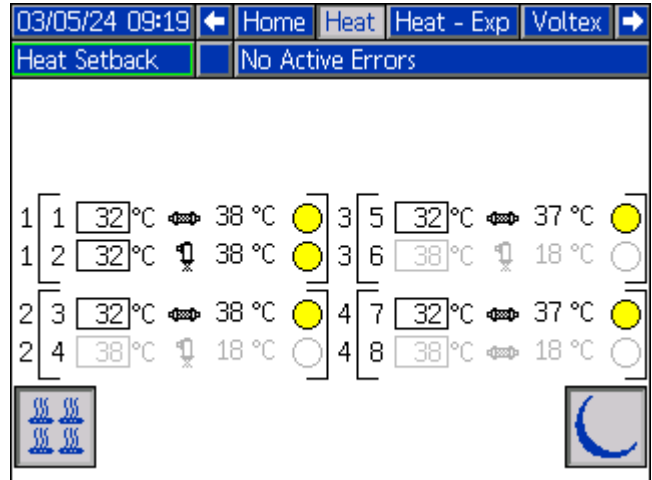

## Votex Dynamic Mix Valve Run Screen

Use the arrows on the ADM directional keypad (AH) to navigate to the Voltex run screen.

**NOTE:** This screen will only be displayed if the Voltex dynamic mix valve is connected to the EVR Network. For instructions on setting up a Voltex dynamic mix valve, see **System Setup Screen 3**, page 46.

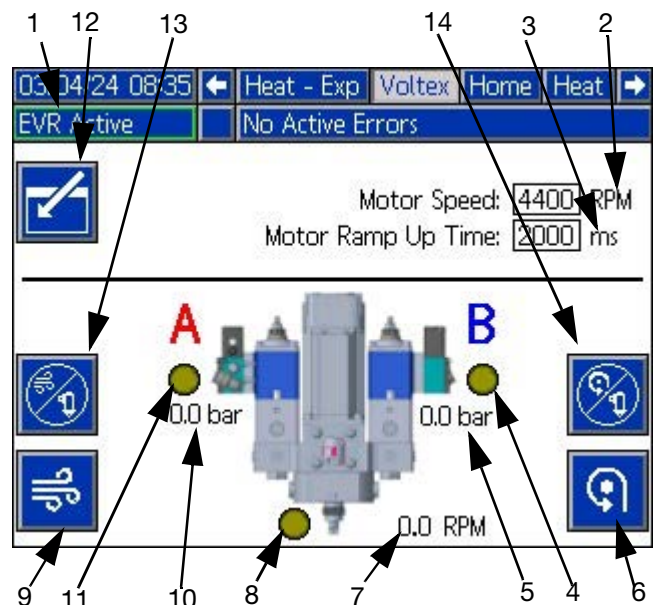

1. **System State:** Green frame with Active indicated means the system is ready to run. Amber frame with System Off indicated means system is off.
2. **Motor RPM Setpoint:** The RPM's that the motor will run at.
3. **Motor Ramp Up Time:** This changes the amount of time in milliseconds the motor takes to get to the RPM setpoint. NOTE: 100ms is the fastest acceleration and 9000ms is the slowest acceleration. The goal is to try and prevent breaking mixers with a slower acceleration. Example: 500ms = half a second to get to the RPM setpoint of 4400 RPM.
4. **(B) Valve Status:** Icon turns green when the dispensing system turns on the valve signal. Icon turns gold when dispensing system is off.
5. **(B) Valve Pressure:** If a pressure transducer kit is installed, the text will appear on the screen and display the pressure. There is no error for the transducer being unplugged.
6. **Manual Motor:** This button allows the motor to be turned on by the ADM at the RPM setpoint.
7. **Motor Actual RPM:** Shows what speed the motor is at during the ramp period. It is not direct feedback from the motor.
8. **Air nucleation valve indicator:** Icon turns green if air nucleation is enabled and the valve is open. Icon turns gold when it is off.
9. **Air Purge button:** Will open the air nucleation valve indefinitely to blow out the material in the mixer
10. **(A) Valve Pressure:** If a pressure transducer kit is installed, the text will appear on the screen and display the pressure. There is no error for the transducer being unplugged.
11. **(A) Valve Status:** Turns on when the dispensing system turns on the valve signal.
12. **Edit Mode:** Select to enter or exit the editing mode for the screen. Icon is gray when in edit mode and blue when off.
13. **Air Nucleation Disable for Dispensing:** Press this button to stop the air nucleation from running while dispensing. The icon turns grey to signal that the air nucleation has been disabled for dispensing. To re-enable the air nucleation for dispensing, press the button again. Every time a dispense occurs with the air nucleation disabled, an ECAA error will be placed into the events. See **EVR Error Codes** starting on page 25 for more information.
14. **Motor Spinning Disable for Dispensing:** Press this button to stop the motor from spinning while dispensing. The icon turns grey to signal that the motor has been disabled for dispensing. To re-enable the motor for dispensing, press the button again. Every time a dispense occurs with the motor disabled, an ECMA error will be placed into the events. See **EVR Error Codes** starting on page 25 for more information.

## Index Menu





From the home screen, press the  button to access the index screen. This screen provides access to the following chapters:



- Recipe Definition
- Setup
- Advanced
- Maintenance
- Diagnostics
- Shot Log
- Errors/Events
- Integration Screens



**NOTE:** Various sub-chapters are available for Setup, Errors/Events, and Integration; depending on the modules connected to the EVR network. After pressing the desired chapter icon, use the arrows on the ADM directional keypad (AH) to navigate between the sub-chapters and chapters.

## Recipe Definition Screens

On the Index screen, press the  icon to navigate to the recipe definition screen. Use the  arrow on the ADM directional keypad (AH) to navigate to the recipes chapter, then use the  and  arrows to scroll through the screens.

To edit a screen, press the  icon. When finished editing, press the  icon to save any changes.

## Recipe Definition Screen 1

This screen allows users to create and edit recipes. From here, users are able to edit the flow rate, shot size and calibration of the selected recipe. There are two options available for the shot size, including operator mode and volume (cc).

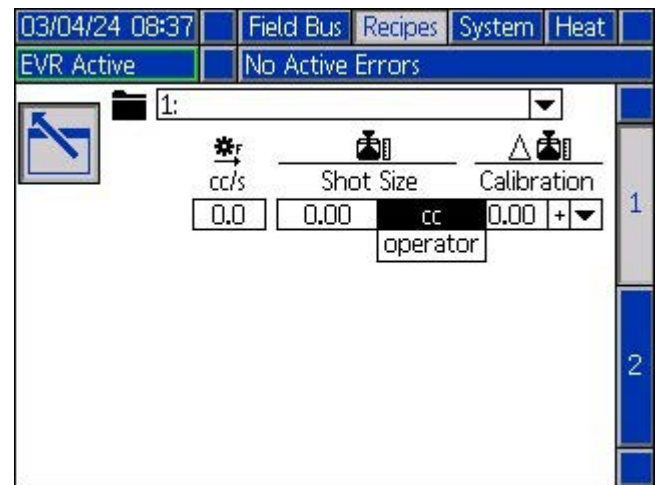
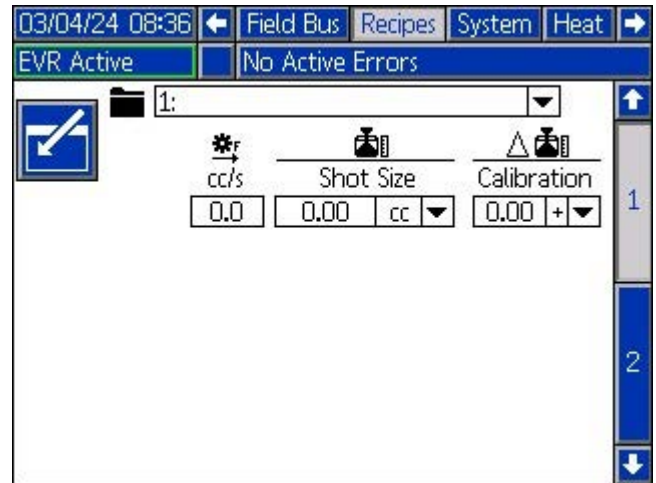



**NOTE:** If the user selects operator mode for the shot size, the EVR will only dispense at the desired flow rate when an external trigger source or foot switch is active, or the ADM triggers a dispense.

If the user selects volume (cc) for the shot size, the EVR will start the dispense when an external trigger or foot switch is pulsed, or the ADM triggers a dispense.



To trigger a dispense through the ADM, see **Home Run Screen**, page 36.

## Recipe Definition Screen 2

This screen allows the user to copy , delete , and name  selected recipes. Use the arrow keys to select a recipe from the list. The recipe selected will be highlighted in green, as shown below.

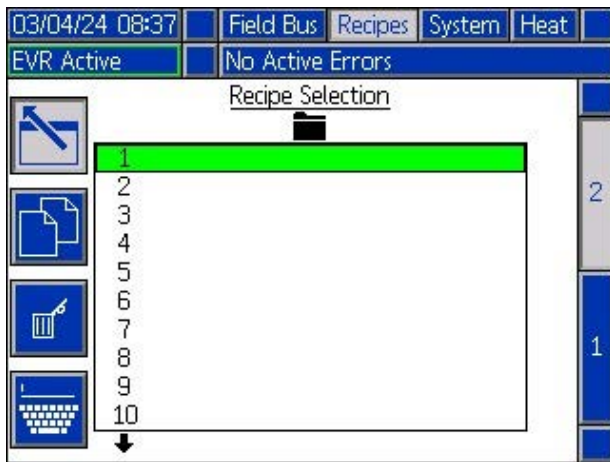



**NOTE:** The recipe selected in this screen will also be shown on Recipe Definition Screen 1, where it can be edited. See **Recipe Definition Screen 1** on page 44.

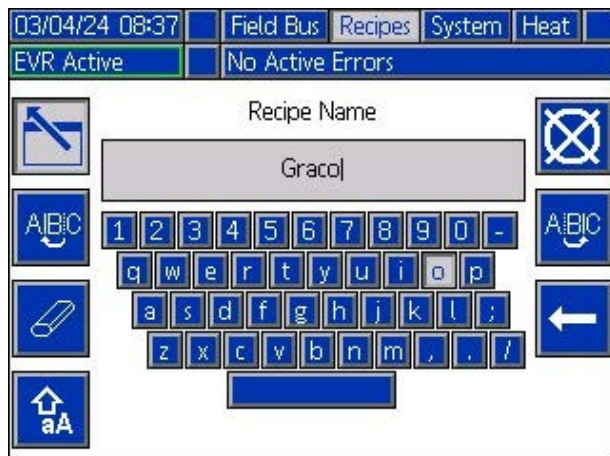



To name a recipe, press the  icon when the desired recipe is selected. A new screen, shown below, will appear and allow the user to edit the name of the selected recipe. Use the arrow keys to select the desired letter and press  to accept the letter. Once finished, press the  icon to store the new name.



## System Setup Screens

On the Index screen, press the  icon to navigate to the recipe definition screen. Use the  arrow on the ADM directional keypad (AH) to navigate to the recipes chapter, then use the  and  arrows to scroll through the screens.

To edit a screen, press the  icon. When finished editing, press the  icon to save any changes.

### System Setup Screen 1

This screen allows the user to change the general information about the system setup. System parameters included on this screen are:

**Valve Type:** the valve type can be set to TC or MD2 depending on which valve is installed on the system.

**NOTE:** If a Voltex valve is connected, the system will automatically display Voltex as the only option.

**NOTE:** If the valve type selected is MD2, the base purge feature is disabled. The MD2 valve design prevents individual opening of the two components.

**Rate Units:** The rate units can be set to minute, second, or hour.

**Pressure Units:** The pressure units can be set to either psi or bar.

**Size:** The user can enter the size of the A and B pumps on the unit here.

**Ratio Direction:** The user can define which pump is set to 1. The options are Red (A):1 or Blue (B):1.

**Ratio:** The user can enter a desired ratio that the system will run at. The limits are defined by the software using the pump size and the ratio direction.

**NOTE:** Any time the user changes the pump sizes on the screen, the software will default back to the fixed ratio of the pumps. After the sizes have been changed, the variable ratio can be adjusted up to five times the

fixed ratio. Example: if pump A is 40cc and pump B is 20cc, the variable ratio can vary between 10:1 and 2:1.

**Ratio Offset:** The user can enter a ratio offset, which is intended to calibrate the system and take into account any offset between materials. The limits are defined by the software using the pump sizes and ratio direction.

**Synchronous Changeovers:** When checked, the EVR system will attempt to change over the pumps simultaneously while monitoring the stroke lengths of the pumps. If the pump's stroke length drops below a specified percentage of the stroke, the system will perform an unsynchronized changeover to re-synchronize the changeovers. If unchecked, the EVR system will monitor position of each pump independently and avoid changeovers during the dispense when the EVR system is able.

**NOTES:** Synchronous changeovers will only happen during a recipe dispense. The synchronization will not start working on recipe dispenses until both pumps find their home position. This is defined as a Bottom Changeover. The synchronized changeover should be enabled if there is an issue with the system staying on ratio during a changeover.

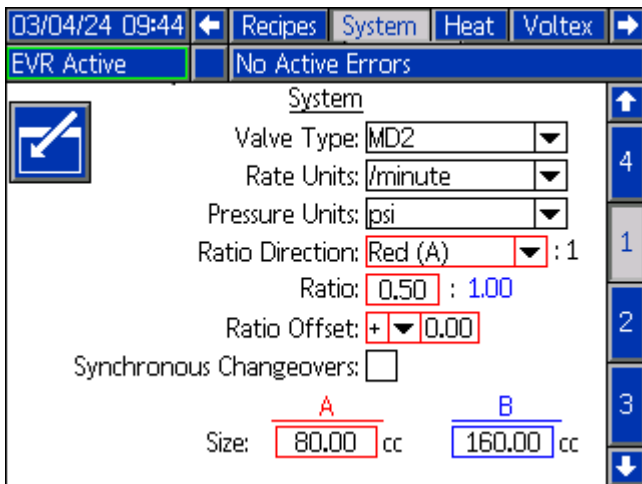

### System Setup Screen 2

This screen allows the user to monitor inlet and outlet pressures of the EVR during a dispense. The user can specify a minimum and maximum allowable values for both A and B pump inlet and outlet pressures. The user can also specify the level of errors for each individual pressure limit. The error options include Disabled, Deviation, and Alarm.

**Disabled:** No pressure monitoring will occur.

**Deviation:** The user will be notified if the pressure goes below the minimum or above the maximum, but further dispensing will be allowed to occur.

**Alarm:** If the pressure goes below the minimum or above the maximum, the current dispense will stop and further dispensing will not be allowed until the alarm is acknowledged.

**Pressure Imbalance Alarm:** When checked, the pressure imbalance alarm will watch the outlet pressure for both A and B pumps. If the pressure difference between the pumps is greater than the pressure defined in the alarm box, an alarm will be triggered.

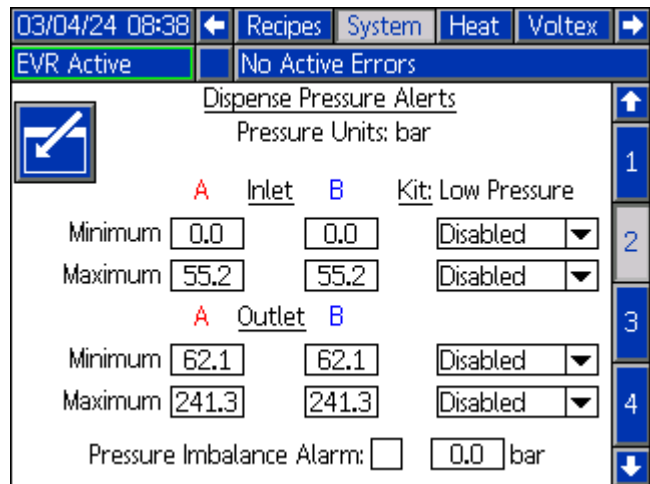

### System Setup Screen 3

This screen allows the user to configure the internal gel timer, purge, and base purge features.

**Gel Timer:** When enabled, the gel timer prevents material from curing in the mixer. The user can set the amount of idle period time the machine can wait between a dispense, along with the amount and flow rate at which the material will dispense. If the system does not dispense again before the idle period time runs out, the gel timer will trigger a dispense.

**Enable:** Turns on/off the gel timer feature.

**Idle Period:** This the amount of time the unit will remain idle before beginning a gel shot dispense.

**Alarm:** Once the idle period is below the alarm value, the ADM will beep to alert the surrounding area that a gel shot is coming soon. At the same time, a "Gel Shot Timer is Alarming" bit will be sent across the fieldbus to

alert the PLC. If the alarm alert is not desired, set this field to 0.

**Amount:** The amount of material the system will automatically dispense after the idle period ends.

**Flow:** The flow rate at which the system will automatically dispense after the idle period ends.

**Purge Rate:** The flow rate at which the system will run



at on ratio when the icon is pressed on the **Home Run Screen**, page 36.

**Base Purge Side:** This variable is used to define which



side the system will base purge when the icon is pressed on the **Home Run Screen**, page 36.



**NOTE:** The icon will have an A or B in the bottom right corner to indicate which side will be base purged.

**Base Purge Rate:** This is the flow rate at which the base purge will operate to maintain the ratio. The rate is automatically calculated, considering the ratio direction and purge rate.

**NOTE:** When the valve type selected on System Setup Screen 1 is MD2, the base purge side and rate are prohibited and will be grayed out. The MD2 valve's design prevents individual opening of the two components.

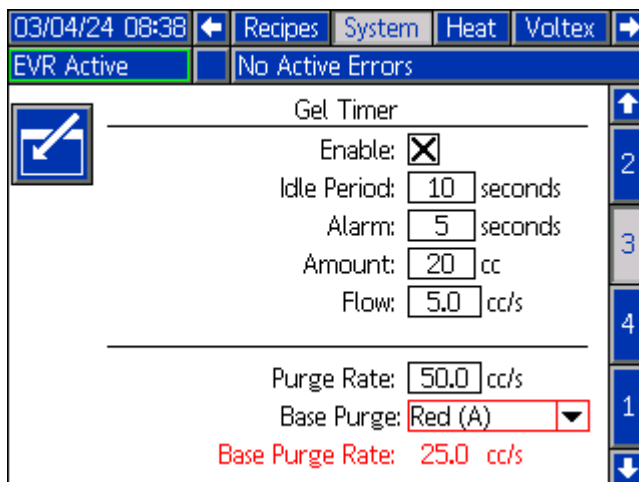

## System Setup Screen 4

This screen allows the user to define the recirculation mode that the EVR will operate on.

**Recirculation Installed:** There are four options available:

- None: The EVR will disable all recirculation features.
- Red: (A): The EVR will only recirculate using pump A.
- Blue (B): The EVR will only recirculate using pump B.
- Both: The EVR can recirculate with pump A and/or pump B.

**Recirculation Valves:** There are two options available:

- Automatic: The recirculation valves are controlled by the EVR system.
- Manual: The recirculation valves are controlled by an external source or a manual process.

**Recirculation Mode:** there are three options available:

- Disabled: The EVR will disable all recirculation features.
- Manual: The EVR will begin recirculating when the



recirculation icon is pressed on the run screen. The EVR will continue until the recirculation



icon is pressed again.

- Timer: The EVR will recirculate for a specified amount of time after a previously set amount of time has expired.

**NOTE:** To start the recirculation timer feature, press the



recirculation icon on the home screen. After the icon is pressed, the EVR will begin recirculating the pumps and count down the recirculation on timer. Once the timer has expired, the EVR will count down the recirculation off timer before repeating the process.

**NOTE:** If the recirculation off timer is counting down when a dispense is requested, or when another feature is enabled, the recirculation timer will be stopped. To place the system back into recirculation, press the



icon.

**Recirculation Pump Method:** This variable is used to define which pump(s) the system will recirculate when

the icon  is pressed.

There are three options available:

- Red (A): The EVR will only recirculate with pump A.
- Blue (B): The EVR will only recirculate with pump B.
- Both: The EVR will recirculate with both pumps.

**NOTE:** If only one side of the pump recirculation is installed, the Recirculation Pump Method will default to that side, and will only run on that pump.

**NOTE:** When Red (A) or Blue (B) is selected as the

Recirculation Pump Method, the  icon will have an A or B in the center to indicate which side will be recirculated. If both are selected as the Recirculation

Pump Method, the  icon will have nothing in the center to indicate that both pumps will be recirculated.

**Recirculation On:** This is the amount of time the system will continue to recirculate if the Recirculation Mode is set to timer.

**Recirculation Off:** This is the amount of time the system will wait before starting the Recirculation On timer when the Recirculation Mode is set to timer.

**Park Using Recirculation Valves:** If this box is checked, the park feature will park the pumps using the recirculation valves instead of the dispense valves.

**Park After Recirculation is Completed:** If this box is checked, along with Park Using Recirculation Valves, the system will automatically start parking the system after recirculation is completed. This can be canceled at any time while parking the pumps by pressing the

 icon on the **Home Run Screen**, page 36.

**NOTE:** The Recirculation On and Recirculation Off time can only be set if the Recirculation Mode is set to timer. Otherwise, the Recirculation On and Recirculation Off fields will be grayed out.



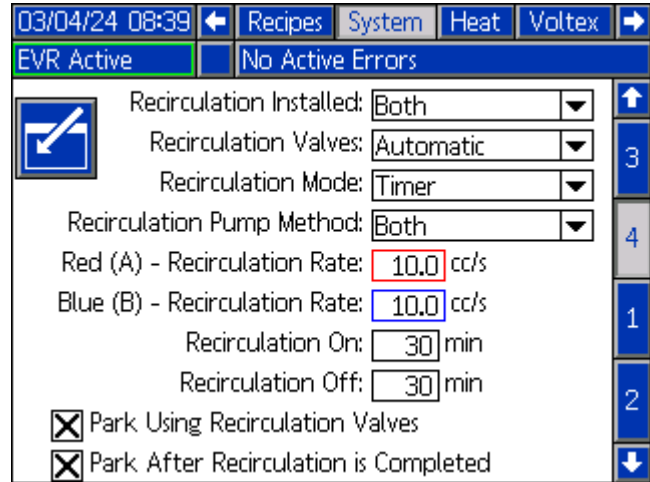

**NOTE:** If disabled is selected for the Recirculation Installed option, all other options on the screen will be grayed out.



**NOTE:** If disabled is selected as the Recirculation Mode option, all other options below Recirculation Mode will be grayed out.





## Heat Setup Screens

On the Index screen, press the  icon to navigate to the Setup screens. Use the  arrow on the ADM directional keypad (AH) to navigate to the Heat chapter, then use the  and  arrows to scroll through the screens.

To edit a screen, press the  icon. When finished editing, press the  icon to save any changes.

**NOTE:** The Heat Setup screens will only be visible when the heat box is connected to the EVR network. If an expansion heat module is connected to the network, Heat Setup screens 3, 5, 7, and 9 will be visible.

**NOTE:** The order of the Heat pages may vary depending on the screens that are displayed.

### Heat Setup Screen 1

This screen allows the user to define the following global heat setup parameters that the EVR system will use:

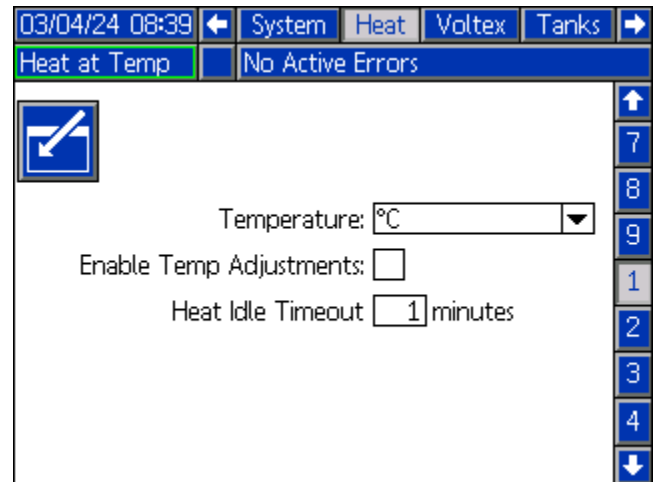

- **Temperature Units:** The temperature can set to either Celsius (°C) or Fahrenheit (°F).
- **Enable Temperature Adjustments:** When this box is checked, the setpoint/setback can be adjusted directly from the **Heat Run Screens**, page 41.
- **Heat Idle Timeout:** The feature allows the user to place the heat into setback after the EVR pumps have not moved for a predetermined amount of time. If the predetermined amount of time passes a second time, the heat will be turned off.

**NOTE:** To disable the Heat Idle Timeout feature, set the value to 0.



## Heat Setup Screens 2 and 3

These screens allow the user to specify the zone type, zone setpoint, zone setback, and enable or disable the zone. Heat Setup Screen 2 relates to the main heat, and Heat Setup Screen 3 relates to the expansion heat. Heat Setup Screen 3 will only be shown if the expansion heat module is connected to the EVR network.

**NOTE:** The  and  icons can be used to request changes to the heat state from the setup screen. When not in edit mode, these icons will appear and will function the same as the icons on the **Heat Run Screens**, page 41.

The first column of Heat Setup screens 2 and 3 corresponds to the connector and zone number. The first number in the column represents the heat connector, and the second number represents the heat zone on the Automatic Multi-Zone (AMZ). For example, 3-5 represents connector 3 and zone 5.

The second column of Heat Setup screens 2 and 3 corresponds to the zone type. The options for the zone type are:

- Hose
- Valve
- Manifold
- PGM
- Flowmeter
- Press Regulator

The third column of Heat Setup screens 2 and 3 corresponds to the heat setpoint temperature, which is the temperature that the controller will operate at when the heat is on.

The fourth column of Heat Setup screens 2 and 3 corresponds to the heat setback temperature, which is the temperature that the controller will operate at when the heat is in setback mode.

The fifth column of Heat Setup screens 2 and 3 corresponds to the zone enable/disable status. When checked, the zone will be controlled to the temperature setpoint or setback, depending on the state of the controller, when the heat is on. If the zone is not checked, the zone will not be used and the zone will be turned off.

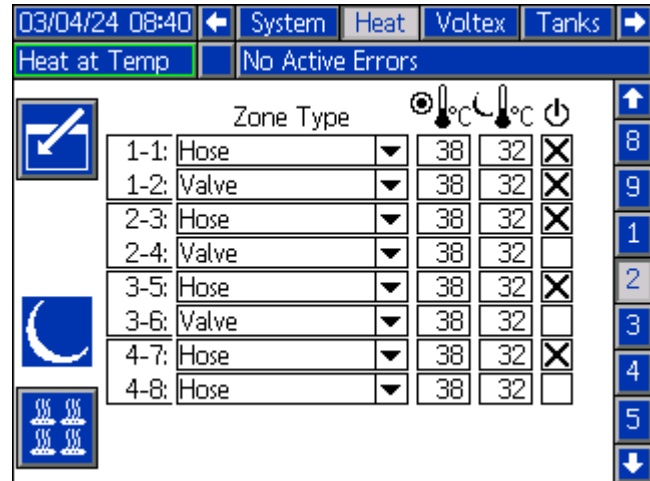

Connector/Zone	Zone Type	Setpoint (°C)	Setback (°C)	Enable
1-1: Hose	Hose	38	32	<input checked="" type="checkbox"/>
1-2: Valve	Valve	38	32	<input checked="" type="checkbox"/>
2-3: Hose	Hose	38	32	<input checked="" type="checkbox"/>
2-4: Valve	Valve	38	32	<input type="checkbox"/>
3-5: Hose	Hose	38	32	<input checked="" type="checkbox"/>
3-6: Valve	Valve	38	32	<input type="checkbox"/>
4-7: Hose	Hose	38	32	<input checked="" type="checkbox"/>
4-8: Hose	Hose	38	32	<input type="checkbox"/>

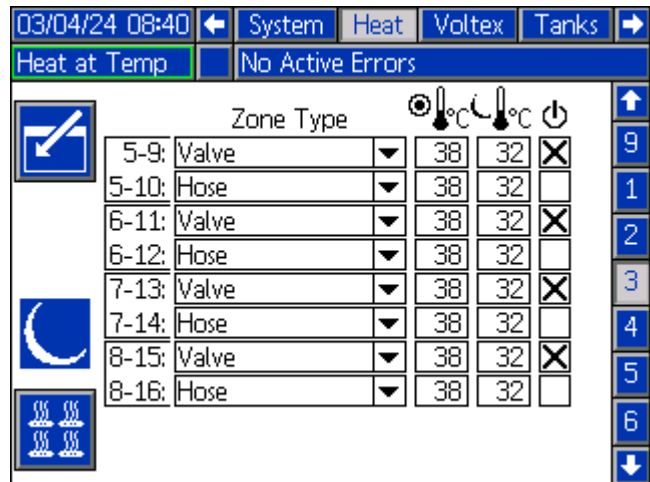



Connector/Zone	Zone Type	Setpoint (°C)	Setback (°C)	Enable
5-9: Valve	Valve	38	32	<input checked="" type="checkbox"/>
5-10: Hose	Hose	38	32	<input type="checkbox"/>
6-11: Valve	Valve	38	32	<input checked="" type="checkbox"/>
6-12: Hose	Hose	38	32	<input type="checkbox"/>
7-13: Valve	Valve	38	32	<input checked="" type="checkbox"/>
7-14: Hose	Hose	38	32	<input type="checkbox"/>
8-15: Valve	Valve	38	32	<input checked="" type="checkbox"/>
8-16: Hose	Hose	38	32	<input type="checkbox"/>

### Heat Setup Screens 4 and 5

These screens allow the user to specify the heatsoak time for each zone. Heat Setup Screen 4 relates to the main heat, and Heat Setup Screen 5 relates to the expansion heat. Heat Setup Screen 5 will only be shown if the expansion heat module is connected to the EVR network.



**NOTE:** The  and  icons can be used to request changes to the heat state from the setup screen. When not in edit mode, these icons will appear and will function the same as the icons on the **Heat Run Screens**, page 41.

The heatsoak time entered in the far right column of Heat Setup Screen 4 and 5 is the additional time required for the heat zone to guarantee uniform heating of the material once the zone reaches the desired set-point temperature. If needed, enter the desired time in minutes.

03/04/24 08:43 System Heat Voltex Tanks

Heat at Temp No Active Errors

Heat Soak

1-1: Hose	0 minutes	1
1-2: Valve	0 minutes	2
2-3: Hose	0 minutes	3
2-4: Valve	0 minutes	4
3-5: Hose	0 minutes	5
3-6: Valve	0 minutes	6
4-7: Hose	0 minutes	7
4-8: Hose	0 minutes	8

03/04/24 08:43 System Heat Voltex Tanks



Heat at Temp No Active Errors

Heat Soak

5-9: Valve	0 minutes	2
5-10: Hose	0 minutes	3
6-11: Valve	0 minutes	4
6-12: Hose	0 minutes	5
7-13: Valve	0 minutes	6
7-14: Hose	0 minutes	7
8-15: Valve	0 minutes	8
8-16: Hose	0 minutes	9

## Heat Setup Screens 6 and 7

These screens allow the user to specify the heat rate for each zone. Heat Setup Screen 6 relates to the main heat, and Heat Setup Screen 7 relates to the expansion heat. Heat Setup Screen 7 will only be shown if the expansion heat module is connected to the EVR network.

**NOTE:** The  and  icons can be used to request changes to the heat state from the setup screen. When not in edit mode, these icons will appear and will function the same as the icons on the **Heat Run Screens**, page 41.

The heat rate time entered in the far right column of Heat Setup Screen 6 and 7 determines the speed at which the zone will heat up. There are three options available:

- Normal
- Slow
- Fast

**NOTE:** The recommended heat rate option is normal. However, if a zone is not reaching the setpoint quickly enough, set the heat rate option to fast for that specific zone. It is important to note that selecting fast as the heat rate option carries a higher risk of overshooting the operating setpoint temperature.

**NOTE:** If the temperature is overshooting the setpoint temperature while the heat rate option is set to normal, change the heat rate option to slow. Note that choosing slow as the heat rate option will extend the time needed for the temperature to reach the operating setpoint.

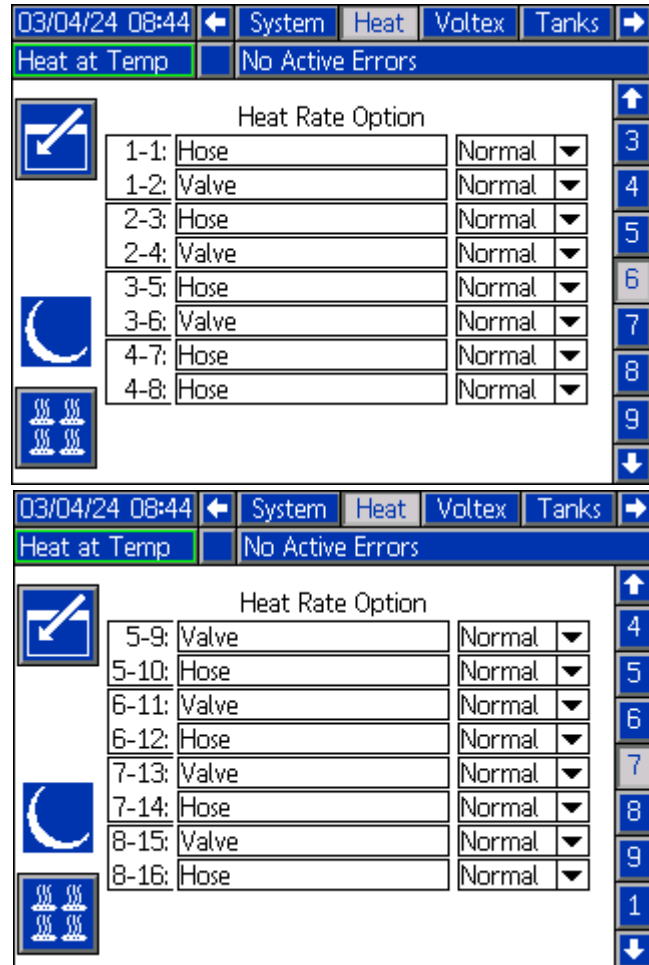

03/04/24 08:44 System Heat VOLTEX Tanks

Heat at Temp No Active Errors

Heat Rate Option

1-1:	Hose	Normal
1-2:	Valve	Normal
2-3:	Hose	Normal
2-4:	Valve	Normal
3-5:	Hose	Normal
3-6:	Valve	Normal
4-7:	Hose	Normal
4-8:	Hose	Normal

03/04/24 08:44 System Heat VOLTEX Tanks

Heat at Temp No Active Errors



Heat Rate Option

5-9:	Valve	Normal
5-10:	Hose	Normal
6-11:	Valve	Normal
6-12:	Hose	Normal
7-13:	Valve	Normal
7-14:	Hose	Normal
8-15:	Valve	Normal
8-16:	Hose	Normal

### Heat Setup Screens 8 and 9

These screens allow the user to specify the heat error bounds for each zone. Heat Setup Screen 8 relates to the main heat, and Heat Setup Screen 9 relates to the expansion heat. Heat Setup Screen 9 will only be shown if the expansion heat module is connected to the EVR network.



**NOTE:** The  and  icons can be used to request changes to the heat state from the setup screen. When not in edit mode, these icons will appear and will function the same as the icons on the **Heat Run Screens**, page 41.

Each column in Heat Setup screens 8 and 9 specifies the allowable temperature difference in degrees from a zone operating temperature before triggering an error.

The red bell icon indicates an alarm, and the white bell icon indicates an advisory. The plus symbol (+) indicates a high level error, and the minus symbol (-) indicates a low level error.

**NOTE:** The default values are 15°C for an advisory, and 25°C for an alarm, but different temperature values can be entered for each zone.

For example: If the zone temperature is set to 50°C, and the user sets +15°C for a high advisory and +25°C for a high alarm, the advisory will occur when the temperature reaches 65°C (50°C + 15°C), and an alarm will occur when the temperature reaches 75°C (50°C + 25°C). The same applies to the low alarm and low advisory settings. Using the same example with a zone temperature of 50°C with a low advisory of -15°C and a low alarm of -25°C, an advisory will occur when the temperature reaches 35°C (50°C - 15°C), and an alarm will occur when the temperature reaches 25°C (50°C - 25°C).

03/04/24 08:44		System	Heat	Voltex	Tanks
Heat at Temp		No Active Errors			
		Units: °C			
		+	+	-	-
1-1:	Hose	24	16	16	24
1-2:	Valve	24	16	16	24
2-3:	Hose	24	16	16	24
2-4:	Valve	24	16	16	24
3-5:	Hose	24	16	16	24
3-6:	Valve	24	16	16	24
4-7:	Hose	24	16	16	24
4-8:	Hose	24	16	16	24

03/04/24 08:44		System	Heat	Voltex	Tanks
Heat at Temp		No Active Errors			
		Units: °C			
		+	+	-	-
5-9:	Valve	24	16	16	24
5-10:	Hose	24	16	16	24
6-11:	Valve	24	16	16	24
6-12:	Hose	24	16	16	24
7-13:	Valve	24	16	16	24
7-14:	Hose	24	16	16	24
8-15:	Valve	24	16	16	24
8-16:	Hose	24	16	16	24

## Heat Globalize Button

When in edit mode on the Heat Setup Screens, the glo-

balize icon  will be shown in the bottom left-hand corner of the screen if a setpoint, setback, heatsoak, heat rate, or heat error bound field is highlighted.

Press the  icon to apply the global setting to all heat zones for the specified field. Upon pressing the





 icon, a confirmation pop-up window will appear to confirm the intention to apply the global setting.

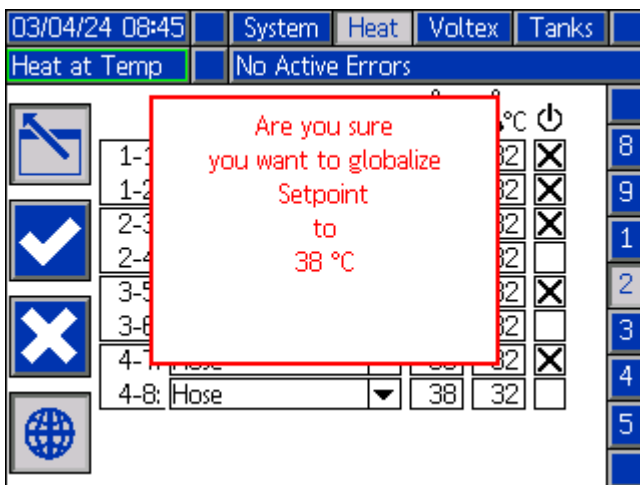

Press the  icon to globalize the field, or press the

 icon to cancel the globalization.



## Voltex Setup Screens

On the Index screen, press the  icon to navigate to the Setup screens. Use the  arrow on the ADM directional keypad (AH) to navigate to the Voltex chapter, then use the  and  arrows to scroll through the screens.

To edit a screen, press the  icon. When finished editing, press the  icon to save any changes.

**NOTE:** The Voltex Setup Screens are only visible if the Voltex controller is connected to the EVR network.

### Voltex Setup Screen 1

**Air Nucleation:** This enables the air nucleation feature, which cycles the air nucleation valve while dispensing to dose air into the mixed material.

**Delay Time:** The amount of time before the air nucleation valve toggles between the on time and off time.

**On Time:** The amount of time the air nucleation valve stays on before toggling off.

**Off Time:** The amount of time the air nucleation valve stays off before toggling back on.

**Motor Speed:** The RPM's that the motor will run at.

**Motor Ramp Up Time:** This changes the amount of time in milliseconds the motor takes to get to the RPM setpoint.

**NOTE:** 100ms is the fastest acceleration, and 9000ms is the slowest acceleration. The goal is to try and prevent breaking mixers with a slower acceleration. Example: 500ms = half a second to get to the RPM setpoint of 4400RPM.

**EVR Dispense Wait:** This will cause the EVR to wait until the Voltex motor is up to speed before dispensing.

**Pressure Calibration:**

1. Relieve pressure in the system using valve depressurization. See **Pressure Relief Procedure** on page 17.





2. Press the edit mode  icon.

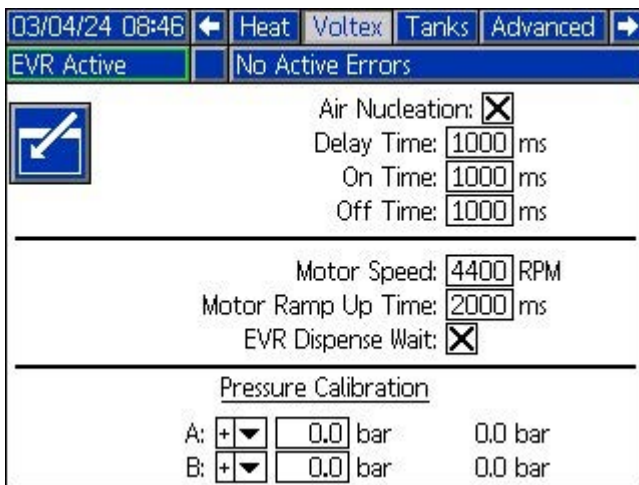

3. Press the  icon to automatically reset the offsets to zero. The values can also be manually adjusted. Choose either positive or negative offset from the drop-down menus, as appropriate for the calibration.

4. Press the  icon to save changes and exit edit mode.



**Tank Stand Setup Screens**

On the Index screen, press the  icon to navigate to the Setup screens. Use the  arrow on the ADM directional keypad (AH) to navigate to the Tanks chapter, then use the  and  arrows to scroll through the screens.

To edit a screen, press the  icon. When finished editing, press the  icon to save any changes.

**NOTE:** The Tank Stand Setup Screens are only visible when either the red tank or blue tank is connected to the EVR network.

**Tank Stand Setup Screen 1**

This screen allows the user to define the operating parameters for off-board, integrated tanks. For information on installing level sensors, refer to the Stainless Steel Tank Stands Instructions-Parts manual. See **Related Manuals** on page 3.

**Level Sensors Installed:** The check boxes shown within the tank image correspond to the installed level sensors. A maximum of three level sensors can be installed, including a low, middle, and high level sensor. Check the box for each installed level sensor for the specified tank. The full level will depend on the sensor configuration.

**NOTE:** If the refill setting is selected as anything other than disabled, at least two level sensors must be installed and the corresponding boxes must be checked on the Tank Setup screen. If all three level sensors are installed, the system will automatically engage the Auto Top-Off feature.

**Refill Settings:** The user can select from the following refill settings:

- Disabled
- Monitor Only
- Manual Fill
- Auto Top-Off

**Disabled:**

- The tank operation is disabled.

**Monitor:**

- The top sensor generates a high level deviation and the bottom sensor generates a low level deviation.
- Refill is not supported, and no button is provided on the **Home Run Screen**, page 36, to initiate refill.
- Errors will clear when the corresponding condition clears.

**Manual:**

- The top sensor generates a high level deviation and the bottom sensor generates a low level deviation.
- An icon is shown on the **Home Run Screen**, page 36, to initiate a manual refill operation at any time.
- Manual refill will continue until either the full level sensor detects material, the user aborts the refill using the refill button on the **Home Run Screen**, page 36, or the refill time-out expires.
- The low level deviation will clear when the condition clears.

**Auto Top-Off:**



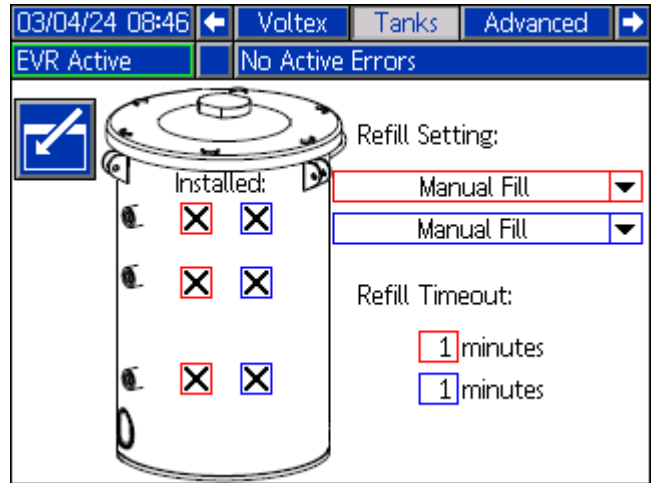

- The top sensor generates a high level deviation and the bottom sensor generates a low level deviation.
- When the full level sensor does not detect material, automatic refill will begin and continue until either the high level sensor detects material or until the refill time-out expires.
- An icon is shown on the **Home Run Screen**, page 36, to initiate an automatic refill operation at any time.
- The refill icon on the **Home Run Screen**, page 36, can also be used to abort a refill operation.
- The low level deviation will clear when the condition clears.
- If the refill is stopped due to an abort or an error, press the refill icon on the **Home Run Screen**, page 36, to resume the Auto Top-Off process.



**Refill Timeout:** The refill timeout setting helps protect against over filling the tank when there is a sensor failure. The value entered is the time the tank has to fill up before timing out. When an automatic refill begins, the time-out counter will begin to count down. If the timer expires before the full level sensor detects material, the refill will abort and an error will be displayed.





## Advanced Setup Screens

On the Index screen, press the  icon to navigate to the Advanced screens. Use the  arrow on the ADM directional keypad (AH) to navigate to the Advanced chapter, then use the  and  arrows to scroll through the screens.

To edit a screen, press the  icon. When finished editing, press the  icon to save any changes.

### Advanced Screen 1

This screen allows the user to change the language, date, and time shown on the ADM. The user can also set up a password and change the screen saver here.

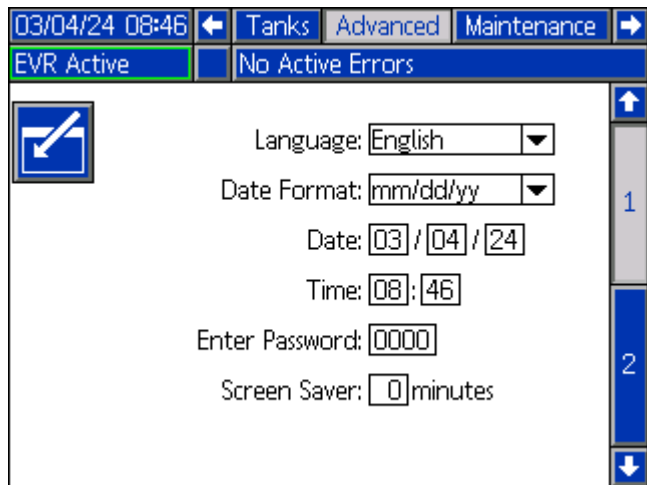





### Advanced Screen 2

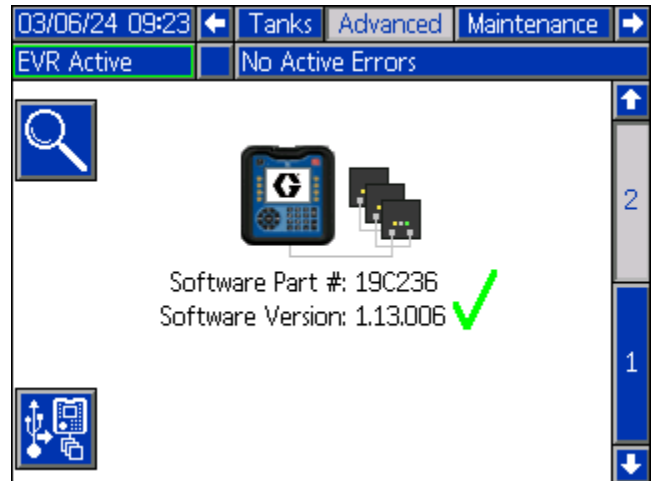

This screen allows the user to view and upgrade software installed on the system. See **Software Update** on page 67 for details on how to upgrade software.

Click the  icon to open a new screen that shows what software is currently installed on the EVR network.



## Maintenance Setup Screens





On the Index screen, press the  icon to navigate to the Maintenance screens. Use the  arrow on the ADM directional keypad (AH) to navigate to the Maintenance chapter, then use the  and  arrows to scroll through the screens.

To edit a screen, press the  icon. When finished editing, press the  icon to save any changes.





### Maintenance Screen 1

This screen keeps track of the cycles of the A and B pump, both current and lifetime, as well as the number of times the dispense valve has opened and closed. The user can also jog the pumps from the maintenance screen.

Once in edit mode  the user can:

- Clear the current cycles for the pumps or the dispense valve by highlighting the desired pump (A or B) or dispense valve, then pressing the  icon.
- Press and hold the arrows at the bottom of the screen to jog the pumps forward  or backward .
- Press the calibrate icon for the desired pump ( for pump A,  for pump B) to calibrate either driver.



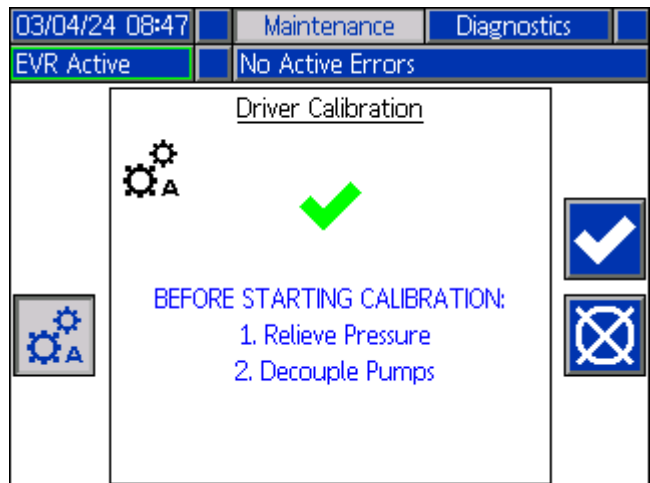
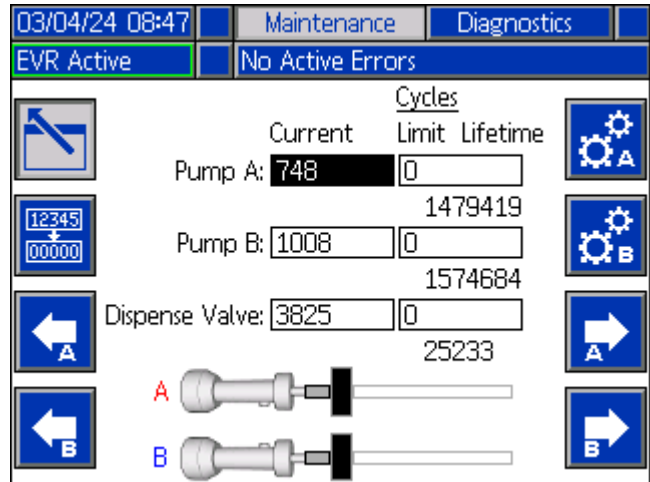

**NOTE:** The  and  icons should only be pressed when the appropriate motor board is replaced, or when error W5N\_ is active.

**NOTE:** The letter shown on the , , , and  icons correspond to the driver that will receive the command.

This screen also allows the user to generate an excessive pump or dispense valve cycles advisory, if the corresponding pump or valve cycles exceeds the number entered in the second column limit field. If a non-zero number is entered in that field, and the corresponding pump or valve cycles exceeds that value, the EVR will generate and log an advisory informing the user of the condition. To remove the advisory, either reset the current counter, increase the limit value, or enter zero for the limit value.



## Diagnostics Setup Screens

On the Index screen, press the  icon to navigate to the Diagnostics screens. Use the  arrow on the ADM directional keypad (AH) to navigate to the Diagnostics chapter, then use the  and  arrows to scroll through the screens.

### Diagnostics Setup Screen 1

This screen allows the user to view the following diagnostics for each driver:

- The line voltage of the incoming AC power.
- The motor temperature.
- The percentage of torque the motor is using
- The position of the pump.
- The direction of the pump.
- The active outlet pressure.
- The active inlet pressure.

**NOTE:** The pump direction diagnostics are represented by either a red or green arrow. A green arrow pointing up means the rod is moving towards the driver housing, and a green arrow pointing down means the rod is moving towards the pumps. A red arrow pointing up signifies a top changeover, and a red arrow pointing down signifies a bottom changeover.

The corresponding status bits illuminate green when each of the following bits is true:

- System Ready
- Unit is B
- Local unit Dispensing
- Pair Unit Dispensing

Diagnostics		A	B	Units
Line Voltage:	209.15	210.28	V	
Motor Temperature:	24	23	°C	
Motor Torque:	0	0	%	
Pump Position:	0.023	0.028	in	
Pump Direction:	↑	↑		
Outlet Pressure:	4.0	1.3	bar	
Inlet Pressure:	1.1	0.9	bar	
System Ready:	●	●		
Unit is B:	●	●		
Local Unit Dispensing:	●	●		
Paired Unit Dispensing:	●	●		

### Diagnostics Setup Screen 2

This screen displays the current output state of the valves installed on the system, depending on the modules that are connected to the EVR network. As a result, the information displayed on this screen may vary slightly.

**NOTE:** A green light means that the valve is open, and the output is on.

Valve Diagnostics		Output State
Dispense Valve A:	●	
Dispense Valve B:	●	
Recirculation Valve A:	●	
Recirculation Valve B:	●	
Air Nucleation:	●	







### Diagnostics Setup Screens 3 and 4

These screens will display heat information diagnostics.

Diagnostics Setup Screen 3 relates to the main heat, and will only be shown when a heat box is connected to the EVR network. Diagnostics Setup Screen 4 relates to the expansion heat, and will be shown when a heat box and an expansion heat module is connected to the EVR network

**NOTE:** If a zone is grayed out, it means that zone is not installed. See the **Heat Setup Screens**, page 49, for instructions on installing the zones.

The first column contains the current zone type heat symbol that defines the zone. There are six different zone type heat symbols:

Zone Type Heat Symbols	
	Hose
	Valve
	Manifold
	PGM
	Flowmeter
	Pressure Regulator

The numbers inside the circle in the first column correspond to the connector and zone. The fill color of the circle corresponds to the current heat state of the zone. There are six different color indicators:

Color	Description
Green	Zone is at temperature
Yellow	Zone is in setback
Yellow to Green	Zone is warming up or is heatsoaking
Green to Red	Zone has a deviation/advisory
Red	Zone has an alarm
White	Zone is turned off

The number in the second column corresponds to the zone setpoint. Depending on the state of the zone, either the setpoint or setback temperature that the controller is actively heating to will be displayed. See **Heat Setup Screen 1**, page 49, for instructions on how to change the temperature units.

The number in the third column corresponds to the zone actual temperature. See **Heat Setup Screen 1**, page 49, for instructions on how to change the temperature units.



The number in the fourth column corresponds to the actual current, in amps (A), that the zone is using.

The number in the fifth column corresponds to the actual pulse width modulation (PWM) that the zone is currently operating at. PWM, or duty cycle, is defined as the amount of time the controller provides current to the heat element over a specific period. The PWM is measured in percentage (%).

The number in the sixth column corresponds to the heatsoak countdown timer, which displays the remaining time that the zone will be in heatsoak. The time is shown in hours : minutes : seconds.

On the right side of the screen, the following information is displayed:

- **Line Voltage** corresponds to the current voltage, in volts (V), measured by the AMZ.
- **Heat Idle** corresponds to the amount of time remaining before the system automatically changes the heat state. The time is shown in hours : minutes : seconds. See **Heat Setup Screen 1**, page 49, for more information on the heat idle timer.

-  icon represents the transformer temperature. See **Heat Setup Screen 1**, page 49, for instructions on how to change the temperature units.
-  icon represents the transformer fan. When this icon is green, the fan is turned on and is running.

**NOTE:** Only the line voltage is displayed on the right side of the expansion heat screen, Diagnostics screen 4. The other options are only shown on the main heat screen, Diagnostics screen 3.

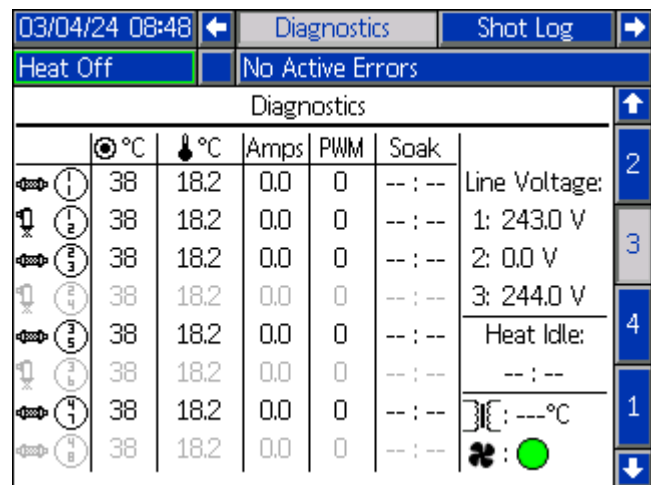



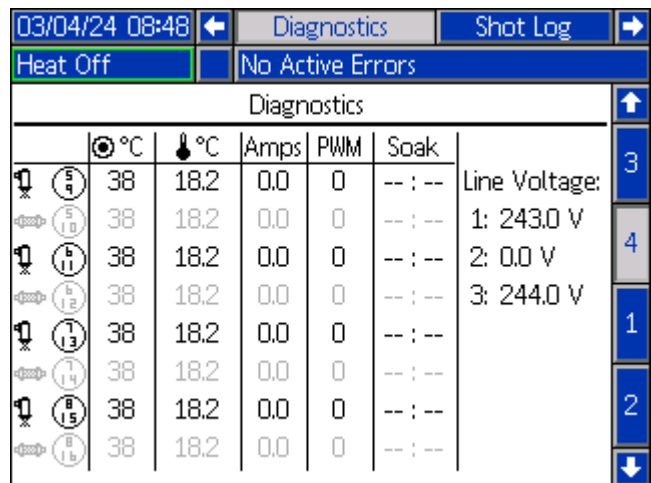





Zone	Setpoint (°C)	Actual (°C)	Amps	PWM	Soak	Line Voltage
1	38	18.2	0.0	0	-- : --	Line Voltage: 1: 243.0 V 2: 0.0 V 3: 244.0 V Heat Idle: -- : -- Transformer Temp: 18.2°C Transformer Fan: 
2	38	18.2	0.0	0	-- : --	
3	38	18.2	0.0	0	-- : --	
4	38	18.2	0.0	0	-- : --	
5	38	18.2	0.0	0	-- : --	
6	38	18.2	0.0	0	-- : --	
7	38	18.2	0.0	0	-- : --	
8	38	18.2	0.0	0	-- : --	







Zone	Setpoint (°C)	Actual (°C)	Amps	PWM	Soak	Line Voltage
9	38	18.2	0.0	0	-- : --	Line Voltage: 1: 243.0 V 2: 0.0 V 3: 244.0 V
10	38	18.2	0.0	0	-- : --	
11	38	18.2	0.0	0	-- : --	
12	38	18.2	0.0	0	-- : --	
13	38	18.2	0.0	0	-- : --	
14	38	18.2	0.0	0	-- : --	
15	38	18.2	0.0	0	-- : --	
16	38	18.2	0.0	0	-- : --	

## Shot Log Setup Screens





On the Index screen, press the  icon to navigate to the Shot Log screens. Use the  arrow on the ADM directional keypad (AH) to navigate to the Shot Log chapter, then use the  and  arrows to scroll through the screens.

The Shot Log screens display a list of all completed shots. Each shot entry includes a date and time stamp, the recipe selected ( # ), the amount dispensed (  ), the number of dispenses summed up in the entry (  ), the ratio (A:B), and the ratio offset (  ).

**NOTE:** If a new dispense is initiated before 0.25 seconds have passed since the completion of the previous dispense, the shot log will assume a stitching scenario. The system will combine those dispenses into a single entry in the shot log. Additionally, if the shot log is actively recording an entry and another dispense is triggered, the system will automatically combine those dispenses into a single entry until the shot log is ready to record. These scenarios are the only instances where more than one dispense could be recorded under a single entry in the shot log. If the time between shots exceeds 0.25 seconds, the dispense will record each dispense individually.

Date	Time	 #			A:B	
03/01/24	14:18	1	141.29cc	47	1.00:1.00	+0.00
03/01/24	14:18	1	151.58cc	51	1.00:1.00	+0.00
03/01/24	14:18	1	146.21cc	49	1.00:1.00	+0.00
03/01/24	14:18	1	155.21cc	52	1.00:1.00	+0.00
03/01/24	14:17	1	150.86cc	51	1.00:1.00	+0.00
03/01/24	14:15	1	146.96cc	49	1.00:1.00	+0.00
03/01/24	14:15	1	151.16cc	51	1.00:1.00	+0.00
03/01/24	14:15	1	149.36cc	50	1.00:1.00	+0.00
03/01/24	14:15	1	150.62cc	50	1.00:1.00	+0.00
03/01/24	14:15	1	150.62cc	50	1.00:1.00	+0.00





## Errors Setup Screens

On the Index screen, press the  icon to navigate to the Errors/Events screens. Use the  arrow on the ADM directional keypad (AH) to navigate to the Errors chapter, then use the  and  arrows to scroll through the screens.

The Error Setup screens display a list of system errors, each accompanied by a description, error code, and a date and time stamp. The most recent error will be displayed first.

Date	Time	Code	Description
03/04/24	08:49		No Active Errors
03/04/24	08:46	L2TA-D	Low Material Level A
03/04/24	08:46	L2TA-D	Low Material Level A
03/04/24	08:33	T6TX-D	Temp Sensor Error Transform
03/04/24	08:33	EAUX-V	USB Activity In Process
03/04/24	08:29	WVCX-D	Motor Fault
03/04/24	08:26	V6H1-A	Wiring Error DO
03/04/24	08:26	CAVX-V	Comm. Error Voltex
03/04/24	08:26	CAK1-V	Comm. Error Auto Multi-Zone
03/04/24	08:24	V6H1-A	Wiring Error DO
03/04/24	08:24	CAVX-V	Comm. Error Voltex





## Events Setup Screens

On the Index screen, press the  icon to navigate to the Errors/Events screens. Use the  arrow on the ADM directional keypad (AH) to navigate to the Events chapter, then use the  and  arrows to scroll through the screens.

The Event Setup screens display a list of system events, each accompanied by a description, error code, and a date and time stamp. The most recent event will be displayed first.

03/04/24 08:50				←	Errors	Events	Integration	→
EVR Active		No Active Errors						
Date	Time	Code	Description					
03/04/24	08:37	EBHX-R	Heat Off	7				
03/04/24	08:36	EDSX-R	Heat in Setback	8				
03/04/24	08:35	EDTX-R	Heat at Temperature	9				
03/04/24	08:35	EAWX-R	Heat is Warming Up	1				
03/04/24	08:35	EBHX-R	Heat Off	2				
03/04/24	08:34	EDTX-R	Heat at Temperature	3				
03/04/24	08:34	EAWX-R	Heat is Warming Up	4				
03/04/24	08:33	EBHX-R	Heat Off					
03/04/24	08:33	ELOX-R	System Power On					
03/04/24	08:33	EMDX-R	System Power Off					





## Integration Setup Screen

On the Index screen, press the  icon to navigate to the Integration Setup screen. Use the  arrow on the ADM directional keypad (AH) to navigate to the Integration chapter, then use the  and  arrows to scroll through the screens.





**Discrete Automation:** This screen displays when the system is sending discrete automation inputs and receiving discrete automation outputs. To activate discrete automation outputs, check the corresponding box for the system to monitor that signal. If a box is left unchecked, the EVR will disregard that discrete automation output. For detailed explanations of each integration pin, see **I/O Integration** on page 68.

**Disable Gateway Errors:** When there is no CGM installed on the system, the Disable Gateway Errors box can be checked. When checked, the system will not monitor for the “CGM module not present” error.

**Disable Trigger Debounce:** Discrete automation output signals enter the system and undergo a 50 ms debounce process. The output signals must remain in the on/off state for at least 50 ms before the system recognizes it as on/off. If the discrete signal is a clean signal, meaning it promptly turns on/off when commanded, the “Disable Trigger Debounce” box can be checked to bypass the debounce logic.

03/04/24 08:50		←	Events	Integration	Field Bus	→	
EVR Active		No Active Errors					
	Disable Gateway Errors: <input type="checkbox"/>						
	Disable Trigger Debounce: <input type="checkbox"/>						
<hr/>							
Discrete Automation							
<hr/>							
Automation Outputs							
	Trigger:	<input checked="" type="checkbox"/>					
	Recipe Select:	<input type="checkbox"/>					1
<hr/>							
Automation Inputs							
	Dispense Valve:						
	System Ready:						
	Error Present:						

## Fieldbus Setup Screens

On the Index screen, press the  icon to navigate to the Integration Setup screen. Use the  arrow on the ADM directional keypad (AH) to navigate to the Fieldbus chapter, then use the  and  arrows to scroll through the screens.

**NOTE:** The Fieldbus Setup screens are only visible when the Communication Gateway Module (CGM) is connected to the EVR network.

Depending on the CGM protocol on the network (DeviceNet, EtherNet/IP, ProfiBus, or ProfiNet), the corresponding screens below will be displayed to establish a connection with the PLC over the specific protocol. Map information will be shown on the screen to display the map currently installed on the CGM.

### DeviceNet Fieldbus Setup Screen 1

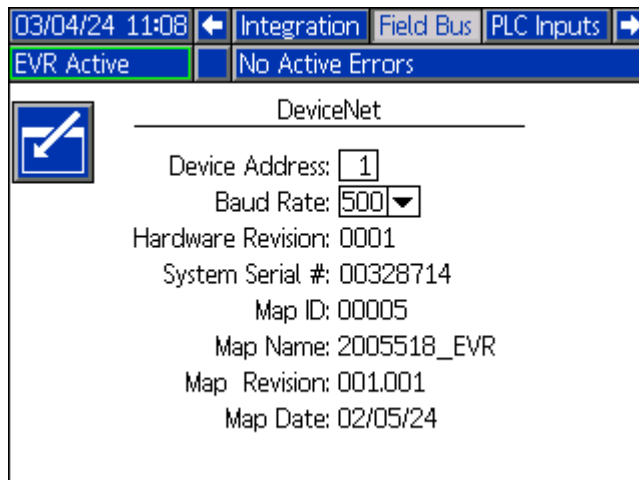

03/04/24 11:08 | Integration | Field Bus | PLC Inputs

EVR Active | No Active Errors

**DeviceNet**

Device Address:

Baud Rate:

Hardware Revision: 0001

System Serial #: 00328714

Map ID: 00005

Map Name: 2005518\_EVR

Map Revision: 001.001

Map Date: 02/05/24

### EtherNet/IP Fieldbus Setup Screen 1

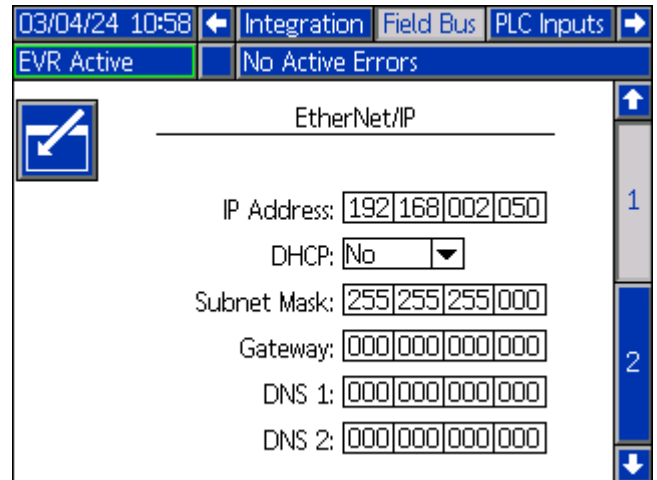

03/04/24 10:58 | Integration | Field Bus | PLC Inputs

EVR Active | No Active Errors

**EtherNet/IP**

IP Address:

DHCP:

Subnet Mask:

Gateway:

DNS 1:

DNS 2:

### EtherNet/IP Fieldbus Setup Screen 2

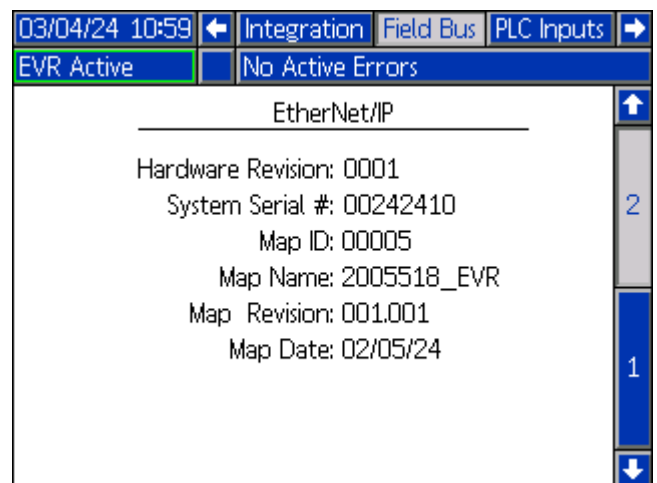

03/04/24 10:59 | Integration | Field Bus | PLC Inputs

EVR Active | No Active Errors

**EtherNet/IP**

Hardware Revision: 0001

System Serial #: 00242410

Map ID: 00005

Map Name: 2005518\_EVR

Map Revision: 001.001

Map Date: 02/05/24

### ProfiBus Fieldbus Setup Screen 1

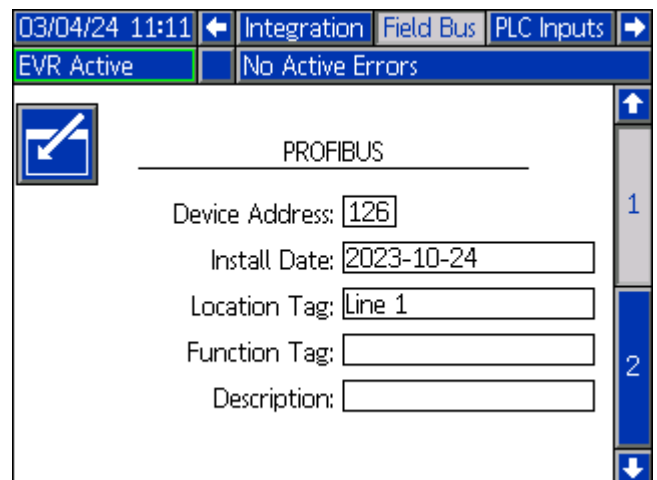

03/04/24 11:11 | Integration | Field Bus | PLC Inputs

EVR Active | No Active Errors

**PROFIBUS**

Device Address:

Install Date:

Location Tag:

Function Tag:

Description:

### ProfiBus Fieldbus Setup Screen 2

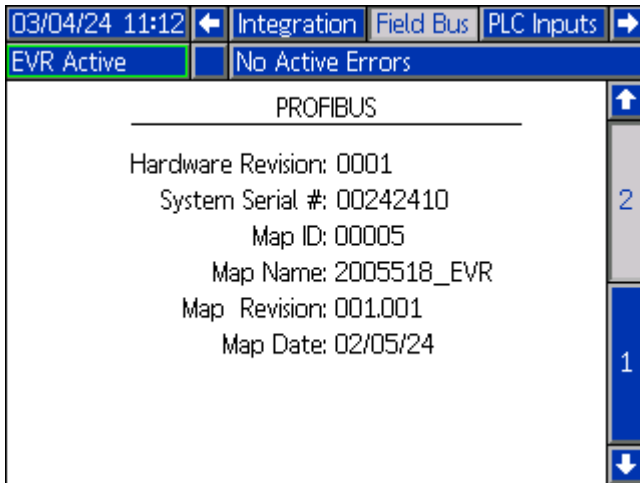



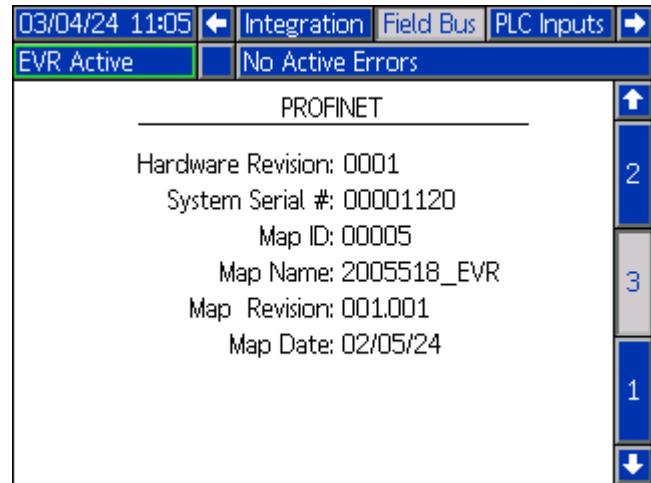

### ProfiNet Fieldbus Setup Screen 3

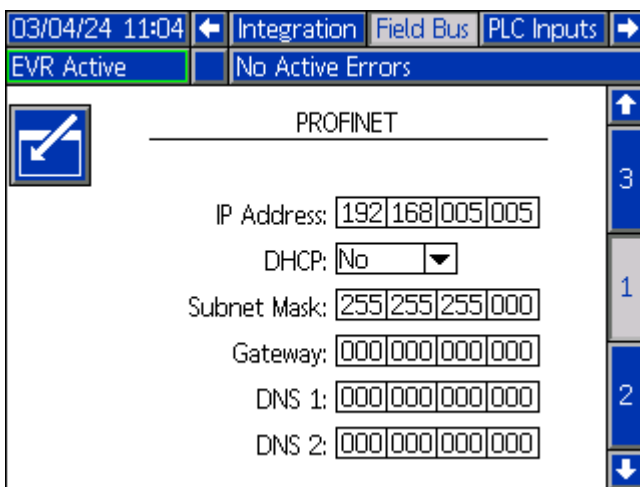

### ProfiNet Fieldbus Setup Screen 1



### PLC Inputs Setup Screens

On the Index screen, press the  icon to navigate to the Integration Setup screen. Use the  arrow on the ADM directional keypad (AH) to navigate to the PLC Inputs chapter, then use the  and  arrows to scroll through the screens.

This screen displays the status of the PLC input signals that can be used to troubleshoot when integrating the EVR.

### PLC Inputs Setup Screen 1

### ProfiNet Fieldbus Setup Screen 2

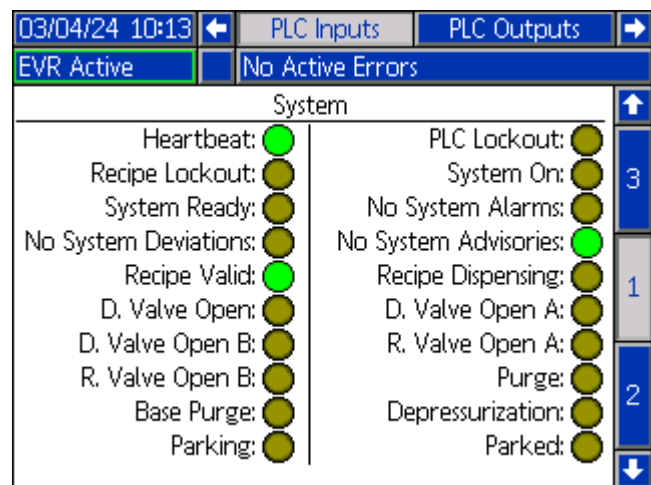
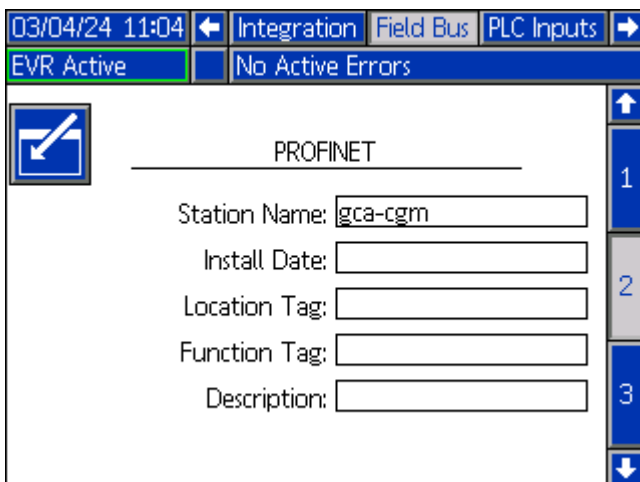



### PLC Inputs Setup Screen 2

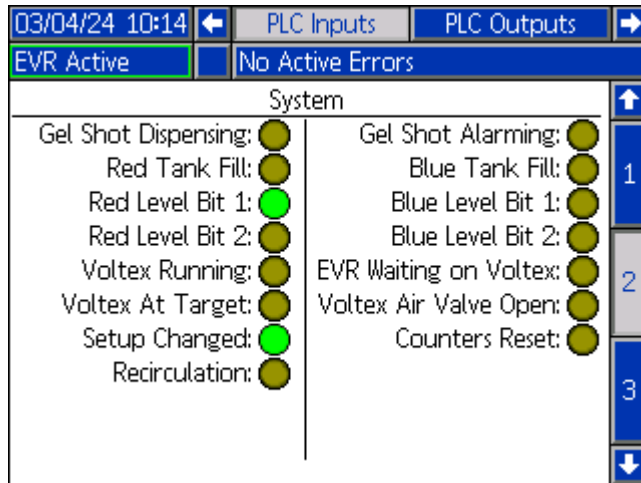

### PLC Inputs Setup Screen 3

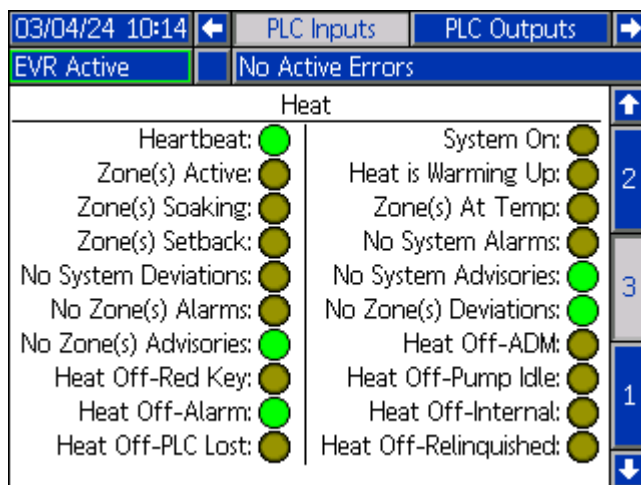

**NOTE:** The PLC Inputs Setup screens will only be displayed under the following conditions:





- A CGM is present on the EVR network.
- The CGM has the corresponding map installed.

The PLC Inputs Setup screen displayed is determined by the map installed on the CGM. The available maps include:

Map Token P/N	Map Name	PLC Input Screen Shown
2006192	EVR Heated Map	1, 2, and 3
2006194	EVR Ambient Map	1 and 2

If the map installed is not in the list above, these screens will not be displayed.

## PLC Outputs Setup Screens

On the Index screen, press the  icon to navigate to the Integration Setup screen. Use the  arrow on the ADM directional keypad (AH) to navigate to the PLC Outputs chapter, then use the  and  arrows to scroll through the screens.

This screen displays the status of the PLC output signals that can be used to troubleshoot when integrating the EVR.

### PLC Outputs Setup Screen 1

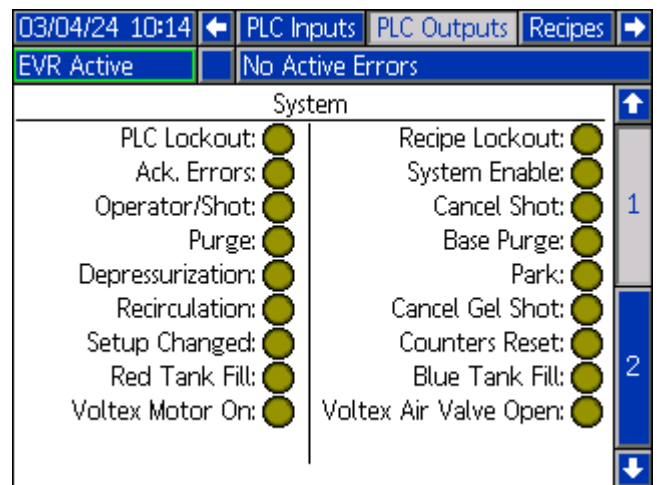

### PLC Outputs Setup Screen 2

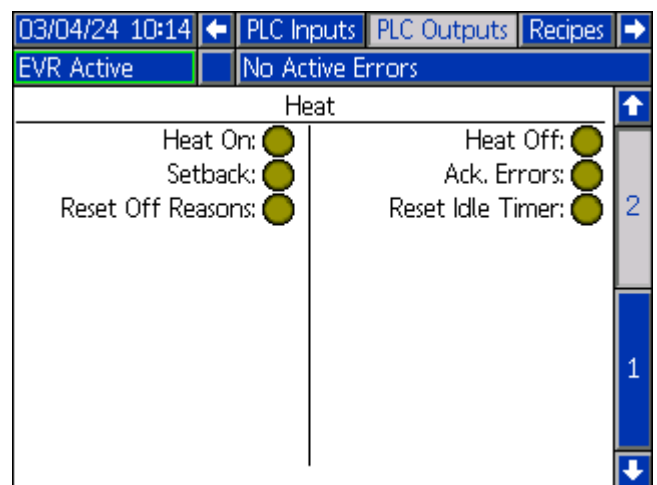

**NOTE:** The PLC Output Setup screens will only be displayed under the following conditions:

- A CGM is present on the EVR network.
- The CGM has the corresponding map installed.

The PLC Outputs Setup screen displayed is determined by the map installed on the CGM. The available maps include:

Map Token P/N	Map Name	PLC Output Screen Shown
2006192	EVR Heated Map	1 and 2
2006194	EVR Ambient Map	1

If the map installed is not in the list above, these screens will not be displayed.

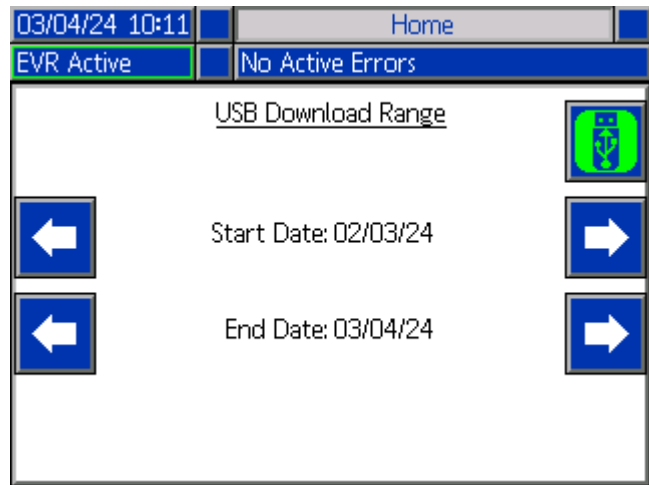

## USB Plug-In Screen

This screen will appear when a USB device is plugged into the ADM.

On this screen, the user can select dates to download data from the ADM to the USB device by pressing the

left  and right  icons on either side of the screen.

After selecting the desired dates, press the download

 icon, which will trigger the download process. Data available for download onto a USB device include shot log data, errors data, and events data. If a heat box is connected to the EVR network, heat data will also be available to download.

Press the cancel  icon to abort the USB download.

# Software Update

**NOTE:** If burning your own software token, see the ADM Token Programming manual. See **Related Manuals** on page 3.

## 19C237 Software Update Procedure

**NOTE:** A token can be found in the ADM token compartment.

When software is updated on the ADM the software is then automatically updated on all connected modules. A status screen is shown while software is updating to indicate progress.

1. Turn Power Disconnect Switch (C) to the OFF position.
2. Remove ADM from bracket.
3. Remove token access panel (BK).

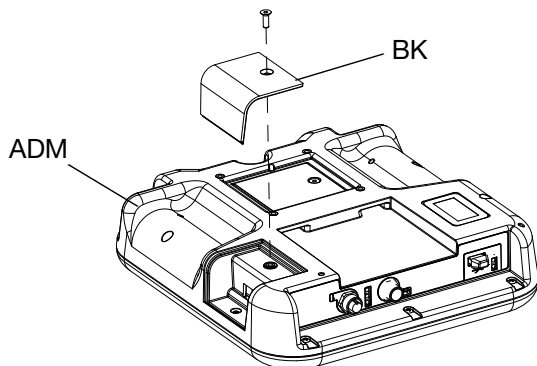

4. Insert and press EVR software upgrade token (TK, part no. 19C237) firmly into slot.

**NOTE:** There is no preferred orientation of token.

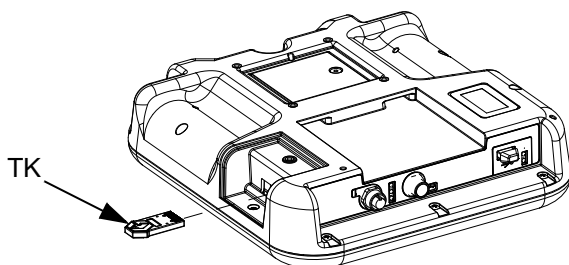

5. Turn the Power Disconnect Switch (C) to the ON position.

NOTICE
A status is shown while software is updating to indicate progress. To prevent corrupting the software load, do not remove token until the status screen disappears.

**NOTE:** When the ADM display turns on, you may see the following screens:

<p><b>First:</b></p> <p><i>Software is checking which modules will take the available updates.</i></p>	
<p><b>Second:</b></p> <p><i>Status of the update with approximate time until completion.</i></p>	
<p><b>Third:</b></p> <p><i>Updates are complete. Icon indicates update success/failure. See the following Icon table.</i></p>	

Icon	Description
	Update successful.
	Update unsuccessful.
	Update complete, no changes necessary.
	Modules were updated or didn't require an update; however, one or more modules need to be updated manually with a token.

6. Remove token (TK).
7. Replace token access panel (BK).
8. Install ADM into bracket.
9. Press to continue to EVR operation screens.

# I/O Integration

Connector	Pin	Input/Output	Description
Valve	1	---	---
	2	24 VDC Digital Output • 24V is ON • 0V is OFF	Valve B
	3	Ground/Return	Ground
	4	24 VDC Digital Output • 24V is ON • 0V is OFF	Valve A
	5	---	---
Trigger	1	24VDC Output	24V for dry contact closure
	2	---	---
	3	Trigger	Trigger a dispense on the EVR
	4	---	---
	5	---	---
Integration	1	Output	System Ready
	2	Output	Alarm Present
	3	Ground/Return	Ground
	4	Input	Recipe Select
	5	Input	Recipe Number Bit 0
	6	Input	Recipe Number Bit 1
	7	Input	Recipe Number Bit 2
	8	Input	Recipe Number Bit 3
Recirculation	1	---	---
	2	24 VDC Digital Output • 24V is ON • 0V is OFF	Recirculation Valve B
	3		Ground
	4	24 VDC Digital Output • 24V is ON • 0V is OFF	Recirculation valve A
	5	---	---
Tip Shutoff	1	---	---
	2	---	---
	3	Ground/Return	Ground
	4	24 VDC Digital Output • 24V is ON • 0V is OFF	Tip Shutoff Valve
	5	---	---

# Communications Gateway Module (CGM)

## Overview

The Communications Gateway Module (CGM) provides a control link between the EVR system and a selected fieldbus. This allows for report monitoring and control by external PLC automation systems.

The following fieldbus options that are supported for the EVR include:

- DeviceNet
- EtherNet/IP
- ProfiBus
- ProfiNet

**NOTE:** The following system network configuration files are available at [help.graco.com](http://help.graco.com).

- **EDS file:** DeviceNet or EtherNet/IP fieldbus networks
- **GSD file:** ProfiBus fieldbus networks
- **GSDML file:** ProfiNet fieldbus networks

## Map Options

The following are maps that can be used to integrate an EVR system with an external PLC automation system:

Map Token Part Number	Map Software Part Number	Map Description
2006192	2005518	EVR Heated Map
2006194	2005522	EVR Ambient Map

**NOTE:** If the EVR has a heat box on the network, and control over the heat is desired from the external PLC automation system, it is recommended to use the EVR heated map.

## EVR and PLC Connection Setup

Verify that the PLC parameters are set up correctly. See the Gateway Map tables below for details.

**NOTE:** If the PLC connection parameters are not set up correctly, the connection between the EVR and PLC will not be made.

EVR Heated Map	
<b>Gateway Map Token: 2006192</b>	
<b>Map Name on ADM: 2005518_EVR</b>	
Comm. Format:	Data - SINT
Input Assembly Instance:	100
Input Instance Size:	184
Output Assembly Instance:	150
Output Instance Size:	72

EVR Heated Map	
<b>Gateway Map Token: 2006194</b>	
<b>Map Name on ADM: 2005522_EVR</b>	
Comm. Format:	Data - SINT
Input Assembly Instance:	100
Input Instance Size:	92
Output Assembly Instance:	150
Output Instance Size:	40

## Available Internal Data

Unless stated otherwise, bytes are stored in each instance in little endian order (byte order with instances: most significant to least significant).

**NOTE:** Automation Outputs can be monitored by the corresponding automation inputs to verify the EVR received the data.

**NOTE:** It is recommended to introduce a 50 ms delay between each automation signal.

**NOTE:** For dispensing a bead, it is recommended to utilize the discrete trigger signal instead of the fieldbus trigger signal. This is due to potential timing issues and delays associated with the fieldbus trigger signal. See **I/O Integration** on page 68 for location hook-up details.



## PLC Automation Inputs

**NOTE:** Print the following tables in color.

**NOTE:** The ambient map is only made up of the EVR signals highlighted in green. The heated map is made up of both the EVR signals highlighted in green, and the heat signals highlighted in yellow.

Key
EVR Signals
Heat Signals

<i>EVR Fieldbus Map 2006192 and 2006194</i>						
Automation Inputs (signal from EVR to PLC)						
Data Type	Byte	Bit	Description	Minimum Value	Maximum Value	Additional Info
DINT	0-3	0-31	Current ADM Date	0	16777215	See <b>Time and Date</b> on page 97 for more information.
DINT	4-7	0-31	Current ADM Time	0	16777215	

<b>EVR Fieldbus Map 2006192 and 2006194</b>						
<b>Automation Inputs (signal from EVR to PLC)</b>						
<b>Data Type</b>	<b>Byte</b>	<b>Bit</b>	<b>Description</b>	<b>Minimum Value</b>	<b>Maximum Value</b>	<b>Additional Info</b>
DINT	8-11	0	Heartbeat To PLC	0	1	---
		1	PLC Lockout is Active	0	1	---
		2	Gateway Recipe Lockout Active	0	1	---
		3	System On	0	1	---
		4	System Ready	0	1	---
		5	No System Level Alarms are Present	0	1	---
		6	No System Level Deviations are Present	0	1	---
		7	No System Level Advisories are Present	0	1	---
		8	Recipe is Valid	0	1	---
		9	Recipe is Dispensing	0	1	---
		10	Dispense Valve is Open	0	1	---
		11	Dispense Valve A is Open	0	1	---
		12	Dispense Valve B is Open	0	1	---
		13	Auto Recirculation Valve A is Open	0	1	---
		14	Auto Recirculation Valve B is Open	0	1	---
		15	System is Purging	0	1	---
		16	System is Base Purging	0	1	---
		17	System is Depressurizing	0	1	---
		18	System is Parking	0	1	---
		19	System is Parked	0	1	---
		20	System is Recirculating	0	1	---
		21	Gel Shot is Dispensing	0	1	---
		22	Gel Shot Countdown Timer is Alarming	0	1	---
		23	Red Tank Stand Is Filling	0	1	---
		24	Red Tank Stand Level  (0 - Unknown, 1 - Low, 2 - Middle, 3 - High)	0	3	---
		25		---		
		26	Blue Tank Stand Is Filling	0	1	---
		27	Blue Tank Stand Level  (0 - Unknown, 1 - Low, 2 - Middle, 3 - High)	0	3	---
		28		---		
		29	Voltex Motor Is Running	0	1	---
		30	EVR Dispense Waiting for Voltex Motor to Reach Speed	0	3	---
31	Voltex Motor is at Target Speed	0	1	---		

<b>EVR Fieldbus Map 2006192 and 2006194</b>							
<b>Automation Inputs (signal from EVR to PLC)</b>							
<b>Data Type</b>	<b>Byte</b>	<b>Bit</b>	<b>Description</b>	<b>Minimum Value</b>	<b>Maximum Value</b>	<b>Additional Info</b>	
DINT	12-15	0	Voltex Air Injection Valve Open	0	1	---	
		1	ADM Setup Value(s) Changed	0	1	---	
		2	ADM Counter Value(s) Reset	0	1	---	
		3	Active Module Alarms Present - Red MCM	0	1	Status bits, used to know what needs to be scanned using the Active Module Errors Look-Up of the map	
		4	Active Module Deviations Present - Red MCM	0	1		
		5	Active Module Advisories Present - Red MCM	0	1		
		6	Active Module Alarms Present - Blue MCM	0	1		
		7	Active Module Deviations Present - Blue MCM	0	1		
		8	Active Module Advisories Present - Blue MCM	0	1		
		9	Active Module Alarms Present - Red Tank Stand	0	1		
		10	Active Module Deviations Present - Red Tank Stand	0	1		
		11	Active Module Advisories Present - Red Tank Stand	0	1		
		12	Active Module Alarms Present - Blue Tank Stand	0	1		
		13	Active Module Deviations Present - Blue Tank Stand	0	1		
		14	Active Module Advisories Present - Blue Tank Stand	0	1		
		15	Active Module Alarms Present - Voltex	0	1		
		16	Active Module Deviations Present - Voltex	0	1		
		17	Active Module Advisories Present - Voltex	0	1		
		18-31	Reserved Bits 18-27	---	---		---
DINT	16-19	0-31	Active Module Errors Look Up - Active Alarms Bitfield	0	4294967295		Will display the errors for the "Active Module Error - Look Up" below
DINT	20-23	0-31	Active Module Errors Look Up - Active Deviations Bitfield	0	4294967295		
DINT	24-27	0-31	Active Module Errors Look Up - Active Advisories Bitfield	0	4294967295		
DINT	28-31	0-7	Active Module Errors - Look Up	1	5	1 = Red MCM 2 = Blue MCM 3 = Red Tank Stand 4 = Blue Tank Stand 5 = Voltex	
		8-15	Current Active Recipe	0	50	---	
		16-31	Combined Pump Flowrate	0.00	200.00	XXX.XX cc/sec	



<b>EVR Fieldbus Map 2006192 and 2006194</b>						
<b>Automation Inputs (signal from EVR to PLC)</b>						
<b>Data Type</b>	<b>Byte</b>	<b>Bit</b>	<b>Description</b>	<b>Minimum Value</b>	<b>Maximum Value</b>	<b>Additional Info</b>
DINT	32-35	0-15	Red Pump Outlet Pressure	0.00	300.00	XXX.XX bar
		16-31	Blue Pump Outlet Pressure	0.00	300.00	XXX.XX bar
DINT	36-39	0-15	Red Pump Inlet Pressure	0.00	300.00	XXX.XX bar
		16-31	Blue Pump Inlet Pressure	0.00	300.00	XXX.XX bar
DINT	40-43	0-15	System - Ratio	1.00	160.00	X.XX : 1.00
		16-31	System - Ratio Offset	-0.50	0.50	-/+ X.XX
DINT	44-47	0-31	Active Recipe - Amount Dispensed	0	21474836.47	XXXX.XX cc
DINT	48-51	0-31	Active Recipe - Shot Size	0	9999.99	XXXX.XX cc
DINT	52-55	0-15	Active Recipe - Flowrate	0	200.00	XXXX.XX cc/sec
		16-31	Active Recipe - Shot Calibration	-99.99	99.99	-/+ XX.XX cc
DINT	56-59	0-7	Active Recipe - Dispense Type	0	1	0=Shot 1=Operator
		16-23	Active Recipe - Shot Remaining Time	0	99999.9	XXXX.X seconds
		24-31	Reserved Bits 24-31	---	---	---
DINT	60-63	0-31	Reserved Bits 0-31	---	---	---
DINT	64-67	0-31	Recipe Look Up - Shot Size	0.00	999.99	XXX.XX cc
DINT	68-71	0-15	Recipe Look Up - Flowrate	0	200.00	XXX.XX cc/sec
		8-31	Recipe Look Up - Calibration Offset	-99.99	99.9	-/+ XX.XX cc
DINT	72-75	0-7	Recipe Look Up - Dispense Type	0	1	0=Shot 1=Operator
		8-15	Recipe Look Up - Recipe Number	0	50	---
		16-31	Reserved Bits 16-31	---	---	---
DINT	76-79	8-15	Gel Time Remaining before Gel Shot	0	9999	XXXX seconds
		16-31	Recirculation Time Remaining $\rho$	0	25200	XXXX seconds
DINT	80-83	0-31	Reserved Bits 0-31	---	---	---
DINT	84-87	0-15	Selected Data Exchange Element	0	32,767	---
DINT	88-91	0-31	Selected Data Exchange Element Value	<b>See Data Exchange</b> on page 87 for Min and Max Values.		---
<b>Transition to Heated Map 2006192</b>						
DINT	92-95	0-15	Heat - Selected Data Exchange Element	0	32,767	---

<i>EVR Fieldbus Map 2006192 and 2006194</i>						
<b>Automation Inputs (signal from EVR to PLC)</b>						
<b>Data Type</b>	<b>Byte</b>	<b>Bit</b>	<b>Description</b>	<b>Minimum Value</b>	<b>Maximum Value</b>	<b>Additional Info</b>
DINT	96-99	0-31	Heat - Selected Data Exchange Element Value	See <b>Data Exchange</b> on page 87 for Min and Max Values.		---
DINT	100-103	0	Reserved Bool 0	0	1	---
		1	Heat - Heartbeat To PLC	0	1	---
		2	Heat - System Active (Power On)	0	1	---
		3	Heat - Zone(s) Active	0	1	---
		4	Heat - Zone(s) Warm	0	1	---
		5	Heat - Zone(s) Heat Soak	0	1	---
		6	Heat - All Zone(s) At Temperature	0	1	---
		7	Heat - All Zone(s) In Setback Mode	0	1	---
		8	Heat - No System Level Alarms Present	0	1	---
		9	Heat - No System Level Deviations Present	0	1	---
		10	Heat - No System Level Advisories Present	0	1	---
		11	Heat - No Zone(s) Alarms are Present	0	1	---
		12	Heat - No Zone(s) Deviations are Present	0	1	---
		13	Heat - No Zone(s) Advisories are Present	0	1	---
		14	New Setpoint Temperatures Accepted	0	1	---
		15	New Setpoint Temperatures Rejected	0	1	---
		16	New Setback Temperatures Accepted	0	1	---
		17	New Setback Temperatures Rejected	0	1	---
		18	New Heatsoak Times Accepted	0	1	---
		19	New Heatsoak Times Rejected	0	1	---
		20	New Zone Installation Request Accepted	0	1	---
		21	New Zone Installation Request Rejected	0	1	---
		22-24	Reserved Bool 20-24	---	---	---
		25	Heat Off Reason - From ADM	0	1	---
		26	Heat Off Reason - ADM Red Key Pressed	0	1	---
		27	Heat Off Reason - Pump Idle Timeout	0	1	---
		28	Heat Off Reason - Alarm Detected	0	1	---
		29	Heat Off Reason - Internal Graco Network Lost	0	1	---
		30	Heat Off Reason - PLC Connection Lost	0	1	---
		31	Heat Off Reason - PLC Relinquished Control	0	1	---

<b>EVR Fieldbus Map 2006192 and 2006194</b>						
<b>Automation Inputs (signal from EVR to PLC)</b>						
<b>Data Type</b>	<b>Byte</b>	<b>Bit</b>	<b>Description</b>	<b>Minimum Value</b>	<b>Maximum Value</b>	<b>Additional Info</b>
DINT	104-107	0	Heat - Zone 1 Installed	0	1	---
		1	Heat - Zone 2 Installed	0	1	---
		2	Heat - Zone 3 Installed	0	1	---
		3	Heat - Zone 4 Installed	0	1	---
		4	Heat - Zone 5 Installed	0	1	---
		5	Heat - Zone 6 Installed	0	1	---
		6	Heat - Zone 7 Installed	0	1	---
		7	Heat - Zone 8 Installed	0	1	---
		8	Heat - Zone 9 Installed	0	1	---
		9	Heat - Zone 10 Installed	0	1	---
		10	Heat - Zone 11 Installed	0	1	---
		11	Heat - Zone 12 Installed	0	1	---
		12	Heat - Zone 13 Installed	0	1	---
		13	Heat - Zone 14 Installed	0	1	---
		14	Heat - Zone 15 Installed	0	1	---
		15	Heat - Zone 16 Installed	0	1	---
		16	Heat - Zone 1 Active	0	1	---
		17	Heat - Zone 2 Active	0	1	---
		18	Heat - Zone 3 Active	0	1	---
		19	Heat - Zone 4 Active	0	1	---
		20	Heat - Zone 5 Active	0	1	---
		21	Heat - Zone 6 Active	0	1	---
		22	Heat - Zone 7 Active	0	1	---
		23	Heat - Zone 8 Active	0	1	---
		24	Heat - Zone 9 Active	0	1	---
		25	Heat - Zone 10 Active	0	1	---
		26	Heat - Zone 11 Active	0	1	---
		27	Heat - Zone 12 Active	0	1	---
		28	Heat - Zone 13 Active	0	1	---
		29	Heat - Zone 14 Active	0	1	---
		30	Heat - Zone 15 Active	0	1	---
		31	Heat - Zone 16 Active	0	1	---

<b>EVR Fieldbus Map 2006192 and 2006194</b>						
<b>Automation Inputs (signal from EVR to PLC)</b>						
<b>Data Type</b>	<b>Byte</b>	<b>Bit</b>	<b>Description</b>	<b>Minimum Value</b>	<b>Maximum Value</b>	<b>Additional Info</b>
DINT	108-111	0	Heat - Zone 1 - Alarm Present	0	1	---
		1	Heat - Zone 2 - Alarm Present	0	1	---
		2	Heat - Zone 3 - Alarm Present	0	1	---
		3	Heat - Zone 4 - Alarm Present	0	1	---
		4	Heat - Zone 5 - Alarm Present	0	1	---
		5	Heat - Zone 6 - Alarm Present	0	1	---
		6	Heat - Zone 7 - Alarm Present	0	1	---
		7	Heat - Zone 8 - Alarm Present	0	1	---
		8	Heat - Zone 9 - Alarm Present	0	1	---
		9	Heat - Zone 10 - Alarm Present	0	1	---
		10	Heat - Zone 11 - Alarm Present	0	1	---
		11	Heat - Zone 12 - Alarm Present	0	1	---
		12	Heat - Zone 13 - Alarm Present	0	1	---
		13	Heat - Zone 14 - Alarm Present	0	1	---
		14	Heat - Zone 15 - Alarm Present	0	1	---
		15	Heat - Zone 16 - Alarm Present	0	1	---
				16-31	Reserved Bits 16-31	---
DINT	112-115	0-15	Heat - Zone 1 - Actual Temperature	0	500.0	XXX.X deg C
		16-31	Heat - Zone 2 - Actual Temperature	0	500.0	XXX.X deg C
DINT	116-119	0-15	Heat - Zone 3 - Actual Temperature	0	500.0	XXX.X deg C
		16-31	Heat - Zone 4 - Actual Temperature	0	500.0	XXX.X deg C
DINT	120-123	0-15	Heat - Zone 5 - Actual Temperature	0	500.0	XXX.X deg C
		16-31	Heat - Zone 6 - Actual Temperature	0	500.0	XXX.X deg C
DINT	124-127	0-15	Heat - Zone 7 - Actual Temperature	0	500.0	XXX.X deg C
		16-31	Heat - Zone 8 - Actual Temperature	0	500.0	XXX.X deg C
DINT	128-131	0-15	Heat - Zone 9 - Actual Temperature	0	500.0	XXX.X deg C
		16-31	Heat - Zone 10 - Actual Temperature	0	500.0	XXX.X deg C
DINT	132-135	0-15	Heat - Zone 11 - Actual Temperature	0	500.0	XXX.X deg C
		16-31	Heat - Zone 12 - Actual Temperature	0	500.0	XXX.X deg C
DINT	136-139	0-15	Heat - Zone 13 - Actual Temperature	0	500.0	XXX.X deg C
		16-31	Heat - Zone 14 - Actual Temperature	0	500.0	XXX.X deg C
DINT	140-143	0-15	Heat - Zone 15 - Actual Temperature	0	500.0	XXX.X deg C
		16-31	Heat - Zone 16 - Actual Temperature	0	500.0	XXX.X deg C

<b>EVR Fieldbus Map 2006192 and 2006194</b>						
<b>Automation Inputs (signal from EVR to PLC)</b>						
<b>Data Type</b>	<b>Byte</b>	<b>Bit</b>	<b>Description</b>	<b>Minimum Value</b>	<b>Maximum Value</b>	<b>Additional Info</b>
DINT	144-147	0-15	Heat - Longest Soak Time Remaining	0	7200	XXXXX seconds
		16-31	Heat - Idle Time Countdown	0	7200	XXXX seconds
DINT	148-151	0	Heat - System Alarm - Communication Lost - Heat Controller Dial Position 0	0	1	CBH1
		1	Heat - System Alarm - Communication Lost - Heat Controller Dial Position 1	0	1	CBH2
		2	Heat - System Alarm - Reserved Alarm Bool 2-7	---	---	---
		8	Heat - System Alarm - Communication Lost - Advanced Display Module	0	1	CBAX
		9	Heat - System Alarm - Communication Lost - CGM to Heat Link	0	1	CBGX
		10	Heat - System Alarm - Communication Lost - CGM to PLC Link	0	1	CCFX
		11	Heat - System Alarm - Main AMZ Invalid Line Voltage	0	1	V6H1
		12	Heat - System Alarm - Main AMZ Line Voltage Above Threshold	0	1	V4H1
		13	Heat - System Alarm - Reserved 13	---	---	---
		14	Heat - System Alarm - Main AMZ Transformer Temperature Above Threshold	0	1	T4TX
		15-19	System Heat Module - Reserved Alarm Bool 15-19	---	---	---
		20	Heat - System Alarm - Expansion AMZ Invalid Line Voltage	0	1	V6H2
		21	Heat - System Alarm - Expansion AMZ Line Voltage Above Threshold	0	1	V4H2
		22-31	System Heat Module - Reserved Alarm Bool 23-31	---	---	---

<b>EVR Fieldbus Map 2006192 and 2006194</b>						
<b>Automation Inputs (signal from EVR to PLC)</b>						
<b>Data Type</b>	<b>Byte</b>	<b>Bit</b>	<b>Description</b>	<b>Minimum Value</b>	<b>Maximum Value</b>	<b>Additional Info</b>
DINT	152-155	0	Heat - System Deviation - Reserved Bool 0	---	---	---
		1	Heat - System Deviation - Main AMZ Line Voltage Below Threshold	0	1	V2H1
		2	Heat - System Deviation - Fan Current Below Threshold	0	1	A2VX
		3	Heat - System Deviation - Fan Current Above Threshold	0	1	A3VX
		4	Heat - System Deviation - Transformer Temperature Above Threshold	0	1	T3TX
		5	Heat - System Deviation - Transformer Temperature Runaway	0	1	T9TX
		6		0	1	T6TX
		7-16	Heat - System Deviation - Reserved Deviation Bool 7-16	---	---	---
		17	Heat - System Deviation - Transformer Sensor Malfunction	0	1	V2H2
		18-31	Heat - System Deviation - Reserved Deviation Bool 18-31	---	---	---
DINT	156-159	0	Heat - System Advisory - Fan Filter Cleaning Request	0	1	MGFX
		1-31	Heat - System Advisory - Reserved Advisory Bool 1-31	---	---	---
DINT	160-163	0-31	Reserved Bits 0-31	---	---	---
DINT	164-167	0-7	Heat Zone Multiplexer: * - Zone On Display	1	16	0 = Invalid Data
		8	Heat Zone Multiplexer: * - Warm Up	0	1	---
		9	Heat Zone Multiplexer: * - Heat Soak	0	1	---
		10	Heat Zone Multiplexer: * - At Temperature	0	1	---
		11	Heat Zone Multiplexer: * - Setback	0	1	---
		12	Heat Zone Multiplexer: * - Deviation/Advisory Present	0	1	---
		13	Heat Zone Multiplexer: * - Alarm Present	0	1	---
		14-15	Heat Zone Multiplexer: * - Reserved Bool 14-15	---	---	---
		16-31	Heat Zone Multiplexer: * - Heat Soak Time Remaining (XXXX seconds)	0	7200	---
DINT	168-171	0-15	Heat Zone Multiplexer: * - Actual Current Usage (XX.X Amps)	0	30	---
		16-31	Heat Zone Multiplexer: * - Actual Duty Cycle (XXX %)	0	100	---

<b>EVR Fieldbus Map 2006192 and 2006194</b>						
<b>Automation Inputs (signal from EVR to PLC)</b>						
<b>Data Type</b>	<b>Byte</b>	<b>Bit</b>	<b>Description</b>	<b>Minimum Value</b>	<b>Maximum Value</b>	<b>Additional Info</b>
DINT	172-175	0-15	Heat Zone Multiplexer: * - Setpoint Temperature (XXX deg C)	0	70	---
		16-31	Heat Zone Multiplexer: * - Setback Temperature (XXX deg C)	0	70	---
DINT	176-179	0-7	Heat Zone Multiplexer: * - Heat Soak Time (XXX minutes)	0	120	---
		8-15	Heat Zone Multiplexer: * - Zone Profile	1	5	0 = Hose 1 = Valve 2 = Manifold 3 = PGM 4 = Flowmeter 5 = Press Reg
		16	Heat Zone Multiplexer: * - Alarm - Temperature Above System Limit	0	1	T4A_
		17	Heat Zone Multiplexer: * - Alarm - Temperature Above Threshold	0	1	T4A_
		18	Heat Zone Multiplexer: * - Alarm - Temperature Below Threshold	0	1	T1A_
		19	Heat Zone Multiplexer: * - Alarm - No Temperature Rise	0	1	T8A_
		20	Heat Zone Multiplexer: * - Alarm - Over Temperature Switch	0	1	T9A_
		21	Heat Zone Multiplexer: * - Alarm - Current Above Threshold	0	1	A4A_
		22	Heat Zone Multiplexer: * - Alarm - Current Below Threshold	0	1	A1A_
		23	Heat Zone Multiplexer: * - Alarm - No Current	0	1	A8A_
		24	Heat Zone Multiplexer: * - Unexpected Current	0	1	A7A_
		25	Heat Zone Multiplexer: * - Temperature Sensor Error	0	1	T6A_
		26-31	Heat Zone Multiplexer: * - Alarm - Reserved Alarm Bool 26-31	---	---	---

<i>EVR Fieldbus Map 2006192 and 2006194</i>						
<b>Automation Inputs (signal from EVR to PLC)</b>						
<b>Data Type</b>	<b>Byte</b>	<b>Bit</b>	<b>Description</b>	<b>Minimum Value</b>	<b>Maximum Value</b>	<b>Additional Info</b>
DINT	180-183	0-15	Heat Zone Multiplexer: * - Deviation - Reserved Bool 0-15	---	---	---
		16	Heat Zone Multiplexer: * - Advisory - Temperature Above System Limit	0	1	T3A_
		17	Heat Zone Multiplexer: * - Advisory - Temperature Above Threshold	0	1	T3A_
		18	Heat Zone Multiplexer: * - Advisory - Temperature Below Threshold	0	1	T2A_
		19	Heat Zone Multiplexer: * - Advisory - Reserved Advisory Bool 3	---	---	---
		20	Heat Zone Multiplexer: * - Advisory - Current Above Threshold	0	1	A3A_
		21	Heat Zone Multiplexer: * - Advisory - Current Below Threshold	0	1	A2A_
		22-31	Heat Zone Multiplexer: * - Advisory - Reserved Advisory Bool 22-31	---	---	---

**NOTES:**

*The data outlined in red is required to create a recipe.*

*△ Red Tank Stand Level Least Significant Bool (LSB) is bool 24, and the Most Significant Bool (MSB) is bool 25 of DINT.*

*☆ Blue Tank Stand Level Least Significant Bool (LSB) is bool 27, and the Most Significant Bool (MSB) is bool 28 of DINT.*

*∞ Use the “System is Recirculating” Bool to know what recirculation time is counting down.*

*\* Zone Multiplexer: Shows detailed information for the specified zone.*

*\_ Shown as 1-8 corresponding to the zone being looked up.*



## PLC Automation Outputs

**NOTE:** Print the following tables in color.

**NOTE:** The ambient map is only made up of the EVR signals highlighted in green. The heated map is made up of both the EVR signals highlighted in green, and the heat signals highlighted in yellow.

Key
EVR Signals
Heat Signals

<i>EVR Fieldbus Map 2006192 and 2006194</i>						
<b>Automation Outputs (signal from PLC to EVR)</b>						
<b>Data Type</b>	<b>Byte</b>	<b>Bit</b>	<b>Description</b>	<b>Minimum Value</b>	<b>Maximum Value</b>	<b>Additional Information</b>
DINT	0-3	0-31	ADM Date Requested	0	16777215	See <b>Time and Date</b> on page 97 for more information.
DINT	4-7	0-31	ADM Time Requested	0	16777215	
DINT	8-11	0	PLC Lockout Request *	0	1	---
		1	Gateway Recipe Lockout Request	0	1	---
		2	Acknowledge All Errors Request	0	1	---
		3	System Enable Request	0	1	---
		4	Operator Dispense/ Shot Request ♦ (Use discrete signal for proper timing)	0	1	---
		5	Cancel Shot Request	0	1	---
		6	Purge Request	0	1	---
		7	Base Purge Request	0	1	---
		8	Depressurization Request	0	1	---
		9	Park Request	0	1	---
		10	Recirculation Request	0	1	---
		11	Cancel Gel Shot Request	0	1	---
		12	Red Tank Stand Fill Request	0	1	---
		13	Blue Tank Stand Fill Request	0	1	---
		14	Voltex Motor On Request	0	1	---
		15	Voltex Air Injection Open Request	0	1	---
		16	Acknowledge Setup Value(s) Changed	0	1	---
17	Acknowledge Counter Value(s) Reset	0	1	---		
		18-31	Reserved Bool 18-31	---	---	---

<b>EVR Fieldbus Map 2006192 and 2006194</b>						
<b>Automation Outputs (signal from PLC to EVR)</b>						
<b>Data Type</b>	<b>Byte</b>	<b>Bit</b>	<b>Description</b>	<b>Minimum Value</b>	<b>Maximum Value</b>	<b>Additional Information</b>
DINT	12-15	0-7	Active Module Errors to Look Up	1	5	1 = Red MCM 2 = Blue MCM 3 = Red Tank Stand 4 = Blue Tank Stand 5 = Voltex
		8-15	Desired Recipe	1	50	---
		16-31	Desired System Ratio	1.00	160.00	X.XX : 1.00
DINT	16-19	0-15	Desired System Ratio Offset	-0.50	0.50	-/+ X.XX
		16-31	Gateway Recipe - Flowrate	0.00	200.00	XXX.XX cc/sec
DINT	20-23	0-31	Gateway Recipe - Shot Size	0.00	9999.99	XXXX.XX cc
DINT	24-27	0-7	Gateway Recipe - Dispense Type	0	1	0=Shot 1=Operator
		8-15	Recipe To Look Up	0	50	---
		16-31	Reserved Bits 16-31	---	---	---
DINT	28-31	0-31	Reserved Bits 0-31	---	---	---
DINT	32-35	0-15	Desired Data Exchange Element	0	32,767	---
DINT	36-39	0-31	Desired Data Exchange Element Value	See <b>Data Exchange</b> on page 87 for Min and Max Values.		---
<b>Transition to Heated Map 2006192</b>						
DINT	40-43	0-15	Heat - Data Exchange - Element	0	32,767	---
DINT	44-47	0-31	Heat - Data Exchange - Element Value	See <b>Data Exchange</b> on page 87 for Min and Max Values.		---

<b><i>EVR Fieldbus Map 2006192 and 2006194</i></b>						
<b>Automation Outputs (signal from PLC to EVR)</b>						
<b>Data Type</b>	<b>Byte</b>	<b>Bit</b>	<b>Description</b>	<b>Minimum Value</b>	<b>Maximum Value</b>	<b>Additional Information</b>
DINT	48-51	0	Reserved Bool 0	0	1	---
		1	Reserved Bool 1	0	1	---
		2	System Heat On Request	0	1	---
		3	System Heat Off Request	0	1	---
		4	System Heat Setback Request	0	1	---
		5	System Heat Acknowledge / Clear Errors	0	1	---
		6	Strobe New Installed Zones	0	1	---
		7	Strobe New Setpoint Temperature(s)	0	1	---
		8	Strobe New Setback Temperature(s)	0	1	---
		9	Strobe New Heatsoak Time(s)	0	1	---
		10	Reset System Heat Off Reason	0	1	Automatically resets when heat is turned on.
		11	Reset System Idle Timer	0	1	Automatically resets when pump motion is detected.
		12-15	Reserved Bool 10-15	0	1	---
		16	Install Zone 1	0	1	---
		17	Install Zone 2	0	1	---
		18	Install Zone 3	0	1	---
		19	Install Zone 4	0	1	---
		20	Install Zone 5	0	1	---
		21	Install Zone 6	0	1	---
		22	Install Zone 7	0	1	---
		23	Install Zone 8	0	1	---
		24	Install Zone 9	0	1	---
		25	Install Zone 10	0	1	---
		26	Install Zone 11	0	1	---
		27	Install Zone 12	0	1	---
		28	Install Zone 13	0	1	---
		29	Install Zone 14	0	1	---
		30	Install Zone 15	0	1	---
		31	Install Zone 16	0	1	---

<b>EVR Fieldbus Map 2006192 and 2006194</b>						
<b>Automation Outputs (signal from PLC to EVR)</b>						
<b>Data Type</b>	<b>Byte</b>	<b>Bit</b>	<b>Description</b>	<b>Minimum Value</b>	<b>Maximum Value</b>	<b>Additional Information</b>
DINT	52-55	0	Update Setpoint Temperature Zone 1	0	1	---
		1	Update Setpoint Temperature Zone 1	0	1	---
		2	Update Setpoint Temperature Zone 3	0	1	---
		3	Update Setpoint Temperature Zone 4	0	1	---
		4	Update Setpoint Temperature Zone 5	0	1	---
		5	Update Setpoint Temperature Zone 6	0	1	---
		6	Update Setpoint Temperature Zone 7	0	1	---
		7	Update Setpoint Temperature Zone 8	0	1	---
		8	Update Setpoint Temperature Zone 9	0	1	---
		9	Update Setpoint Temperature Zone 10	0	1	---
		10	Update Setpoint Temperature Zone 11	0	1	---
		11	Update Setpoint Temperature Zone 12	0	1	---
		12	Update Setpoint Temperature Zone 13	0	1	---
		13	Update Setpoint Temperature Zone 14	0	1	---
		14	Update Setpoint Temperature Zone 15	0	1	---
		15	Update Setpoint Temperature Zone 16	0	1	---
		16-31	New Setpoint Temperature (XX Deg C )	0	70	---

<b><i>EVR Fieldbus Map 2006192 and 2006194</i></b>						
<b>Automation Outputs (signal from PLC to EVR)</b>						
<b>Data Type</b>	<b>Byte</b>	<b>Bit</b>	<b>Description</b>	<b>Minimum Value</b>	<b>Maximum Value</b>	<b>Additional Information</b>
DINT	56-59	0	Update Setback Temperature Zone 1	0	1	---
		1	Update Setback Temperature Zone 2	0	1	---
		2	Update Setback Temperature Zone 3	0	1	---
		3	Update Setback Temperature Zone 4	0	1	---
		4	Update Setback Temperature Zone 5	0	1	---
		5	Update Setback Temperature Zone 6	0	1	---
		6	Update Setback Temperature Zone 7	0	1	---
		7	Update Setback Temperature Zone 8	0	1	---
		8	Update Setback Temperature Zone 9	0	1	---
		9	Update Setback Temperature Zone 10	0	1	---
		10	Update Setback Temperature Zone 11	0	1	---
		11	Update Setback Temperature Zone 12	0	1	---
		12	Update Setback Temperature Zone 13	0	1	---
		13	Update Setback Temperature Zone 14	0	1	---
		14	Update Setback Temperature Zone 15	0	1	---
		15	Update Setback Temperature Zone 16	0	1	---
		16-31	New Setback Temperature (XX Deg C )	0	70	---

<b>EVR Fieldbus Map 2006192 and 2006194</b>						
<b>Automation Outputs (signal from PLC to EVR)</b>						
<b>Data Type</b>	<b>Byte</b>	<b>Bit</b>	<b>Description</b>	<b>Minimum Value</b>	<b>Maximum Value</b>	<b>Additional Information</b>
DINT	60-63	0	Update Heatsoak Time Zone 1	0	1	---
		1	Update Heatsoak Time Zone 2	0	1	---
		2	Update Heatsoak Time Zone 3	0	1	---
		3	Update Heatsoak Time Zone 4	0	1	---
		4	Update Heatsoak Time Zone 5	0	1	---
		5	Update Heatsoak Time Zone 6	0	1	---
		6	Update Heatsoak Time Zone 7	0	1	---
		7	Update Heatsoak Time Zone 8	0	1	---
		8	Update Heatsoak Time Zone 9	0	1	---
		9	Update Heatsoak Time Zone 10	0	1	---
		10	Update Heatsoak Time Zone 11	0	1	---
		11	Update Heatsoak Time Zone 12	0	1	---
		12	Update Heatsoak Time Zone 13	0	1	---
		13	Update Heatsoak Time Zone 14	0	1	---
		14	Update Heatsoak Time Zone 15	0	1	---
		15	Update Heatsoak Time Zone 16	0	1	---
		16-30	New Heatsoak Time (XXX Minutes)	0	120	---
DINT	64-67	0-31	Reserved Bits 0-31	---	---	---
DINT	68-71	0-7	Heat Zone Multiplexer: Zone To Look Up	1	16	Shows detailed information for the specified zone (See Zone Multiplexer Segment)
		8-31	Reserved Bits 8-31	---	---	---

**NOTES:**

*The red box contains data that is required to create a recipe.*

\* *If set, control of the EVR from the ADM will be completely disabled.*

❖ *When in operator mode for recipe, the bit must be held high. If the bit is dropped low, the operator mode will be complete, dispensing will stop, and the dispense will be recorded in the shot log. If using a shot (cc mode) for the recipe, toggle the button to start the dispense as needed, and the shot can be canceled at any time using the stop recipe request.*

## Data Exchange

**NOTE:** For EVR Data Exchange timing diagrams, see FIG. 29 page 108.

EVR Fieldbus Map 2006192 and 2006194					
Data Exchange					
Command Value (base 10 decimal)	Name	Format and Units	Read/Write	Minimum Value	Maximum Value
1	Red MCM Active Alarms bitfield	bitfield	Read Only	0	4,294,967,296
2	Red MCM Active Deviations bitfield	bitfield	Read Only	0	4,294,967,296
3	Red MCM Active Advisories bitfield	bitfield	Read Only	0	4,294,967,296
4	Blue MCM Active Alarms bitfield	bitfield	Read Only	0	4,294,967,296
5	Blue MCM Active Deviations bitfield	bitfield	Read Only	0	4,294,967,296
6	Blue MCM Active Advisories bitfield	bitfield	Read Only	0	4,294,967,296
7	Pump Size A	XXXX.XX cc	Read/Write	1.00	160.00
8	Pump Size B	XXXX.XX cc	Read/Write	1.00	160.00
9	Purge and Base Purge Flow Rate	XXXX.XX cc/sec	Read/Write	0.00	200.00
10	Pressure Imbalance Alarm Enabled	Boolean	Read/Write	0	1
11	Pressure Imbalance Alarm Level	XXXX.XX bar	Read/Write	0.00	300.00
12	Red Pump Current Cycles ❖	XXXX cycles	Read/Write	0	2,147,483,647
13	Blue Pump Current Cycles ❖	XXXX cycles	Read/Write	0	2,147,483,647
14	Dispense Valve is Opened Cycles ❖	XXXX cycles	Read/Write	0	2,147,483,647
15	Red Pump Life Time Cycles	XXXX cycles	Read Only	0	2,147,483,647
16	Blue Pump Life Time Cycles	XXXX cycles	Read Only	0	2,147,483,647
17	Dispense Valve is Opened Life Time Cycles	XXXX cycles	Read Only	0	2,147,483,647
18	Red Pump Limit Cycles	XXXX cycles	Read/Write	0	2,147,483,647
19	Blue Pump Limit Cycles	XXXX cycles	Read/Write	0	2,147,483,647
20	Dispense Valve is Opened Limit Cycles	XXXX cycles	Read/Write	0	2,147,483,647
21	Recipe Look Up Number	Recipe XX	Read/Write	1	50
22	Recipe Look Up Shot Size	XXXX.XX cc	Read Only	0.00	9,999.99
23	Recipe Look Up Type	0 - Shot 1 - Operator	Read Only	0	1

<b>EVR Fieldbus Map 2006192 and 2006194</b>					
<b>Data Exchange</b>					
<b>Command Value (base 10 decimal)</b>	<b>Name</b>	<b>Format and Units</b>	<b>Read/Write</b>	<b>Minimum Value</b>	<b>Maximum Value</b>
24	Recipe Look Up Flowrate	XXXX.XX cc/sec	Read Only	0.00	200.00
25	Recipe Look Up Calibration	X.XX	Read Only	-99.990	99.990
26	Gel Timer Enabled	Boolean	Read/Write	0	1
27	Gel Timer Idle Period	XXXX sec- onds	Read/Write	0	9999
28	Gel Timer Alarm	XXXX sec- onds	Read/Write	0	9999
29	Gel Timer Amount	XXXX cc	Read/Write	0	9999
30	Gel Timer Flow Rate	XXXX.XX cc/sec	Read/Write	0	200.00
31	Gel Timer Remaining Time	XXXX sec- onds	Read Only	0	9999
32	System Ratio Direction	0 - Red(A) : 1 1 - Blue(B) : 1	Read/Write	0	1
33	System Valve Type	0 - MD2 1 - TC 2 - Voltex (Read Only)	Read/Write	0	2
34	System Base Purge Side	0 - Red(A) 1 - Blue(B)	Read/Write	0	1
35	Red Tank Stand Active Alarms bitfield	bitfield	Read Only	0	4,294,967,296
36	Red Tank Stand Active Devia- tions bitfield	bitfield	Read Only	0	4,294,967,296
37	Red Tank Stand Active Adviso- ries bitfield	bitfield	Read Only	0	4,294,967,296
38	Red Tank Stand Refill Setting	0 - Disable 1 - Monitor Only 2 - Manual Fill 3 - Auto Top-Off	Read/Write	0	3
39	Red Tank Stand Refill Timeout	minutes	Read/Write	0	99



EVR Fieldbus Map 2006192 and 2006194					
Data Exchange					
Command Value (base 10 decimal)	Name	Format and Units	Read/Write	Minimum Value	Maximum Value
40	Red Tank Stand Sensor Configuration	1 - Low and High Sensor Installed 2 - Low and Mid Sensor Installed 3 - Mid and High Sensor Installed 4 - Low, Mid and High Sensor Installed	Read/Write	1	4
41	Blue Tank Stand Active Alarms bitfield	bitfield	Read Only	0	4,294,967,296
42	Blue Tank Stand Active Deviations bitfield	bitfield	Read Only	0	4,294,967,296
43	Blue Tank Stand Active Advisories bitfield	bitfield	Read Only	0	4,294,967,296
44	Blue Tank Stand Refill Setting	0 - Disable 1 - Monitor Only 2 - Manual Fill 3 - Auto Top-Off	Read/Write	0	3
45	Blue Tank Stand Refill Timeout	minutes	Read/Write	0	99
46	Blue Tank Stand Sensor Configuration	1 - Low and High Sensor Installed 2 - Low and Mid Sensor Installed 3 - Mid and High Sensor Installed 4 - Low, Mid and High Sensor Installed	Read/Write	1	4
47	Recirculation Mode	0 - Disable 1 - Manual 2 - Timer	Read/Write	0	2
49	Recirculation Timer On Time	minutes	Read/Write	0	420
50	Recirculation Timer Off Time	minutes	Read/Write	0	420
51	Recirculation Timer Remaining	sec	Read Only	0	25,200
52	Park Using Recirculation Valves Enable	0 - Disable 1 - Enabled	Read/Write	0	1

<b>EVR Fieldbus Map 2006192 and 2006194</b>					
<b>Data Exchange</b>					
<b>Command Value (base 10 decimal)</b>	<b>Name</b>	<b>Format and Units</b>	<b>Read/Write</b>	<b>Minimum Value</b>	<b>Maximum Value</b>
53	Park After Recirculation is Completed Enable	0 - Disable 1 - Enabled	Read/Write	0	1
54	Voltex Active Alarms bitfield	bitfield	Read Only	0	4,294,967,296
55	Voltex Active Deviations bitfield	bitfield	Read Only	0	4,294,967,296
56	Voltex Active Advisories bitfield	bitfield	Read Only	0	4,294,967,296
57	Voltex Motor Target Speed	XXXX rpm	Read/Write	0	4400
58	Voltex Motor Ramp Up Time	XXXX ms	Read/Write	100	9000
59	Voltex EVR Dispense Wait Enable	0 - Disable 1 - Enabled	Read/Write	0	1
60	Voltex Air Nucleation Enable	0 - Disable 1 - Enabled	Read/Write	0	1
61	Voltex Air Nucleation Delay Time	XXXX ms	Read/Write	0	2000
62	Voltex Air Nucleation On Time	XXXX ms	Read/Write	0	9000
63	Voltex Air Nucleation Off Time	XXXX ms	Read/Write	0	9000
64	Voltex Actual Motor Speed	XXXX.X rpm	Read Only	0	4400.0
65	Voltex Red Valve Pressure	XXXX.X bar	Read Only	0	300.0
66	Voltex Blue Valve Pressure	XXXX.X bar	Read Only	0	300.0
67	Voltex Motor Spinning Disable for Dispensing	0 - Off 1 - On	Read/Write	0	1
68	Voltex Air Nucleation Disable for Dispensing	0 - Off 1 - On	Read/Write	0	1
69	Recirculation Pump Method Selected	0 - Both 1 - Red (A) 2 - Blue (B)	Read/Write	0	2
70	Recirculation Valve Control	0 - Automatic 1 - Manual	Read/Write	0	1
71	Synchronous Changeovers	0 - Disabled 1 - Enabled	Read/Write	0	1
72	Recirculation Flow Rate A	XXXX.XX cc/sec	Read/Write	0	70.00
73	Recirculation Flow Rate B	XXXX.XX cc/sec	Read/Write	0	70.00
74	Recirculation Installed	0 - None 1 - Both 2 - Red (A) 3 - Blue (B)	Read/Write	0	3
75	Dispense Pressure Alerts - Minimum Inlet Error Type	0 - Disabled 1 - Deviation 2 - Alarm	Read/Write	0	2

EVR Fieldbus Map 2006192 and 2006194					
Data Exchange					
Command Value (base 10 decimal)	Name	Format and Units	Read/Write	Minimum Value	Maximum Value
76	Dispense Pressure Alerts - Minimum Inlet Red Pump	XXX.XX bar	Read/Write	0.00	300.00
77	Dispense Pressure Alerts - Minimum Inlet Blue Pump	XXX.XX bar	Read/Write	0.00	300.00
78	Dispense Pressure Alerts - Maximum Inlet Error Type	0 - Disabled 1 - Deviation 2 - Alarm	Read/Write	0	2
79	Dispense Pressure Alerts - Maximum Inlet Red Pump	XXX.XX bar	Read/Write	0.00	300.00
80	Dispense Pressure Alerts - Maximum Inlet Blue Pump	XXX.XX bar	Read/Write	0.00	300.00
81	Dispense Pressure Alerts - Minimum Outlet Error Type	0 - Disabled 1 - Deviation 2 - Alarm	Read/Write	0	2
82	Dispense Pressure Alerts - Minimum Outlet Red Pump	XXX.XX bar	Read/Write	0.00	300.00
83	Dispense Pressure Alerts - Minimum Outlet Blue Pump	XXX.XX bar	Read/Write	0.00	300.00
84	Dispense Pressure Alerts - Maximum Outlet Error Type	0 - Disabled 1 - Deviation 2 - Alarm	Read/Write	0	2
85	Dispense Pressure Alerts - Maximum Outlet Red Pump	XXX.XX bar	Read/Write	0.00	300.00
86	Dispense Pressure Alerts - Maximum Outlet Blue Pump	XXX.XX bar	Read/Write	0.00	300.00

**NOTES:**

❖ Send a "1" to reset the counters to zero.

Sending a command value of "0" will return the maximum value (0xFFFFFFFF).

## Heat Data Exchange

**NOTE:** For Heat Data Exchange timing diagrams, see FIG. 35 page 111.

EVR Fieldbus Map 2006192					
Heat Data Exchange					
Command Value (base 10 decimal)	Name	Format and Units	Read/Write	Minimum Value	Maximum Value
1	System Heat Zone 1 Heat Rate	0 = Normal 1 = Slow 2 = Fast	Read/Write	0	2
2	System Heat Zone 1 High Temperature Alarm Offset	XX - Whole Deg C	Read/Write	2	30
3	System Heat Zone 1 High Temperature Deviation Offset	XX - Whole Deg C	Read/Write	1	29
4	System Heat Zone 1 Low Temperature Deviation Offset	XX - Whole Deg C	Read/Write	1	29
5	System Heat Zone 1 Low Temperature Alarm Offset	XX - Whole Deg C	Read/Write	2	30
6	System Heat Zone 2 Heat Rate	0 = Normal 1 = Slow 2 = Fast	Read/Write	0	2
7	System Heat Zone 2 High Temperature Alarm Offset	XX - Whole Deg C	Read/Write	2	30
8	System Heat Zone 2 High Temperature Deviation Offset	XX - Whole Deg C	Read/Write	1	29
9	System Heat Zone 2 Low Temperature Deviation Offset	XX - Whole Deg C	Read/Write	1	29
10	System Heat Zone 2 Low Temperature Alarm Offset	XX - Whole Deg C	Read/Write	2	30
11	System Heat Zone 3 Heat Rate	0 = Normal 1 = Slow 2 = Fast	Read/Write	0	2
12	System Heat Zone 3 High Temperature Alarm Offset	XX - Whole Deg C	Read/Write	2	30
13	System Heat Zone 3 High Temperature Deviation Offset	XX - Whole Deg C	Read/Write	1	29
14	System Heat Zone 3 Low Temperature Deviation Offset	XX - Whole Deg C	Read/Write	1	29
15	System Heat Zone 3 Low Temperature Alarm Offset	XX - Whole Deg C	Read/Write	2	30
16	System Heat Zone 4 Heat Rate	0 = Normal 1 = Slow 2 = Fast	Read/Write	0	2
17	System Heat Zone 4 High Temperature Alarm Offset	XX - Whole Deg C	Read/Write	2	30

EVR Fieldbus Map 2006192					
Heat Data Exchange					
Command Value (base 10 decimal)	Name	Format and Units	Read/Write	Minimum Value	Maximum Value
18	System Heat Zone 4 High Temperature Deviation Offset	XX - Whole Deg C	Read/Write	1	29
19	System Heat Zone 4 Low Temperature Deviation Offset	XX - Whole Deg C	Read/Write	1	29
20	System Heat Zone 4 Low Temperature Alarm Offset	XX - Whole Deg C	Read/Write	2	30
21	System Heat Zone 5 Heat Rate	0 = Normal 1 = Slow 2 = Fast	Read/Write	0	2
22	System Heat Zone 5 High Temperature Alarm Offset	XX - Whole Deg C	Read/Write	2	30
23	System Heat Zone 5 High Temperature Deviation Offset	XX - Whole Deg C	Read/Write	1	29
24	System Heat Zone 5 Low Temperature Deviation Offset	XX - Whole Deg C	Read/Write	1	29
25	System Heat Zone 5 Low Temperature Alarm Offset	XX - Whole Deg C	Read/Write	2	30
26	System Heat Zone 6 Heat Rate	0 = Normal 1 = Slow 2 = Fast	Read/Write	0	2
27	System Heat Zone 6 High Temperature Alarm Offset	XX - Whole Deg C	Read/Write	2	30
28	System Heat Zone 6 High Temperature Deviation Offset	XX - Whole Deg C	Read/Write	1	29
29	System Heat Zone 6 Low Temperature Deviation Offset	XX - Whole Deg C	Read/Write	1	29
30	System Heat Zone 6 Low Temperature Alarm Offset	XX - Whole Deg C	Read/Write	2	30
31	System Heat Zone 7 Heat Rate	0 = Normal 1 = Slow 2 = Fast	Read/Write	0	2
32	System Heat Zone 7 High Temperature Alarm Offset	XX - Whole Deg C	Read/Write	2	30
33	System Heat Zone 7 High Temperature Deviation Offset	XX - Whole Deg C	Read/Write	1	29
34	System Heat Zone 7 Low Temperature Deviation Offset	XX - Whole Deg C	Read/Write	1	29
35	System Heat Zone 7 Low Temperature Alarm Offset	XX - Whole Deg C	Read/Write	2	30
36	System Heat Zone 8 Heat Rate	0 = Normal 1 = Slow 2 = Fast	Read/Write	0	2

<b>EVR Fieldbus Map 2006192</b>					
<b>Heat Data Exchange</b>					
<b>Command Value (base 10 decimal)</b>	<b>Name</b>	<b>Format and Units</b>	<b>Read/Write</b>	<b>Minimum Value</b>	<b>Maximum Value</b>
37	System Heat Zone 8 High Temperature Alarm Offset	XX - Whole Deg C	Read/Write	2	30
38	System Heat Zone 8 High Temperature Deviation Offset	XX - Whole Deg C	Read/Write	1	29
39	System Heat Zone 8 Low Temperature Deviation Offset	XX - Whole Deg C	Read/Write	1	29
40	System Heat Zone 8 Low Temperature Alarm Offset	XX - Whole Deg C	Read/Write	2	30
41	System Heat Zone 9 Heat Rate	0 = Normal 1 = Slow 2 = Fast	Read/Write	0	2
42	System Heat Zone 9 High Temperature Alarm Offset	XX - Whole Deg C	Read/Write	2	30
43	System Heat Zone 9 High Temperature Deviation Offset	XX - Whole Deg C	Read/Write	1	29
44	System Heat Zone 9 Low Temperature Deviation Offset	XX - Whole Deg C	Read/Write	1	29
45	System Heat Zone 9 Low Temperature Alarm Offset	XX - Whole Deg C	Read/Write	2	30
46	System Heat Zone 10 Heat Rate	0 = Normal 1 = Slow 2 = Fast	Read/Write	0	2
47	System Heat Zone 10 High Temperature Alarm Offset	XX - Whole Deg C	Read/Write	2	30
48	System Heat Zone 10 High Temperature Deviation Offset	XX - Whole Deg C	Read/Write	1	29
49	System Heat Zone 10 Low Temperature Deviation Offset	XX - Whole Deg C	Read/Write	1	29
50	System Heat Zone 10 Low Temperature Alarm Offset	XX - Whole Deg C	Read/Write	2	30
51	System Heat Zone 11 Heat Rate	0 = Normal 1 = Slow 2 = Fast	Read/Write	0	2
52	System Heat Zone 11 High Temperature Alarm Offset	XX - Whole Deg C	Read/Write	2	30
53	System Heat Zone 11 High Temperature Deviation Offset	XX - Whole Deg C	Read/Write	1	29
54	System Heat Zone 11 Low Temperature Deviation Offset	XX - Whole Deg C	Read/Write	1	29
55	System Heat Zone 11 Low Temperature Alarm Offset	XX - Whole Deg C	Read/Write	2	30

EVR Fieldbus Map 2006192					
Heat Data Exchange					
Command Value (base 10 decimal)	Name	Format and Units	Read/Write	Minimum Value	Maximum Value
56	System Heat Zone 12 Heat Rate	0 = Normal 1 = Slow 2 = Fast	Read/Write	0	2
57	System Heat Zone 12 High Temperature Alarm Offset	XX - Whole Deg C	Read/Write	2	30
58	System Heat Zone 12 High Temperature Deviation Offset	XX - Whole Deg C	Read/Write	1	29
59	System Heat Zone 12 Low Temperature Deviation Offset	XX - Whole Deg C	Read/Write	1	29
60	System Heat Zone 12 Low Temperature Alarm Offset	XX - Whole Deg C	Read/Write	2	30
61	System Heat Zone 13 Heat Rate	0 = Normal 1 = Slow 2 = Fast	Read/Write	0	2
62	System Heat Zone 13 High Temperature Alarm Offset	XX - Whole Deg C	Read/Write	2	30
63	System Heat Zone 13 High Temperature Deviation Offset	XX - Whole Deg C	Read/Write	1	29
64	System Heat Zone 13 Low Temperature Deviation Offset	XX - Whole Deg C	Read/Write	1	29
65	System Heat Zone 13 Low Temperature Alarm Offset	XX - Whole Deg C	Read/Write	2	30
66	System Heat Zone 14 Heat Rate	0 = Normal 1 = Slow 2 = Fast	Read/Write	0	2
67	System Heat Zone 14 High Temperature Alarm Offset	XX - Whole Deg C	Read/Write	2	30
68	System Heat Zone 14 High Temperature Deviation Offset	XX - Whole Deg C	Read/Write	1	29
69	System Heat Zone 14 Low Temperature Deviation Offset	XX - Whole Deg C	Read/Write	1	29
70	System Heat Zone 14 Low Temperature Alarm Offset	XX - Whole Deg C	Read/Write	2	30
71	System Heat Zone 15 Heat Rate	0 = Normal 1 = Slow 2 = Fast	Read/Write	0	2
72	System Heat Zone 15 High Temperature Alarm Offset	XX - Whole Deg C	Read/Write	2	30
73	System Heat Zone 15 High Temperature Deviation Offset	XX - Whole Deg C	Read/Write	1	29
74	System Heat Zone 15 Low Temperature Deviation Offset	XX - Whole Deg C	Read/Write	1	29

EVR Fieldbus Map 2006192					
Heat Data Exchange					
Command Value (base 10 decimal)	Name	Format and Units	Read/Write	Minimum Value	Maximum Value
75	System Heat Zone 15 Low Temperature Alarm Offset	XX - Whole Deg C	Read/Write	2	30
76	System Heat Zone 16 Heat Rate	0 = Normal 1 = Slow 2 = Fast	Read/Write	0	2
77	System Heat Zone 16 High Temperature Alarm Offset	XX - Whole Deg C	Read/Write	2	30
78	System Heat Zone 16 High Temperature Deviation Offset	XX - Whole Deg C	Read/Write	1	29
79	System Heat Zone 16 Low Temperature Deviation Offset	XX - Whole Deg C	Read/Write	1	29
80	System Heat Zone 16 Low Temperature Alarm Offset	XX - Whole Deg C	Read/Write	2	30
81	System Heat Idle Timeout	XXX - minute	Read/Write	0	120

**NOTES:**

*Sending a command value of "0" will return the maximum value -1 (0xFFFFFFFF) to the Automation Inputs for the Data Exchange Element and Value.*



## Time and Date

The following diagram shows the data locations for sending and receiving the date and time across the fieldbus.

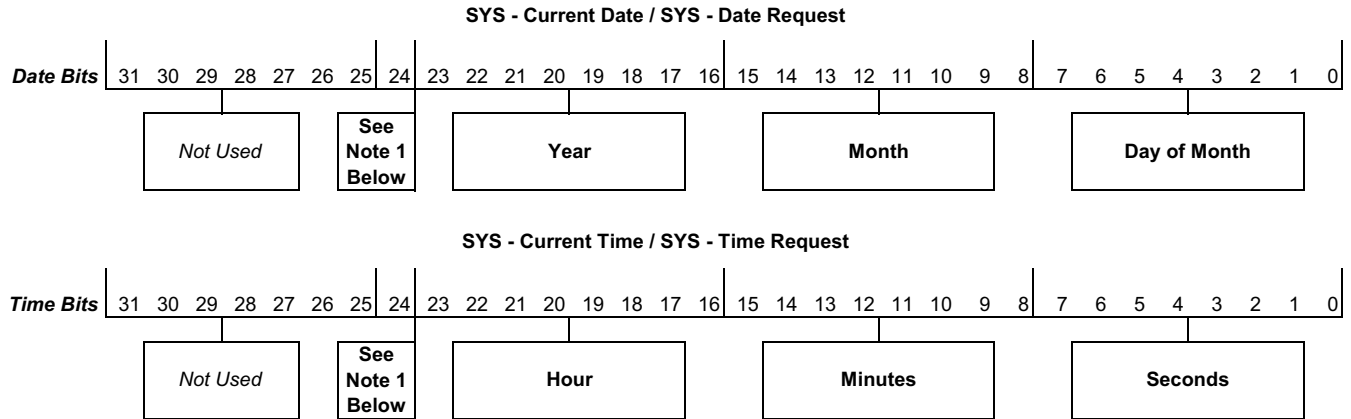

**NOTES:**

- 1 Bit 24 must be set high in order for the request of the internal date or time to be set. Once the request is sent, bit 24 must be set low, otherwise future requests will be ignored.
- 2 If an invalid date or time is requested, the request will be ignored.

## Active Module Error Look-Up Table

To utilize the Active Module Error Look-Up table, the PLC must perform a look-up operation to the EVR. Once the EVR obtains the look-up index, the EVR system will populate error data into Active Alarm, Deviation, and Advisory bitfields of the Active Module Error Look-Up on the **PLC Automation Inputs**, page 70, which is specific to the Active Module Error Look-Up index.

Once the index's errors have been pulled and the data populated, the EVR will place the index number into the Active Module Error Look-Up to indicate to the PLC that the data is valid for that index, and the data can be read.

The following table contains the list of look-up index options:

Look-Up Index	Module Errors
1	Red MCM
2	Blue MCM
3	Red Tank Stand
4	Blue Tank Stand
5	Voltex

**NOTE:** For Active Module Error Look-Up timing diagrams, see FIG. 17 on page 100. To acknowledge the errors, see FIG. 18 on page 100.

Every distinct bit corresponds to a unique error. The following tables contain a comprehensive list of errors for each module, along with their respective bit numbers.

**NOTE:** The underscore ( \_ ) in the error codes signify the side that triggered the error. The red side will be represented by "A," and the blue side will be represented by "B."

## MCM Errors

Alarms Bitfield		
Bit Number	Alarm Code	Alarm Name
0	P9D_	Max System Outlet Pressure Exceeded
1	P6D_	Outlet Pressure Sensor Disconnected
2	P7D_	Outlet Pressure Imbalance
3	V1N_	Line Voltage Below Threshold
4	V4N_	Line Voltage Above Threshold
5	T4N_	High Motor Temperature
6	T4N_	High Driver Temperature
7	WBN_	Motor Encoder Alarm
8	WMN_	Internal Driver Communication Issue
9	WMN_	General Driver Board Hardware Issue
10	WMN_	General Board Software Exception
11	A4N_	High Motor Current
12	P4D_	Dispense Window High Outlet Pressure
13	P1D_	Dispense Window Low Outlet Pressure
14	P4F_	Dispense Window High Inlet Pressure
15	P1F_	Dispense Window Low Inlet Pressure
16	WSNX	Invalidated Recipe
17	F4RX	Recipe Flow Exceeds Max Flow
18	F4PX	Purge Flow Exceeds Max Flow
19	F4GX	Gel Flow Exceeds Max Flow
20	F4CX	Recirculation Flow Exceeds Max Flow
21	P9FX	Max System Inlet Pressure Exceeded
N/A	CAM_	Comm. Error with Motor Controller

**NOTE:** \*\_ in the error code will be shown as “A” for the Red Side, or “B” for the Blue Side.

Deviation Bitfield		
Bit Number	Alarm Code	Alarm Name
0	P6F_	Inlet Pressure Transducer Disconnected
1	W5N_	Motor Encoder Not Calibrated
2	P3D_	Dispense Window High Outlet Pressure
3	P2D_	Dispense Window Low Outlet Pressure
4	P3F_	Dispense Window High Inlet Pressure
5	P2F_	Dispense Window Low Inlet Pressure
6	P7C_	Dispense Window Out of Range

### Tank Stand Errors

Deviation Bitfield		
Bit Number	Alarm Code	Alarm Name
0	L3T_	High Material Level
1	L2T_	Low Material Level
2	L6T_	Auto Refill Timeout
3	L1T_	Fill Sensor Fault

**NOTE:** \*\_ in the error code will be shown as “A” for the Red Side, or “B” for the Blue Side.

### Voltex Errors

Advisory Bitfield		
Bit Number	Alarm Code	Alarm Name
0	CAA_	Comm. Error Advanced Display
1	CAP_	Comm. Error Paired Motor
2	CAC_	Comm. Error Gateway
3	CCC_	Comm. Error Fieldbus Connection
4	F3N_	Unable to Maintain Flow Rate
5	MA0_	Pump Maintenance Due
6	MEDX	Dispense Valve Maintenance Due
7	---	Reserved
8	CATA	Comm. Error Red Tank
9	CATB	Comm. Error Blue Tank
10	CAFX	Comm. Error Fluid Control Module
11	CAVX	Comm. Error Voltex DMV
12	---	Reserved
13	---	Reserved
14	---	Reserved
15	CAK1	Comm. Error Heat Board
16	CALX	Comm. Error Heat I/O Board

Alarms Bitfield		
Bit Number	Alarm Code	Alarm Name
0	WVCX	Voltex Motor Fault

# CGM General Timing Diagrams

**NOTE:** A 50ms delay is suggested between each automation signal.

**NOTE:** When dispensing a bead, it is recommend that the discrete trigger signal be used instead of the fieldbus trigger signal, due to timing issues and delays with the fieldbus trigger. See **I/O Integration** on page 68 for location hookup details.

## Active Module Errors Look Up

Automation Inputs (EVR Outputs)

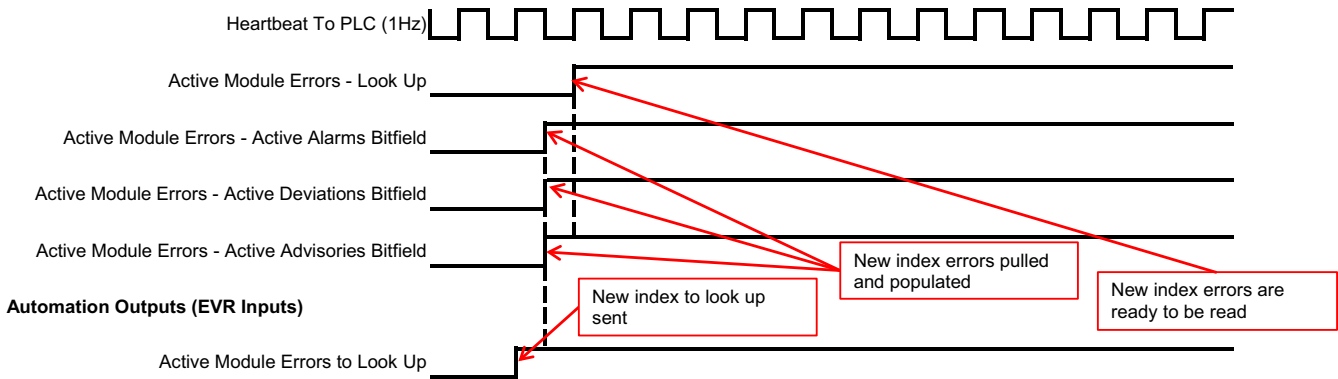

FIG. 17:

## EVR System Ack-Clear Errors

Automation Inputs (EVR Outputs)

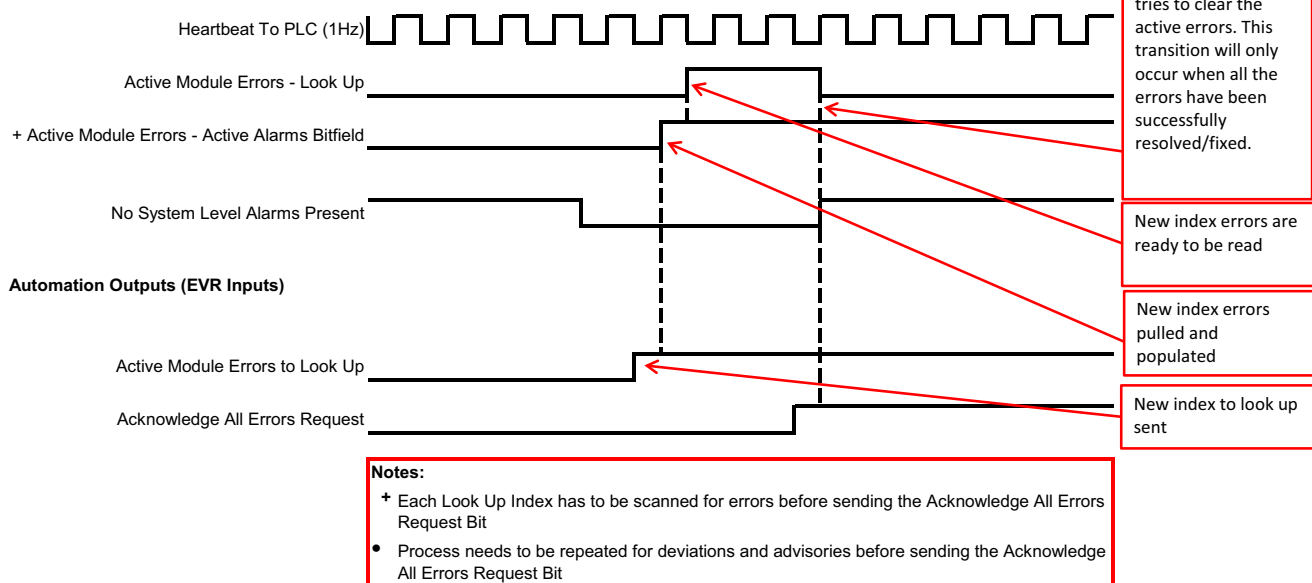
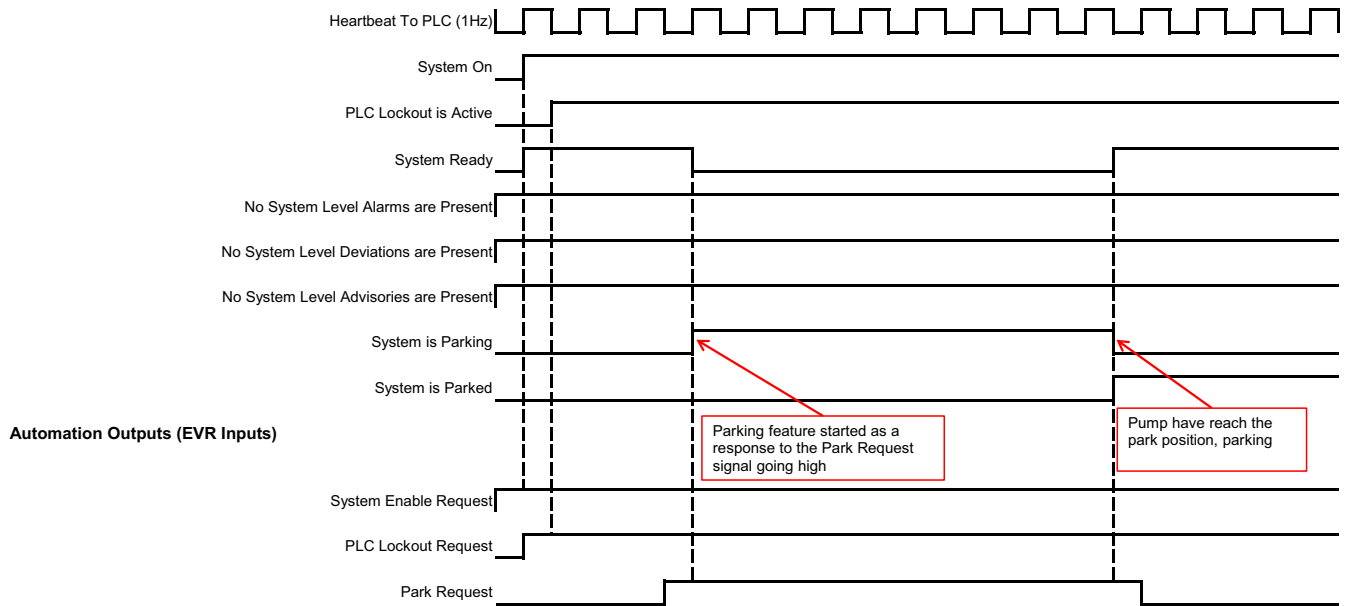

FIG. 18:

**System Parking Request**

Automation Inputs (EVR Outputs)



**FIG. 19:**

**System Purge Request**

Automation Inputs (EVR Outputs)

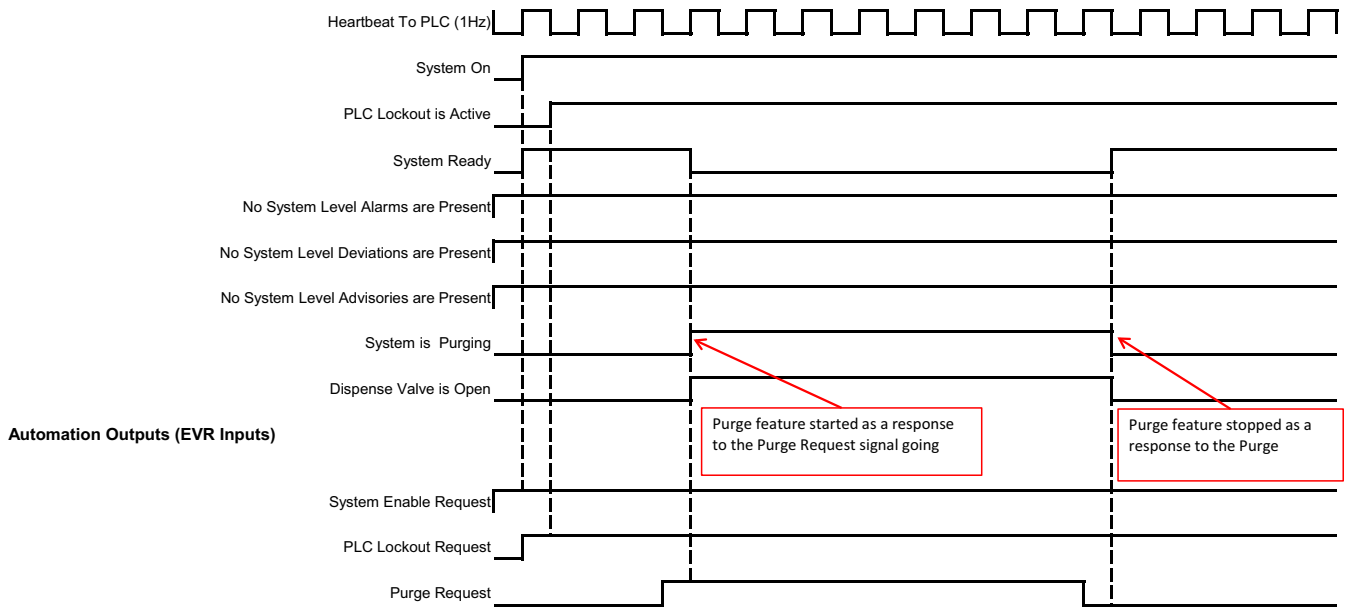

**FIG. 20:**

**System Base Purge Request**

**Automation Inputs (EVR Outputs)**

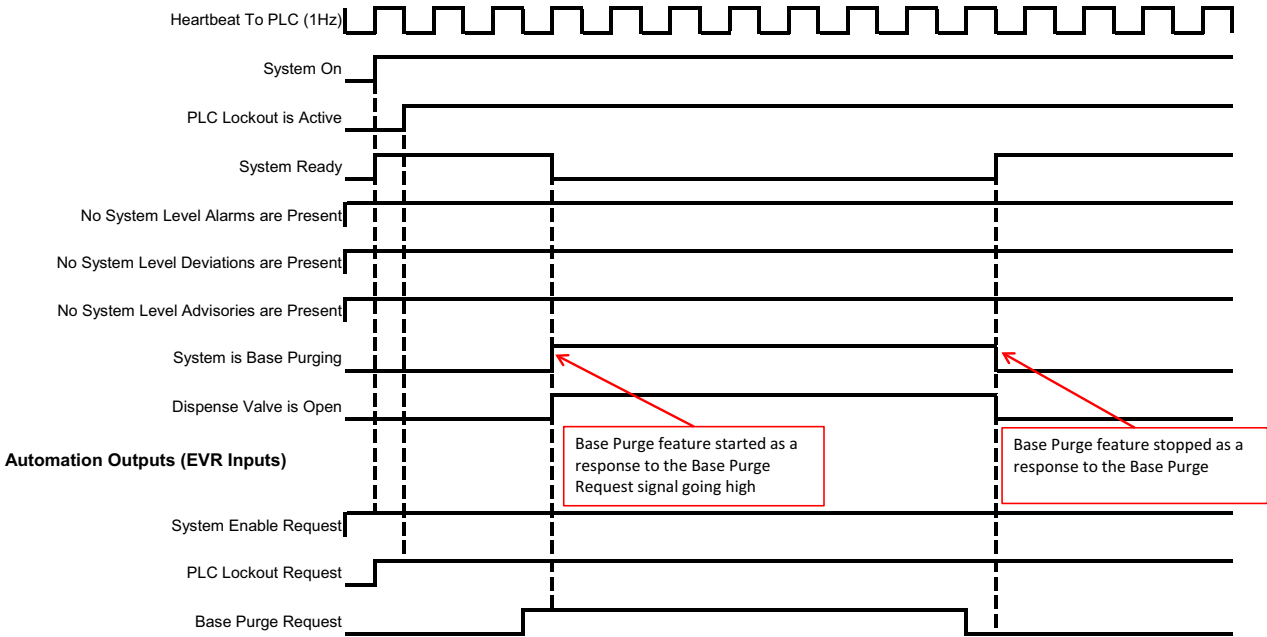

**FIG. 21:**

**System Depressurization Request**

**Automation Inputs (EVR Outputs)**

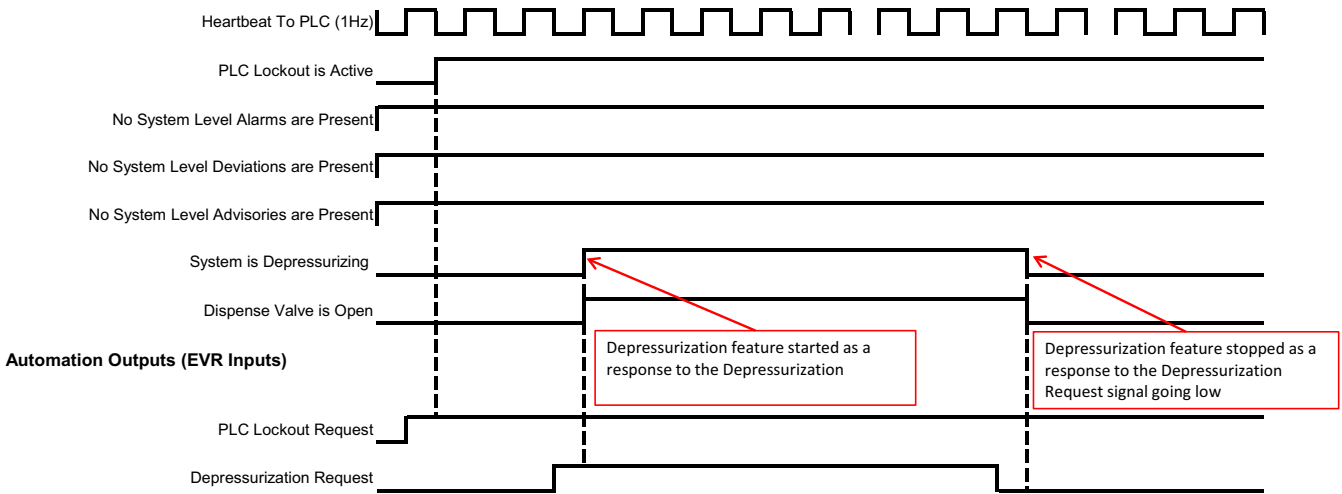

**FIG. 22:**

**System Recirculation Request**

**Automation Inputs (EVR Outputs)**

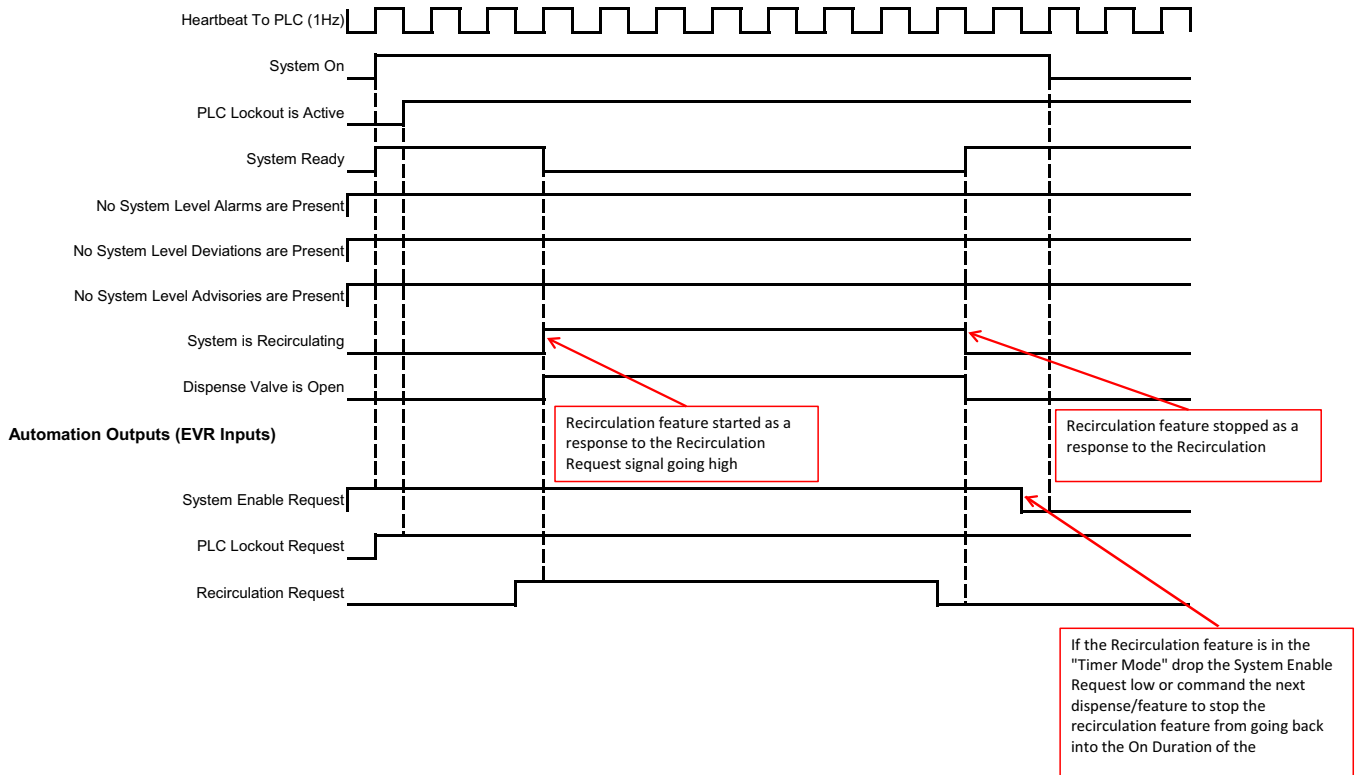

**FIG. 23:**

**Operator Recipe Dispense**

**Automation Inputs (EVR Outputs)**

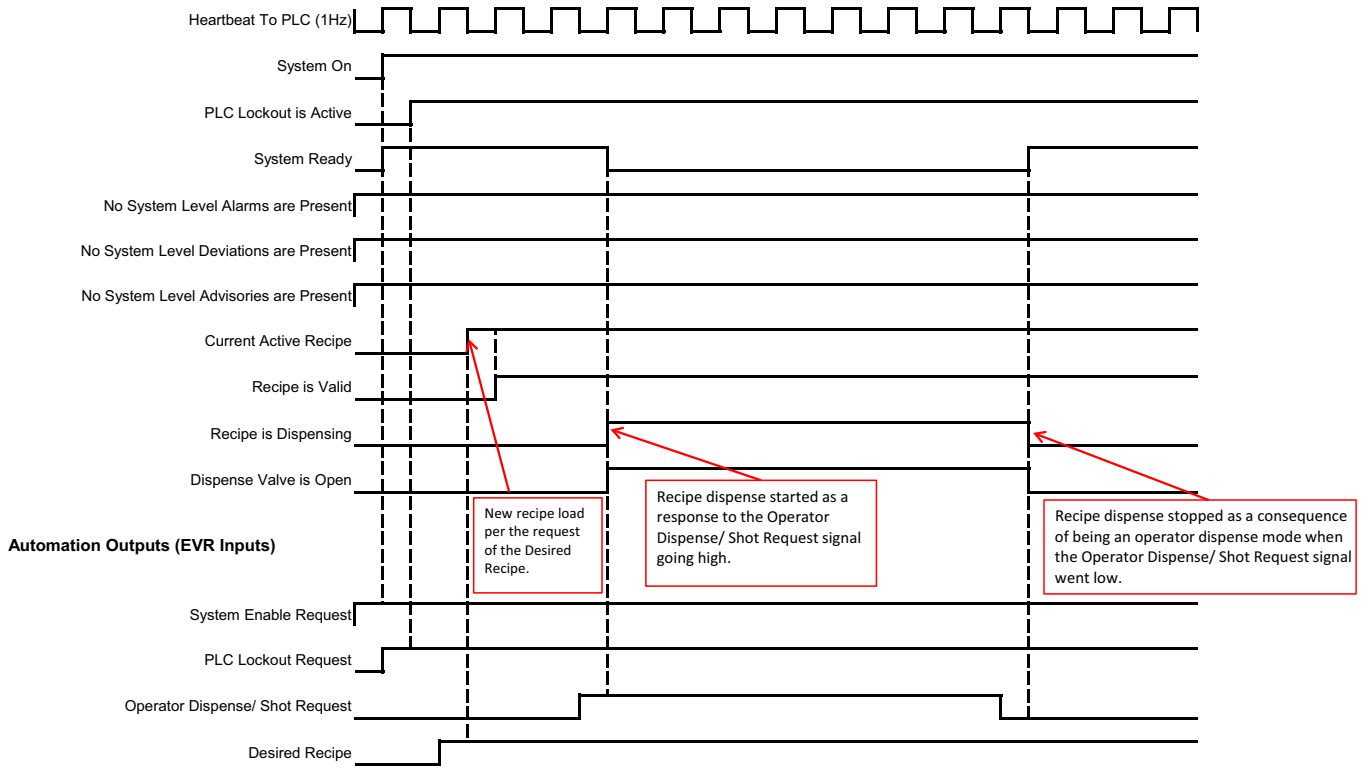
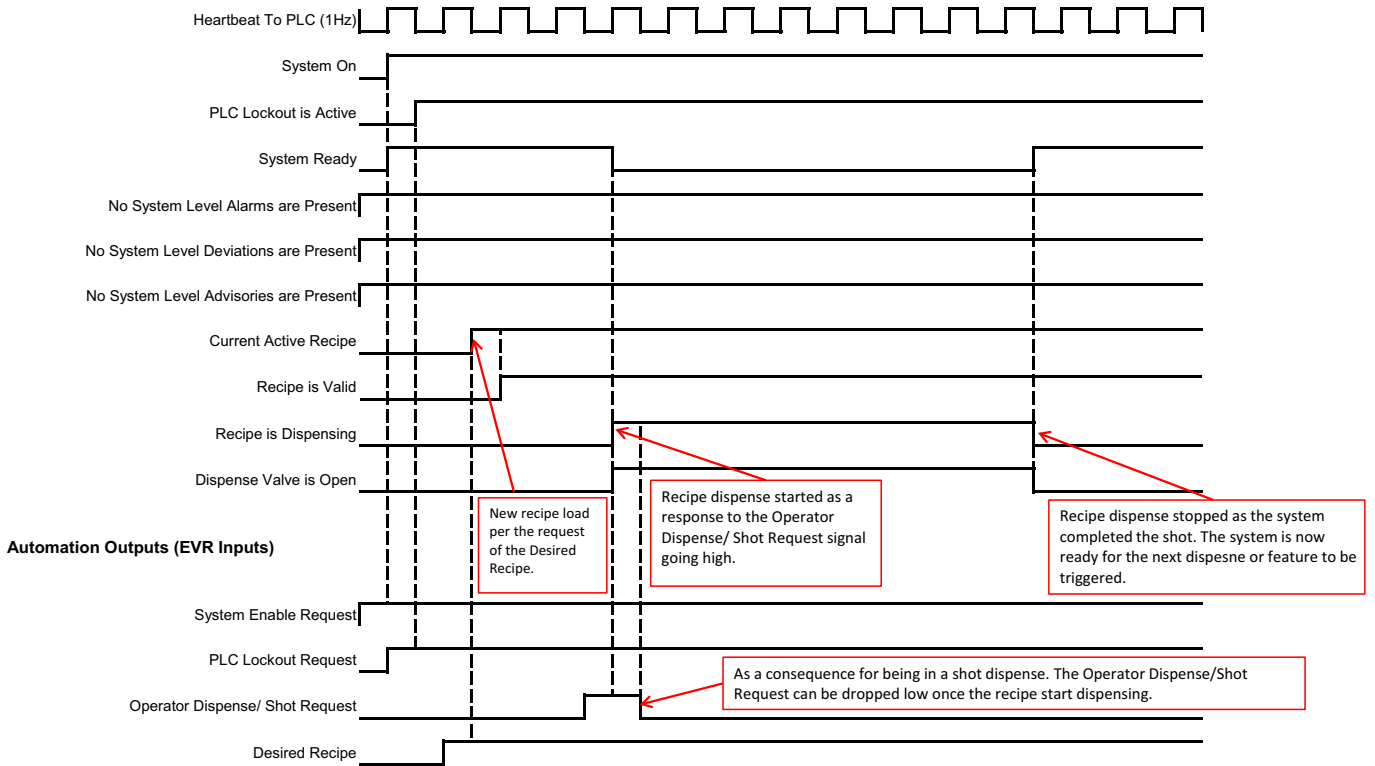

**FIG. 24:**



**Start Shot Recipe Dispense**

**Automation Inputs (EVR Outputs)**



**FIG. 25:**

**Stop Shot Recipe Dispense**

**Automation Inputs (EVR Outputs)**

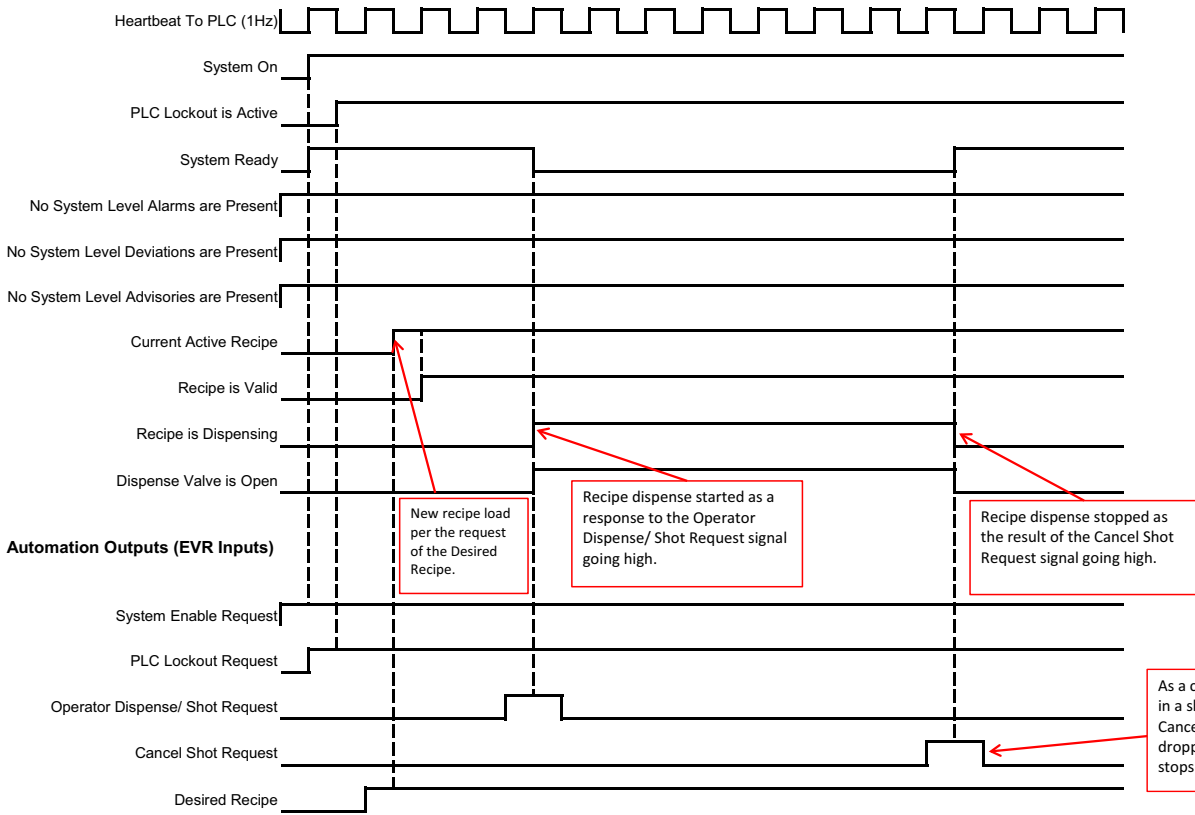

**FIG. 26:**

**Voltex Operator Recipe Dispense**

**Automation Inputs (EVR Outputs)**

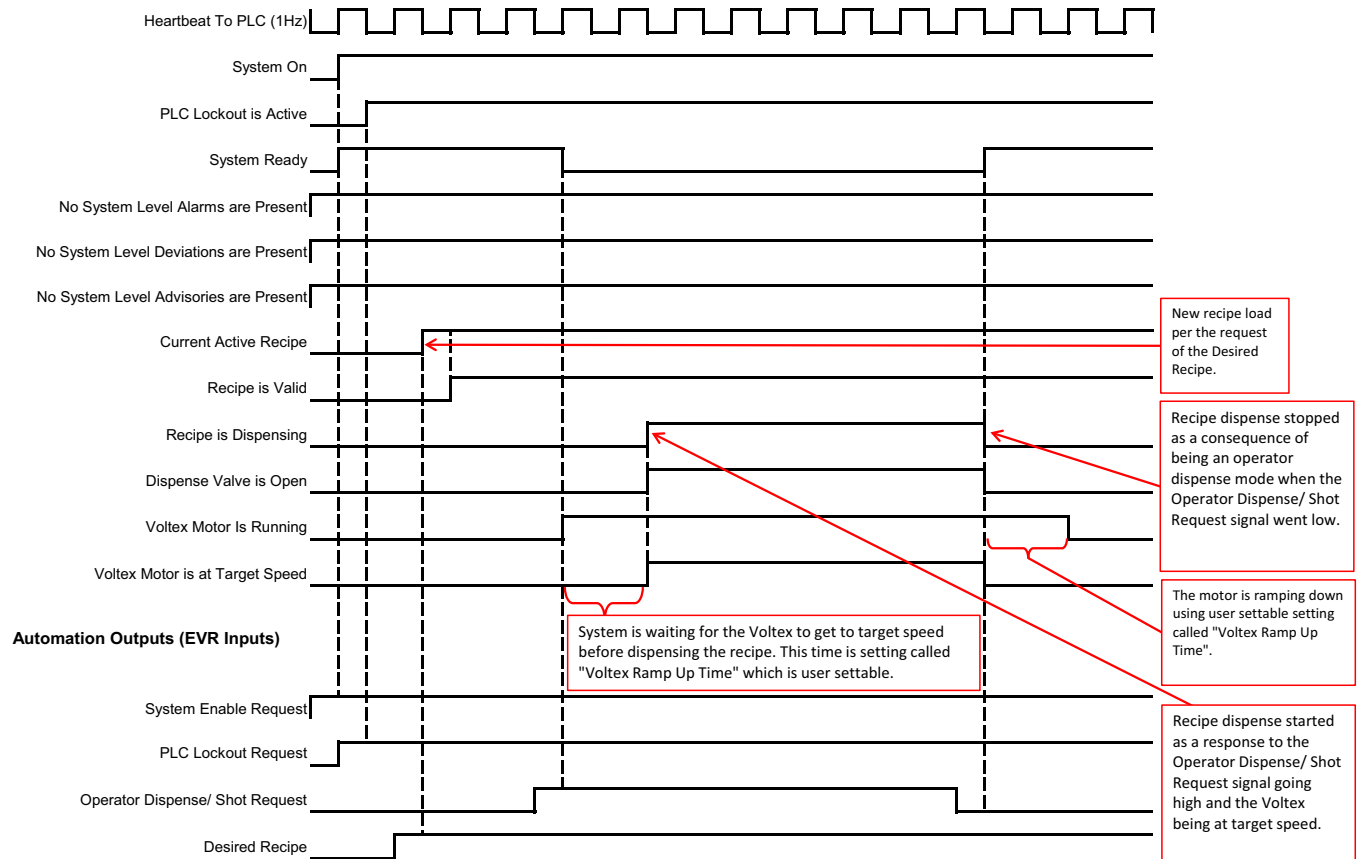

**FIG. 27:**

**Voltex Shot Recipe Dispense**

**Automation Inputs (EVR Outputs)**

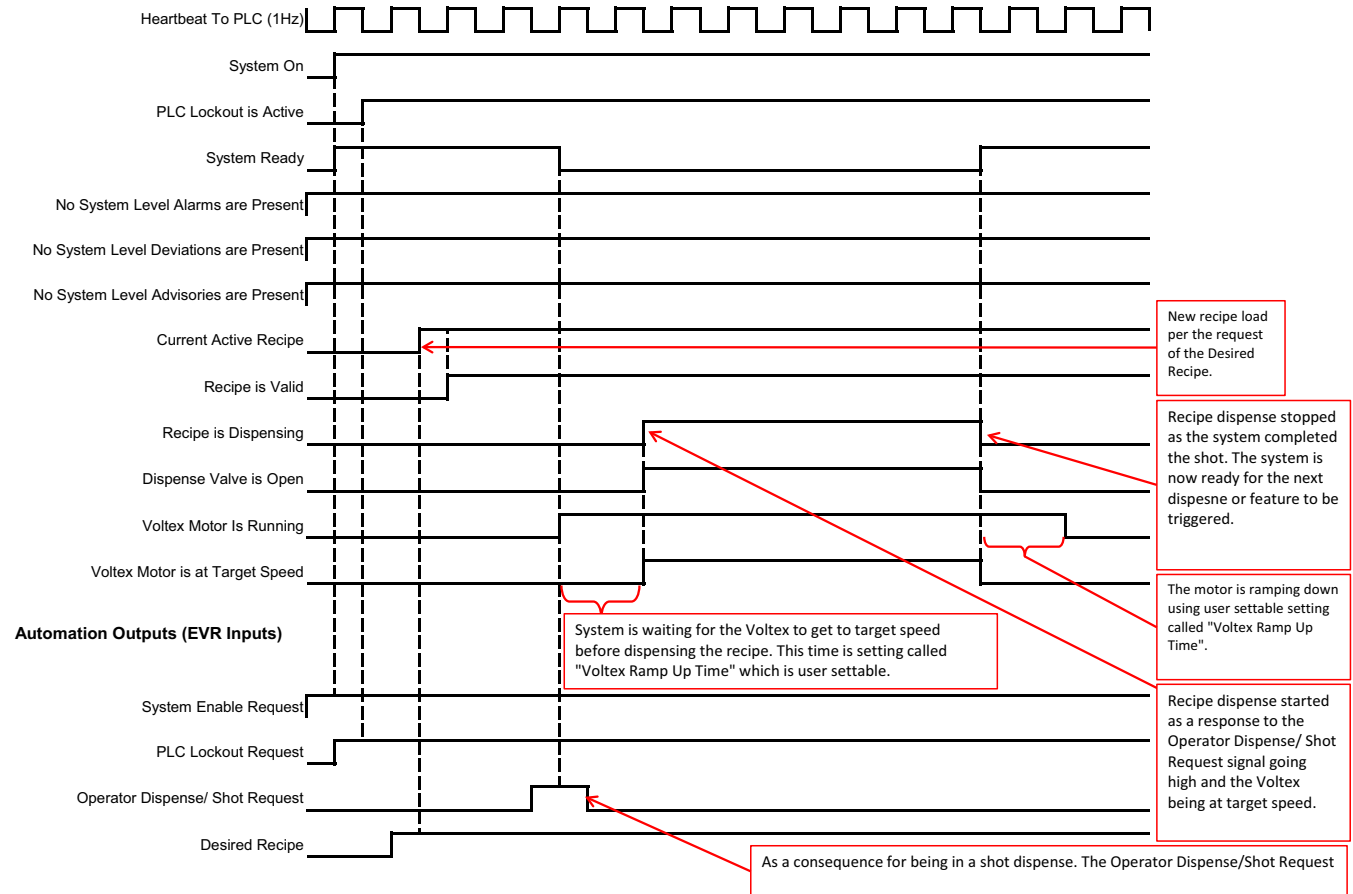

**FIG. 28:**

**EVR Data Exchange Timing**

**Automation Inputs (EVR Outputs)**

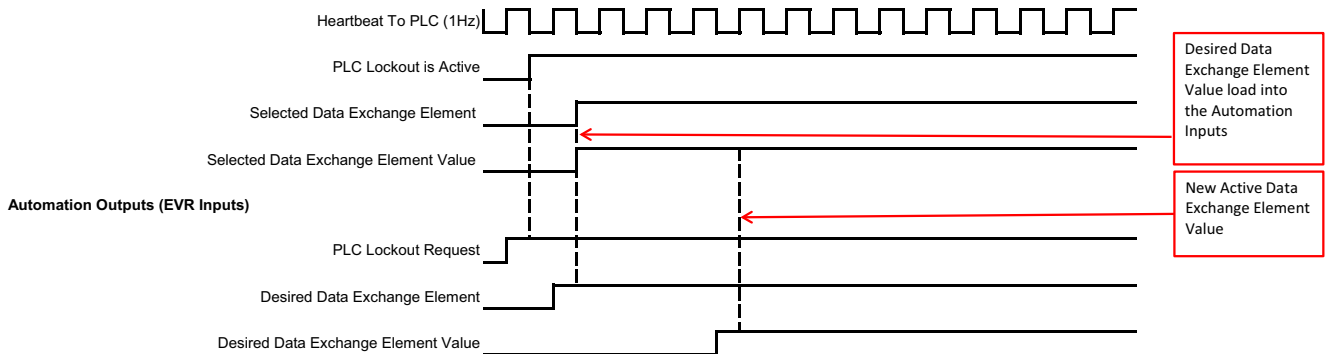

**FIG. 29:**

**Heat Overall CGM Timing**

**Automation Inputs (Heat Outputs)**

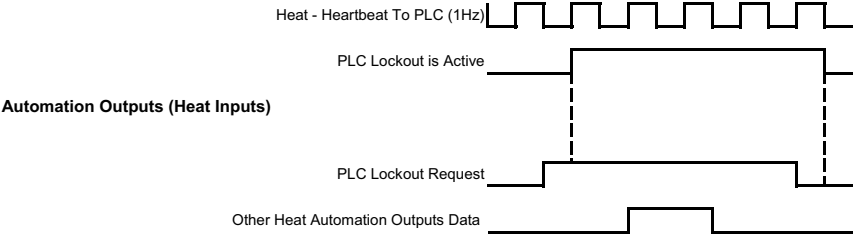

**Notes:**

- Automation Outputs Data needs to have the "PLC Lockout Request" set high for the Automation Output Data to be accepted by the Heat Controller

**FIG. 30:**

**Heat On & Off Request**

**Automation Inputs (Heat Outputs)**

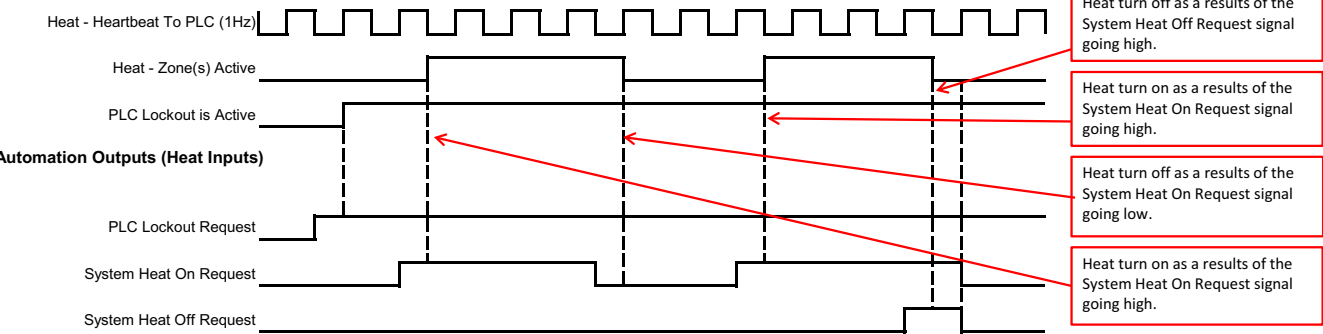

**FIG. 31:**

**Heat Setback Request**

**Automation Inputs (Heat Outputs)**

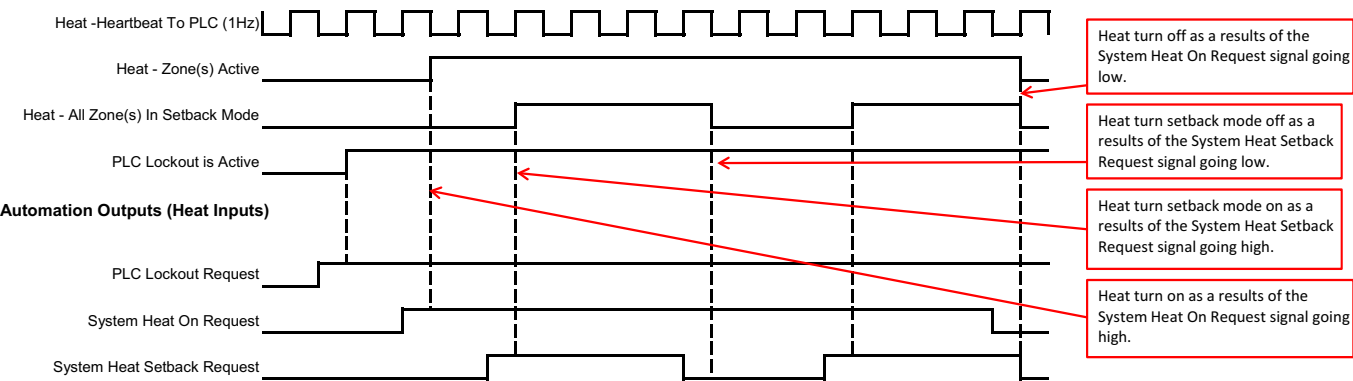
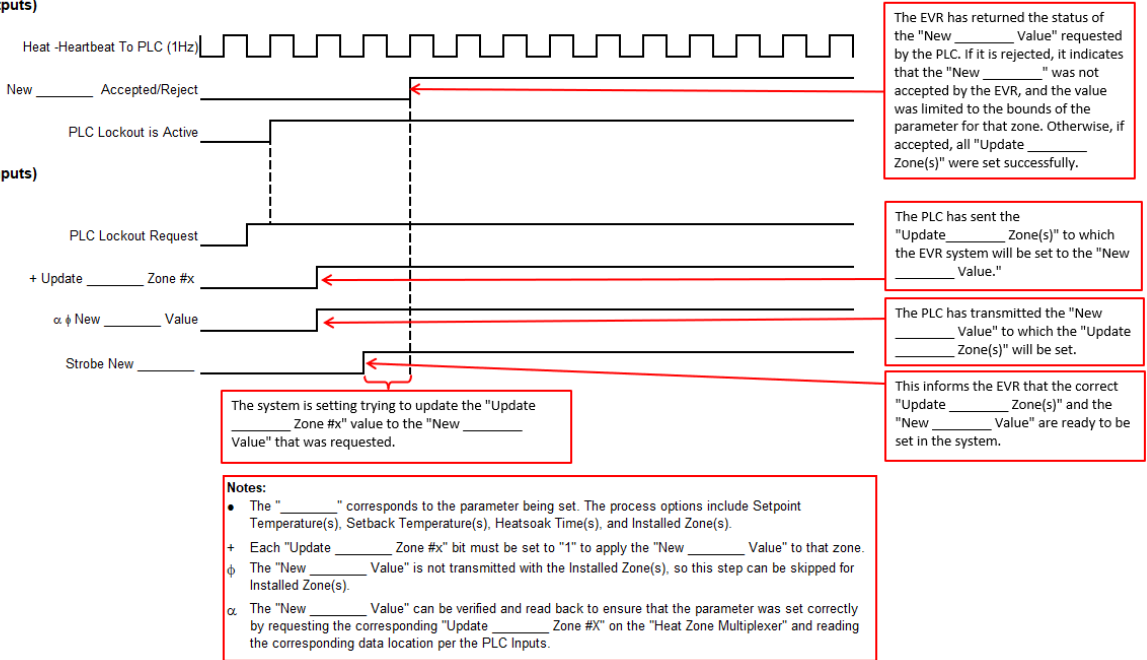

**FIG. 32:**

**Heat Setpoint Changes**

**Automation Inputs (Heat Outputs)**

**Automation Outputs (Heat Inputs)**

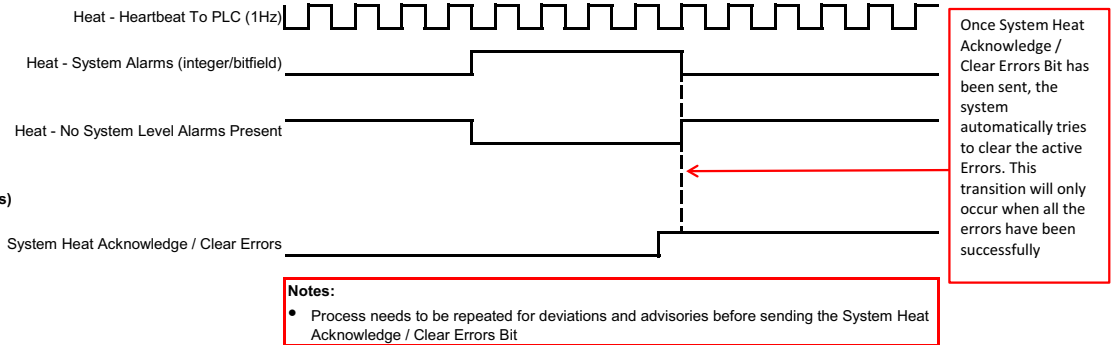

**FIG. 33:**

**Heat System Ack-Clear Errors**

**Automation Inputs (Heat Outputs)**

**Automation Outputs (Heat Inputs)**



**FIG. 34:**

**Heat Zone Ack-Clear Errors**

**Automation Inputs (Heat Outputs)**

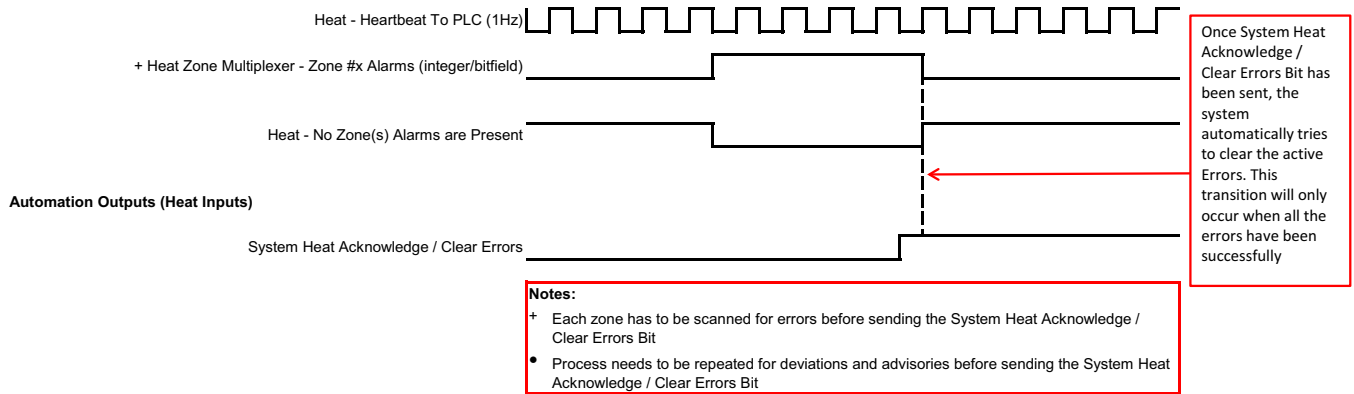

**FIG. 35:**

**Heat Data Exchange Timing**

**Automation Inputs (EVR Outputs)**

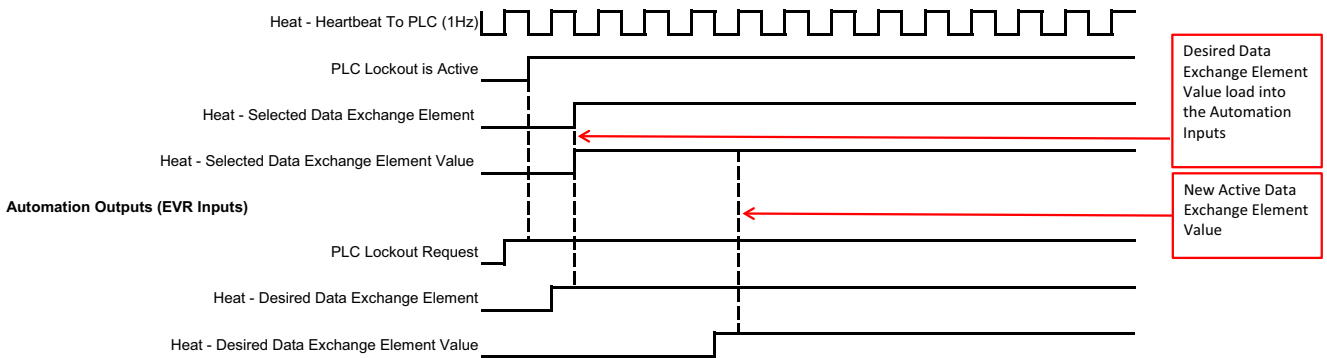

**FIG. 36:**

## Connection Details

### Fieldbus

Connect cables to the fieldbus per fieldbus standards.

### PROFINET

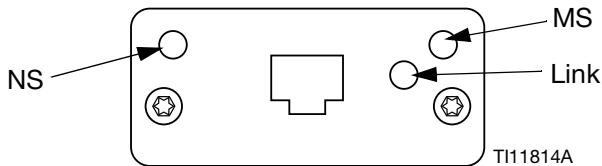

The Ethernet interface operates at 100M bit, full duplex, as required by PROFINET. The Ethernet interface is auto-polarity sensing and auto-crossover capable.

### Network Status (NS)

State	Description	Comments
Off	Off-line	<ul style="list-style-type: none"> <li>No power</li> <li>No connection with IO Controller</li> </ul>
Green	On-line, (RUN)	<ul style="list-style-type: none"> <li>Connection with IO Controller established</li> <li>IO Controller with RUN state</li> </ul>
Flashing Green	On-line, (STOP)	<ul style="list-style-type: none"> <li>Connection with IO Controller established</li> <li>IO Controller in STOP state</li> </ul>

### Module Status (MS)

State	Description	Comments
Off	Not initialized	No power or module in "SETUP" or "NW_INIT" state
Green	Normal operation	Diagnostic event(s) present
Flashing Green	Initialized, diagnostic event(s) present	Used by engineering tools to identify node on network
Red	Exception error	Module in state "EXCEPTION"
Red (1 flash)	Configuration error	Expected Identification differs from Real Identification
Red (2 flashes)	IP Address not set	Set IP address via system monitor or DNS server
Red (3 flashes)	Station Name not set	Set Station Name via system monitor
Red (4 flashes)	Major Internal Error	Cycle system power; replace module

### Link/Activity (Link)

State	Description
Off	No Link, no communication present
Green	Link established, no communication present
Green, flashing	Link established, communication present



### EtherNet/IP

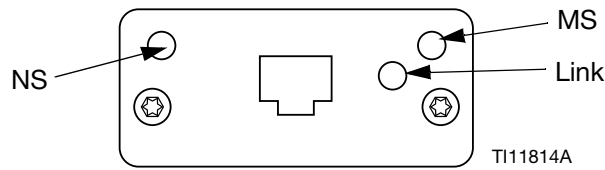

The EtherNet interface operates at 100Mbit, full duplex, as required by PROFINET. The EtherNet interface is auto-polarity sensing and auto-crossover capable.

#### Network Status (NS)

State	Description
Off	No power or no IP address
Green	On-line, one or more connections established (CIP Class 1 or 3)
Flashing Green	On-line, no connections established
Red	Duplicate IP address, FATAL error
Flashing Red	One or more connections timed out (CIP Class 1 or 3)

#### Module Status (MS)

State	Description
Off	No power
Green	Controlled by a Scanner in Run state
Flashing Green	Not configured, or Scanner in Idle state
Red	Major fault (EXCEPTION-state, FATAL error etc.)
Flashing Red	Recoverable fault(s)

#### LINK/Activity (Link)

State	Description
Off	No link, no activity
Green	Link established
Flashing Green	Activity

### DeviceNet

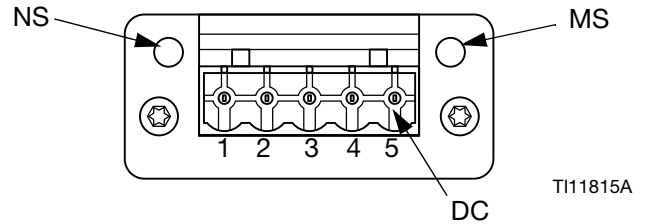

#### Network Status (NS)

State	Description
Off	Not online / No power
Green	On-line, one or more connections are established
Flashing Green (1 Hz)	On-line, no connections established
Red	Critical link failure
Flashing Red (1 Hz)	One or more connections timed-out
Alternating Red/Green	Self test

#### Module Status (MS)

State	Description
Off	No power or not initialized
Green	Initialized
Flashing Green (1 Hz)	Missing or incomplete configuration, device needs commissioning
Red	Unrecoverable Fault(s)
Flashing Red (1 Hz)	Recoverable Fault(s)
Alternating Red/Green	Self test

#### DeviceNet Connector (DC)

Pin	Signal	Description
1	V-	Negative bus supply voltage
2	CAN_L	CAN low bus line
3	SHIELD	Cable shield
4	CAN_H	CAN high bus line
5	V+	Positive bus supply voltage

## PROFIBUS

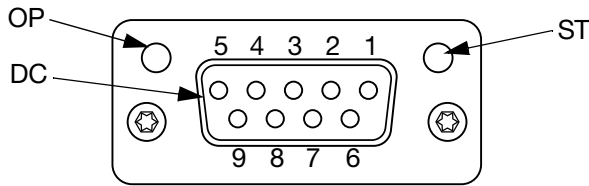

TI11816A

### Operation Mode (OP)

State	Description
Off	Not online / No power
Green	On-line, data exchange
Flashing Green	On-line, clear
Flashing Red (1 flash)	Parameterization error
Flashing Red (2 flashes)	PROFIBUS Configuration error

### Status Mode (ST)

State	Description
Off	No power or not initialized
Green	Initialized
Flashing Green	Initialized, diagnostic event(s) present
Red	Exception error

### PROFIBUS Connector (DC)

Pin	Signal	Description
1	-	-
2	-	-
3	B Line	Positive RxD/TxD, RS485 level
4	RTS	Request to send
5	GND Bus	Ground (isolated)
6	+5V Bus Output	+5V termination power (isolated)
7	-	-
8	A Line	Negative RxD/TxD, RS485 level
9	-	-
Housing	Cable Shield	Internally connected to the Anybus protective earth via cable shield filters according to the PROFIBUS standard.

## Appendix A - Obsolete EVR Maps

With the addition of heat to the EVR, the 19C930 map is now obsolete and will no longer be shipped with EVR systems. However, the EVR can still communicate with a PLC if the original integration was set up using the 19C930 map. See the **Communications Gateway Module (CGM)** section on page 69 for information on new maps that are currently supported.

<b>Gateway Map: EVR Fieldbus Map 19C930</b>	
<b>Comm. Format</b>	<b>Data-SINT</b>
Input Assembly Instance	100
Input Instance Size	48
Output Assembly Instance	150
Output Instance Size	24

### PLC Inputs

<b><i>EVR Fieldbus Map 19C930</i></b>						
<b>Automation Inputs (signal from EVR to PLC)</b>						
<b>Tag ID</b>	<b>Description</b>	<b>Data Type</b>	<b>Minimum Value</b>	<b>Maximum Value</b>	<b>Bit</b>	<b>Byte</b>
1	Heartbeat To PLC	Boolean	0	1	0	0
2	System On	Boolean	0	1	1	
3	PLC Lockout is Active	Boolean	0	1	2	
4	System Ready	Boolean	0	1	3	
5	No Alarms are Present	Boolean	0	1	4	
6	No Deviations are Present	Boolean	0	1	5	
7	No Advisories are Present	Boolean	0	1	6	
8	Recipe is Dispensing	Boolean	0	1	7	
9	Dispense Valve is Opened	Boolean	0	1	0	1
10	System is Purging	Boolean	0	1	1	
11	System is Base Purging	Boolean	0	1	2	
12	System is Depressurizing	Boolean	0	1	3	
13	System is Parking	Boolean	0	1	4	
14	System is Parked	Boolean	0	1	5	
15	Recipe is Valid	Boolean	0	1	6	
16	Gateway Recipe Lockout Active	Boolean	0	1	7	

<b><i>EVR Fieldbus Map 19C930</i></b>						
<b>Automation Inputs (signal from EVR to PLC)</b>						
<b>Tag ID</b>	<b>Description</b>	<b>Data Type</b>	<b>Minimum Value</b>	<b>Maximum Value</b>	<b>Bit</b>	<b>Byte</b>
17	Gel Shot is Dispensing	Boolean	0	1	0	2
18	Gel Shot Countdown Timer is Alarming	Boolean	0	1	1	
19	Red Tank is Filling	Boolean	0	1	2	
20	Red Tank Stand Level $\triangle$ (0-Unknown, 1-Low, 2-Middle, 3-High)	Boolean	0	3	3	
21		Boolean			4	
22	Blue Tank is Filling	Boolean	0	1	5	
23	Blue Tank Stand Level $\star$ (0-Unknown, 1-Low, 2-Middle, 3-High)	Boolean	0	3	6	
24		Boolean			7	
25	System is Recirculating	Boolean	0	1	0	3
26	Voltex Motor is Running	Boolean	0	1	1	
27	EVR Dispense is Waiting for Voltex Motor to Reach Speed	Boolean	0	1	2	
28	Voltex Motor is at Target Speed	Boolean	0	1	3	
29	Voltex Air Injection Valve Opened	Boolean	0	1	4	
30	Reserved Bit1	Boolean	-	-	5	
31	Reserved Bit 2	Boolean	-	-	6	
32	Reserved Bit 3	Boolean	-	-	7	
33	Reserved Word 1	uint16	-	-	0-14	4-5
34	Reserved Word 2	uint16	-	-	0-14	6-7
35	Red Pump Outlet Pressure (XXXX.XX bar)	uint16	0.0	275.79	0-14	8-9
36	Blue Pump Outlet Pressure (XXXX.XX bar)	uint16	0.0	275.79	0-14	10-11
37	Red Pump Inlet Pressure (XXXX.XX bar)	uint16	0.0	275.79	0-14	12-13
38	Blue Pump Inlet Pressure (XXXX.XX bar)	uint16	0.0	275.79	0-14	14-15
39	Combined Pump Flowrate Rate (XXXX.XX cc/sec)	uint16	0.00	69.33	0-14	16-17
40	Current Active Recipe	uint16	0	50	0-14	18-19
41	System Ratio (X.XX : 1.00)	uint16	1.00	5.00	0-14	20-21

<b>EVR Fieldbus Map 19C930</b>						
<b>Automation Inputs (signal from EVR to PLC)</b>						
<b>Tag ID</b>	<b>Description</b>	<b>Data Type</b>	<b>Minimum Value</b>	<b>Maximum Value</b>	<b>Bit</b>	<b>Byte</b>
42	System Ratio Offset (-/+ X.XX)	sint16	0.00	0.25	0-14	22-23
43	Active Recipe Flowrate (XXXX.XX cc/sec)	uint16	0	69.33	0-14	24-25
44	Active Recipe Shot Size (XXXX.XX cc)	uint16	0	327.68	0-14	26-27
45	Active Recipe Type (0 = Shot, 1 = operator)	uint16	0	3	0-14	28-29
46	Active Recipe Shot Calibration (-/+ XXXX.XX cc)	sint16	-99.99	99.99	0-14	30-31
47	Recipe Time Remaining (XX.Xsec)	uint16	0.0	3276.0	0-14	32-33
48	Selected Data Exchange Element	uint16	0	32,767	0-14	34-35
49	Selected Data Exchange Element Value	sint32	See the data exchange for Min and Max Values		0-31	36-39
50	Recipe Requested Shot Amount (XXXX.XXcc)	uint32	0.00	9,999.00	0-31	40-43
51	Recipe Actual Amount (XXXX.XXcc)	uint32	0.00	21,474,836.00	0-31	44-47

**NOTES:**

The data outlined in red is required to create a recipe.

△ Red Tank Stand Level Least Significant Bit (LSB) is bit 3 of byte 2 and the Most Significant Bit (MSB) is bit 4 of byte 2.

☆ Blue Tank Stand Level Least Significant Bit (LSB) is bit 3 of byte 2 and the Most Significant Bit (MSB) is bit 4 of byte 2.

## PLC Outputs

<i>EVR Fieldbus Map 19C930</i>						
<b>Automation Outputs (signal from PLC to EVR)</b>						
<b>Tag ID</b>	<b>Description</b>	<b>Data Type</b>	<b>Minimum Value</b>	<b>Maximum Value</b>	<b>Bit</b>	<b>Byte</b>
1	System Enable Request	Boolean	0	1	0	0
2	PLC Lockout Request *	Boolean	0	1	1	
3	Operator Dispense/ Shot Request (Use discrete signal for proper timing)	Boolean	0	1	2	
4	Cancel Shot	Boolean	0	1	3	
5	Purge Request	Boolean	0	1	4	
6	Base Purge Request	Boolean	0	1	5	
7	Depressurization Request	Boolean	0	1	6	
8	Park Request	Boolean	0	1	7	
9	Acknowledge All Errors Request	Boolean	0	1	0	
10	Gateway Recipe Lockout Request	Boolean	0	1	1	
11	Cancel Gel Shot	Boolean	0	1	2	
12	Red Tank Stand Fill Request	Boolean	0	1	3	
13	Blue Tank Stand Fill Request	Boolean	0	1	4	
14	Recirculation Request	Boolean	0	1	5	
15	Voltex Motor On Request	Boolean	0	1	6	
16	Voltex Air Injection Request	Boolean	0	1	7	
17	Reserved Word 1	uint16	-	-	0-14	2-3
18	Reserved Word 2	uint16	-	-	0-14	4-5
21	Desired Recipe	uint16	1	50	0-14	6-7
19	Desired System Ratio (X.XX : 1.00)	uint16	1.00	5.00	0-14	8-9
20	Desired System Ratio Offset (-/+ X.XX)	sint16	0.00	0.25	0-14	10-11
22	Gateway Recipe Flowrate (XXXX.XX cc/sec)	uint16	0	69.33	0-14	12-13

<b>EVR Fieldbus Map 19C930</b>						
<b>Automation Outputs (signal from PLC to EVR)</b>						
<b>Tag ID</b>	<b>Description</b>	<b>Data Type</b>	<b>Minimum Value</b>	<b>Maximum Value</b>	<b>Bit</b>	<b>Byte</b>
23	Gateway Recipe Shot Size (XXXX.XX cc)	uint16	0	327.68	0-14	14-15
24	Gateway Recipe Type (0 = Shot, 1 = operator)	uint16	0	3	0-14	16-17
25	Desired Data Exchange Element	uint16	0	32,767	0-14	18-19
26	Desired Data Exchange Element Value	sint32	See the data exchange for Min and Max Values		0-31	20-24

**NOTES:**

\* If set, control of the EVR from the ADM will be disabled.

When in operator mode for recipe, the bit must be held high, if dropped low the operator mode will be completed, dispensing will stop and the dispense will be recorded into the shot log.

When in the shot (cc mode) for recipe, a toggle of the button to start the dispense is needed. The shot can be canceled at any time by using the Stop Recipe Request

The data outlined in red is required to create a recipe.

For Data Exchange element data, error code bit data, and timing diagrams, refer to the **Communications Gateway Module (CGM)** section on page 69. This information is utilized the same for both supported and unsupported maps.

# Recycling and Disposal

## End of Product Life

At the end of a product's useful life, recycle it in a responsible manner.

At the end of the product's useful life, dismantle and recycle it in a responsible manner.

- Perform the **Pressure Relief Procedure**.
- Drain and dispose of fluids according to applicable regulations. Refer to the material manufacturer's Safety Data Sheet.
- Remove motors, batteries, circuit boards, LCDs (liquid crystal displays), and other electronic components. Recycle according to applicable regulations.
- Do not dispose of batteries or electronic components with household or commercial waste.



- Deliver remaining product to a recycling facility.



# Schematics

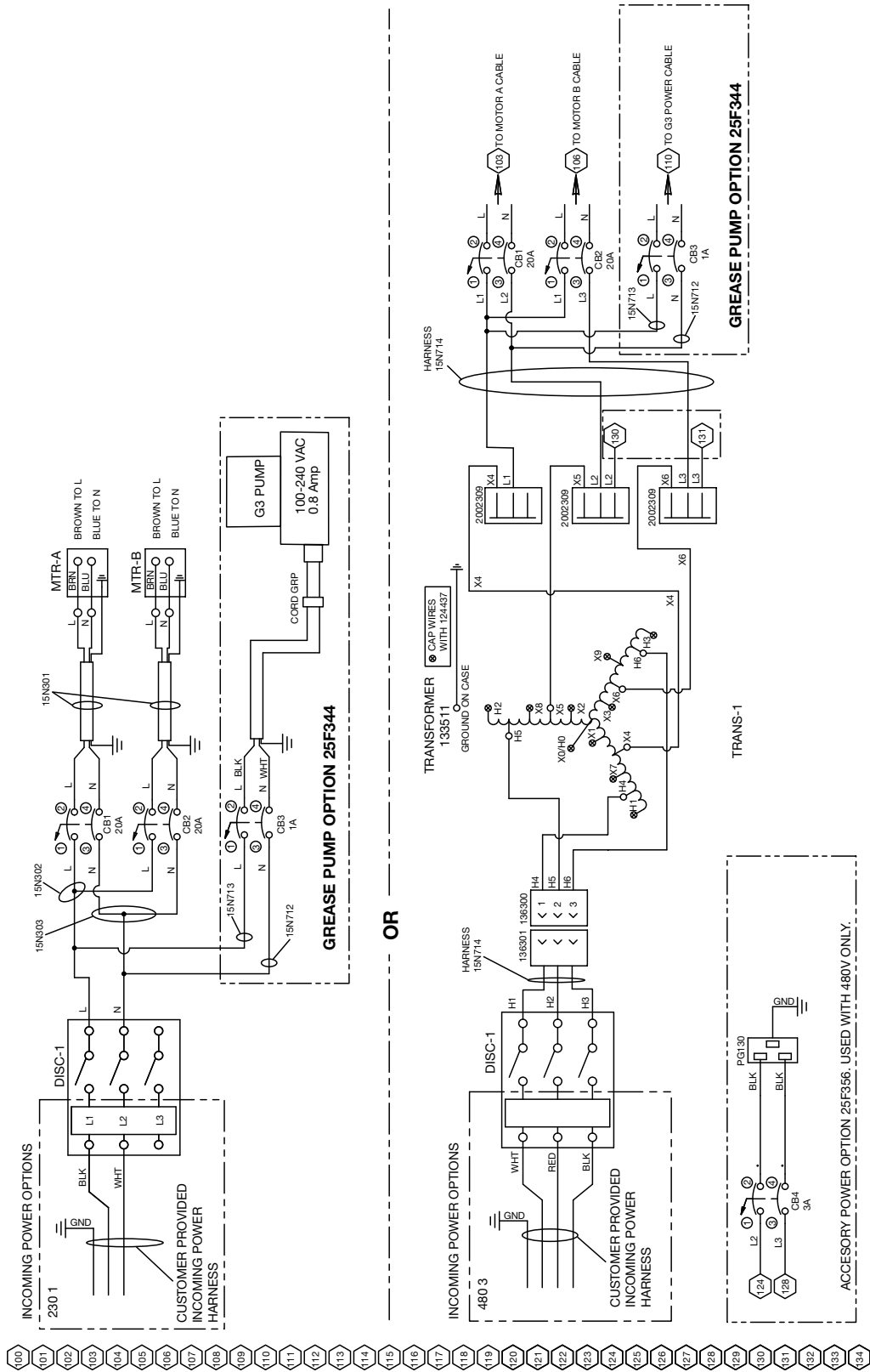



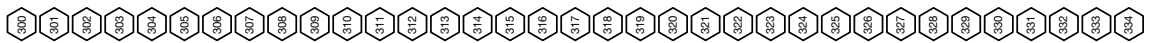
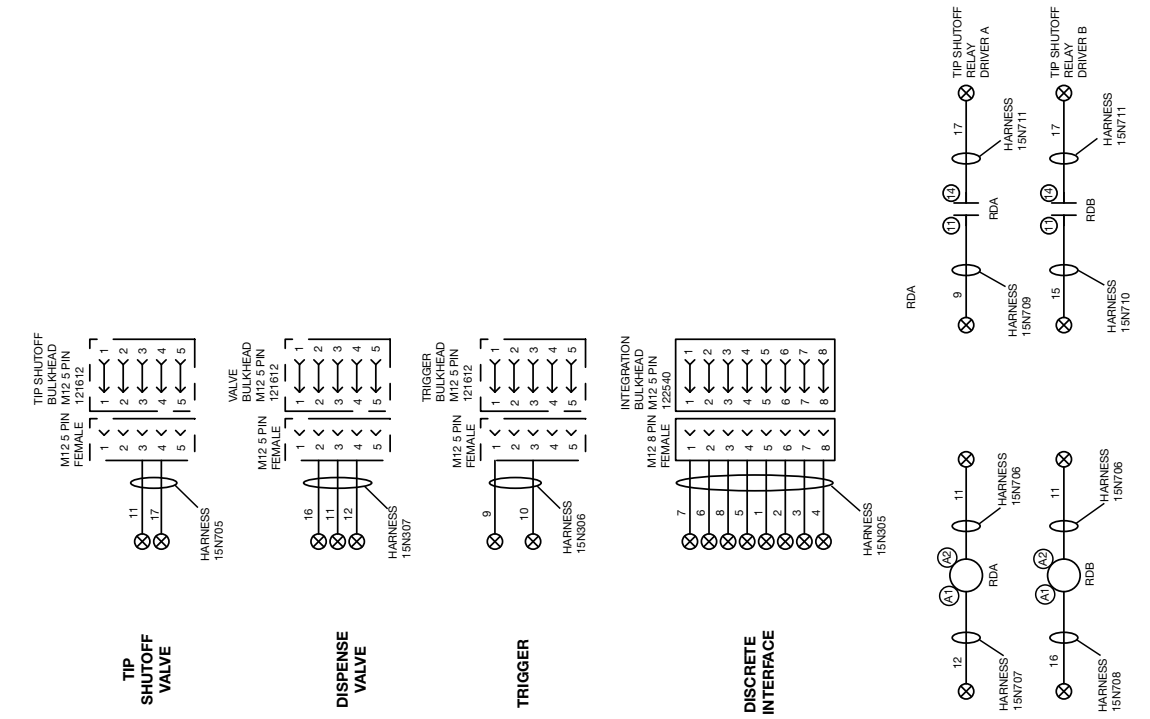
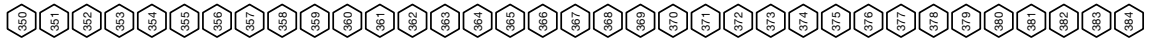
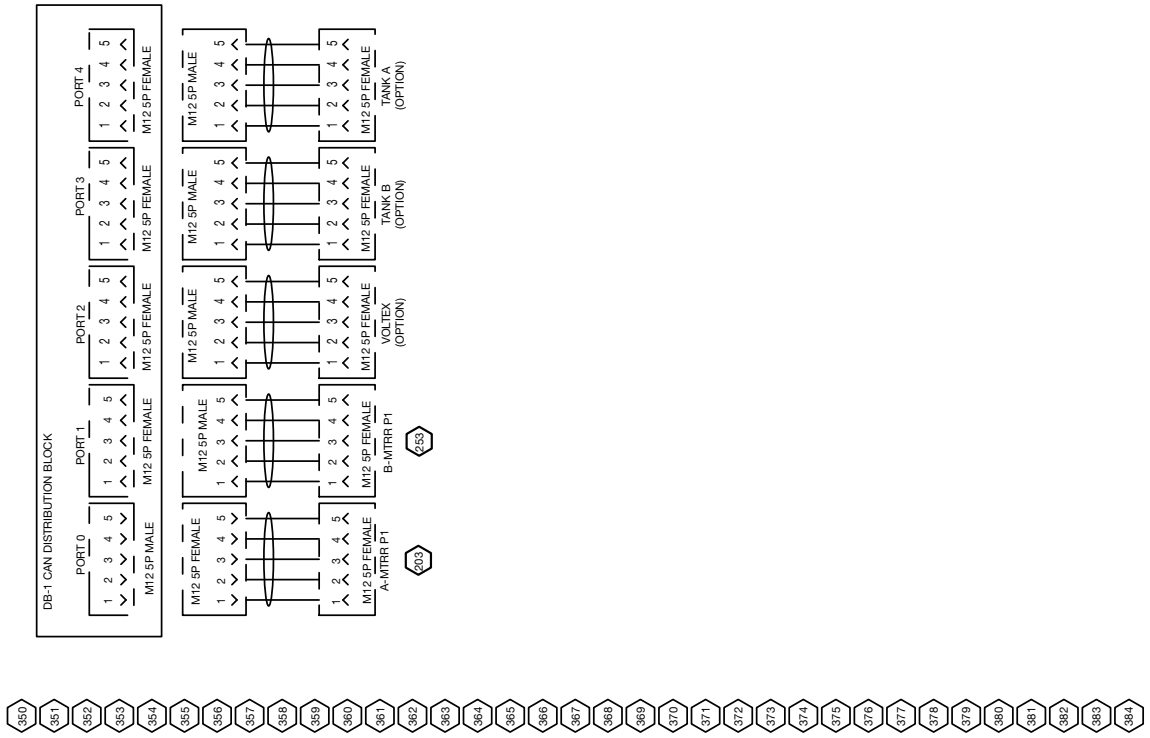

- 400
- 401
- 402
- 403
- 404
- 405
- 406
- 407
- 408
- 409
- 410
- 411
- 412
- 413
- 414
- 415
- 416
- 417
- 418
- 419
- 420
- 421
- 422
- 423
- 424
- 425
- 426
- 427
- 428
- 429
- 430
- 431
- 432
- 433
- 434

**CGM OPTION  
25F323-25F326**

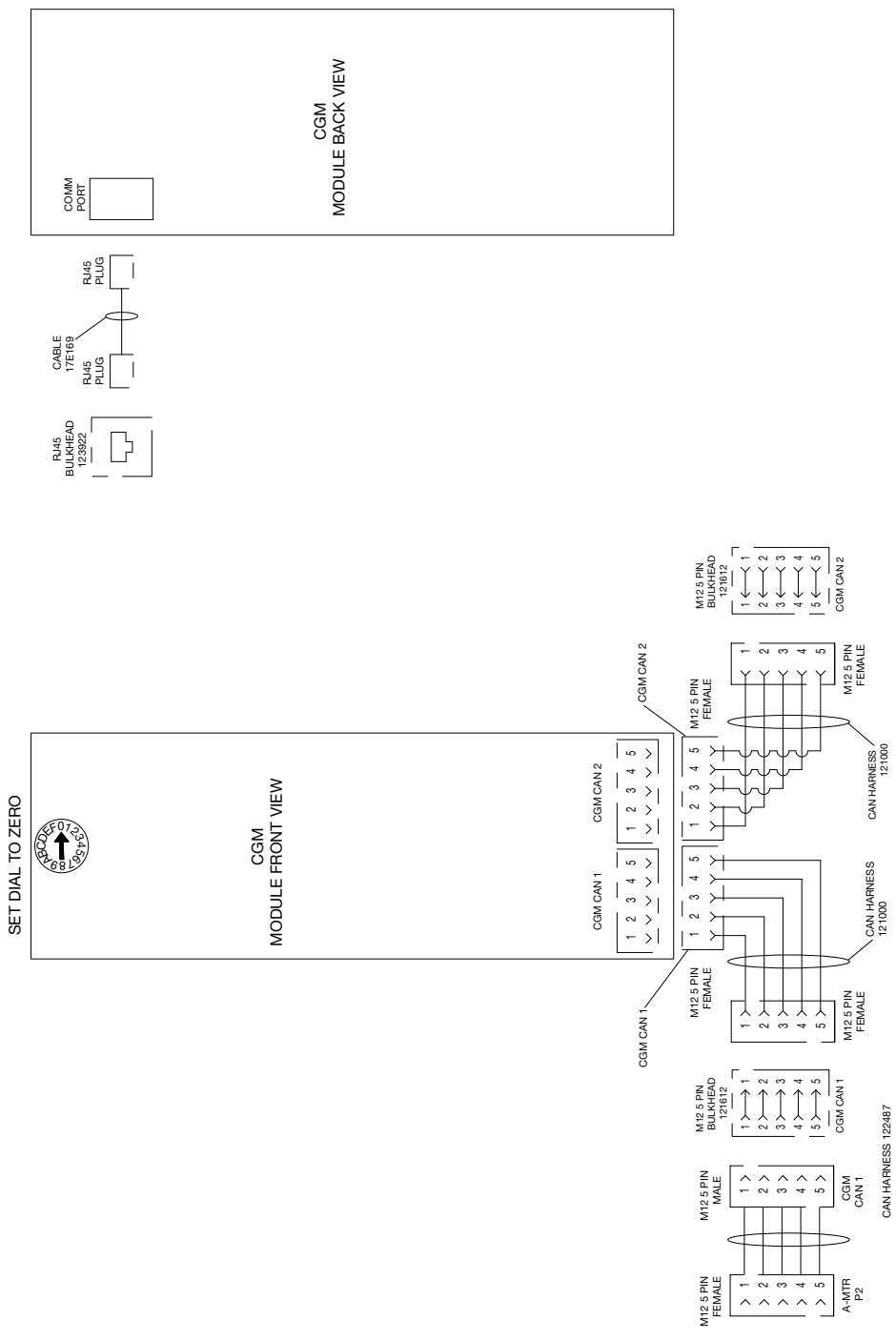

- 500
- 501
- 502
- 503
- 504
- 505
- 506
- 507
- 508
- 509
- 510
- 511
- 512
- 513
- 514
- 515
- 516
- 517
- 518
- 519
- 520
- 521
- 522
- 523
- 524
- 525
- 526
- 527
- 528
- 529
- 530
- 531
- 532
- 533
- 534

OPTION 25F327-25F331  
OR  
25F332-25F334

SET DIAL TO ZERO  
FOR 25F328, 25F331,  
AND 25F332-25F334  
SET DIAL TO ONE  
FOR 25F327 AND 25F330

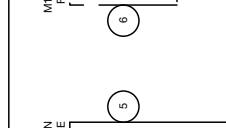
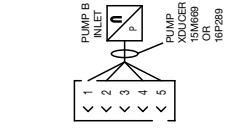
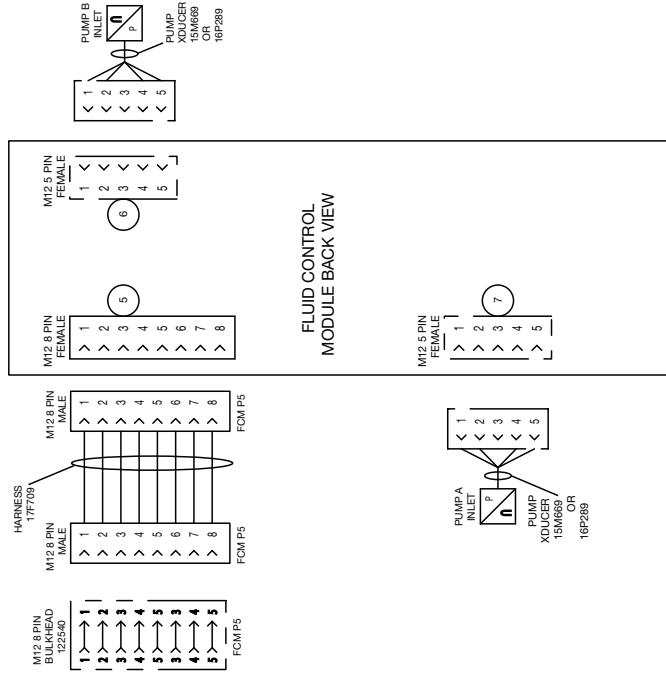
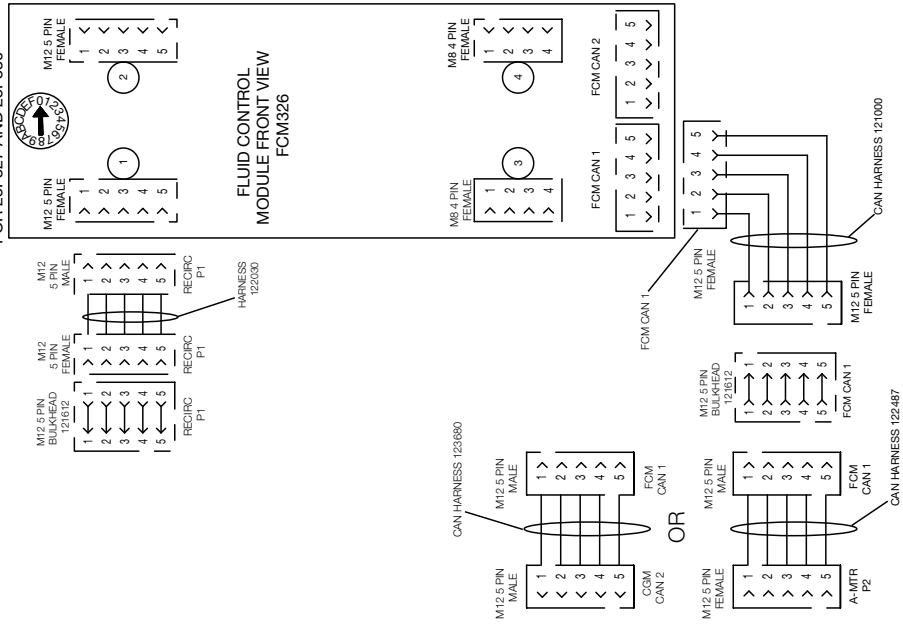

- 600
- 601
- 602
- 603
- 604
- 605
- 606
- 607
- 608
- 609
- 610
- 611
- 612
- 613
- 614
- 615
- 616
- 617
- 618
- 619
- 620
- 621
- 622
- 623
- 624
- 625
- 626
- 627
- 628
- 629
- 630
- 631
- 632
- 633
- 634

### MCM-A CABLES

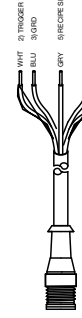

CHA

HARNES NO. 18D286

LOGIC FUNCTION:	TERMINAL NUMBER	WIRE COLOR
1. TRIGGER	10	WHITE
2. TRIGGER	11	WHITE
3. GROUND	8	BLUE
4. SW	5	---
5. RECPE SELECT	5	GREY
6. SPARE	---	---
7. SPARE	---	---
8. SPARE	---	---
9. SPARE	---	---
10. SPARE	---	---
11. SPARE	---	---
12. SPARE	---	---
13. SPARE	---	---
14. SPARE	---	---
15. SPARE	---	---
16. SPARE	---	---
17. SPARE	---	---
18. SPARE	---	---
19. SPARE	---	---
20. SPARE	---	---
21. SPARE	---	---
22. SPARE	---	---
23. SPARE	---	---
24. SPARE	---	---
25. SPARE	---	---
26. SPARE	---	---
27. SPARE	---	---
28. SPARE	---	---
29. SPARE	---	---
30. SPARE	---	---

### MCM-B CABLES

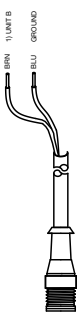

CHB

HARNES NO. 18D288

LOGIC FUNCTION:	TERMINAL NUMBER	WIRE COLOR
1. TRIGGER	15	BROWN
2. TRIGGER	8	---
3. GROUND	8	---
4. SW	---	---
5. RECPE SELECT	---	---
6. SPARE	---	---
7. SPARE	---	---
8. SPARE	---	---
9. SPARE	---	---
10. SPARE	---	---
11. SPARE	---	---
12. SPARE	---	---
13. SPARE	---	---
14. SPARE	---	---
15. SPARE	---	---
16. SPARE	---	---
17. SPARE	---	---
18. SPARE	---	---
19. SPARE	---	---
20. SPARE	---	---
21. SPARE	---	---
22. SPARE	---	---
23. SPARE	---	---
24. SPARE	---	---
25. SPARE	---	---
26. SPARE	---	---
27. SPARE	---	---
28. SPARE	---	---
29. SPARE	---	---
30. SPARE	---	---

### BULKHEAD CABLES



INT

HARNES NO. 15N305

LOGIC FUNCTION:	TERMINAL NUMBER	WIRE COLOR
1. SYSTEM READY	1	BRN
2. ALARM PRESENT	2	WHT
3. GROUND	3	BLU
4. RECPE SELECT	4	BLK
5. RECPE SELECT	5	BLK
6. RECPE SELECT	6	BLK
7. RECPE SELECT	7	BLK
8. RECPE SELECT	8	BLK
9. RECPE SELECT	9	BLK
10. RECPE SELECT	10	BLK
11. RECPE SELECT	11	BLK
12. RECPE SELECT	12	BLK
13. RECPE SELECT	13	BLK
14. RECPE SELECT	14	BLK
15. RECPE SELECT	15	BLK
16. RECPE SELECT	16	BLK
17. RECPE SELECT	17	BLK
18. RECPE SELECT	18	BLK
19. RECPE SELECT	19	BLK
20. RECPE SELECT	20	BLK
21. RECPE SELECT	21	BLK
22. RECPE SELECT	22	BLK
23. RECPE SELECT	23	BLK
24. RECPE SELECT	24	BLK
25. RECPE SELECT	25	BLK
26. RECPE SELECT	26	BLK
27. RECPE SELECT	27	BLK
28. RECPE SELECT	28	BLK
29. RECPE SELECT	29	BLK
30. RECPE SELECT	30	BLK

### BULKHEAD CABLE

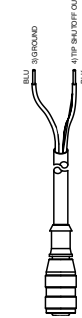

THP

HARNES NO. 15N705

LOGIC FUNCTION:	TERMINAL NUMBER	WIRE COLOR
1. GROUND	1	BLU
2. GROUND	2	BLU
3. GROUND	3	BLU
4. TRIP-OUT RELAY DRIVER B (RDB)	11	BLU
5. TRIP-OUT RELAY DRIVER B (RDB)	17	BLK
6. TRIP-OUT RELAY DRIVER B (RDB)	17	GRY

GEOMETRY TYPICAL FOR ALL HARNESSES LISTED BELOW

HARNES NO. 19N706 QTY. 2

LOGIC FUNCTION:	TERMINAL NUMBER	WIRE COLOR
1. GROUND RELAY DRIVER B (RDB)	11	BLU
2. GROUND RELAY DRIVER B (RDB)	11	WHT/BLU

HARNES NO. 19N707 QTY. 1

LOGIC FUNCTION:	TERMINAL NUMBER	WIRE COLOR
1. TRIP-OUT RELAY DRIVER B (RDB)	11	BLU

HARNES NO. 19N708 QTY. 1

LOGIC FUNCTION:	TERMINAL NUMBER	WIRE COLOR
1. TRIP-OUT RELAY DRIVER B (RDB)	11	BLU

### ADM CABLE

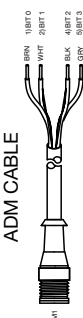

ADM

HARNES NO. 18D289

LOGIC FUNCTION:	TERMINAL NUMBER	WIRE COLOR
1. RECPE SELECT BT 0	1	BRN
2. RECPE SELECT BT 1	2	WHT
3. GROUND	---	---
4. RECPE SELECT BT 2	3	BLK
5. RECPE SELECT BT 3	4	GRY
6. RECPE SELECT BT 4	5	GRY

### BULKHEAD CABLES

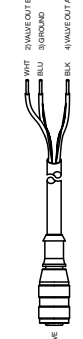

VALVE

HARNES NO. 15N307

LOGIC FUNCTION:	TERMINAL NUMBER	WIRE COLOR
1. VALVE OUT B	9	BRN
2. VALVE OUT B	9	WHT
3. GROUND	---	---
4. VALVE OUT A	10	BLU
5. VALVE OUT A	10	BLK
6. VALVE OUT A	---	---
7. VALVE OUT A	---	---
8. VALVE OUT A	---	---
9. VALVE OUT A	---	---
10. VALVE OUT A	---	---
11. VALVE OUT A	---	---
12. VALVE OUT A	---	---
13. VALVE OUT A	---	---
14. VALVE OUT A	---	---
15. VALVE OUT A	---	---
16. VALVE OUT A	---	---
17. VALVE OUT A	---	---
18. VALVE OUT A	---	---
19. VALVE OUT A	---	---
20. VALVE OUT A	---	---
21. VALVE OUT A	---	---
22. VALVE OUT A	---	---
23. VALVE OUT A	---	---
24. VALVE OUT A	---	---
25. VALVE OUT A	---	---
26. VALVE OUT A	---	---
27. VALVE OUT A	---	---
28. VALVE OUT A	---	---
29. VALVE OUT A	---	---
30. VALVE OUT A	---	---

# Dimensions

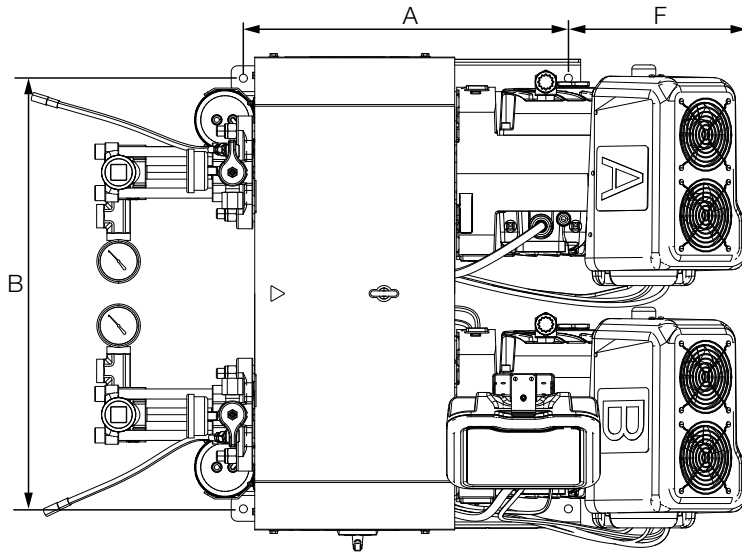

## 240VAC Single Phase EVR

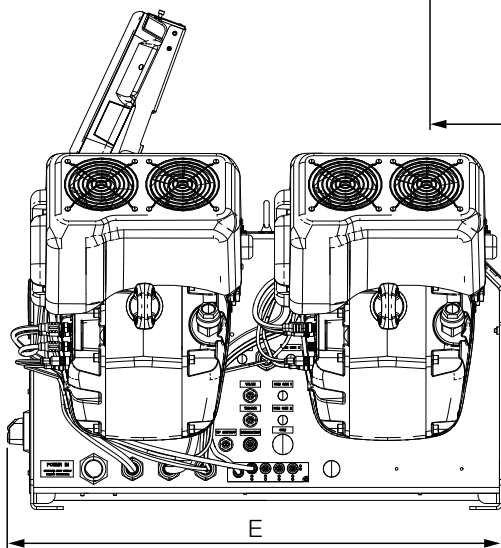
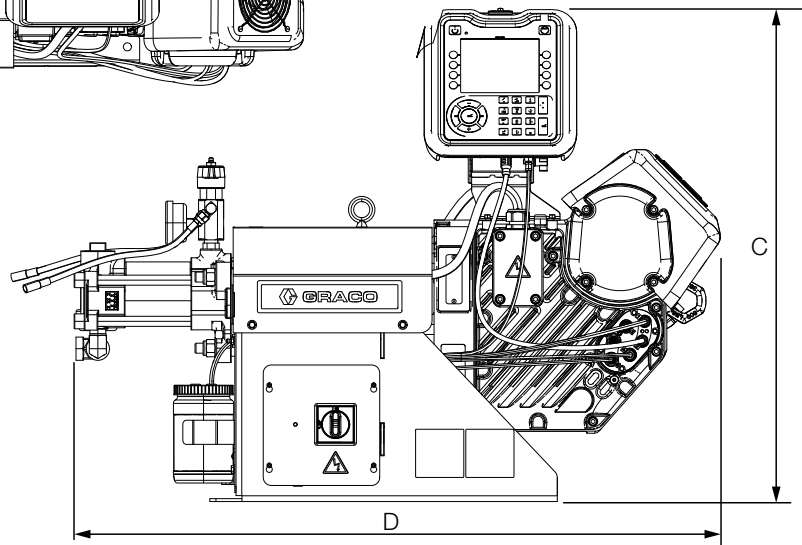

### Dimensions

A	Machine Mounting Holes	20.1 in. (51 cm)
	For 3/8 in. (10mm) Mounting Fasteners	
B	Machine Mounting Holes	26.7 in. (68 cm)
C	Total Machine Height	31 in. (79 cm)
D	Total Machine Length	40.3 in. (102 cm)
E	Total Machine Width	30.5 in. (77 cm)
F	Mounting Hole Offset	11 in. (28 cm)

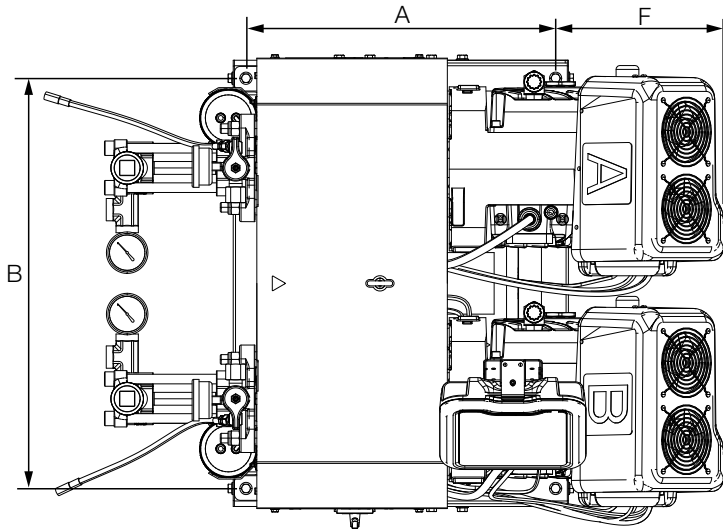

## 480VAC Three Phase EVR

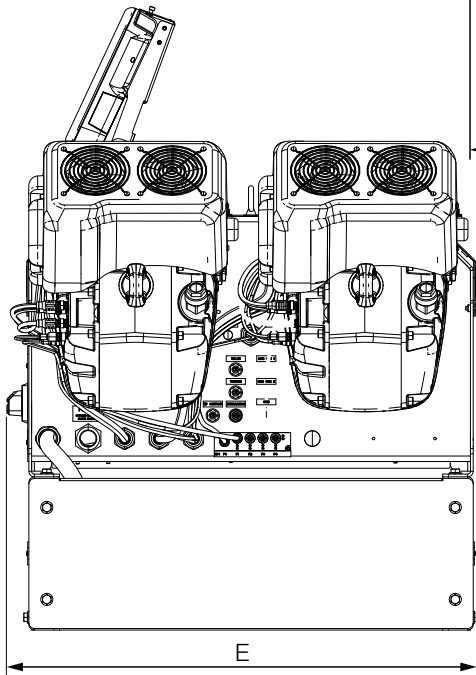
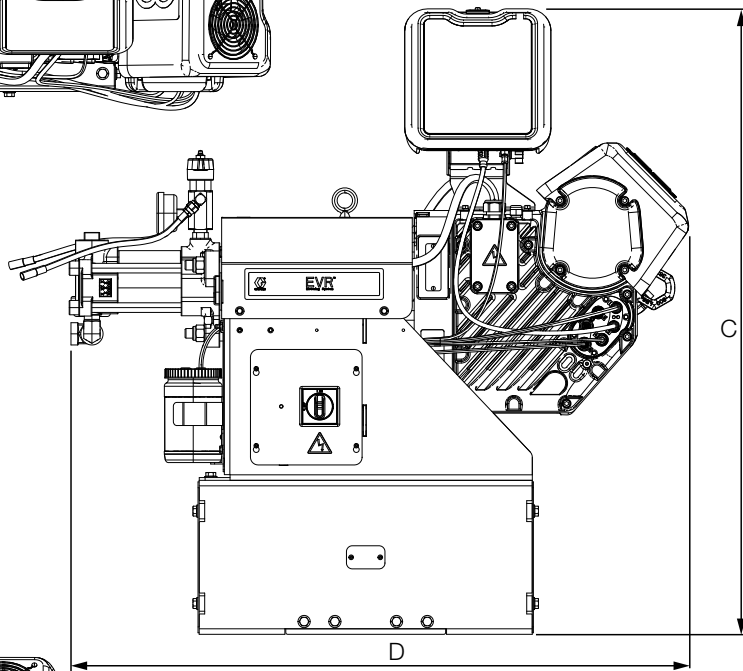

### Dimensions

A	Machine Mounting Holes	20.1 in. (51 cm)
	For 3/8 in. (10mm) Mounting Fasteners	
B	Machine Mounting Holes	26.7 in. (68 cm)
C	Total Machine Height	41 in. (79 cm)
D	Total Machine Length	40.3 in. (102 cm)
E	Total Machine Width	30.5 in. (77 cm)
F	Mounting Hole Offset	11 in. (28 cm)



# Technical Specifications

<b>EVR</b>		
	<b>US</b>	<b>Metric</b>
Maximum fluid working pressure ‡	3500 psi	24 MPa, 241 bar
Maximum fluid temperature	120°F	50°C
Fluid circulation ports	1/4 NPS(m)	
Line voltage rating	200-240V, 1ph, 41A, 50/60 Hz	
	480V, 3ph, 18A, 50/60Hz	
Wetted parts	Stainless steel, zinc-plated carbon steel, brass, tungsten carbide, chrome, fluoroelastomer, PTFE, ultra-high molecular weight polyethylene, silicon nitride	
Weight at 240V	425 lbs	193 kg
Weight at 480V	680lbs	308kg
<b>Fluid inlet pressure at inlet fitting</b>		
Pump Inlet	70 - 2000 psi	0.48 - 13.8 MPa, 4.8 - 138 bar
<b>Fluid Inlets</b>		
Component A	3/4 npt(f)	
Component B	3/4 npt(f)	
<b>Fluid Outlets on Manifolds</b>		
Component A	1/2 npt(f)	
Component B	1/2 npt(f)	
<b>NOTES</b>		
<p>‡ The maximum fluid working pressure for the base machine without hoses is 3500 psi (24.1 MPa, 241 bar). If hoses, valves or accessories rated at less than 3500 psi are installed, the system maximum fluid working pressure becomes the rating of the hoses. The minimum pressure rating for hoses is 2000 psi. Do not install hoses with a pressure rating lower than 2000 psi.</p> <p>All other brand names or marks are used for identification purposes and are trademarks of their respective owners.</p>		

## California Proposition 65

### CALIFORNIA RESIDENTS

 **WARNING:** Cancer and reproductive harm – [www.P65warnings.ca.gov](http://www.P65warnings.ca.gov).

# Graco Standard Warranty

Graco warrants all equipment referenced in this document which is manufactured by Graco and bearing its name to be free from defects in material and workmanship on the date of sale to the original purchaser for use. With the exception of any special, extended, or limited warranty published by Graco, Graco will, for a period of twelve months from the date of sale, repair or replace any part of the equipment determined by Graco to be defective. This warranty applies only when the equipment is installed, operated and maintained in accordance with Graco's written recommendations.

This warranty does not cover, and Graco shall not be liable for general wear and tear, or any malfunction, damage or wear caused by faulty installation, misapplication, abrasion, corrosion, inadequate or improper maintenance, negligence, accident, tampering, or substitution of non-Graco component parts. Nor shall Graco be liable for malfunction, damage or wear caused by the incompatibility of Graco equipment with structures, accessories, equipment or materials not supplied by Graco, or the improper design, manufacture, installation, operation or maintenance of structures, accessories, equipment or materials not supplied by Graco.

This warranty is conditioned upon the prepaid return of the equipment claimed to be defective to an authorized Graco distributor for verification of the claimed defect. If the claimed defect is verified, Graco will repair or replace free of charge any defective parts. The equipment will be returned to the original purchaser transportation prepaid. If inspection of the equipment does not disclose any defect in material or workmanship, repairs will be made at a reasonable charge, which charges may include the costs of parts, labor, and transportation.

**THIS WARRANTY IS EXCLUSIVE, AND IS IN LIEU OF ANY OTHER WARRANTIES, EXPRESS OR IMPLIED, INCLUDING BUT NOT LIMITED TO WARRANTY OF MERCHANTABILITY OR WARRANTY OF FITNESS FOR A PARTICULAR PURPOSE.**

Graco's sole obligation and buyer's sole remedy for any breach of warranty shall be as set forth above. The buyer agrees that no other remedy (including, but not limited to, incidental or consequential damages for lost profits, lost sales, injury to person or property, or any other incidental or consequential loss) shall be available. Any action for breach of warranty must be brought within two (2) years of the date of sale.

**GRACO MAKES NO WARRANTY, AND DISCLAIMS ALL IMPLIED WARRANTIES OF MERCHANTABILITY AND FITNESS FOR A PARTICULAR PURPOSE, IN CONNECTION WITH ACCESSORIES, EQUIPMENT, MATERIALS OR COMPONENTS SOLD BUT NOT MANUFACTURED BY GRACO.** These items sold, but not manufactured by Graco (such as electric motors, switches, hose, etc.), are subject to the warranty, if any, of their manufacturer. Graco will provide purchaser with reasonable assistance in making any claim for breach of these warranties.

In no event will Graco be liable for indirect, incidental, special or consequential damages resulting from Graco supplying equipment hereunder, or the furnishing, performance, or use of any products or other goods sold hereto, whether due to a breach of contract, breach of warranty, the negligence of Graco, or otherwise.

## **FOR GRACO CANADA CUSTOMERS**

The Parties acknowledge that they have required that the present document, as well as all documents, notices and legal proceedings entered into, given or instituted pursuant hereto or relating directly or indirectly hereto, be drawn up in English. Les parties reconnaissent avoir convenu que la rédaction du présente document sera en Anglais, ainsi que tous documents, avis et procédures judiciaires exécutés, donnés ou intentés, à la suite de ou en rapport, directement ou indirectement, avec les procédures concernées.

# Graco Information

## Sealant and Adhesive Dispensing Equipment

For the latest information about Graco products, visit [www.graco.com](http://www.graco.com).

For patent information, see [www.graco.com/patents](http://www.graco.com/patents).

**TO PLACE AN ORDER**, contact your Graco distributor, go to [www.graco.com](http://www.graco.com), or call to identify the nearest distributor.

**Toll Free Phone Number:** 1-800-328-0211

*All written and visual data contained in this document reflects the latest product information available at the time of publication. Graco reserves the right to make changes at any time without notice.*

Original instructions. This manual contains English. MM 3A8565

**Graco Headquarters:** Minneapolis

**International Offices:** Belgium, China, Japan, Korea

**GRACO INC. AND SUBSIDIARIES • P.O. BOX 1441 • MINNEAPOLIS MN 55440-1441 • USA**  
**Copyright 2021, Graco Inc. All Graco manufacturing locations are registered to ISO 9001.**

[www.graco.com](http://www.graco.com)  
Revision E, June 2024