

# Check-Mate® Elite Series Displacement Pumps

3A8564D

EN

*Pump with priming piston and Elite Series rod and cylinder. For professional use only.*

## Model L100CE (Series B), L200CE(Series B), L250CE and L500CE

See page 3 for model information. See page 43 for Maximum Working Pressure.



### Important Safety Instructions

Read all warnings and instructions in this manual before using the equipment.  
Save these instructions.

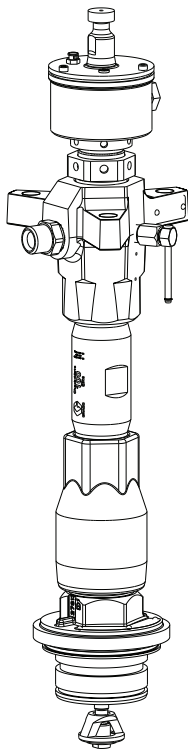

Model L100CE  
Series B

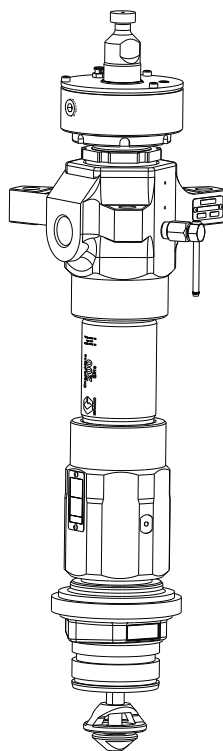

Model L200CE  
Series B

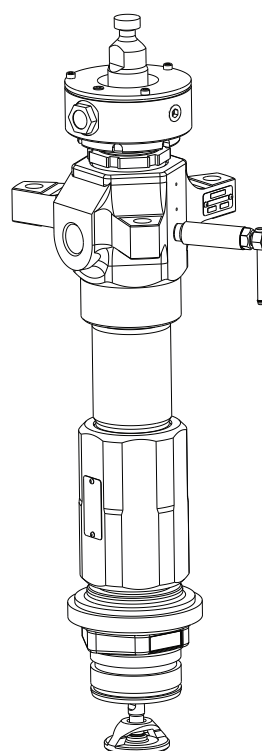

Model L250CE

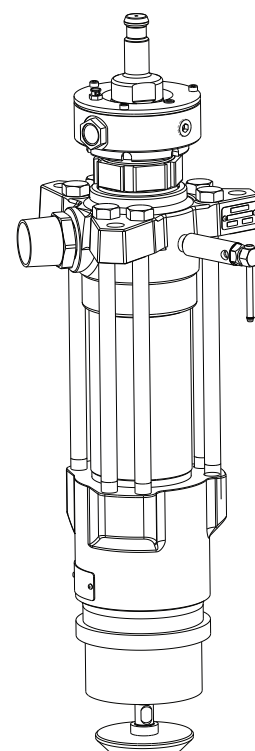

Model L500CE

# Contents

- Related Manuals** ..... 2
- Models** ..... 3
- Warnings** ..... 4
- Important Isocyanate (ISO) Information** ..... 7
  - Moisture Sensitivity of Isocyanates ..... 7
  - Changing Materials ..... 7
- Component Identification** ..... 8
- Operation** ..... 9
  - Pressure Relief Procedure ..... 9
- Recycling and Disposal** ..... 10
  - End of Product Life ..... 10
- Troubleshooting** ..... 11
- Repair** ..... 13
  - Disassembly and Reassembly of Throat Packings  
and Cartridge ..... 13
  - Disassembly ..... 14
  - Reassembly ..... 19
- Parts** ..... 28
  - 100 cc Displacement Pump L100CE ..... 28
  - 200 cc Displacement Pump L200CE ..... 32
  - 250 cc Displacement Pump L250CE ..... 36
  - 500 cc Displacement Pump L500CE ..... 39
- Dimensions** ..... 42
- Technical Specifications** ..... 43
- Graco Standard Warranty** ..... 44

# Related Manuals

English Manuals	Description
312376	Check-Mate® Pump Packages Instruction-Parts
313526	Supply Units Operation
313527	Supply Units Repair-Parts
313528	Tandem Supply Units Operation
313529	Tandem Supply Units Repair-Parts
3A6331	E-Flo® SP Supply Systems
333586	E-Flo® IQ Dispense Systems

# Models

Check your displacement pump’s identification plate (ID) for the 6-digit part number of your displacement pump. Use the following matrix to define the construction of your displacement pump, based on the six digits. For example, displacement pump Part No. **L100CE** represents the displacement pump (**L**), output volume in cc per cycle (**100**), carbon steel construction (**C**), and Elite series (**E**).

To order replacement parts, see **Parts** section starting on page 28. The digits in the matrix do not correspond to the Ref. Nos. in the **Parts** drawings and lists.

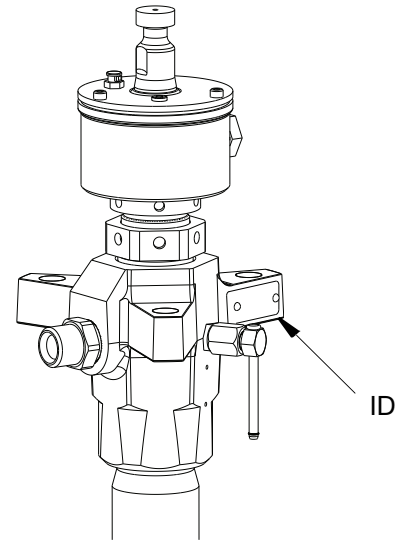





FIG. 1

<b>L</b>	<b>100</b>	<b>C</b>	<b>E</b>		
First Digit	Second, Third, and Fourth Digits	Fifth Digit	Sixth Digit		
	Displacement Pump Volume per cycle (cc)		Material		
			Coatings, Packings		
<b>L</b> (Displacement pump)	100	<b>C</b>	Carbon Steel	<b>E</b>	Elite
	200				
	250				
	500				

# Warnings

The following warnings are for the setup, use, grounding, maintenance, and repair of this equipment. The exclamation point symbol alerts you to a general warning and the hazard symbols refer to procedure-specific risks. When these symbols appear in the body of this manual or on warning labels, refer back to these Warnings. Product-specific hazard symbols and warnings not covered in this section may appear throughout the body of this manual where applicable.

 <h1 style="margin: 0;">WARNING</h1>	
	<p><b>SKIN INJECTION HAZARD</b></p> <p>High-pressure fluid from dispensing device, hose leaks, or ruptured components will pierce skin. This may look like just a cut, but it is a serious injury that can result in amputation. <b>Get immediate surgical treatment.</b></p> <ul style="list-style-type: none"> <li>• Do not point dispensing device at anyone or at any part of the body.</li> <li>• Do not put your hand over the spray tip.</li> <li>• Do not stop or deflect leaks with your hand, body, glove, or rag.</li> <li>• Engage trigger lock when not spraying.</li> <li>• Follow the <b>Pressure Relief Procedure</b> when you stop dispensing and before cleaning, checking, or servicing equipment.</li> <li>• Tighten all fluid connections before operating the equipment.</li> <li>• Check hoses and couplings daily. Replace worn or damaged parts immediately.</li> </ul>
	<p><b>MOVING PARTS HAZARD</b></p> <p>Moving parts can pinch, cut or amputate fingers and other body parts.</p> <ul style="list-style-type: none"> <li>• Keep clear of moving parts.</li> <li>• Do not operate equipment with protective guards or covers removed.</li> <li>• Equipment can start without warning. Before checking, moving, or servicing equipment, follow the <b>Pressure Relief Procedure</b> and disconnect all power sources.</li> </ul>

# WARNING



## FIRE AND EXPLOSION HAZARD

Flammable fumes, such as solvent and paint fumes, in **work area** can ignite or explode. Paint or solvent flowing through the equipment can cause static sparking. To help prevent fire and explosion:



- Use equipment only in well-ventilated area.
- Eliminate all ignition sources; such as pilot lights, cigarettes, portable electric lamps, and plastic drop cloths (potential static sparking).
- Ground all equipment in the work area.
- Never spray or flush solvent at high pressure.
- Keep work area free of debris, including solvent, rags and gasoline.
- Do not plug or unplug power cords, or turn power or light switches on or off when flammable fumes are present.
- Use only grounded hoses.
- Hold gun firmly to side of grounded pail when triggering into pail. Do not use pail liners unless they are anti-static or conductive.
- **Stop operation immediately** if static sparking occurs or you feel a shock. Do not use equipment until you identify and correct the problem.
- Keep a working fire extinguisher in the work area.



## EQUIPMENT MISUSE HAZARD

Misuse can cause death or serious injury.



- Do not operate the unit when fatigued or under the influence of drugs or alcohol.
- Do not exceed the maximum working pressure or temperature rating of the lowest rated system component. See **Technical Specifications** in all equipment manuals.
- Use fluids and solvents that are compatible with equipment wetted parts. See **Technical Specifications** in all equipment manuals. Read fluid and solvent manufacturer's warnings. For complete information about your material, request Safety Data Sheets (SDSs) from distributor or retailer.
- Do not leave the work area while equipment is energized or under pressure.
- Turn off all equipment and follow the **Pressure Relief Procedure** when equipment is not in use.
- Check equipment daily. Repair or replace worn or damaged parts immediately with genuine manufacturer's replacement parts only.
- Do not alter or modify equipment. Alterations or modifications may void agency approvals and create safety hazards.
- Make sure all equipment is rated and approved for the environment in which you are using it.
- Use equipment only for its intended purpose. Call your distributor for information.
- Route hoses and cables away from traffic areas, sharp edges, moving parts, and hot surfaces.
- Do not kink or over bend hoses or use hoses to pull equipment.
- Keep children and animals away from work area.
- Comply with all applicable safety regulations.

# **WARNING**



## **TOXIC FLUID OR FUMES HAZARD**

Toxic fluids or fumes can cause serious injury or death if splashed in the eyes or on skin, inhaled or swallowed.

- Read Safety Data Sheets (SDSs) for handling instructions and to know the specific hazards of the fluids you are using, including the effects of long-term exposure.
- When spraying, servicing equipment, or when in the work area, always keep work area well-ventilated and always wear appropriate personal protective equipment. See **Personal Protective Equipment** warnings in this manual.
- Store hazardous fluid in approved containers, and dispose of it according to applicable guidelines.



## **PERSONAL PROTECTIVE EQUIPMENT**

Always wear appropriate personal protective equipment and cover all skin when spraying, servicing equipment, or when in the work area. Protective equipment helps prevent serious injury, including long-term exposure; inhalation of toxic fumes, mists or vapors; allergic reaction; burns; eye injury and hearing loss. This protective equipment includes but is not limited to:

- A properly fitting respirator, which may include a supplied-air respirator, chemically impermeable gloves, protective clothing and foot coverings as recommended by the fluid manufacturer and local regulatory authority.
- Protective eyewear and hearing protection.

# Important Isocyanate (ISO) Information

Isocyanates (ISO) are catalysts used in two component materials.

## Isocyanate Conditions



Spraying or dispensing fluids that contain isocyanates creates potentially harmful mists, vapors, and atomized particulates.

- Read and understand the fluid manufacturer's warnings and Safety Data Sheets (SDSs) to know specific hazards and precautions related to isocyanates.
- Use of isocyanates involves potentially hazardous procedures. Do not spray with this equipment unless you are trained, qualified, and have read and understood the information in this manual and in the fluid manufacturer's application instructions and SDSs.
- Use of incorrectly maintained or mis-adjusted equipment may result in improperly cured material. Equipment must be carefully maintained and adjusted according to instructions in the manual.
- To prevent inhalation of isocyanate mists, vapors, and atomized particulates, everyone in the work area must wear appropriate respiratory protection. Always wear a properly fitting respirator, which may include a supplied-air respirator. Ventilate the work area according to instructions in the fluid manufacturer's SDSs.
- Avoid all skin contact with isocyanates. Everyone in the work area must wear chemically impermeable gloves, protective clothing and foot coverings as recommended by the fluid manufacturer and local regulatory authority. Follow all fluid manufacturer recommendations, including those regarding handling of contaminated clothing. After spraying, wash hands and face before eating or drinking.

## Moisture Sensitivity of Isocyanates

Exposure to moisture (such as humidity) will cause ISO to partially cure, forming small, hard, abrasive crystal that become suspended in the fluid. Eventually a film will form on the surface and the ISO will begin to gel, increasing in viscosity.

### NOTICE

Partially cured ISO will reduce performance and the life of all wetted parts.

- Always use a sealed container with a desiccant dryer in the vent, or a nitrogen atmosphere. **Never** store ISO in an open container.
- Keep the ISO pump wet cup or reservoir (if installed) filled with appropriate lubricant. The lubricant creates a barrier between the ISO and the atmosphere.
- Use only moisture-proof hoses compatible with ISO.
- Never use reclaimed solvents, which may contain moisture. Always keep solvent containers closed when not in use.
- Always lubricate threaded parts with an appropriate lubricant when reassembling.

**NOTE:** The amount of film formation and rate of crystallization varies depending on the blend of ISO, the humidity, and the temperature.

## Changing Materials

### NOTICE

Changing the material types used in your equipment requires special attention to avoid equipment damage and downtime.

- When changing materials, flush the equipment multiple times to ensure it is thoroughly clean.
- Always clean the fluid inlet strainers after flushing.
- Check with your material manufacturer for chemical compatibility.
- When changing between epoxies and urethanes or polyureas, disassemble and clean all fluid components and change hoses. Epoxies often have amines on the B (hardener) side. Polyureas often have amines on the B (resin) side.

# Component Identification

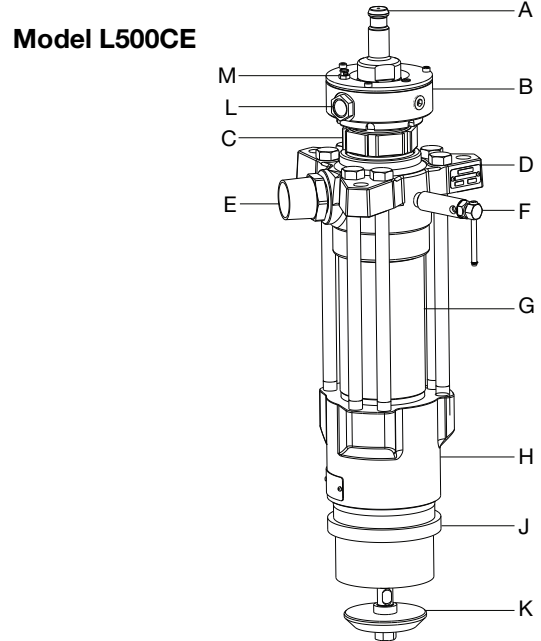
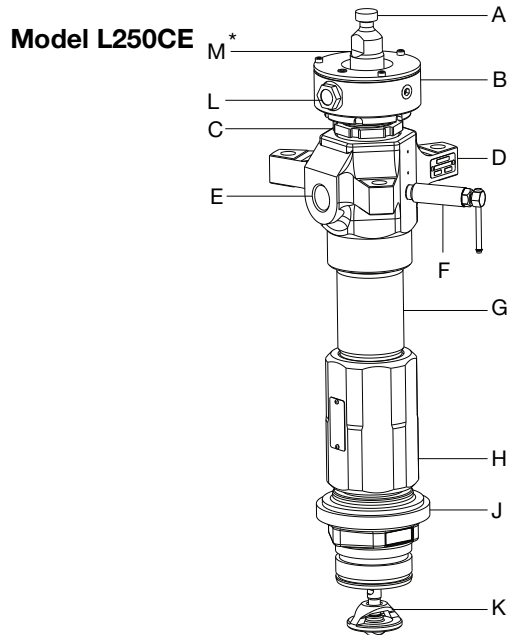
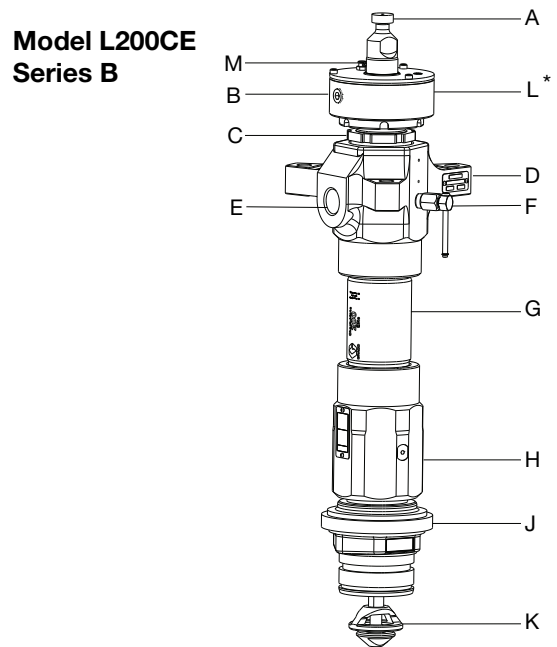
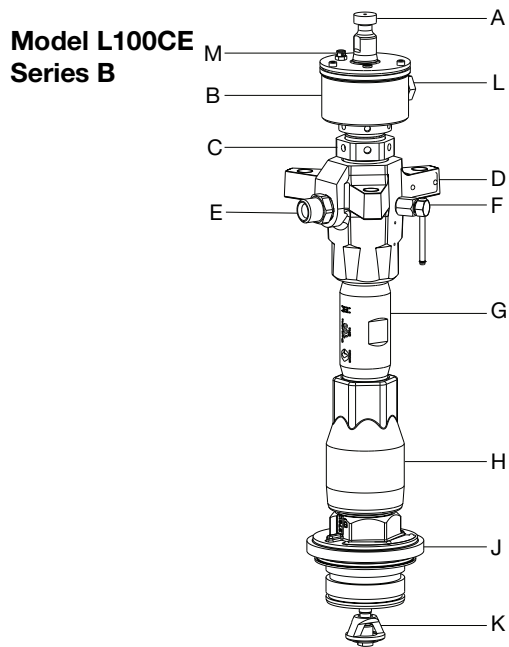

**FIG. 2:**

**Key:**

- A Displacement Rod
- B Wet Cup
- C Throat Packing Cartridge
- D Outlet Housing
- E Fluid Outlet
- F Pump Bleed Valve
- G Pump Cylinder

- H Intake Valve Housing
- J Intake Cylinder
- K Priming Piston Assembly
- L Wet Cup Sight Glass
- M Wet Cup Fill Cap
- \* Not shown in the drawing



# Operation

## Pressure Relief Procedure



Follow the Pressure Relief Procedure whenever you see this symbol.

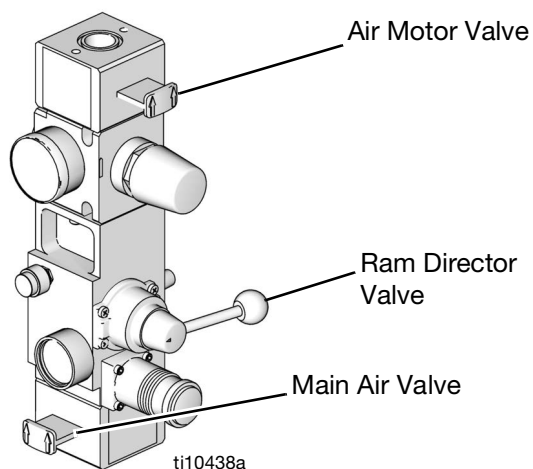

This equipment stays pressurized until pressure is manually relieved. To help prevent serious injury from pressurized fluid, such as skin injection, splashing fluid and moving parts, follow the Pressure Relief Procedure when you stop spraying and before cleaning, checking, or servicing the equipment.

1. Engage the gun/valve trigger.
2. **For D200s, D200, D60 and S20 Air Controls:** See FIG. 3.
  - a. Close the air motor slider valve and the main air slider valve.
  - b. Set the ram director valve to DOWN. The ram will slowly drop.
  - c. Jog the director valve up and down to bleed air from ram cylinders. See FIG. 3.

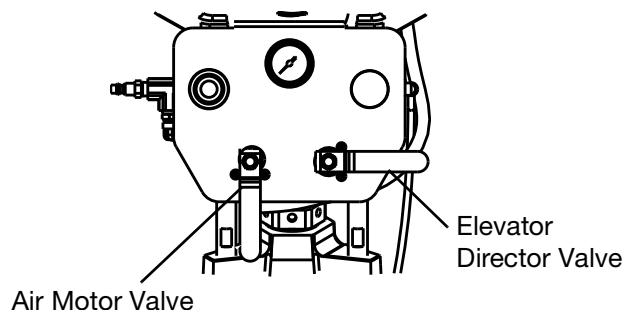

**FIG. 3**

3. **For L20c Air Controls:** See FIG. 4.
  - a. Close the bleed type air motor valve and the elevator director valve. The ram will slowly drop. See FIG. 4.



**FIG. 4**

4. Engage the gun/valve trigger lock.
5. Hold a metal part of the gun/valve firmly to the side of a grounded metal pail, and trigger the gun/valve to relieve pressure.
6. Engage the gun/valve trigger.
7. Open the fluid line drain valve and the pump bleed valve (P). Have a container ready to catch the drainage.
8. Leave the pump bleed valve open until ready to spray again. See FIG. 5.

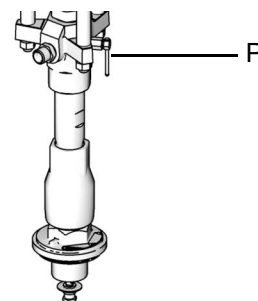

**FIG. 5**

If you suspect that the spray tip/nozzle or hose is completely clogged, or that pressure has not been fully relieved after following the steps above, very slowly loosen the tip guard retaining nut, nozzle, or hose end coupling and relieve pressure gradually, then loosen completely. Now clear the tip/nozzle or hose.

# Recycling and Disposal

## End of Product Life

At the end of the product's useful life, dismantle and recycle it in a responsible manner.

- Perform the **Pressure Relief Procedure** page 9.
- Drain and dispose of fluids according to applicable regulations. Refer to the material manufacturer's Safety Data Sheet.
- Deliver remaining product to a recycling facility.

# Troubleshooting



1. Follow **Pressure Relief Procedure**, page 9.
2. Check all possible problems and causes before disassembling pump.

Problem	Cause	Solution
Pump fails to operate.	Restricted line or inadequate air supply; closed or clogged valves.	Clear; increase air supply. Ensure that all valves are open.
	Obstructed fluid hose or gun/valve; fluid hose ID is too small.	Open, clear*; use a hose with a larger ID.
	Fluid dried on displacement rod.	Clean. Always stop pump at bottom of stroke. Keep enclosed grease cup filled with a compatible grease.
	Dirty, worn, or damaged motor parts.	Clean or repair; see separate motor manual.
	Runaway occurred.	See runaway section of Supply Units Operation manual 313526.
Pump operates but output is low on both strokes.	Restricted line or inadequate air supply; closed or clogged valves.	Clear; increase air supply. Ensure all valves are open.
		Increase air pressure to ram for better loading.
	Obstructed fluid hose or gun/valve; fluid hose ID is too small.	Open, clear*; use a hose with a larger ID.
	Bleed-type air valve is partially open.	Close bleed-type air valve.
	Air is leaking into supply container.	Check ram plate seal.
	Fluid is too heavy for pump priming.	Use drain/purge valve. Use a ram. See Supply Units Operation manual 313526.
	Held open or worn intake valve or seals.	Clear valve; replace seals.
	Worn packings in displacement pump.	Replace packings.
Pump operates, but output is low on downstroke.	Fluid is too heavy for pump priming.	Use drain/purge valve. Use a ram. See Supply Units Operation manual 313526.
	Held open or worn intake valve or seals.	Clear valve. Replace seals.
Pump operates, but output is low on upstroke.	Held open or worn intake valve or seals.	Clear valve. Replace seals.

Problem	Cause	Solution
Erratic or accelerated pump speed.	Exhausted fluid supply.	Refill and prime.
	Fluid is too heavy for pump priming.	Use drain/purge valve. Use a ram. See Supply Units Operation manual 313526.
		Increase ram air pressure.
	Held open or worn intake valve or seals.	Clear valve. Replace seals.
	Held open or worn priming piston.	Clear; service.
	Worn packings in displacement pump.	Replace packings.

\* To determine if fluid hose or gun is obstructed, follow **Pressure Relief Procedure**, page 9. Disconnect fluid hose and place a container at pump fluid outlet to catch any fluid. Turn on air just enough to start pump. If pump starts when air is turned on, the obstruction is in the fluid hose or gun.

# Repair

## Required Tools

- Torque wrench
- Bench vise, with soft jaws
- Rubber mallet
- Hammer
- 400 mm (15.8 in.) adjustable wrench
- O-ring pick
- Flat head screwdriver
- 13 mm (1/2 in.) dia. brass rod
- Set of socket wrenches
- Set of adjustable wrenches
- Packing nut wrench (supplied with pump package)
- 24 in. (610 mm) adjustable wrench
- M4 hex key wrench
- Thread lubricant
- Thread sealant
- Loctite® 2760™ or equivalent

## Disassembly and Reassembly of Throat Packings and Cartridge

All new Check-Mate displacement pumps are equipped with a throat seal cartridge (143) that enables easy removal and replacement of throat seal without the complete disassembly of the displacement pump.

1. Run air motor and displacement pump to bottom of stroke.
2. Relieve pressure see **Pressure Relief Procedure**, page 9.
3. Remove air motor coupling assembly from displacement rod. See Check-Mate Pump Packages manual 312376 for instructions.
4. Push air motor piston rod up to top of stroke.
5. Remove wet cup cover (present on enclosed wet cups only).
6. Place an absorbent cloth in wet cup (144) to absorb Throat Seal Liquid (TSL).

7. Use packing nut wrench (supplied) to loosen and remove packing nut/enclosed wet cup (144).

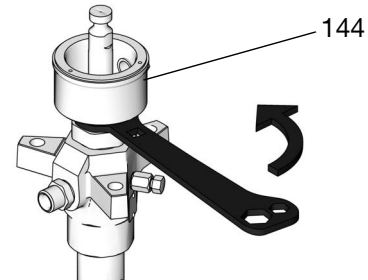

**FIG. 6**

8. Use an adjustable wrench to loosen cartridge (143); slide it and throat seal (145) up and off displacement rod (118).

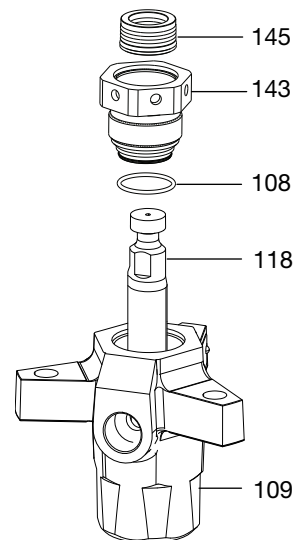

**FIG. 7**

9. Replace throat seal (145) into cartridge (143).
10. Remove and replace o-ring (108).
11. Slide cartridge (143) and throat seal (145) back on to displacement rod (118). Be careful to not damage throat seal.

- Torque cartridge (143) to specified torque listed in the following table.

Displacement Pump	Torque
100cc	90-130 ft-lbs (122-173 N•m)
200cc and 250cc	130-190 ft-lbs (176-258 N•m)
500cc	149-261 ft-lbs (203-355 N•m)

- Slide packing nut/wet cup (144) over displacement rod (118) and torque to specified torque listed in the following table.

Displacement Pump	Torque
100cc	28-44 ft-lbs (38-59 N•m)
200cc and 250cc	95-115 ft-lbs (128-155 N•m)
500cc	95-115 ft-lbs (128-155 N•m)

- Fill wet cup (144) 1/3 full of TSL or compatible solvent.

## Disassembly

When disassembling displacement pump, lay out all removed parts in sequence to ease reassembly. Clean all parts with a compatible solvent and inspect them for wear or damage.



- Relieve pressure see **Pressure Relief Procedure**, page 9.
- Disconnect displacement pump from air motor as illustrated in your Check-Mate Pump Packages manual 312376.
- Place displacement pump in a vise, with jaws on outlet housing (109).

- Use packing nut wrench (supplied) to loosen and remove packing nut/enclosed wet cup (144).

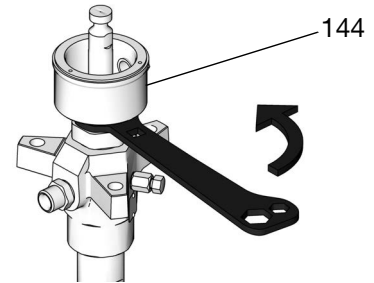

**FIG. 8**

- On displacement pumps with enclosed wet cups (144), use an M4 hex wrench to remove the three screws (152) from wet cup cover (153) and remove cover. Drain and clean out the wet cup (144). See FIG. 9.
- On displacement pumps with enclosed wet cups (144), use o-ring pick to remove o-ring (149), and a flat head screwdriver to remove snap ring (146), wiper (148), and seal (147).

**NOTE:** The snap ring (146) is applicable only to 100cc displacement pumps.

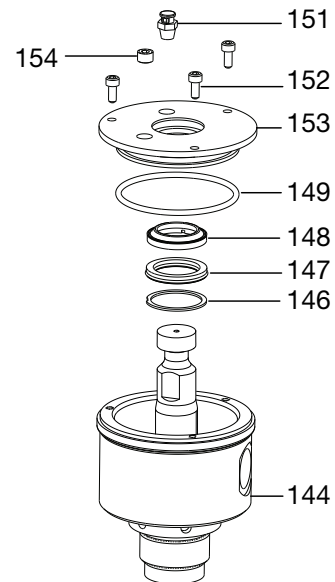

**FIG. 9**

**NOTE:** Steps 7-13 apply to 100cc, 200cc, and 250cc displacement pumps only.

7. Push on the upper displacement rod (118) to expose flats of the lower shaft assembly (125). Hold flats of the lower shaft assembly (125) with an adjustable wrench, and use a second wrench to unscrew shovel nut (133) from lower shaft assembly. Slide shovel piston (132) off rod. Inspect surfaces of shovel nut and lower shaft assembly for scoring, wear, or other damage. See FIG. 10.

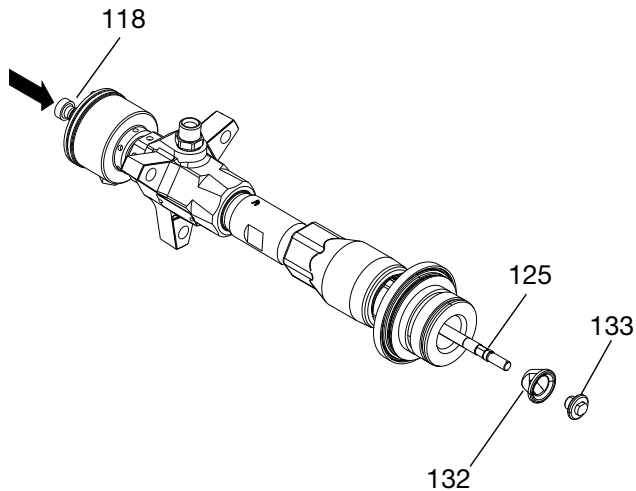

**FIG. 10**

8. Use an adjustable wrench on hex of intake cylinder (131) to unscrew it from intake valve housing (117).

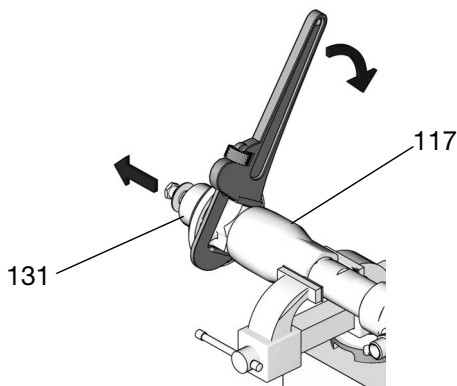

**FIG. 11**

9. Use an adjustable wrench to unscrew intake valve housing (117) from cylinder (116) and outlet housing (109). Pull intake valve housing off cylinder. Intake check valve assembly (126/127/128) should slide down priming piston rod (125) as you remove housing; if it does not slide easily, firmly tap on top of housing (117) with a rubber mallet to loosen.

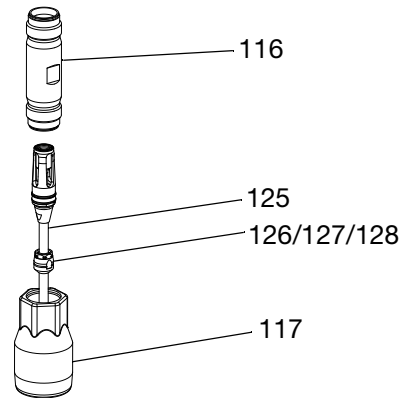

**FIG. 12**

10. Use a 400 mm adjustable wrench on flats of displacement pump cylinder (116) and unscrew cylinder from outlet housing (109). Remove o-rings (105). Inspect inside surface of cylinder for wear, scoring or other damage by holding it up to light at an angle or running a finger over the surface.

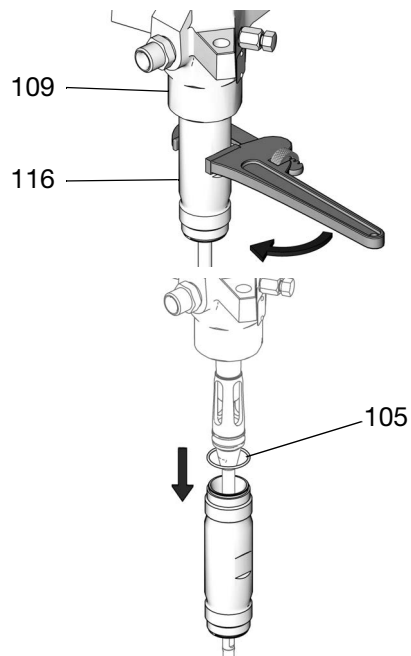

**FIG. 13**

11. Use an o-ring pick to remove seal (130) from intake valve housing (117). Discard seal; use a new one for reassembly. See FIG. 14.
12. Pull intake seat (129) out bottom of intake valve housing (117). Take care not to drop intake valve assembly (126/127/128) as it comes free, and set it aside for later.

**NOTE:** If seat (129) is difficult to remove, insert a hammer and brass rod through the top of housing (117) and drive seat out.

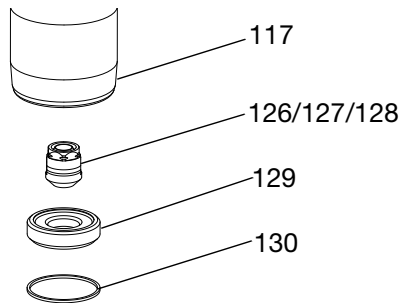

**FIG. 14**

13. Use a rubber mallet to drive displacement rod (118) and priming piston rod (125) out of outlet housing (109). Inspect outer surfaces of rods for damage by running a finger over the surface.

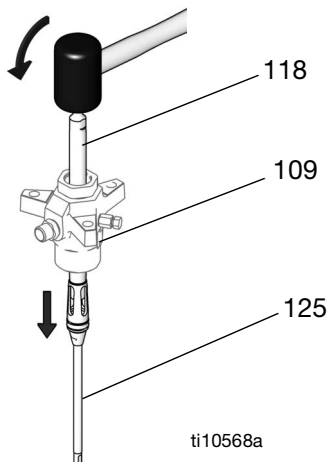

**FIG. 15**

**NOTE:** Steps 14-20 apply to 500cc displacement pumps only.

14. Hold flats of the priming piston rod (420) with an adjustable wrench, and use a second wrench to unscrew priming piston seat (423) from rod. Slide priming piston (422) off rod. Inspect surfaces of guide (421) and piston (422) for scoring, wear, or other damage.

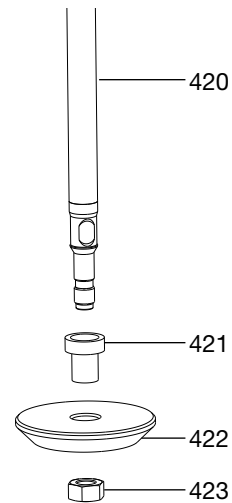

**FIG. 16**

15. Use a socket wrench to remove six capscrews (438).

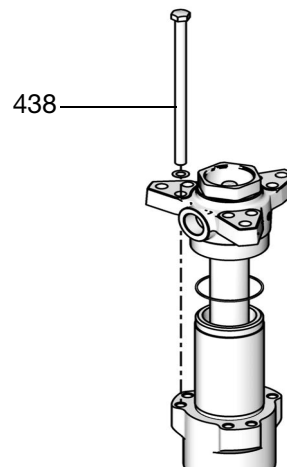

**FIG. 17**



- 16. Tap underside of outlet housing (402) with a rubber mallet to loosen housing from cylinder (414). Lift outlet housing off displacement pump and set it aside. Be careful not to scratch displacement rod (401) while removing housing. Remove o-ring (415) from top of cylinder.
- 17. Lift cylinder (414) up off intake housing (418). Displacement rod (401), piston assembly, intake valve assembly, and priming piston rod (420) will come with cylinder.
- 18. Place cylinder (414) sideways in a vise with soft jaws. Using a rubber mallet on end of priming piston rod (420), drive displacement rod (401) and piston assembly out of the top of the cylinder. Continue to pull rod out of cylinder until priming piston rod (420) comes free.
- 19. Remove o-ring (415) from bottom of cylinder (414). Hold cylinder up to light at an angle to examine inside surface for scoring and damage.
- 20. Pull o-ring (415) and seat (417) out the top of the intake housing (418). If seat is difficult to remove, turn housing upside down and drive seat out using a hammer and brass rod.

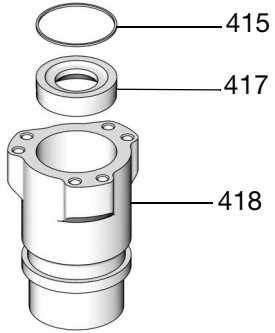

FIG. 18

- 21. Examine mating surfaces of seat (129) and intake valve body (128) for damage.
- 22. To access throat packings and glands, use an adjustable wrench to remove the throat cartridge (143).
- 23. Remove cartridge o-ring (108). Then remove throat seal (145) from throat cartridge (143). Some models include a fluid outlet nipple (111) and o-ring (110). Do not remove these parts from housing unless they need replacement.

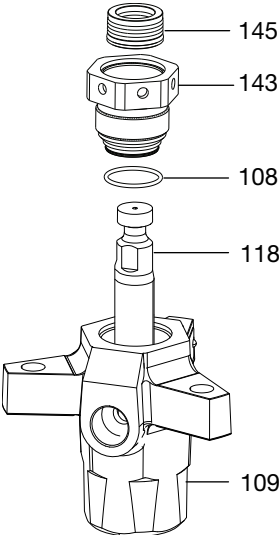
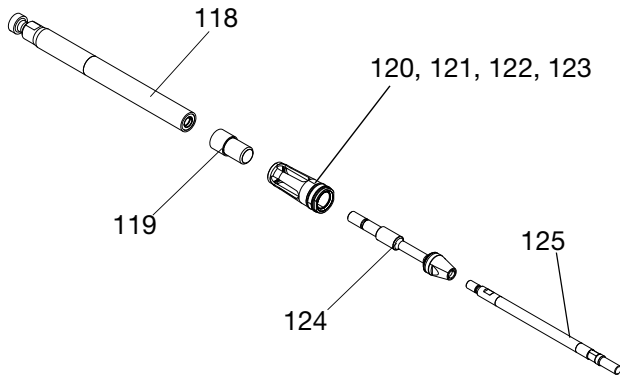

FIG. 19

**NOTE:** Steps 24-25 apply to 100cc and 200cc displacement pumps only.

24. Place flats of the upper displacement rod (118) in a bench vise. Unscrew the lower shaft assembly (125) from the outlet check valve seat (124). Unscrew the outlet check valve seat from the upper displacement rod. Remove the piston guide and seal assembly (121, 122, 123, and 124) and the pump rod spacer (119).
25. Inspect the outer surfaces of the upper displacement rod (118) and the lower shaft assembly (125) for wear, scoring or any other damage by holding them up to the light at an angle or running a finger across the surface.



**FIG. 20**

**NOTE:** Steps 26-27 apply to 250cc and 500cc displacement pumps only.

26. Place flats of displacement rod (401) in a vise. Unscrew piston (419) from displacement rod; priming piston rod (420) will come with it. Slide piston guide (424) and seat (426) off piston (419).
27. Inspect outer surfaces of displacement rod (401) and priming piston rod (420) for wear, scoring or other damage by holding them up to light at an angle or running a finger over the surface.

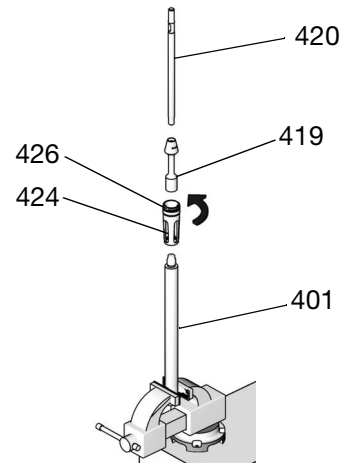
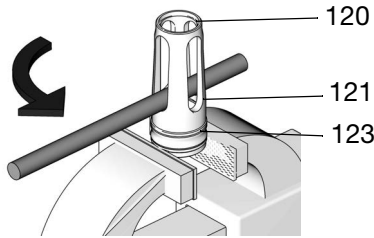

**FIG. 21**

**NOTE:** It is not necessary to remove priming piston rod (125) from piston (124) unless your inspection reveals scoring, wear, or other damage to either part. To disassemble, place piston flats in a vise and unscrew the rod.

28. Place piston seat (123) and guide (121) in vise. Slide a brass rod through openings in piston guide and unscrew it from seat. Remove piston seal (122) and guide bearing (120).

**NOTE:** Guide bearing (120) is press-fit into the piston guide (121), and may require cutting to ease removal.



**FIG. 22**

29. To disassemble the intake check valve assembly, remove the internal retaining ring (126) from the poppet inlet check valve (128). Using a small screwdriver or O-ring pick remove the lower shaft seals (127). Inspect the poppet inlet check valve for wear or damage.

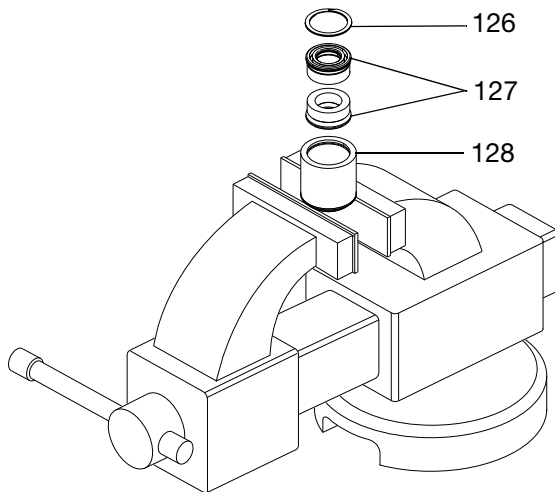

**FIG. 23**

30. Unscrew bleeder valve plug (113) completely from valve body (112). Clean valve threads and bleed hole. It is not necessary to remove valve body from displacement pump outlet housing (109).

31. Inspect all parts for damage. Clean all parts and threads with a compatible solvent. Reassemble as explained in the **NOTE: Steps 11-13 apply to 250cc and 500cc displacement pumps only.** section.

## Reassembly

**NOTE:** All individual parts being reused from any disassembly must be thoroughly cleaned in a compatible solvent and inspected for damage.

**NOTE:** Steps 1-6 apply to 100cc displacement pumps only.

1. Lubricate the inside diameter of the poppet inlet check valve (128) body, the seal guide tool (135) and if used the seal insertion tool (134). Also lubricate the outside diameter of the lower shaft seals (127).
2. Place the seal guide tool (135) on top of the poppet inlet check valve (128). Place the first lower shaft seal (127) with the seal face (spring side), face down into the seal guide tool.

**NOTICE**

Failure to use the seal guide tool (135) on the L100CE pump will result in damage to the seal.

3. Using the smaller heel side of the seal insertion tool (134), or a suitable size socket or dowel, press the seal to the bottom of the poppet inlet check valve (128).

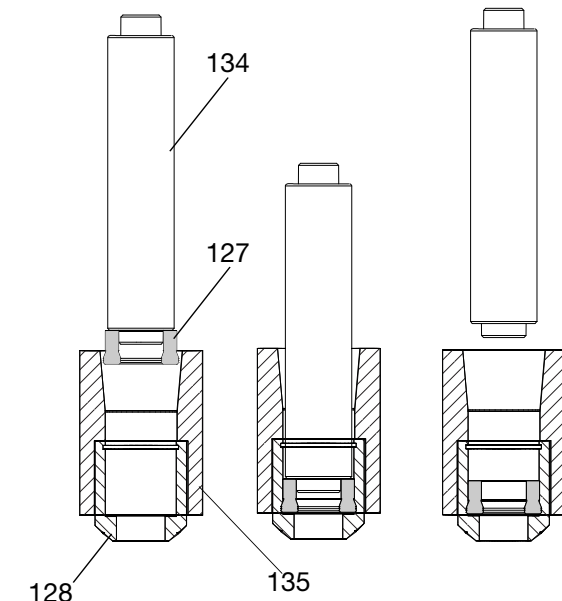

**FIG. 24**

4. Place the second lower shaft seal (127) face up into the seal guide tool (135). Insert the lower shaft seal using the larger face side of the seal insertion tool (134), or a suitable size socket or dowel.
5. Press the seal into the poppet inlet check valve (128) against the first lower shaft seal (127).

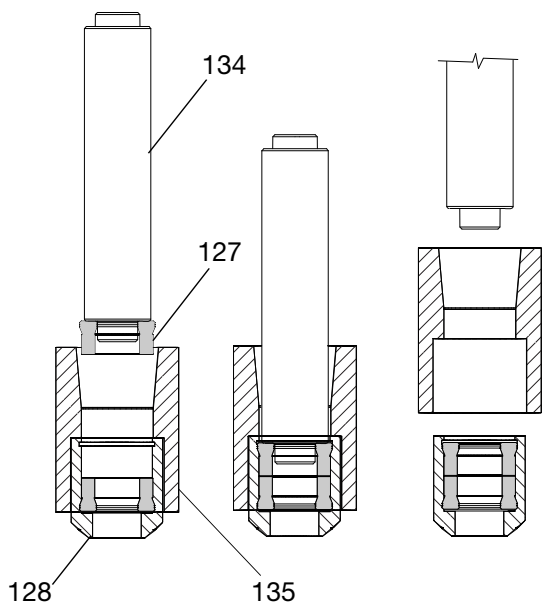

FIG. 25

6. Place the internal retaining ring (126) into the groove at the top of the poppet inlet check valve (128).

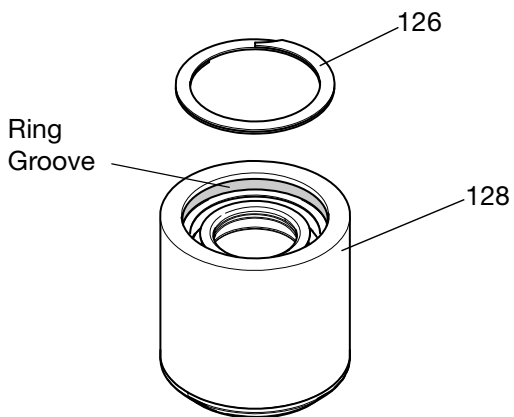

FIG. 26

**NOTE:** Steps 7-10 apply to 200cc displacement pumps only.

7. Lubricate the inside diameter of the poppet inlet check valve (221) body and the outside diameter of the lower shaft seals (220). Also lubricate a suitable size socket or dowel that will be used to insert the seals.
8. Using a suitable size socket or dowel, insert the lower shaft seals (220) with the seal face (spring side) facing down press the seal to the bottom of the poppet inlet check valve (221).
9. Place the second lower shaft seal (220) face up into the poppet inlet check valve (221). Insert using a suitable size socket or dowel.

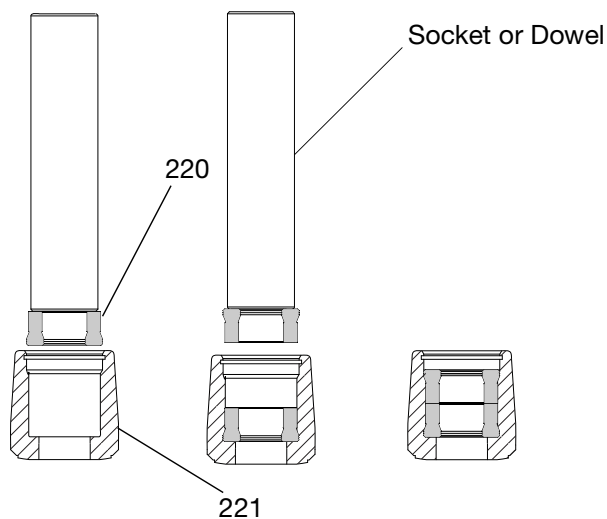

FIG. 27

10. Place the lower steel spacer (219) on top of the second lower shaft seal (220). Next snap the internal retaining ring (218) into the groove at the top of the poppet inlet check valve (221).

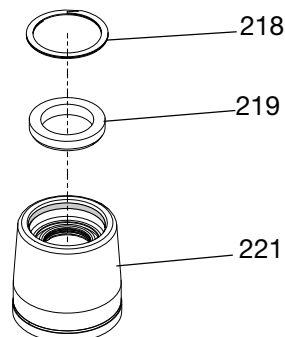
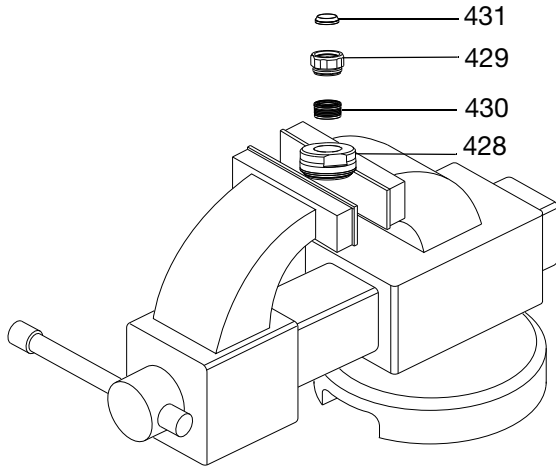

FIG. 28

**NOTE:** Steps 11-13 apply to 250cc and 500cc displacement pumps only.

11. Lubricate the intake valve (430) and install them in valve (428). See FIG. 29.
12. With beveled side facing up, press intake valve seal (431) in to recess of intake valve packing nut (429) until it snaps into place. The nose of the seal should be flush with or slightly recessed into the face of the packing nut. See FIG. 29.
13. Place flats of valve body (428) in a vise. Screw packing nut (429) into valve body handtight. Set intake housing assembly aside.



**FIG. 29**

14. Lubricate piston seal (122) and install it on piston seat (123). Screw piston guide (121) onto seat (123). Place piston seat in a vise and use a brass rod to torque guide; see the following table for correct torque. Snap guide bearing (120) into piston guide (121).

Displacement Pump	Torque
100cc	26-30 ft-lbs (35-41 N•m)
200cc and 250cc	57-63 ft-lbs (77-85 N•m)
500cc	90-100 ft-lbs (122-135 N•m)

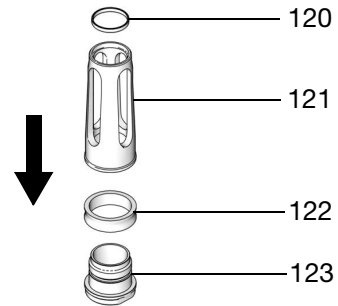

**FIG. 30**

15. If it was necessary to remove the priming piston rod (125) from the piston (124), apply thread sealant to threads of the rod. Place flats of piston in a vise. Hold flats of rod with an adjustable wrench, and screw rod into piston; see the following table for correct torque. Be careful not to create burrs on flats of rod.

Displacement Pump	Torque
100cc	34-38 ft-lbs (46-51 N•m)
200cc and 250cc	92-102 ft-lbs (124-138 N•m)
500cc	90-100 ft-lbs (122-135 N•m)

**NOTE:** Step 16 apply to 100cc and 200cc displacement pumps only.

16. Place the flats of the upper displacement rod (118) into a bench vise. Clean any residual thread locker from the threads of the outlet check valve seat (124) and reapply a bead of thread locker to the threads. Place the pump rod spacer (119) into the outlet check assembly (120,121,122, and 123). Insert the upper check valve seat through the outlet check assembly and thread into the upper displacement rod (118).

Displacement Pump	Torque
100cc and 200cc	50 Ft-lb (67.79 N•m)

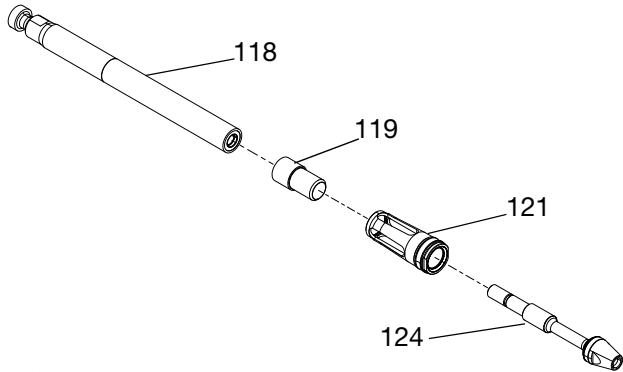
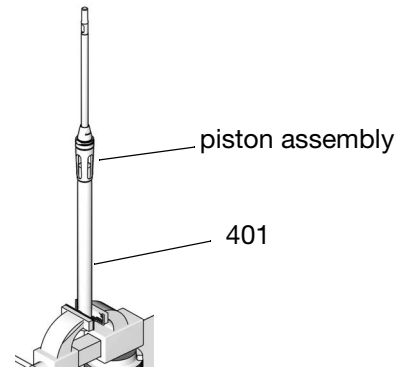

**FIG. 31**

**NOTE:** Step 17 apply to 250cc and 500cc displacement pumps only.

17. Place flats of displacement rod (401) in a vise. Install piston seat/guide assembly onto the piston (419). Apply thread sealant to threads of rod and screw piston assembly onto rod; see the following table for correct torque.

Displacement Pump	Torque
250cc	239-271 ft-lbs (323-366 N•m)
500cc	327-363 ft-lbs (441-490 N•m)



**FIG. 32**

**NOTE:** Steps 18- 23 apply to 100cc, 200cc, and 250cc displacement pumps only.

- Lubricate o-ring (105) and place it on top of the cylinder (116). Screw cylinder handtight into outlet housing (109). The cylinder is symmetrical so either end can be the top.

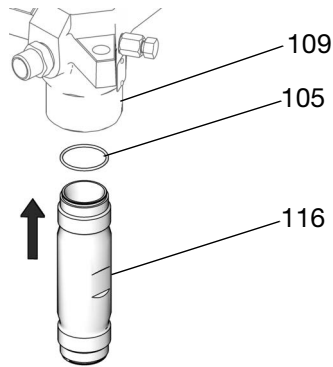

**FIG. 33**

- Carefully insert displacement rod (118) into bottom of cylinder (116). Push rod up into cylinder and through outlet housing (109). Be careful not to damage piston seal (122) while performing this step.

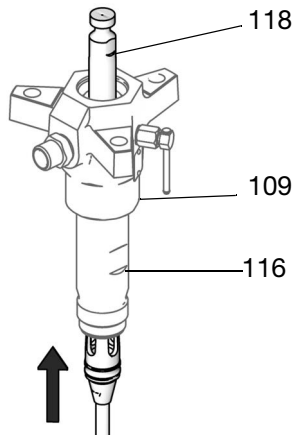

**FIG. 34**

- Lubricate o-ring (105) and install it on the bottom of cylinder (116). Slide intake valve housing (117) onto priming piston rod (125). Ensure smooth surface of valve stop faces displacement pump intake. Screw housing onto cylinder.

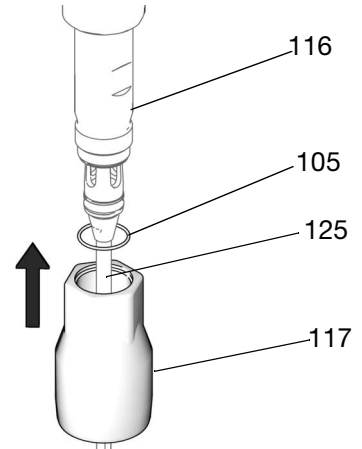

**FIG. 35**

- Lubricate priming piston rod (125), then slide assembled intake valve onto rod (126/127/128).

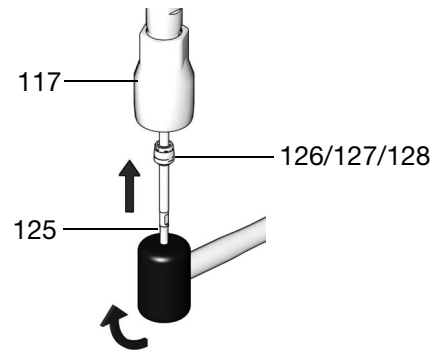

**FIG. 36**

- The intake seat (129) is reversible on the 200cc and 250cc displacement pumps. Inspect both sides of seat and install it with the best side facing into housing (117). Push it into housing until it seats securely. Lubricate seal (130) and install in the bevel around the bottom of the seat.

**NOTE:** For 100cc displacement pumps, install intake seat (129) so large beveled side faces down toward pump intake.

23. Lubricate threads of intake cylinder (131). Use an adjustable wrench to screw intake cylinder into intake valve housing (117). Torque intake cylinder; see the following table for correct torque. This will also torque intake valve housing (117) and displacement pump cylinder (116) into outlet housing (109).

Displacement Pump	Torque
100cc	213-287 ft-lbs (288-387 N•m)
200cc and 250cc	345-435 ft-lbs (466-587 N•m)

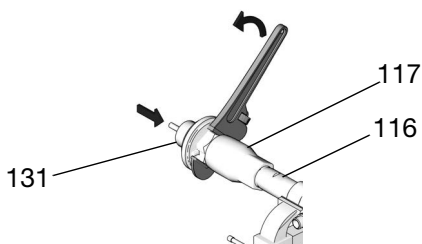

FIG. 37

**NOTE:** Steps 24-31 apply to 500cc displacement pumps only.

24. Slide rod guide (416) onto priming piston rod (420) ensuring the end nearest valve stop goes on rod first.
25. Slide assembled intake valve onto priming piston rod (420) ensuring packing nut (429) goes on rod first. Push valve assembly up rod, stopping before it reaches rod guide (416).
26. Hold valve body (428) steady with a wrench while using an adjustable wrench to tighten packing nut (429). Torque to 71-78 ft-lbs (97-106 N•m). Use a hammer and a brass rod to carefully drive valve assembly further up rod until it reaches the stop.
27. Place cylinder (414) sideways in a vise with soft jaws.
28. Lubricate o-ring (415) and place it on bottom of cylinder (414). (Cylinder is symmetrical so either end can be the bottom.)
29. Slide displacement rod (401), piston assembly (419/426/427), intake valve assembly (428/429/430/431), and priming piston rod (420) into cylinder (414) from bottom until mating surfaces of rod guide (416) and cylinder (414) meet.

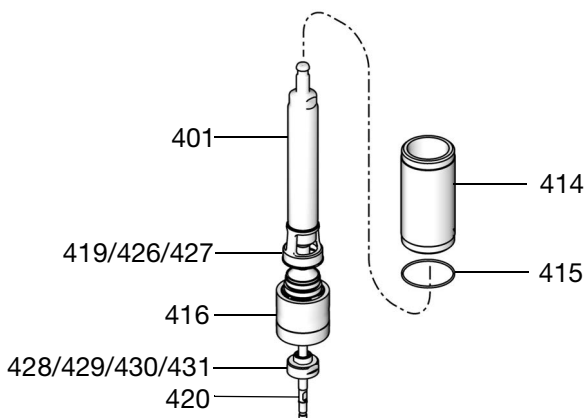

FIG. 38



30. Put intake housing (418) upright in a vise, making sure it is off-center so there is a sufficient clearance for priming piston rod (420) to be lowered through housing. Insert intake seat (417) into intake housing (418) so the flat seat is facing up. Lubricate o-ring (415) and place it on top of intake seat (417). Lower rod and cylinder assembly into intake housing until rod guide (416) bottoms on intake seat (417) and priming piston rod (420) protrudes from bottom of intake housing (418).

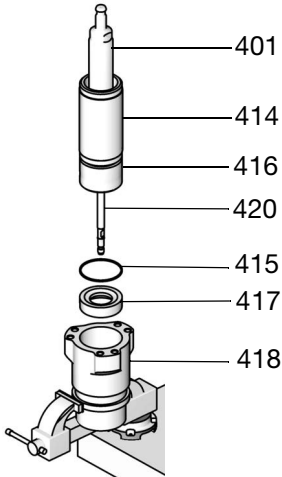

FIG. 39

31. Lubricate o-ring (415) and place it on top of cylinder (414). Insert outlet housing (402) on to cylinder. Install six long capscrews (438) through outlet housing (402) and into intake housing (418). Using a socket wrench, torque screws oppositely and evenly to 180-195 ft-lbs (244-264 N•m).

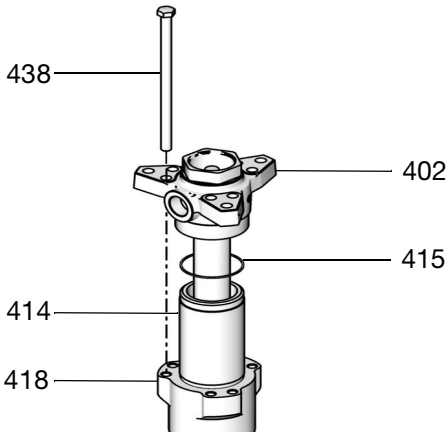

FIG. 40

32. Lubricate throat seal (145), and install it in throat cartridge (143).  
 33. Partially thread wet cup (144) into cartridge (143) to hold packings in place during installation. Install new cartridge o-ring (108) on cartridge (143). Apply thread lubricant to cartridge (143) and carefully slide down over displacement rod and into outlet housing (109). Torque cartridge to the following torque. Be careful not to damage throat packings on leading edge of rod.

Displacement Pump	Torque
100cc	90-130 ft-lbs (122-176 N•m)
200cc and 250cc	130-190 ft-lbs (176-257 N•m)
500cc	150-261 ft-lbs (203-355 N•m)

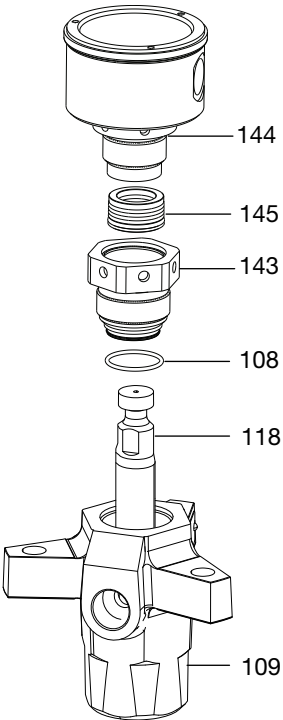

FIG. 41

34. Use packing nut wrench (supplied) to tighten wet cup (144) to specified torque; refer to the following table.

Displacement Pump	Torque
100cc	28-44 ft-lbs (38-59 N•m)
200cc and 250cc	95-115 ft-lbs (128-155 N•m)
500cc	95-115 ft-lbs (128-155 N•m)

35. Lubricate the threads of the bleeder valve plug (113). The plug has two sets of threads. Be sure to screw the plug completely into the valve body (112). Torque the plug to 9-11 ft-lbs (12-15 N•m)

**NOTE:** Some models include an outlet nipple (111) and o-ring (110). It is not ordinarily necessary to remove these parts. However, if they were replaced because of damage, lubricate o-ring and place it on nipple. Screw nipple into outlet housing (109). Torque to 44-62 ft-lbs (60-84 N•m).

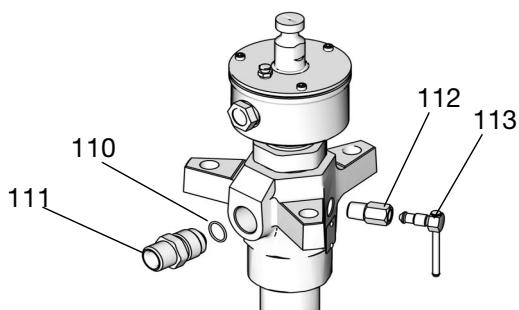

FIG. 42

36. Install new o-ring (149), wet cup wiper (148), seal (147), and snap ring (146) into wet cup cover (153). See FIG. 43.

**NOTE:** The snap ring (146) is applicable only to 100cc displacement pumps.

37. Carefully slide wet cup cover (153) over displacement rod (118). Line up holes in cover and wet cup. Insert screws (152). Use a hex head screwdriver to tighten screws. See FIG. 43.

**NOTE:** Use caution when sliding wet cup cover (153) over displacement rod (118) to avoid damaging seals (147/148).

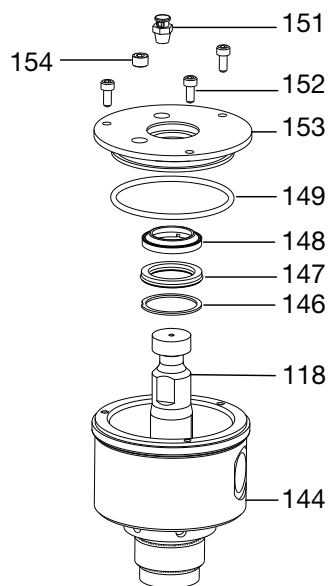

FIG. 43

38. Check that flats of priming piston rod (125) are accessible below intake cylinder (131). If not, tap on top of displacement rod (118) with a rubber mallet until flats are exposed.

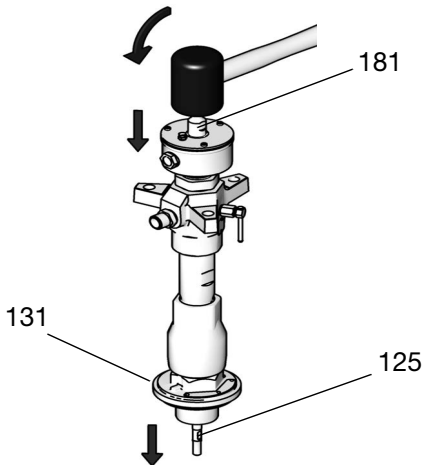

FIG. 44

**NOTE:** Step 39 apply to 100cc, 200cc and 250cc displacement pumps only.

39. Slide the shovel piston (132) onto the lower shaft assembly (125). Apply thread sealant to the threads on the lower shaft assembly and screw on the shovel nut (133). See Fig. 45. Torque to the following specifications:

Displacement Pump	Torque
100 cc	53 Ft-lbs (72 N•m)
200 cc	75 Ft-lbs (102 N•m)

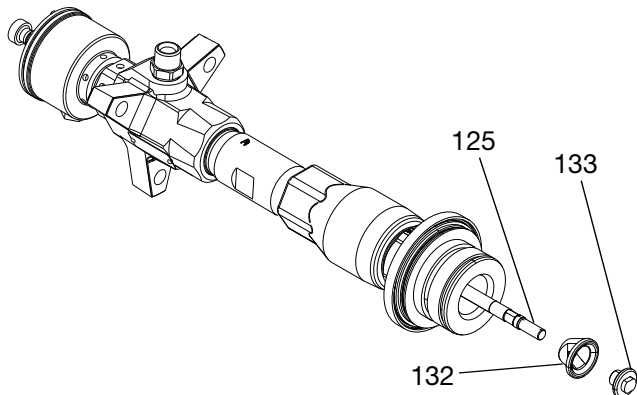

FIG. 45

**NOTE:** Step 40 apply to 500cc displacement pumps only.

40. Slide priming piston (422) and priming piston guide (421) onto rod (420) until it stops. Hold rod (420) steady with an adjustable wrench on flats, and screw seat (423) onto rod with another wrench. Torque to specified torque; refer to the following table.

Displacement Pump	Torque
500cc	71-79 ft-lbs (96-107 N•m)

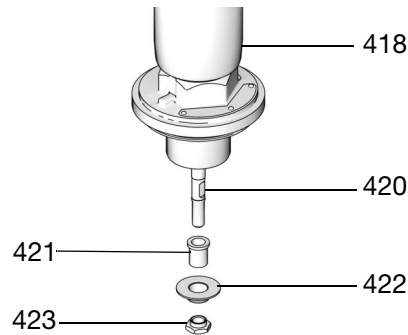

FIG. 46

41. Reconnect displacement pump to the air motor as explained in Check-Mate Pump Packages manual 312376.

42. Allow 2 hours for thread sealant to cure before returning pump to service.

# Parts

## 100 cc Displacement Pump L100CE

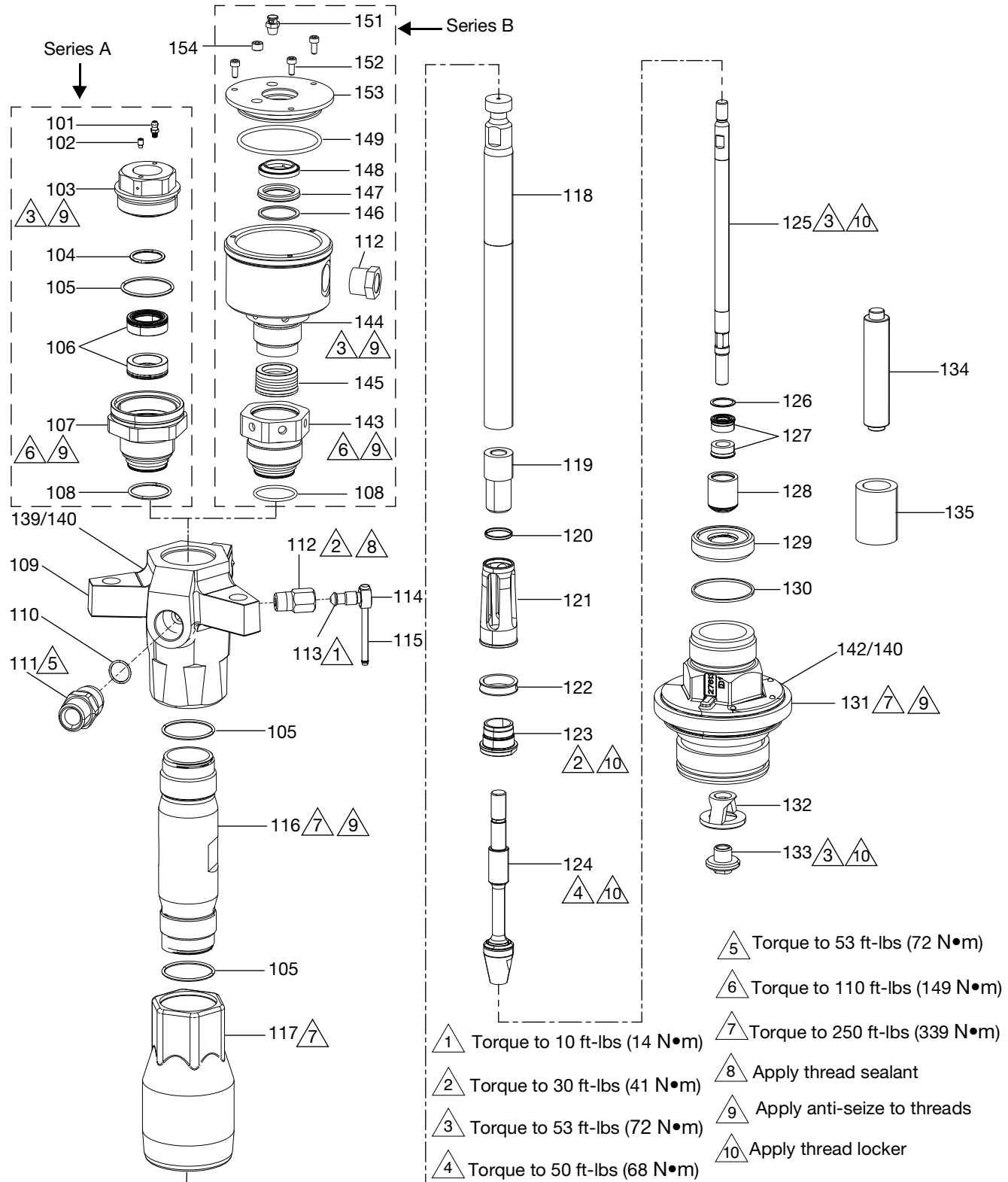

## 100 cc Displacement Pump L100CE Assembly Parts List

Ref.	Kit No. and Part No.	Description	Qty	Kit Number														
				Series A Kit	Series A and B Shared Kits									Series B Kits	Series A to Series B Upgrade Kit			
				Kit #1 26B924 <sup>(1)</sup>	Kit #2 2005346 <sup>(2)</sup>	Kit #3 26S927 <sup>(3)</sup>	Kit #4 26B928 <sup>(4)</sup>	Kit #5 26B929 <sup>(5)</sup>	Kit #6 26B930 <sup>(6)</sup>	Kit #7 26B938 <sup>(7)</sup>	Kit #8 26D212 <sup>(8)</sup>	Kit #9 26D213 <sup>(9)</sup>	Kit #10 26D214 <sup>(10)</sup>	Kit #11 2005347 <sup>(11)</sup>	Kit #12 255618 <sup>(12)</sup>	Kit #13 2006252 <sup>(13)</sup>	Kit #14 2005350 <sup>(14)</sup>	
101	-----	FITTING, grease, M5	1															
102	-----	SCREW, SHS, EXT tip, M5x8	1															
103	-----	RETAINER, shaft seals, C100, ES1	1															
104	Kit #1/ 15K234	PACKING, O-ring	1	1														
105	Kit #1/#10 166623	PACKING, O-ring	1	3														
106*	-----	SEAL, shaft, upper, C100, ES1	2															
107	-----	CARTRIDGE, seal, C100, ES1	1															
108	Kit #1/#11/#14 104361	PACKING, O-ring	1	1													1	
109	Kit #9	HOUSING, outlet,C100CE	1															
110	Kit #1/#11 110135	PACKING, O-ring PTFE	1	1														
111	184037	FITTING, outlet (6 cm)	1															
112	165702	HOUSING, valve	1															
113	190128	PLUG	1															
114	121133	HANDLE, outlet, bleed	1															
115	121134	CLIP, outlet, bleed	1															
116	Kit #10	CYLINDER, C100, ES1	1															
117	Kit #8	HOUSING, valve, C100CE	1															
118	Kit #5	ROD, displacement, upper, CM100	1															
119	-----	SPACER, pump, rod, C100, ES1	1															
120	Kit #2	BEARING, piston, guide, CM100	1															
121	-----	GUIDE, piston, 100 SST	1															
122	Kit #2	SEAL, piston, C100, ES1	1															
123	Kit #4	VALVE, check, out, poppet, C100, ES1	1															
124	Kit #4	VALVE, check, out, seat, C100, ES1	1															
125	Kit #6	SHAFT, assy, lower, C100, ES1	1															

Ref.	Kit No. and Part No.	Description	Qty	Kit Number													
				Series A Kit	Series A and B Shared Kits										Series B Kits	Series A to Series B Upgrade Kit	
				Kit #1 26B924 <sup>(1)</sup>	Kit #2 2005346 <sup>(2)</sup>	Kit #3 26S927 <sup>(3)</sup>	Kit #4 26B928 <sup>(4)</sup>	Kit #5 26B929 <sup>(5)</sup>	Kit #6 26B930 <sup>(6)</sup>	Kit #7 26B938 <sup>(7)</sup>	Kit #8 26D212 <sup>(8)</sup>	Kit #9 26D213 <sup>(9)</sup>	Kit #10 26D214 <sup>(10)</sup>	Kit #11 2005347 <sup>(11)</sup>	Kit #12 255618 <sup>(12)</sup>	Kit #13 2006252 <sup>(13)</sup>	Kit #14 2005350 <sup>(14)</sup>
126	Kit #2/#3	RING, retaining, int, 0.875 in. OD	1		1	1											
127	Kit #2	SEAL, shaft, lower, CM100 XL	2		2												
128	Kit #3	VALVE, check, in, poppet, C100, ES1	1			1											
129	Kit #3	VALVE, check in, seat, C100, ES1	1			1											
130	Kit #1/#11 187860	SEAL		1								1					
131	15U935	CYLINDER, intake (4.5)	1														
132	Kit #7	PISTON, shovel, C100, ES1	1						1								
133	Kit #7	NUT, shovel, C100, ES1	1						1								
134	15N358	TOOL insert, L100 elite	1														
135	Kit #2	TOOL, seal, guide, L100 ELITE	1		1												
136	All kits 113500	SEALANT, anaerobic, 5 cc pack	1	1	1	1	1	1	1	1	1	1	1	1	1	1	1
137	All Kits	LUBRICANT, anti-seize, 7g pack	1	1	1	1	1	1	1	1	1	1	1	1	1	1	1
138	0553-6	LUBRICANT, synthetic, hi-temp, grease	1														
139	184090 ▲	LABEL, warning	1														
140	100508	SCREW, drive	5														
141	172479 ▲✓	TAG, warning	1														
142	184151 ▲	LABEL, warning	1														
143	Kit #14 15K751	CARTRIDGE, cm450	1														1
144	Kit #13/#14	CUP, WET, cm100	1												1		1
145	Kit #2/#11/#14 2004841	THROAT SEAL, vee and u-cup, L100ce	1		1							1					1
146	Kit #12/#13/#14	RING, retaining	1											1	1		1
147	Kit #12/#13/#14	SEAL, cm100 wet cup cover	1											1	1		1
148	Kit #12/#13/#14	WIPER, cm100 wet cup cover	1											1	1		1
149	Kit #12/#13/#14	PACKING, O-ring, #233	1											1	1		1

Ref.	Kit No. and Part No.	Description	Qty	Kit Number														
				Series A Kit	Series A and B Shared Kits									Series B Kits	Series A to Series B Upgrade Kit			
				Kit #1 26B924 <sup>(1)</sup>	Kit #2 2005346 <sup>(2)</sup>	Kit #3 26S927 <sup>(3)</sup>	Kit #4 26B928 <sup>(4)</sup>	Kit #5 26B929 <sup>(5)</sup>	Kit #6 26B930 <sup>(6)</sup>	Kit #7 26B938 <sup>(7)</sup>	Kit #8 26D212 <sup>(8)</sup>	Kit #9 26D213 <sup>(9)</sup>	Kit #10 26D214 <sup>(10)</sup>	Kit #11 2005347 <sup>(11)</sup>	Kit #12 255618 <sup>(12)</sup>	Kit #13 2006252 <sup>(13)</sup>	Kit #14 2005350 <sup>(14)</sup>	
150	Kit #13/#14	SIGHTGLASS	1														1	1
151	Kit #13/#14	COVER, oil hole	1														1	1
152	Kit #13/#14	SCREW, shcs M5 X 12	3														3	3
153	Kit #13/#14	COVER, wet cup, cm100	1														1	1
154	Kit #13/#14	PLUG, pipe, headless	1														1	1

\* Upper shaft seal (106) can not be ordered anymore, please order throat seal (145) instead of it

▲ Replacement safety labels, tags, cards are available at no cost.

✓ Not shown.

<sup>(1)</sup> O-ring kit, 26B924

<sup>(2)</sup> Rod Seals and Piston Kit, 2005346.

<sup>(3)</sup> Inlet Check Kit, 26B927

<sup>(4)</sup> Outlet Check Kit, 26B928

<sup>(5)</sup> Upper Rod Kit, 26B929

<sup>(6)</sup> Lower Rod Kit, 26B930

<sup>(7)</sup> Inlet Shovel Kit, 26B938

<sup>(8)</sup> Inlet Housing Kit, 26D212

<sup>(9)</sup> Outlet Housing Kit, 26D213

<sup>(10)</sup> Cylinder Kit, 26D214

<sup>(11)</sup> O-ring Kit, 2005347

<sup>(12)</sup> Seals Enclosed Wet Cup L100 Kit, 255618

<sup>(13)</sup> Enclosed Wet Cup L100 Kit, 2006252

<sup>(14)</sup> Update, L100CM, A to B Kit, 2005350

# 200 cc Displacement Pump L200CE

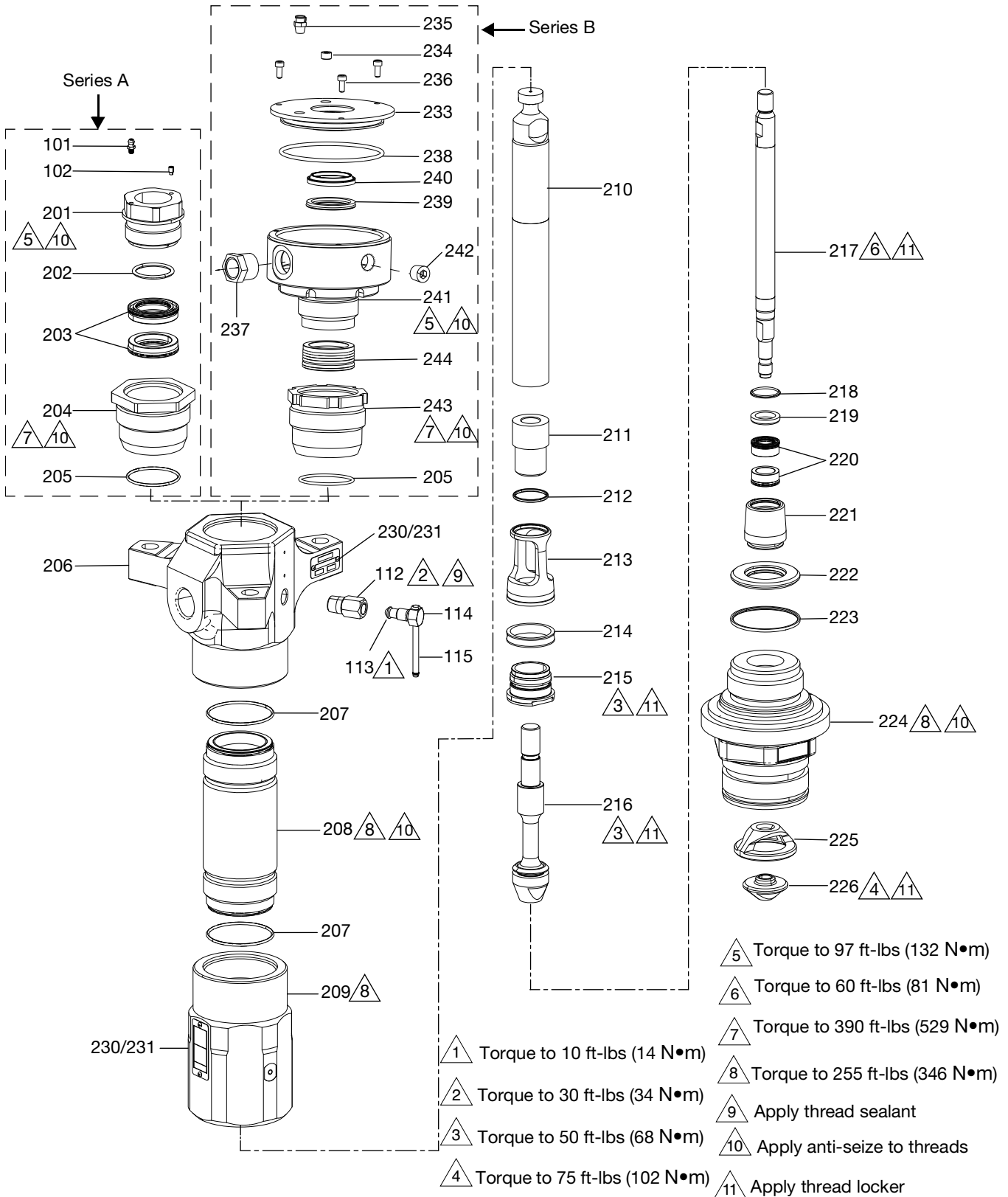



## 200 cc Displacement Pump L200CE Assembly Parts List

Ref.	Kit No. and Part No.	Description	Qty	Kit Number														
				Series A Kit	Series A and B Shared Kits							Series B Kits			Series A to Series B Upgrade Kit			
				Kit #1 26B931 <sup>(1)</sup>	Kit #2 2005348 <sup>(2)</sup>	Kit #3 26B934 <sup>(3)</sup>	Kit #4 26B935 <sup>(4)</sup>	Kit #5 26B936 <sup>(5)</sup>	Kit #6 26B937 <sup>(6)</sup>	Kit #7 255605 <sup>(7)</sup>	Kit #8 255611 <sup>(8)</sup>	Kit #9 26D215 <sup>(9)</sup>	Kit #10 2005349 <sup>(10)</sup>	Kit #11 255619 <sup>(11)</sup>	Kit #12 2006254 <sup>(12)</sup>	Kit #13 2006476 <sup>(13)</sup>	Kit #13 2005351 <sup>(14)</sup>	
101	-----	FITTING, grease, M5	1															
102	-----	SCREW, SHS, EXT tip, M5x8	1															
112	165702	HOUSING, valve	1															
113	190128	PLUG	1															
114	121133	HANDLE, outlet, bleed	1															
115	121134	CLIP, outlet, bleed	1															
201	-----	RETAINER, shaft, sealsCM200,XL	1															
202	Kit #1 108785	PACKING, O-ring	1	1														
203*	-----	SEAL, shaft, upper,CM200,XL	2															
204	----	CARTRIDGE, shaft, seals, CM200,XL	1															
205	Kit #1/#10/#13 166073	PACKING, O-ring	1	1								1				1		
206	Kit #7	HOUSING, outlet	1						1									
207	Kit #1/#7/#9/#10 109499	PACKING, O-ring	2	2					1		2	2						
208	Kit #9	CYLINDER, CM200, WC, ES1	1								1							
209	189442	HOUSING, valve, CM200	1															
210	Kit #5	ROD, displacement, upper	1					1										
211	-----	SPACER, pump, rod, CM200, ES1	1															
212	Kit #10	BEARING, piston, guide, CM200	1									1						
213	15M520	GUIDE, piston, 200	1															
214	Kit #2	SEAL, piston, CM200, XL	1		1													
215	Kit #4	VALVE, check, out, seat, CM200, ES1	1				1											
216	Kit #4	VALVE, check out, poppet, CM200, ES1	1				1											
217	Kit #6	SHAFT, assy, lower, CM200, XL	1						1									
218	Kit #2/#3	RING, retaining, intl, 1-3/16, SS	1		1	1												

Ref.	Kit No. and Part No.	Description	Qty	Kit Number													
				Series A Kit	Series A and B Shared Kits							Series B Kits			Series A to Series B Upgrade Kit		
				Kit #1 26B931 <sup>(1)</sup>	Kit #2 2005348 <sup>(2)</sup>	Kit #3 26B934 <sup>(3)</sup>	Kit #4 26B935 <sup>(4)</sup>	Kit #5 26B936 <sup>(5)</sup>	Kit #6 26B937 <sup>(6)</sup>	Kit #7 255605 <sup>(7)</sup>	Kit #8 255611 <sup>(8)</sup>	Kit #9 26D215 <sup>(9)</sup>	Kit #10 2005349 <sup>(10)</sup>	Kit #11 255619 <sup>(11)</sup>	Kit #12 2006254 <sup>(12)</sup>	Kit #12 2006476 <sup>(13)</sup>	Kit #13 2005351 <sup>(14)</sup>
219	Kit #3	SPACER, seal, lower, CM200, XL	1			1											
220	Kit #2	SEAL, shaft, lower, CM200, XL	2		2												
221	Kit #3	VALVE, check, in, poppet, CM200, ES1	1			1											
222	Kit #3	VALVE, check, in, seat,. CM200, XL	1			1											
223	Kit #1/#7/#8/#10	SEAL, (8,10 cm)	1	1					1	1	1						
224	Kit #8 189447	CYLINDER, intake	1							1							
225	276378	PISTON	1														
226	190241	SEAT, piston	1														
227	All kits 113500	SEALANT, anaerobic, 5 cc pack	1	1	1	1	1	1	1	1	1	1	1	1	1	1	1
228	All Kits	LUBRICANT, anti-seize, 7g pack	1	1	1	1	1	1	1	1	1	1	1	1	1	1	1
229	0553-6	LUBRICANT, synthetic, hi-temp, grease	1														
230	184090 ▲	LABEL, warning	1														
231	100508	SCREW, drive	4														
232	172479 ▲✓	TAG, warning	1														
233	Kit #12/#14	COVER, wet cup, cm200	1										1				1
234	Kit #12/#14	PLUG, pipe, headless	1										1				1
235	Kit #12/#14	COVER, oil hole	1										1				1
236	Kit #12/#14	SCREW, shcs, M5 x 12	3										3				3
237	Kit #12/#14	SIGHTGLASS	1										1				1
238	Kit #/11/#12/#14	PACKING, O-ring	1										1	1			1
239	Kit #/11/#12/#14	SEAL, cm200 wet cup cover	1										1	1			1
240	Kit #/11/#12/#14	WIPER, cm200 wet cup cover	1										1	1			1
241	Kit #12/#14	CUP, cm200/ cm250	1										1				1
242	Kit #12/#14	PLUG, pipe SST	1										1				1
243	Kit #13/#14	NUT, packing, L200CX	1												1		1
244	Kit #2/#14 2003746	THROAT SEAL, vee and u-cup, 200cc	1		1												1

- \* *Upper shaft seal (203) can not be ordered anymore, please order throat seal (244) instead of it*
- ▲ *Replacement safety labels, tags, cards are available at no cost.*
- ✓ *Not shown.*
- (1) *O-ring kit, 26B931*
- (2) *Rod Seals and Piston Kit, 2005348*
- (3) *Inlet Check Kit, 26B934*
- (4) *Outlet Check Kit, 26B935*
- (5) *Upper Rod Kit, 26B936*
- (6) *Lower Rod Kit, 26B937*
- (7) *Outlet L200 / L250 Carbon Kit, 255605*
- (8) *Intake L200 / L250 Carbon Kit, 255611*
- (9) *Cylinder Kit, 26D215*
- (10) *O-ring Kit, 2005349*
- (11) *Seals Enclosed Wet Cup L200 Kit, 255619*
- (12) *Enclosed Wet Cup L200 Kit, 2006254*
- (13) *Nut Kit, 2006476*
- (14) *Update, L200CM, A to B Kit, 2005351*

# 250 cc Displacement Pump L250CE

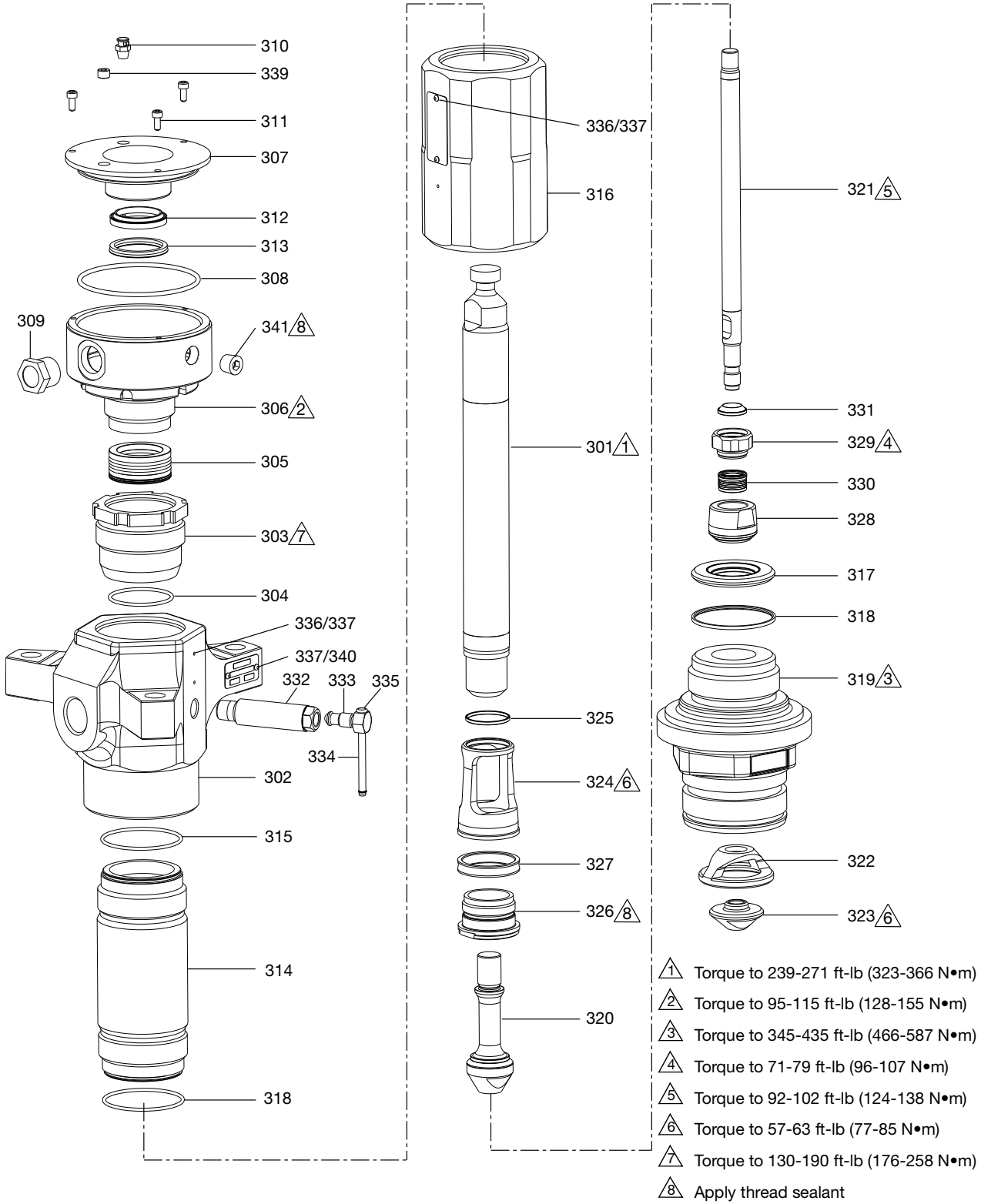

Lubricate all soft seal components before installation.

## 250 cc Displacement Pump L250CE Assembly Parts List

Ref.	Kit No. and Part No.	Description	Qty	Kit Number														
				Kit #1 2006446 <sup>(1)</sup>	Kit #2 2006447 <sup>(2)</sup>	Kit #3 2006448 <sup>(3)</sup>	Kit #4 2006449 <sup>(4)</sup>	Kit #5 2006477 <sup>(5)</sup>	Kit #6 2006478 <sup>(6)</sup>	Kit #7 2006479 <sup>(7)</sup>	Kit #8 2006501 <sup>(8)</sup>	Kit #9 2006502 <sup>(9)</sup>	Kit #10 2006503 <sup>(10)</sup>	Kit #11 2006504 <sup>(11)</sup>	Kit #12 255605 <sup>(12)</sup>	Kit #13 255611 <sup>(13)</sup>	Kit #14 237908 <sup>(14)</sup>	Kit #15 255620 <sup>(15)</sup>
301	Kit #5	UPPER ROD, displacement; ceramic	1					1										
302	----	OUTLET HOUSING	1															
303	Kit #7	Cartridge	1							1								
304	Kit #1/#2/#7	O-RING	1	1	1					1								
305	Kit #2	UPPER SEAL, vee and U-cup, L250CE	1		1													
306	Kit #4	CUP	1				1											
307	Kit #4	COVER, wet cup	1				1											
308	Kit #4/#15	O-RING	1				1											1
309	Kit #4	SIGHTGLASS	1				1											
310	Kit #4	COVER, oil hole	1				1											
311	Kit #4	SCREW, socket hd cap; M5 x 12	3				3											
312	Kit #4/#15	WIPER, wet cup cover	1				1											1
313	Kit #4/#15	SEAL, wet cup cover	1				1											1
314	Kit #8	CYLINDER, pump	1								1							
315	Kit #1/#3/#5/#6/#8/#9/#10/#12	O-RING	2	2		2		2	2		2	2	2		2			
316	190389	HOUSING, valve	1															
317	Kit #10	SEAT, valve	1									1						
318	Kit #1/#3/#5/#6/#8/#10/#12/#13	SEAL	1	1		1		1	1		1			1	1			
319	Kit #13	INTAKE HOUSING	1													1		
320	Kit #9	SEAT, piston	1								1							
321	Kit #6	LOWER ROD	1						1									
322	Kit #11	PISTON	1										1					
323	Kit #11	SEAT, piston	1										1					
324	Kit #9	GUIDE, piston	1								1							
325	Kit #3/#8/#9	BEARING, guide	1			1				1	1							
326	Kit #9	SEAT, piston	1								1							
327	Kit #3/#8/#9	SEAL, piston	1			1				1	1							
328	Kit #10	VALVE, intake	1									1						
329	Kit #10	NUT, packing	1									1						

Parts

Ref.	Kit No. and Part No.	Description	Qty	Kit Number														
				Kit #1 2006446 <sup>(1)</sup>	Kit #2 2006447 <sup>(2)</sup>	Kit #3 2006448 <sup>(3)</sup>	Kit #4 2006449 <sup>(4)</sup>	Kit #5 2006477 <sup>(5)</sup>	Kit #6 2006478 <sup>(6)</sup>	Kit #7 2006479 <sup>(7)</sup>	Kit #8 2006501 <sup>(8)</sup>	Kit #9 2006502 <sup>(9)</sup>	Kit #10 2006503 <sup>(10)</sup>	Kit #11 2006504 <sup>(11)</sup>	Kit #12 255605 <sup>(12)</sup>	Kit #13 255611 <sup>(13)</sup>	Kit #14 237908 <sup>(14)</sup>	Kit #15 255620 <sup>(15)</sup>
330	Kit #3/#10	LOWER SEAL, vee and U-cup, L250CE	1			1							1					
331	Kit #3/#10	SEAL, valve	1			1							1					
332	Kit #14	HOUSING, valve	1														1	
333	Kit #14	PLUG, valve	1														1	
334	Kit #14	HANDLE, outlet bleed	1														1	
335	Kit #14	CLIP, outlet bleed	1														1	
336	Kit #12 184090▲	LABEL, warning	2														2	
337	Kit #12 100508	SCREW, drive	6														6	
338	172479▲✓	TAG, instruction, safety	1															
339	Kit #4	PLUG, pipe	1				1											
340	Kit #12 197561	PLATE, identification	1														1	
341	Kit #4	PLUG, pipe	1				1											

▲ Replacement safety labels, tags, cards are available at no cost.

<sup>(15)</sup> Enclosed Wet Cup Seal Kit, L250CE, 255620

✓ Not shown.

<sup>(1)</sup> O-ring Kit, L250CE, 2006446

<sup>(2)</sup> Throat Seal Kit, L250CE, 2006447

<sup>(3)</sup> Piston and Intake Seal Kit, L250CE, 2006448

<sup>(4)</sup> Enclosed Wet Cup Kit, L250CE, 2006449

<sup>(5)</sup> Upper Rod Kit, L250CE, 2006477

<sup>(6)</sup> Lower Rod Kit, L250CE, 2006478

<sup>(7)</sup> Cartridge Kit, L250CE, 2006479

<sup>(8)</sup> Cylinder Kit, L250CE, 2006501

<sup>(9)</sup> Piston Kit, L250CE, 2006502

<sup>(10)</sup> Intake Valve Kit, L250CE, 2006503

<sup>(11)</sup> Inlet Shovel Kit, L250CE, 2006504

<sup>(12)</sup> Outlet Kit, L250CE, 255605

<sup>(13)</sup> Intake Housing Kit, L250CE, 255611

<sup>(14)</sup> Bleed Valve Kit, 237908

# 500 cc Displacement Pump L500CE

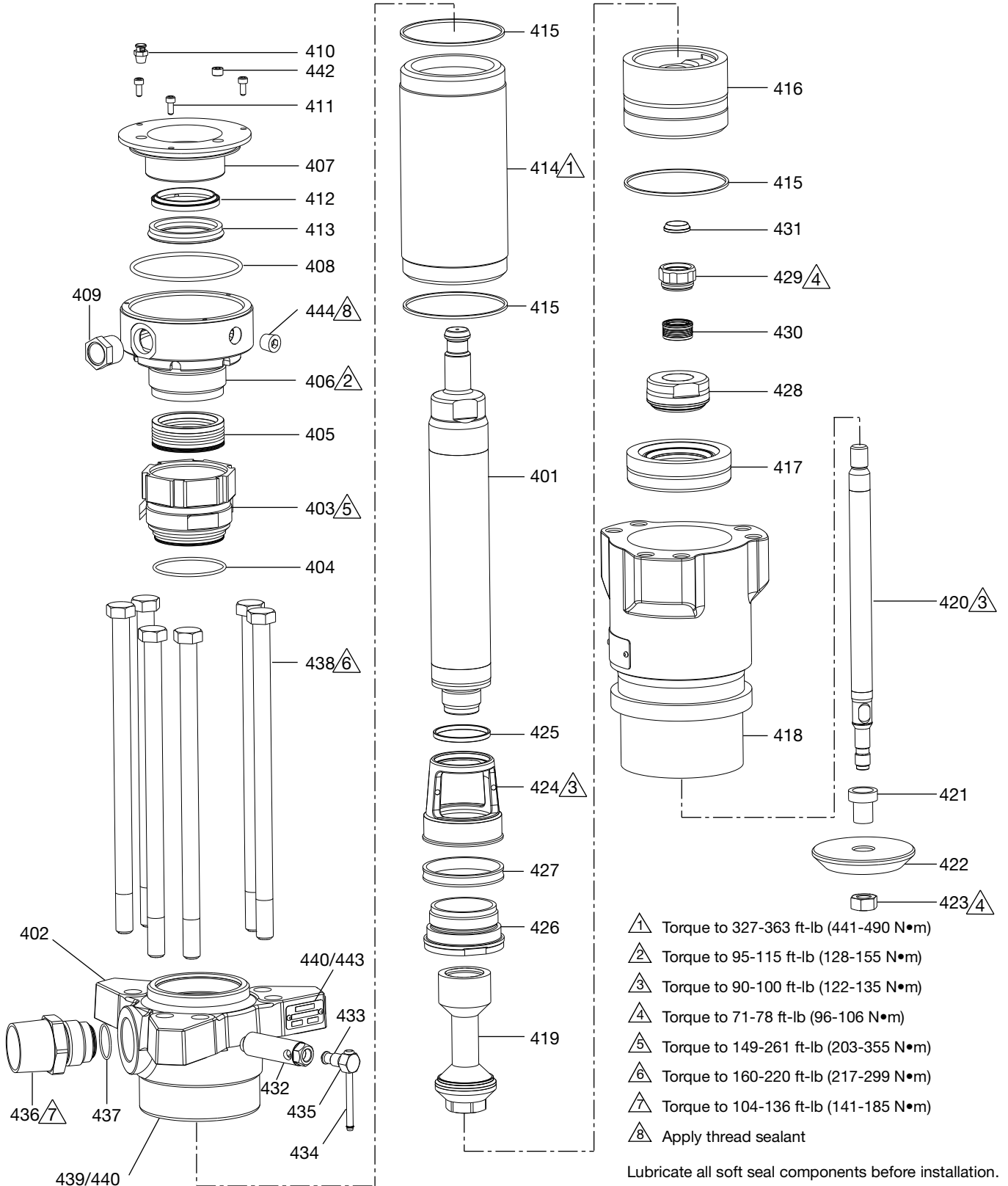

## 500 cc Displacement Pump L500CE Assembly Parts List

Ref.	Kit No. and Part No.	Description	Qty	Kit Number														
				Kit #1 2006505 <sup>(1)</sup>	Kit #2 2006506 <sup>(2)</sup>	Kit #3 2006507 <sup>(3)</sup>	Kit #4 2006508 <sup>(4)</sup>	Kit #5 2006509 <sup>(5)</sup>	Kit #6 2006510 <sup>(6)</sup>	Kit #7 2006511 <sup>(7)</sup>	Kit #8 2006512 <sup>(8)</sup>	Kit #9 2006513 <sup>(9)</sup>	Kit #10 2006514 <sup>(10)</sup>	Kit #11 2006515 <sup>(11)</sup>	Kit #12 255607 <sup>(12)</sup>	Kit #13 255613 <sup>(13)</sup>	Kit #14 237908 <sup>(14)</sup>	Kit #14 255621 <sup>(15)</sup>
401	Kit #1	UPPER ROD, displacement; chrome	1	1														
402	Kit #12	OUTLET HOUSING	1										1					
403	Kit #2	Cartridge	1		1													
404	Kit #2/#9/#11	O-RING	1		1						1	1						
405	Kit #9	UPPER SEAL, vee and U-cup, L500CE	1								1							
406	Kit #3	CUP	1			1												
407	Kit #3	COVER, wet cup	1			1												
408	Kit #3/#15	O-RING	1			1												1
409	Kit #3	SIGHTGLASS	1			1												
410	Kit #3	COVER, oil hole	1			1												
411	Kit #3	SCREW, socket hd cap; M5 x 12	3			3												
412	Kit #3/#15	WIPER, wet cup cover	1			1												1
413	Kit #3/#15	SEAL, wet cup cover	1			1												1
414	Kit #4	CYLINDER, pump	1				1											
415	Kit #1/#4/#5/#6/#7/#10/#11/#12	O-RING	3	3			3	3	3	3		3	3	3				
416	-----	HOUSING, valve	1															
417	Kit #4	SEAT, valve	1				1											
418	Kit #13	INTAKE HOUSING	1												1			
419	Kit #7	SEAT, piston	1						1									
420	Kit #10	LOWER ROD, piston	1								1							
421	Kit #8	GUIDE, piston	1							1								
422	Kit #8	END PISTON	1							1								
423	Kit #8	SEAT, piston	1							1								
424	Kit #7	GUIDE, piston	1						1									
425	Kit #4/#6/#7	BEARING, guide	1			1		1	1									
426	Kit #7	SEAT, piston	1						1									
427	Kit #4/#6/#7	SEAL, piston	1			1		1	1									
428	Kit #5	VALVE, intake	1				1											
429	Kit #5	NUT, packing	1				1											
430	Kit #5/#6	LOWER SEAL, vee and U-cup, L500CE	1				1	1										
431	Kit #5/#6	SEAL, valve	1				1	1										



Ref.	Kit No. and Part No.	Description	Qty	Kit Number																
				Kit #1 2006505 <sup>(1)</sup>	Kit #2 2006506 <sup>(2)</sup>	Kit #3 2006507 <sup>(3)</sup>	Kit #4 2006508 <sup>(4)</sup>	Kit #5 2006509 <sup>(5)</sup>	Kit #6 2006510 <sup>(6)</sup>	Kit #7 2006511 <sup>(7)</sup>	Kit #8 2006512 <sup>(8)</sup>	Kit #9 2006513 <sup>(9)</sup>	Kit #10 2006514 <sup>(10)</sup>	Kit #11 2006515 <sup>(11)</sup>	Kit #12 255607 <sup>(12)</sup>	Kit #13 255613 <sup>(13)</sup>	Kit #14 237908 <sup>(14)</sup>	Kit #14 255621 <sup>(15)</sup>		
432	Kit #14	HOUSING, valve	1																	1
433	Kit #14	PLUG, valve	1																	1
434	Kit #14	HANDLE, outlet bleed	1																	1
435	Kit #14	CLIP, outlet bleed	1																	1
436	184279	FITTING, outlet	1																	
437	Kit #11/#12 109213	SEAL, outlet	1										1	1						
438	109203	BOLT, hex	6																	
439	Kit #12 184293▲	LABEL, warning	1															1		
440	Kit #12 100508	SCREW, drive	6														6			
441	172479▲✓	TAG, instruction, safety	1																	
442	Kit #3	PLUG, pipe	1			1														
443	Kit #12 197561	PLATE, identification	1														1			
444	Kit #3	PLUG, pipe	1			1														

▲ Replacement safety labels, tags, cards are available at no cost. <sup>(15)</sup> Enclosed Wet Cup Seal Kit, L500CE, 255621

✓ Not shown.

<sup>(1)</sup> Upper Rod Kit, L500CE, 2006505

<sup>(2)</sup> Cartridge Kit, L500CE, 2006506

<sup>(3)</sup> Enclosed Wet Cup Kit, L500CE, 2006507

<sup>(4)</sup> Cylinder Kit, L500CE, 2006508

<sup>(5)</sup> Intake Valve Kit, L500CE, 2006509

<sup>(6)</sup> Piston And Intake Seal Kit, L500CE, 2006510

<sup>(7)</sup> Piston Kit, L500CE, 2006511

<sup>(8)</sup> Inlet shovel Kit, L500CE, 2006512

<sup>(9)</sup> Throat Seal Kit, L500CE, 2006513

<sup>(10)</sup> Lower Rod Kit, L500CE, 2006514

<sup>(11)</sup> O-ring Kit, L500CE, 2006515

<sup>(12)</sup> Outlet Kit, L500CE, 255607

<sup>(13)</sup> Intake Housing Kit, L500CE, 255613

<sup>(14)</sup> Bleed Valve Kit, 237908

# Dimensions

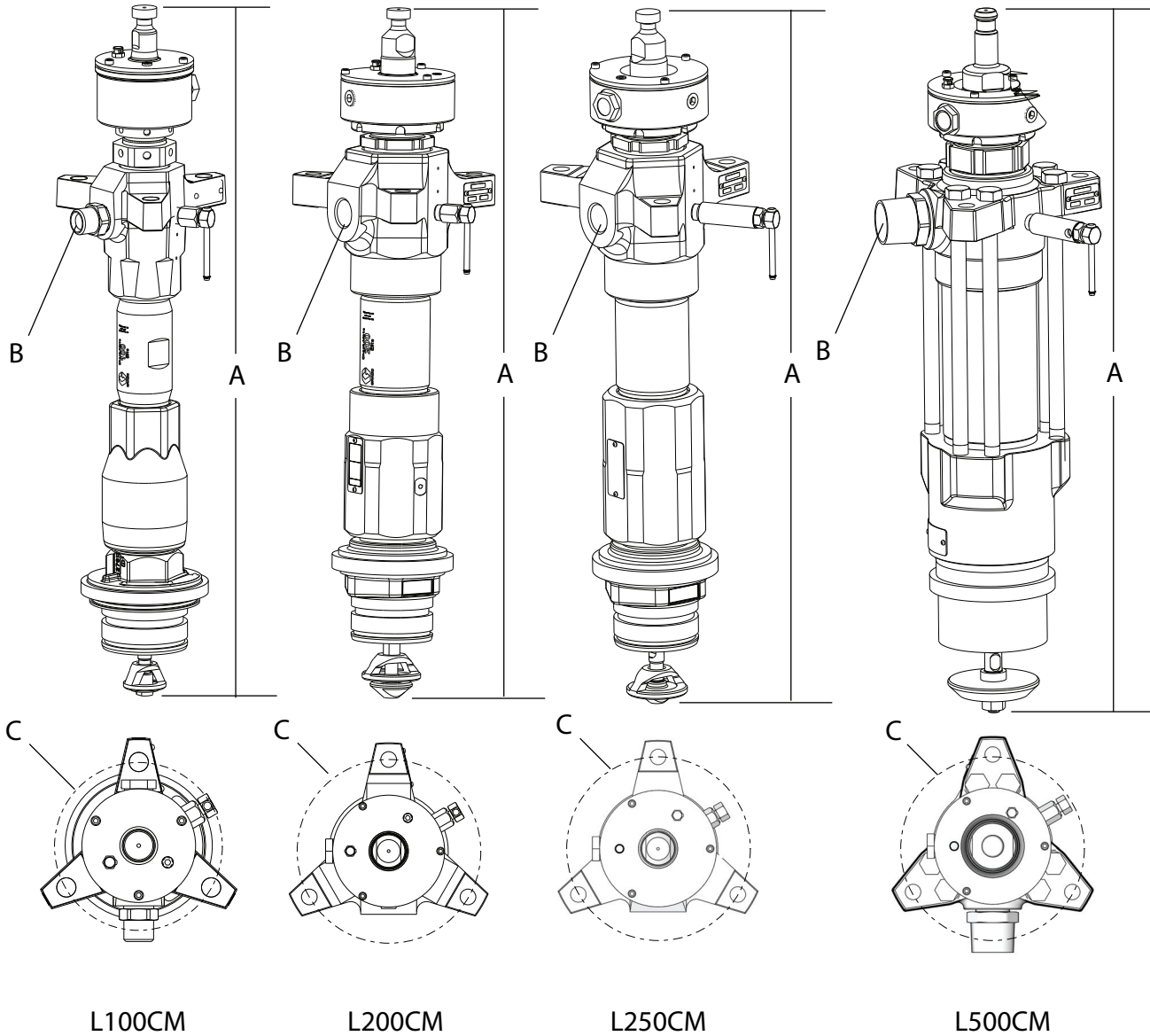

FIG. 47

Displacement Pump	A (Height) in. (mm)	B (Outlet Size) in. npt	C (Outlet Housing Mounting Hole Diameter) in. (mm)
100cc	28.62 (727.0)	3/4 npt(m)	5.91 (150.0)
200cc	29.75 (755.7)	1 npt(f)	8.0 (203.0)
250cc	29.68 (754.0)	1 npt(f)	8.0 (203.0)
500cc	29.88 (759.0)	1-1/2 npt(m)	8.0 (203.0)

# Technical Specifications

<b>Check-Mate® Elite Series Displacement Pumps</b>		
	<b>US</b>	<b>Metric</b>
Maximum operating temperature	180 °F	80 °C
<b>Maximum fluid working pressure</b>		
100cc	4200 psi	28.9 MPa, 289.6 bar
200cc	4200 psi	28.9 MPa, 289.6 bar
250cc	6200 psi	43.4 MPa, 434 bar
500cc	3900 psi	27.3 MPa, 273 bar
<b>Stroke length</b>		
NXT2200, NXT3400, and NXT6500 NXT air motors	4.75 in.	120 mm
<b>Wetted parts</b>		
L100CE / L200CE	304, 316, and 17-4PH grades of stainless steel; PTFE; ductile iron; carbon steel; electroless nickel, zinc; high molecular weight polyethylene; tungsten carbide.	
L250CE	303, 304, 316, 17-4PH, and 440C grades of stainless steel; carbon steel; ductile iron, electroless nickel-coated; zinc, chrome, and electroless nickel plating; UHMWPE; nitrile rubber; PTFE; polyurethane; carbon-filled PTFE; ceramic TZP; tungsten carbide.	
L500CE	303, 304, 316, 17-4PH, and 440C grades of stainless steel; carbon steel, electroless nickel plated and zinc plated; ductile iron, electroless nickel plated; nitrile rubber; PTFE; UHMWPE; polyurethane; carbon-filled PTFE; chrome and electroless nickel plating; ceramic TZP; tungsten carbide.	
<b>Notes</b>		
All trademarks or registered trademarks are the property of their respective owners.		

## California Proposition 65

### CALIFORNIA RESIDENTS

 **WARNING:** Cancer and reproductive harm – [www.P65warnings.ca.gov](http://www.P65warnings.ca.gov).

# Graco Standard Warranty

Graco warrants all equipment referenced in this document which is manufactured by Graco and bearing its name to be free from defects in material and workmanship on the date of sale to the original purchaser for use. With the exception of any special, extended, or limited warranty published by Graco, Graco will, for a period of twelve months from the date of sale, repair or replace any part of the equipment determined by Graco to be defective. This warranty applies only when the equipment is installed, operated and maintained in accordance with Graco's written recommendations.

This warranty does not cover, and Graco shall not be liable for general wear and tear, or any malfunction, damage or wear caused by faulty installation, misapplication, abrasion, corrosion, inadequate or improper maintenance, negligence, accident, tampering, or substitution of non-Graco component parts. Nor shall Graco be liable for malfunction, damage or wear caused by the incompatibility of Graco equipment with structures, accessories, equipment or materials not supplied by Graco, or the improper design, manufacture, installation, operation or maintenance of structures, accessories, equipment or materials not supplied by Graco.

This warranty is conditioned upon the prepaid return of the equipment claimed to be defective to an authorized Graco distributor for verification of the claimed defect. If the claimed defect is verified, Graco will repair or replace free of charge any defective parts. The equipment will be returned to the original purchaser transportation prepaid. If inspection of the equipment does not disclose any defect in material or workmanship, repairs will be made at a reasonable charge, which charges may include the costs of parts, labor, and transportation.

**THIS WARRANTY IS EXCLUSIVE, AND IS IN LIEU OF ANY OTHER WARRANTIES, EXPRESS OR IMPLIED, INCLUDING BUT NOT LIMITED TO WARRANTY OF MERCHANTABILITY OR WARRANTY OF FITNESS FOR A PARTICULAR PURPOSE.**

Graco's sole obligation and buyer's sole remedy for any breach of warranty shall be as set forth above. The buyer agrees that no other remedy (including, but not limited to, incidental or consequential damages for lost profits, lost sales, injury to person or property, or any other incidental or consequential loss) shall be available. Any action for breach of warranty must be brought within two (2) years of the date of sale.

**GRACO MAKES NO WARRANTY, AND DISCLAIMS ALL IMPLIED WARRANTIES OF MERCHANTABILITY AND FITNESS FOR A PARTICULAR PURPOSE, IN CONNECTION WITH ACCESSORIES, EQUIPMENT, MATERIALS OR COMPONENTS SOLD BUT NOT MANUFACTURED BY GRACO.** These items sold, but not manufactured by Graco (such as electric motors, switches, hose, etc.), are subject to the warranty, if any, of their manufacturer. Graco will provide purchaser with reasonable assistance in making any claim for breach of these warranties.

In no event will Graco be liable for indirect, incidental, special or consequential damages resulting from Graco supplying equipment hereunder, or the furnishing, performance, or use of any products or other goods sold hereto, whether due to a breach of contract, breach of warranty, the negligence of Graco, or otherwise.

## **FOR GRACO CANADA CUSTOMERS**

The Parties acknowledge that they have required that the present document, as well as all documents, notices and legal proceedings entered into, given or instituted pursuant hereto or relating directly or indirectly hereto, be drawn up in English. Les parties reconnaissent avoir convenu que la rédaction du présente document sera en Anglais, ainsi que tous documents, avis et procédures judiciaires exécutés, donnés ou intentés, à la suite de ou en rapport, directement ou indirectement, avec les procédures concernées.

# Graco Information Sealant and Adhesive Dispensing Equipment

For the latest information about Graco products, visit [www.graco.com](http://www.graco.com).

For patent information, see [www.graco.com/patents](http://www.graco.com/patents).

**TO PLACE AN ORDER**, contact your Graco distributor, go to [www.graco.com](http://www.graco.com), or call to identify the nearest distributor.

**If calling from the USA:** 1-800-746-1334

**If calling from outside the USA:** 0-1-330-966-3000

*All written and visual data contained in this document reflects the latest product information available at the time of publication. Graco reserves the right to make changes at any time without notice.*

Original instructions. This manual contains English. MM 3A8564D

**Graco Headquarters:** Minneapolis

**International Offices:** Belgium, China, Japan, Korea

**GRACO INC. AND SUBSIDIARIES • P.O. BOX 1441 • MINNEAPOLIS MN 55440-1441 • USA**  
**Copyright 2021, Graco Inc. All Graco manufacturing locations are registered to ISO 9001.**

[www.graco.com](http://www.graco.com)  
Revision D, June 2024