

Axial Dispense[®] Valves

3A8166E

EN

Dispense valves for controlling material flow of adhesives, sealants, and other materials that are compatible with the wetted parts of the valve. For professional use only.

Not approved for use in explosive atmospheres or hazardous (classified) locations.

26B450

Ambient Valve with On-Board Solenoid
4000 psi (27.6 MPa, 276 bar) Maximum Working Pressure
120 psi (0.8 MPa, 8.2 bar) Maximum Air Pressure

26B451

Heated Valve with On-Board Solenoid
4000 psi (27.6 MPa, 276 bar) Maximum Working Pressure
120 psi (0.8 MPa, 8.2 bar) Maximum Air Pressure

26B452

Ambient Valve with Remote Mount Solenoid
4000 psi (27.6 MPa, 276 bar) Maximum Working Pressure
120 psi (0.8 MPa, 8.2 bar) Maximum Air Pressure

26B453

Heated Valve with Remote Mount Solenoid
4000 psi (27.6 MPa, 276 bar) Maximum Working Pressure
120 psi (0.8 MPa, 8.2 bar) Maximum Air Pressure



Important Safety Instructions

Read all warnings and instructions in this manual before using the equipment. Save these instructions.

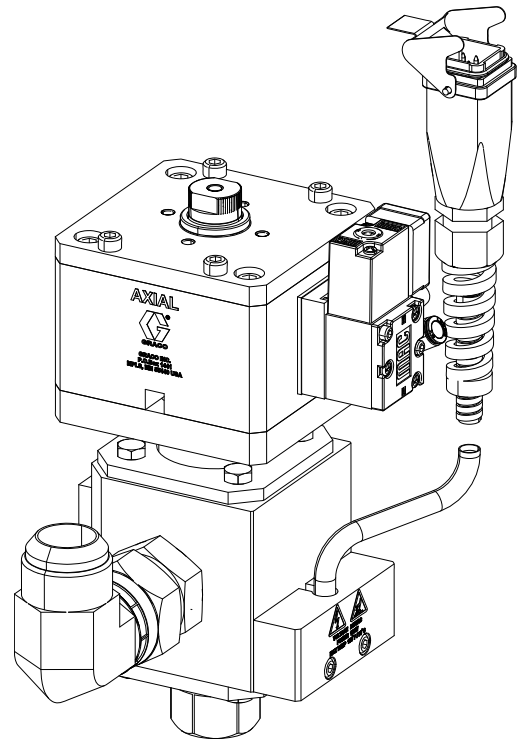







26B451 Shown

Contents







Warnings	3	Accessories	25
Component Identification	6	Pressure Transducer Adapter With O-Ring, 26B457	
Heater Assembly	7	25	
Theory of Operation	8	Nozzle Outlet With O-Rings, 26B475	25
Installation	9	Nozzle Nut, 26B476	25
Grounding	9	Heat Block Spacer, 26B468	25
Flush Before Using Equipment	9	Remote Solenoid Kit, 26B473	25
Install Dispense Valve	9	Transducer Kit, 26B474	26
Adjust Stroke	10	Solenoid Valve Actuation Cable, 25R781	26
Pressure Relief Procedure	11	Solenoid Valve Actuation Cable, 25R799	26
Maintenance	12	Grease Zerk Fitting, 130883	26
Factors Affecting Valve Life	12	Grease Plug, 136249	26
Recycling and Disposal	12	Seal Kit, 26B459	26
End of Product Life	12	Ball Tip Kit, 26B458	27
Troubleshooting	13	Pressure Transducer, 15M669	27
Repair	15	Seat Kit, 26B460	27
Disconnect Air Section	15	Housing Kit, 26B461	27
Connect Air Section	15	Fluid Housing Kit, 26B466	28
Fluid Housing Repair	15	Cylinder Cap Kit, 26B462	28
Replace U-Cup Cartridge, Fluid Housing O-rings,		Valve Rod Kit, 26B463	28
and Ball Assembly	16	Piston Kit, 26B464	28
Air Section Repair	17	Inner Housing Kit, 26B465	28
Replace RTD Sensor and Heater Cartridges ..	19	Heat Cover Kit, 26B469	28
Parts	20	Heat Retrofit Kit, 26B470	29
Air Section	22	V-Notch Nozzle Kit, 26B477	29
Heater Assembly Parts	23	Mounting Kit, 26B471 and 26B472	30
Valve Mounted Solenoid	24	Dimensions and Mounting	31
Valve With Remote Mounted Solenoid	24	Heat Assembly	32
		Wiring Diagrams	33
		Electric Housing Wiring Diagram	33
		Technical Specifications	34
		Axial Valve Torque Chart	35
		California Proposition 65	35
		Graco Standard Warranty	36

Warnings

The following warnings are for the setup, use, grounding, maintenance, and repair of this equipment. The exclamation point symbol alerts you to a general warning and the hazard symbols refer to procedure-specific risks. When these symbols appear in the body of this manual or on warning labels, refer back to these Warnings. Product-specific hazard symbols and warnings not covered in this section may appear throughout the body of this manual where applicable.

 WARNING	
<div style="display: flex; flex-direction: column; gap: 10px;">      </div>	<p>SKIN INJECTION HAZARD</p> <p>High-pressure fluid from dispensing device, hose leaks, or ruptured components will pierce skin. This may look like just a cut, but it is a serious injury that can result in amputation. Get immediate surgical treatment.</p> <ul style="list-style-type: none"> Do not point dispensing device at anyone or at any part of the body. Do not put your hand over the fluid outlet. Do not stop or deflect leaks with your hand, body, glove, or rag. Follow the Pressure Relief Procedure when you stop dispensing and before cleaning, checking, or servicing equipment. Tighten all fluid connections before operating the equipment. Check hoses and couplings daily. Replace worn or damaged parts immediately.
	<p>BURN HAZARD</p> <p>Equipment surfaces and fluid that is heated can become very hot during operation. To avoid severe burns:</p> <ul style="list-style-type: none"> Do not touch hot fluid or equipment.

WARNING

   	<p>FIRE AND EXPLOSION HAZARD</p> <p>Flammable fumes, such as solvent and paint fumes, in work area can ignite or explode. Paint or solvent flowing through the equipment can cause static sparking. To help prevent fire and explosion:</p> <ul style="list-style-type: none"> • Use equipment only in well-ventilated area. • Eliminate all ignition sources; such as pilot lights, cigarettes, portable electric lamps, and plastic drop cloths (potential static sparking). • Ground all equipment in the work area. See Grounding instructions. • Never spray or flush solvent at high pressure. • Keep work area free of debris, including solvent, rags and gasoline. • Do not plug or unplug power cords, or turn power or light switches on or off when flammable fumes are present. • Use only grounded hoses. • Hold gun firmly to side of grounded pail when triggering into pail. Do not use pail liners unless they are anti-static or conductive. • Stop operation immediately if static sparking occurs or you feel a shock. Do not use equipment until you identify and correct the problem. • Keep a working fire extinguisher in the work area.
 	<p>ELECTRIC SHOCK HAZARD</p> <p>This equipment must be grounded. Improper grounding, setup, or usage of the system can cause electric shock.</p> <ul style="list-style-type: none"> • Turn off and disconnect power at main switch before disconnecting any cables and before servicing or installing equipment. • Connect only to grounded power source. • All electrical wiring must be done by a qualified electrician and comply with all local codes and regulations.
	<p>TOXIC FLUID OR FUMES HAZARD</p> <p>Toxic fluids or fumes can cause serious injury or death if splashed in the eyes or on skin, inhaled, or swallowed.</p> <ul style="list-style-type: none"> • Read Safety Data Sheets (SDSs) to know the specific hazards of the fluids you are using. • Store hazardous fluid in approved containers, and dispose of it according to applicable guidelines.

⚠ WARNING



EQUIPMENT MISUSE HAZARD

Misuse can cause death or serious injury.



- Do not operate the unit when fatigued or under the influence of drugs or alcohol.
- Do not exceed the maximum working pressure or temperature rating of the lowest rated system component. See **Technical Specifications** in all equipment manuals.
- Use fluids and solvents that are compatible with equipment wetted parts. See **Technical Specifications** in all equipment manuals. Read fluid and solvent manufacturer's warnings. For complete information about your material, request Safety Data Sheets (SDSs) from distributor or retailer.
- Do not leave the work area while equipment is energized or under pressure.
- Turn off all equipment and follow the **Pressure Relief Procedure** when equipment is not in use.
- Check equipment daily. Repair or replace worn or damaged parts immediately with genuine manufacturer's replacement parts only.
- Do not alter or modify equipment. Alterations or modifications may void agency approvals and create safety hazards.
- Make sure all equipment is rated and approved for the environment in which you are using it.
- Use equipment only for its intended purpose. Call your distributor for information.
- Route hoses and cables away from traffic areas, sharp edges, moving parts, and hot surfaces.
- Do not kink or over bend hoses or use hoses to pull equipment.
- Keep children and animals away from work area.
- Comply with all applicable safety regulations.



PERSONAL PROTECTIVE EQUIPMENT

Wear appropriate protective equipment when in the work area to help prevent serious injury, including eye injury, hearing loss, inhalation of toxic fumes, and burns. Protective equipment includes but is not limited to:

- Protective eyewear, and hearing protection.
- Respirators, protective clothing, and gloves as recommended by the fluid and solvent manufacturer.

Component Identification

Non-Heated Valve

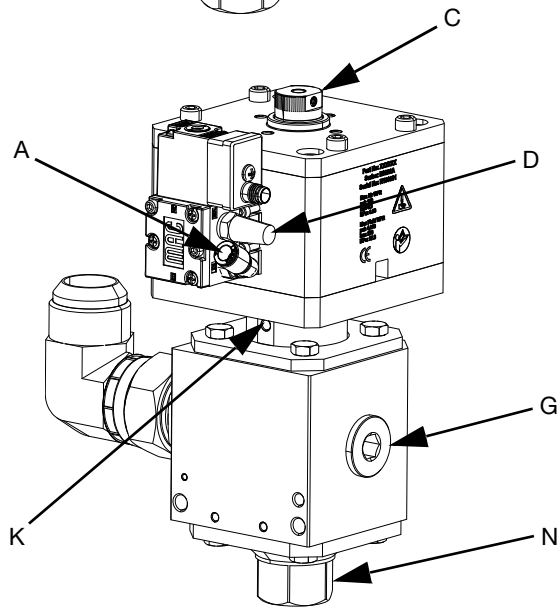
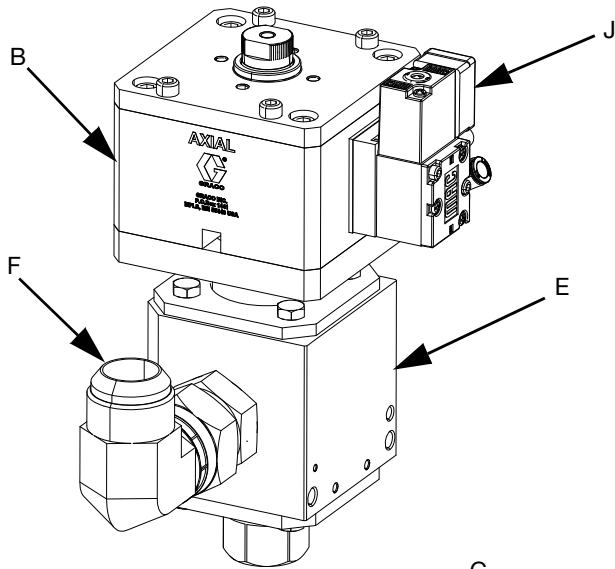

Heated Valve

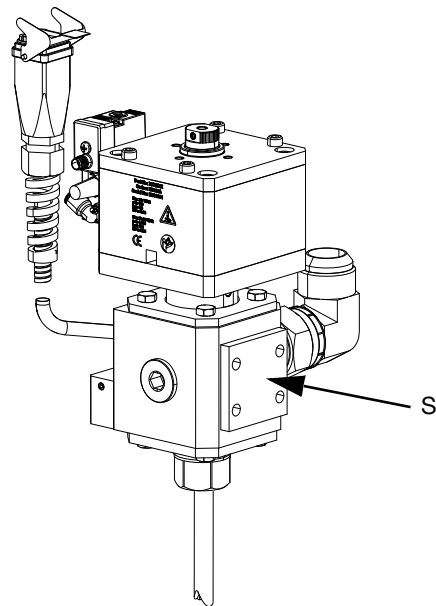
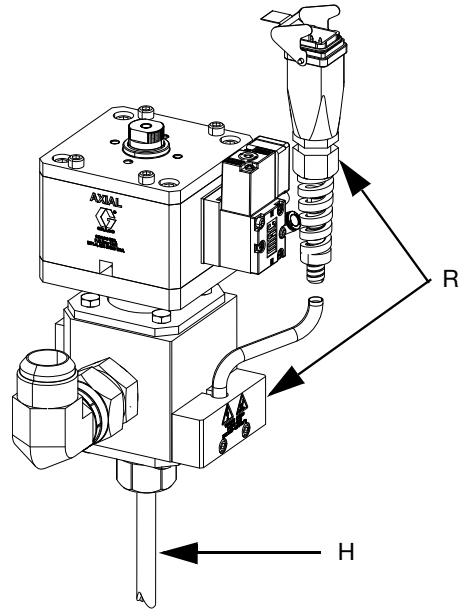

FIG. 1: Axial Dispense Valve

Key:

- A Air Fitting, 1/8" NPT male x 1/4" (6 mm) tube
- B Air Section
- C Adjustment Nut
- D Muffler
- E Fluid Housing
- F 16 JIC Material Inlet Port
- G Optional 7/8-14 SAE Inlet Port

- H Valve Tip
- J Solenoid
- K Weep Hole
- N Outlet Block
- R Heater Assembly
- S Insulator Block

Heater Assembly

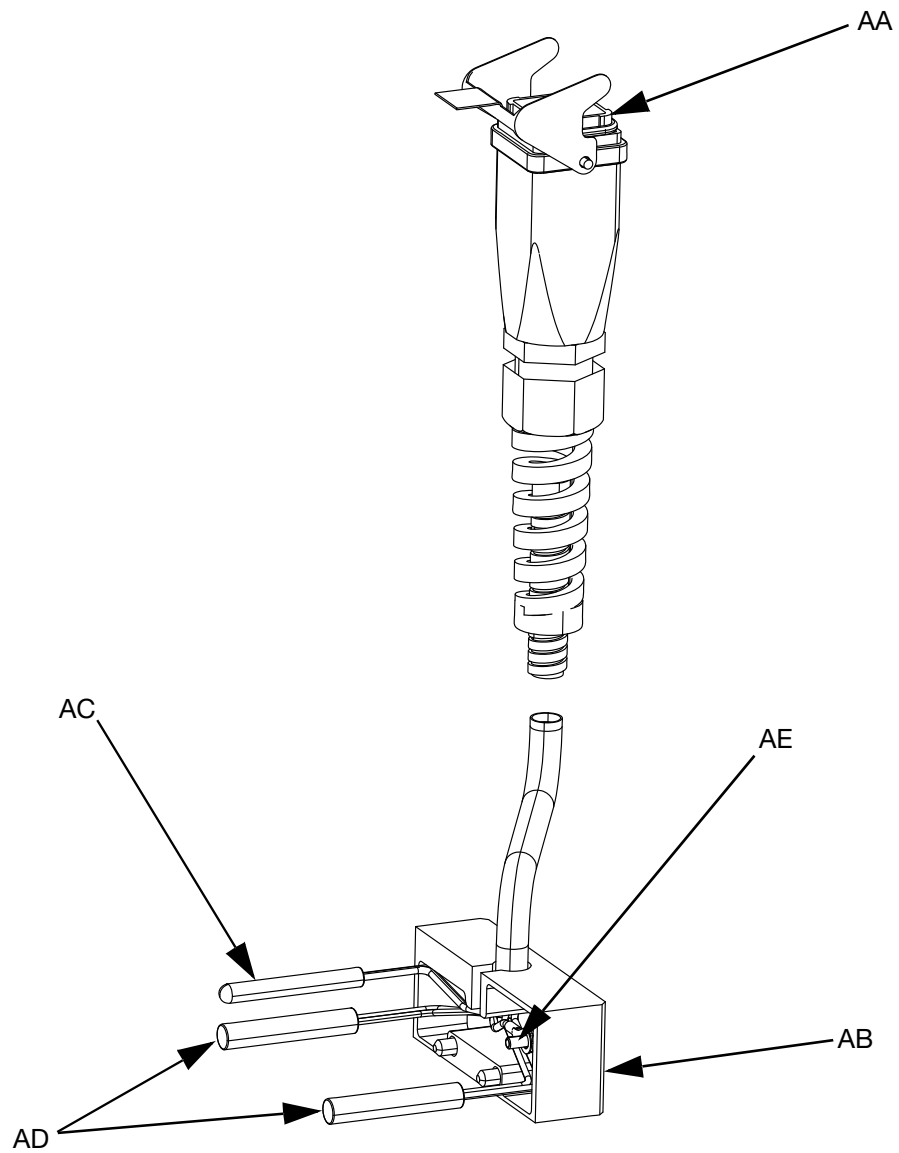

FIG. 2: Heater Assembly

Key:

- AA Wire Harness Connector
- AB Heater Cover
- AC RTD Sensor
- AD Heater Cartridge(s)
- AE Ground Ring Terminal

Theory of Operation

The Axial Dispense Valve uses a four-way exhausting solenoid to control the piston inside the valve. The valve is a forward acting ball-seat valve with a silicon nitride ball sealing against a tungsten carbide seat.

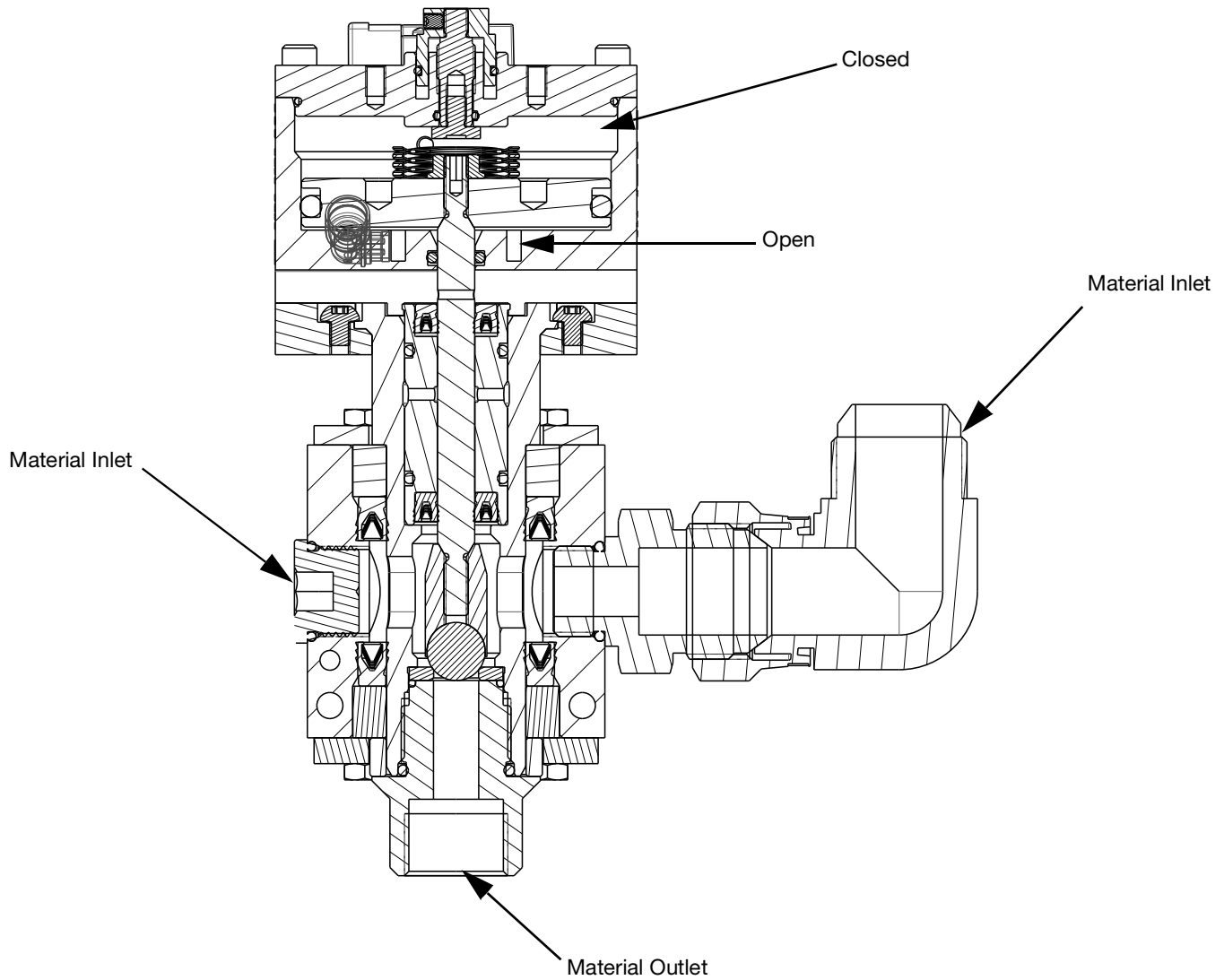

FIG. 3: Theory of Operation

Installation

Grounding



The equipment must be grounded to reduce the risk of static sparking and electric shock. Electric or static sparking can cause fumes to ignite or explode. Improper grounding can cause electric shock. Grounding provides an escape wire for the electric current.

The following grounding instructions are minimum requirements for a basic dispensing system. The specific system being used may include other equipment or objects that must be grounded. Check local electrical codes for detailed grounding instructions.

Dispense valve: ground through a connection to a properly grounded fluid hose and pump. For heated valves, connect the Wire Harness Connector (AA) to the connector on the heated hose. Verify that pin 8 on the heated hose connector is connected to a true earth ground. See **Wiring Diagrams** on page 33.

Pump: see your pump manual.

Fluid hoses: use only electrically conductive hoses with a maximum of 40 ft. (12.2 m) combined hose length to ensure grounding continuity. Check the electrical resistance of the air and fluid hoses at least once a week. If the total resistance to ground exceeds 25 megohms, replace the hose immediately. Use a meter that is capable of measuring resistance at this level.

Fluid supply container: follow local code.

Solvent pails used when flushing: follow local codes and regulations. Use only conductive metal pails, placed on a grounded surface. Do not place the pail on a non-conductive surface, such as paper or cardboard, which interrupts grounding continuity.

To maintain grounding continuity when flushing or relieving pressure: hold metal part of the dispense valve firmly to the side of a grounded metal pail, then trigger the valve.

Flush Before Using Equipment

The equipment was tested with lightweight mineral oil, which is left in the fluid passages to protect parts. To avoid contaminating your fluid with oil, flush the equipment with a compatible solvent before using the equipment.

Install Dispense Valve

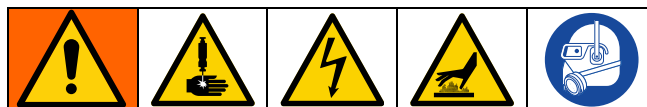

The dispense valves have multiple mounting hole configurations. See **Dimensions and Mounting** on page 31. See **Technical Specifications** on page 34.

1. Inspect the dispense valve for shipping damage. If there is damage, notify the shipping carrier immediately.
2. Install compatible accessories. For a list of accessories and installation instructions, see **Accessories** on page 25.
3. Securely attach the dispense valve to its mounting fixture using socket head cap screws.
4. Connect air lines to the dispense valve:

NOTICE

Only use air fittings that are rated at a temperature equal to or higher than the operating temperature of the fluid dispensing system. Lower rated air fittings could melt and cause damage to the dispense valve.

- a. For valves with a Solenoid (J) mounted to the Air Section (B), connect the air supply tube to the Air Fitting (A). See FIG. 1 on page 6.

Installation

- b. For valves with a remote mounted Solenoid (J), connect the air open line to port 2, and connect the air closed line to port 1. See FIG. 4.
5. Connect the fluid line to the JIC Port (F) in the valve body.
6. For heated valves, connect the Wire Harness Connector (AA) to the heated hose receptacle.
7. For heated valves, install the insulator block between the housing and mounting surface.

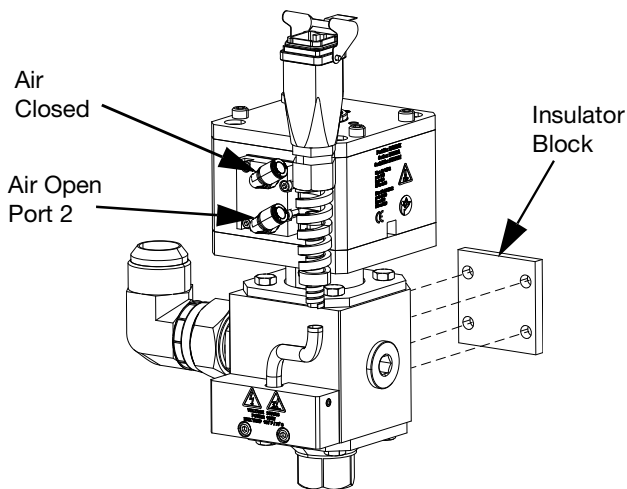

FIG. 4

Adjust Stroke

The Adjustment Nut (C) on the top of the valve can adjust the distance the dispense valve will open. This restricts the flow of material through the tip and seat. See FIG. 5.

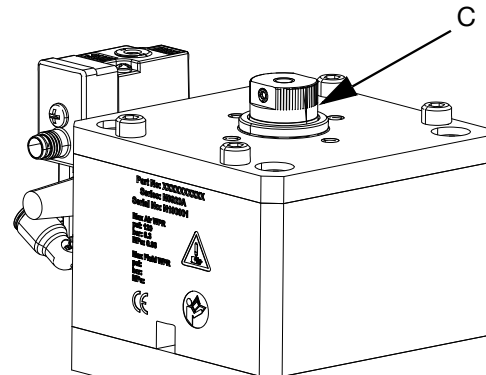

FIG. 5

1. Turn the Adjustment Nut (C) clockwise until the valve is held closed. See FIG. 5.
2. Slowly open the Adjustment Nut (C) and then cycle the air pressure until the desired flow is reached.

Pressure Relief Procedure



Follow the Pressure Relief Procedure whenever you see this symbol.



This equipment stays pressurized until pressure is manually relieved. To help prevent serious injury from pressurized fluid, such as skin injection and splashing fluid, follow the Pressure Relief Procedure when you stop spraying and before cleaning, checking, or servicing the equipment.

This procedure describes how to relieve pressure from the dispense valve. See your supply system manual for instructions on relieving pressure from the entire system.

1. Shut off the material supply.
2. Actuate the dispense valve into a grounded metal waste container to relieve the fluid pressure.
3. Relieve all air pressure in the air lines by shutting off the bleed-type air valve.
4. If heated, shut off electrical power to the dispense valve.
5. If the valve tip or fluid hose is clogged or if pressure has not been fully relieved after following the steps above, **VERY SLOWLY** loosen the SAE inlet fitting from the applicator fluid body or hose end coupling to relieve pressure gradually, then loosen completely. Clear the hose or tip obstruction.

Maintenance

Inspect the dispense valve, material, and air lines at least once every two weeks. Inspect for leakage and other visible damage.

The following tables list recommended maintenance procedures and frequencies. The maintenance is divided between mechanical and electrical tasks. A typical application is a valve mounted on a robot dispensing a moderately abrasive sealant.

Table 1: Mechanical

Task	Weekly	Monthly or 100,000 cycles
Inspect for leaks	✓	
*Check hoses for wear	✓	
*Check/tighten fluid connections		✓
*Check/tighten air connections		✓
Check stroke adjustment	✓	
Lubricate packings		✓

* Assumes movement from automation.

Table 2: Electrical

Task	Weekly	Monthly
Check cables for wear	✓	
Verify cable connections	✓	
Verify resistance of electric heaters		✓
Verify resistance of RTD sensors		✓

Factors Affecting Valve Life

The maintenance tables should be used as a guideline for the frequency of maintenance tasks. Additional factors that could affect valve life include the following:

- **Process Fluid** - Abrasive or fiber filled fluids are much harder on seals, shafts, and seats than non-abrasive fluids such as oil.
- **Number of cycles** - This has a much greater affect on valve wear than number of gallons. If you can do the same job with fewer on/off cycles, the valve will last longer.
- **Air pressure** - This is what provides the force to hold the needle against the seat to seal against fluid pressure.

Recycling and Disposal

End of Product Life

At the end of the product's useful life, dismantle and recycle it in a responsible manner

Troubleshooting

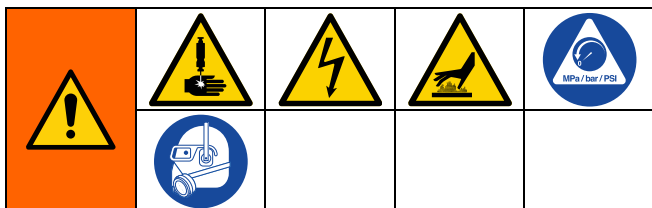

1. Follow the **Pressure Relief Procedure**, page 11, before servicing or repairing the valve.

Problem	Cause	Solution
Air leaks from dispense valve.	Worn gasket.	Replace gasket.
	Loose or worn air connections.	Tighten air connections.
	Worn o-rings.	Replace o-rings in Air Section (B).
	Loose end cap screws.	Tighten screws.
Material leaks from front of dispense valve.	Seal, tip, or seat is worn.	Replace seat seals, tip, and/or seat.
		Check and replace tip, if necessary. If replacing needle, you must reverse or replace seat.
	Obstruction inside dispense valve.	Check and replace or reverse seat if necessary.
Material leaks from dispense valve weep hole.	Seals not installed correctly.	Remove nose piece. Check and replace if necessary, cartridge, tip, and seat.
	Seals are worn.	
Dispense valve does not shut off.	Loose air connections or air supply turned off.	Check cartridge seals and replace cartridge and rod.
	Worn ball-seat interface.	Tighten air connections.
	Broken piston, debris in air cylinder, or debris inside the fluid section (ball-seat and tip seal valves only).	Replace cartridge, tip, and seat.
	Spring broken or not installed correctly.	Disassemble dispense valve. Check and replace, if necessary, piston, piston rod, and o-rings.
Dispense valve does not open or dispense material.	Loose air connections or air supply turned off.	Disassemble dispense valve. Check spring and replace, if necessary.
	Broken rod, piston, or tip. Debris or cured material inside fluid section.	Tighten air connections.
		Disassemble dispense valve. Check and replace, if necessary, piston, piston rod, and o-rings.

Problem	Cause	Solution
Dispense valve does not heat material.	Loose heater wires.	Check and reconnect wire connections.
	Loose sensor wires.	Check and reconnect wire connections.
	Heater unit failed.	Replace cable assembly.
	Sensor failed.	
	No power to heating circuitry.	Apply power to heating circuitry.

Repair

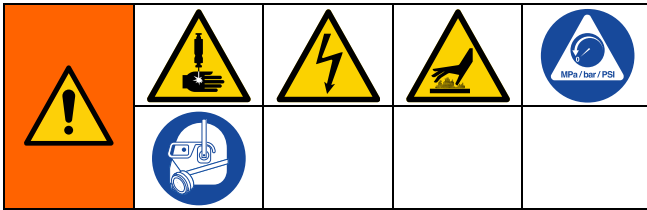

Perform the following procedure before servicing the dispense valve.

1. Perform the **Pressure Relief Procedure** on page 11.
2. For heated valves, shut off electrical power to the dispense valve and disconnect the Wire Harness Connector (AA).
3. Allow the valve to cool completely before servicing.

Disconnect Air Section

1. Follow steps 1 and 3 above.
2. Shut off electrical power to the dispense valve.
3. Disconnect the air lines from the valve.
4. If the Fluid Housing (E) is not mounted, place the Fluid Housing in a vise.
5. Remove the bottom nut (201) from the bottom of the Fluid Housing (E) to disconnect the Air Section (B) from the Fluid Housing (E).

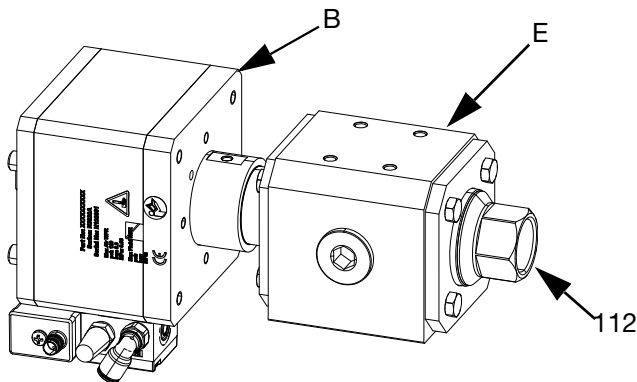

FIG. 6

NOTE: O-rings in the Fluid Housing (E) may stick to the u-cup cartridge, requiring more force to separate the Fluid and Air Sections (E, B).

6. If necessary, replace the Air Section (B) with an assembled Air Section with rod, u-cup cartridge, and tip.

Connect Air Section

1. Slide the assembled Air Section (B), with piston rod, u-cup cartridge, and ball assembly, into the top of the Fluid Housing (E).
2. Torque the outlet nozzle fitting (112) to 54-60 in.-lbs (6.1-6.8 N•m).
3. Connect the air lines.

NOTE: Ensure the air fittings and fluid inlet are in the desired position relative to one another.

Fluid Housing Repair

The u-cup cartridge, fluid section o-rings, and seat seal can be replaced without disconnecting the valve body from the mounting equipment, or material hoses.

Only rebuild the Fluid Housing when fluid weeps out the Weep Hole (K). To rebuild the Fluid Housing, see **Replace U-Cup Cartridge, Fluid Housing O-rings, and Ball Assembly** on page 16 and **Air Section Repair** on page 17.

NOTE: Always replace o-rings after the Fluid Housing has been disassembled.

Replace U-Cup Cartridge, Fluid Housing O-rings, and Ball Assembly

Disassembly

1. Perform the **Pressure Relief Procedure** on page 11.
2. Follow the steps to **Disconnect Air Section** on page 15.
3. If the Fluid Housing (E) is not mounted, place the Fluid Housing in a vise.
4. Place an Allen key or rod into the hole to keep the piston rod (210) from rotating. Remove the ball assembly (217) with a 1/2 in. or 13 mm wrench.

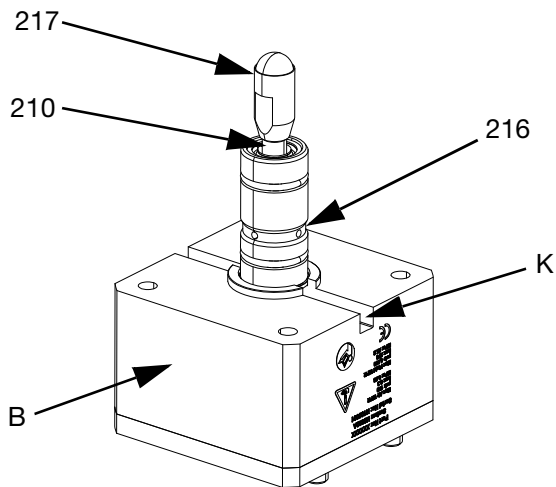

Fig. 7

5. Remove the u-cup cartridge (216) by sliding the cartridge off the shaft.
6. Inspect the piston rod (210) and ball assembly (217) for damage to rings, grooves, or pitting. Replace either if worn.

Assembly

1. Install the new cartridge kit (216) on the piston rod with the flange against the Air Section (B).

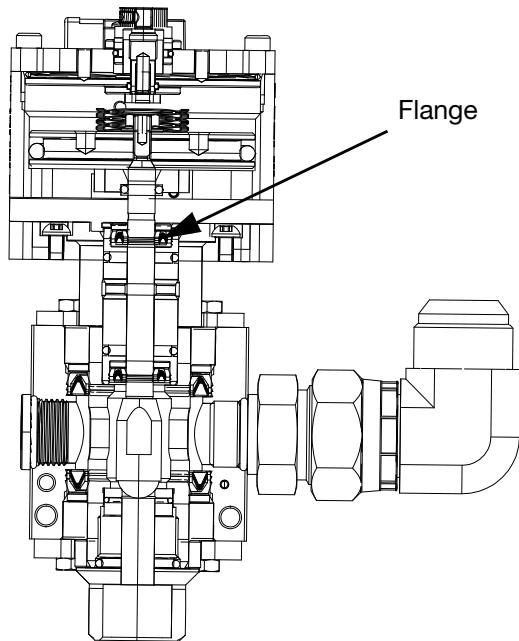

FIG. 8

2. Apply grease on the outside of the cartridge kit (216).
3. Apply a light amount of the supplied purple anaerobic adhesive to the bottom threads of the piston rod (210).
4. Screw the ball assembly (217) on the piston rod (210).
5. Place the valve in a vertical position in a vise. Place an Allen key through the piston rod (210) located in the Weep Hole (K). See FIG. 7.
6. Use a small torque wrench with a 1/2 in. or 13 mm crowfoot to tighten the ball assembly (217) to the piston rod (210). Torque to 54-60 in-lbs (6.1-6.8 N•m).
7. Follow the steps to **Connect Air Section** on page 15.

Air Section Repair

Follow the steps below if a noticeable air leak is detected in the Air Section (B).

Disassembly

1. To repair the Air Section (B), you must remove the ball assembly. Complete the disassembly procedure to **Replace U-Cup Cartridge, Fluid Housing O-rings, and Ball Assembly** on page 16.
2. Remove four screws (202).
3. Remove the air end cap (204), piston rod assembly, and spring (207) from the Air Section (B).

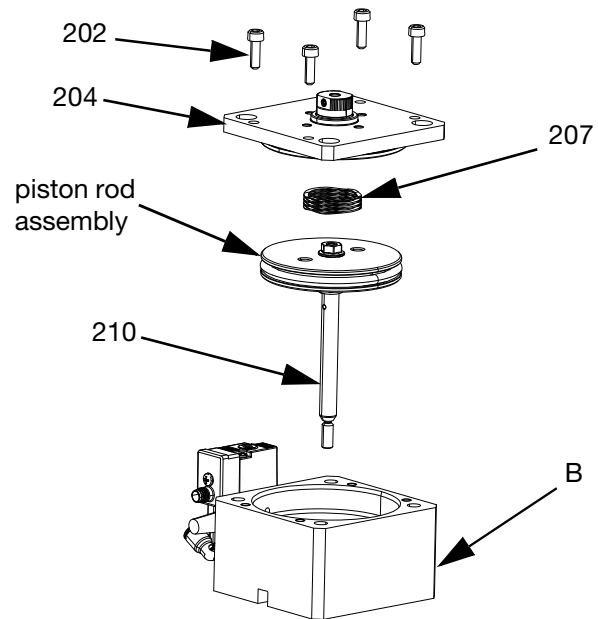

FIG. 9

4. Use a clean cloth to remove all material inside the Air Section (B). Inspect for damage such as scoring marks.

5. Place an Allen key through the hole in the piston rod (210), or place a 3 mm Allen key in the end of the piston rod, and unthread the nut (214) using a 10 mm socket or wrench.

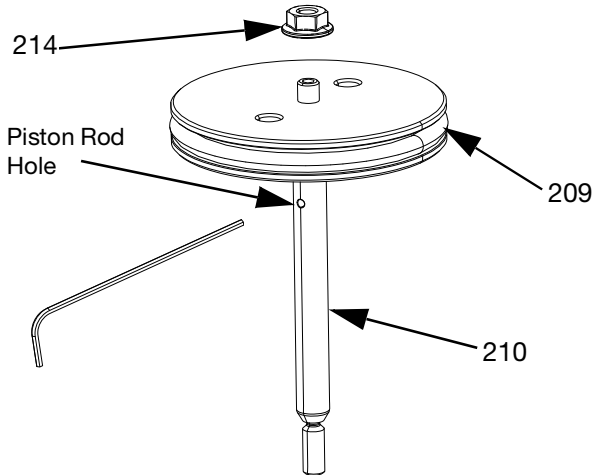

FIG. 10

6. Unthread the piston rod (210) from the piston (209).
7. Inspect the piston (209) and piston rod (210) for damage. Replace if necessary.
8. Unthread the adjuster stop (213) and unthread the knob assembly (212).

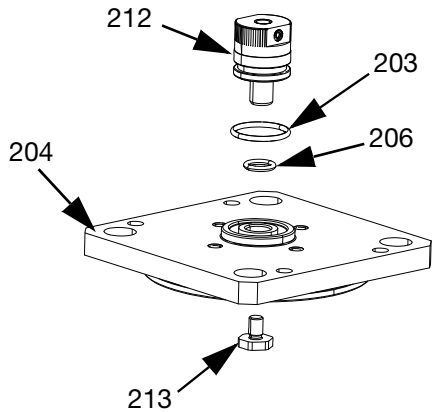

FIG. 11

Assembly

1. To assemble the air cylinder cap (204) on valves with ball-seat or tip seal assemblies:
 - a. Install the o-ring (203) on the knob assembly (212). Place the o-ring (206) in the air cylinder cap (204). See FIG. 11.
 - b. Grease the o-ring (203) on the knob assembly (212) and screw it into the air cylinder cap (204). See FIG. 11.
 - c. Apply the supplied blue anaerobic adhesive to the adjuster stop threads (213) and screw it into the knob assembly (212). Torque to 11-13 in-lbs (1.25-1.5 N•m). See FIG. 11.
2. To assemble the Air Section (B):
 - a. Replace the piston o-ring (208) if it is scratched, cut, or worn. See FIG. 12.
 - b. Place the spring (207) on the top of the piston (209). See FIG. 12.
 - c. Replace the air cylinder cap (204) and insert the screws (202). Press down on the air cylinder cap (204) to compress the spring (207). Torque to 30-36 in-lbs (3.4-4.1 N•m).

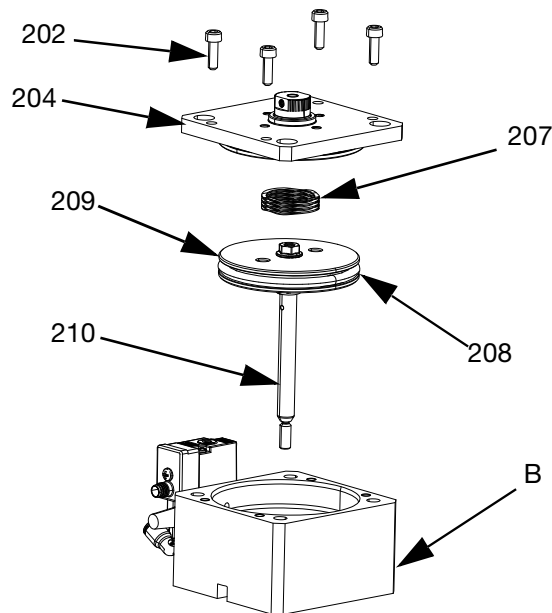

FIG. 12

Replace RTD Sensor and Heater Cartridges



All electrical wiring must be done by a qualified electrician and comply with all local codes and regulations.

1. Follow the **Pressure Relief Procedure** on page 11.
2. Remove the two socket head screws (132) and loosen the set screw (131).
3. Lift the metal conduit up from the heat cover (130). Remove the heater cover (130).
4. Remove the ground screw (129) and star washer (128).
5. Remove the harness (126) by sliding the heater cartridge and RTD out of the heater block.
6. Replace the harness (126) with a new harness assembly.
7. Coat the heater cartridge and RTD with thermal grease compound.
8. Slide the heater cartridge and RTD into the heater block.
9. Replace the ground wire, heater cover, and mounting screws.

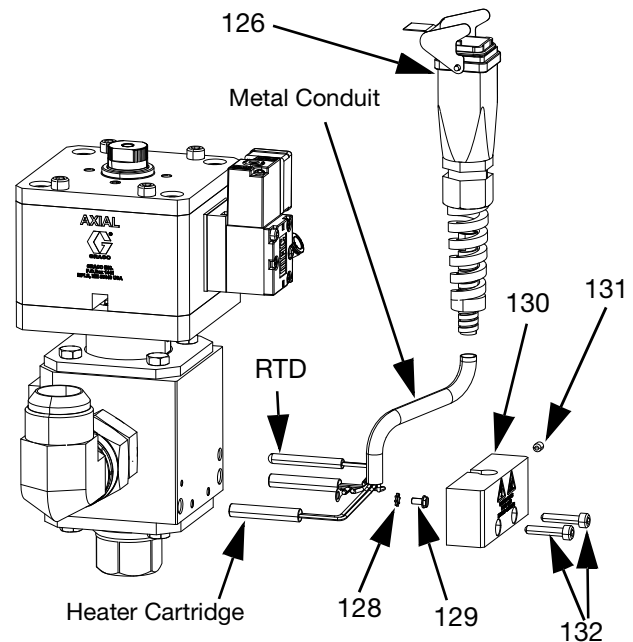

FIG. 13: Heater Assembly for 0 mm Outlet Block

Parts

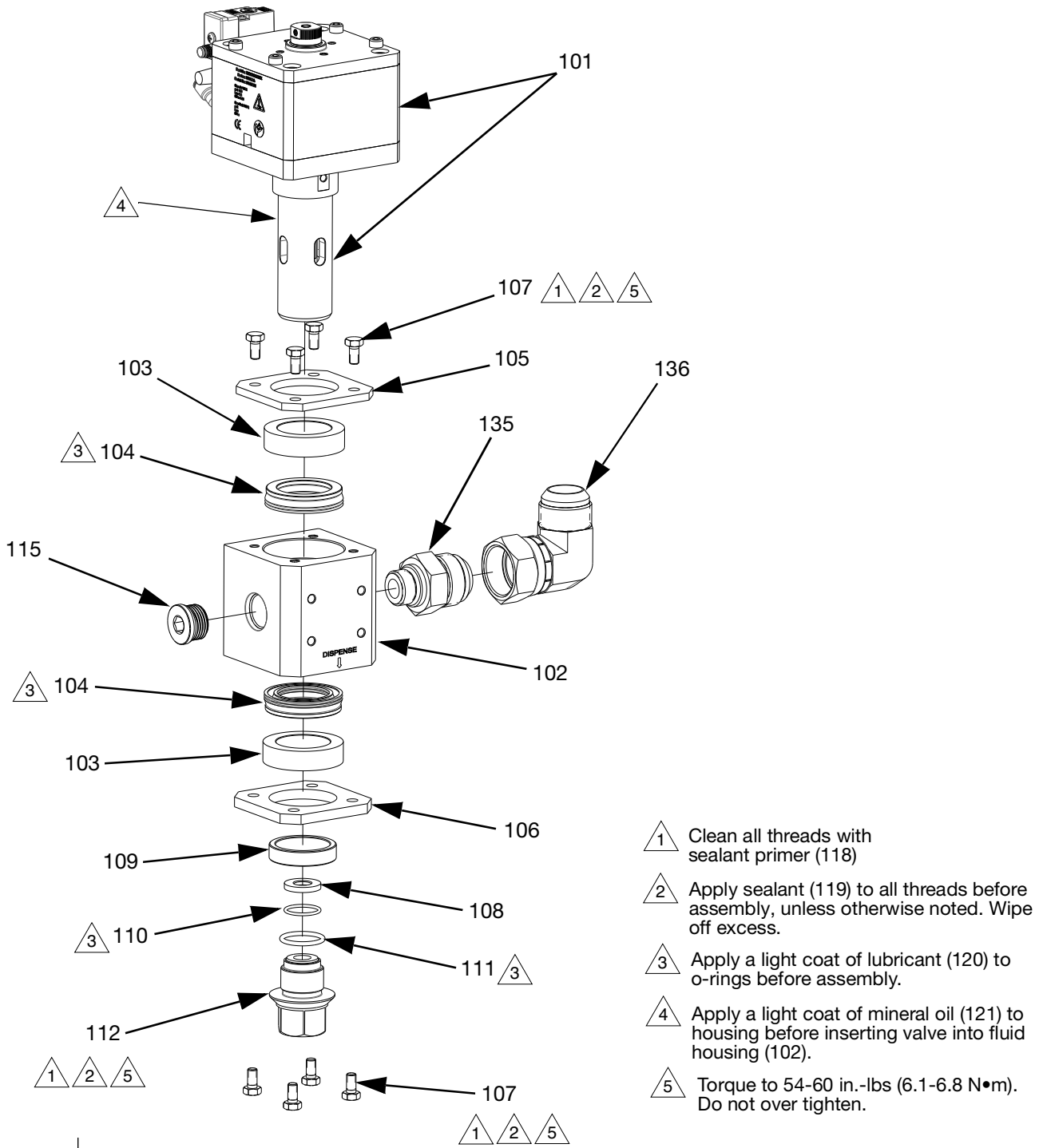

FIG. 14

Axial Dispense Valve

Ref.	Part	Description	Qty.
101	See Air Section on page 22	VALVE, 38, axial	1
102	26B466	KIT, housing, fluid, axial	1
103	18D054	BEARING, housing, inner	2
104	16W014	SEAL, piston/throat, 140 pump	2
105	---	CAP, retainer, axial, top	1
106	---	CAP, retainer, axial, bottom	1
107	133085	SCREW, HHC	8
108*	---	SEAT, carbide	1
109	18D056	SPACER, nozzle, axial	1
110*	---	O-RING, PTFE	1
111*	C20111	O-RING, FKM	1
112	26B475	KIT, nozzle, outlet, index, axial (includes C20111)	1
113❖	110939	SCREW, set, shc	1
114❖	130883	FITTING, grease	1
115	556424	PLUG, pipe stl rd	1
119❖	113500	SEALANT, anaerobic, blue	1
120❖	---	LUBRICANT, grease, hi-temp	1
126◆	See Heater Assembly Parts on page 23	HARNESS, heat, axial	1
127◆		KIT, block, heat, axial	1
128◆		WASHER, lock	1
129◆		SCREW, ground	1
130◆		COVER, heater, axial	1
131◆		SCREW, set, cup	1
132◆		SCREW, shc	2
134❖◆	---	LUBRICANT, thermal	1
135	133091	ADAPTER	1
136	133092	FITTING, elbow	1
137	61/2904-B U/11	TUBE	10
138†❖	555683	O-RING	1
139❖	26B477	KIT, nozzle, vnotch	1
140	26B476	KIT, nut, nozzle, index, axial	1

* Included in kit 26B460.

† Included in kit 26B477.

◆ For 26B451 and 26B453 models only.

❖ Not shown.

NOTE: See page 26 for kit information.

Air Section

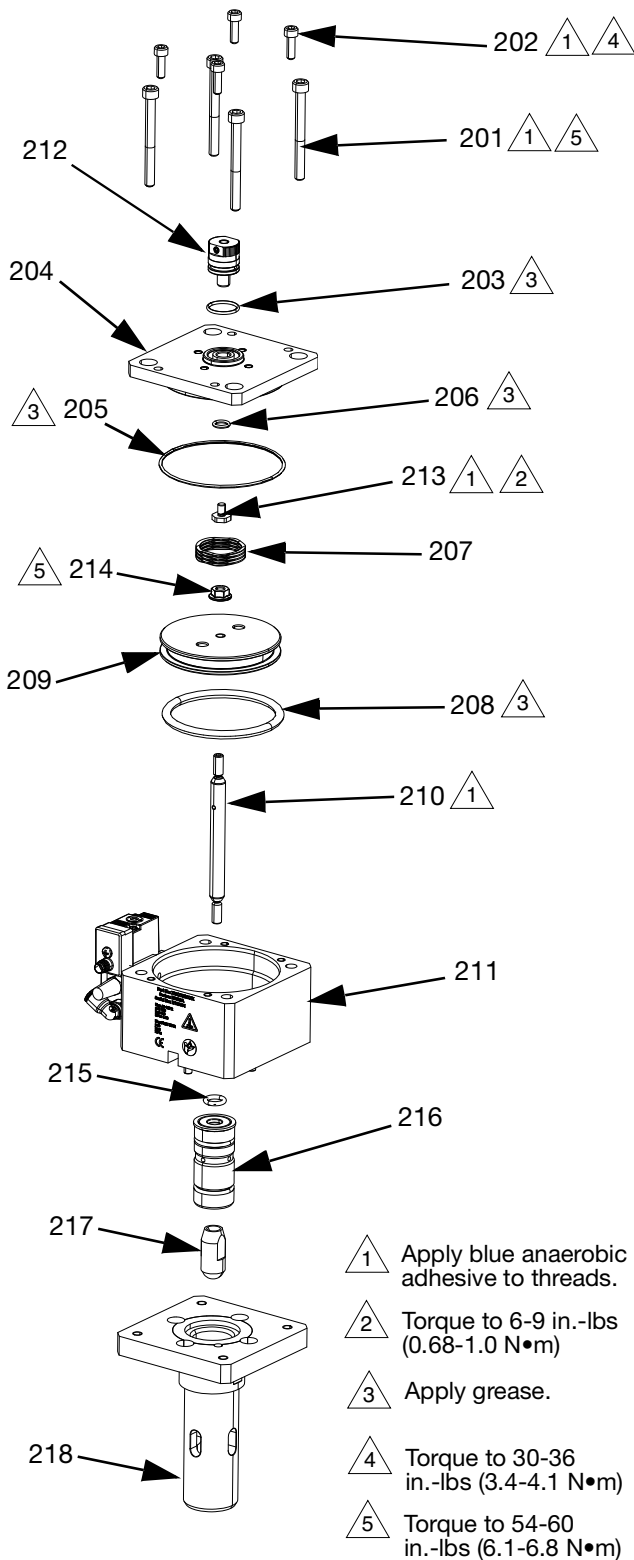

Air Section

Ref.	Part	Description	Qty.
201	112675	SCREW, shc, M6	4
202	117126	SCREW, shc, M5	4
203	108284	O-RING, buna	1
204	26B462	KIT, cap, air cylinder, axial	1
205	120932	O-RING, FKM	1
206	154741	O-RING, buna	1
207	130186	SPRING, wave	1
208	160258	O-RING, buna	1
209	26B464	KIT, piston, axial	1
210	26B463	KIT, rod, valve, plated, axial	1
211	26B461	KIT, housing, cylinder, air, axial	1
212	25B031	KNOB, cap, 1/4", forward	1
213	18B389	STOP, adj, 1/4"	1
214	15U698	NUT, flange, M6	1
215	122529	O-RING (included in kit 26B461)	1
216	26B459	CARTRIDGE, seal, axial	1
217	26B458	KIT, tip, ball, axial	1
218	26B465	HOUSING, inner, axial	1
220	113500	SEALANT, anaerobic, blue	1
221	---	LUBRICANT, grease, high temperature	1

FIG. 15

Heater Assembly Parts

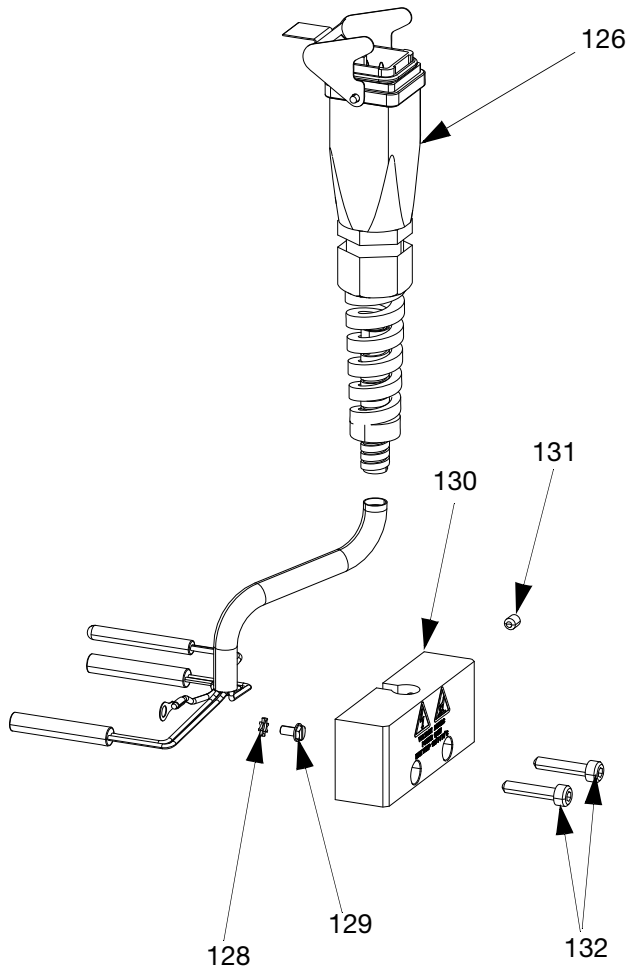

FIG. 16

Ref.	Part	Description	Qty.
126	18D079	HARNESS, heat, axial	1
127*	26B468	KIT, block, heat, axial	1
128	112505	WASHER, lock	1
129	112506	SCREW, ground	1
130	26B469	COVER, heater	1
131	124736	SCREW, set, cup, M4	1
132	116474	SCREW, shcs, m4 x 20	2

* Not shown.

Valve Mounted Solenoid

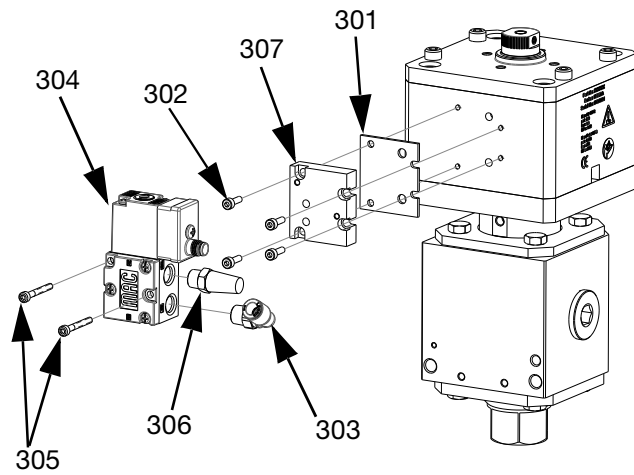

FIG. 17

Ref.	Part	Description	Qty.
301	130866	GASKET, solenoid, 1/4	1
302	130181	SCREW, shcs	4
303	597151	ELBOW, male, swivel	1
304	25V520	SOLENOID, face mount, 24VDC, 12W	1
305	133367	SCREW, shcs	2
306	C06061	MUFFLER, sintered, dia 1/8	1
307	---	BLOCK, solenoid	1

Valve With Remote Mounted Solenoid

NOTE: Solenoid shown in **Remote Solenoid Kit, 26B473** page 25.

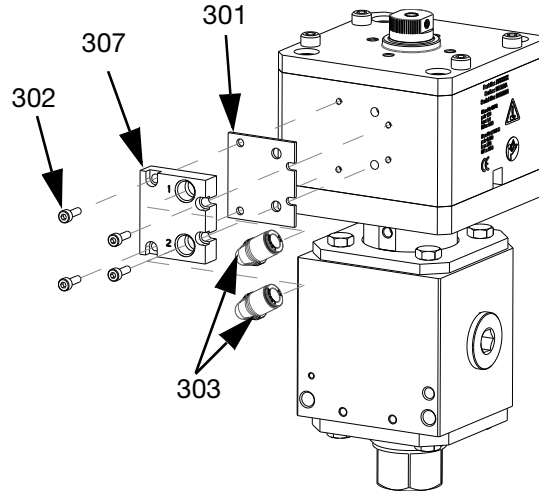

FIG. 18

Ref.	Part	Description	Qty.
301	130866	GASKET, solenoid, 1/4	1
302	130181	SCREW, shcs	4
303	597151	ELBOW, male, swivel	2
307	---	BLOCK, remote	1

Accessories

Before installing any accessories, follow steps 1 through 3 from **Repair** on page 15.

Pressure Transducer Adapter With O-Ring, 26B457

4000 psi (28 MPa, 276 bar) Maximum Working Pressure. 7/8-14 SAE fitting to thread into additional inlet port. Use with 15M669 Pressure Transducer.

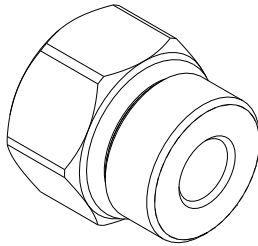

FIG. 19

Nozzle Outlet With O-Rings, 26B475

This is the main retaining nut for the valves, as well as the retainer for the seat. See **Parts** on page 20.

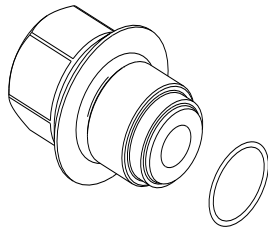

FIG. 20

Nozzle Nut, 26B476

This is the nut that retains the dispense nozzle of the valve.

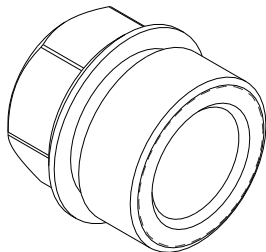

FIG. 21

Heat Block Spacer, 26B468

Use with heated valves to isolate heat.

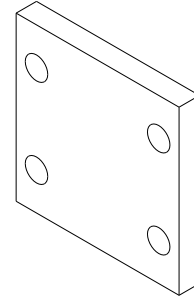

FIG. 22

Remote Solenoid Kit, 26B473

120 psi (0.83 MPa, 8.3 bar) Maximum Working Pressure

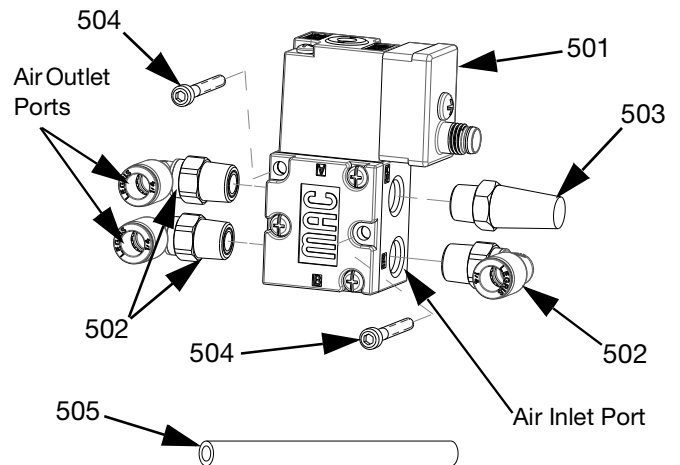

FIG. 23

Ref.	Part	Description	Qty.
501	25V521	SOLENOID, 1/8 NPT, 24VDC, 12W	1
502	597151	FITTING, elbow	3
503	C06061	MUFFLER, sintered, dia 1/8	1
504	133367	SCREW, shcs	2
505	61/2904-BU/11	TUBE	10 ft

Inlet Port Size	Outlet Port Size	Electrical Connector Style	Voltage	Solenoid Power
1/8 in. NPT(f)	1/8 in. NPT(f)	M8 2-pin male	24 VDC	12W

Transducer Kit, 26B474

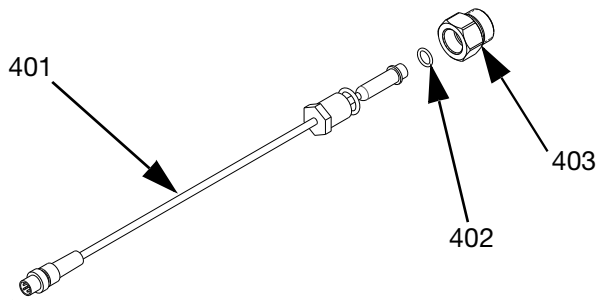

FIG. 24

Ref.	Part	Description	Qty.
401	15M669	SENSOR, pressure, fluid outlet	1
402	111457	PACKING, o-ring	1
403	26B457	ADAPTER, transducer	1

Solenoid Valve Actuation Cable, 25R781

M8-4 pin male straight connector x M8-4 pin female 90° connector, 15.7 in. (0.4 m) cable length.

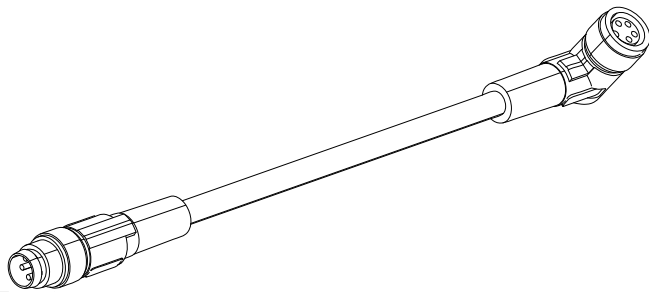

FIG. 25

Solenoid Valve Actuation Cable, 25R799

Accessory cable used to actuate the valve when the valve is connected to customer supplied controls.

M8 - 4 pin female 90° connector x free leads, 393 in. (10.0 m) cable length.

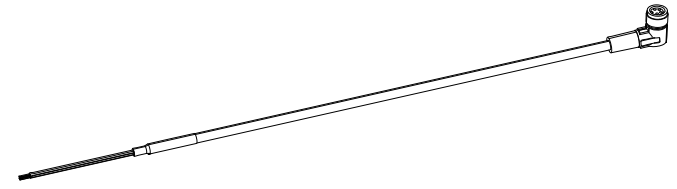

FIG. 26

Grease Zerk Fitting, 130883 Grease Plug, 136249

For applications dispensing moisture sensitive materials, install the Grease Zerk Fitting (M) into the Fluid Housing (E), fill the grease port with grease, and install the Grease Plug (L).

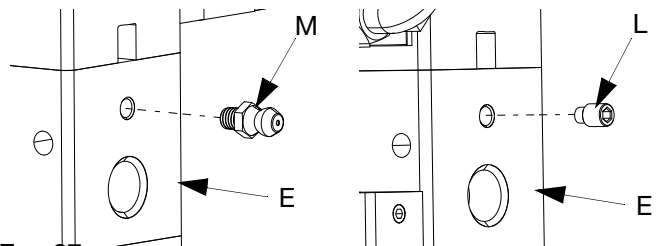

FIG. 27

Seal Kit, 26B459

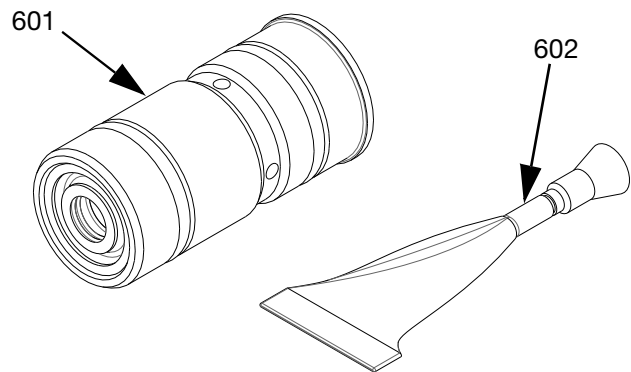

FIG. 28

Ref.	Part	Description	Qty.
601	---	CARTRIDGE, ucups, axial	1
602	122960	ADHESIVE	1

Ball Tip Kit, 26B458

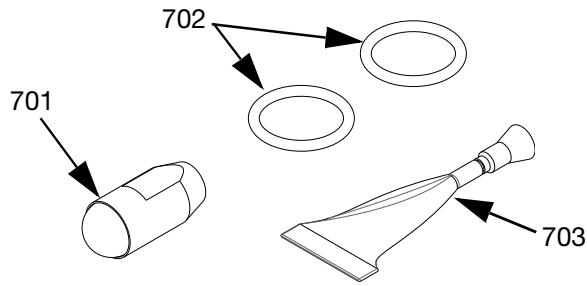

FIG. 29

Ref.	Part	Description	Qty.
701	---	BALL, assembly, crimp, axial	1
702	C20317	PACKING, o-ring	2
703	122960	ADHESIVE	1

Pressure Transducer, 15M669

Use to monitor the fluid outlet pressure in the valve. Requires a pressure transducer adapter for 1/4 in. valves.

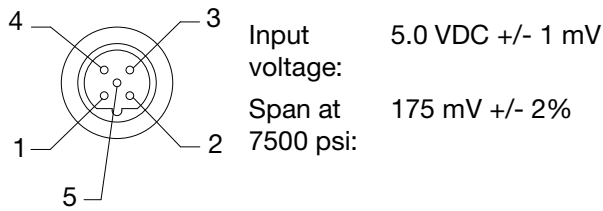

FIG. 30

M12 Pinout Details	
Pin	Description
1	+ Excitation (5 VDC)
2	- Signal
3	- Excitation (COM)
4	+ Signal
5	Shield Drain

Seat Kit, 26B460

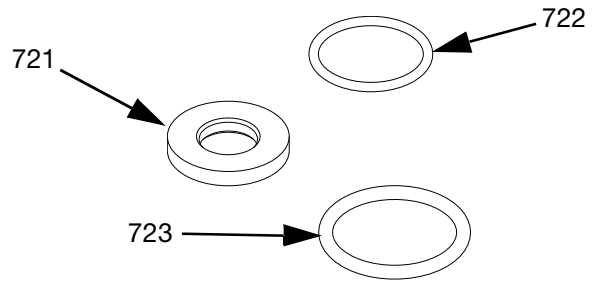

FIG. 31

Ref.	Part	Description	Qty.
721	---	SEAT, carbide	1
722	---	O-RING	1
723	C20111	PACKING, o-ring	1

Housing Kit, 26B461

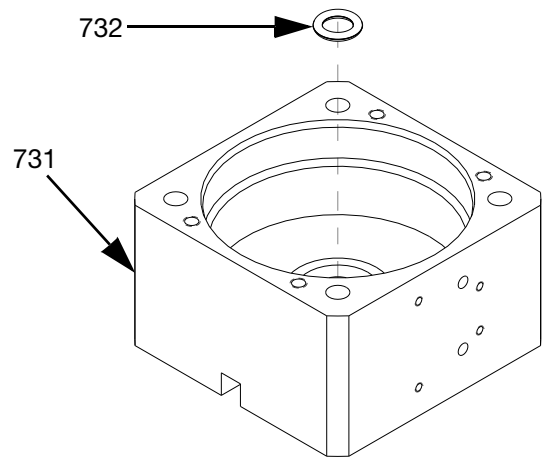

FIG. 32

Ref.	Part	Description	Qty.
731	---	HOUSING, cylinder, air, axial	1
732	122529	O-RING, packing	1

Fluid Housing Kit, 26B466

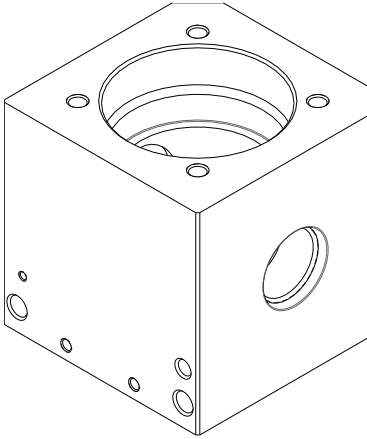

FIG. 33

Cylinder Cap Kit, 26B462

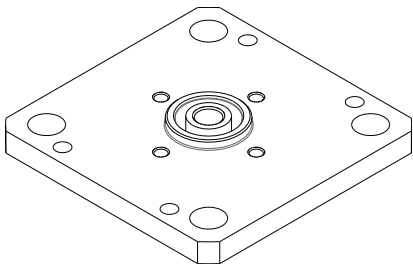

FIG. 34

Valve Rod Kit, 26B463

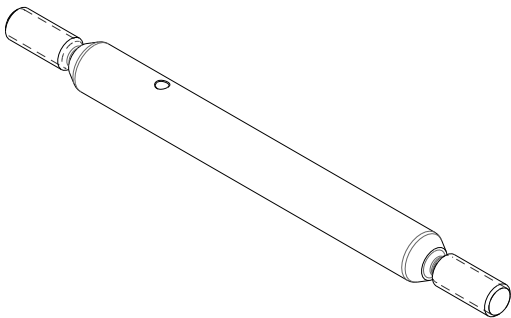

FIG. 35

Piston Kit, 26B464

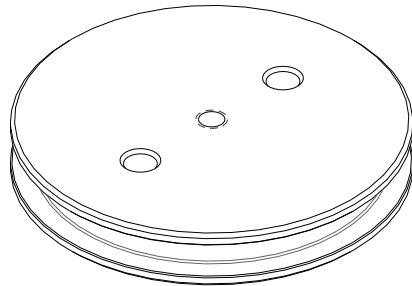

FIG. 36

Inner Housing Kit, 26B465

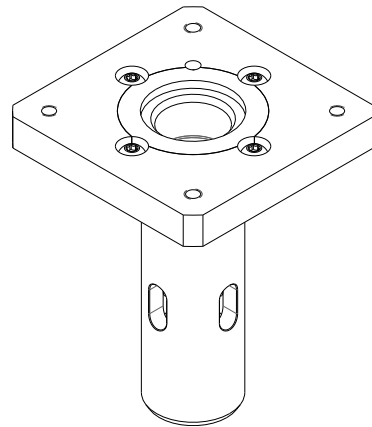

FIG. 37

Heat Cover Kit, 26B469

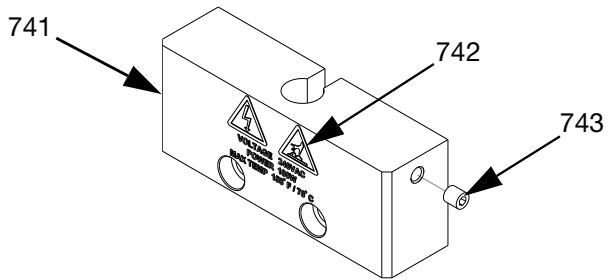

FIG. 38

Ref.	Part	Description	Qty.
741	---	COVER, heater, axial	1
742	---	ARTWORK, heat/shock	1
743	124736	SCREW, set, cup	1

Heat Retrofit Kit, 26B470

See **Replace RTD Sensor and Heater Cartridges** on page 19 for installation instructions.

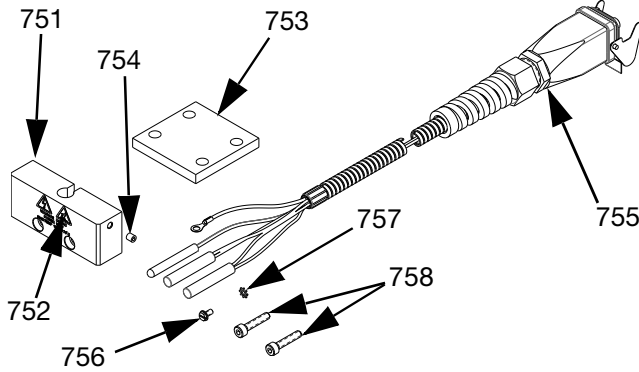

FIG. 39

Ref.	Part	Description	Qty.
751	---	COVER, heater, axial	1
752	---	ARTWORK, heat/shock	1
753	---	BLOCK, heat, valve, axial	1
754	124736	SCREW, set, cup	1
755	18D079	HARNESS, heat, axial	1
756	112506	SCREW, ground	1
757	112505	WASHER, lock	1
758	116474	SCREW, shcs	2

V-Notch Nozzle Kit, 26B477

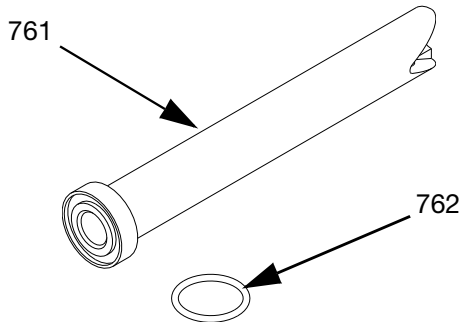

FIG. 40

Ref.	Part	Description	Qty.
761	---	NOZZLE, axial, v-notch	1
762	555683	O-RING	1

Mounting Kit, 26B471 and 26B472

For use with Fanuc M-710IC/50 robots.

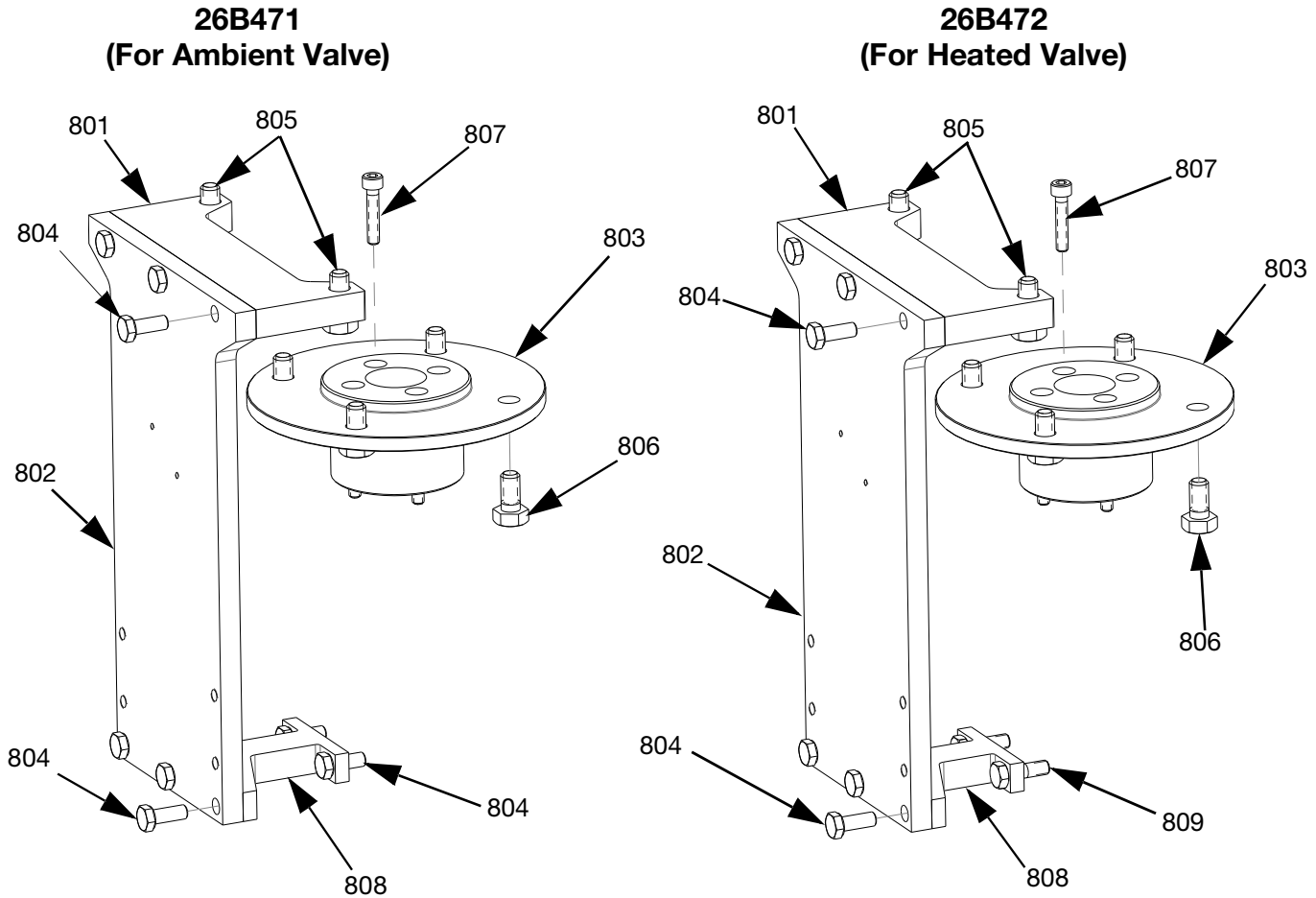
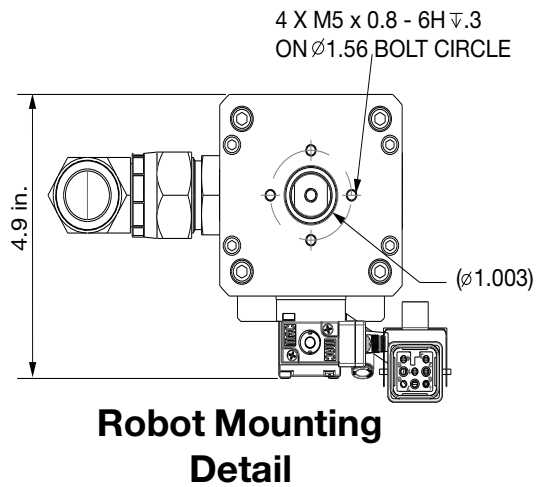
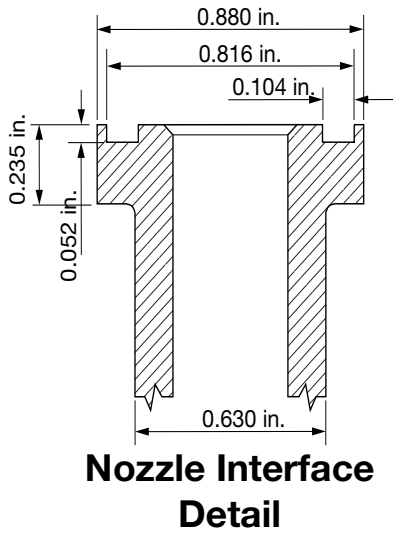
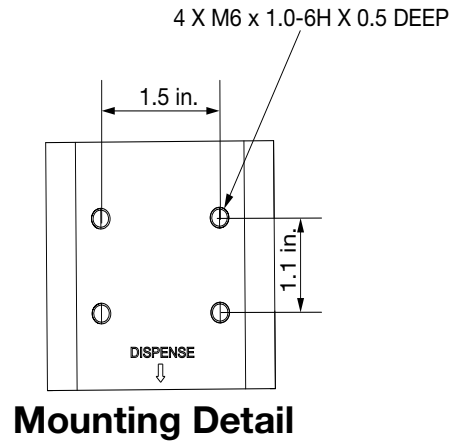
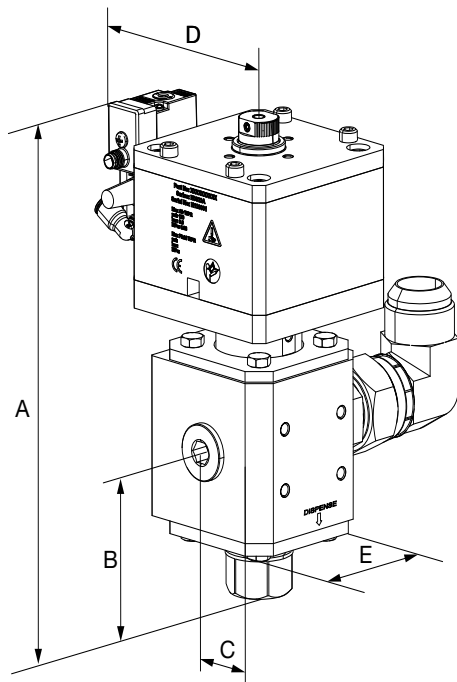

FIG. 41

Ref.	Part	Description	Qty.
801	---	BRACKET, axial, wrist, robot	1
802	---	PLATE, mounting, axial, vertical, robot	1
803	---	ADAPTER, axis, valve, robot	1
804	112117	SCREW, cap, hex head (26B471 only)	8
		SCREW, cap, hex head (26B472 only)	6
805	105328	SCREW, cap, hex head	2
806	108768	SCREW, cap, hex head	4

Ref.	Part	Description	Qty.
807	114380	SCREW, cap, socket head	4
808	---	BRACKET, axial, housing, robot (26B471 only)	1
		BRACKET, axial, housing, robot (26B472 only)	1
809	---	SCREW, cap, hex head (26B472 only)	2
810	113500	SEALANT, anaerobic, blue	1

Dimensions and Mounting



Ref.	Dimension
A	8.4 in. (213 mm)
B	2.75 in. (70 mm)
C	1.75 in. (45 mm)
D	3.18 in. (81 mm)
E	2.88 in. (73 mm)

Heat Assembly

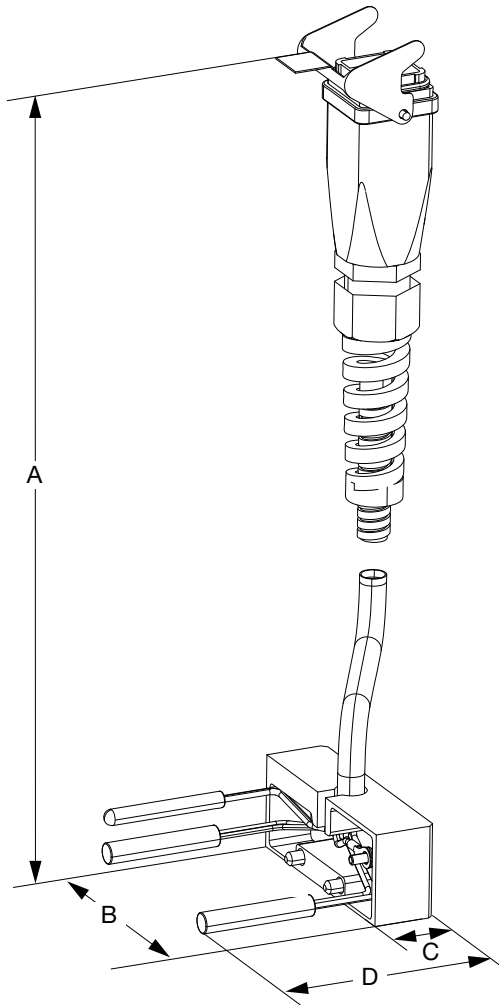

Ref.	Dimension
A	21.75 in. (553 mm)
B	2.8 in. (72 mm)
C	0.75 in. (19 mm)
D	2.1 in. (54 mm)

Wiring Diagrams

Electric Housing Wiring Diagram

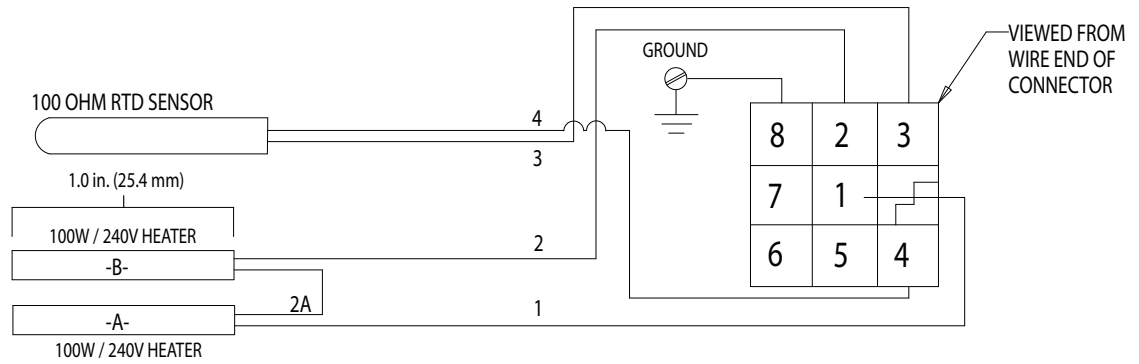

Technical Specifications

Axial Dispense Valve		
	US	Metric
Maximum fluid working pressure	4000 psi	28 MPa, 276 bar
Maximum cylinder air pressure	120 psi	0.83 MPa, 8.3 bar
Maximum fluid operating temperature	158°F	70°C
Fluid section sealing	Isolation chamber with dual seals	
Divorced air cylinder	Double acting, buna-n o-rings	
Torques		
See Axial Valve Torque Chart on page 35 for torque to rotate valve	5-45 ft -lb	6.78 - 61.01 N•m
Valve Mounted Solenoid		
Inlet and exhaust port size	1/8 in. NPT(f)	
Outlet port size	O-ring seal	
Electrical connector style	M8 2-pin male	
Voltage	24 VDC	
Solenoid power	12W	
Sound Data		
Normal operation (dispensing)	< 70 dBA	
Inlet/Outlet Sizes		
Air inlet size	1/8 in. NPT(f)	
Air exhaust port size	1/8 in. NPT(f)	
Fluid inlet size	7/8-14 SAE (#10) and 16 JIC	
Fluid outlet size		
Materials of Construction		
Wetted materials	UHMWPE, 17-4 SST, Carbon Steel, PEEK, Chemical Resistant o-rings, Silicon Nitride, and C2 carbide with cobalt binder.	

Weight			
Ambient, Remote Mount Solenoid	Heated, Remote Mount Solenoid	Ambient, Direct Mount Solenoid	Heated, Direct Mount Solenoid
10.3 lb (4.6 kg)	10.6 lb (4.8 kg)	10.6 lb (4.8 kg)	11.0 lb (4.9 kg)

Electrical Specifications			
Voltage	Wattage	RTD Sensor Resistance (Ohms), Pins 3 & 4	Heater Cartridge Resistance (Ohms), Pins 1 & 2
240 V	2 x 100W	110 Ohms @ 20°C (70°F)	1000-1300 Ohms

Axial Valve Torque Chart

Axial Valve Torque (FT-lbs) VS Material Pressure

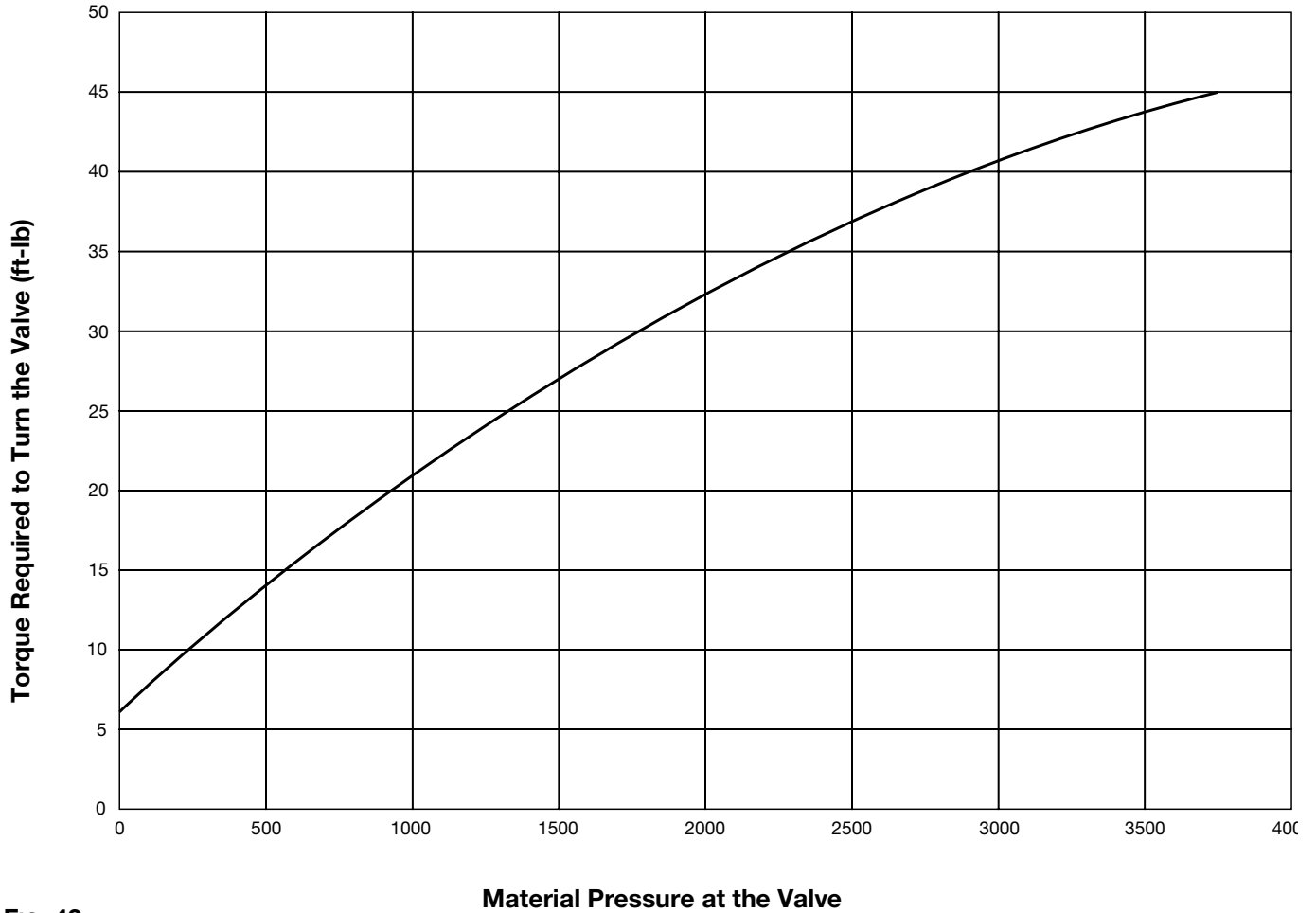

FIG. 42

California Proposition 65

CALIFORNIA RESIDENTS

⚠ WARNING: Cancer and reproductive harm – www.P65warnings.ca.gov.

Graco Standard Warranty

Graco warrants all equipment referenced in this document which is manufactured by Graco and bearing its name to be free from defects in material and workmanship on the date of sale to the original purchaser for use. With the exception of any special, extended, or limited warranty published by Graco, Graco will, for a period of twelve months from the date of sale, repair or replace any part of the equipment determined by Graco to be defective. This warranty applies only when the equipment is installed, operated and maintained in accordance with Graco's written recommendations.

This warranty does not cover, and Graco shall not be liable for general wear and tear, or any malfunction, damage or wear caused by faulty installation, misapplication, abrasion, corrosion, inadequate or improper maintenance, negligence, accident, tampering, or substitution of non-Graco component parts. Nor shall Graco be liable for malfunction, damage or wear caused by the incompatibility of Graco equipment with structures, accessories, equipment or materials not supplied by Graco, or the improper design, manufacture, installation, operation or maintenance of structures, accessories, equipment or materials not supplied by Graco.

This warranty is conditioned upon the prepaid return of the equipment claimed to be defective to an authorized Graco distributor for verification of the claimed defect. If the claimed defect is verified, Graco will repair or replace free of charge any defective parts. The equipment will be returned to the original purchaser transportation prepaid. If inspection of the equipment does not disclose any defect in material or workmanship, repairs will be made at a reasonable charge, which charges may include the costs of parts, labor, and transportation.

THIS WARRANTY IS EXCLUSIVE, AND IS IN LIEU OF ANY OTHER WARRANTIES, EXPRESS OR IMPLIED, INCLUDING BUT NOT LIMITED TO WARRANTY OF MERCHANTABILITY OR WARRANTY OF FITNESS FOR A PARTICULAR PURPOSE.

Graco's sole obligation and buyer's sole remedy for any breach of warranty shall be as set forth above. The buyer agrees that no other remedy (including, but not limited to, incidental or consequential damages for lost profits, lost sales, injury to person or property, or any other incidental or consequential loss) shall be available. Any action for breach of warranty must be brought within two (2) years of the date of sale.

GRACO MAKES NO WARRANTY, AND DISCLAIMS ALL IMPLIED WARRANTIES OF MERCHANTABILITY AND FITNESS FOR A PARTICULAR PURPOSE, IN CONNECTION WITH ACCESSORIES, EQUIPMENT, MATERIALS OR COMPONENTS SOLD BUT NOT MANUFACTURED BY GRACO. These items sold, but not manufactured by Graco (such as electric motors, switches, hose, etc.), are subject to the warranty, if any, of their manufacturer. Graco will provide purchaser with reasonable assistance in making any claim for breach of these warranties.

In no event will Graco be liable for indirect, incidental, special or consequential damages resulting from Graco supplying equipment hereunder, or the furnishing, performance, or use of any products or other goods sold hereto, whether due to a breach of contract, breach of warranty, the negligence of Graco, or otherwise.

FOR GRACO CANADA CUSTOMERS

The Parties acknowledge that they have required that the present document, as well as all documents, notices and legal proceedings entered into, given or instituted pursuant hereto or relating directly or indirectly hereto, be drawn up in English. Les parties reconnaissent avoir convenu que la rédaction du présente document sera en Anglais, ainsi que tous documents, avis et procédures judiciaires exécutés, donnés ou intentés, à la suite de ou en rapport, directement ou indirectement, avec les procédures concernées.

Graco Information

Sealant and Adhesive Dispensing Equipment

For the latest information about Graco products, visit www.graco.com.

For patent information, see www.graco.com/patents.

TO PLACE AN ORDER, contact your Graco distributor, go to www.graco.com, or call to identify the nearest distributor.

If calling from the USA: 1-800-746-1334

If calling from outside the USA: 0-1-330-966-3000

All written and visual data contained in this document reflects the latest product information available at the time of publication. Graco reserves the right to make changes at any time without notice.

Original instructions. This manual contains English. MM 3A8166

Graco Headquarters: Minneapolis

International Offices: Belgium, China, Japan, Korea

GRACO INC. AND SUBSIDIARIES • P.O. BOX 1441 • MINNEAPOLIS MN 55440-1441 • USA
Copyright 2021, Graco Inc. All Graco manufacturing locations are registered to ISO 9001.

www.graco.com
Revision E, May 2024