

# E-Flo<sup>®</sup> DCi 2-Ball Pumps

3A7826B

EN

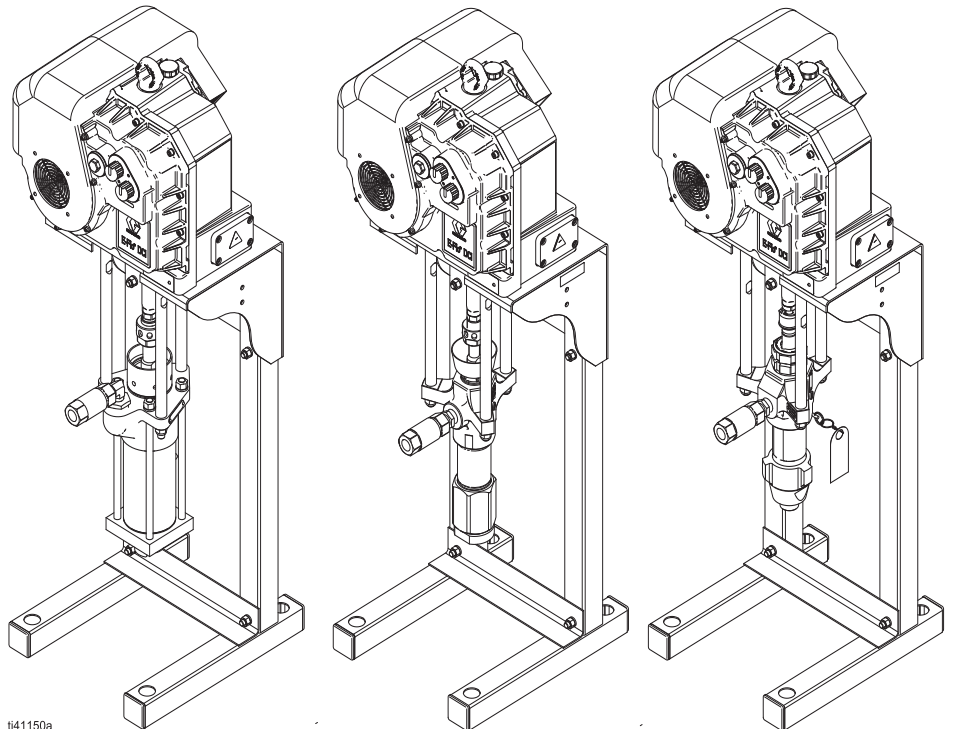
*Electric drive piston pumps for high volume paint circulation applications. For professional use only*

See page 3 for model description  
and page 44 for maximum  
working pressure.



## Important Safety Instructions

Read all warnings and instructions in this manual and in the **Related Manuals** before using the equipment. Save all instructions.



t41150a

# Contents

<b>Related Manuals</b> .....	<b>2</b>	<b>Troubleshooting</b> .....	<b>15</b>
<b>Models</b> .....	<b>3</b>	<b>Repair</b> .....	<b>16</b>
<b>Approvals</b> .....	<b>3</b>	Prepare Equipment for Service .....	16
<b>Warnings</b> .....	<b>4</b>	Disconnect the Pump Lower .....	16
<b>Typical Installation</b> .....	<b>7</b>	Reconnect the Lower and Motor .....	17
<b>Installation</b> .....	<b>8</b>	<b>Pump Matrix</b> .....	<b>18</b>
Hazardous Location Cabling and Conduit		<b>Parts</b> .....	<b>23</b>
Requirements .....	8	Parts List .....	27
Power Requirements .....	8	<b>Dimensions</b> .....	<b>28</b>
Location Requirements .....	8	Y10BK1 .....	28
Mount the Pump .....	8	Y30BE1 .....	29
Required System Accessories .....	9	Y30B11 .....	30
Required Fluid Line Accessories .....	9	Y32BB1 .....	31
Grounding .....	9	<b>Performance Charts</b> .....	<b>32</b>
Connect Supply Wiring .....	10	<b>Mounting Hole Patterns</b> .....	<b>42</b>
Install the Fill Cap .....	11	Mounting Bracket Pattern .....	42
Flush Before Using the Equipment .....	11	Floor Stand Mounting Pattern .....	43
<b>Operation</b> .....	<b>12</b>	<b>Technical Specifications</b> .....	<b>44</b>
Pressure Relief Procedure .....	12	<b>California Proposition 65</b> .....	<b>47</b>
Startup .....	12	<b>Graco Standard Warranty</b> .....	<b>48</b>
Shutdown .....	12		
<b>Maintenance</b> .....	<b>13</b>		
Preventive Maintenance Schedule .....	13		
Flushing Procedure .....	13		
Change the Oil .....	13		
Check Oil Level .....	13		
Add Oil .....	14		

## Related Manuals

Manual No.	Description	Referenced Equipment
3A8352	E-Flo® DCi Motor Installation and Operation Manual	Motor ★
311717	Carbon Steel 1000 cc Lower, Instructions/Parts	Lower ★
311762	Xtreme® Lowers, Repair/Parts Manual	
311825	Dura-Flo® Lowers, Instructions/Parts Manual	
311827	Dura-Flo® Lowers, Repair/Parts Manual	
311619	Pump Mounting Kits Instructions	Pump Mount
3A8471	DCi Link Control Module	Control Module
★ Find your specific motor and lower model in the <b>Pump Matrix</b> on page 18.		




# Models

The part number for your equipment is printed on the equipment identification label. The part number consists for six alphanumeric digits which are based on pump configuration as shown in the following table. The full pump model numbers and associated motor and lower model numbers are listed in the **Pump Matrix** on page 18. For motor and lower repair manuals, see **Related Manuals** on page 2.

First Digit	Second and Third Digit	Fourth Digit	Fifth Digit	Sixth Digit
<b>Intelligent</b>	<b>Horsepower and Lower Size</b>	<b>Motor Controls, Motor Type, and Motor Agency Approvals‡</b>	<b>Lower Type</b>	<b>Mounting Type</b>
<b>Y: Intelligent</b>	<b>31:</b> 2 HP, 145 cc <b>24:</b> 2 HP, 180 cc <b>21:</b> 2 HP, 220 cc <b>16:</b> 2 HP, 290 cc <b>46:</b> 3 HP, 145 cc <b>40:</b> 3 HP, 180 cc <b>30:</b> 3 HP, 220 cc <b>25:</b> 3 HP, 290 cc <b>15:</b> 3 HP, 430 cc <b>12:</b> 3 HP, 580 cc <b>06:</b> 3 HP, 1000 cc <b>70:</b> 5 HP, 180 cc <b>60:</b> 5 HP, 220 cc <b>57:</b> 5 HP, 220 cc <b>45:</b> 5 HP, 290 cc <b>32:</b> 5 HP, 430 cc <b>23:</b> 5 HP, 580 cc <b>10:</b> 5 HP, 1000 cc	<b>B:</b> Basic, three phase ATEX, IECEx, SGS, UKEx  <b>D:</b> Basic, three phase ATEX, IECEx, JPEX, KCs Ex, CCC-Ex	<b>A:</b> 3 UHMW/2 PTFE, Stainless <b>B:</b> 3 UHMW/2 Tuffstack, Stainless <b>D:</b> 3 PTFE/2 Leather, Carbon Steel <b>E:</b> 4 Leather/1 PTFE, Stainless <b>G:</b> PTFE /PTFE, Stainless <b>H:</b> PTFE/Leather, Stainless <b>K:</b> UHMW/Leather, Carbon Steel <b>L:</b> 3 UHMWPE/2 Leather, SST <b>M:</b> 4 Leather/3 UHMWPE, Stainless <b>S:</b> 2 PTFE/3 UHMWPE, Stainless <b>1:</b> 3 Xtreme/2 Leather, Carbon Steel	<b>0:</b> No Stand <b>1:</b> Stand <b>2:</b> Wall Bracket









‡ Motor approvals are listed in the E-Flo DCi motor manual. See **Related Manuals**, page 2.

# Approvals





Pump Model	Pump Approvals
YBxxxx YDxxxx	   II 2 G Ex db h IIB T3 Gb 0°C ≤ Ta ≤ 40°C

# Warnings

The following warnings are for the setup, use, grounding, maintenance, and repair of this equipment. The exclamation point symbol alerts you to a general warning and the hazard symbols refer to procedure-specific risks. When these symbols appear in the body of this manual or on warning labels, refer back to these Warnings. Product-specific hazard symbols and warnings not covered in this section may appear throughout the body of this manual where applicable.

 <h1 style="margin: 0;">DANGER</h1>	
 	<p><b>SEVERE ELECTRIC SHOCK HAZARD</b></p> <p>This equipment is powered by more than 240V. Contact with this voltage will cause death or serious injury.</p> <ul style="list-style-type: none"> <li>• Turn off and disconnect the power at the main switch before disconnecting any cables and before servicing equipment.</li> <li>• This equipment must be grounded. Connect only to a grounded power source.</li> <li>• All electrical wiring must be done by a qualified electrician and comply with all local codes and regulations.</li> </ul>
 <h1 style="margin: 0;">WARNING</h1>	
   	<p><b>FIRE AND EXPLOSION HAZARD</b></p> <p>Flammable fumes, such as solvent and paint fumes, in <b>work area</b> can ignite or explode. Paint or solvent flowing through the equipment can cause static sparking. To help prevent fire and explosion:</p> <ul style="list-style-type: none"> <li>• Use equipment only in well-ventilated area.</li> <li>• Eliminate all ignition sources; such as pilot lights, cigarettes, portable electric lamps, and plastic drop cloths (potential static sparking).</li> <li>• Ground all equipment in the work area. See <b>Grounding</b> instructions.</li> <li>• Keep work area free of debris, including solvent, rags, and gasoline.</li> <li>• Do not plug or unplug power cords, or turn power or light switches on or off when flammable fumes are present.</li> <li>• Use only grounded hoses.</li> <li>• Hold gun firmly to side of grounded pail when triggering into pail. Do not use pail liners unless they are anti-static or conductive.</li> <li>• <b>Stop operation immediately</b> if static sparking occurs or you feel a shock. Do not use equipment until you identify and correct the problem.</li> <li>• Keep a working fire extinguisher in the work area.</li> </ul>

# ! WARNING

	<p><b>PRESSURIZED EQUIPMENT HAZARD</b></p> <p>Fluid from the equipment, leaks, or ruptured components can splash in the eyes or on skin and cause serious injury.</p> <ul style="list-style-type: none"> <li>• Follow the <b>Pressure Relief Procedure</b> when you stop spraying/dispensing and before cleaning, checking, or servicing equipment.</li> <li>• Tighten all fluid connections before operating the equipment.</li> <li>• Check hoses, tubes, and couplings daily. Replace worn or damaged parts immediately.</li> </ul>
	<p><b>EQUIPMENT MISUSE HAZARD</b></p> <p>Misuse can cause death or serious injury.</p> <ul style="list-style-type: none"> <li>• Do not operate the unit when fatigued or under the influence of drugs or alcohol.</li> <li>• Do not exceed the maximum working pressure or temperature rating of the lowest rated system component. See <b>Technical Specifications</b> in all equipment manuals.</li> <li>• Use fluids and solvents that are compatible with equipment wetted parts. See <b>Technical Specifications</b> in all equipment manuals. Read fluid and solvent manufacturer's warnings. For complete information about your material, request Safety Data Sheets (SDSs) from distributor or retailer.</li> <li>• Do not leave the work area while equipment is energized or under pressure.</li> <li>• Turn off all equipment and follow the <b>Pressure Relief Procedure</b> when equipment is not in use.</li> <li>• Check equipment daily. Repair or replace worn or damaged parts immediately with genuine manufacturer's replacement parts only.</li> <li>• Do not alter or modify equipment. Alterations or modifications may void agency approvals and create safety hazards.</li> <li>• Make sure all equipment is rated and approved for the environment in which you are using it.</li> <li>• Use equipment only for its intended purpose. Call your distributor for information.</li> <li>• Route hoses and cables away from traffic areas, sharp edges, moving parts, and hot surfaces.</li> <li>• Do not kink or over bend hoses or use hoses to pull equipment.</li> <li>• Keep children and animals away from work area.</li> <li>• Comply with all applicable safety regulations.</li> </ul>
	<p><b>MOVING PARTS HAZARD</b></p> <p>Moving parts can pinch, cut, or amputate fingers and other body parts.</p> <ul style="list-style-type: none"> <li>• Keep clear of moving parts.</li> <li>• Do not operate equipment with protective guards or covers removed.</li> <li>• Pressurized equipment can start without warning. Before checking, moving, or servicing equipment, follow the <b>Pressure Relief Procedure</b> and disconnect all power sources.</li> </ul>
	<p><b>TOXIC FLUID OR FUMES HAZARD</b></p> <p>Toxic fluids or fumes can cause serious injury or death if splashed in the eyes or on skin, inhaled, or swallowed.</p> <ul style="list-style-type: none"> <li>• Read Safety Data Sheets (SDSs) to know the specific hazards of the fluids you are using.</li> <li>• Store hazardous fluid in approved containers, and dispose of it according to applicable guidelines.</li> </ul>

# **WARNING**



## **BURN HAZARD**

Equipment surfaces and fluid that is heated can become very hot during operation. To avoid severe burns:

- Do not touch hot fluid or equipment.



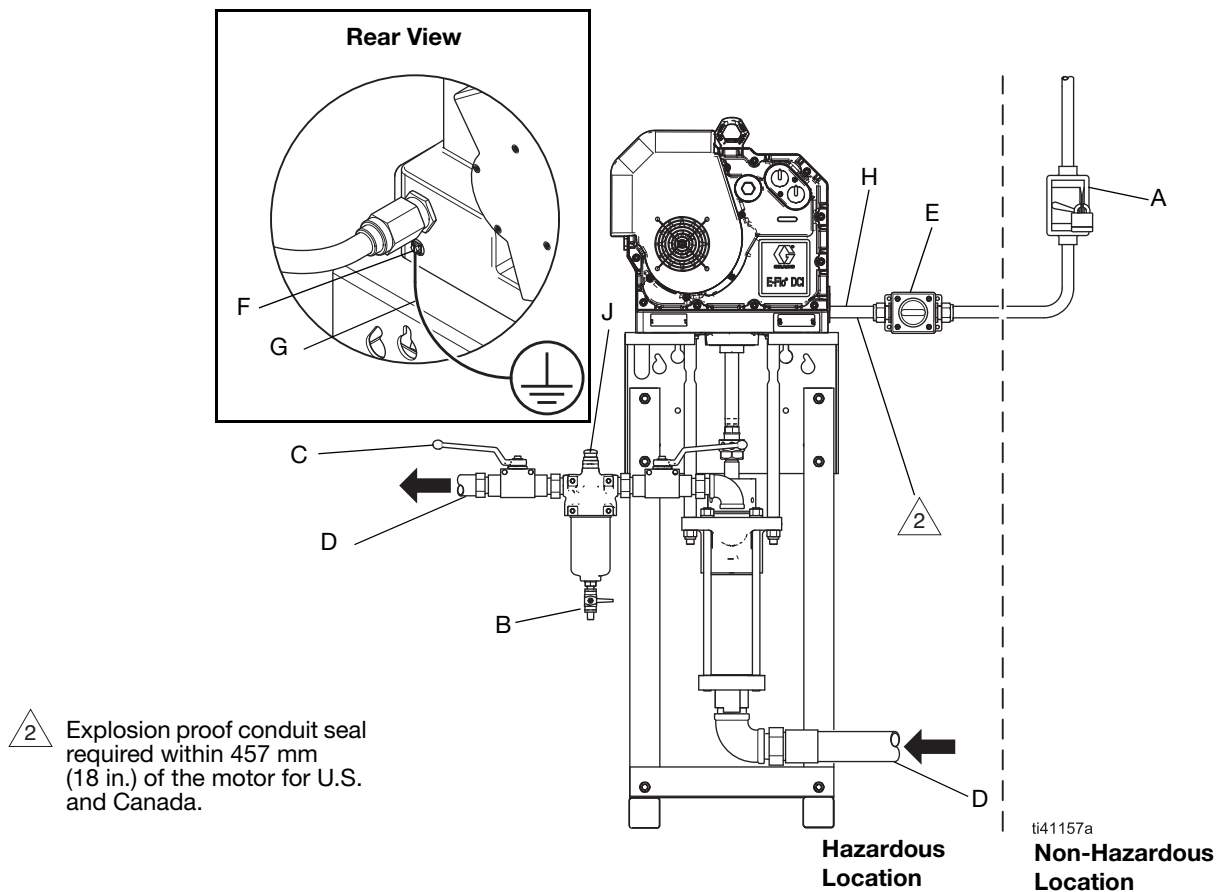
## **PERSONAL PROTECTIVE EQUIPMENT**

Wear appropriate protective equipment when in the work area to help prevent serious injury, including eye injury, hearing loss, inhalation of toxic fumes, and burns. Protective equipment includes but is not limited to:

- Protective eyewear, and hearing protection.
- Respirators, protective clothing, and gloves as recommended by the fluid and solvent manufacturer.

# Typical Installation

The system accessories shown in FIG. 1 are not included. Contact your Graco distributor to design a complete system.

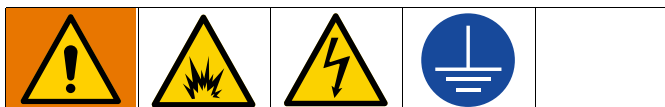


**FIG. 1 Typical Installation**

**Key:**

- A Electrical disconnect
- B Fluid drain valve
- C Fluid shutoff valve
- D Fluid line
- E Start/stop switch
- F Ground wire connection
- G Static ground wire
- H Explosion proof conduit seal
- J Fluid filter

# Installation



Installation of this equipment involves potentially hazardous procedures. Only trained and qualified personnel who have read and who understand the information in this manual should install this equipment. All electrical wiring must be done by a qualified electrician and comply with all local codes and regulations.

## Hazardous Location Cabling and Conduit Requirements

### Explosion Proof Requirements

All electrical wiring in the hazardous locations must be encased in approved explosion-proof conduit that is suitable for Class I, Division I, Group C and D locations. Follow all national, state, and local electrical codes and regulations.

#### US and Canada Conduit Location Requirement:

Install a conduit seal within 457 mm (18 in.) of the motor enclosure.

**Cable Rating Requirement:** Use cables with a minimum rating of 70°C (158°F).



### Flame Proof Requirements

Use appropriate conduit, connectors, and cable glands rated for Ex II 2 G. Follow all national, state, and local electrical codes and regulations.

**Cable Rating Requirement:** Use cables with a minimum rating of 70°C (158°F).

## Power Requirements

The system requires a dedicated circuit protected with a circuit breaker in each ungrounded phase.

Model by Horsepower	Voltage	Phase	Hz	kVA
2 HP (1.49 kW)	380–480 Vac	3	50/60	2.7
3 HP (2.24 kW)	380–480 Vac	3	50/60	3.4
5 HP (3.73 kW)	380–480 Vac	3	50/60	5.7

## Location Requirements

- There must be sufficient space on all sides of the equipment for installation, operator access, maintenance, and air circulation.
- The mounting surface and mounting hardware must be strong enough to support the weight of the equipment, fluid, hoses, and stress caused during operation.
- There must be an electrical disconnect (A) within easy reach of the equipment. See **FIG. 1 Typical Installation**, page 7.

## Mount the Pump

Follow the instructions in the pump mounting kit manual to mount the pump on a stand or on the wall. See **Related Manuals**, page 2.

### Stand Mount

1. Use the **Floor Stand Mounting Pattern**, page 43.
2. Bolt the stand to the floor with M19 (5/8 in.) bolts. Use bolts that engage at least 152 mm (6 in.) into the concrete floor to prevent the pump from tipping.
3. Use shims to level the pump if needed.



## Wall Mount

1. Use the wall mount bracket as a template.

**NOTE:** The bracket has two mounting hole groups. See **Mounting Bracket Pattern**, page 42.

2. Drill four 7/16 in. (11 mm) holes into the wall. Bolt the bracket securely to the wall. Always use bolts and washers designed to hold in the wall's construction.
3. Attach the pump assembly to the mounting bracket.

## Required System Accessories

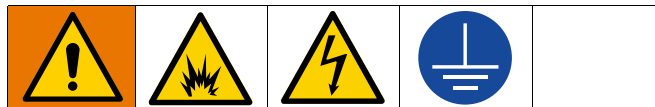
- **Electrical disconnect (A):** Required in the system to disconnect and isolate electricity from the motor.
- **Start stop switch (E):** Temporarily runs or stops the motor. Must be approved for hazardous locations.

## Required Fluid Line Accessories

Install accessories as shown in FIG. 1, using adapters as necessary. Make sure they meet the system's size and pressure rating requirements. See **Technical Specifications**, page 44.

- **Fluid drain valve (B):** Required in the system to relieve pressure in the hose and circulation system.
- **Fluid shutoff valve (C):** shuts off fluid flow.

## Grounding

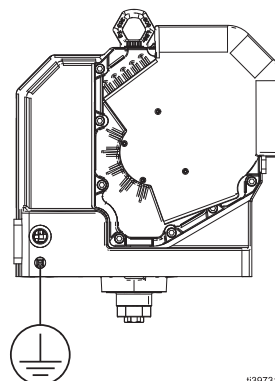


The equipment must be grounded to reduce the risk of static sparking and electric shock. Electric or static sparking can cause fumes to ignite or explode. Improper grounding can cause electric shock. Grounding provides an escape wire for the electric current.

### Static Grounding

Use a ground wire (G) to connect the motor to a true earth ground.

1. Loosen the ground screw.
2. Insert a ground wire (G).

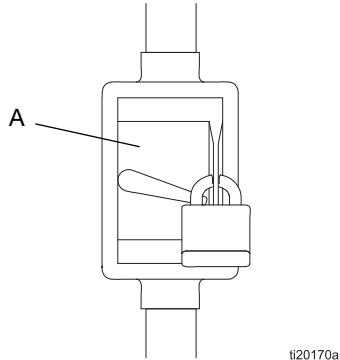


**FIG. 2 Motor ground wire location**

3. Tighten the ground screw securely.
4. Connect the other end of the ground wire (G) to a true earth ground.

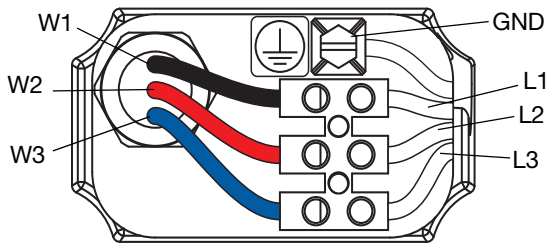
## Electrical Grounding

1. Ensure that the electrical disconnect (A) is shut off and locked out.



**Fig. 3 Locked out disconnect example**

2. Remove the cover to access the motor electrical wiring compartment (EC).
3. Connect the supply ground wire to GND.



ti40756a

**Fig. 4 Motor wiring**

4. Connect the other end of the supply ground wire to a true earth ground.

## Component Grounding

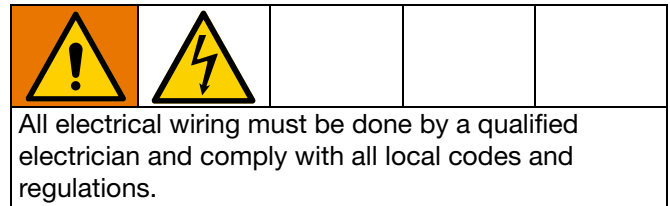
**Fluid hoses:** Use only electrically conductive hoses with a maximum of 500 ft. (150 m) combined hose length to ensure grounding continuity. Check the electrical resistance of hoses. If total resistance to ground exceeds 25 megohms, replace hose immediately.

**Fluid supply container:** Follow your local code.

**Solvent pails used when flushing:** Follow local code. Use only conductive metal pails, placed on a grounded surface. Do not place the pail on a non-conductive surface, such as paper or cardboard, which interrupts grounding continuity.

**To maintain grounding continuity when flushing or relieving pressure:** Hold metal part of the spray gun or valve firmly to the side of a grounded metal pail, then trigger the gun or open the valve.

## Connect Supply Wiring



1. Ensure that the electrical disconnect (A) is shut off and locked out. See FIG. 3.
2. Bring the power wires (L1, L2, and L3) through the 3/4-14npt(f) inlet port of the electrical wiring compartment. Connect the wires to the terminal blocks.

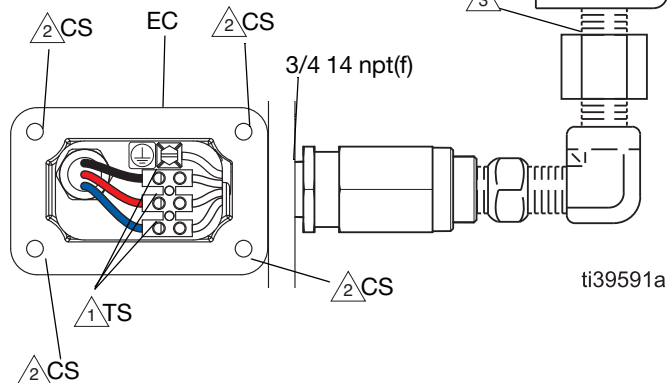
**NOTE:** When using a communication module, the wire orientation is important. L1 and L3 transmit communication. Incorrectly wiring the communication module will result in communication failure. See FIG. 4.

- L1 to W1 (black)
  - L2 to W2 (red)
  - L3 to W3 (blue)
3. Torque terminal screws (TS) to 7 in-lb (0.79 N•m). **Do not over-torque.**
  4. Close the electrical wiring compartment (EC). Torque the cover screws (CS) to 15 ft-lb (20 N•m).

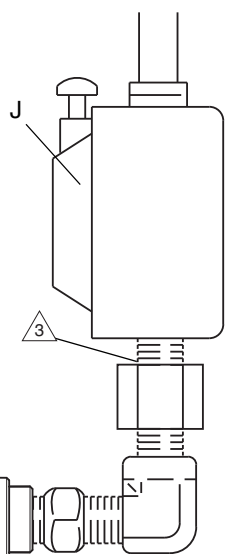
1 Torque to 7 in-lb (0.79 N•m)

2 Torque to 15 ft-lb (20 N•m)

3 A conduit seal is required within 457 mm (18 in.) of the motor for US and Canadian installations.

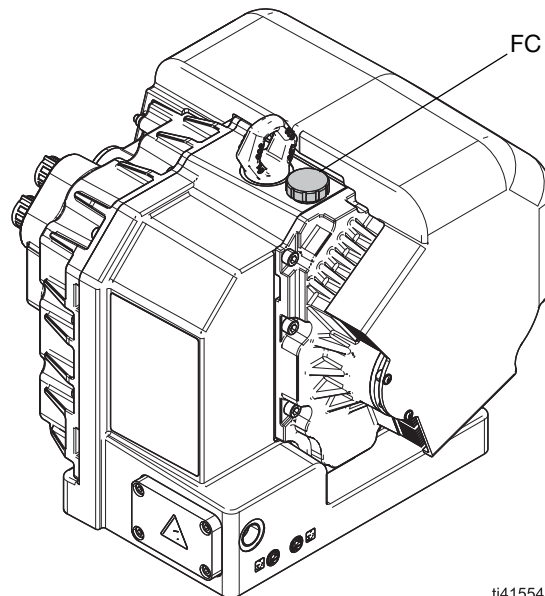


**FIG. 5 Motor electrical compartment wires**



## Install the Fill Cap

The motor is pre-filled with oil. Replace the shipping plug with the fill cap (FC) before first use.




**FIG. 6 Fill cap**

## Flush Before Using the Equipment

The pump fluid section was tested with lightweight oil, which is left in the fluid passages to protect parts. To avoid contaminating your fluid with oil, flush the equipment with a compatible solvent before using the equipment.

# Operation

## Pressure Relief Procedure

 Follow the Pressure Relief Procedure whenever you see this symbol.



This equipment stays pressurized until pressure is manually relieved. To help prevent serious injury from pressurized fluid, such as splashing fluid and moving parts, follow the **Pressure Relief Procedure** when you stop dispensing and before cleaning, checking, or servicing the equipment.

1. Shut off the start/stop switch (E).
2. Shut off and lock out the electrical disconnect (A).
3. Open the fluid drain valve (B), having a waste container ready to catch drainage. Leave open until you are ready to pressurize the system again.

## Startup

1. Follow the motor start up instructions in the motor operation manual. See **Related Manuals**, page 2
2. Run the pump at a slow speed until the pump primes the fluid lines and forces air out of the system.

## Shutdown

1. Follow the **Pressure Relief Procedure**, page 12.
2. Follow the shutdown instructions in the motor manual. See **Related Manuals**, page 2

# Maintenance

## Preventive Maintenance Schedule

The operating conditions of your particular system determine how often maintenance is required.

Establish a preventive maintenance schedule by recording when and what kind of maintenance is needed, and then determine a regular schedule for checking your system.

## Flushing Procedure



To avoid fire and explosion, always ground equipment and waste container. To avoid static sparking and injury from splashing, always flush at the lowest possible pressure.

- Flush before changing fluids, before fluid can dry in the equipment, before storing, and before repairing equipment.
  - Flush at the lowest pressure possible. Check connectors for leaks and tighten as necessary.
  - Flush with a fluid that is compatible with the fluid being dispensed and the equipment wetted parts
1. Follow the **Pressure Relief Procedure** on page 12.
  2. Supply a compatible flushing material to the system.
  3. Set pump to lowest possible fluid pressure, and start the pump.
  4. Flush long enough to thoroughly clean the system.
  5. Follow the **Pressure Relief Procedure** on page 12.

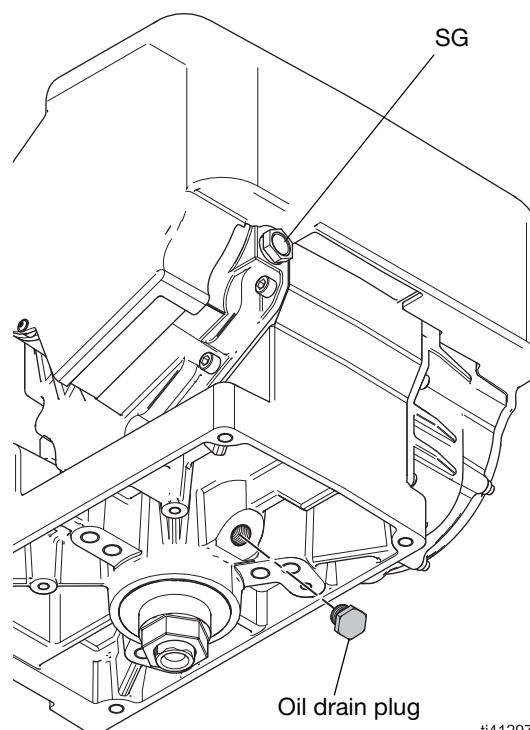
## Change the Oil

Change the oil after a break-in period of 200,000–300,000 cycles. After the break-in period, change the oil once a year.

1. Place a minimum 2 quart (1.9 liter) container under the oil drain port.
2. Remove the oil drain plug.
3. Allow all oil to drain from the motor.
4. Reinstall the oil drain plug. Torque to 25–30 ft-lb (34–40 N•m).
5. **Add Oil**, page 14.

## Check Oil Level

Check the oil level in the sight glass (SG). The oil level should be near the halfway point of the sight glass when the unit is not running.



**FIG. 7 Oil drain plug and sight glass**

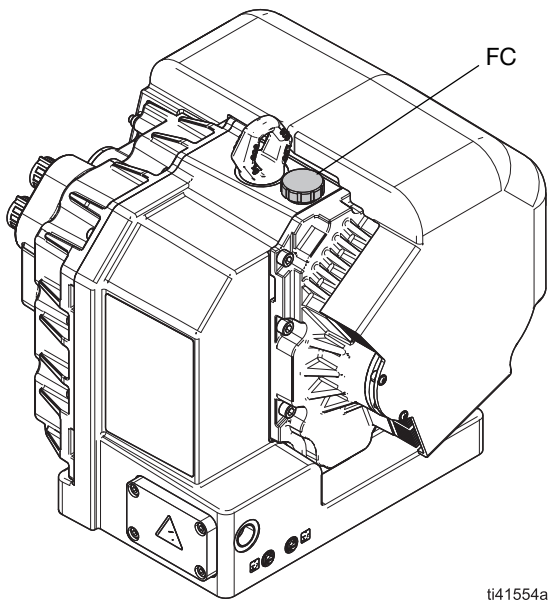
ti41297a

## Add Oil

1. Open the fill cap (FC).
2. Add a compatible oil. See **Technical Specifications** on page 44.

**NOTE:** The oil capacity is 2.0 quarts (1.9 liters). Do not overfill.

3. Reinstall the fill cap (FC).

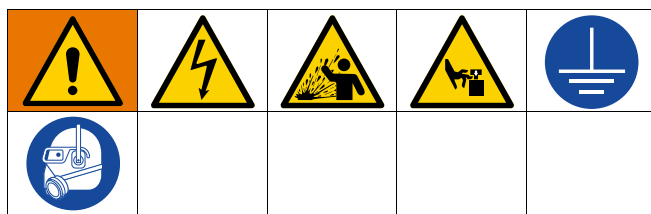


ti41554a

**Fig. 8 Fill cap location**

---

# Troubleshooting

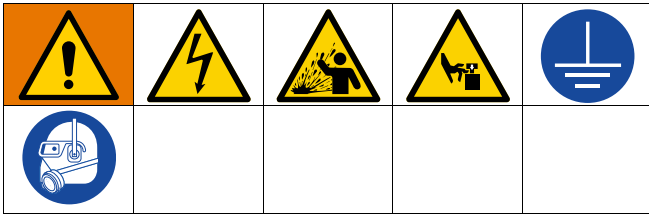


1. Follow the **Pressure Relief Procedure** on page 12, before checking or repairing the equipment.
2. Check all possible remedies before disassembling the pump.

**NOTE:** The LED on the motor will blink if an error is detected. Refer to the motor manual for Error Code Troubleshooting.

Problem	Cause	Solution
Pump output low on both strokes.	Inadequate supply voltage	Verify supply voltage. See <b>Technical Specifications</b> , page 44.
	Exhausted or inadequate fluid supply	Refill the pump fluid supply.
	Clogged fluid components	Clear clogged components.
	Worn piston seal	Replace piston seal. ✓
Pump output low on only one stroke.	Held open or worn ball check valves	Check and repair ball check valves. ✓
	Worn piston packing	Replace packings. ✓
No output.	Improperly installed ball check valves	Check and repair the ball check valves. ✓
Pump operates erratically.	Exhausted or inadequate fluid supply	Refill the pump fluid supply.
	Held open or worn ball check valves	Check and repair the ball check valves. ✓
	Worn piston seal	Replace piston seal. ✓
Pump will not operate.	Inadequate supply voltage	Verify supply voltage. See <b>Technical Specifications</b> , page 44.
	Clogged fluid components	Clear the clogged components.
	Fluid dried on piston rod	Disassemble and clean pump. ✓ <b>NOTE:</b> Stop pump at bottom of stroke to avoid piston rod damage.
✓ See your lower repair manual that corresponds with your model. Repair manuals vary by model. Find your specific lower model in the <b>Pump Matrix</b> on page 18.		

# Repair



**NOTE:** There are no user-serviceable parts in the motor. Contact your Graco representative for assistance.

## Prepare Equipment for Service

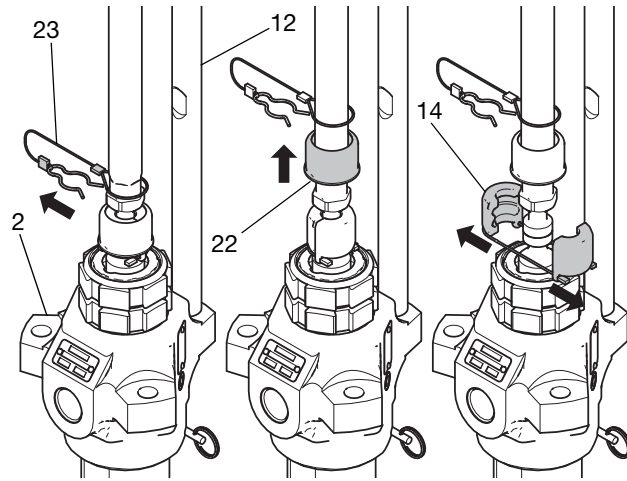
1. Stop the pump at the bottom of its stroke.
2. Shut off and lock out the electrical disconnect (A).
3. Follow the **Pressure Relief Procedure**, page 12.
4. Follow the **Flushing Procedure**, page 13.
5. Disconnect the hoses from the lower and plug the ends to prevent fluid contamination.

## Disconnect the Pump Lower

Disconnect the lower from the motor. Use a repair manual that corresponds with your pump model. Identify pump models with carbon or stainless steel lowers in **Models** on page 3. Find your specific lower model in the **Pump Matrix** on page 18.

### Carbon Steel Lowers

1. Remove the hairpin clip (23) and slide the coupling cover (22) up to remove the coupling assembly (14).

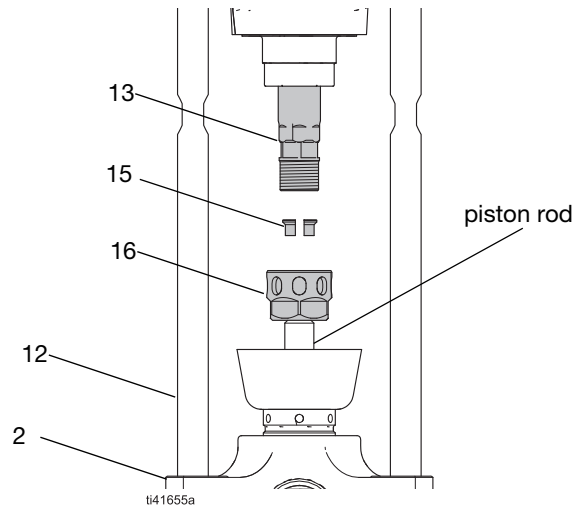


ti23278a  
**FIG. 9 Loosen the coupler**

2. Unscrew the locknuts (20) from the tie rods (12).
3. Separate the lower (2) from the tie rods (12).

### Stainless Steel Lowers

1. Loosen the coupling nut (16) from the coupling adapter (13), and remove the coupling collar (15).



ti41655a  
**FIG. 10 Loosen the coupler**

2. Remove the coupling nut (16) from the piston rod.
3. Unscrew the locknuts (20) from the tie rods (12).
4. Separate the lower (2) from the tie rods (12).



## Reconnect the Lower and Motor

If the coupling adapter (13) and tie rods (12) have not been disassembled from the motor (1), skip to **Carbon Steel Lowers**, page 17, or **Stainless Steel Lowers**, page 17.

If the coupling adapter (13) and tie rods (12) have been disassembled from the motor (1), follow these steps:

1. Screw the tie rods (12) into the motor (1) and torque to 50-60 ft-lb (68-81 N•m).
2. Apply red thread locker to the coupling adapter (13).
3. Screw the coupling adapter (13) into the motor shaft and torque to 90–100 ft-lb (122–135 N•m).
4. Continue to **Carbon Steel Lowers**, page 17, or **Stainless Steel Lowers**, page 17.

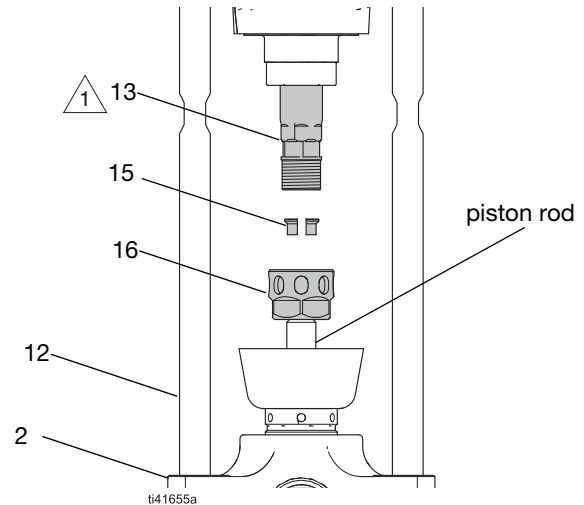
### Carbon Steel Lowers

1. Orient the lower (2) to the motor (1). Position the lower on the tie rods (12).
2. If you are reusing lock nuts (20) and the nylon of the lock nut is worn or cut, add blue thread locker to the tie rod threads.
3. Screw the lock nuts (20) onto the tie rods (12). Tighten the lock nuts (20) and torque to 50–60 ft-lb (68–81 N•m).
4. Raise the motor shaft. Place the coupling cover (22) on the coupling adapter (13) and lower the motor shaft. Place the coupling assembly (14) onto the lower (2) and slide the coupling cover (22) over the coupling assembly (14). Insert the hairpin clip (23).
5. Tighten the lock nuts (6) and torque to 50-60 ft-lb (68-81 N•m).
6. Continue to **Test Pump Operation**, page 17.

### Stainless Steel Lowers

1. Assemble the coupling nut (13) over the piston rod.
2. Orient the lower (2) to the motor (1). Position the lower on the tie rods (4).
3. If you are reusing lock nuts (20) and the nylon of the lock nut is worn or cut, add blue thread locker to the tie rod threads.

4. Screw the lock nuts (20) onto the tie rods (12). Leave the lock nuts (20) loose enough to allow the lower to move so that it can be aligned correctly.



- 1 Apply red thread locker.

**FIG. 11 Attach the coupler**

5. Insert the coupling collars (15) into the coupling nut (16). Tighten the coupling nut (16) onto the coupling adapter (13) and torque to 90–100 ft-lb (122–135 N•m) to align the motor shaft with the piston rod.
6. Tighten the lock nuts (6) and torque to 50-60 ft-lb (68-81 N•m).
7. Continue to **Test Pump Operation**, page 17.

### Test Pump Operation

1. Test the pump operation before reinstalling it in the system.
  - a. Connect hoses and flush the pump. See **Flushing Procedure**, page 13.
  - b. Check for smooth operation and leaks while flushing.
  - c. Adjust or repair as necessary before reinstalling in the system.
2. Reconnect the pump ground wire before operating.

# Pump Matrix

## Y31xxx

Pumps with 2 HP motors and 145 cc Lovers

Pump Model	Motor	Lower
Y31B10	YM1022	L145C1
Y31D10	YM1024	L145C1
Y31BH0	YM1022	236458
Y31DH0	YM1024	236458
Y31BS0	YM1022	L145C1
Y31DS0	YM1024	L145C1
Y31B11	YM1022	L145C1
Y31D11	YM1024	L145C1
Y31BH1	YM1022	236458
Y31DH1	YM1024	236458
Y31BS1	YM1022	L145C1
Y31DS1	YM1024	L145C1
Y31B12	YM1022	L145C1
Y31D12	YM1024	L145C1
Y31BH2	YM1022	236458
Y31DH2	YM1024	236458
Y31BS2	YM1022	L145C1
Y31DS2	YM1024	L145C1

## Y46xxx

Pumps with 3 HP motor and 145 cc lower displacement

Pump Model	Motor	Lower
Y46BH0	YM1032	236458
Y46DH0	YM1034	236458
Y46BS0	YM1032	L145SS
Y46DS0	YM1034	L145SS
Y46BH1	YM1032	236458
Y46DH1	YM1034	236458
Y46BS1	YM1032	L145SS
Y46DS1	YM1034	L145SS
Y46BH2	YM1032	236458
Y46DH2	YM1034	236458
Y46BS2	YM1032	L145SS
Y46DS2	YM1034	L145SS

## Y24xxx

Pumps with 2 HP motor and 180 cc lower displacement

Pump Model	Motor	Lower
Y24B10	YM1022	L180C1
Y24D10	YM1024	L180C1
Y24BE0	YM1022	236456
Y24DE0	YM1024	236456
Y24B11	YM1022	L180C1
Y24D11	YM1024	L180C1
Y24BE1	YM1022	236456
Y24DE1	YM1024	236456
Y24B12	YM1022	L180C1
Y24D12	YM1024	L180C1
Y24BE2	YM1022	236456
Y24DE2	YM1024	236456

## Y40xxx

Pumps with 3 HP motors and 180 cc Lovers

Pump Model	Motor	Lower
Y40BE0	YM1032	236456
Y40DE0	YM1034	236456
Y40BE1	YM1032	236456
Y40DE1	YM1034	236456
Y40BE2	YM1032	236456
Y40DE2	YM1034	236456

## Y70xxx

Pumps with 5 HP motor and 180 cc lower displacement

Pump Model	Motor	Lower
Y70B10	YM1052	L180C1
Y70D10	YM1054	L180C1
Y70B11	YM1052	L180C1
Y70D11	YM1054	L180C1
Y70B12	YM1052	L180C1
Y70D12	YM1054	L180C1

## Y21xxx

Pumps with 2 HP motor and 220 cc lower displacement

Pump Model	Motor	Lower
Y21B10	YM1022	L220C1
Y21D10	YM1024	L220C1
Y21BE0	YM1022	236470
Y21DE0	YM1024	236470
Y21B11	YM1022	L220C1
Y21D11	YM1024	L220C1
Y21BE1	YM1022	236470
Y21DE1	YM1024	236470
Y21B12	YM1022	L220C1
Y21D12	YM1024	L220C1
Y21BE2	YM1022	236470
Y21DE2	YM1024	236470

## Y30xxx

Pumps with 3 HP motors and 220 cc lower displacement

Pump Model	Motor	Lower
Y30B10	YM1032	L220C1
Y30D10	YM1034	L220C1
Y30BE0	YM1032	236470
Y30DE0	YM1034	236470
Y30BS0	YM1032	L220SS
Y30DS0	YM1034	L220SS
Y30B11	YM1032	L220C1
Y30D11	YM1034	L220C1
Y30BE1	YM1032	236470
Y30DE1	YM1034	236470
Y30BS1	YM1032	L220SS
Y30DS1	YM1034	L220SS
Y30B12	YM1032	L220C1
Y30D12	YM1034	L220C1
Y30BE2	YM1032	236470
Y30DE2	YM1034	236470
Y30BS2	YM1032	L220SS
Y30DS2	YM1034	L220SS

## Y57xxx

Pumps with 5 HP motor and 220 cc lower displacement

Pump Model	Motor	Lower
Y57BS0	YM1052	L220SS
Y57DS0	YM1054	L220SS
Y57BS1	YM1052	L220SS
Y57DS1	YM1054	L220SS
Y57BS2	YM1052	L220SS
Y57DS2	YM1054	L220SS

## Y60xxx

Pumps with 5 HP motor and 220 cc lower displacement

Pump Model	Motor	Lower
Y60B10	YM1052	L220C1
Y60D10	YM1054	L220C1
Y60B11	YM1052	L220C1
Y60D11	YM1054	L220C1
Y60B12	YM1052	L220C1
Y60D12	YM1054	L220C1

## Y16xxx

Pumps with 2 HP motor and 290 cc lower displacement

Pump Model	Motor	Lower
Y16B10	YM1022	L290C1
Y16D10	YM1024	L290C1
Y16BE0	YM1022	237514
Y16DE0	YM1024	237514
Y16B11	YM1022	L290C1
Y16D11	YM1024	L290C1
Y16BE1	YM1022	237514
Y16DE1	YM1024	237514
Y16B12	YM1022	L290C1
Y16D12	YM1024	L290C1
Y16BE2	YM1022	237514
Y16DE2	YM1024	237514

## Y25xxx

Pumps with 3 HP motor and 290 cc lower displacement

Pump Model	Motor	Lower
Y25B10	YM1032	L290C1
Y25D10	YM1034	L290C1
Y25BE0	YM1032	237514
Y25DE0	YM1034	237514
Y25B11	YM1032	L290C1
Y25D11	YM1034	L290C1
Y25BE1	YM1032	237514
Y25DE1	YM1034	237514
Y25B12	YM1032	L290C1
Y25D12	YM1034	L290C1
Y25BE2	YM1032	237514
Y25DE2	YM1034	237514

## Y45xxx

Pumps with 5 HP motor and 290 cc lower displacement

Pump Model	Motor	Lower
Y45BE0	YM1052	237514
Y45DE0	YM1054	237514
Y45BS0	YM1052	L290SS
Y45DS0	YM1054	L290SS
Y45BE1	YM1052	237514
Y45DE1	YM1054	237514
Y45BS1	YM1052	L290SS
Y45DS1	YM1054	L290SS
Y45BE2	YM1052	237514
Y45DE2	YM1054	237514
Y45BS2	YM1052	L290SS
Y45DS2	YM1054	L290SS

## Y32xxx

Pumps with 5 HP motors and 430 cc Lower

Pump Model	Motor	Lower
Y32BD0	YM1052	20B119
Y32DD0	YM1054	20B119
Y32BB0	YM1052	687055
Y32DB0	YM1054	687055
Y32BL0	YM1052	20B139
Y32DL0	YM1054	20B139
Y32BM0	YM1052	20B123
Y32DM0	YM1054	20B123
Y32BD1	YM1052	20B119
Y32DD1	YM1054	20B119
Y32BB1	YM1052	687055
Y32DB1	YM1054	687055
Y32BL1	YM1052	20B139
Y32DL1	YM1054	20B139
Y32BM1	YM1052	20B123
Y32DM1	YM1054	20B123
Y32BD2	YM1052	20B119
Y32DD2	YM1054	20B119
Y32BB2	YM1052	687055
Y32DB2	YM1054	687055
Y32BL2	YM1052	20B139
Y32DL2	YM1054	20B139
Y32BM2	YM1052	20B123
Y32DM2	YM1054	20B123

**Y15xxx**

Pumps with 3 HP motor and 430 cc lower displacement

Pump Model	Motor	Lower
Y15BD0	YM1032	20B119
Y15DD0	YM1034	20B119
Y15BE0	YM1032	20B119
Y15DE0	YM1034	20B119
Y15BM0	YM1032	20B123
Y15DM0	YM1034	20B123
Y15BD1	YM1032	20B119
Y15DD1	YM1034	20B119
Y15BB1	YM1032	687055
Y15DB1	YM1034	687055
Y15BM1	YM1032	20B123
Y15DM1	YM1034	20B123
Y15BD2	YM1032	20B119
Y15DD2	YM1034	20B119
Y15BB2	YM1032	687055
Y15DB2	YM1034	687055
Y15BM2	YM1032	20B123
Y15DM2	YM1034	20B123

**Y12xxx**

Pumps with 3HP motor and 580 cc lower displacement

Pump Model	Motor	Lower
Y12BD0	YM1032	20B120
Y12DD0	YM1034	20B120
Y12BA0	YM1032	20B121
Y12DA0	YM1034	20B121
Y12BM0	YM1032	20B125
Y12DM0	YM1034	20B125
Y12BD1	YM1032	20B120
Y12DD1	YM1034	20B120
Y12BA1	YM1032	20B121
Y12DA1	YM1034	20B121
Y12BM1	YM1032	20B125
Y12DM1	YM1034	20B125
Y12BD2	YM1032	20B120
Y12DD2	YM1034	20B120
Y12BA2	YM1032	20B121
Y12DA2	YM1034	20B121
Y12BM2	YM1032	20B125
Y12DM2	YM1034	20B125

## Y23xxx

Pumps with 5 HP motor and 580 cc lower displacement

Pump Model	Motor	Lower
Y23BD0	YM1052	20B120
Y23DD0	YM1054	20B120
Y23BA0	YM1052	20B121
Y23DA0	YM1054	20B121
Y23BM0	YM1052	20B125
Y23DM0	YM1054	20B125
Y23BD1	YM1052	20B120
Y23DD1	YM1054	20B120
Y23BA1	YM1052	20B121
Y23DA1	YM1054	20B121
Y23BM1	YM1052	20B125
Y23DM1	YM1054	20B125
Y23BD2	YM1052	20B120
Y23DD2	YM1054	20B120
Y23BA2	YM1052	20B121
Y23DA2	YM1054	20B121
Y23BM2	YM1052	20B125
Y23DM2	YM1054	20B125

## Y06xxx

Pumps with 3 HP motor and 1000 cc lower displacement

Pump Model	Motor	Lower
Y06BK0	YM1032	253597
Y06DK0	YM1034	253597
Y06BG0	YM1032	253596
Y06DG0	YM1034	253596
Y06BK1	YM1032	253597
Y06DK1	YM1034	253597
Y06BG1	YM1032	253596
Y06DG1	YM1034	253596
Y06BK2	YM1032	253597
Y06DK2	YM1034	253597
Y06BG2	YM1032	253596
Y06DG2	YM1034	253596

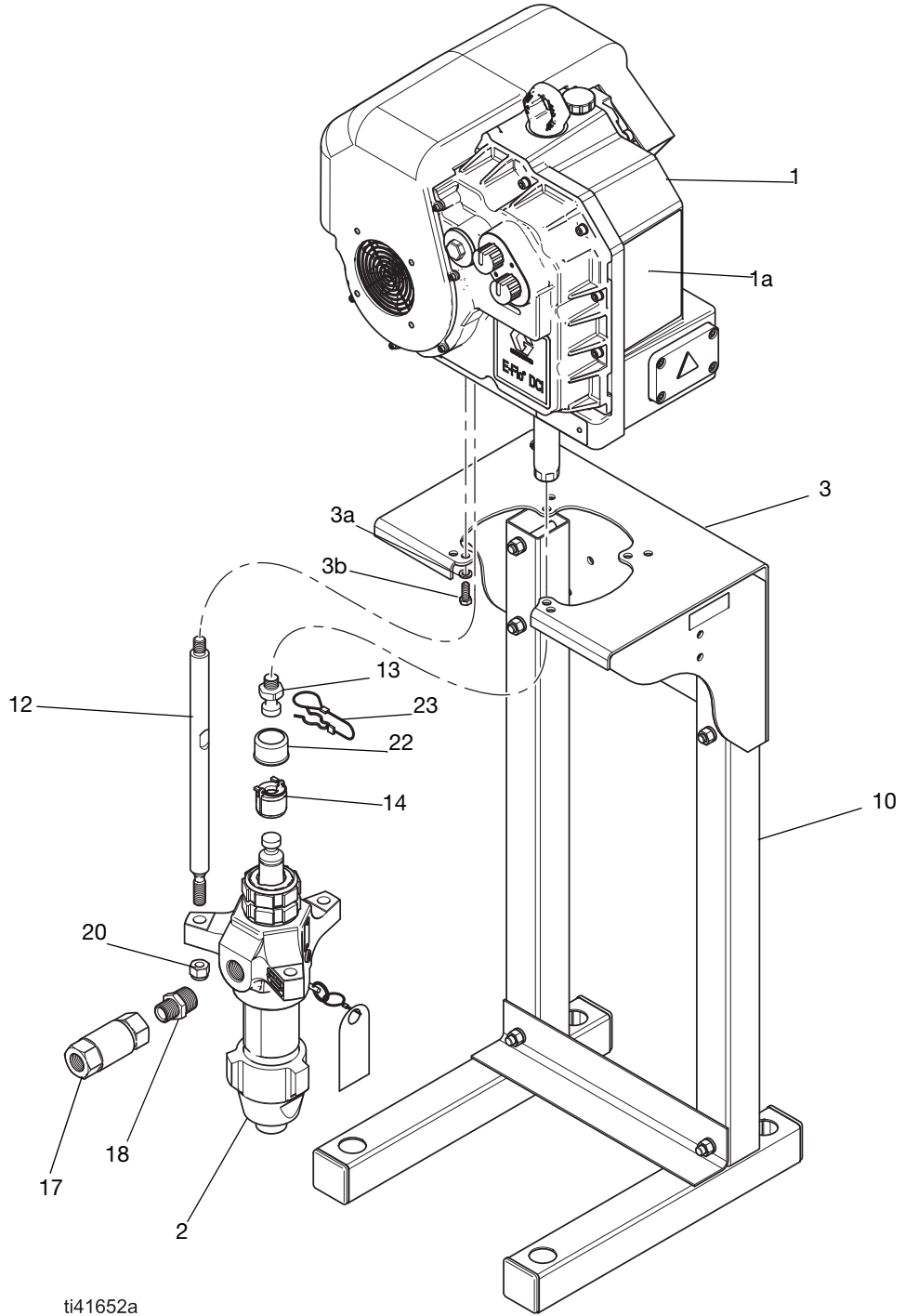
## Y10xxx

Pumps with 5 HP motor and 1000 cc lower displacement

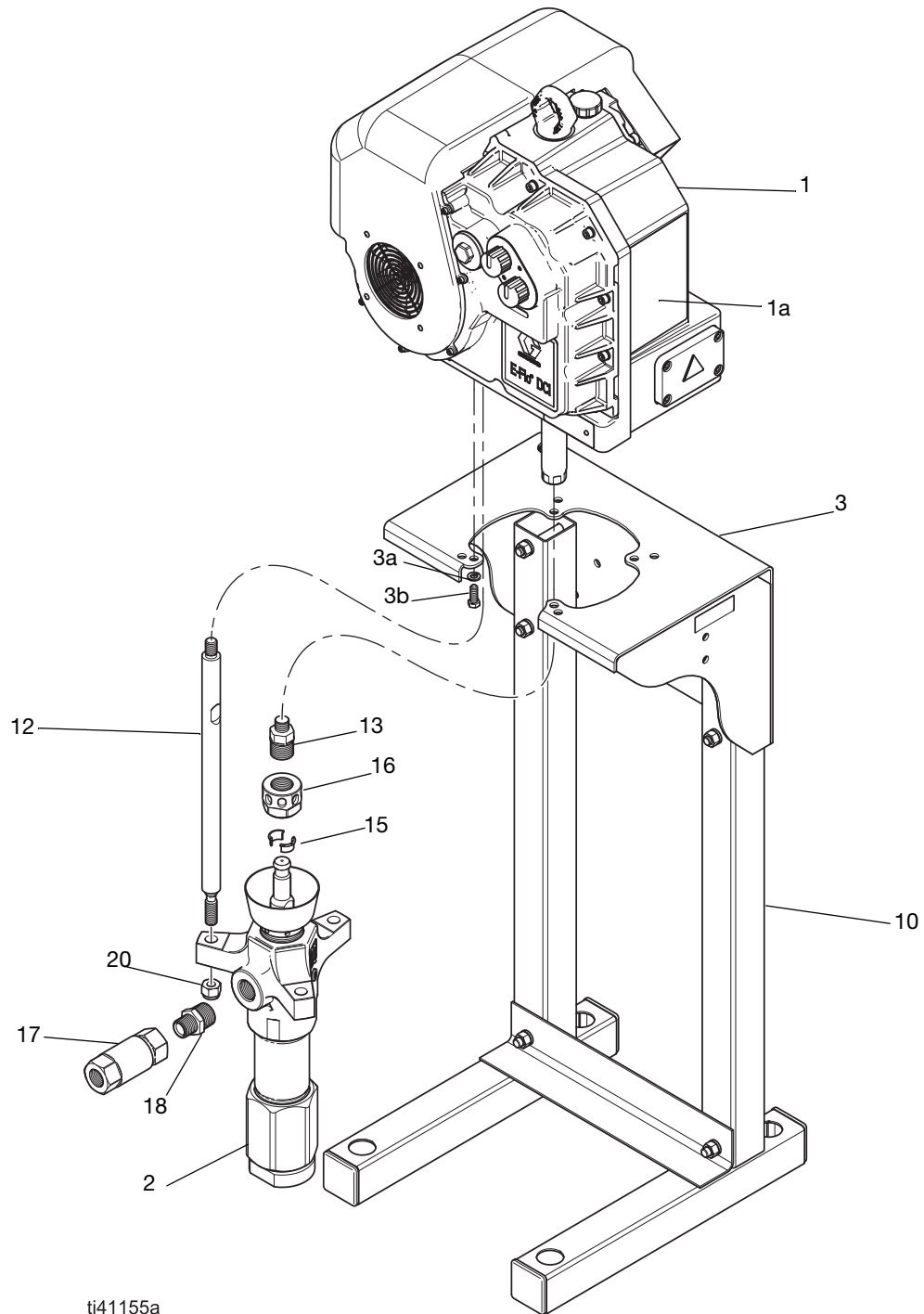
Pump Model	Motor	Lower
Y10BK0	YM1052	253597
Y10DK0	YM1054	253597
Y10BK1	YM1052	253597
Y10DK1	YM1054	253597
Y10BK2	YM1052	253597
Y10DK2	YM1054	253597

# Parts

Y31x1x, Y24x1x, Y70x1x, Y21x1x, Y30x1x, Y60x1x, Y16x1x, Y25x1x



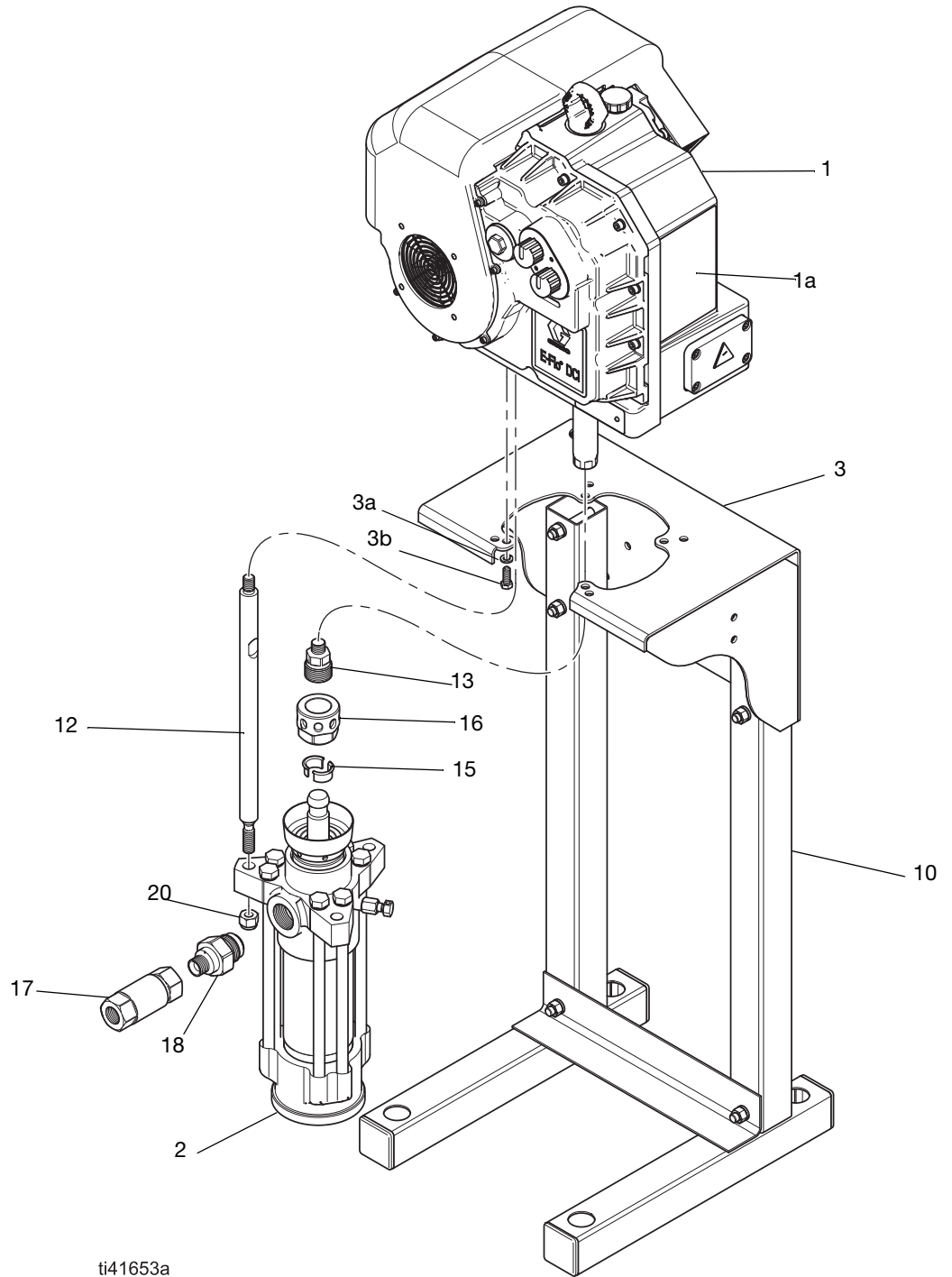
**Y31xHx, Y31xSx, Y46xHx, Y46xSx, Y24xEx, Y40xEx, Y21xEx,  
Y30xEx, Y30xSx, Y57xSx, Y16xEx, Y25xEx, Y45xEx, Y45xSx**



ti41155a

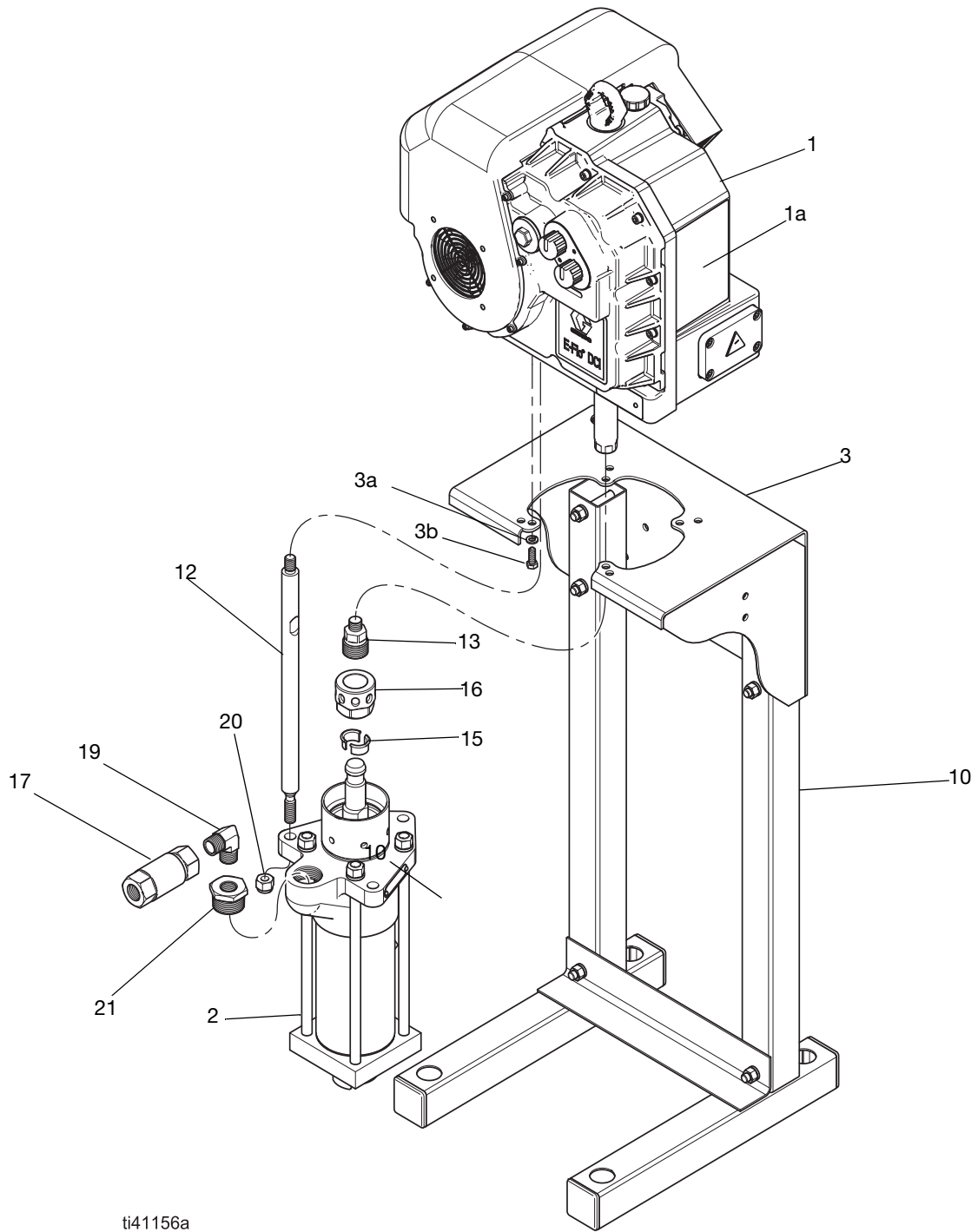


# Y32xxx, Y15xxx, Y12xxx, Y23xxx



ti41653a

# Y06xxx, Y10xxx



ti41156a

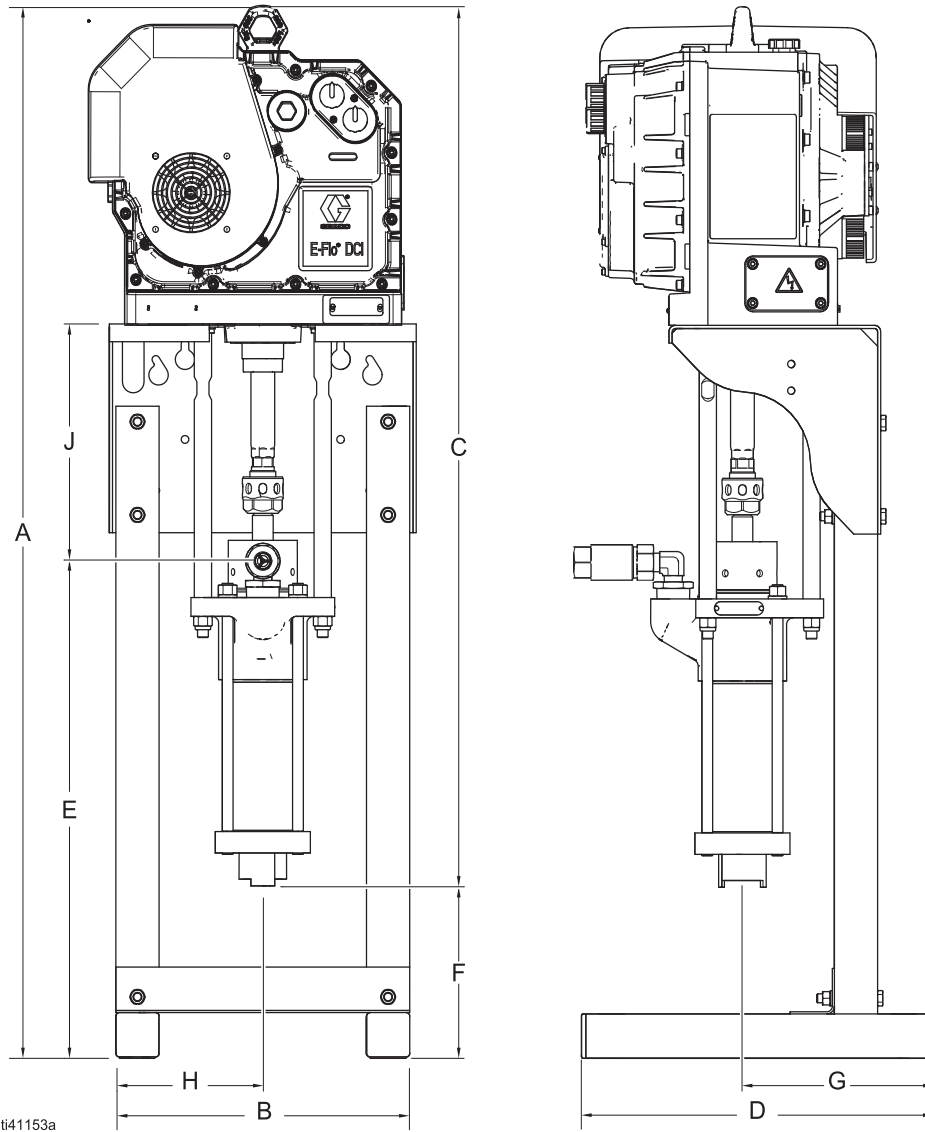
## Parts List

Ref.	Part No.	Description	Qty.
1	-	Motor; see <b>Pump Matrix</b> , page 18 and the motor manual	1
1a▲	20A695	Safety Label	1
2	-	Lower. See <b>Pump Matrix</b> , page 18 and lower manual.	1
3	255143	Mounting Hardware Bracket Kit (includes items 3a and 3b); models Yxxxx1 and Yxxxx2 only	1
3a	-	Washer (included with item 3)	4
3b	-	Bolt (included with item 3)	4
10	256193	Floor Stand; models Yxxxx1 only	1
12		Tie Rod	
	15F837	14.25" length (models Yxxx1x only)	3
	15H562	15.40" length (all models except Yxxx1x)	3
13		Rod Adapter	
	15H370	1 1/4"-12 thread (models Y31xHx, Y31xSx, Y46xxx, Y24xEx, Y40xxx, Y21xEx, Y30xEx, Y30xSx, Y57xxx, Y16xEx, Y25xEx, Y45xxx only)	1
	15H371	M38 x 2 thread (models Y32xxx, Y15xxx, Y12xxx, Y23xxx, Y06xxx, Y10xxx only)	1
	15H392	Xtreme (models Yxxx1x only)	1
14	244819	Assembly Coupling (models Yxxx1x only)	1
15		Collar	
	184129	20.20 inside diameter (models Y31xHx, Y31xSx, Y46xxx, Y24xEx, Y40xxx, Y21xEx, Y30xEx, Y30xSx, Y57xxx, Y16xEx, Y25xEx, Y45xxx only)	2
	184130	25.96 inside diameter (models Y32xxx, Y15xxx, Y12xxx, Y23xxx, Y06xxx, Y10xxx only)	2
16		Coupler	
	184096	2.375" (models Y32xxx, Y15xxx, Y12xxx, Y23xxx, Y06xxx, Y10xxx only)	1
	186925	2.175" (models Y31xHx, Y31xSx, Y46xxx, Y24xEx, Y40xxx, Y21xEx, Y30xEx, Y30xSx, Y57xxx, Y16xEx, Y25xEx, Y45xxx only)	1
17		Check Valve	
	16T480	models Y31x1x, Y24x1x, Y70xxx, Y21x1x, Y30x1x, Y60xxx, Y16x1x, Y25x1x, Y32xDx, Y15xDx, Y15xEx, Y12xDx, Y23xDx, Y06xKx, Y10xxx only	1
	24S039	models Y31xHx, Y31xSx, Y46xxx, Y24xEx, Y40xxx, Y21xEx, Y30xEx, Y30xSx, Y57xxx, Y16xEx, Y25xEx, Y45xxx, Y32xBx, Y32xLx, Y32xMx, Y15xBx, Y15xMx, Y12xAx, Y12xMx, Y23xAx, Y23xMx, Y06xGx only	1
18		Nipple Outlet Fitting	
	171439	Pipe, RDCG (models Y21xxx, Y30xxx, Y57xxx, Y60xxx, Y16xxx, Y25xxx, Y45xxx only)	1
	175013	Pipe (models Y31x1x, Y24x1x, Y70xxx only)	1
	190724	Stainless Steel (models Y31xHx, Y31xSx, Y46xxx, Y24xEx, Y40xxx only)	1
19		Elbow Outlet Fitting	
	121116	3/4 npt m-m rt angle (models Y06xGx only)	1
	295847	90, 3/4 mpt (models Y06xKx, Y10xxx only)	1
20	101712	Lock Nut	3
21		Bushing	
	101496	Pipe (Y06xKx, Y10xxx pumps only)	1
	502851	Hex Head (Y06xGx pumps only)	1
22	197340	Coupling Cover (models Yxxx1x only)	1
23	244820	Hairpin Clip (w/lanyard) (models Yxxx1x only)	1

▲ Replacement safety labels, tags and cards are available at no cost.

# Dimensions

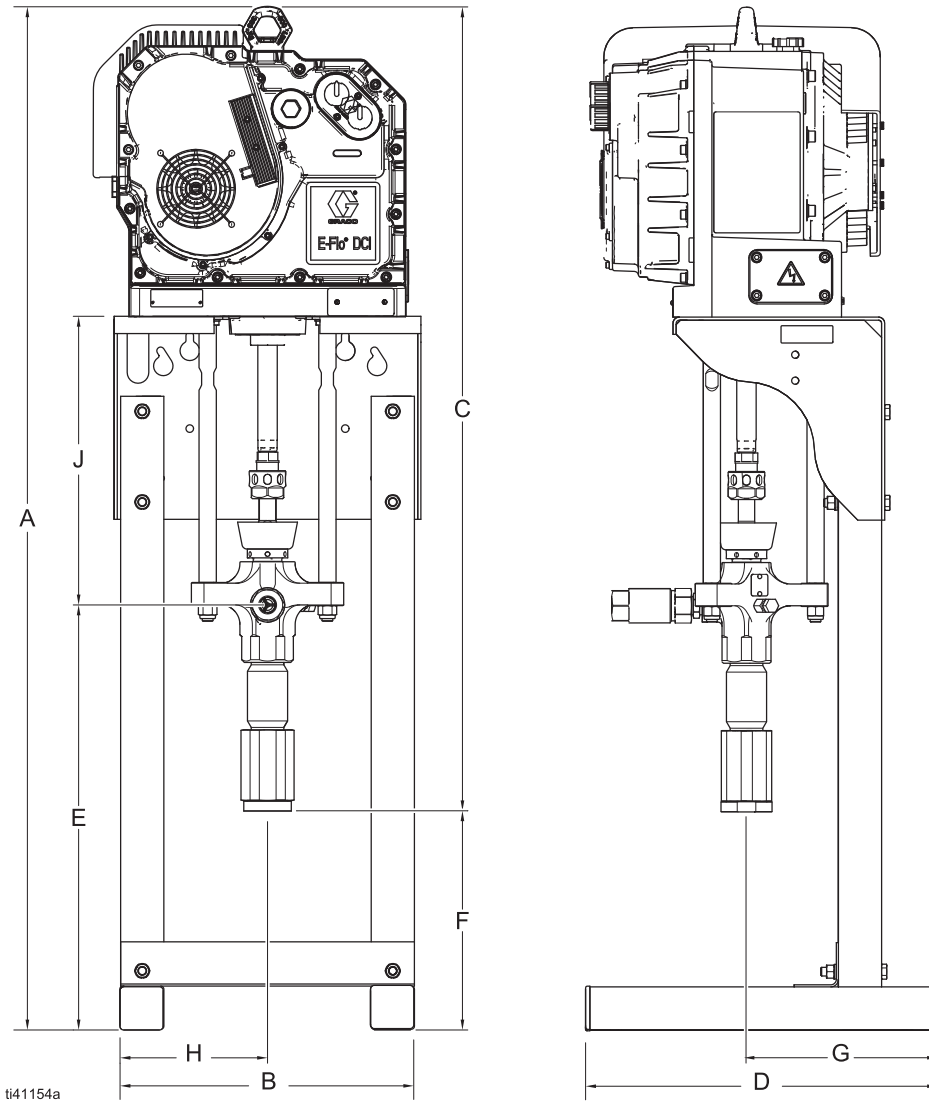
## Y10BK1



tt41153a

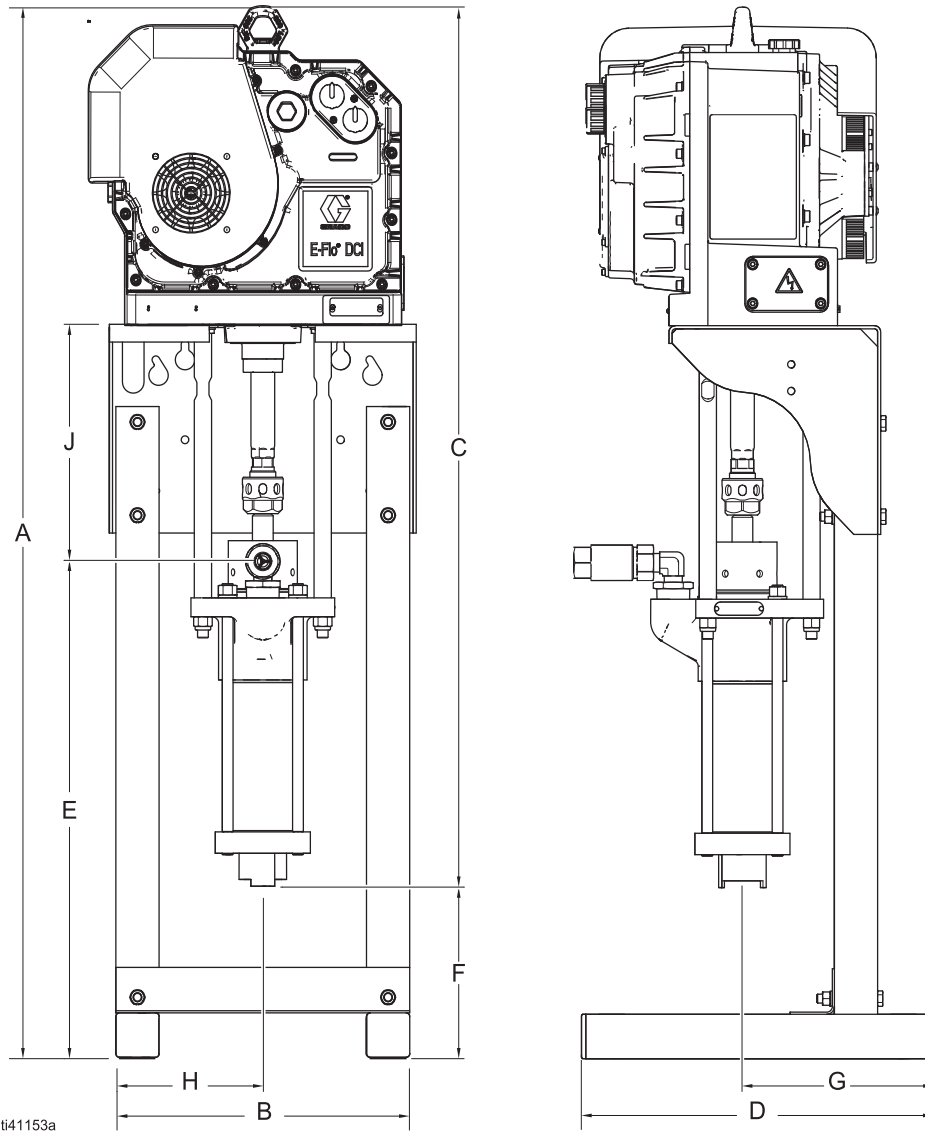
	(in.)	(cm)
A	59.2	150.4
B	17.0	43.2
C	49.6	126.0
D	20.4	51.8
E	27.9	70.9
F	9.6	24.4
G	11.1	28.2

# Y30BE1



	(in.)	(cm)
A	59.2	150.4
B	17.0	43.2
C	47.7	121.2
D	20.4	51.8
E	24.6	62.5
F	11.5	24.4
G	11.1	28.2

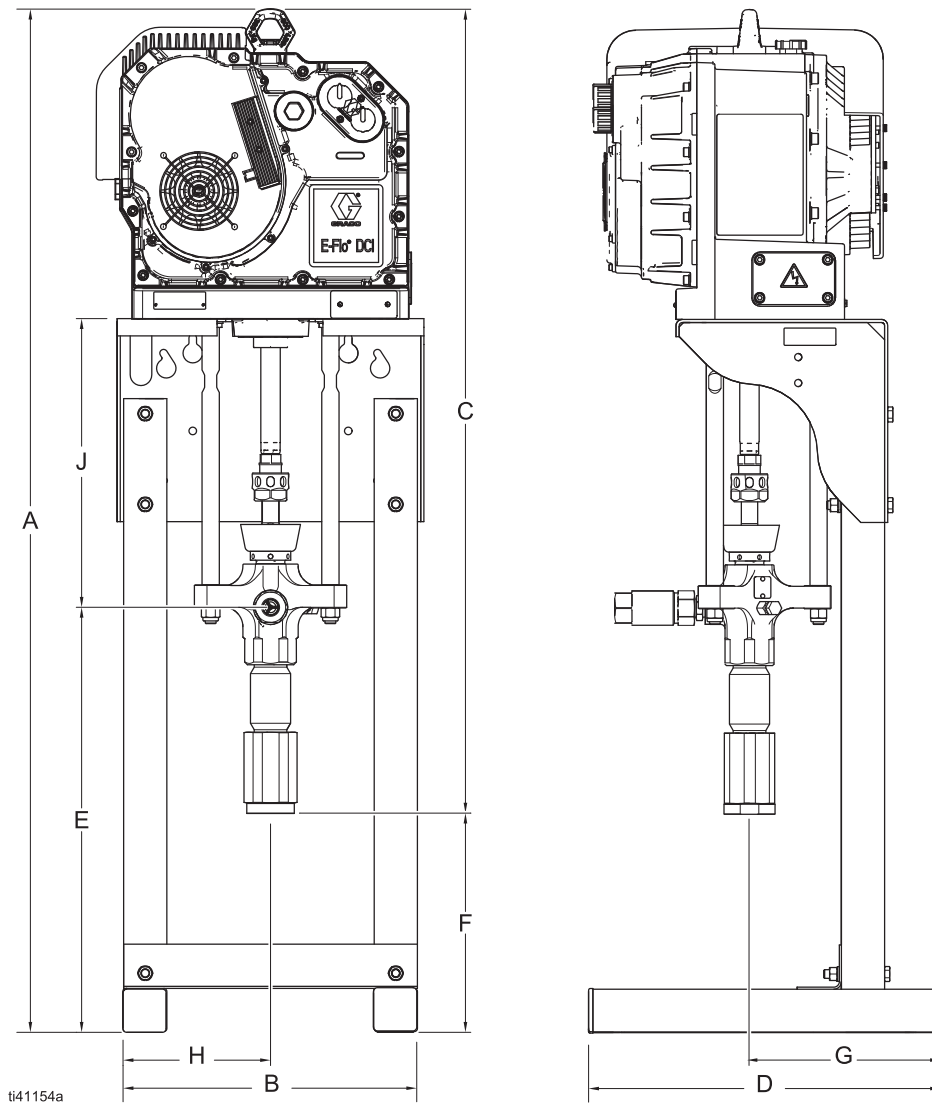
# Y30B11



ti41153a

	(in.)	(cm)
A	59.2	150.4
B	17.0	43.2
C	45.0	114.3
D	20.4	51.8
E	25.8	65.5
F	14.2	36.1
G	11.1	28.2

# Y32BB1



ti41154a

	(in.)	(cm)
A	59.2	150.4
B	17.0	43.2
C	48.5	123.2
D	20.4	51.8
E	24.5	62.2
F	10.7	27.2
G	11.1	28.2

# Performance Charts

To find the fluid pressure (psi/bar/MPa) at a specific fluid flow (gpm/lpm) and percentage of maximum force:

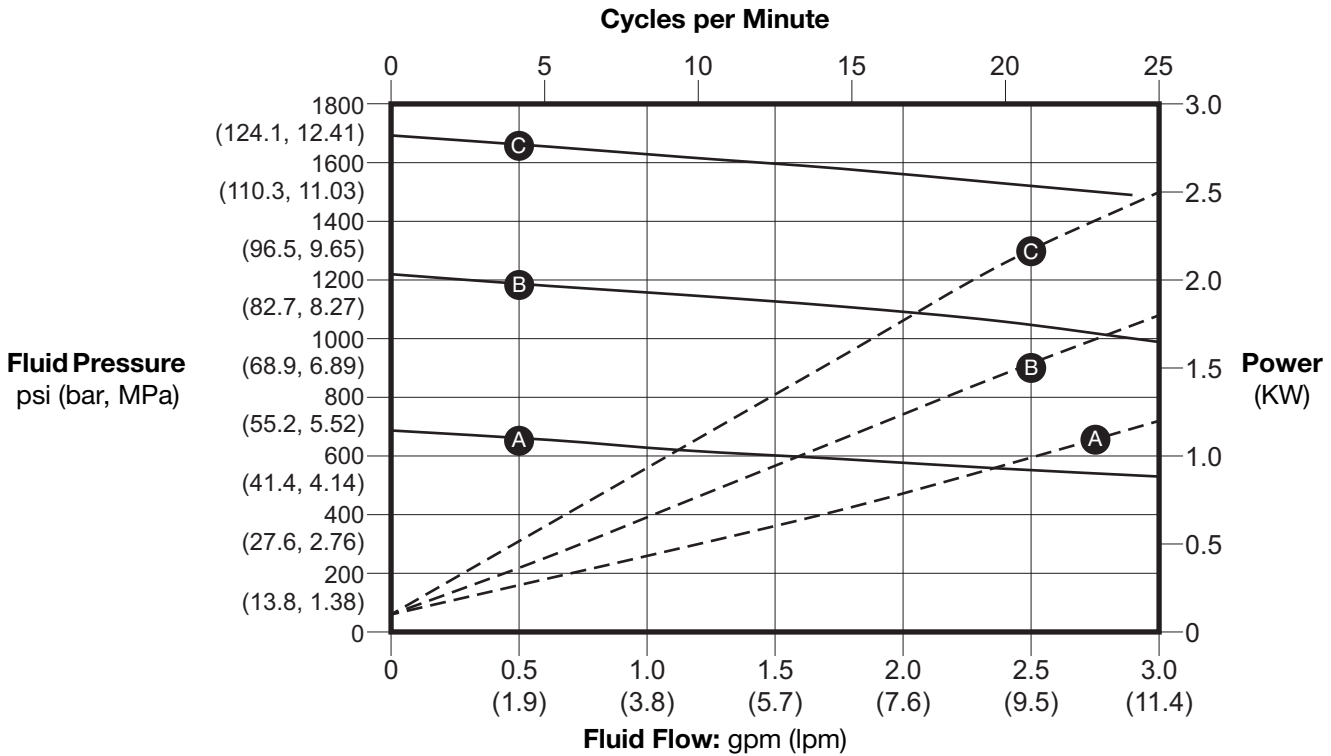
1. Locate the desired fluid flow in the scale at the bottom of the chart.
2. Follow the vertical line up to the intersection with the selected percentage of maximum force.
3. Follow left to the vertical scale to read the fluid outlet pressure.

**Performance Chart Key:**

	Maximum Force Percentage
A	40%
B	70%
C	100%

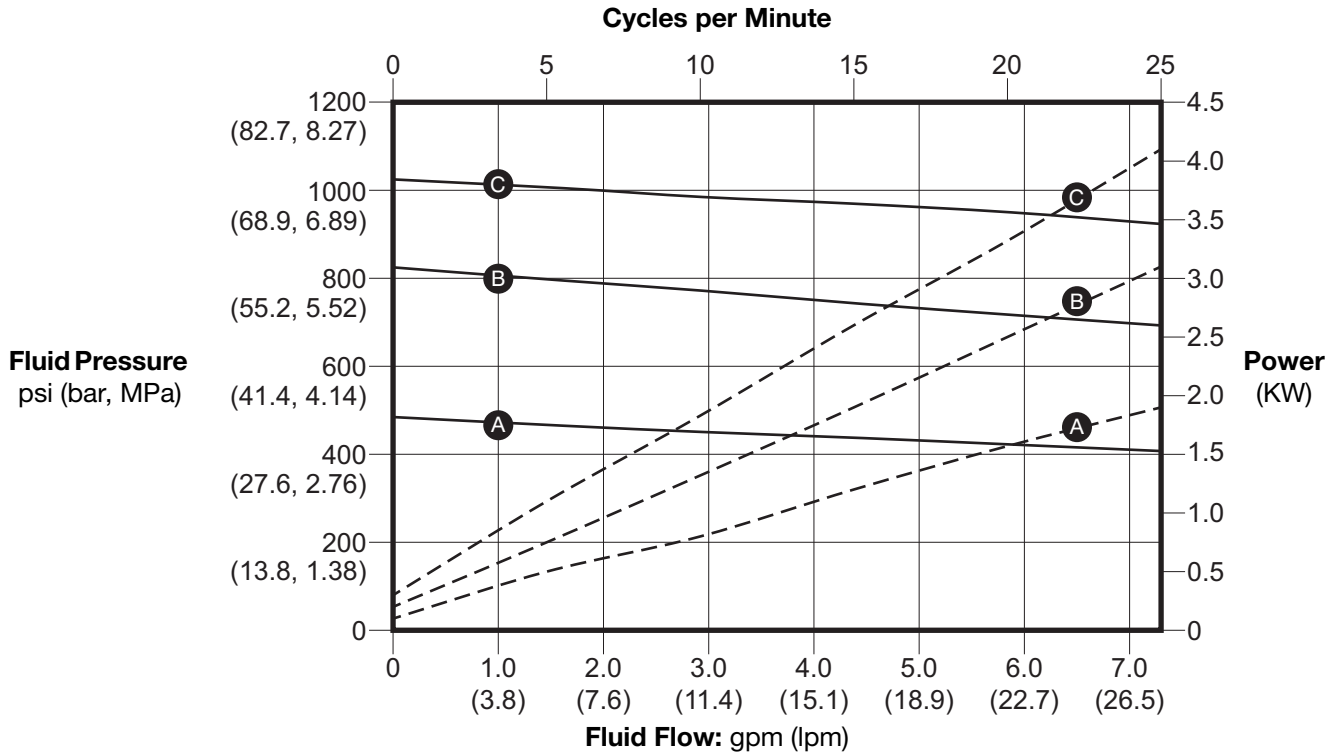
**NOTE:** The charts show the motor operating at 40%, 70%, and 100% of maximum force. These values are approximately equivalent to an air motor operating at 40, 70, and 100 psi. Dashed lines are the power usage at the operating point and motor force. Pumps tested with 10 weight hydraulic oil.

**Y15xxx:** Pumps with 3 HP motors and 430cc lower displacement

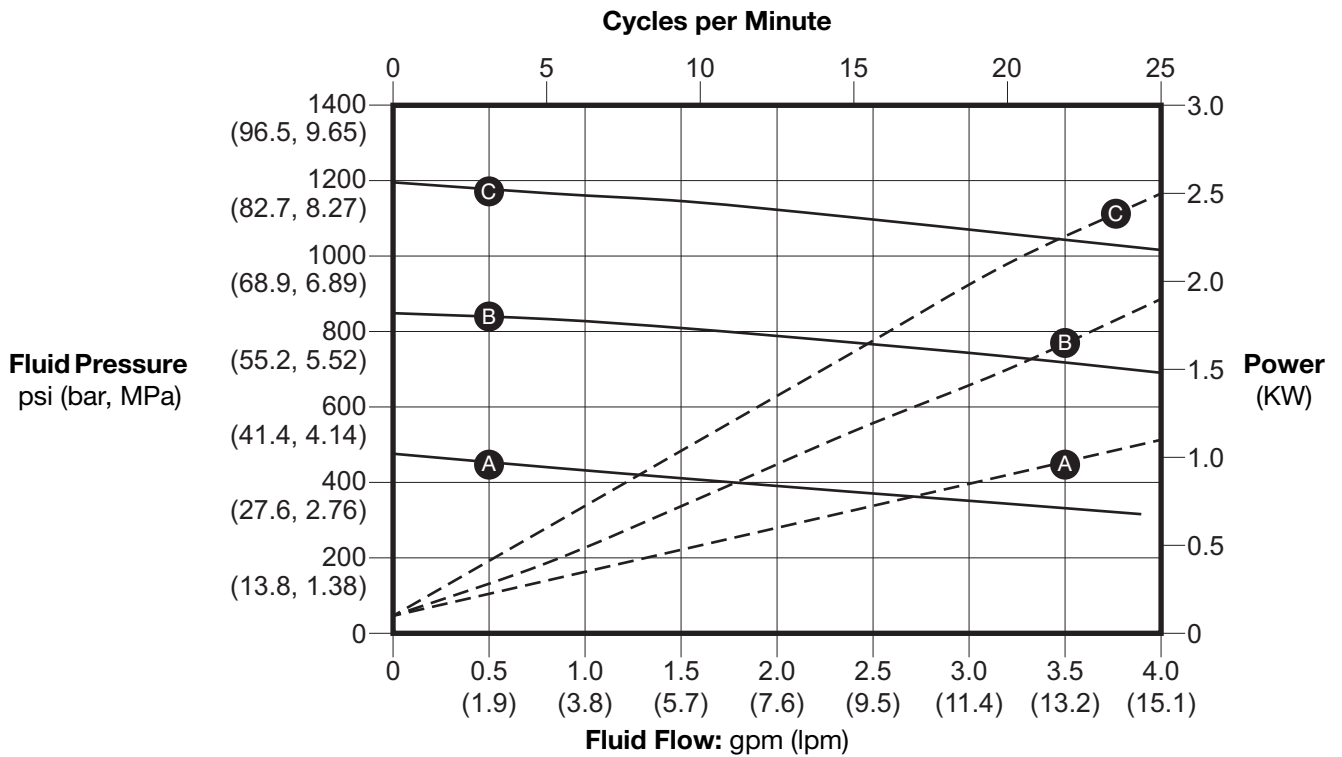




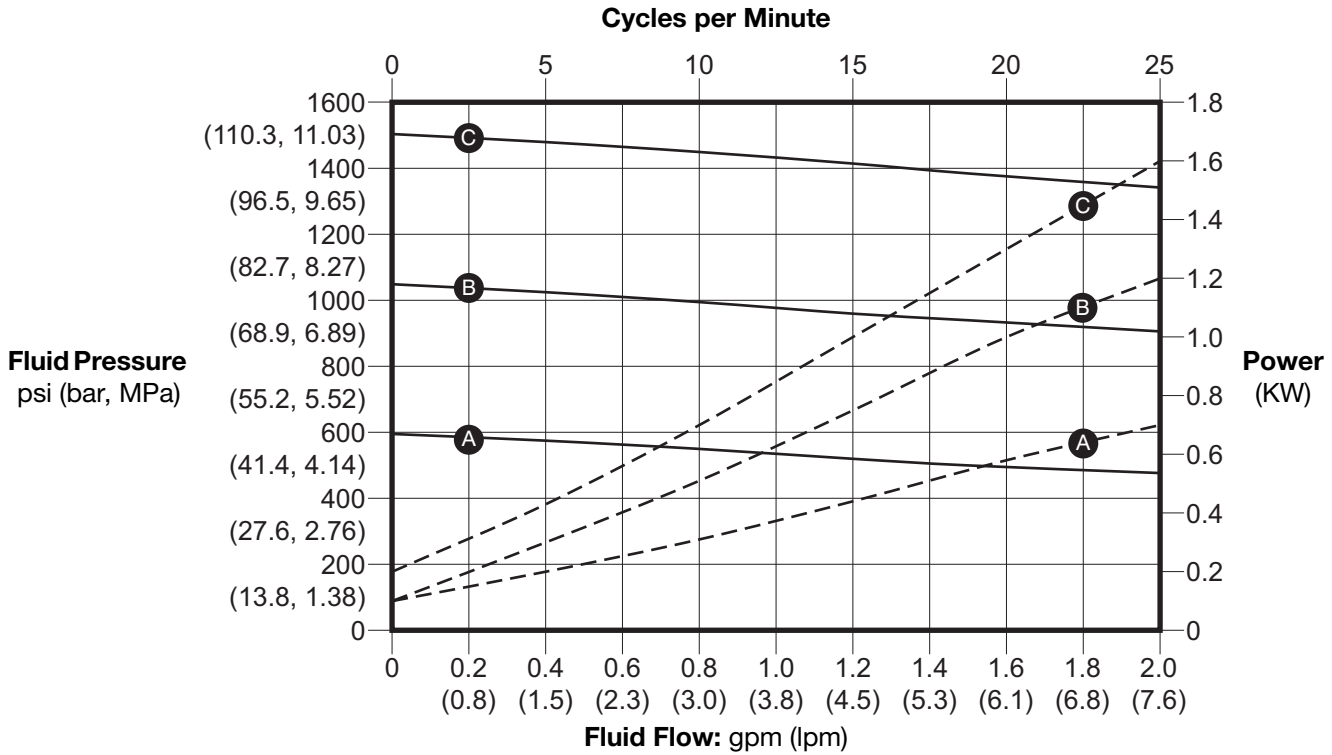
**Y10xxx:** Pumps with 5 HP motor and 1000 cc lower displacement



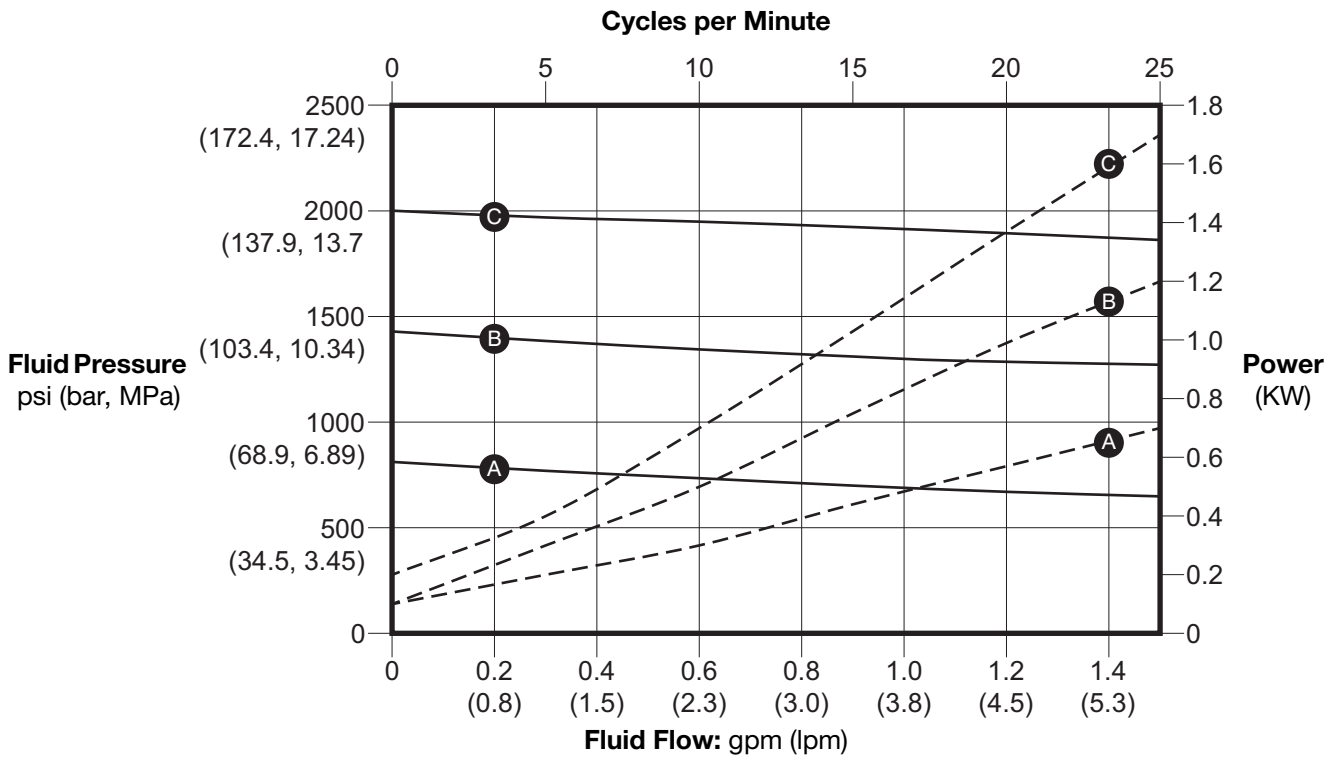
**Y12xxx:** Pumps with 3 HP motor and 580 cc lower displacement



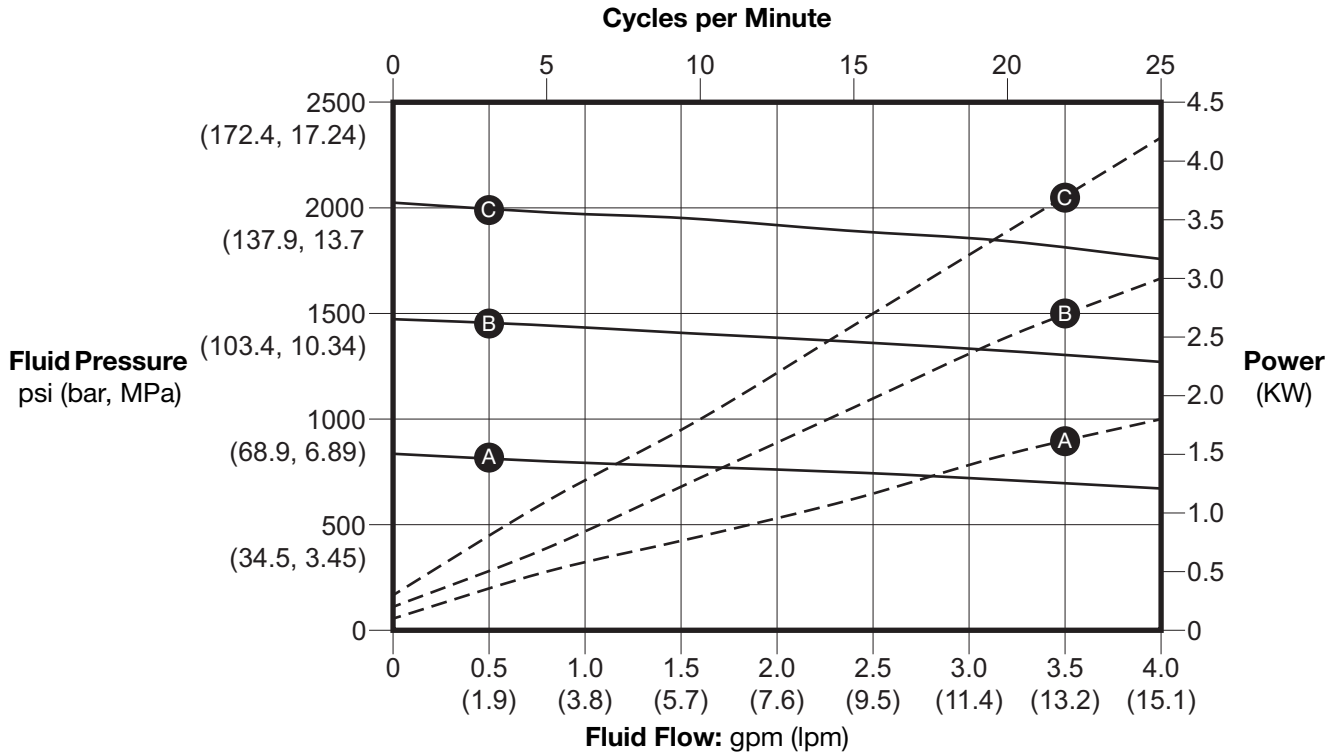
**Y16xxx:** Pumps with 2 HP motor and 290 cc lower displacement



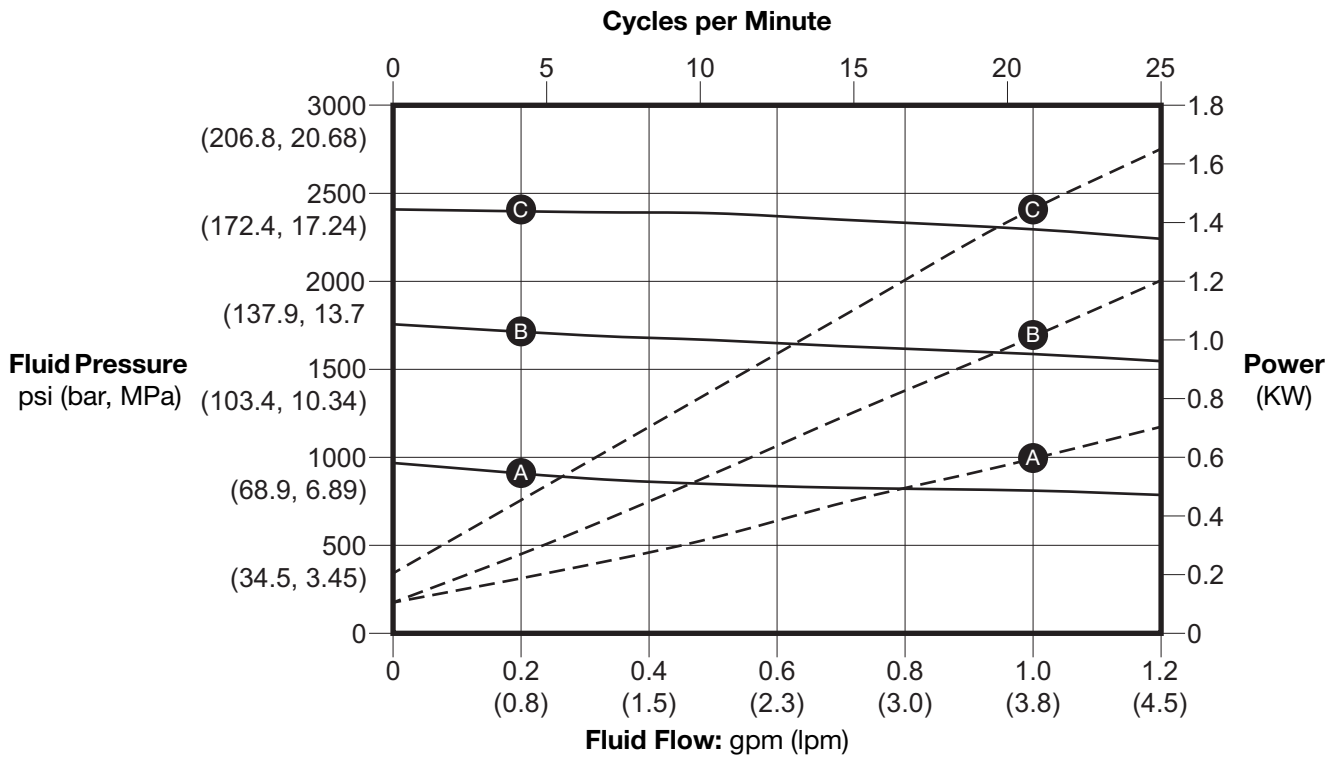
**Y21xxx:** Pumps with 2 HP motor and 220 cc lower displacement



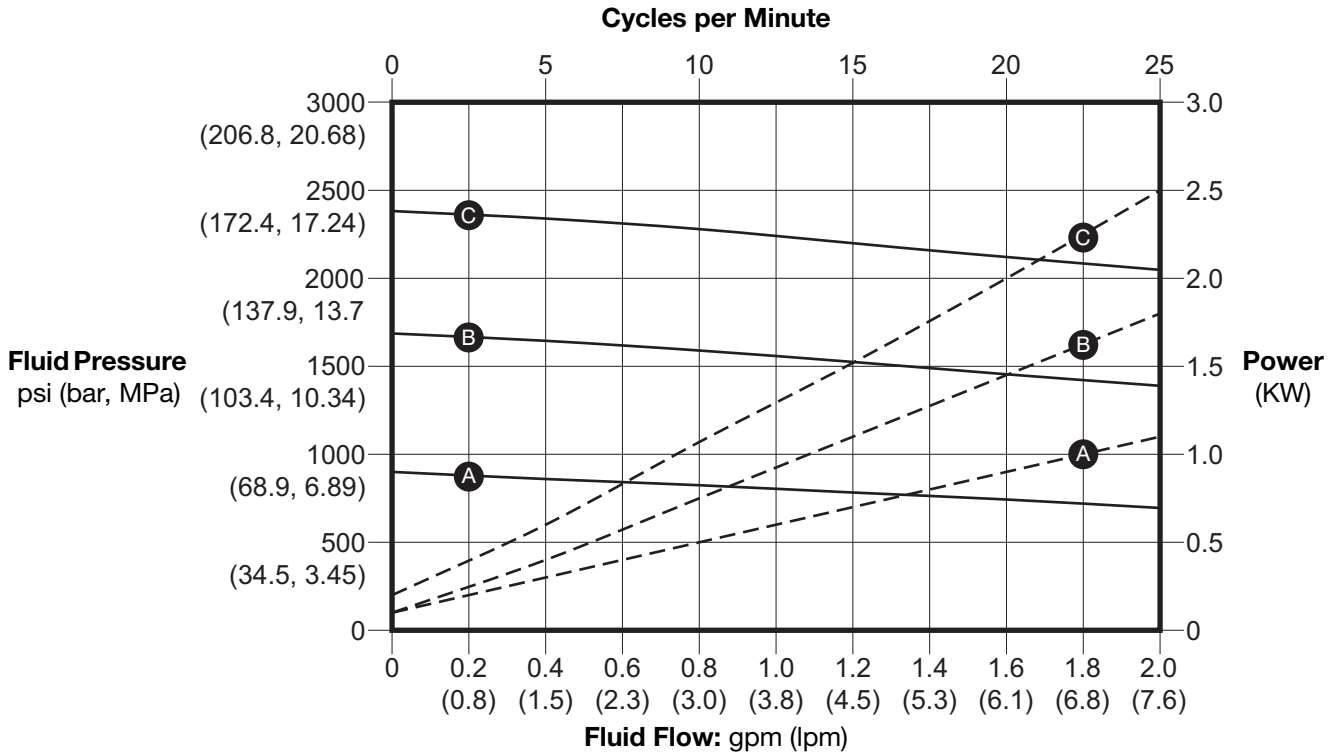
Y23xxx: Pumps with 5 HP motor and 580 cc lower displacement



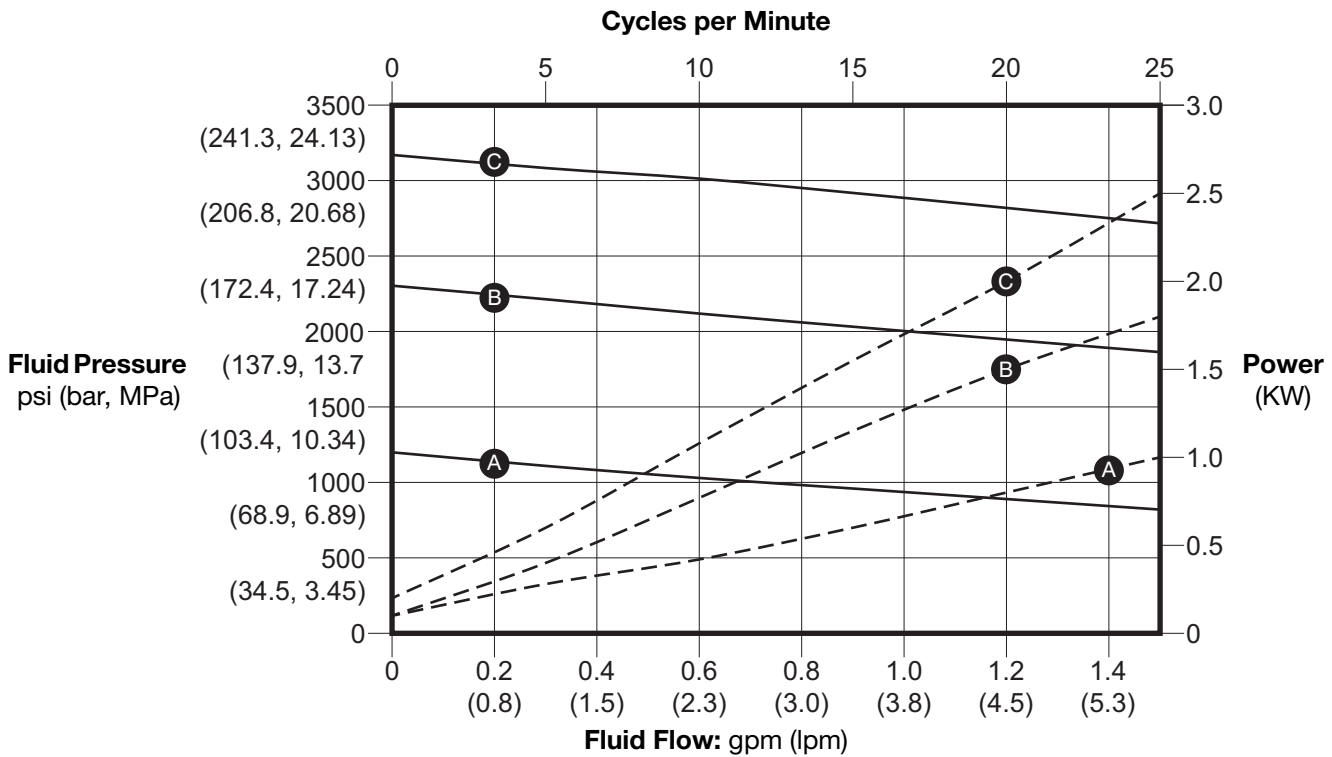
Y24xxx: Pumps with 2 HP motor and 180 cc lower displacement



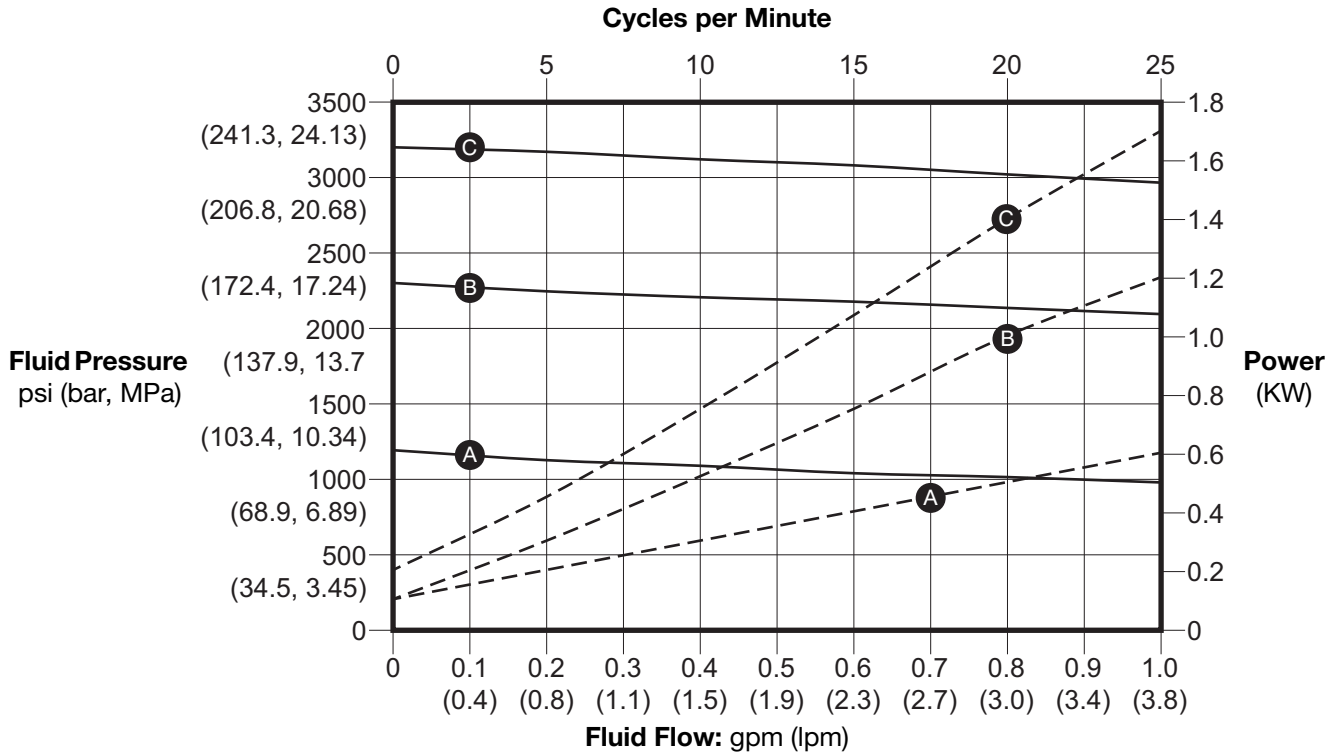
**Y25xxx:** Pumps with 3 HP motor and 290 cc lower displacement



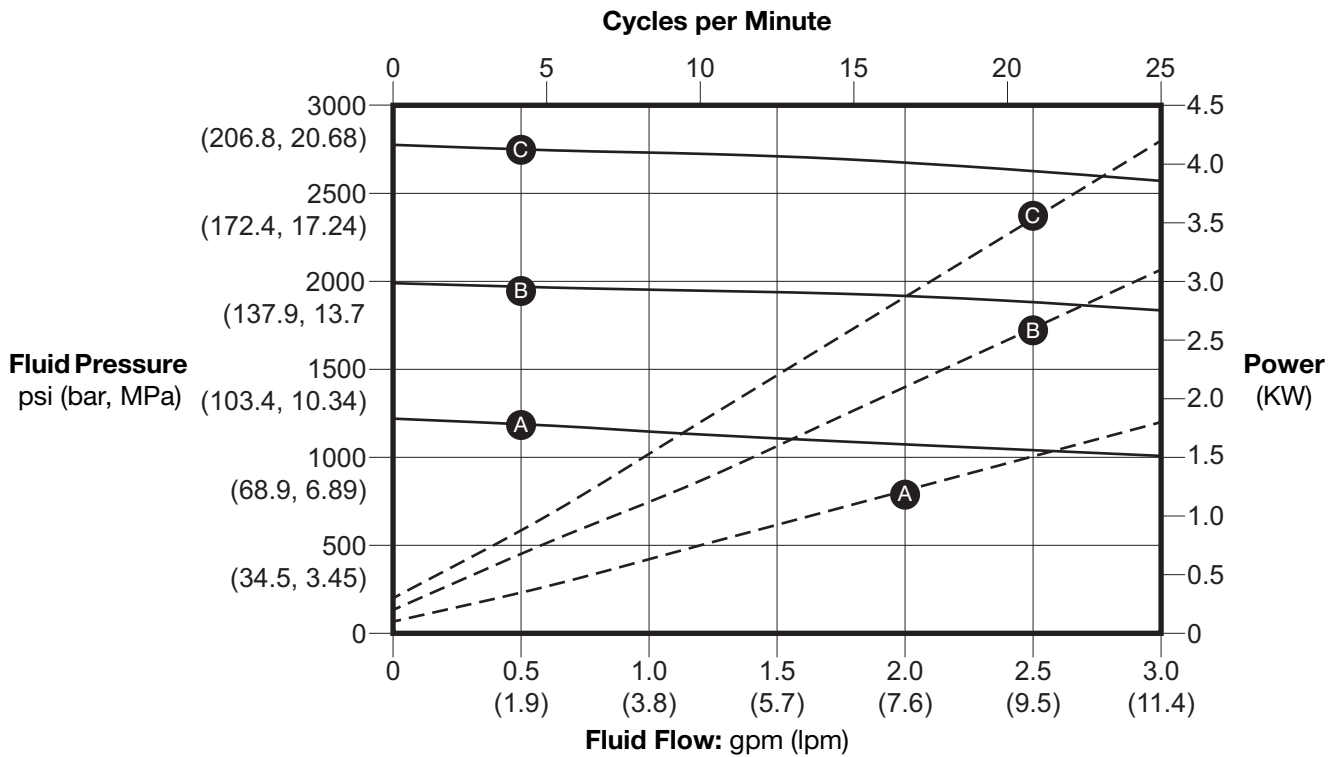
**Y30xxx:** Pumps with 3 HP motor and 220 cc lower displacement



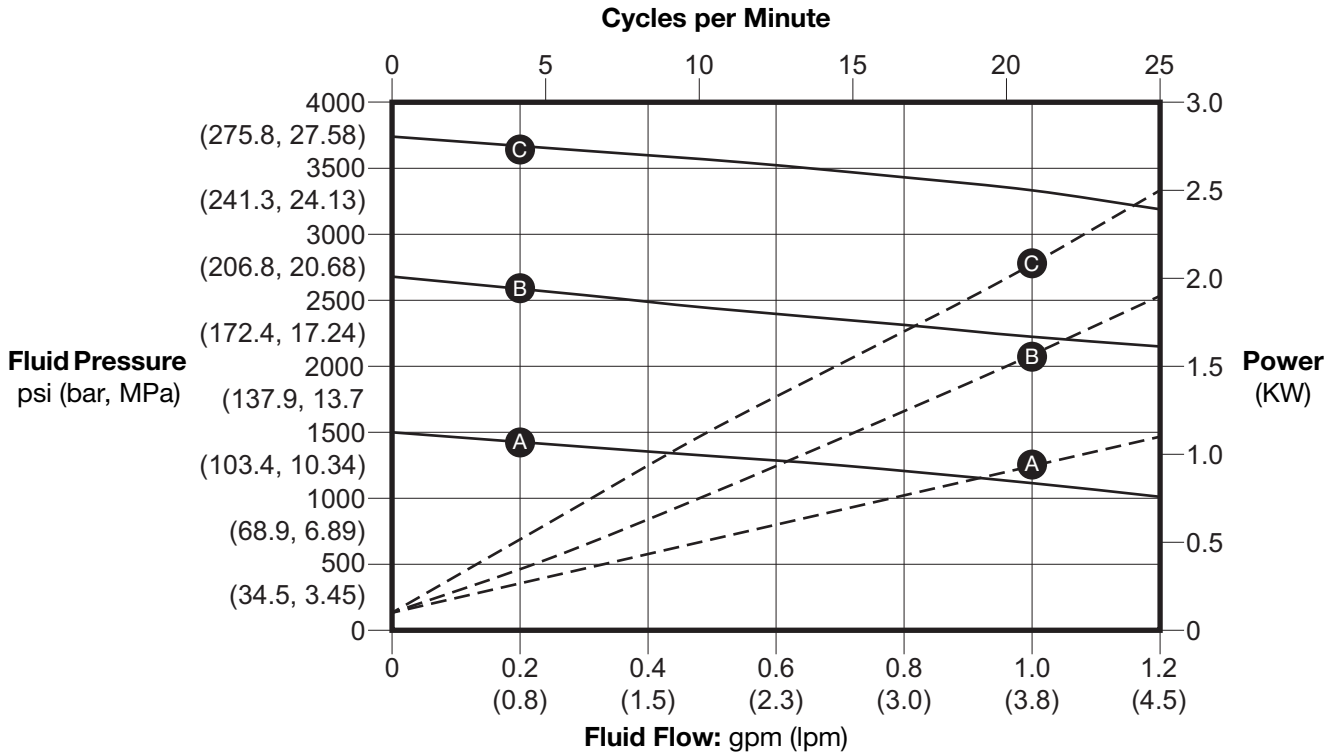
**Y31xxx:** Pumps with 2 HP motor and 145 cc lower displacement



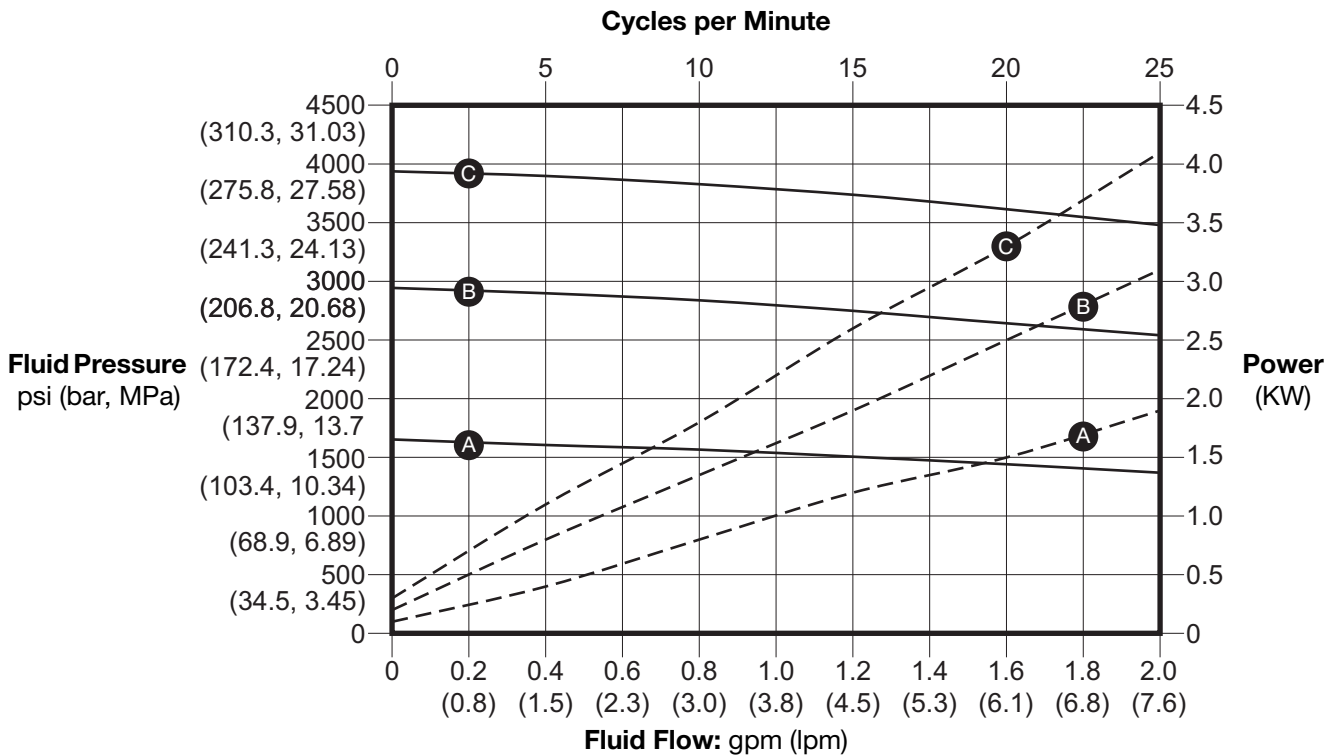
**Y32xxx:** Pumps with 5 HP motor and 430 cc lower displacement



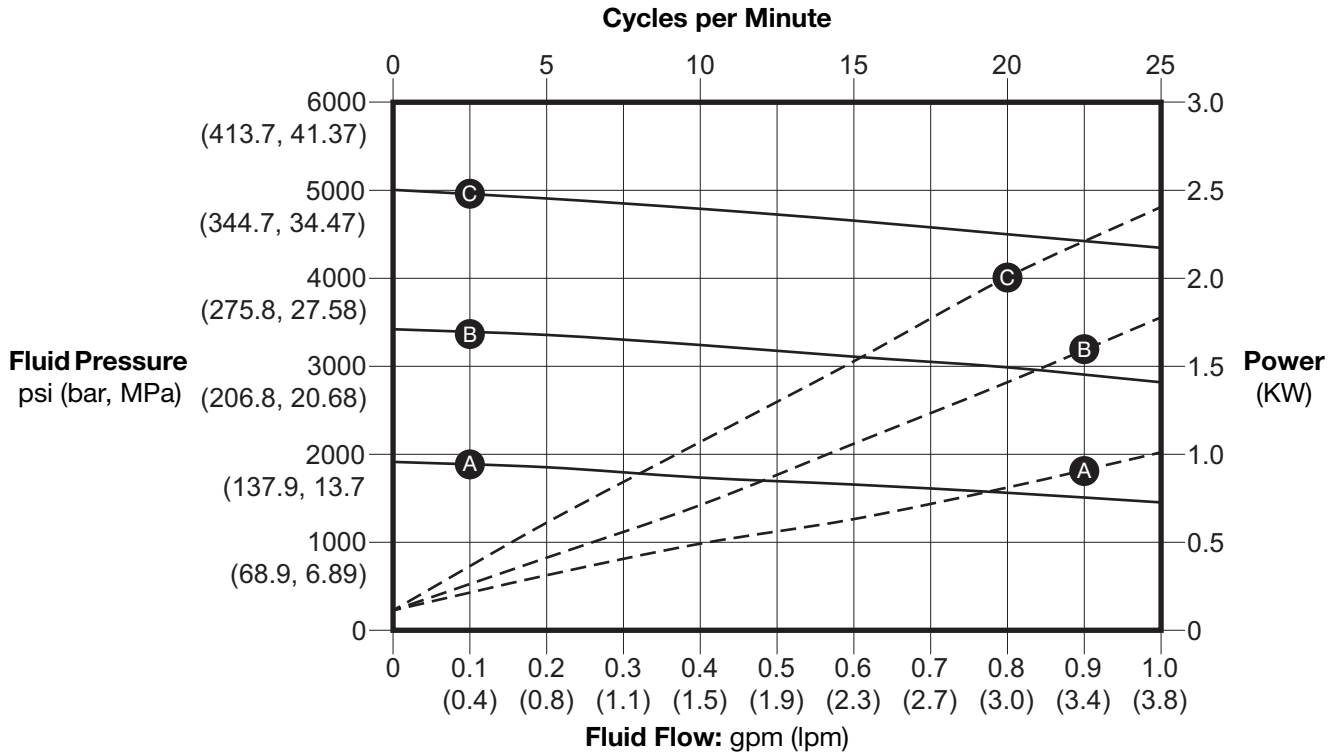
**Y40xxx:** Pumps with 3 HP motor and 180 cc lower displacement



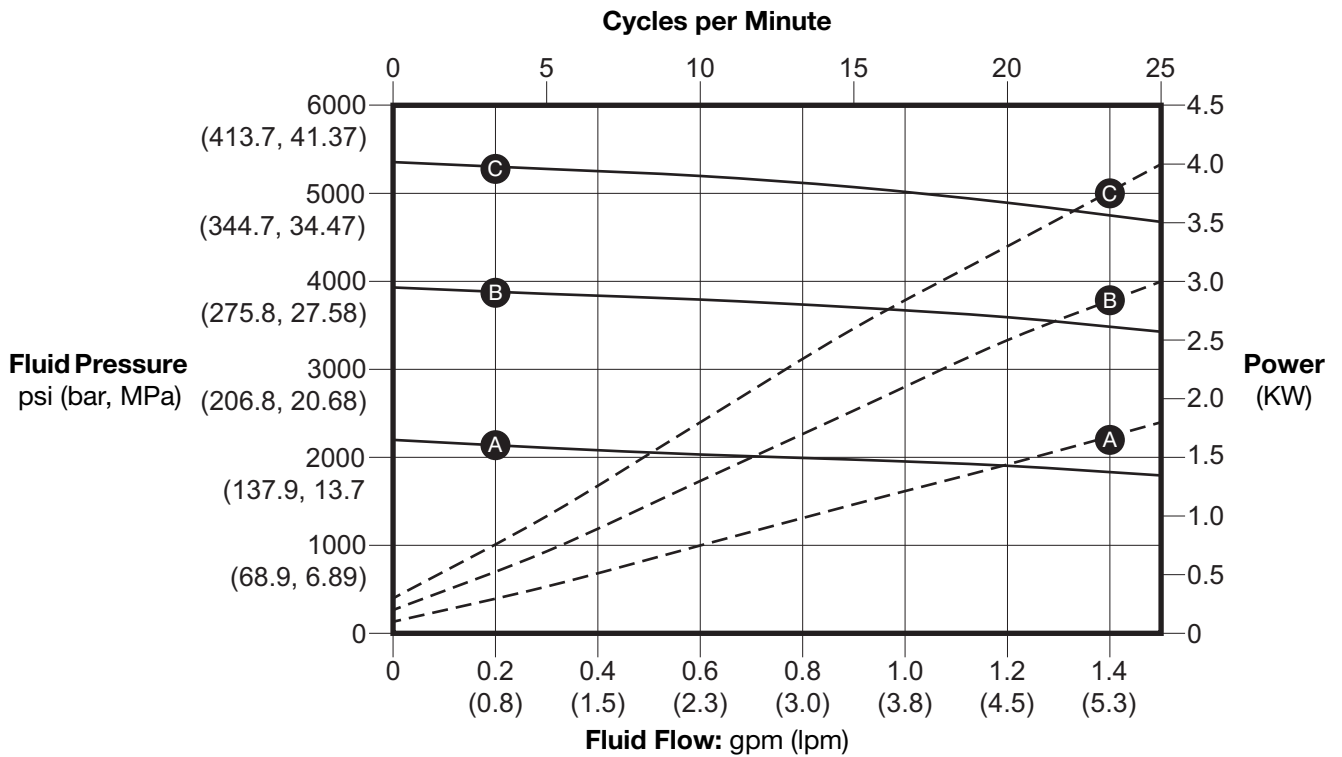
**Y45xxx:** Pumps with 5 HP motor and 290 cc lower displacement



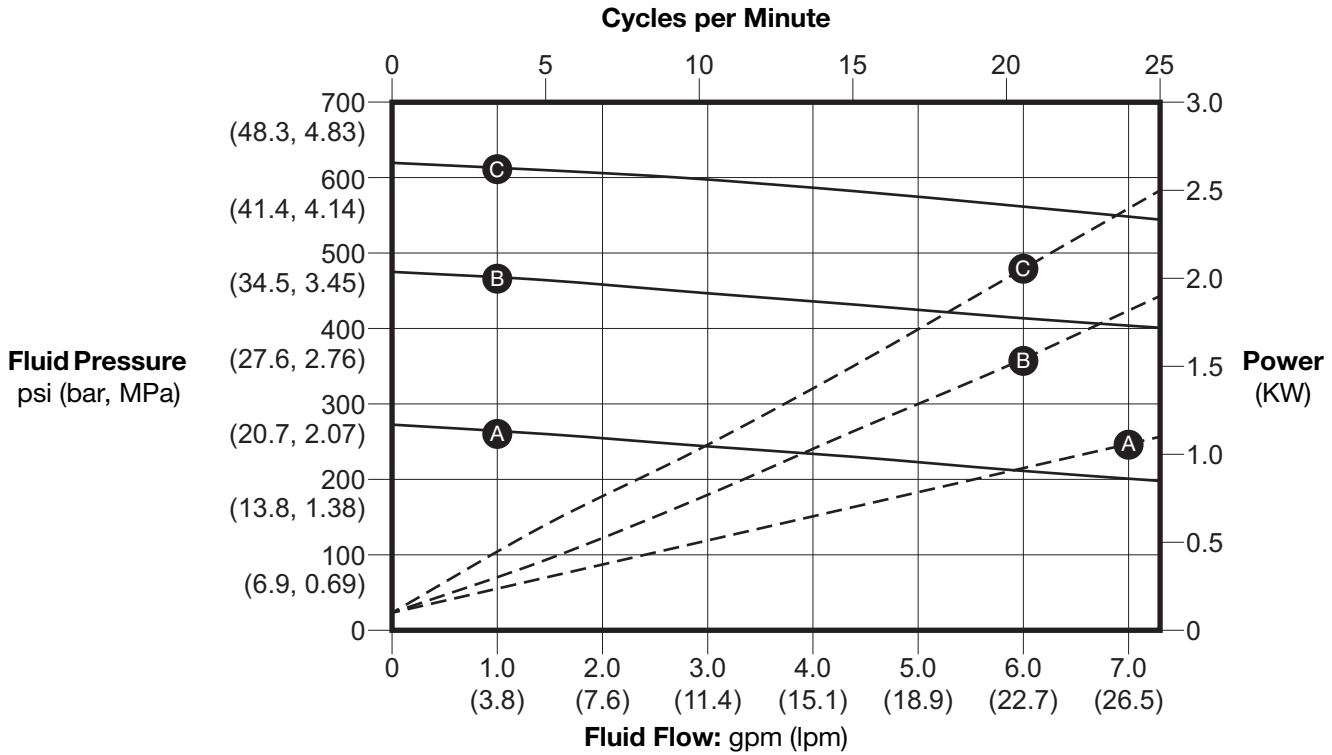
**Y46xxx:** Pumps with 3 HP motor and 145 cc lower displacement



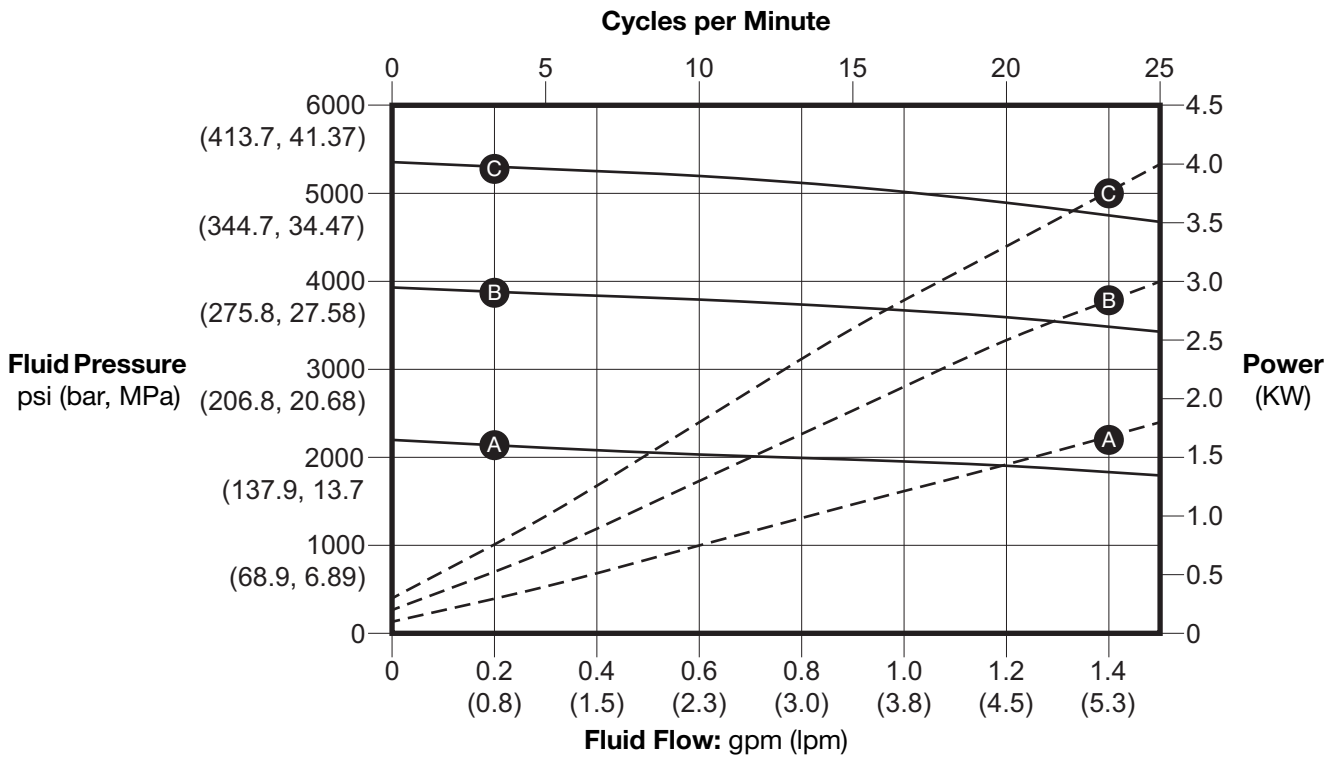
**Y57xxx:** Pumps with 5 HP motor and 220 cc lower displacement



**Y06xxx:** Pumps with 3 HP motor and 1000 cc lower displacement

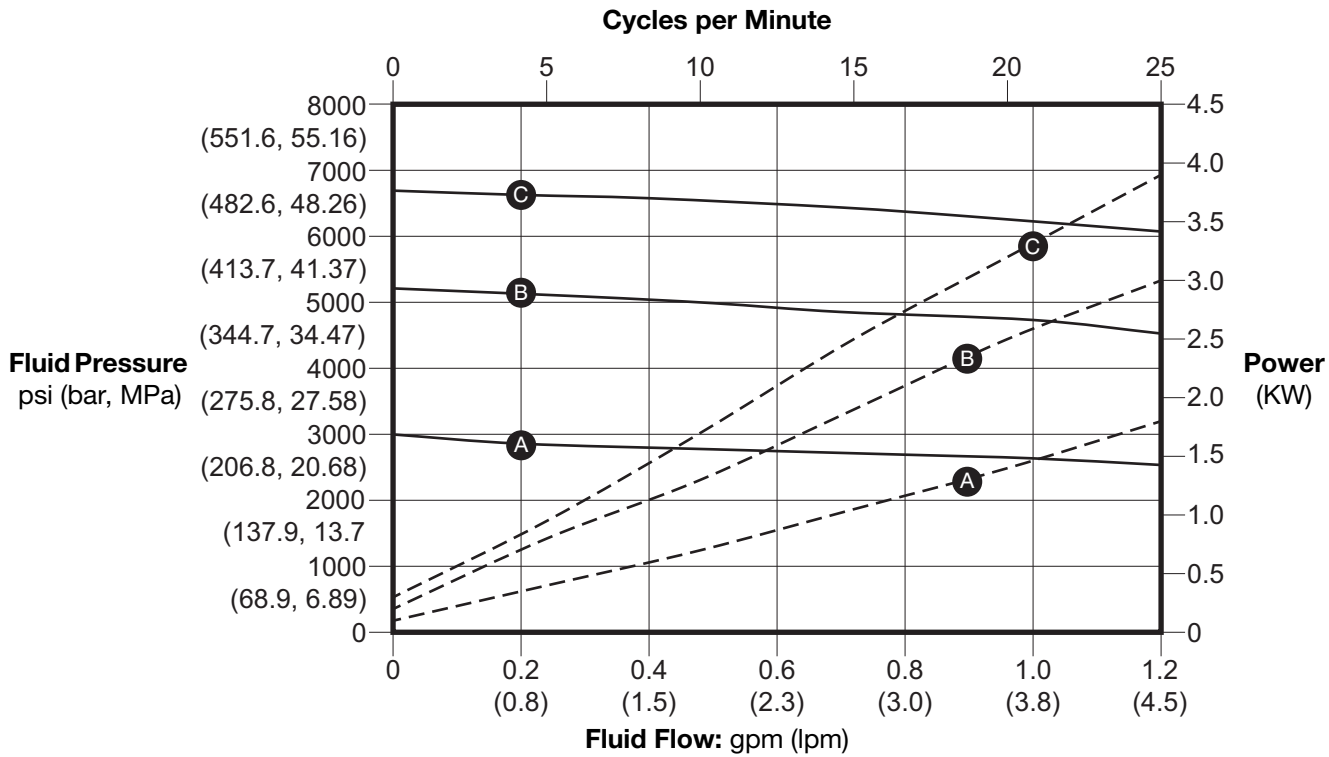


**Y60xxx:** Pumps with 5 HP motor and 220 cc lower displacement



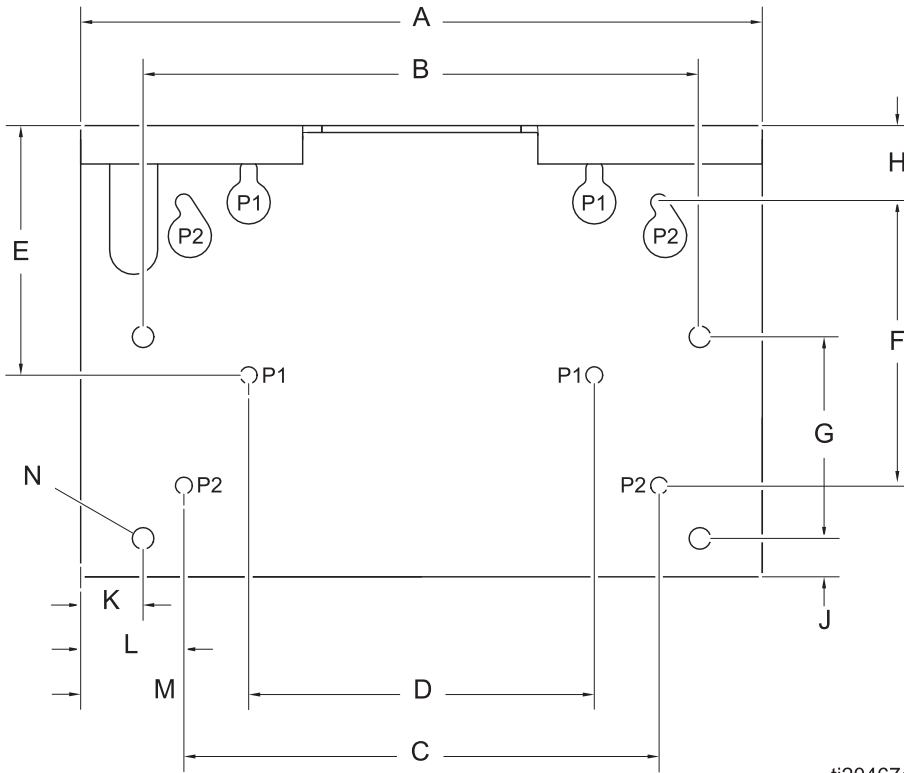


Y70xxx: Pumps with 5 HP motor and 180 cc lower displacement



# Mounting Hole Patterns

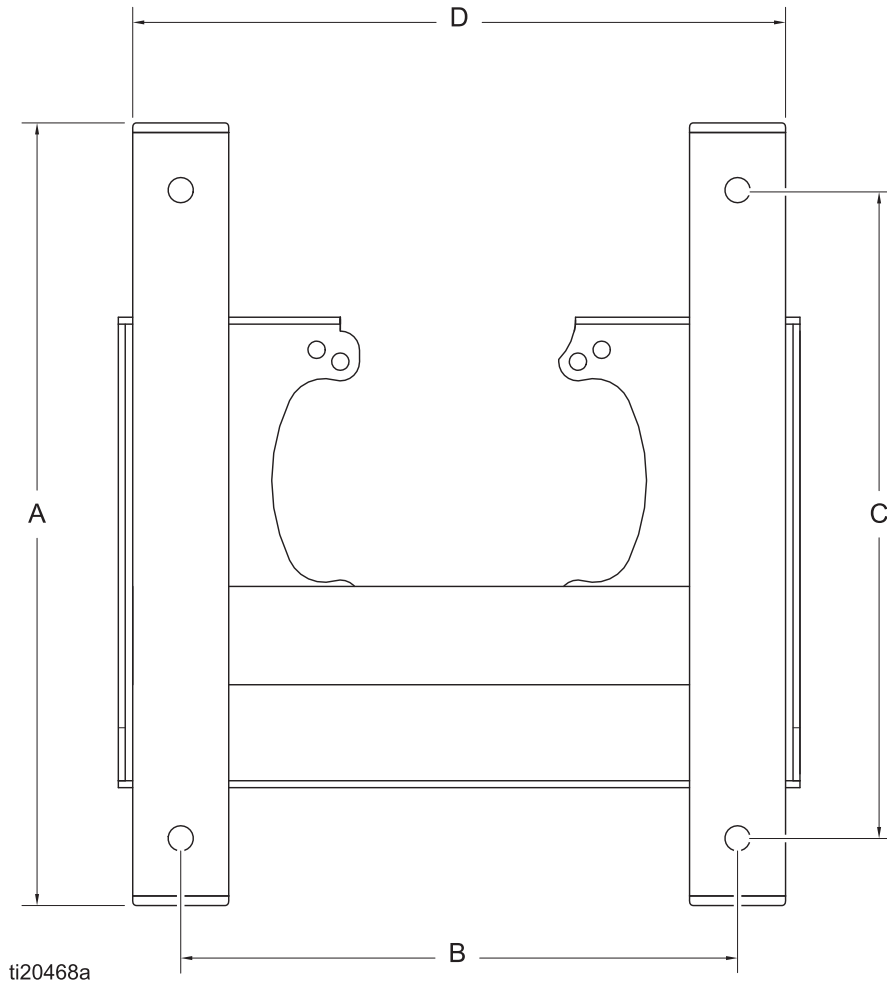
## Mounting Bracket Pattern



ti20467a

<b>A</b>	17.8 in. (451 mm)
<b>B</b>	14.5 in. (368 mm)
<b>C</b>	12.4 in. (314 mm)
<b>D</b>	9.0 in. (229 mm)
<b>E</b>	5.4 in. (137 mm)
<b>F</b>	7.4 in. (187 mm)
<b>G</b>	5.3 in. (133 mm)
<b>H</b>	2.0 in. (51 mm)
<b>J</b>	1.0 in. (25 mm)
<b>K</b>	1.6 in. (41 mm)
<b>L</b>	2.7 in. (69 mm)
<b>M</b>	4.4 in. (112 mm)
<b>N</b>	Four 0.562 in. (14 mm) diameter holes for mounting to stand
<b>P</b>	Four 0.438 in. (11 mm) diameter holes for mounting to wall

## Floor Stand Mounting Pattern



<b>A</b>	19.88 in. (505.0 mm)
<b>B</b>	14.50 in. (368.3 mm)
<b>C</b>	16.88 in. (428.8 mm)
<b>D</b>	17.0 in. (431.8 mm)

# Technical Specifications

## E-Flo DCi 2-Ball Pumps

Models	Motor Rating	Lower Displacement	Flow Rate at 20 cpm	Maximum Fluid Working Pressure	Pump Weight	Fluid Inlet Connection	Fluid Outlet Connection
Y31xxx	2 HP (1.49 kW) 2.7 kVA 380–480 Vac 3 phase 50/60 Hz	145 cc	0.8 gpm (2.9 lpm)	3100 psi (214 bar, 21.4 mPa)	w/CS Lower 212 lb (96 kg) w/SS Lower 203 lb (92 kg)	1 1/4" NPT (m) CS Lower 1 1/2" NPT (f) SS Lower	3/4" NPT (f)
Y46xxx	3 HP (2.24 kW) 3.4 kVA 380–480 Vac 3 phase 50/60 Hz	145 cc	0.8 gpm (2.9 lpm)	4800 psi (331 bar, 33.1 mPa)	205 lb (93 kg)	1 1/4" NPT (m) CS Lower 1 1/2" NPT (f) SS Lower	3/4" NPT (f)
Y24xxx	2 HP (1.49 kW) 2.7 kVA 380–480 Vac 3 phase 50/60 Hz	180 cc	1.0 gpm (3.6 lpm)	2400 psi (165 bar, 16.5 mPa)	w/CS Lower 212 lb (96 kg) w/SS Lower 204 lb (93 kg)	1 1/4" NPT (m) CS Lower 1 1/2" NPT (f) SS Lower	3/4" NPT (f)
Y40xxx	3 HP (2.24 kW) 3.4 kVA 380–480 Vac 3 phase 50/60 Hz	180 cc	1.0 gpm (3.6 lpm)	3800 psi (262 bar, 26.2 mPa)	206 lb (93 kg)	1 1/4" NPT (m) CS Lower 1 1/2" NPT (f) SS Lower	3/4" NPT (f)
Y70xxx	5 HP (3.73 kW) 5.7 kVA 380–480 Vac 3 phase 50/60 Hz	180 cc	1.0 gpm (3.6 lpm)	6800 psi (469 bar, 46.9 mPa)	222 lb (101 kg)	1 1/4" NPT (m) CS Lower 1 1/2" NPT (f) SS Lower	3/4" NPT (f)
Y21xxx	2 HP (1.49 kW) 2.7 kVA 380–480 Vac 3 phase 50/60 Hz	220 cc	1.2 gpm (4.3 lpm)	2100 psi (145 bar, 14.5 mPa)	w/CS Lower 216 lb (98 kg) w/SS Lower 237 lb (108 kg)	1 1/4" NPT (m) CS Lower 2" NPT (f) SS Lower	3/4" NPT (f)

<b>Models</b>	<b>Motor Rating</b>	<b>Lower Displacement</b>	<b>Flow Rate at 20 cpm</b>	<b>Maximum Fluid Working Pressure</b>	<b>Pump Weight</b>	<b>Fluid Inlet Connection</b>	<b>Fluid Outlet Connection</b>
Y30xxx	3 HP (2.24 kW) 3.4 kVA 380–480 Vac 3 phase 50/60 Hz	220 cc	1.2 gpm (4.3 lpm)	3200 psi (221 bar, 22.1 mPa)	w/CS Lower 218 lb (99 kg) w/SS Lower 239 lb (108 kg)	1 1/4" NPT (m) CS Lower 2" NPT (f) SS Lower	3/4" NPT (f)
Y57xxx	5 HP (3.73 kW) 5.7 kVA 380–480 Vac 3 phase 50/60 Hz	220 cc	1.2 gpm (4.3 lpm)	5600 psi (386 bar, 38.6 mPa)	247 lb (112 kg)	1 1/4" NPT (m) CS Lower 2" NPT (f) SS Lower	3/4" NPT (f)
Y60xxx	5 HP (3.73 kW) 5.7 kVA 380–480 Vac 3 phase 50/60 Hz	220 cc	1.2 gpm (4.3 lpm)	5600 psi (386 bar, 38.6 mPa)	226 lb (103 kg)	1 1/4" NPT (m) CS Lower 2" NPT (f) SS Lower	3/4" NPT (f)
Y16xxx	2 HP (1.49 kW) 2.7 kVA 380–480 Vac 3 phase 50/60 Hz	290 cc	1.5 gpm (5.8 lpm)	1600 psi (110 bar, 11.0 mPa)	w/CS Lower 217 lb (98 kg) w/SS Lower 237 lb (108 kg)	1 1/4" NPT (m) CS Lower 2" NPT (f) SS Lower	3/4" NPT (f)
Y25xxx	3 HP (2.24 kW) 3.4 kVA 380–480 Vac 3 phase 50/60 Hz	290 cc	1.5 gpm (5.8 lpm)	2400 psi (165 bar, 16.5 mPa)	w/CS Lower 219 lb (99 kg) w/SS Lower 239 lb (108 kg)	1 1/4" NPT (m) CS Lower 2" NPT (f) SS Lower	3/4" NPT (f)
Y45xxx	5 HP (3.73 kW) 5.7 kVA 380–480 Vac 3 phase 50/60 Hz	290 cc	1.5 gpm (5.8 lpm)	4200 psi (290 bar, 29.0 mPa)	247 lb (112 kg)	1 1/4" NPT (m) CS Lower 2" NPT (f) SS Lower	3/4" NPT (f)
Y15xxxx	3 HP (2.24 kW) 3.4 kVA 380–480 Vac 3 phase 50/60 Hz	430 cc	1.2 gpm (4.3 lpm)	1600 psi (110 bar, 11.0 mPa)	w/CS Lower 248 lb (112 kg) w/SS Lower 248 lb (112 kg)	2" NPT (f)	3/4" NPT (f)

Technical Specifications

Models	Motor Rating	Lower Displacement	Flow Rate at 20 cpm	Maximum Fluid Working Pressure	Pump Weight	Fluid Inlet Connection	Fluid Outlet Connection
Y32xxx	5 HP (3.73 kW) 5.7 kVA 380–480 Vac 3 phase 50/60 Hz	430 cc	2.3 gpm (8.6 lpm)	2900 psi (200 bar, 20.0 mPa)	256 lb (116 kg)	2" NPT (f)	3/4" NPT (f)
Y12xxxx	3 HP (2.24 kW) 3.4 kVA 380–480 Vac 3 phase 50/60 Hz	580 cc	3.1 gpm (11.6 lpm)	1200 psi (83 bar, 8.3 mPa)	w/CS Lower 249 lb (113 kg) w/SS Lower 248 lb (112 kg)	2" NPT (f)	3/4" NPT (f)
Y23xxxx	5 HP (3.73 kW) 5.7 kVA 380–480 Vac 3 phase 50/60 Hz	580 cc	3.1 gpm (11.6 lpm)	2100 psi (145 bar, 14.5 mPa)	w/CS Lower 257 lb (117 kg) w/SS Lower 257 lb (117 kg)	2" NPT (f)	3/4" NPT (f)
Y06xxxx	3 HP (2.24 kW) 3.4 kVA 380–480 Vac 3 phase 50/60 Hz	1000 cc	5.8 gpm (22 lpm)	650 psi (45 bar, 4.5 mPa)	w/CS Lower 226 lb (103 kg) w/SS Lower 226 lb (103 kg)	2" NPT (f)	3/4" NPT (f)
Y10xxxx	5 HP (3.73 kW) 5.7 kVA 380–480 Vac 3 phase 50/60 Hz	1000 cc	5.8 gpm (22 lpm)	1100 psi (76 bar, 7.6 mPa)	w/CS Lower xxx lb (xxx kg) w/SS Lower 234 lb (106 kg)	2" NPT (f)	3/4" NPT (f)
Recommended Maximum Continuous Cycle Rate			20 cpm				
Sound Data†			Less than 80 dB(A)				
Ambient Temperature Range			32–104°F (0–40°C)				
Floor stand weight❖			65 lb (29.5 kg)				
Wall mount weight ❖			20 lb (9.1 kg)				
Oil capacity			2.0 quarts (1.9 liters)				
Oil specification			Graco Part Number 20A933 ISO 460 silicone-free high-pressure synthetic gear oil				

Models	Motor Rating	Lower Displacement	Flow Rate at 20 cpm	Maximum Fluid Working Pressure	Pump Weight	Fluid Inlet Connection	Fluid Outlet Connection
Wetted Parts			See lower manual. Find your lower part number in the <b>Pump Matrix</b> , page 18.				

❖ Add to the pump weight to determine total weight.

† Sound data measured 1 meter from a 5 HP motor with a 20 cpm flow rate.

## California Proposition 65

### CALIFORNIA RESIDENTS

 **WARNING:** Cancer and reproductive harm. – [www.P65warnings.ca.gov](http://www.P65warnings.ca.gov).

# Graco Standard Warranty

Graco warrants all equipment referenced in this document which is manufactured by Graco and bearing its name to be free from defects in material and workmanship on the date of sale to the original purchaser for use. With the exception of any special, extended, or limited warranty published by Graco, Graco will, for a period of twelve months from the date of sale, repair or replace any part of the equipment determined by Graco to be defective. This warranty applies only when the equipment is installed, operated and maintained in accordance with Graco's written recommendations.

This warranty does not cover, and Graco shall not be liable for general wear and tear, or any malfunction, damage or wear caused by faulty installation, misapplication, abrasion, corrosion, inadequate or improper maintenance, negligence, accident, tampering, or substitution of non-Graco component parts. Nor shall Graco be liable for malfunction, damage or wear caused by the incompatibility of Graco equipment with structures, accessories, equipment or materials not supplied by Graco, or the improper design, manufacture, installation, operation or maintenance of structures, accessories, equipment or materials not supplied by Graco.

This warranty is conditioned upon the prepaid return of the equipment claimed to be defective to an authorized Graco distributor for verification of the claimed defect. If the claimed defect is verified, Graco will repair or replace free of charge any defective parts. The equipment will be returned to the original purchaser transportation prepaid. If inspection of the equipment does not disclose any defect in material or workmanship, repairs will be made at a reasonable charge, which charges may include the costs of parts, labor, and transportation.

**THIS WARRANTY IS EXCLUSIVE, AND IS IN LIEU OF ANY OTHER WARRANTIES, EXPRESS OR IMPLIED, INCLUDING BUT NOT LIMITED TO WARRANTY OF MERCHANTABILITY OR WARRANTY OF FITNESS FOR A PARTICULAR PURPOSE.**

Graco's sole obligation and buyer's sole remedy for any breach of warranty shall be as set forth above. The buyer agrees that no other remedy (including, but not limited to, incidental or consequential damages for lost profits, lost sales, injury to person or property, or any other incidental or consequential loss) shall be available. Any action for breach of warranty must be brought within two (2) years of the date of sale.

**GRACO MAKES NO WARRANTY, AND DISCLAIMS ALL IMPLIED WARRANTIES OF MERCHANTABILITY AND FITNESS FOR A PARTICULAR PURPOSE, IN CONNECTION WITH ACCESSORIES, EQUIPMENT, MATERIALS OR COMPONENTS SOLD BUT NOT MANUFACTURED BY GRACO.** These items sold, but not manufactured by Graco (such as electric motors, switches, hose, etc.), are subject to the warranty, if any, of their manufacturer. Graco will provide purchaser with reasonable assistance in making any claim for breach of these warranties.

In no event will Graco be liable for indirect, incidental, special or consequential damages resulting from Graco supplying equipment hereunder, or the furnishing, performance, or use of any products or other goods sold hereto, whether due to a breach of contract, breach of warranty, the negligence of Graco, or otherwise.

## **FOR GRACO CANADA CUSTOMERS**

The Parties acknowledge that they have required that the present document, as well as all documents, notices and legal proceedings entered into, given or instituted pursuant hereto or relating directly or indirectly hereto, be drawn up in English. Les parties reconnaissent avoir convenu que la rédaction du présente document sera en Anglais, ainsi que tous documents, avis et procédures judiciaires exécutés, donnés ou intentés, à la suite de ou en rapport, directement ou indirectement, avec les procédures concernées.

# Graco Information

For the latest information about Graco products, visit [www.graco.com](http://www.graco.com).

For patent information, see [www.graco.com/patents](http://www.graco.com/patents).

**TO PLACE AN ORDER**, contact your Graco distributor or call to identify the nearest distributor.

**Phone:** 612-623-6921 **or Toll Free:** 1-800-328-0211, **Fax:** 612-378-3505

*All written and visual data contained in this document reflects the latest product information available at the time of publication. Graco reserves the right to make changes at any time without notice.*

Original instructions. This manual contains English. MM 3A7826

**Graco Headquarters:** Minneapolis

**International Offices:** Belgium, China, Japan, Korea

**GRACO INC. AND SUBSIDIARIES • P.O. BOX 1441 • MINNEAPOLIS MN 55440-1441 • USA**  
**Copyright 2022, Graco Inc. All Graco manufacturing locations are registered to ISO 9001.**

[www.graco.com](http://www.graco.com)  
Revision B, December 2022