

Junction Box for XP™ and XM™ Proportioners

3A7523E

EN

For distributing power to the heaters and heated hose of XM™ and XP™ Proportioners.

For professional use only.

See page 3 for model information and agency approvals.



Important Safety Instructions

Read all warnings and instructions in this manual and in your Proportioner and heated hose manuals before using the equipment. Save these instructions.

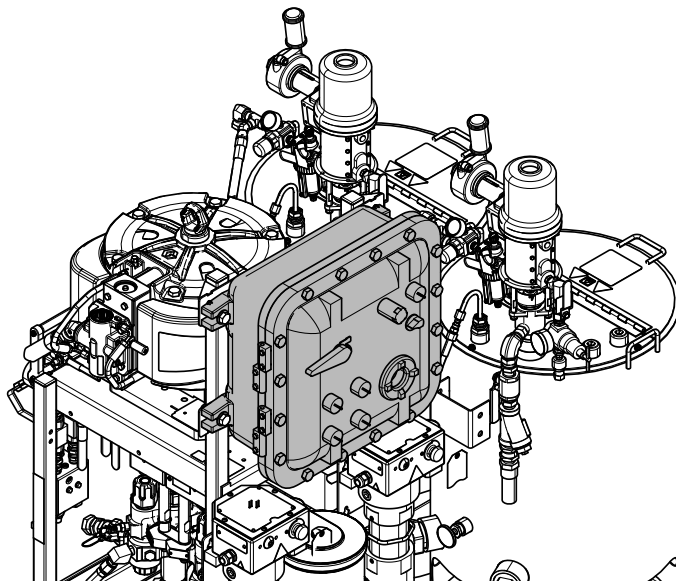

**Hazardous Locations
(XP Skid Shown)**

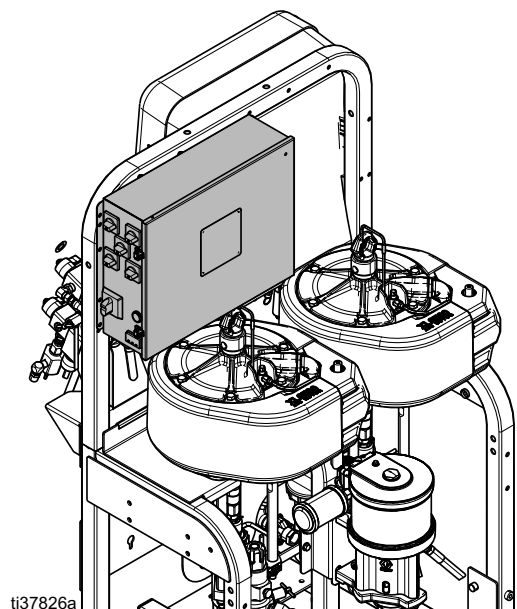

**Non-Hazardous Locations
(XM Shown)**

Contents



Related Manuals	2	Water Heated Hose - 240V Hazardous Locations . . .	32
Models and Approvals	3	Water Heated Hose - 480V Non-Hazardous Locations	33
Non-Hazardous Locations	3	Water Heated Hose - 480V Hazardous Locations . . .	34
Hazardous Locations	3	Electric Heated Hose - 240V Non-Hazardous Locations	
Warnings	4	Series A	35
Component Identification	6	Electric Heated Hose - 240V Non-Hazardous Locations	
Junction Box	6	Series B	36
Installation	7	Electric Heated Hose - 240V Hazardous Locations Series	
Hazardous Locations	7	A	37
Non-Hazardous Locations	11	Electric Heated Hose - 240V Hazardous Locations Series	
Connect Power	13	B	38
Wiring Diagrams	14	Electric Heated Hose - 480V Non-Hazardous Locations	
Power Wiring Diagram	14	39	
Heater Wiring Diagrams	15	Electric Heated Hose - 480V Hazardous Locations . .	40
Parts	21	Recycling and Disposal	41
Junction Boxes	21	End of Product Life	41
Wiring Schematics	31	Graco Standard Warranty	43
Water Heated Hose - 240V Non-Hazardous Locations	31		

Related Manuals

Part	Description
3A2954	Viscon [®] HF Heater - Operation, Repair and Parts Manual
309524	Viscon [®] HP - Operation, Repair and Parts Manual
3A6283	XP _s -hf [™] Proportioner - Operation Manual
312359	XM [™] Proportioner - Operation Manual
3A7524	Xtreme-Wrap [™] Electric Heated Hose - Operation Manual
3A7682	Electric Heated Hose Temperature Controller - Operation Manual
3A5314	Hose and Hopper Heat Circulation XP and XP-hf Retrofit Kit - Instruction Manual
3A6110	Double Wall Hopper - Instruction Manual
3A5313	Water Heated Hose - Instruction Manual

Models and Approvals

Non-Hazardous Locations

Model	Series	Description	Volts AC	Type	Hz	Maximum Amps	Approvals
26C580	A	Junction Box, 240V	200-240	1 Phase	50/60	87	  Intertek 5024314 Conforms to UL STD 508A Certified to CSA STDS C22.2 No. 286
			200-240 Delta	3 Phase	50/60	78	
			350-415 WYE	3 Phase+N	50/60	46	
26C582	A	Junction Box, 480V	480	3 Phase	60	28	
26C899	B	Junction Box, 240 V, with Electric Hose Temperature Controller	200-240	1 Phase	50/60	87	
			220-240 Delta	3 Phase	50/60	78	
			350-415 WYE	3 Phase+N	50/60	46	
26C904	A	Junction Box, 480V, with Electric Hose Temperature Controller	480	3 Phase	60	28	



Hazardous Locations





Model	Series	Description	Volts AC	Type	Hz	Maximum Amps	Approvals
		Explosion Proof Electrical Enclosure*					 Class I, Division 1, Groups B, C, & D UL 1203/CSA C22.2 No. 25 & 30
26C581	A	Junction Box, 240V	200-240	1 Phase	50/60	87	Designed to standards: UL 60079-0 UL 60079-25
			200-240 Delta	3 Phase	50/60	78	
			350-415 WYE	3 Phase+N	50/60	46	
26C583	A	Junction Box, 480V	480	3 Phase	60	28	
26C905	B	Junction Box, 240 V, with Electric Hose Temperature Controller	200-240	1 Phase	50/60	87	
			220-240 Delta	3 Phase	50/60	78	
			350-415 WYE	3 Phase+N	50/60	46	
26C906	A	Junction Box, 480V, with Electric Hose Temperature Controller	480	3 Phase	60	28	

* An explosion-proof enclosure that is rated for Class I, Division 1 is used in the junction box models listed.



Warnings

The following warnings are for the setup, use, grounding, maintenance, and repair of this equipment. The exclamation point symbol alerts you to a general warning and the hazard symbols refer to procedure-specific risks. When these symbols appear in the body of this manual or on warning labels, refer back to these Warnings. Product-specific hazard symbols and warnings not covered in this section may appear throughout the body of this manual where applicable.

 <h2 style="margin: 0;">DANGER</h2>	
 	<p>SEVERE ELECTRIC SHOCK HAZARD</p> <p>This equipment can be powered by more than 240 V. Contact with this voltage will cause death or serious injury.</p> <ul style="list-style-type: none"> • Turn off and disconnect power at main switch before disconnecting any cables and before servicing equipment. • This equipment must be grounded. Connect only to grounded power source. • All electrical wiring must be done by a qualified electrician and comply with all local codes and regulations.

 <h2 style="margin: 0;">WARNING</h2>	
   	<p>FIRE AND EXPLOSION HAZARD</p> <p>Flammable fumes, such as solvent and paint fumes, in work area can ignite or explode. Paint or solvent flowing through the equipment can cause static sparking. To help prevent fire and explosion:</p> <ul style="list-style-type: none"> • Use equipment only in well-ventilated area. • Eliminate all ignition sources; such as pilot lights, cigarettes, portable electric lamps, and plastic drop cloths (potential static sparking). • Ground all equipment in the work area. See Grounding instructions. • Never spray or flush solvent at high pressure. • Keep work area free of debris, including solvent, rags and gasoline. • Do not plug or unplug power cords, or turn power or light switches on or off when flammable fumes are present. • Use only grounded hoses. • Hold gun firmly to side of grounded pail when triggering into pail. Do not use pail liners unless they are anti-static or conductive. • Stop operation immediately if static sparking occurs or you feel a shock. Do not use equipment until you identify and correct the problem. • Keep a working fire extinguisher in the work area.

WARNING

 	<p>EQUIPMENT MISUSE HAZARD</p> <p>Misuse can cause death or serious injury.</p> <ul style="list-style-type: none">• Do not operate the unit when fatigued or under the influence of drugs or alcohol.• Do not exceed the maximum working pressure or temperature rating of the lowest rated system component. See Technical Specifications in all equipment manuals.• Use fluids and solvents that are compatible with equipment wetted parts. See Technical Specifications in all equipment manuals. Read fluid and solvent manufacturer's warnings. For complete information about your material, request Safety Data Sheets (SDSs) from distributor or retailer.• Turn off all equipment and follow the Pressure Relief Procedure when equipment is not in use.• Check equipment daily. Repair or replace worn or damaged parts immediately with genuine manufacturer's replacement parts only.• Do not alter or modify equipment. Alterations or modifications may void agency approvals and create safety hazards.• Make sure all equipment is rated and approved for the environment in which you are using it.• Use equipment only for its intended purpose. Call your distributor for information.• Route hoses and cables away from traffic areas, sharp edges, moving parts, and hot surfaces.• Do not kink or over bend hoses or use hoses to pull equipment.• Keep children and animals away from work area.• Comply with all applicable safety regulations.
	<p>PERSONAL PROTECTIVE EQUIPMENT</p> <p>Wear appropriate protective equipment when in the work area to help prevent serious injury, including eye injury, hearing loss, inhalation of toxic fumes, and burns. Protective equipment includes but is not limited to:</p> <ul style="list-style-type: none">• Protective eyewear, and hearing protection.• Respirators, protective clothing, and gloves as recommended by the fluid and solvent manufacturer.

Component Identification

Junction Box

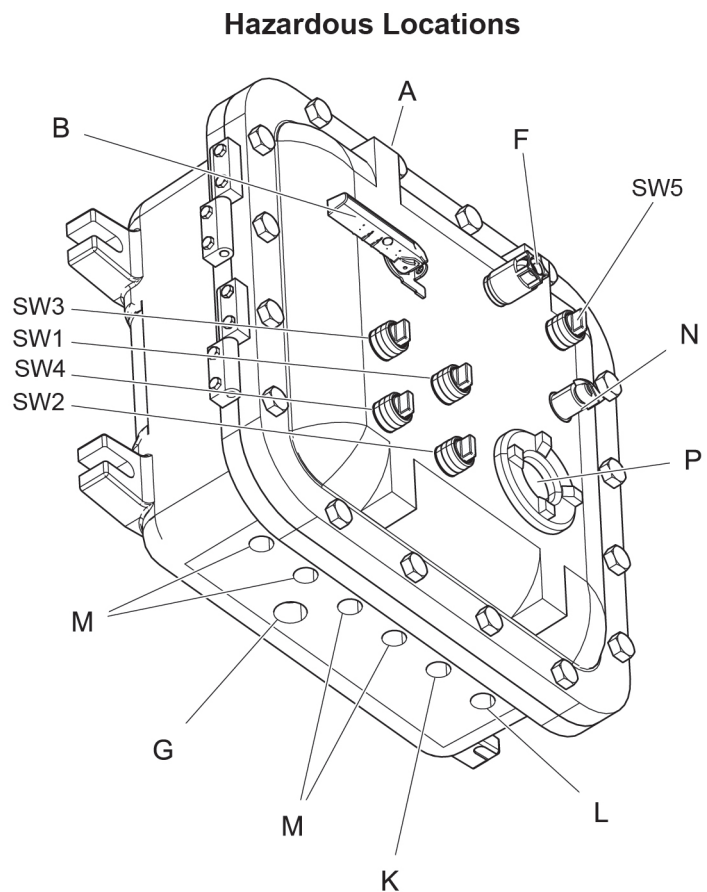
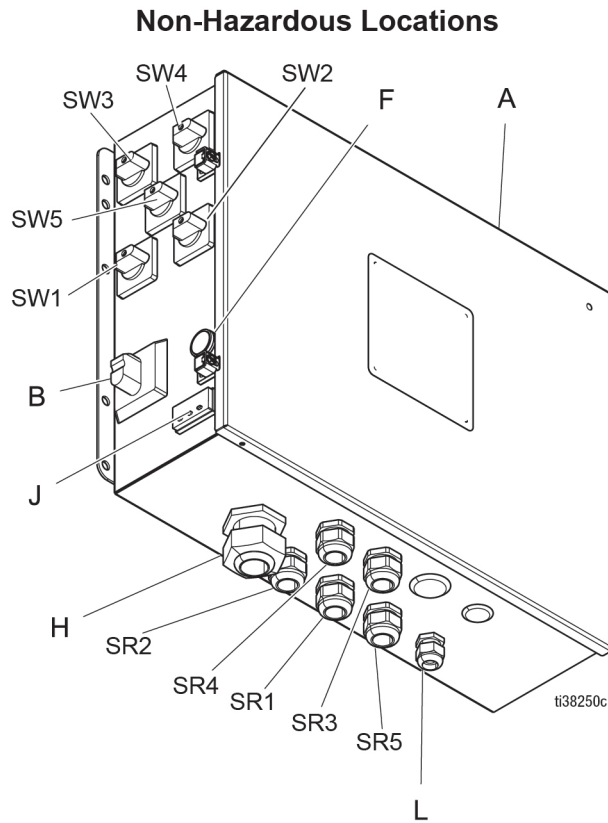

Ref.	Description
A	Electrical Enclosure
B	Main Power Switch
F	Power Indicator Light
G	Main Power Entry Point
H	Main Power Strain Relief (Non-hazardous locations only)
J	Electric Heated Hose Temperature Control / Display (Non-hazardous locations only)
K	Hose Heater Harness Entry Point
L	Thermocouple Sensor Entry Point
M	Fluid Heater and Hopper Heater Harness Entry Point

Ref.	Description
N	Electric Heated Hose Temperature Control (Hazardous locations only)
P	Temperature Display (Hazardous locations only)
SW1	A Hopper Heater Switch
SW2	B Hopper Heater Switch
SW3	A Primary Heater Switch
SW4	B Primary Heater Switch
SW5	Hose Heater Switch
SR1	A Hopper Heater Harness Strain Relief
SR2	B Hopper Heater Harness Strain Relief
SR3	A Primary Heater Harness Strain Relief
SR4	B Primary Heater Harness Strain Relief
SR5	Hose Heater Harness Strain Relief

Installation

Hazardous Locations



If your sprayer is intended for use in a hazardous location, ensure that the base model, all accessories, all kits, and all wiring meet local codes and regulations for hazardous locations. A qualified electrician must connect all wiring. Improperly connected equipment may result in fire, explosion, or electric shock.

When explosion-proof heaters are used, ensure wiring, wiring connections, switches, and electrical distribution panel all meet flame-proof (explosion-proof) requirements.

Refer to your Viscon HF heater manual for electrical connection instructions and guidelines in hazardous locations.

Refer to your Viscon HP heater manual for electrical connection instructions and guidelines in hazardous locations.

Hazardous Location Cabling and Conduit Requirements

All electrical wiring in the hazardous location must be encased in Class I, Division 1, Groups B, C, and D approved explosion-proof conduit. Follow all local codes and regulations.

All cables must be rated to 70 °C (158 °F).

Connect Primary Heater Harness

All wiring, wiring connections, switches, and distribution panel must meet flame-proof (explosion-proof) requirements.

1. Follow local code and regulations when routing the "A" primary heater harness through heater harness entry point (M).
2. Attach the ground wire securely to the ground bar (GB). See **Heater Wiring Diagrams** on pages 18 - 20.
3. Attach two wires to heater switch (SW3). See **Heater Wiring Diagrams** on pages 18 - 20.
4. Follow local code and regulations when routing the "B" primary heater harness through heater harness entry point (M).
5. Attach the ground wire securely to the ground bar (GB). See **Heater Wiring Diagrams** on pages 18 - 20.
6. Attach two wires to heater switch (SW4). See **Heater Wiring Diagrams** on pages 18 - 20.
7. Follow local codes and regulations for sealing the fluid heater harness entering the enclosure.

NOTE: Refer to your Viscon HF or HP heater manual for electrical connection instructions and guidelines in hazardous locations.

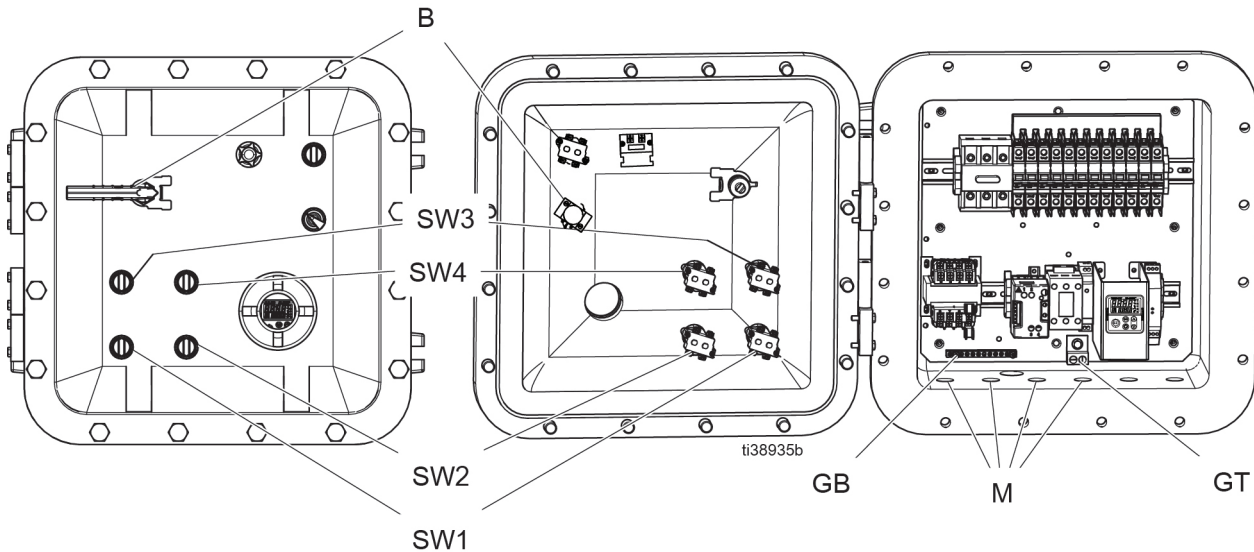

Connect Hose Heater Harness

All wiring, wiring connections, switches, and distribution panel must meet flame-proof (explosion-proof) requirements. See **Hazardous Location Cabling and Conduit Requirements** on page 7.

1. Follow local code and regulations when routing the hose heater harness through the hose heater entry point (K).
2. Attach the ground wire securely to the ground bar (GB). See **Heater Wiring Diagrams** on pages 18.
3. Attach the two cable wires to heater switch (SW5). See **Heater Wiring Diagrams** on pages 18.
4. Follow local code and regulations for sealing the fluid heater harness entering the enclosure.

NOTE: Refer to your Viscon HP heater manual for electrical connection instructions and guidelines in hazardous locations.

Connect Electric Heated Hose

See your Xtreme-Wrap electric heated hose controller manual for electrical connection instructions.

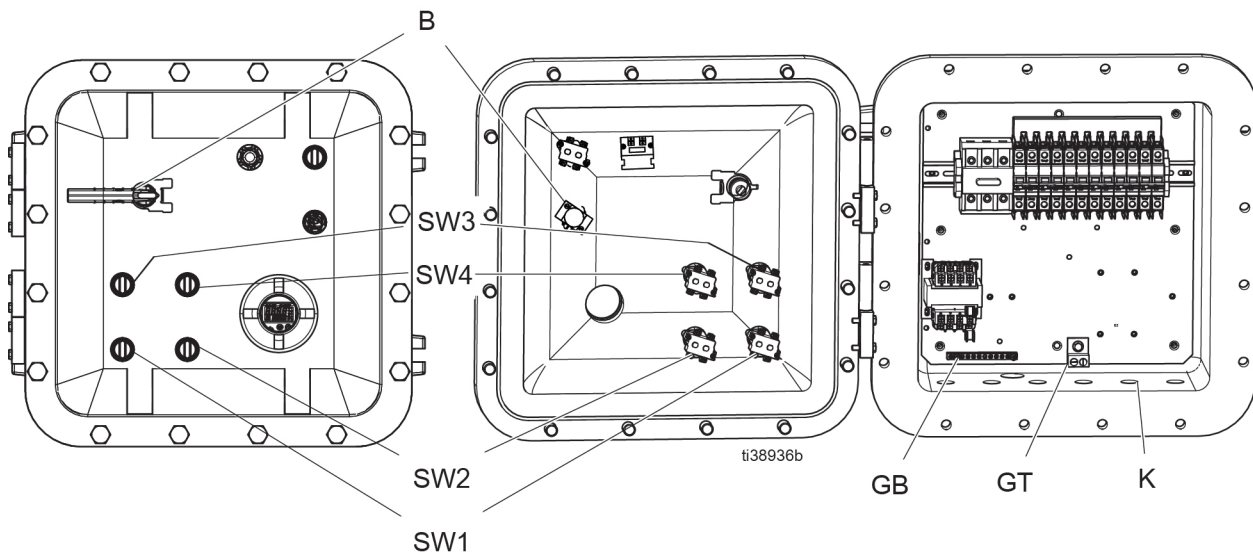

Connect Hopper Heater Harness

All wiring, wiring connections, switches, and distribution panel must meet flame-proof (explosion-proof) requirements. See **Hazardous Location Cabling and Conduit Requirements** on page 7.

1. Follow local code and regulations when routing the "A" hopper heater harness through fluid heater entry point (M).
2. Attach the ground wire securely to the ground bar (GB). See **Heater Wiring Diagrams** on pages 18 - 20.
3. Attach the two cable wires to heater switch (SW5). See **Heater Wiring Diagrams** on pages 18 - 20.
4. Follow local code and regulations when routing the "B" hopper heater harness through fluid heater entry point (M).
5. Attach the ground wire securely to the ground bar (GB). See **Heater Wiring Diagrams** on pages 18 - 20.
6. Attach the two cable wires to (SW2). See **Heater Wiring Diagrams** on pages 18 - 20.
7. Follow local code and regulations for sealing the fluid heater harness entering the enclosure (M).

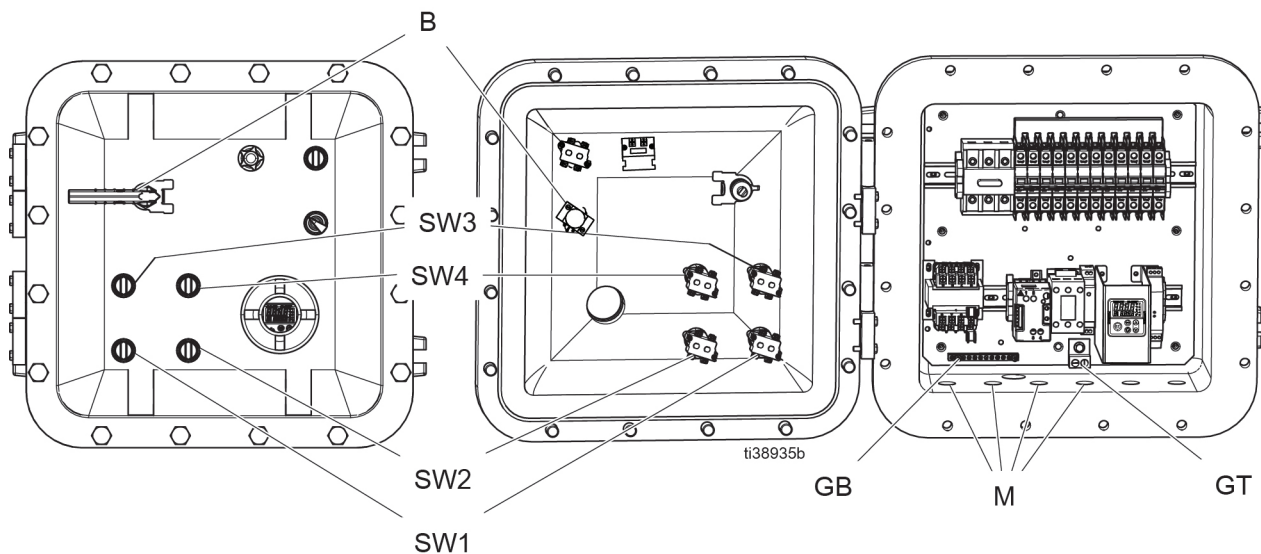

Non-Hazardous Locations

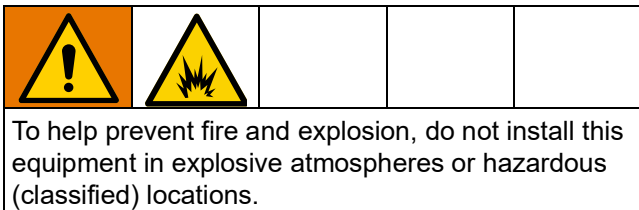

Connect Primary Heater Harness

1. Route the "A" primary heater harness through the cord strain relief (SR3).
2. Attach the ground wire securely to the ground bar (GB). See **Heater Wiring Diagrams** on pages 15 - 17.

3. Attach the two wires to heater switch (SW3). See **Heater Wiring Diagrams** on pages 15 - 17.

NOTE: The switch body can be easily removed from the knob by rotating the red lock arm upward to unlock.

4. Route the "B" primary heater harness through the cord strain relief (SR4).

5. Attach the ground wire securely to the ground bar (GB). See **Heater Wiring Diagrams** on pages 15 - 17.

6. Attach the two wires to heater switch (SW4). See **Heater Wiring Diagrams** on pages 15 - 17.

7. Tighten strain reliefs (SR3 and SR4).

NOTE: See your heater instruction manual for installation requirements and operation.

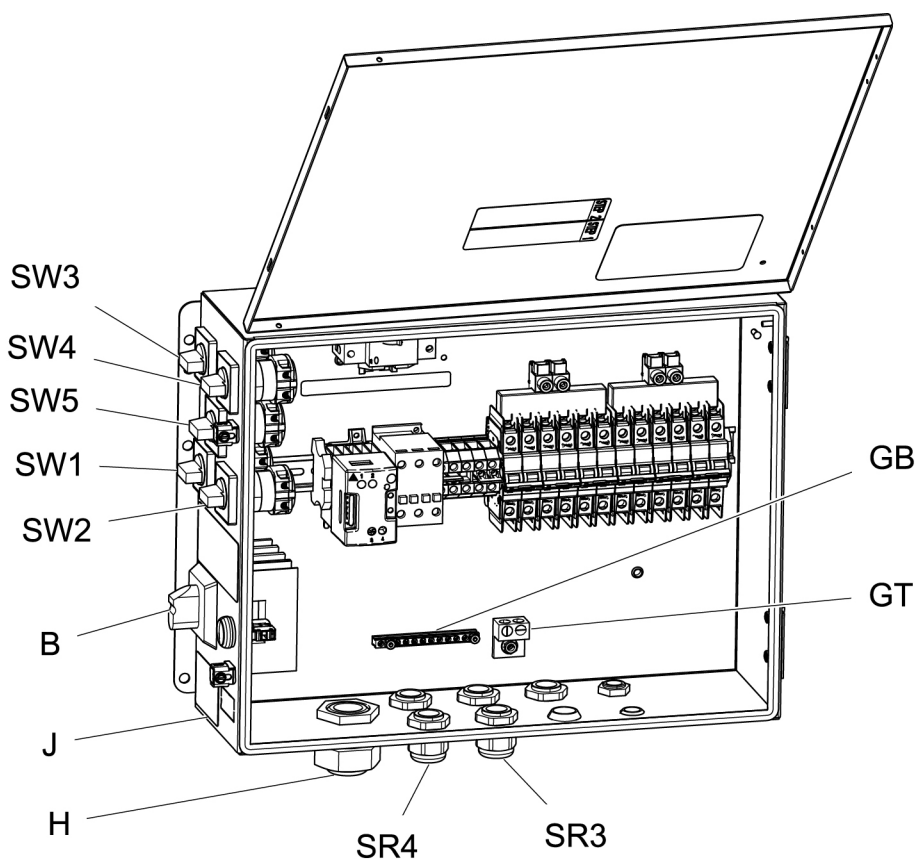

Model 26C899 shown

Connect Water Heated Hose Harness

1. Route the hose heater harness through the cord strain relief (SR5).
2. Attach the ground wire securely to the ground bar (GB). See **Heater Wiring Diagrams** on page 17.
3. Attach the two cable wires to heater switch (SW5). See **Heater Wiring Diagrams** on page 17.

NOTE: The switch body can be easily removed from the knob by rotating the red lock arm upward to unlock.

4. Tighten strain relief (SR5).

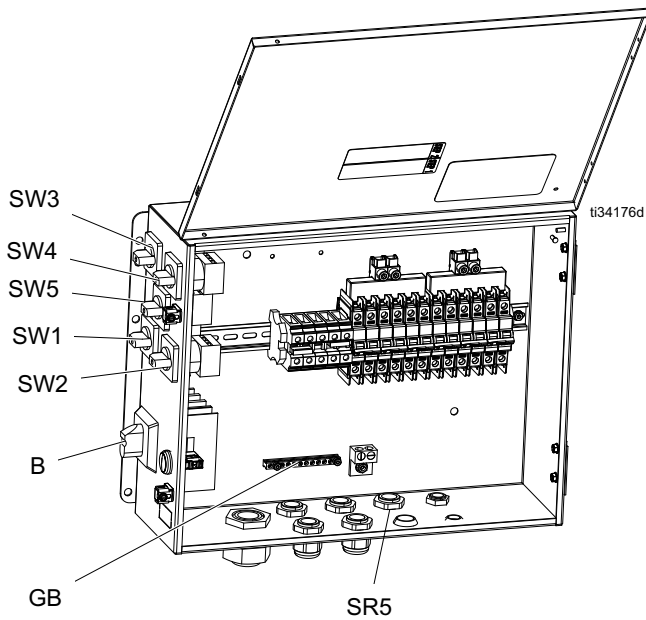

Model 26C580 shown

Connect Electric Heated Hose

See your Xtreme-Wrap™ electric heated hose controller manual for electrical connection instructions.

Connect Hopper Heater Harness

1. Route the “A” hopper heater harness through the cord strain relief (SR1).
2. Attach the ground wire securely to the ground bar (GB). See **Heater Wiring Diagrams** on page 15 - 17.
3. Attach the two cable wires to (SW1). See **Heater Wiring Diagrams** on page 15 - 17.

NOTE: The switch body can be easily removed from the knob by rotating the red lock arm upward to unlock.

4. Route the “B” hopper heater harness through (SR2).
5. Attach the ground wire securely to the ground bar (GB). See **Heater Wiring Diagrams** on page 15 - 17.
6. Attach the two cable wires to (SW2). See **Heater Wiring Diagrams** on page 15 - 17.
7. Tighten strain reliefs (SR1, SR2).

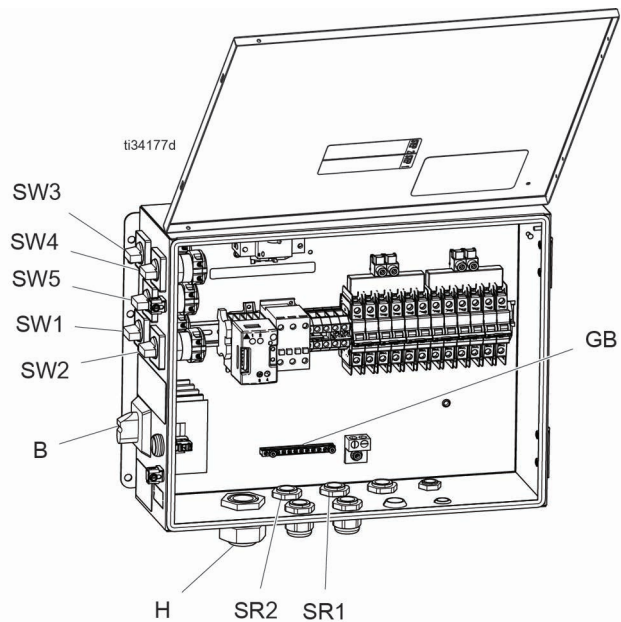

Model 26C899 shown

Connect Power

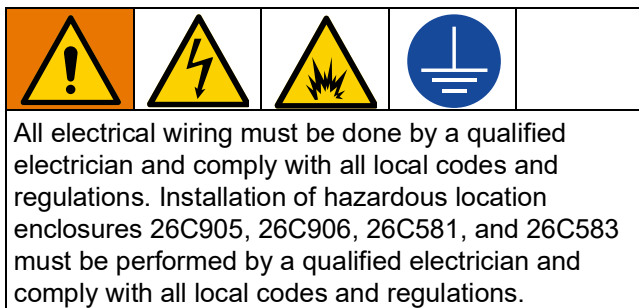

NOTE: Follow the intended entry locations shown in **Component Identification** on page 6.

1. Turn the main power switch (B) OFF.
2. Open the electrical enclosure door.
3. **Non-Hazardous Locations only:** Route the power cord through the strain relief (H) into the electrical enclosure (A), see page 6.

Hazardous Locations only: Follow local codes and regulations for routing the power cord through the main power entry point (G) electrical enclosure (A), see page 6.

4. Connect the ground wire to ground terminal (GT).
5. Connect the power cord to the disconnect as shown in the **Wiring Diagrams** on page 14. Tighten conductors to 55 in-lb (6.2 N•m). Gently pull on all connections to verify that they are properly secured.
6. **Non-Hazardous Locations only:** Tighten strain relief (H).
Hazardous Locations only: Follow local codes and regulations for sealing the power cable entering into the enclosure.
7. Install the supplied terminal jumpers in the positions shown in the **Wiring Diagrams** on page 14 for the power source used.
8. Verify that all items are connected properly as shown in the **Wiring Diagrams** on page 14, then close the electrical enclosure door.

NOTE: The machine is shipped with jumpers in the 380 V (WYE) position.

NOTE: Terminal jumpers are only applicable with 230V-380V.

Wiring Diagrams

Power Wiring Diagram

NON-HAZARDOUS LOCATIONS

HAZARDOUS LOCATIONS

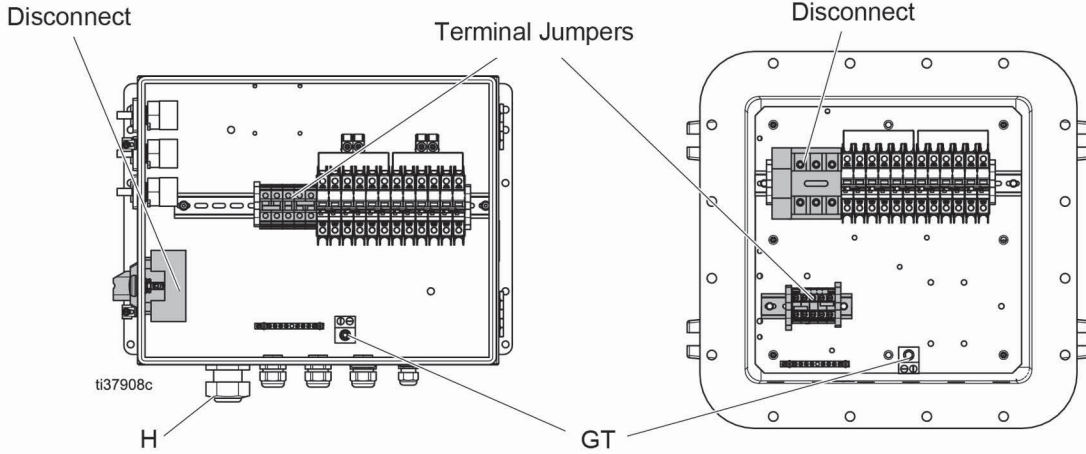

**230 Vac
1-Phase**

**230 Vac
3-Phase Delta**

**380 Vac
3-Phase Wye**

**480 Vac
3-Phase Delta**

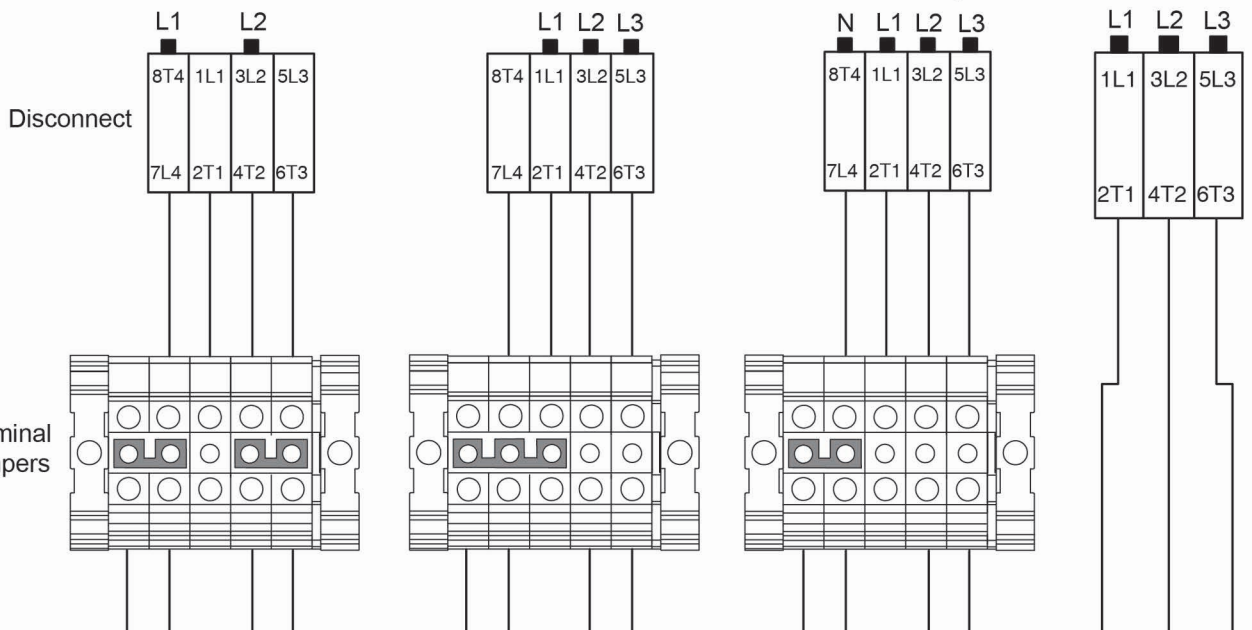

Heater Wiring Diagrams

Non-Hazardous Location 240V Electric Heated Hose

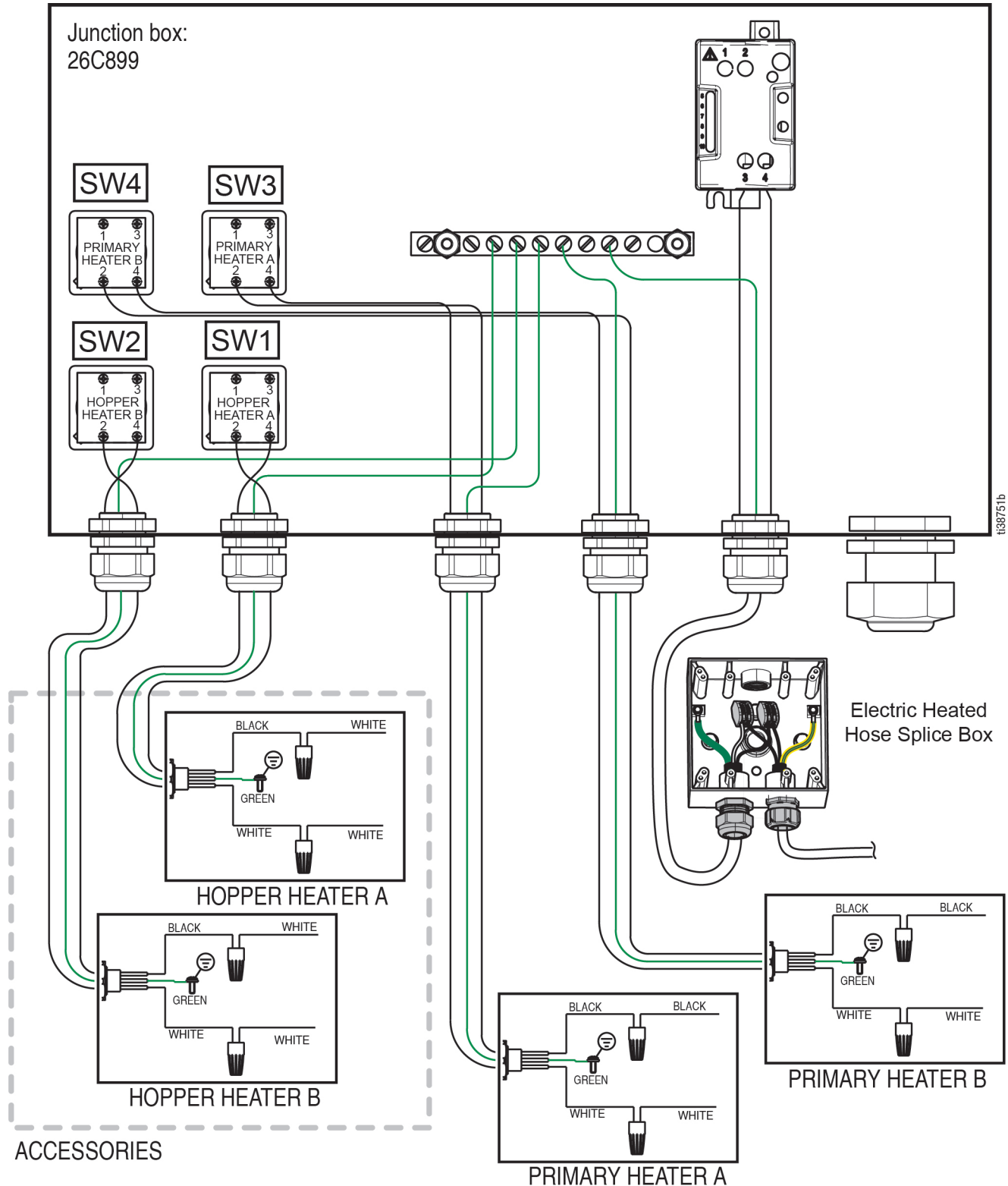

Non-Hazardous Location 480V Electric Heated Hose

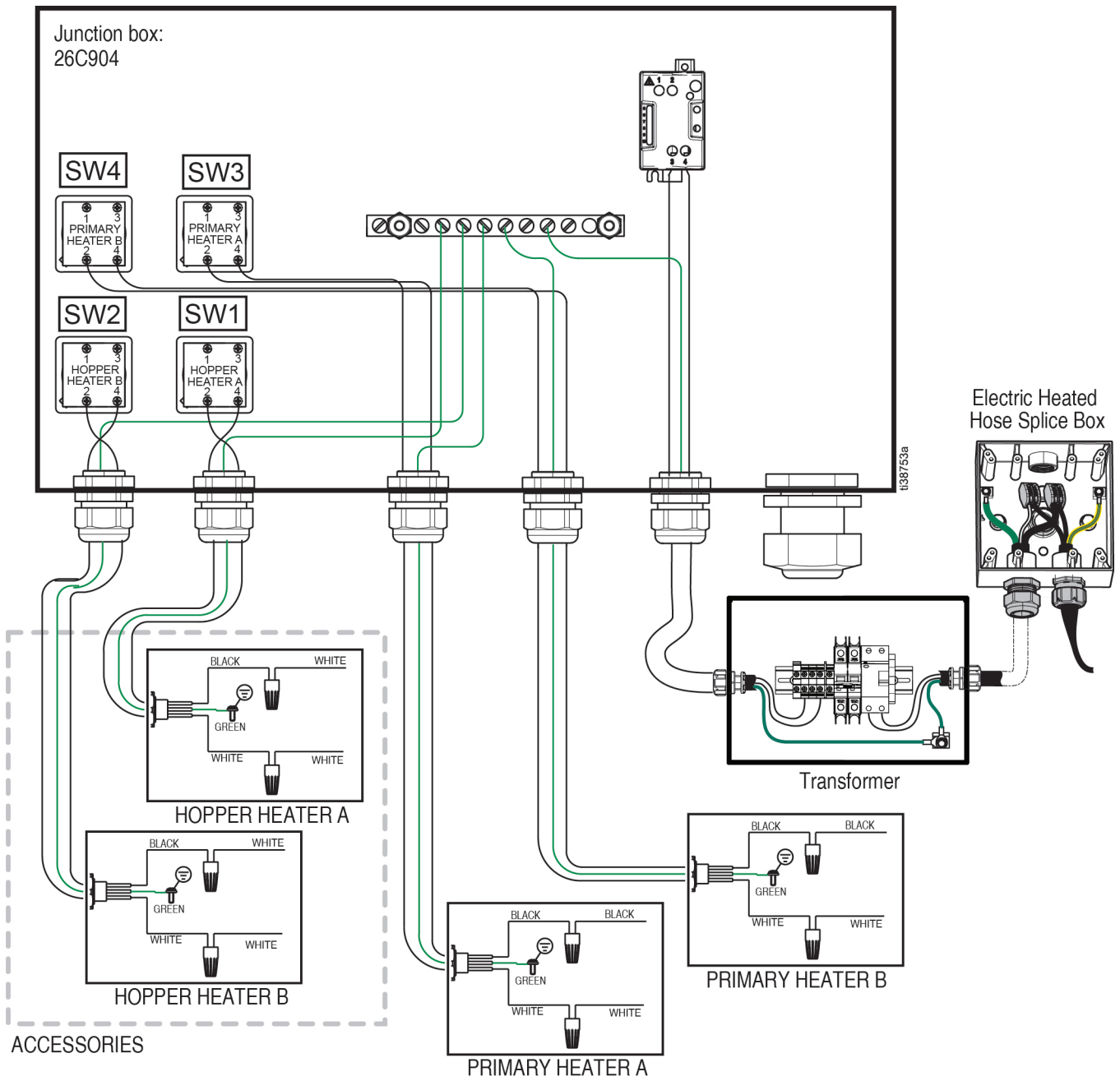

Non-Hazardous Location 240V and 480V Water Heated Hose

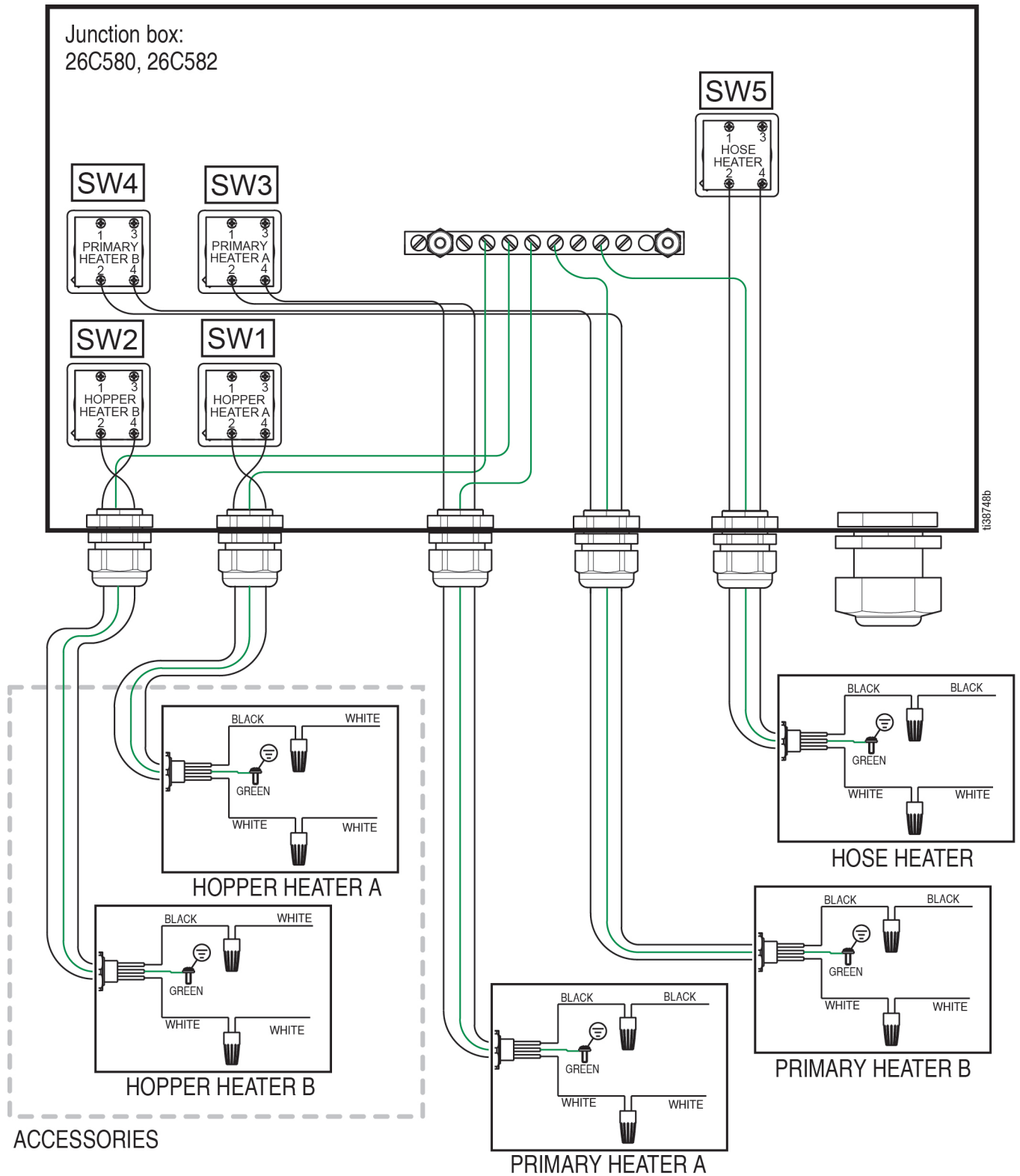

Hazardous Location 240V and 480V Water Heated Hose

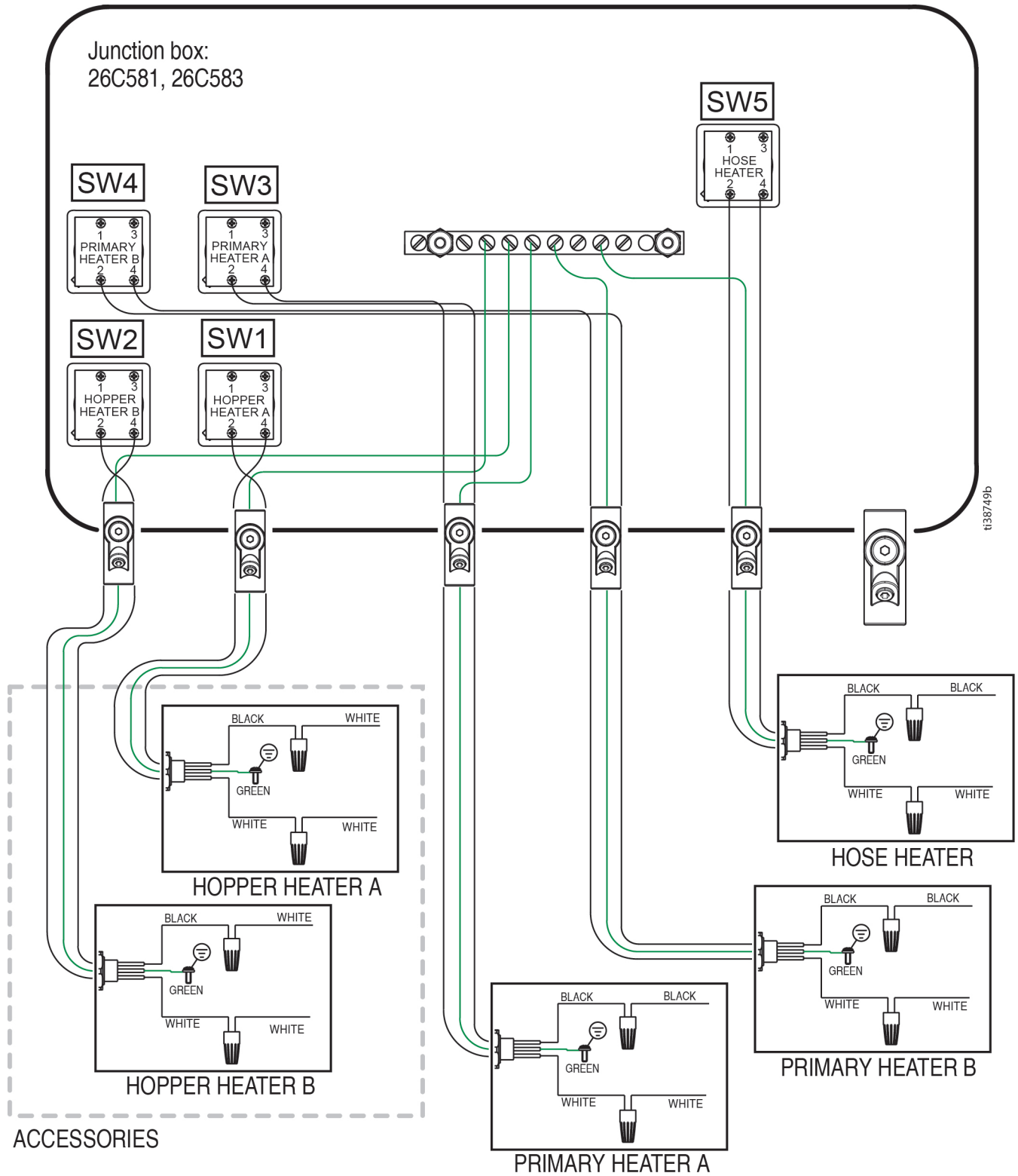

Hazardous Location 240V Electric Heated Hose

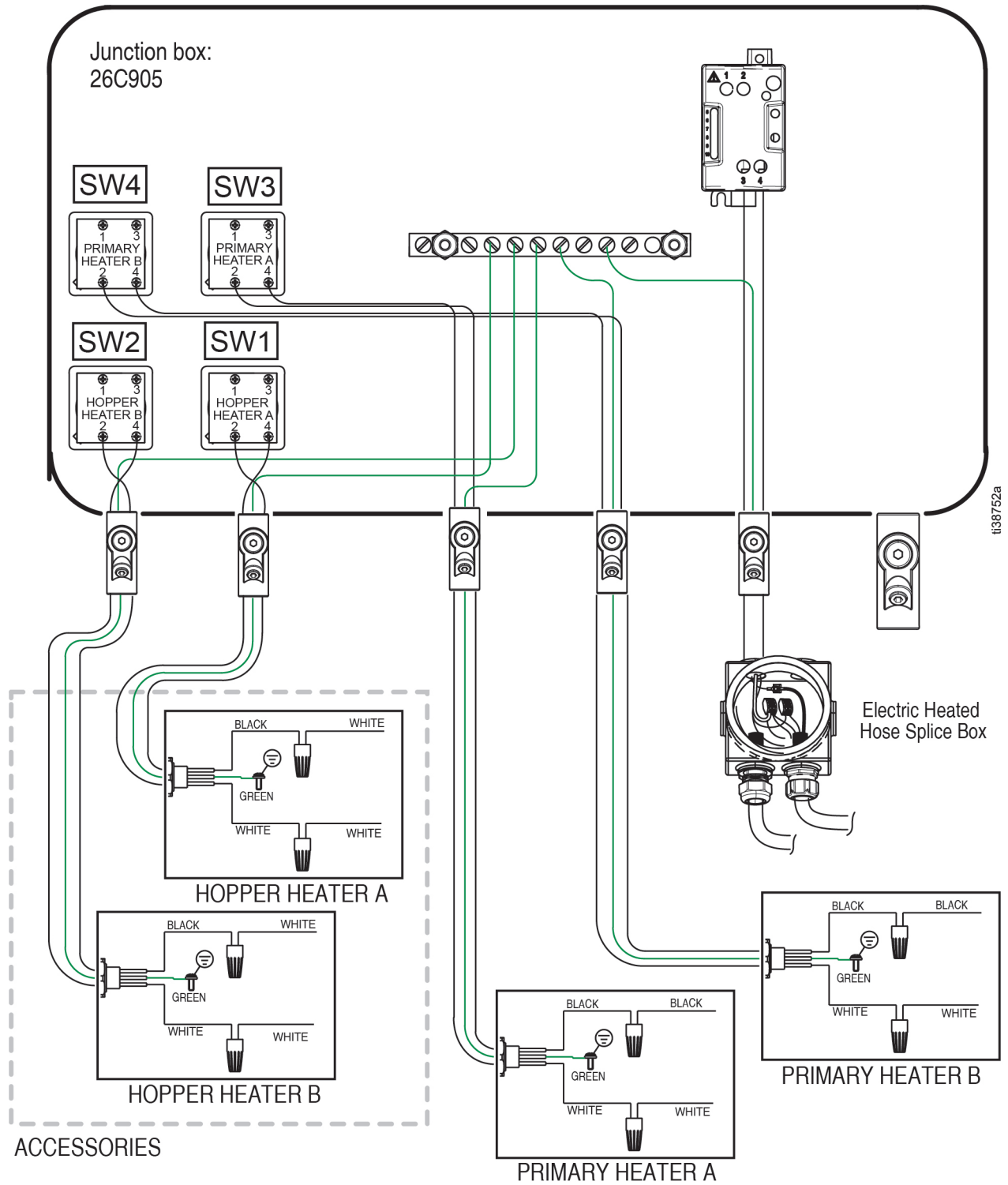

Hazardous Location 480V Electric Heated Hose

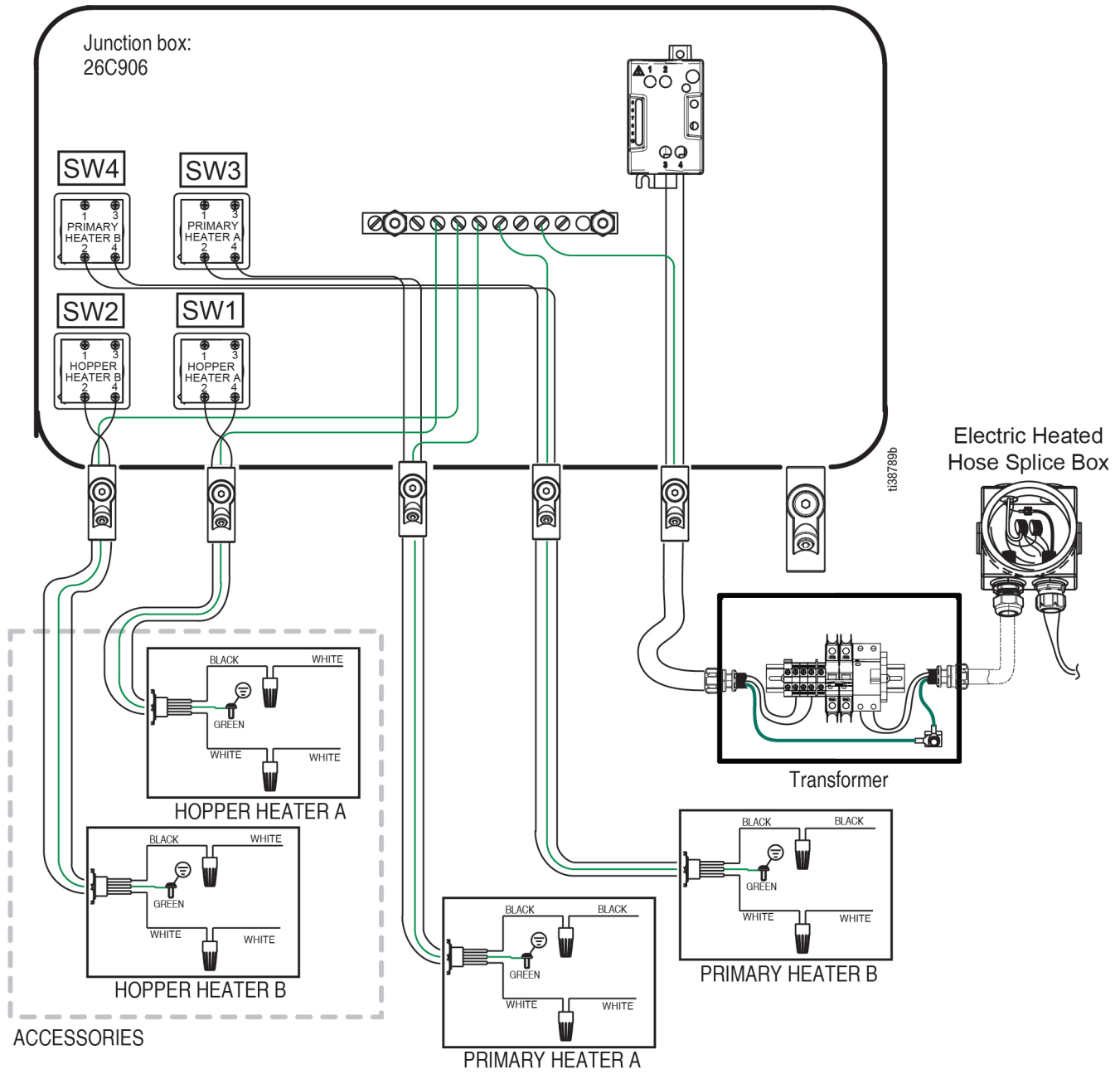

Parts

Junction Boxes

240V Non-Hazardous Locations Parts (26C899 shown)

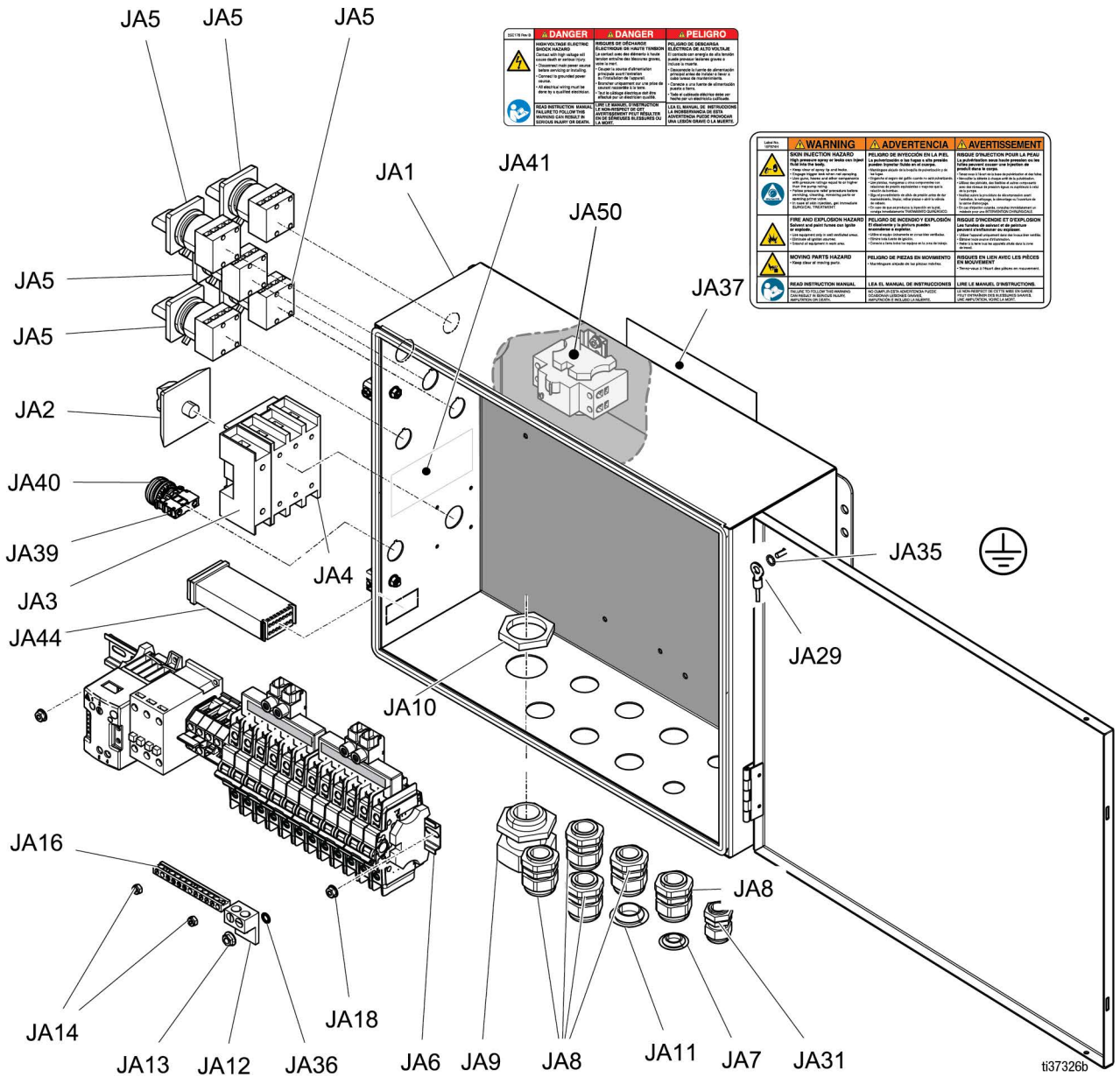

240V Non-Hazardous Locations Parts List

Ref.	Part	Description	Qty.	
			26C899	26C580
JA1	18A497	ENCLOSURE, electrical, XP/XM	1	1
JA2	123967	KNOB, operator disconnect	1	1
JA3	123968	SWITCH, disconnect, ph exp 100 amp	1	1
JA4	123969	SWITCH, disconnect, 100A (E-30/)	1	1
JA5	15U423	SWITCH, 2P, 25A	5	5
JA6	26C720	MODULE, din rail, ASM, 240V, breaker (see page 23)		1
	26C911*	MODULE, din rail, ASM, 240V, with controller (see page 23)	1	
JA7	15U543	PLUG, hole, 7/8 in.	1	1
JA8	116171	BUSHING, strain relief	5	5
JA9	120858	BUSHING, strain relief, m40 thread	1	1
JA10	120859	NUT, strain relief, m40 thread	1	1
JA11	15U544	PLUG, hole, 1 1/8 in.	1	1
JA12	117666	TERMINAL, ground	1	1
JA13	115942	NUT, hex, flange head	1	1
JA14	109466	NUT, lock, hex	2	2
JA16	122313	BAR, ground, kit	1	1
JA18	127908	NUT, flange, serrated, #10-32,ss	4	2
JA22‡	18B096	HARNESS, circuit brkr to light	1	1
JA24‡	18B091	HARNESS, ter blk to circuit breaker, 240V	1	1
JA25‡	18B093	HARNESS, circuit breaker to sw1 & sw2	1	1
JA26‡	18B094	HARNESS, circuit breaker to sw3 & sw4	1	1
JA27‡	18B089	HARNESS, disc to ter block, 240V	1	1
JA28‡	17N595	WIRE, ground, door to enclosure	1	1
JA29	17N594	WIRE, ground, gnd1 to gnd2	1	1
JA30‡	18B095	HARNESS, circuit breaker to sw5	1	1
JA31	114421	BUSHING, strain relief	1	1
JA35	555629	WASHER, #10 lock external	2	2
JA36	558685	WASHER, 1/4 external tooth lock	1	1
JA37▲	15F674	LABEL, safety, motor	1	1
JA39	130296	MODULE, led, 240V, green	1	1
JA40	130344	LIGHT, indicating, green lens	1	1
JA41▲	25E178	LABEL, safety, danger	1	1
JA43‡	18B901	HARNESS, electric hose, 240V	1	
JA44	19B138	MODULE, temperature controller	1	
JA45*	25V538	MODULE, din rail, ASM, 240, breaker	1	

▲ Replacement safety labels, tags, and cards are available at no cost.

‡ Not shown.

* Series A module has OBS components; to replace older modules; 26C911 and 25V538 are required.

DIN Rail (240V Non-Hazardous Locations)

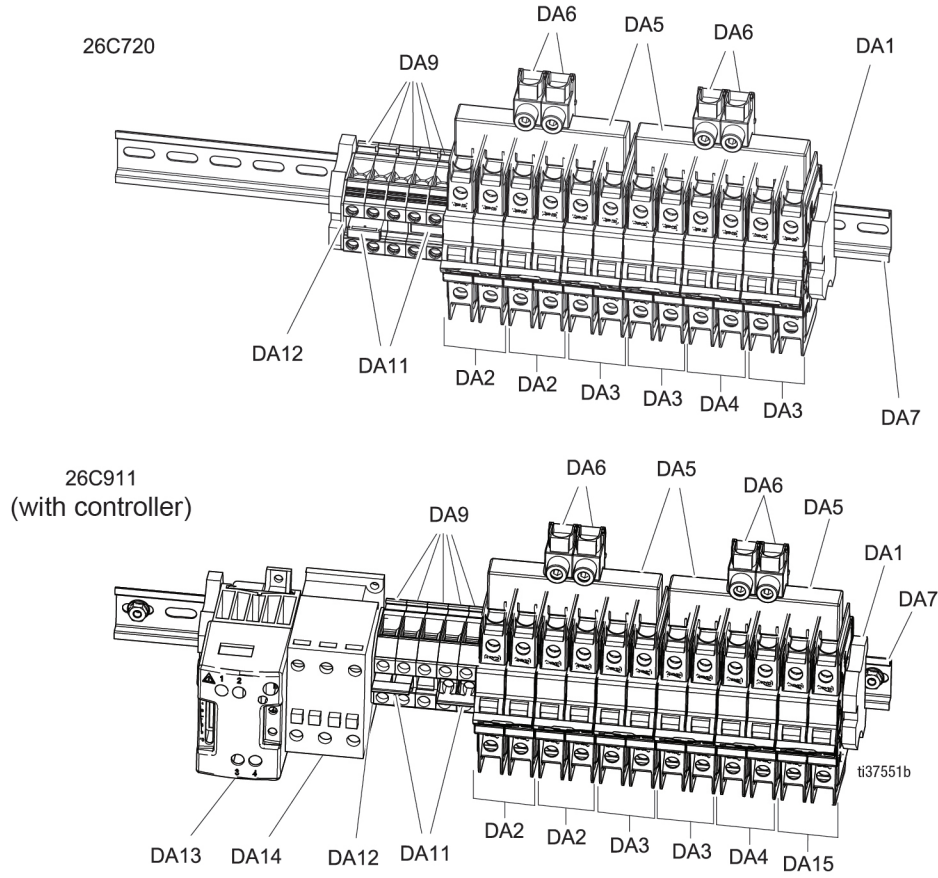

Ref.	Part	Description	Qty.	
			26C720	26C911
DA1	120838	BLOCK, clamp end	2	3
DA2	17A314	CIRCUIT, breaker, 2p, 20A, UL489, ab	2	2
DA3	17A315	CIRCUIT, breaker, 2p, 25A, UL489, ab	3	3
DA4	17C190	CIRCUIT, breaker, 2p, 1A, UL489, ab	1	1
DA5	17N690	BAR, power bus, 2p, 6 pin	2	2
DA6	17N691	CONNECTOR, terminal, bus bar	4	4
DA7		RAIL, mount (cut to length 1.47 in.)	1	1
DA9	18B664	BLOCK, terminal, 100A	5	5
DA10	18B831	MARKER, block, terminal, TB11-TB15	5	5
DA11	<i>See table below</i>			
DA12	18B666	BLOCK, cover end	1	1
DA13	19B128	RELAY, solid state, 18A, 240V		1
DA14	19B146	RELAY, contactor, 30A, 3p		1

Ref.	Date Code	Part	Description	Qty.	
				26C720	26C911
DA11	Prior to J20A	132804	BRIDGE, screw-in, 2-pos (jumper)	2	2
	After J20A	132805	BRIDGE, screw-in, 3-pos (jumper)	1	1

480V Non-Hazardous Locations Parts (26C904 shown)

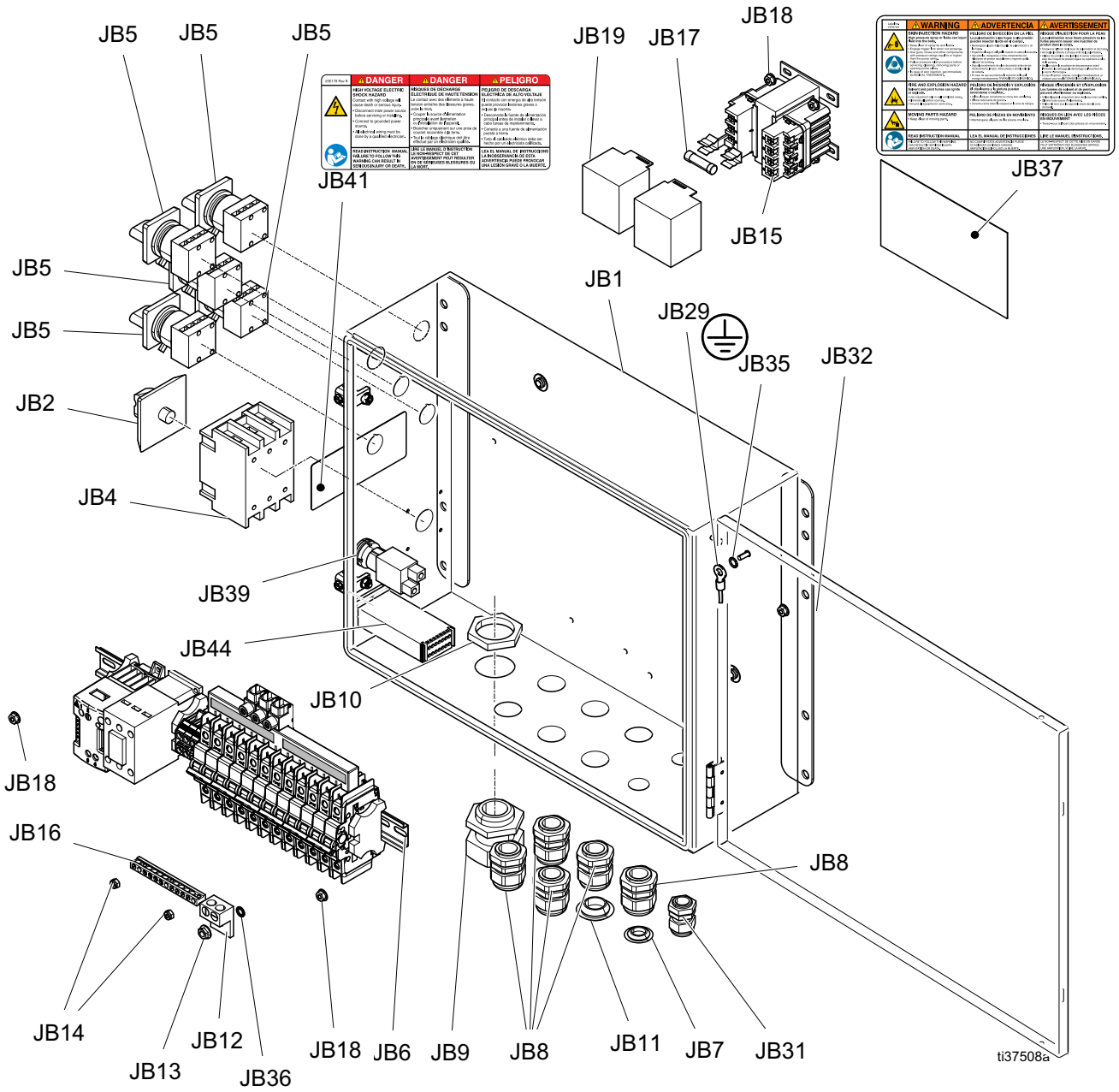

480V Non-Hazardous Locations Parts List

Ref.	Part	Description	Qty.	
			26C582	26C904
JB1	18A497	ENCLOSURE, electrical, XP/XM	1	1
JB2	123967	KNOB, operator disconnect	1	1
JB4	123969	SWITCH, disconnect, 100A (E-30/)	1	1
JB5	15U423	SWITCH, 2P, 25A	5	5
JB6	26C721	MODULE, din rail ASM, 480V, breaker (see page 26)	1	
	26C912	MODULE, din rail ASM, 480V, with controller (see page 26)		1
JB7	15U543	PLUG, hole, 7/8 in.	1	1
JB8	116171	BUSHING, strain relief	5	5
JB9	120858	BUSHING, strain relief, M40 thread	1	1
JB10	120859	NUT, strain relief, M40 thread	1	1
JB11	15U544	PLUG, hole, 1 1/8 in.	1	1
JB12	117666	TERMINAL, ground	1	1
JB13	115942	NUT, hex, flange head	1	1
JB14	109466	NUT, lock, hex	2	2
JB15	18A373	TRANSFORMER, 240/480 x 120/240	1	1
JB16	122313	BAR, ground, kit	1	1
JB17	18A398	FUSE, 1/2 amp	1	1
JB18	127908	NUT, flange, serrated, #10-32, ss	6	6
JB19	18B226	COVER, terminal, transformer	2	2
JB21‡	18B100	HARNESS, Xformer to terminal block	1	1
JB22‡	18B096	HARNESS, circuit breaker to light	1	1
JB25‡	18B093	HARNESS, circuit breaker to SW1 & SW2	1	1
JB26‡	18B094	HARNESS, circuit breaker to SW3 & SW4	1	1
JB27‡	18B090	HARNESS, disc to ter block, 480V	1	1
JB28‡	17N595	WIRE, ground, door to enclosure	1	1
JB29	17N594	WIRE, ground, gnd1 to gnd2	1	1
JB30‡	18B095	HARNESS, circuit breaker to SW5	1	1
JB31	114421	BUSHING, strain relief	1	1
JB35	555629	WASHER, #10 lock external	2	2
JB36	558685	WASHER, 1/4 external tooth lock	1	1
JB37▲	15F674	LABEL, safety, motor	1	1
JB39	131618	LIGHT, indicating, green, 480V	1	1
JB41▲	25E178	LABEL, safety, danger	1	1
JB43‡	18B902	HARNESS, electric hose, 480V		1
JB44	19B138	MODULE, temperature controller		1

▲ Replacement safety labels, tags, and cards are available at no cost.

‡ Not shown.

DIN Rail (480V Non-Hazardous Locations)

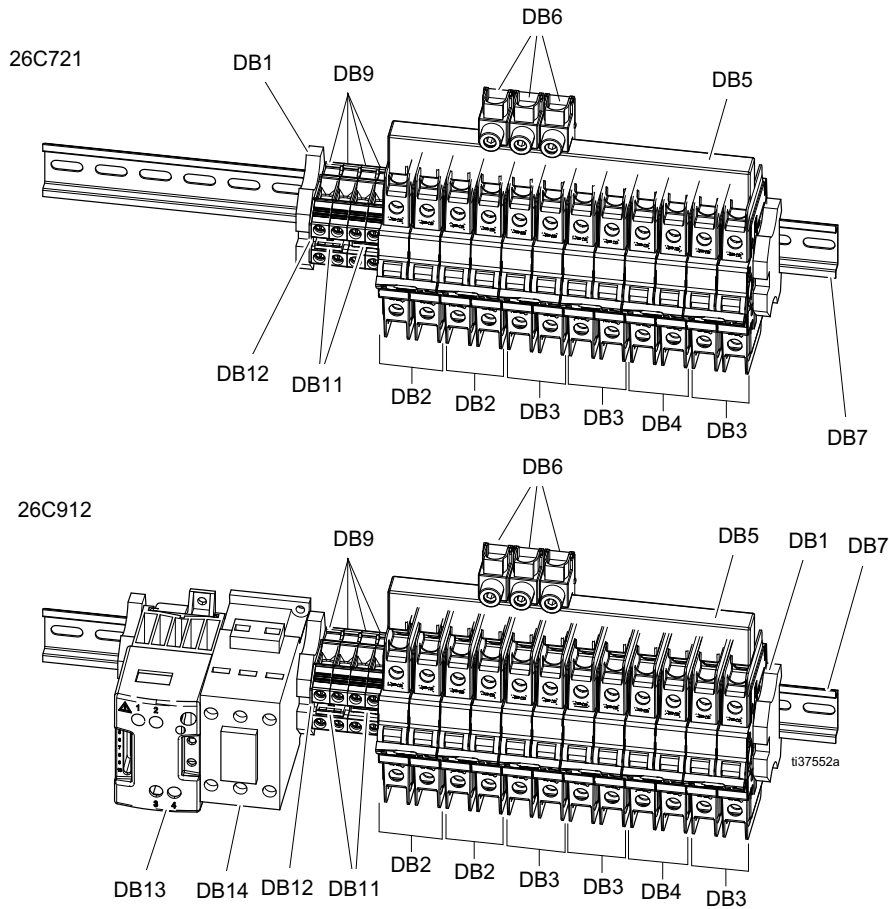

Ref.	Part	Description	Qty.	
			26C721	26C912
DB1	120838	BLOCK, clamp end	2	3
DB2	17A311	CIRCUIT, breaker, 2p, 10A, UL489, ab	2	2
DB3	17A313	CIRCUIT, breaker, 2p, 15A, UL489, ab	3	3
DB4	17C190	CIRCUIT, breaker, 2p, 1A, UL489, ab	1	1
DB5	18A195	BAR, power bus, 3p, 12 pin	1	1
DB6	17N691	CONNECTOR, terminal, bus bar	3	3
DB7		RAIL, mount, (but to length 1.47 in.)	1	1
DB9	18B833	BLOCK, terminal, 60A	4	4
DB11	<i>See table below.</i>			
DB12	18B832	BLOCK, cover, end	1	1
DB13	19B132	RELAY, solid state, 480V		1
DB14	19B146	RELAY, contactor, 30A, 3p		1

Ref.	Date Code	Part	Description	Qty.	
				26C721	26C912
DB11	Prior to J20A	132804	BRIDGE, screw-in, 2-pos (jumper)	2	2
	After J20A	132805	BRIDGE, screw-in, 3-pos (jumper)	1	1

240V Hazardous Location Parts (26C905 shown)

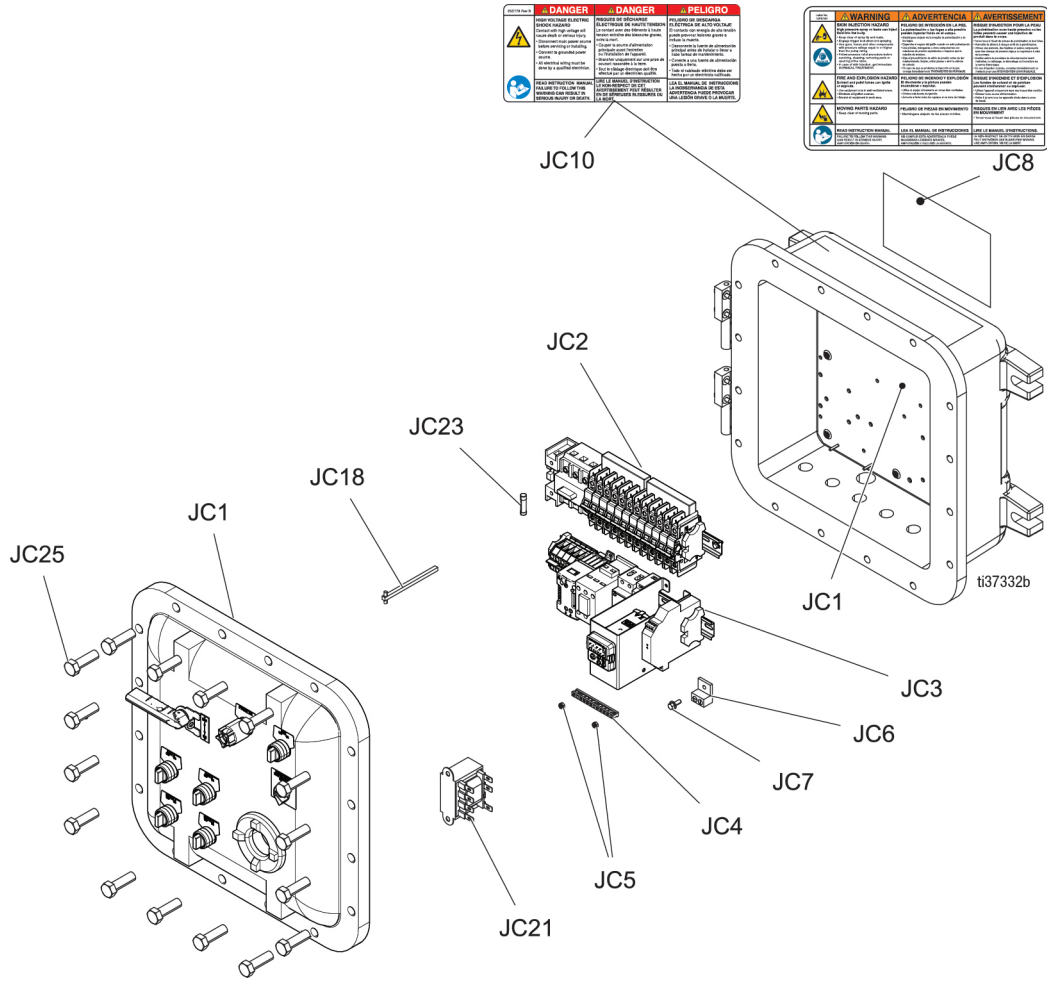

Ref.	Part	Description	Qty.	
			25C581	26C905
JC1	18B774	ENCLOSURE	1	1
JC2	26C907	MODULE, din rail	1	
	273218	MODULE, din rail		1
JC3	26C909	MODULE, din rail	1	
	26C939	MODULE, din rail		1
JC4	122313	BAR, ground	1	1
JC5	109466	NUT, lock	1	1
JC6	117666	TERMINAL, ground	2	2
JC7	131327	BOLT, flange head	1	1
JC8▲	15F674	LABEL, safety, motor	1	1
JC10▲	25E178	LABEL, safety, danger	1	1
JC11	19B245	LABEL, warning (not shown)	1	1
JC13	19B247	BRACKET, datatrak mount	1	1
JC14	19B248	BRACKET, datatrak mount	1	1
JC15	19B249	BRACKET, datatrak mount		1
JC16	19B250	BRACKET, datatrak mount	1	1
JC17	19B276	WIRE, ground	1	1
JC18	19B284	SHAFT, disconnect	1	1
JC19	17N594	WIRE, ground	1	1
JC25	16M007	SCREW	4	8
JC26	18C142	HARNESS, electric hose (not shown)		1
JC27	18B863	BARRIER		1
JC28	19B135	MODULE, temp control		1
JC29	19Y775	PLATE, mount	1	1
JC30	19B127	SENSOR, temp		1

▲ Replacement safety labels, tags, and cards are available at no cost.

DIN Rail (240V Hazardous Locations)

26C907 Parts

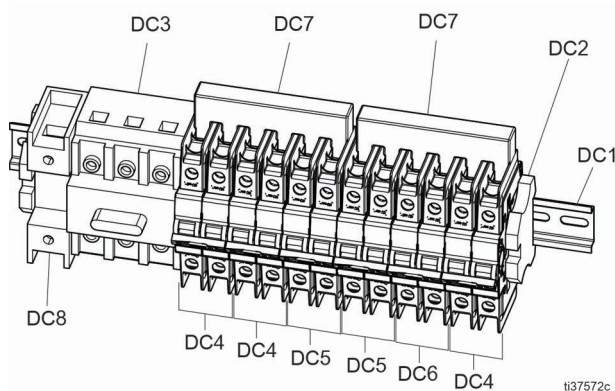

Ref. Part	Description	Qty.
DC1 - - - - -	RAIL, mount, (cut to length 1.47 in.)	1
DC2 120838	BLOCK, clamp end	2
DC3 125678	SWITCH, disconnect	1
DC4 17A314	CIRCUIT, breaker, 2p, 20A, UL489, ab	2
DC5 17A315	CIRCUIT, breaker, 2p, 25A, UL489, ab	3
DC6 17C190	CIRCUIT, breaker, 2p, 1A, UL489, ab	1
DC7 17N690	BAR, power bus, 2p, 6 pin	2
DC8 19B270	SWITCH, disconnect	1

26C939 Parts (no electric heat)

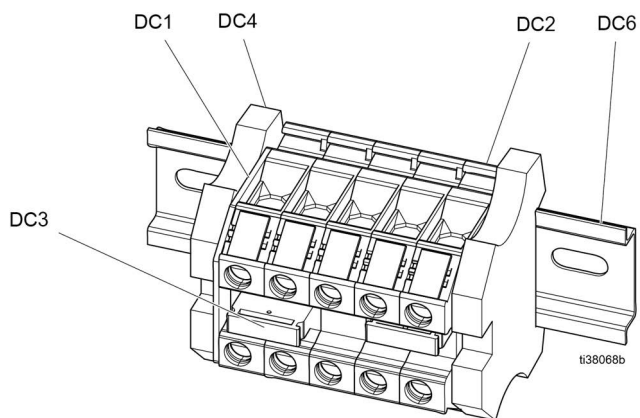

Ref. Part	Description	Qty.
DC1 - - - - -	BLOCK, cover end	1
DC2 132803	BLOCK, terminal, 100A	5
DC3	See table below	
DC4 120838	BLOCK, clamp end	2
DC6 - - - - -	RAIL, mt., 0.417 in. (cut to length at assembly)	1

26C909 Parts (with electric heat)

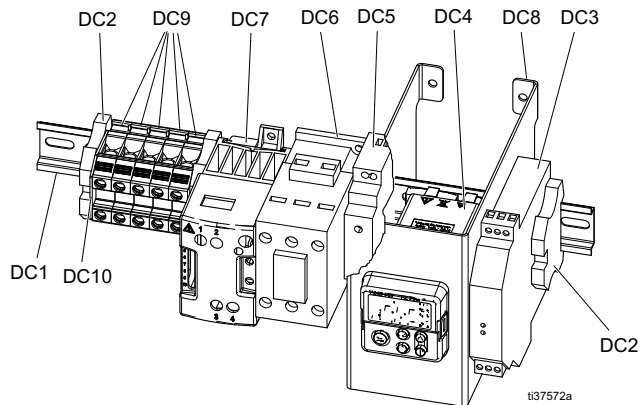

Ref. Part	Description	Qty.
DC1 - - - - -	RAIL, mount, (cut to length 1.15 in.)	1
DC2 120838	BLOCK, clamp end	3
DC3 19B133	BARRIER, i.s.	1
DC4 19B135	MODULE, temperature control	1
DC5 19B134	POWER SUPPLY, 240V, 24V	1
DC6 19B146	RELAY, contactor, 30A, 3p	1
DC7 19B128	RELAY, solid state, 18A, 240V	1
DC8 18B863	BARRIER, hazardous	1
DC9 132803	BLOCK, terminal, 100a	5
DC10 - - - - -	BLOCK, cover end	1

Ref.	Date Code	Part	Description	Qty.
DC3	Prior to J20A	132804	BRIDGE, screw-in, 2-pos (jumper)	2
	After J20A	132805	BRIDGE, screw-in, 3-pos (jumper)	1

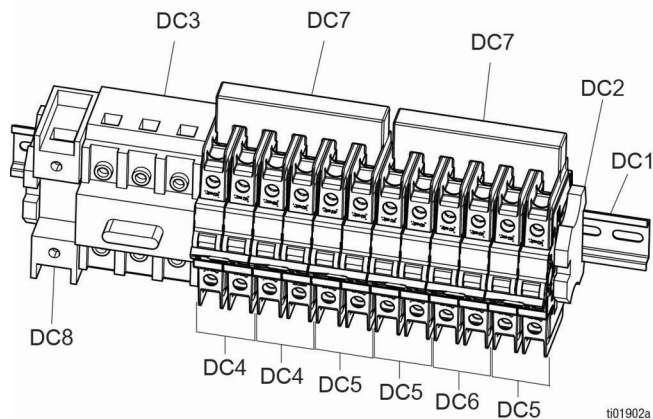

480V Hazardous Location (26C906 shown)

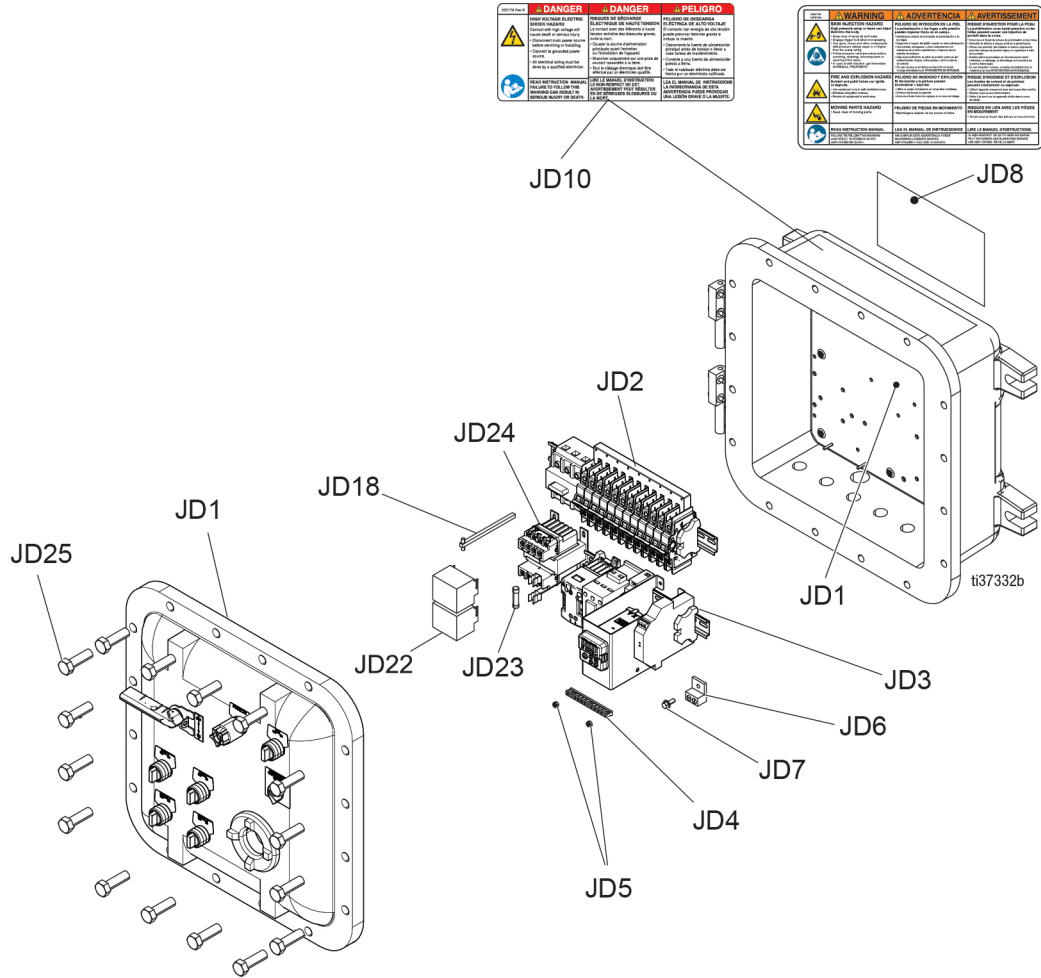

Ref.	Part	Description	Qty.	
			25C583	26C906
JC1	18B774	ENCLOSURE	1	1
JC2	26C908	MODULE, din rail	1	1
JC3	26C910	MODULE, din rail		1
JC4	122313	BAR, ground	1	1
JC5	109466	NUT, lock	1	1
JC6	117666	TERMINAL, ground	2	2
JC7	131327	BOLT, flange head	1	1
JC8▲	15F674	LABEL, safety, motor	1	1
JC10▲	25E178	LABEL, safety, danger	1	1
JC11	19B245	LABEL, warning (not shown)	1	1
JC15	19B249	BRACKET, datatrak mount		1
	19B250	BRACKET, datatrak mount	1	
JC17	19B276	WIRE, ground	1	1
JC18	19B284	SHAFT, disconnect	1	1
JC19	17N594	WIRE, ground	1	1
JC22	18B226	COVER	1	1
JC23	18A398	FUSE	1	1
JC24	18A373	TRANSFORMER	1	1
JC25	16M007	SCREW	4	8
JC26	18C142	HARNESS, electric hose (not shown)		1
JC27	18B863	BARRIER		1
JC28	19B135	MODULE, temp control		1
JC29	19Y775	PLATE, mount	1	1
JC30	19B127	SENSOR, temp		1

▲ Replacement safety labels, tags, and cards are available at no cost.

DIN Rail (480V Hazardous Locations)

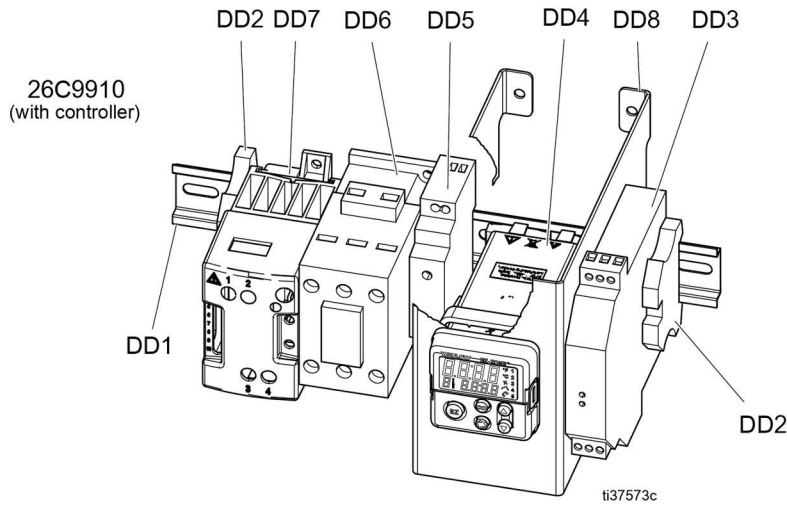
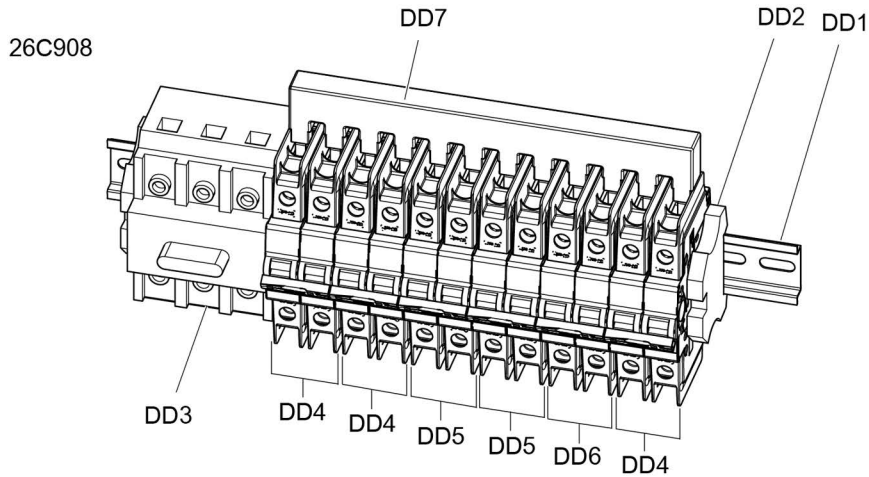

26C908 Parts List

Ref. Part	Description	Qty.
DD1	RAIL, mount (cut to length 1.47 in.)	1
DD2	120838 BLOCK, clamp end	2
DD3	125678 SWITCH, disconnect	1
DD4	17A314 CIRCUIT, breaker, 2p, 20A, UL489, ab	2
DD5	17A315 CIRCUIT, breaker, 2p, 25A, UL489, ab	3
DD6	17C190 CIRCUIT, breaker, 2p, 1A, UL489, ab	1
DD7	18A195 BAR, power bus, 3p, 12 pin	1

26C910 Parts List

Ref. Part	Description	Qty.
DD1	RAIL, mount (cut to length 1.91 in.)	1
DD2	120838 BLOCK, clamp end	2
DD3	19B133 BARRIER, i.s.	1
DD4	19B135 MODULE, temperature control	1
DD5	19B134 POWER SUPPLY, 240V/24V	1
DD6	19B146 RELAY, contactor, 30A, 3p	1
DD7	19B132 RELAY, solid state, 480V	1
DD8	18B863 BARRIER, hazardous	1

Wiring Schematics

Water Heated Hose - 240V Non-Hazardous Locations

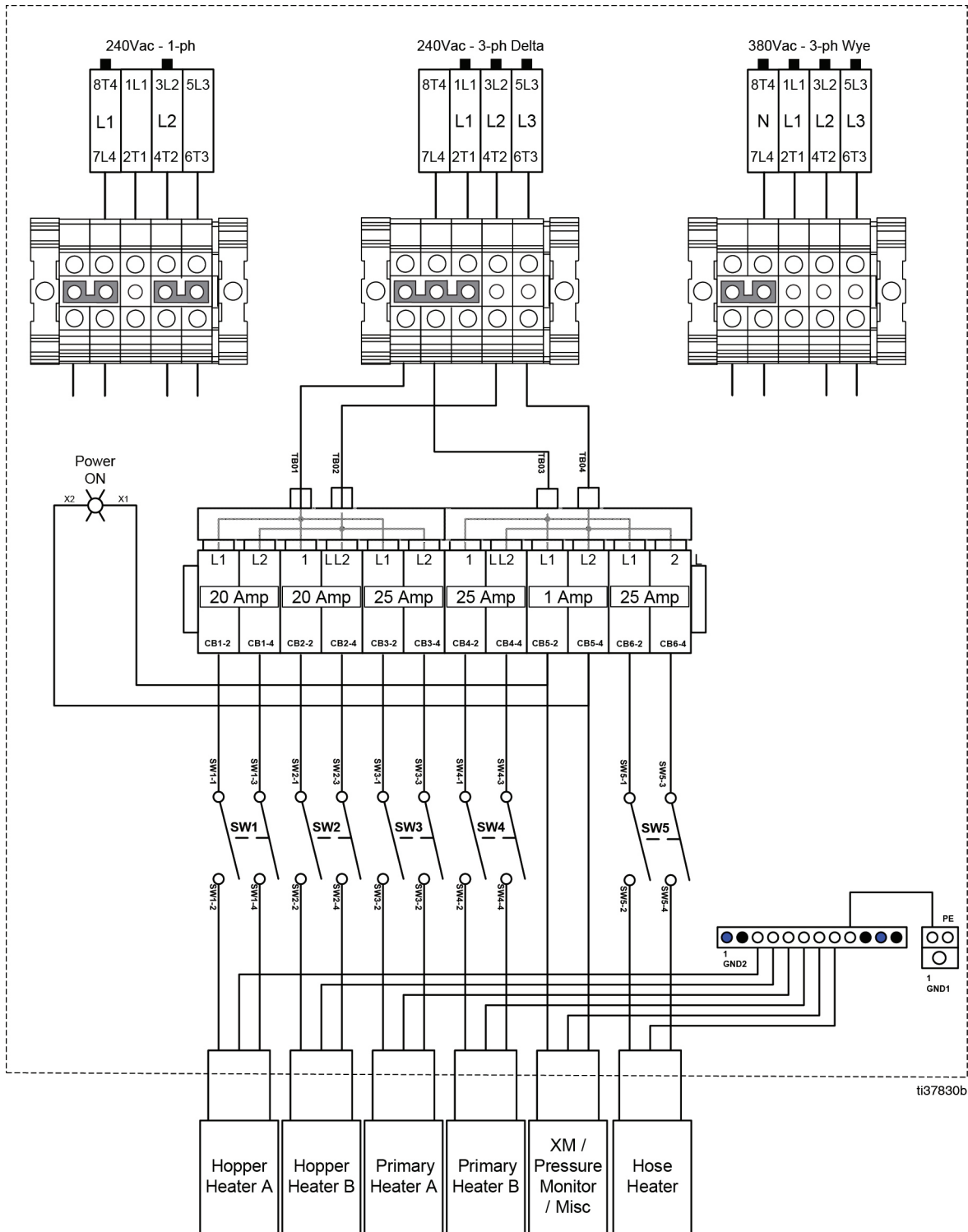

ti37830b

Water Heated Hose - 240V Hazardous Locations

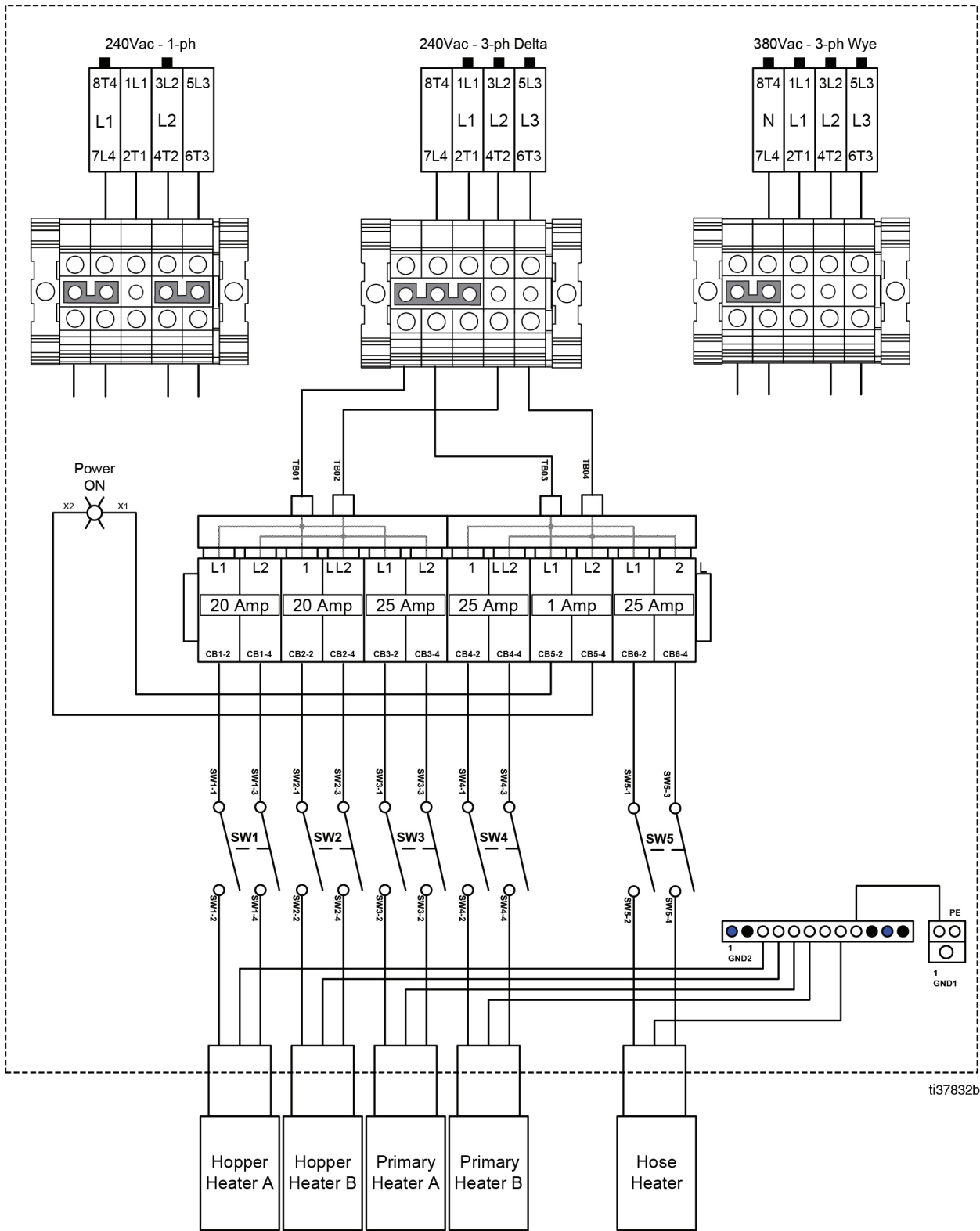

Water Heated Hose - 480V Non-Hazardous Locations

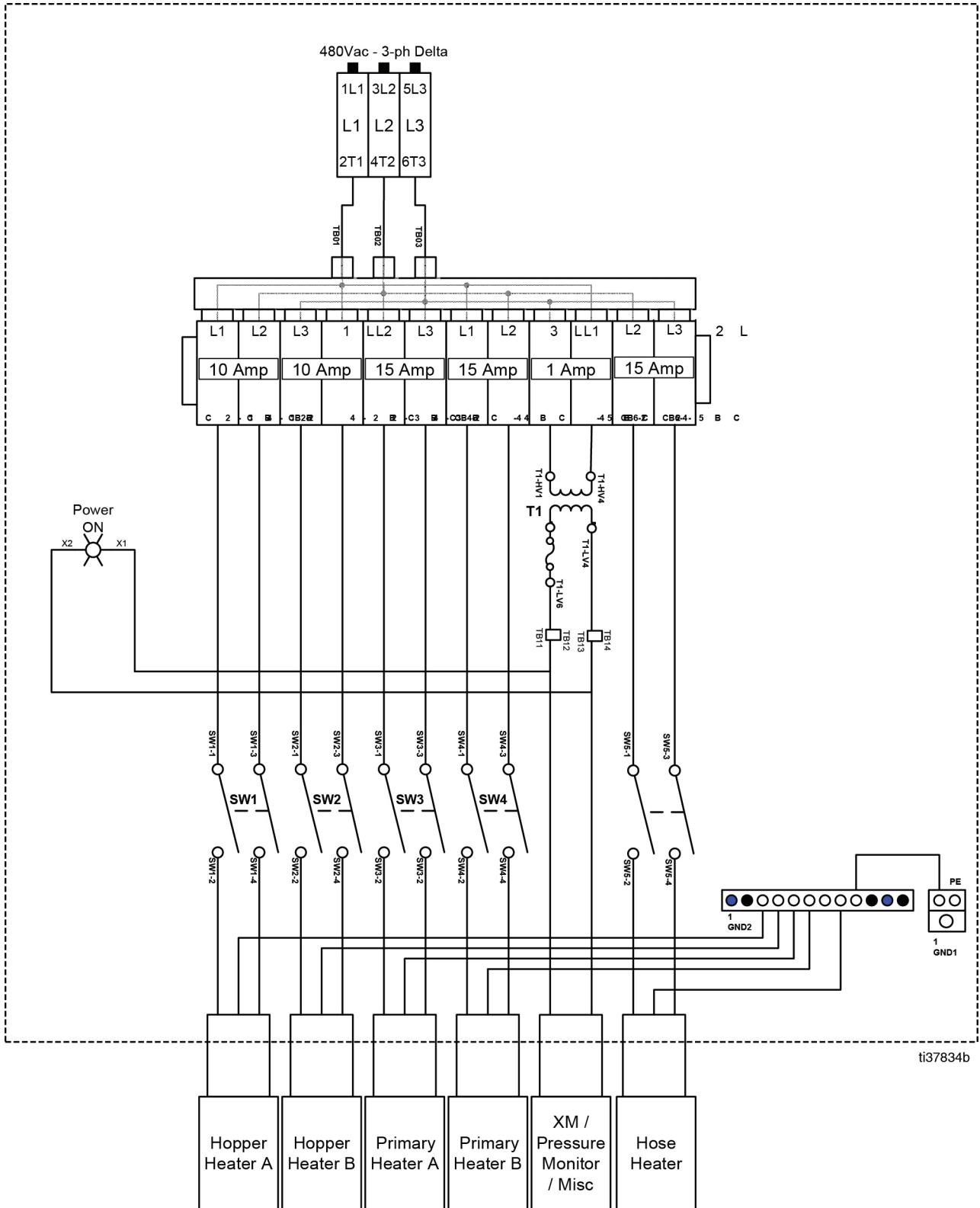

Water Heated Hose - 480V Hazardous Locations

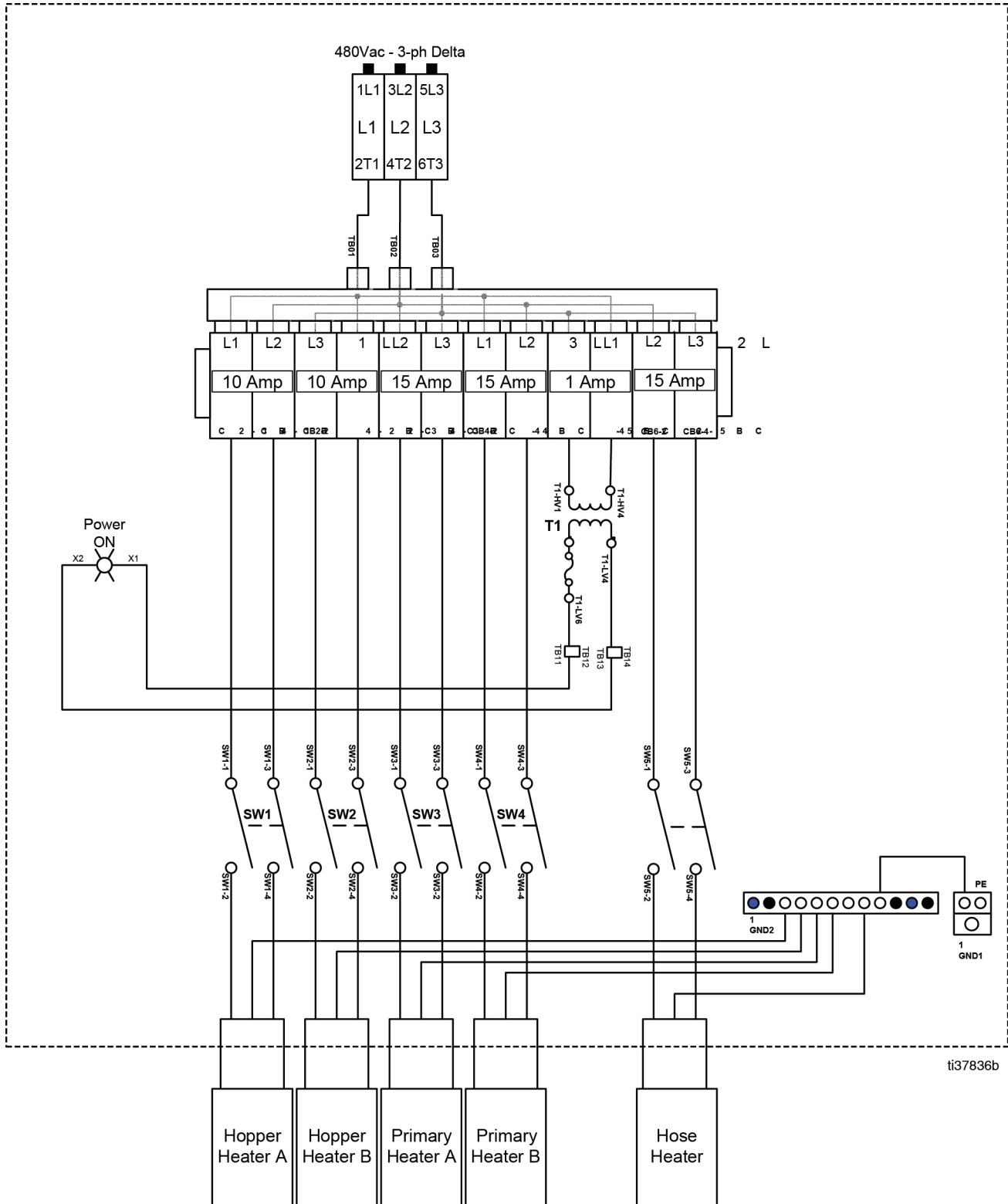

Electric Heated Hose - 240V Non-Hazardous Locations Series A

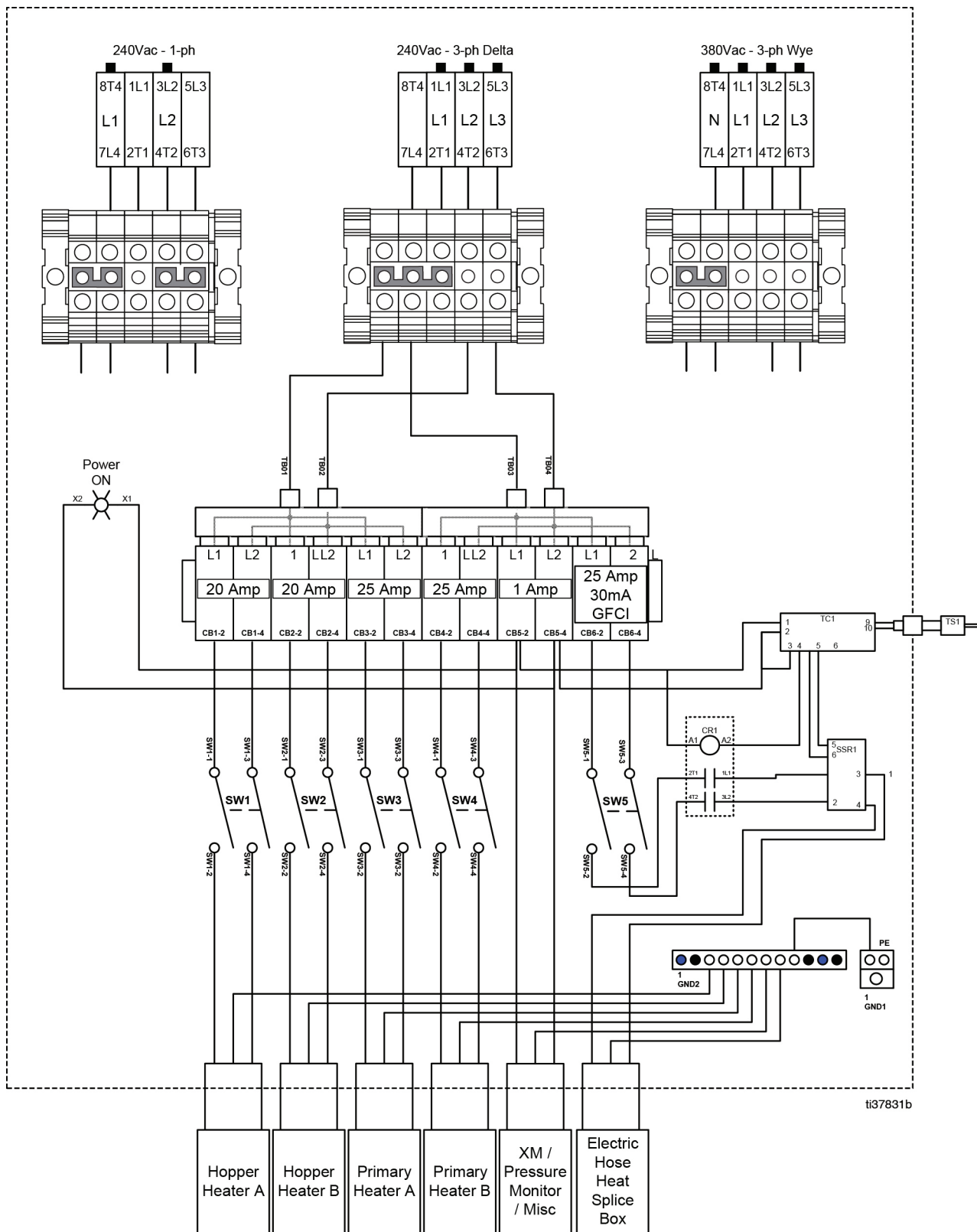

Electric Heated Hose - 240V Non-Hazardous Locations Series B

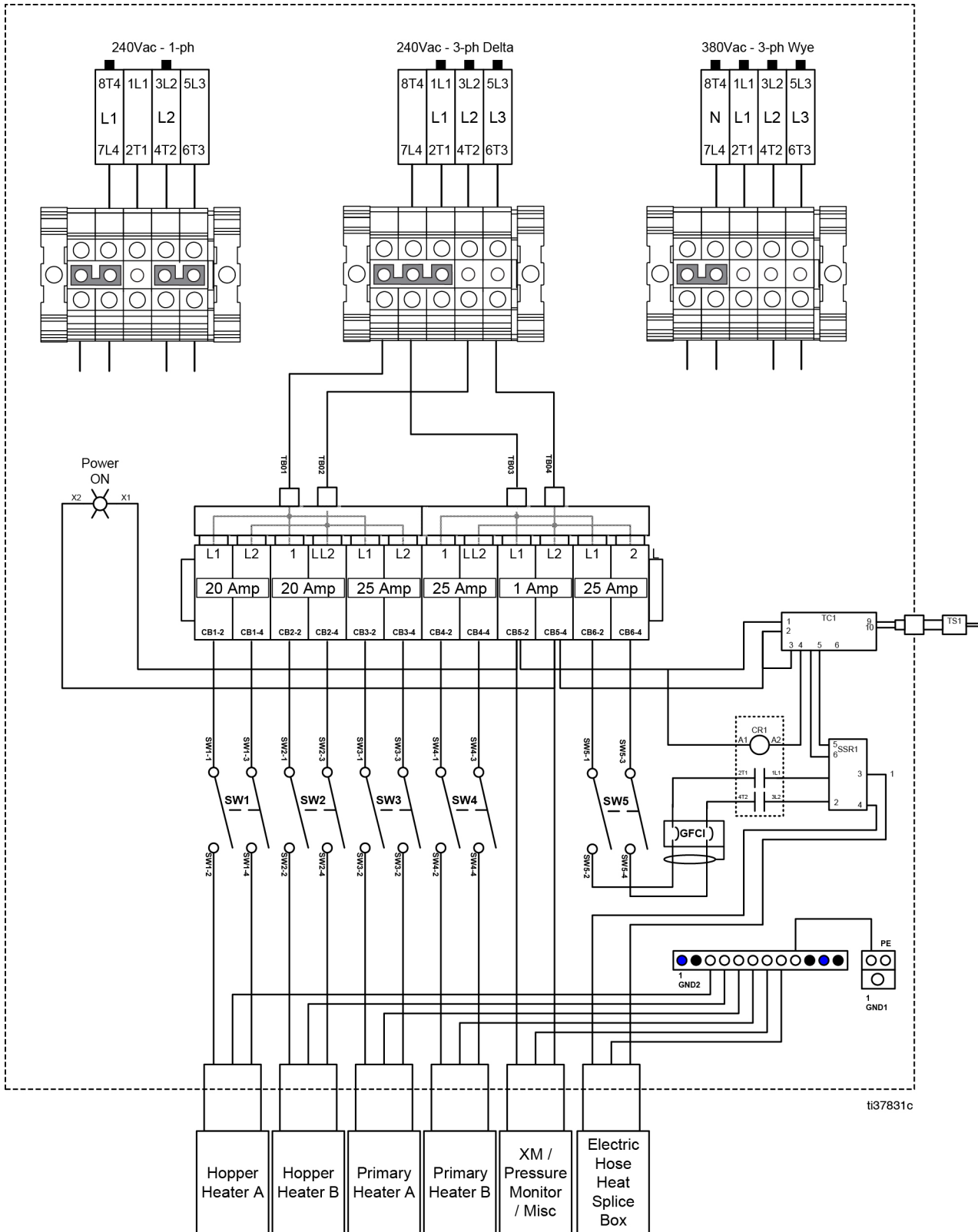

Electric Heated Hose - 240V Hazardous Locations Series A

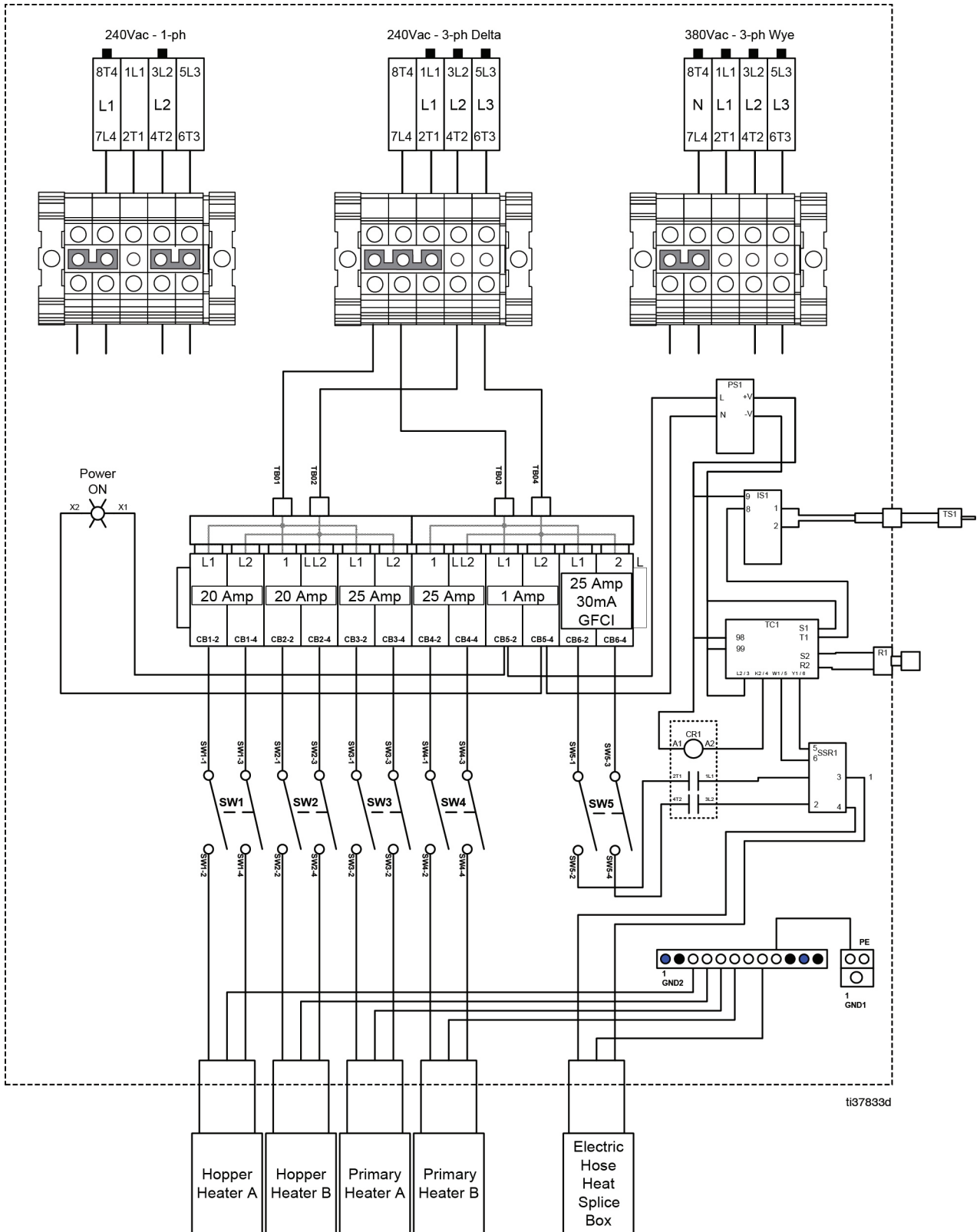

Electric Heated Hose - 480V Hazardous Locations

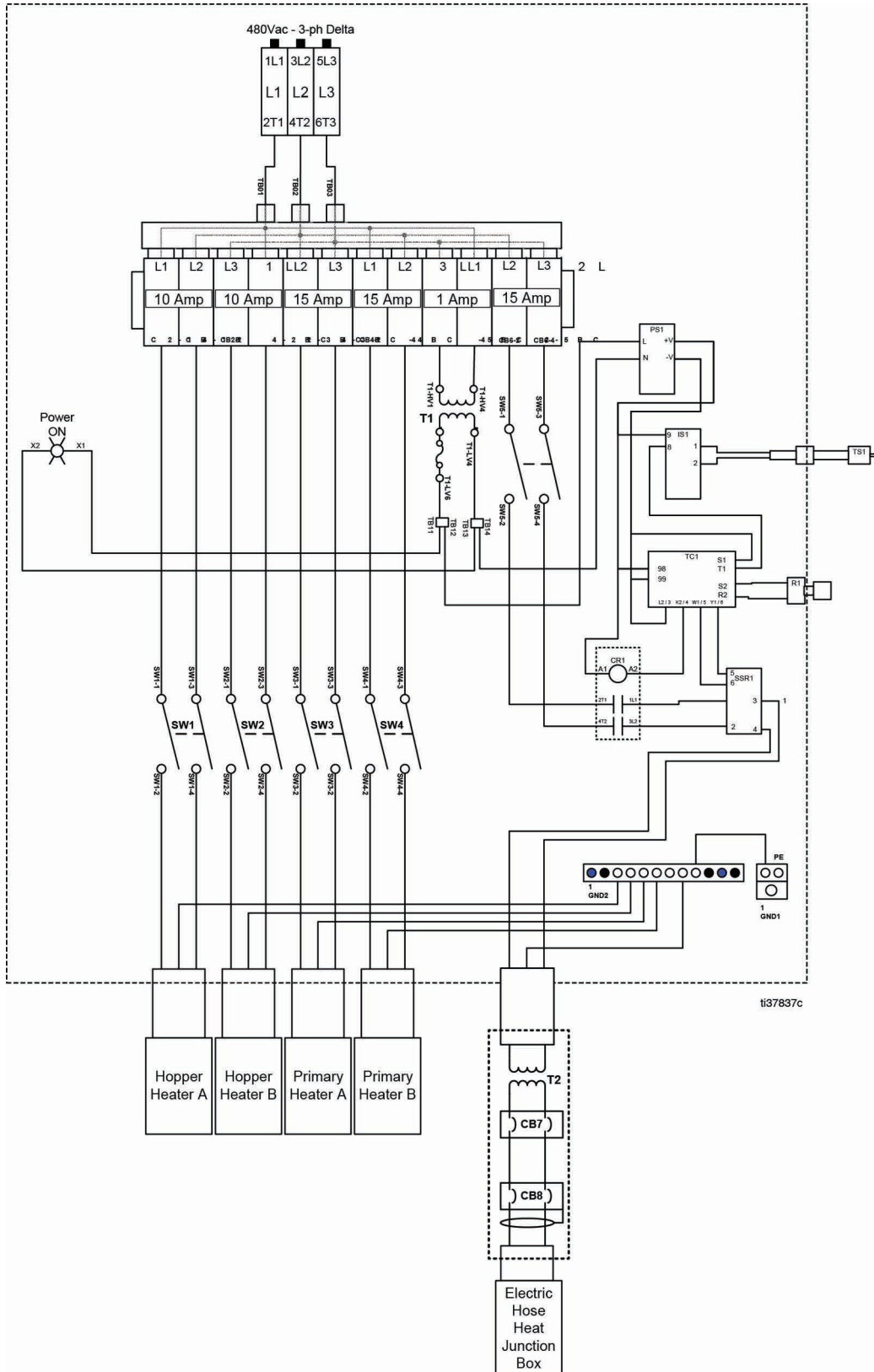

ti37837c

Recycling and Disposal

End of Product Life

At the end of the product's useful life, recycle it in a responsible manner.

California Proposition 65

CALIFORNIA RESIDENTS

 **WARNING:** Cancer and reproductive harm – www.P65warnings.ca.gov.

Technical Specifications

Junction Box Electrical Enclosures (Non-Hazardous Locations) 26C580, 26C582, 26C899, 26C904		
	US	Metric
Electrical Specifications (Configuring Voltage, Phase, Frequency, and Full Load Current):		
26C580 26C899	200V - 240V, 1 phase, 50/60 Hz, 87 A	
	200V - 240V, 3 phase, 50/60 Hz, 78 A	
	350V - 415V, 3 phase, 50/60 Hz, 46 A	
26C904 26C582	480V, 3 phase, 60 Hz, 28 A	
Dimensions:		
Width	22.25 in.	56.52 cm
Height	16.15 in.	41.0 cm
Depth	6.28 in.	15.95 cm
Weight:		
26C899 - 240V Non-Hazardous Locations with Heat	33.0 lb	14.9 kg
26C580 - 240V Non-Hazardous Locations	32.0 lb	14.5 kg
26C904 - 480V Non-Hazardous Locations with Heat	36.0 lb	16.3 kg
26C582 - 480V Non-Hazardous Locations	35.0 lb	15.8 kg

Junction Box Electrical Enclosures (Hazardous Locations) 26C581, 26C583, 26C905, 26C906		
	US	Metric
Electrical Specifications (Configuring Voltage, Phase, Frequency, and Full Load Current):		
26C581 26C905	200V - 240V, 1 phase, 50/60 Hz, 87 A	
	200V - 240V, 3 phase, 50/60 Hz, 78 A	
	350V - 415V, 3 phase, 50/60 Hz, 46 A	
26C904 26C582	480V, 3 phase, 60 Hz, 28 A	
Dimensions:		
Width	22.34 in.	56.74 cm
Height	20.88 in.	53.03 cm
Depth	9.94 in.	25.24 cm
Weight:		
26C905 - 240V Hazardous Locations with Heat	153.0 lb	69.4 kg
26C581 - 240V Hazardous Locations	151.0 lb	68.5 kg
26C906 - 480V Hazardous Locations with Heat	155.0 lb	70.3 kg
26C583 - 480V Hazardous Locations	153.0 lb	69.3 kg

Graco Standard Warranty

Graco warrants all equipment referenced in this document which is manufactured by Graco and bearing its name to be free from defects in material and workmanship on the date of sale to the original purchaser for use. With the exception of any special, extended, or limited warranty published by Graco, Graco will, for a period of twelve months from the date of sale, repair or replace any part of the equipment determined by Graco to be defective. This warranty applies only when the equipment is installed, operated and maintained in accordance with Graco's written recommendations.

This warranty does not cover, and Graco shall not be liable for general wear and tear, or any malfunction, damage or wear caused by faulty installation, misapplication, abrasion, corrosion, inadequate or improper maintenance, negligence, accident, tampering, or substitution of non-Graco component parts. Nor shall Graco be liable for malfunction, damage or wear caused by the incompatibility of Graco equipment with structures, accessories, equipment or materials not supplied by Graco, or the improper design, manufacture, installation, operation or maintenance of structures, accessories, equipment or materials not supplied by Graco.

This warranty is conditioned upon the prepaid return of the equipment claimed to be defective to an authorized Graco distributor for verification of the claimed defect. If the claimed defect is verified, Graco will repair or replace free of charge any defective parts. The equipment will be returned to the original purchaser transportation prepaid. If inspection of the equipment does not disclose any defect in material or workmanship, repairs will be made at a reasonable charge, which charges may include the costs of parts, labor, and transportation.

THIS WARRANTY IS EXCLUSIVE, AND IS IN LIEU OF ANY OTHER WARRANTIES, EXPRESS OR IMPLIED, INCLUDING BUT NOT LIMITED TO WARRANTY OF MERCHANTABILITY OR WARRANTY OF FITNESS FOR A PARTICULAR PURPOSE.

Graco's sole obligation and buyer's sole remedy for any breach of warranty shall be as set forth above. The buyer agrees that no other remedy (including, but not limited to, incidental or consequential damages for lost profits, lost sales, injury to person or property, or any other incidental or consequential loss) shall be available. Any action for breach of warranty must be brought within two (2) years of the date of sale.

GRACO MAKES NO WARRANTY, AND DISCLAIMS ALL IMPLIED WARRANTIES OF MERCHANTABILITY AND FITNESS FOR A PARTICULAR PURPOSE, IN CONNECTION WITH ACCESSORIES, EQUIPMENT, MATERIALS OR COMPONENTS SOLD BUT NOT MANUFACTURED BY GRACO. These items sold, but not manufactured by Graco (such as electric motors, switches, hose, etc.), are subject to the warranty, if any, of their manufacturer. Graco will provide purchaser with reasonable assistance in making any claim for breach of these warranties.

In no event will Graco be liable for indirect, incidental, special or consequential damages resulting from Graco supplying equipment hereunder, or the furnishing, performance, or use of any products or other goods sold hereto, whether due to a breach of contract, breach of warranty, the negligence of Graco, or otherwise.

FOR GRACO CANADA CUSTOMERS

The Parties acknowledge that they have required that the present document, as well as all documents, notices and legal proceedings entered into, given or instituted pursuant hereto or relating directly or indirectly hereto, be drawn up in English. Les parties reconnaissent avoir convenu que la rédaction du présente document sera en Anglais, ainsi que tous documents, avis et procédures judiciaires exécutés, donnés ou intentés, à la suite de ou en rapport, directement ou indirectement, avec les procédures concernées.

Graco Information

For the latest information about Graco products, visit www.graco.com.

For patent information, see www.graco.com/patents.

**TO PLACE AN ORDER, contact your Graco distributor or call to identify the nearest distributor.
Phone: 612-623-6921 or Toll Free: 1-800-328-0211 Fax: 612-378-3505**

*All written and visual data contained in this document reflects the latest product information available at the time of publication.
Graco reserves the right to make changes at any time without notice.*

Original instructions. This manual contains English. MM 3A7523

Graco Headquarters: Minneapolis

International Offices: Belgium, China, Japan, Korea

GRACO INC. AND SUBSIDIARIES • P.O. BOX 1441 • MINNEAPOLIS MN 55440-1441 • USA
Copyright 2016, Graco Inc. All Graco manufacturing locations are registered to ISO 9001.

www.graco.com
Revision E, April 2024