

PSM

3A7273E

1K Precision Metering System

EN

For accurate metering and dispensing of single-component materials. For professional use only.

Not approved for use in explosive atmospheres or hazardous (classified) locations.

100 psi (0.7 MPa, 7 bar) Maximum Air Inlet Pressure.

See page 3 for model information, including maximum fluid working pressure and approvals.



Important Safety Instructions

Read all warnings and instructions in this manual before using the equipment. Save these instructions.

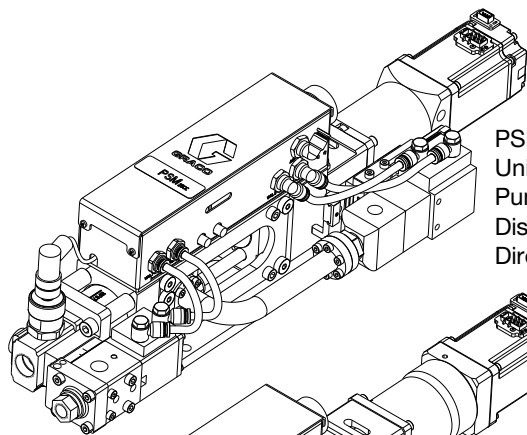

PSM Metering Unit, 25 cc, Supply Pump Feed, iQ Dispense Valve Direct Show

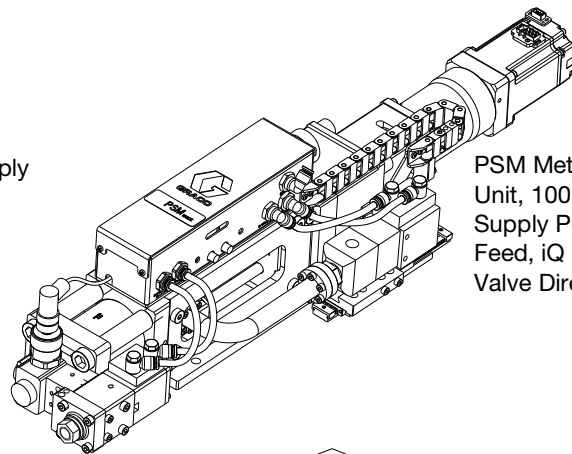

PSM Metering Unit, 100 cc, Supply Pump Feed, iQ Dispense Valve Direct Show

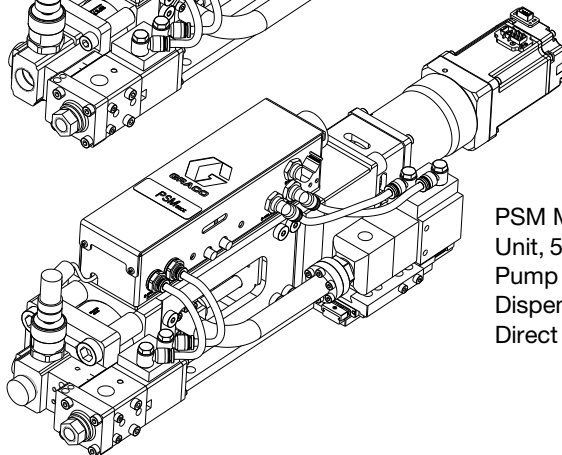

PSM Metering Unit, 50 cc, Supply Pump Feed, iQ Dispense Valve Direct Show

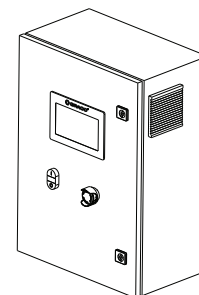

PSM Control Unit



Contents

Related Manuals	2
Models	3
Safety Symbols	4
General Warnings	5
Changing Materials	7
Typical Installation	8
Component Identification	9
PSM Metering Unit, Supply Pump Feed	9
PSM Control Unit	10
General Information	11
Installation	11
Unpacking	11
Locate and Install	12
Grounding	14
Power Requirements	14
System Connections	15
Flush Before Using Equipment	15
Startup	16
HMI Display Operation and Identification	17
Screen Navigation Diagrams	17
Automatic Screen 1 - Main	21
Automatic Screen 2 - Main	23
Automatic Screen 3 - Main	25
Automatic Screen 4 - Maintenance record	26
Automatic Screen 5 - Job history	26
Automatic Screen 6 - Error history	27
System Main Screen	27
Manual Screen 1	28
Manual Screen 2	29
Setup Screen	29
Advanced Screen	38
Operation	40
Prime the System	40
Daily Start Up	41
Weight Check	42
Add Communication Module	43
Shutdown	46
Pressure Relief Procedure	47
Flush the Equipment	47
Maintenance	48
Preventive Maintenance	48
Recycling and Disposal	49
End of Product Life	49
Troubleshooting	50

Dimensions	53
PSM Metering Unit, Supply Pump Feed, 25 cc	53
PSM Metering Unit, Supply Pump Feed, 50 cc	54
PSM Metering Unit, Supply Pump Feed, 100 cc	55
PSM Control Unit	56
Appendix A - PSM Error Codes	57
Schematics	61
Cables Route	64
Internal Cables	65
Terminal I/O Route	66
I/O Signals	67
Profinet map	68
Timing Chart	69
Technical Specifications	73
California Proposition 65	73
Graco Standard Warranty	74

Related Manuals

Manuals in English	Description
3A9277	PSM Repair and Parts Manual
308876	1K Ultra-Lite™ Instructions and Parts List Manual
333585	IQ Dispense Valves Instructions and Parts List Manual

Models

Part	Maximum Fluid Working Pressure psi (MPa, bar)	Description	Includes:		
			PSM Metering Unit	Dispense Valve	PSM Control Unit
25S141	1200 psi (8.3 MPa, 83 bar)	PSM System, 25 cc, Direct ⁽³⁾ , I/O ⁽⁴⁾ , SST ⁽¹⁾ , Snuff-Back	✓	✓	✓
25S148		PSM System, 25 cc, Direct ⁽³⁾ , I/O ⁽⁴⁾ , CER ⁽²⁾ , Snuff-Back	✓	✓	✓
2000828		PSM System, 25 cc, Direct ⁽³⁾ , I/O ⁽⁴⁾ , SST ⁽¹⁾ , Tip Seal	✓	✓	✓
2000829		PSM System, 25 cc, Direct ⁽³⁾ , I/O ⁽⁴⁾ , CER ⁽²⁾ , Tip Seal	✓	✓	✓
2001633		PSM System, 25 cc, Direct ⁽³⁾ , I/O ⁽⁴⁾ , SST ⁽¹⁾ , Ball Seal	✓	✓	✓
2001634		PSM System, 25 cc, Direct ⁽³⁾ , I/O ⁽⁴⁾ , CER ⁽²⁾ , Ball Seal	✓	✓	✓
2005191		PSM System, 25 cc, Direct ⁽³⁾ , I/O ⁽⁴⁾ , SST ⁽¹⁾ , without iQ Valve	✓		✓
2005192		PSM System, 25 cc, Direct ⁽³⁾ , I/O ⁽⁴⁾ , CER ⁽²⁾ , without iQ Valve	✓		✓
25S142	3000 psi (20.7 MPa, 207 bar)	PSM System, 50 cc, Direct ⁽³⁾ , I/O ⁽⁴⁾ , SST ⁽¹⁾ , Snuff-Back	✓	✓	✓
25S167		PSM System, 50 cc, Direct ⁽³⁾ , I/O ⁽⁴⁾ , CER ⁽²⁾ , Snuff-Back	✓	✓	✓
2000830		PSM System, 50 cc, Direct ⁽³⁾ , I/O ⁽⁴⁾ , SST ⁽¹⁾ , Tip Seal	✓	✓	✓
2000831		PSM System, 50 cc, Direct ⁽³⁾ , I/O ⁽⁴⁾ , CER ⁽²⁾ , Tip Seal	✓	✓	✓
2001635		PSM System, 50 cc, Direct ⁽³⁾ , I/O ⁽⁴⁾ , SST ⁽¹⁾ , Ball Seal	✓	✓	✓
2001636		PSM System, 50 cc, Direct ⁽³⁾ , I/O ⁽⁴⁾ , CER ⁽²⁾ , Ball Seal	✓	✓	✓
2005193		PSM System, 50 cc, Direct ⁽³⁾ , I/O ⁽⁴⁾ , SST ⁽¹⁾ , without iQ Valve	✓		✓
2005194		PSM System, 50 cc, Direct ⁽³⁾ , I/O ⁽⁴⁾ , CER ⁽²⁾ , without iQ Valve	✓		✓
25S143	3000 psi (20.7 MPa, 207 bar)	PSM System, 100 cc, Direct ⁽³⁾ , I/O ⁽⁴⁾ , SST ⁽¹⁾ , Snuff-Back	✓	✓	✓
25S170		PSM System, 100 cc, Direct ⁽³⁾ , I/O ⁽⁴⁾ , CER ⁽²⁾ , Snuff-Back	✓	✓	✓
2000832		PSM System, 100 cc, Direct ⁽³⁾ , I/O ⁽⁴⁾ , SST ⁽¹⁾ , Tip Seal	✓	✓	✓
2000833		PSM System, 100 cc, Direct ⁽³⁾ , I/O ⁽⁴⁾ , CER ⁽²⁾ , Tip Seal	✓	✓	✓
2001637		PSM System, 100 cc, Direct ⁽³⁾ , I/O ⁽⁴⁾ , SST ⁽¹⁾ , Ball Seal	✓	✓	✓
2001638		PSM System, 100 cc, Direct ⁽³⁾ , I/O ⁽⁴⁾ , CER ⁽²⁾ , Ball Seal	✓	✓	✓
2005195		PSM System, 100 cc, Direct ⁽³⁾ , I/O ⁽⁴⁾ , SST ⁽¹⁾ , without iQ Valve	✓		✓
2005196		PSM System, 100 cc, Direct ⁽³⁾ , I/O ⁽⁴⁾ , CER ⁽²⁾ , without iQ Valve	✓		✓

(1) SST: Stainless steel material

(2) CER: Ceramic material









(3) Any PSM system can be converted from direct connection mode to remote connection mode by using remote kits. See **Remote Kits** in your PSM Repair-Parts Manual and order remote kits. See **Related Manuals**, page 2.

(4) Any PSM system can be converted to Profinet or Ethernet IP communication mode. Order kit 2005273 for Profinet communication mode or kit 2000362 for Ethernet IP communication mode. See **Communication Module** in your PSM Repair-Parts Manual.

Safety Symbols

The following safety symbols appear throughout this manual and on warning labels. Read the table below to understand what each symbol means.

Symbol	Meaning
	Electric Shock Hazard
	Equipment Misuse Hazard
	Fire and Explosion Hazard
	Moving Parts Hazard
	Pressurized Equipment Hazard
	Skin Injection Hazard
	Skin Injection Hazard
	Splash Hazard
	Toxic Fluid or Fumes Hazard

Symbol	Meaning
	Do Not Place Hands or Other Body Parts Near Fluid Outlet
	Do Not Stop Leaks with Hand, Body, Glove or Rag
	Eliminate Ignition Sources
	Follow Pressure Relief Procedure
	Ground Equipment
	Read Manual
	Ventilate Work Area
	Wear Personal Protective Equipment











Safety Alert Symbol







This symbol indicates: Attention! Become Alert! Look for this symbol throughout the manual to indicate important safety messages.

General Warnings

The following warnings apply throughout this manual. Read, understand, and follow the warnings before using this equipment. Failure to follow these warnings can result in serious injury.

 WARNING	
 	<p>ELECTRIC SHOCK HAZARD</p> <p>This equipment must be grounded. Improper grounding, setup, or usage of the system can cause electric shock.</p> <ul style="list-style-type: none"> • Turn off and disconnect all power before disconnecting any cables and before servicing or installing equipment. • Connect only to grounded power source. • All electrical wiring must be done by a qualified electrician and comply with all local codes and regulations.
    	<p>SKIN INJECTION HAZARD</p> <p>High-pressure fluid from dispensing device, hose leaks, or ruptured components will pierce skin. This may look like just a cut, but it is a serious injury that can result in amputation. Get immediate surgical treatment.</p> <ul style="list-style-type: none"> • Do not point dispensing device at anyone or at any part of the body. • Do not put your hand over the fluid outlet. • Do not stop or deflect leaks with your hand, body, glove, or rag. • Follow the Pressure Relief Procedure in your PSM Instruction Manual when you stop dispensing and before cleaning, checking, or servicing equipment. • Tighten all fluid connections before operating the equipment. • Check hoses and couplings daily. Replace worn or damaged parts immediately.
	<p>TOXIC FLUID OR FUMES HAZARD</p> <p>Toxic fluids or fumes can cause serious injury or death if splashed in the eyes or on skin, inhaled, or swallowed.</p> <ul style="list-style-type: none"> • Read Safety Data Sheets (SDSs) to know the specific hazards of the fluids you are using. • Store hazardous fluid in approved containers, and dispose of it according to applicable guidelines.

WARNING

   	<p>FIRE AND EXPLOSION HAZARD</p> <p>Flammable fumes, such as solvent and paint fumes, in work area can ignite or explode. Paint or solvent flowing through the equipment can cause static sparking. To help prevent fire and explosion:</p> <ul style="list-style-type: none"> • Use equipment only in well-ventilated area. • Eliminate all ignition sources; such as pilot lights, cigarettes, portable electric lamps, and plastic drop cloths (potential static sparking). • Ground all equipment in the work area. See Grounding instructions in your PSM Instruction Manual. • Never spray or flush solvent at high pressure. • Keep work area free of debris, including solvent, rags and gasoline. • Do not plug or unplug power cords, or turn power or light switches on or off when flammable fumes are present. • Use only grounded hoses. • Hold gun firmly to side of grounded pail when triggering into pail. Do not use pail liners unless they are anti-static or conductive. • Stop operation immediately if static sparking occurs or you feel a shock. Do not use equipment until you identify and correct the problem. • Keep a working fire extinguisher in the work area.
 	<p>EQUIPMENT MISUSE HAZARD</p> <p>Misuse can cause death or serious injury.</p> <ul style="list-style-type: none"> • Do not operate the unit when fatigued or under the influence of drugs or alcohol. • Do not exceed the maximum working pressure or temperature rating of the lowest rated system component. See Technical Specifications in all equipment manuals. • Use fluids and solvents that are compatible with equipment wetted parts. See Technical Specifications in all equipment manuals. Read fluid and solvent manufacturer's warnings. For complete information about your material, request Safety Data Sheets (SDSs) from distributor or retailer. • Turn off all equipment and follow the Pressure Relief Procedure in your PSM Instruction Manual when equipment is not in use. • Check equipment daily. Repair or replace worn or damaged parts immediately with genuine manufacturer's replacement parts only. • Do not alter or modify equipment. Alterations or modifications may void agency approvals and create safety hazards. • Make sure all equipment is rated and approved for the environment in which you are using it. • Use equipment only for its intended purpose. Call your distributor for information. • Route hoses and cables away from traffic areas, sharp edges, moving parts, and hot surfaces. • Do not kink or over bend hoses or use hoses to pull equipment. • Keep children and animals away from work area. • Comply with all applicable safety regulations.

⚠️ WARNING



MOVING PARTS HAZARD

Moving parts can pinch, cut or amputate fingers and other body parts.



- Keep clear of moving parts.
- Do not operate equipment with protective guards or covers removed.
- Equipment can start without warning. Before checking, moving, or servicing equipment, follow the **Pressure Relief Procedure** in your PSM Instruction Manual and disconnect all power sources.



PERSONAL PROTECTIVE EQUIPMENT

Wear appropriate protective equipment when in the work area to help prevent serious injury, including eye injury, hearing loss, inhalation of toxic fumes, and burns. Protective equipment includes but is not limited to:

- Protective eyewear, and hearing protection.
- Respirators, protective clothing, and gloves as recommended by the fluid and solvent manufacturer.

Changing Materials

NOTICE

Changing the material types used in your equipment requires special attention to avoid equipment damage and downtime.

- When changing materials, flush the equipment multiple times to ensure it is thoroughly clean.
- Always clean the fluid inlet strainers after flushing.
- Check with your material manufacturer for chemical compatibility.
- When changing between epoxies and urethanes or polyureas, disassemble and clean all fluid components and change hoses. Epoxies often have amines on the B (hardener) side. Polyureas often have amines on the B (resin) side.

Typical Installation

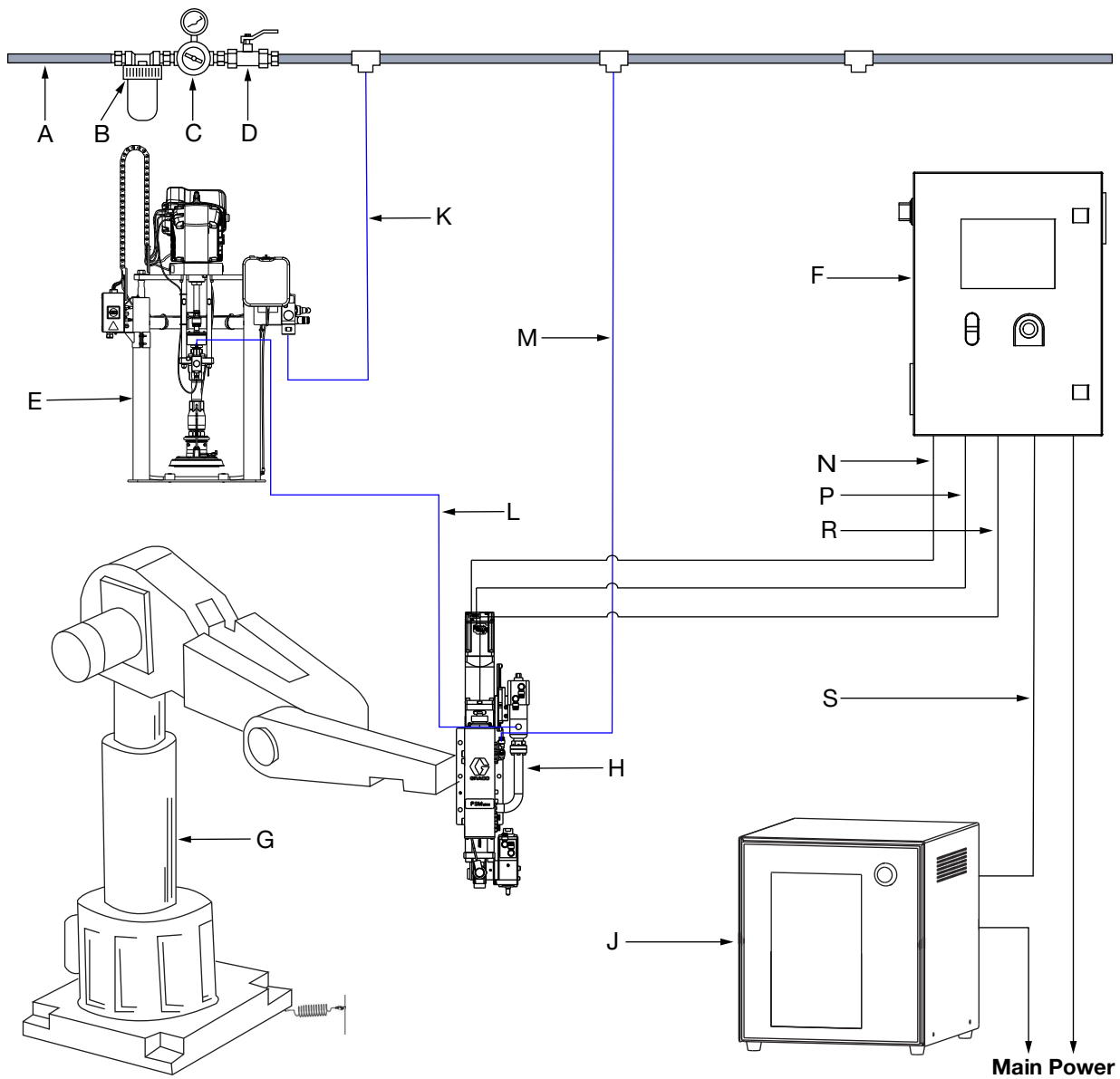

FIG. 1: Typical Installation

Key:

- A Main Air Line
- B Air Filter ⁽¹⁾
- C Pressure Regulator Valve ⁽¹⁾
- D Bleed-type Master Air Valve ⁽¹⁾
- E Supply Pump System
- F PSM Control Unit
- G Customer Robot
- H PSM Metering Unit
- J Customer Robot Control Unit
- K Air Line of Supply Pump
- L Material Supply Line
- M Air Line of PSM

- N Servo Motor Encoder Cable
- P Servo Motor Power Cable
- R Junction Box Communication Cable
- S I/O Communication Cable
- ⁽¹⁾ Required, but not supplied

Component Identification

PSM Metering Unit, Supply Pump Feed

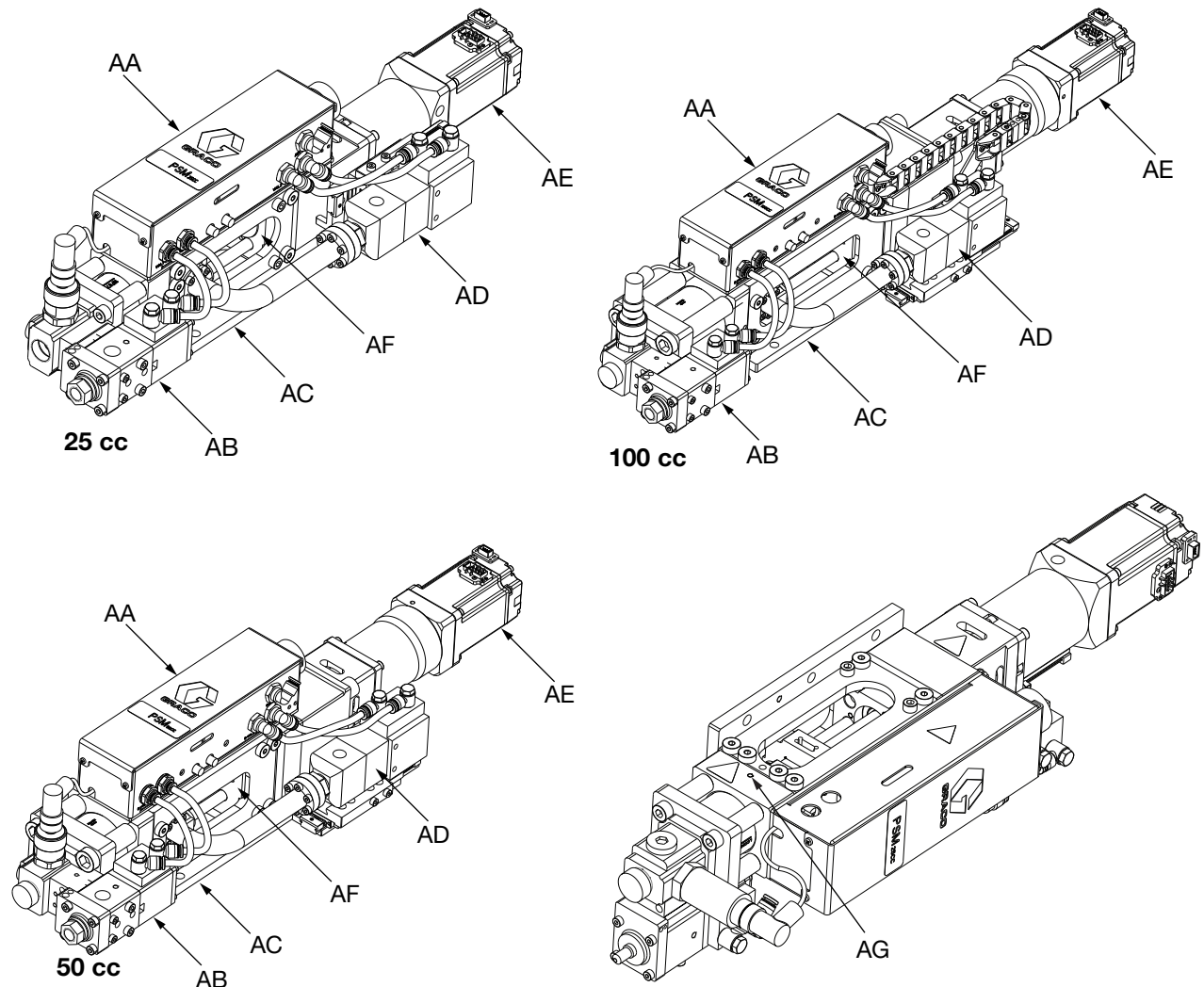

Fig. 2: PSM Metering Unit, Supply Pump Feed

Key:

- AA Junction Box Assembly
- AB Dispense Valve
- AC Installation Plate
- AD Inlet Valve
- AE Drive Assembly
- AF Base Unit
- AG Piston observation hole ⁽¹⁾

⁽¹⁾The sketch takes 25 cc as an example. The piston observation holes for 50 cc and 100 cc are at the same places.

PSM Control Unit

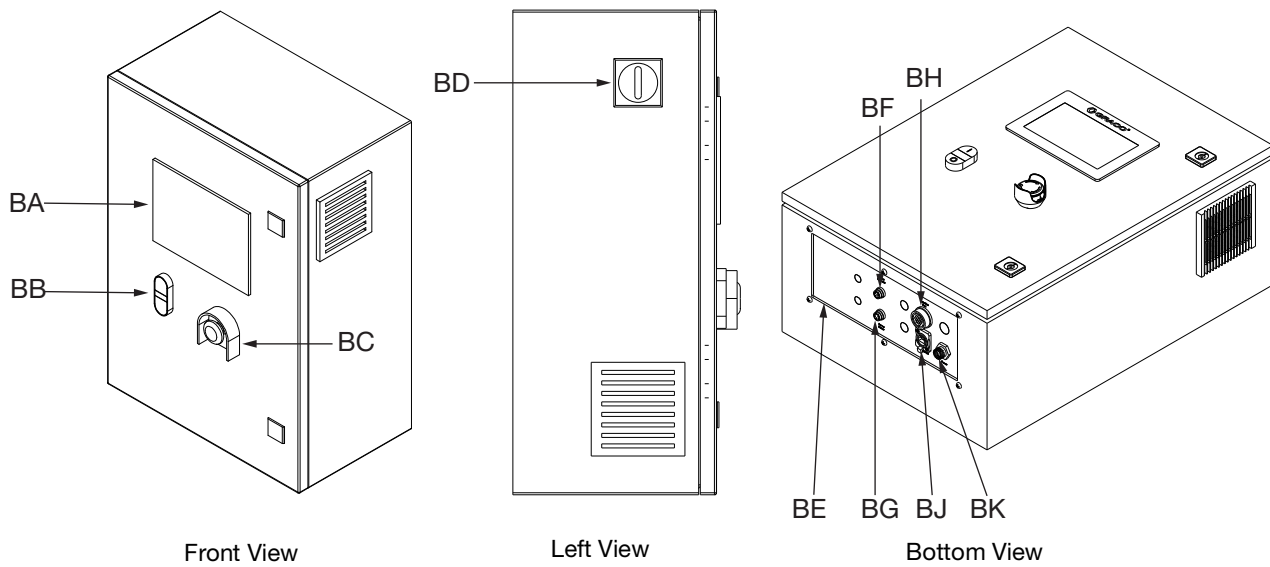

FIG. 3: PSM Control Unit



Key:

- BA Human Machine Interface (HMI) Display
- BB Servo Driver Power On/Off Buttons
- BC Emergency Stop Switch
- BD Main Power Switch
- BE Connection Plate
- BF Servo Motor Encoder Connection
- BG Servo Motor Power Connection
- BH Junction Box Connection
- BJ Ethernet Connection
- BK Power Connection

General Information

FIG. 1, FIG. 2 and FIG. 3 are only a guide for identifying system components and for assisting in installation. Contact your Graco distributor or Graco China Customer Service for assistance in designing a system to suit your specific needs.

Installation

				
All electrical wiring must be done by a qualified electrician and comply with all local codes and regulations.				

Unpacking

1. Inspect the shipping container carefully for damage. Contact the carrier promptly if there is damage.
2. Open the box and inspect the contents carefully. There should not be any loose or damaged parts in the container.
3. Compare the packing slip against all the items in the box. Report any shortage or other inspection problems immediately.
4. Remove the PSM system components from the container.

Locate and Install

1. The PSM Metering Unit (H, page 8) can be directly mounted on a Customer Robot (G, page 8) or remotely mounted on a motion table. Verify the location has access to compressed air and AC power.
2. Place the PSM Metering Unit (H, page 8) onto the designated location.
3. Attach the PSM Installation Plate (AC, page 9) to the selected location by installing fasteners (not provided with the PSM metering Unit) through the four mounting holes. There are also two position pin holes. Refer to FIG. 4, FIG. 5 or FIG. 6 for mounting hole dimensions.
4. For remote installed dispense valve, refer to FIG. 7 for mounting hole dimensions.

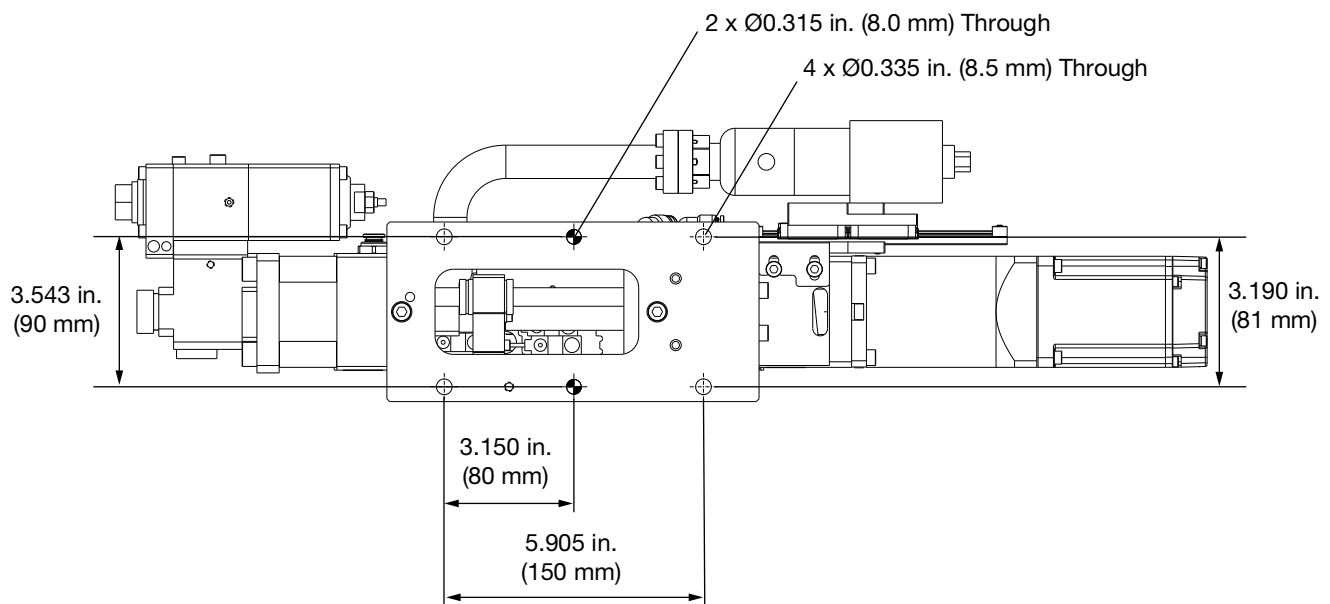

FIG. 4: Mounting Hole Dimensions for Installing the PSM Metering Unit - 25cc

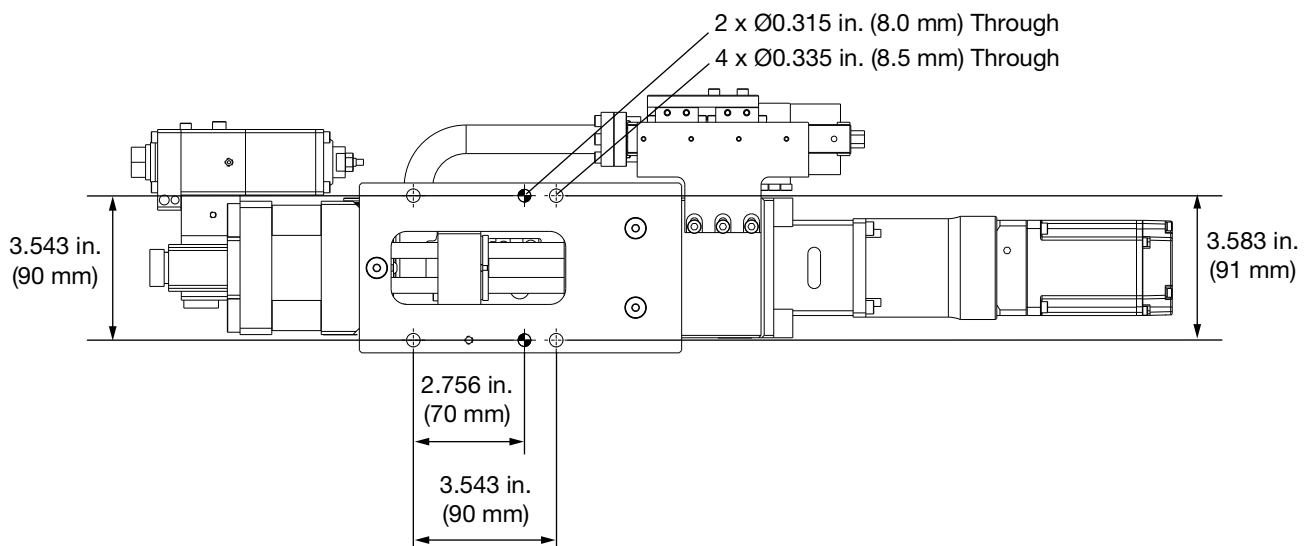

FIG. 5: Mounting Hole Dimensions for Installing the PSM Metering Unit - 50cc

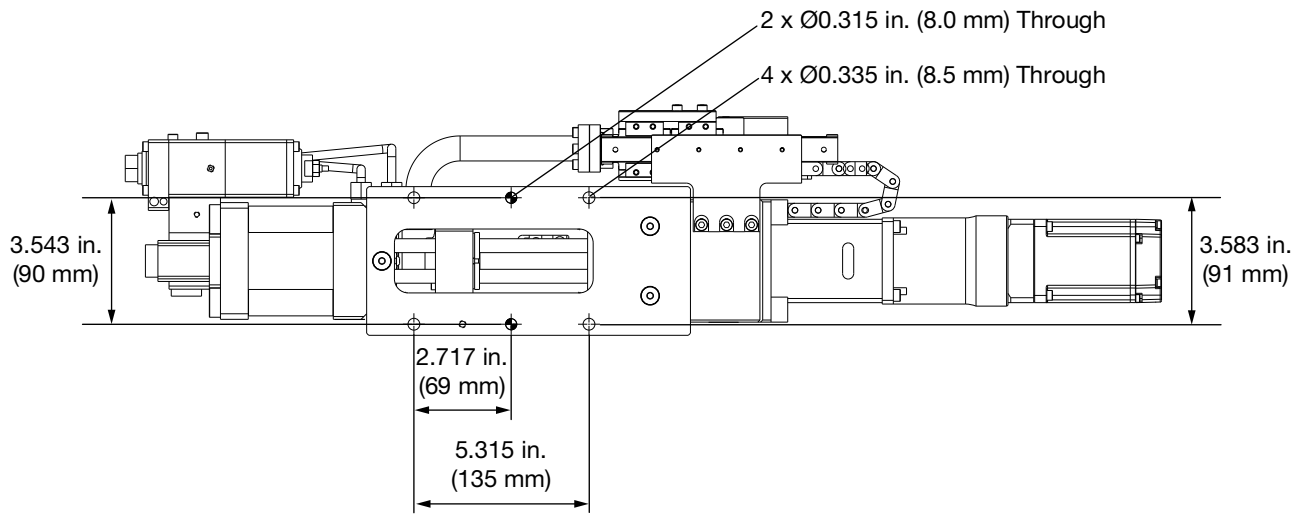

FIG. 6: Mounting Hole Dimensions for Installing the PSM Metering Unit - 100cc

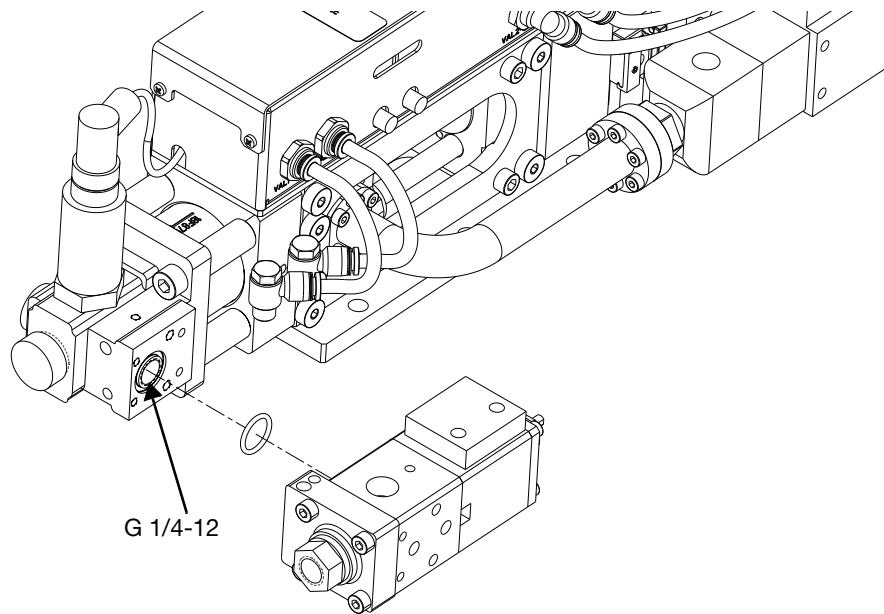



FIG. 7: Mounting Hole Dimensions for Remote Installed Dispense Valve

Grounding



The equipment must be grounded to reduce the risk of static sparking and electric shock. Electric or static sparking can cause fumes to ignite or explode. Improper grounding can cause electric shock. Grounding provides an escape wire for the electric current.

PSM Metering Unit (H, page 8): grounded through the PSM Installation Plate (AC, page 9). Use the supplied ground wire and clamp to ground the metal PSM Installation Plate (AC, page 9) or Customer Robot (G, page 8) to a true earth ground.

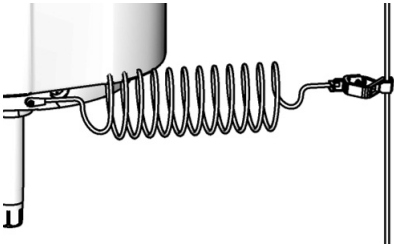

FIG. 8 Grounding

PSM Control Unit (F, page 8): grounded through the power cord.

Air and fluid hoses: use only electrically conductive hoses with a maximum of 500 ft. (150 m) combined hose length to ensure grounding continuity. Check electrical resistance of hoses. If total resistance to ground exceeds 29 megohms, replace hose immediately.

Air compressor: follow manufacturer's recommendations.

Dispense Valve (AB, page 9): ground through connection to a properly grounded fluid hose and pump.

Fluid supply container: follow local code.

Solvent pails used when flushing: follow local code. Use only conductive metal pails, placed on a grounded surface. Do not place the pail on a non-conductive surface, such as paper or cardboard, which interrupts grounding continuity.

Power Requirements

The system requires a dedicated circuit protected with a circuit breaker.

Voltage	Phase	Hz	Current
200-240 VAC	1	50/60	10 A

System Connections



All electrical wiring must be done by a qualified electrician and comply with all local codes and regulations.

This equipment stays pressurized until pressure is manually relieved. To help prevent serious injury from pressurized fluid, such as skin injection and splashing, keep fingers and other body parts away from the spray tip.

To avoid injury from toxic fluids or fumes, such as splashing in the eyes or on skin, wear appropriate personal protective equipment.

1. Connect the PSM System Air Line (M, page 8) to the air inlet of Junction Box Assembly (AA, page 9). The maximum air pressure is 100 psi (0.7 MPa, 7 bar). The air flow is over 1 CFM.
2. Connect the Material Supply Lines (L, page 8) to the corresponding material inlet at the top of Inlet Valve (AD, page 9).
3. Using the power cord provided, connect AC power (220 V, 50/60 Hz, single phase) to the Power Connection (BL, page 10) on the back of PSM Control Unit (F, page 8).
4. Follow the marks on PSM Control Unit (H, page 8) and marks on cables to connect junction box, servo motor power and servo motor encoder from the PSM Metering Unit (H, page 8) to PSM Control Unit (F, page 8).

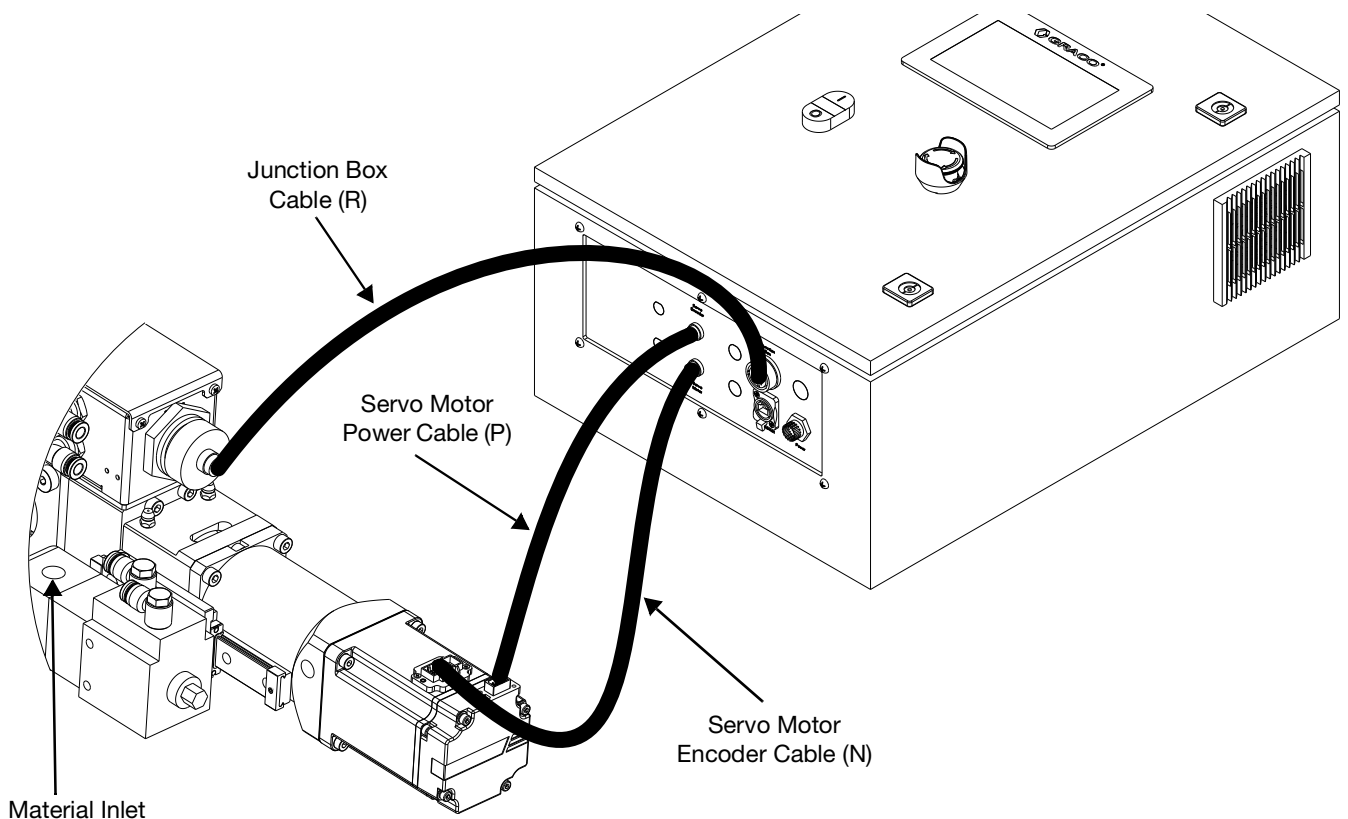



FIG. 9: Cable Connections - Supply Pump Feed Version

Flush Before Using Equipment

The equipment was tested with lightweight oil, which is left in the fluid passages to protect parts. To avoid contaminating your fluid with oil, flush the equipment

with a compatible solvent before using the equipment. Follow **Flush the Equipment** on page 47.

Startup



This equipment stays pressurized until pressure is manually relieved. To help prevent serious injury from pressurized fluid, such as skin injection and splashing, keep fingers and other body parts away from the spray tip.

To avoid injury from toxic fluids or fumes, such as splashing in the eyes or on skin, wear appropriate personal protective equipment.

no leakage at the Dispense Valve (AB, page 9) after shutoff.

NOTE: Very viscous, compressible materials may continue to leak after system is primed. Reduce flow rate as required to produce air-free dispensation. Very thin materials may require tilting the valve greater than 45 degrees and dispensing shots until material is air-free.

NOTE: Air entering the machine should be filtered.

1. Make sure the air line and the cables are correctly connected to the system.
2. Locate the Power Switch (BD, page 10) at the left of the PSM Control Unit (F, page 8) and turn the power on.
3. Press the Control Power on button (BB, page 10).
4. Go to the Advanced Screen of the PSM Control Unit (F, page 8), then select 'Reload valve' to turn on Inlet Valve (AD, page 9).

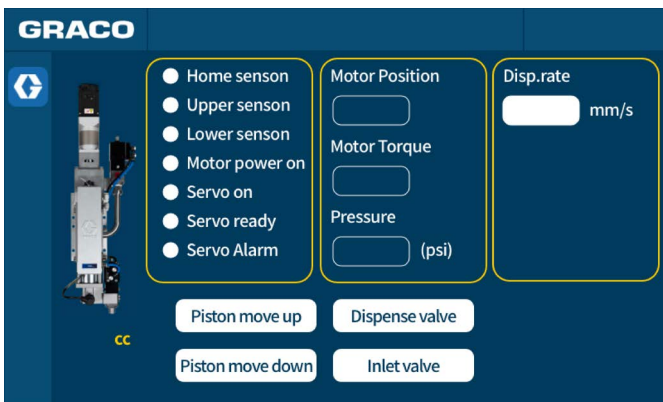

FIG. 10 Advanced Screen

5. Adjust the Pressure Regulating Valve (C, page 8) so the air pressure provided by the customer is at least 80 psi (0.6 MPa, 6 bar), and no higher than 100 psi (0.7 MPa, 7 bar).

NOTE: If needed, add the pressure relief valve to reduce pressure to 100 psi (0.7 MPa, 7 bar).

6. Perform **Prime the System** on page 40.
7. Dispense several full stroke shots until the PSM Metering Unit (H, page 8) is free of air and there is

HMI Display Operation and Identification

Screen Navigation Diagrams

NOTE: The interaction among screens can be achieved by selecting the icons on the screen. The following diagrams take icons as example.

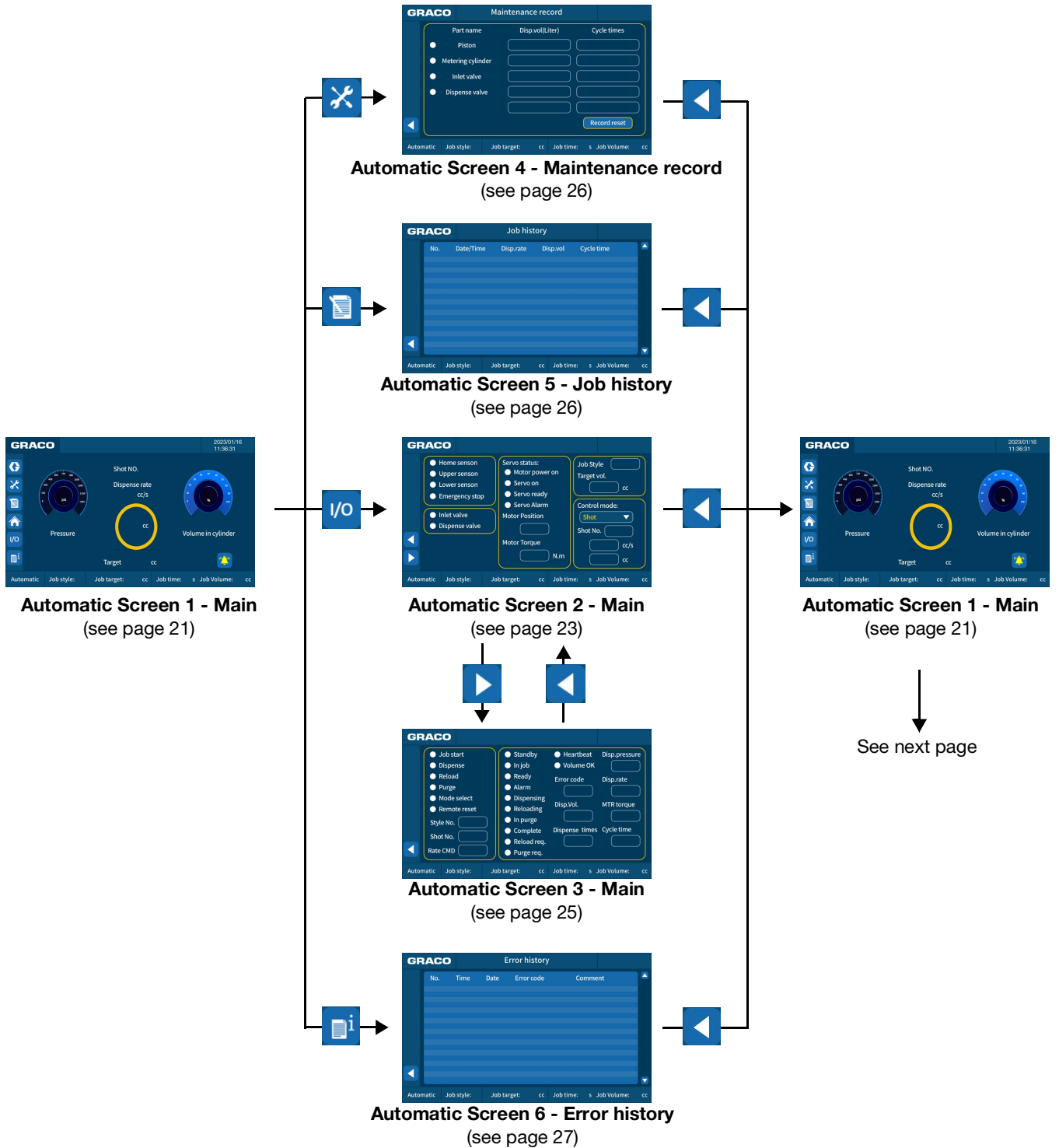

Continued

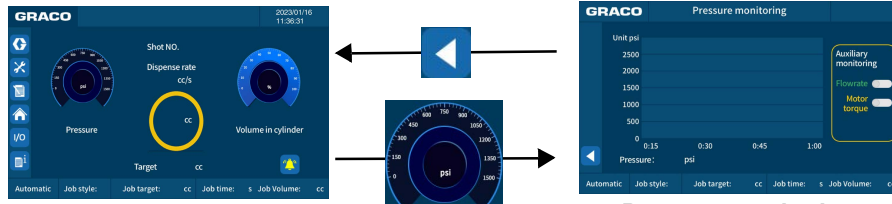

Automatic Screen 1 - Main
(see page 21)

Pressure monitoring
(see page 22)

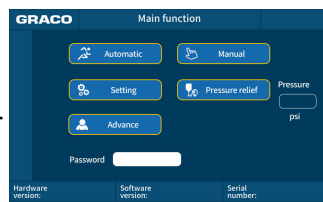
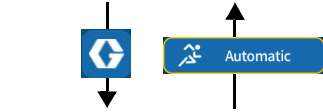

System Main Screen
(see page 27)

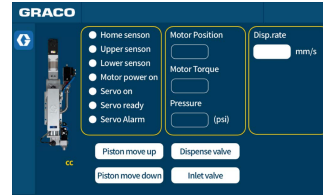

Advanced Screen
(see page 38)

See next page ←

Enter 1492 in 'Password' and select 'Advanced'.

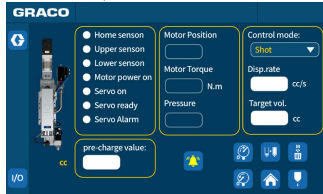
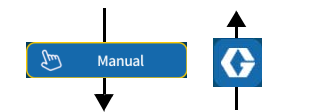

Manual Screen 1
(see page 28)

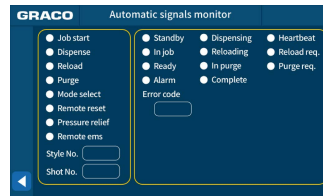
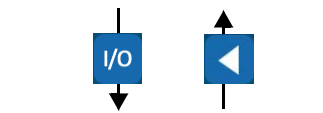

Manual Screen 2
(see page 29)

Continued

NOTE: Click the  button in any screen that has the button can display the System Main Screen, which is not showed in the following diagrams.

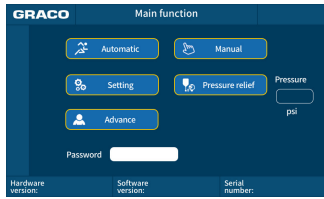

System Main Screen
(see page 27)

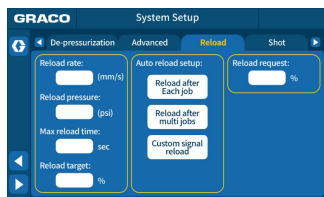

Setup Screen 1 - Reload
(see page 29)

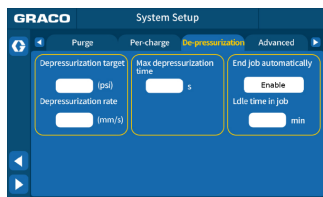

Setup Screen 8 - Depressurize
(see page 35)

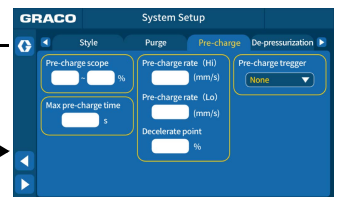

Setup Screen 7 - Pre-charge
(see page 34)

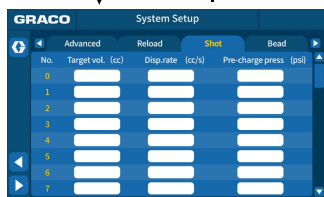

Setup Screen 2 - Shot
(see page 31)

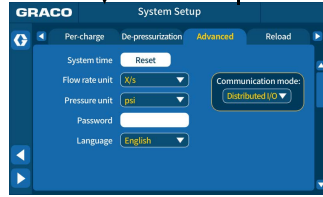

Advanced Setup Screen - 1
(see page 36)

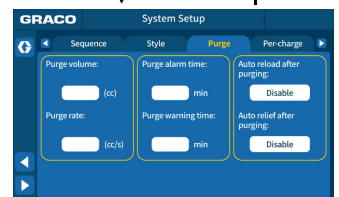

Setup Screen 6 - Purge
(see page 33)

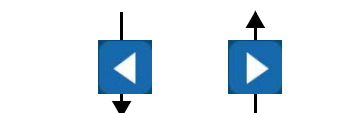
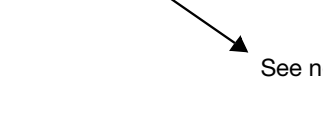
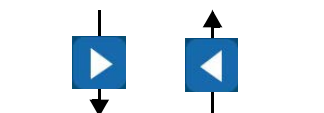

See next page

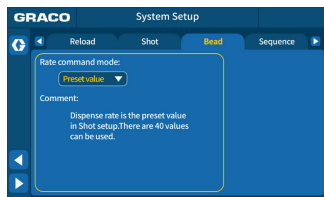

Setup Screen 3 - Bead
(see page 31)

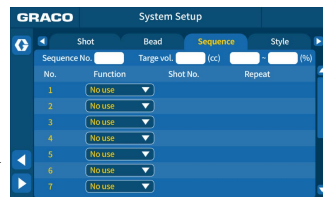

Setup Screen 4 - Sequence
(see page 32)

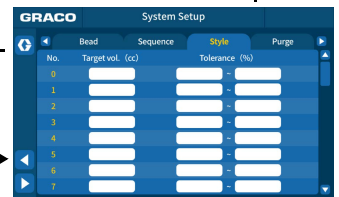

Setup Screen 5 - Style
(see page 32)

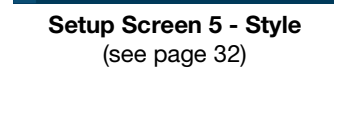
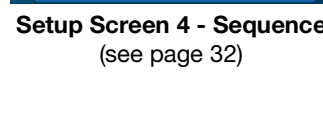
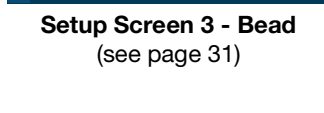

Continued

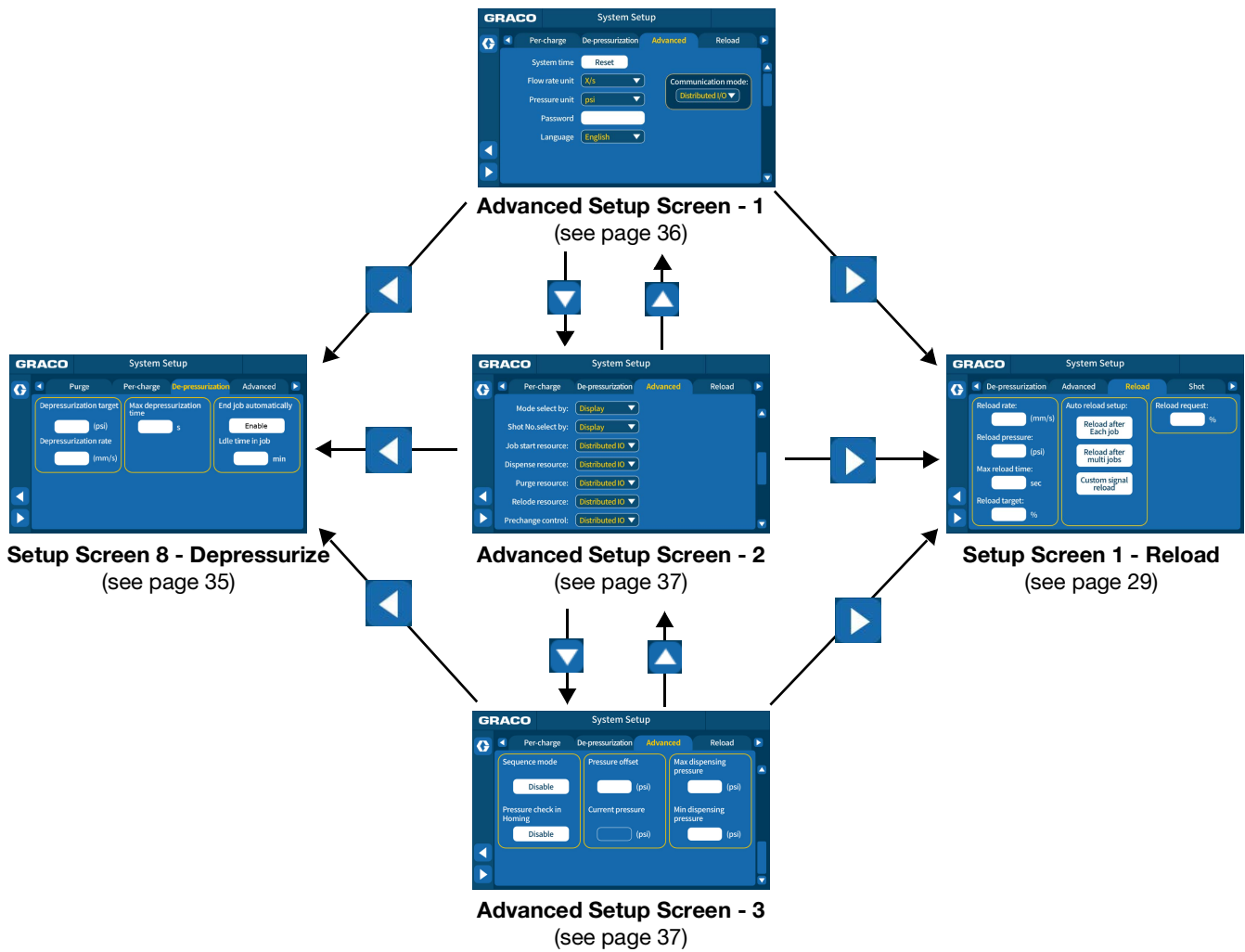







Automatic Screen 1 - Main



FIG. 11 Automatic Screen 1 - Main

Open the PSM control unit and wait for some time. The system will display 'Automatic Screen 1 - Main'.

The content and functions of this screen are as follows:

-  : Select to display the System Main Screen. This button is only available when the system is in standby or has an alarm. When on the System Main Screen, the system will not work in automation mode.
-  : Select to display Automatic Screen 4 - Maintenance record.
-  : Select to execute the command of returning to home point. The system must be inactive when the 'HOME' button is selected. Check in the information bar to see if the piston has returned to the home point.
-  : Select to display Automatic Screen 5 - Job history.
-  : Select to display Automatic Screen 2 - Main.
-  : Select to display Automatic Screen 6 - Error history.

Information bar

Auto_Standby	2023/01/16 11:36:31
--------------	------------------------

- To illustrate the current status of equipment, such as Auto-Standby or Auto-Shot dispense.
- To show error information when an alarm is active.

Status bar

Automatic	Job style:	Job target: cc	Job time: s	Job Volume:
-----------	------------	----------------	-------------	-------------

- Job style:** To show the current style number which defined on **Setup Screen 5 - Style**, see page 32.
- Job target:** To show the target volume which defined on **Setup Screen 5 - Style**, see page 32.
- Job time:** To show the accumulative time of a job.
- Job volume:** To show the accumulative volume of a job.

Pressure monitoring



The current pressure is shown in psi. The operator can change the unit of pressure. See **Pressure unit**, page 36. Click to see working pressure trend.

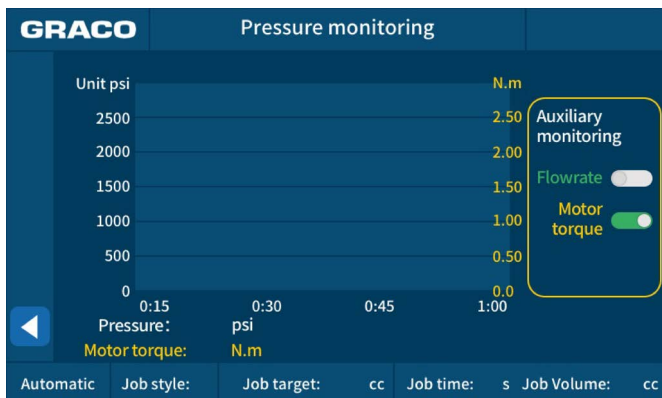
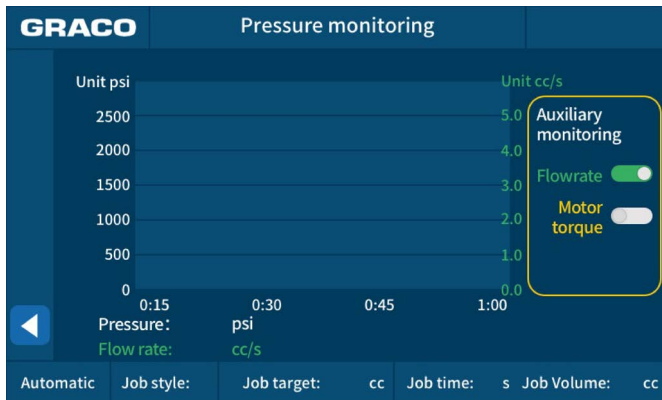
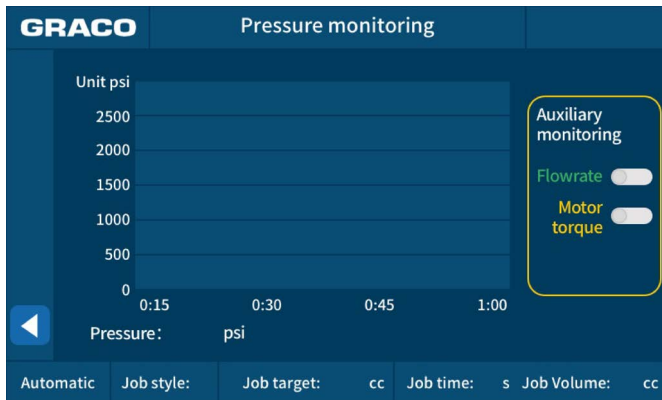

On Pressure Monitoring Screen, select  to display Automatic Screen 1 - Main.

Progress bar and dispense volume



- **Progress bar**
 - Shot mode: The progress bar displays the completion of the current target.
 - Bead mode: The progress bar always displays 100%.
- **Dispense volume:** Display the volume for current one shot.

Volume in cylinder

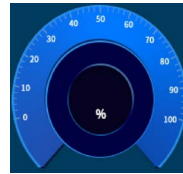

This displays how much material is in the cylinders (0-100%). When the rod slider is at the home position, 'Volume in cylinder' will show 100%. When the slider moves to the 'empty' position, 'Volume in cylinder' will show 0%.

'Reset' button



When the system sends out the alarm, select the button to stop the alarm.

Automatic Screen 2 - Main

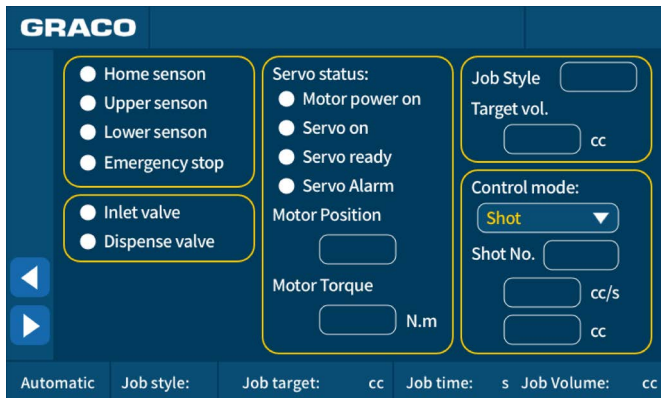

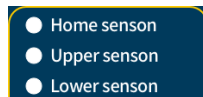

FIG. 12 Automatic Screen 2 - Main

On the Automatic Screen 2 - Main, select the  button to display the Automatic Screen 1 - Main. Select the  button to display the Automatic Screen 3 - Main.

The content and functions of this screen are as follows:

Sensors status



To show the 3 slider position sensors.

Emergency stop status



- **Red circle:** E-stop button is pushed in.
- **Green circle:** E-stop button is released.

Servo motor signals

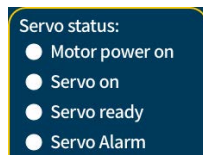

- **Servo ON:** This signal will be shown as green after system start.
- **Servo ready:** Motor can be used or is working without problem.
- **Servo alarm:** Something is wrong with the motor. Operator should push the reset button or send a remote reset signal. If reset does not work, the PSM control unit needs to be restarted.

Reload or dispense valve status

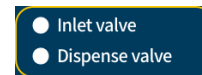

To show if the reloading valve or dispensing valve is open.

Motor position and torque

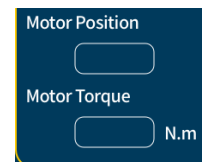

To Show the number of motor steps. The torque of the drive motor is shown in N•m. The motor torque range is 0-1.27 N•m. The motor position range of PSM25, PSM50 and PSM100 are 0-140000, 0-180000 and 0-348000 respectively.

Job style and target volume

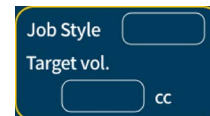

To show the current style number and target volume which defined on **Setup Screen 5 - Style**, see page 32.

Control mode

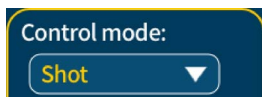

Automatic mode includes three control modes: shot mode, bead mode and sequence mode.

- **Shot mode:** Per the style selected, the system will dispense at the preset volume and flow rate. For the preset style, see **Setup Screen 2 - Shot**, page 31.
- **Bead mode:** Per the style selected, the system will dispense at the preset flow rate. For the preset style, see **Setup Screen 3 - Bead**, page 31.
- **Sequence mode:** When the system works in automatic status, the Customer Robot Control Unit (J) can send 'dispense' signal to initiate the sequence. The working sequence can only be edited before dispense starts. The sequence includes 14 steps maximum.
 - When 'Enable Sequence Mode' option is not selected and the system is not dispensing, the operator may choose between 'Bead' or 'Shot' mode by using the touch screen or customer signal.
 - When 'Enable Sequence Mode' option is selected, control mode will be fixed as 'Sequence' mode. 'Bead' or 'Shot' mode will be inaccessible.

NOTE: For enabling sequence mode, see 'Enabling sequence mode' in **Advanced Setup Screen - 2**, page 37. For preset sequence style, see **Setup Screen 4 - Sequence**, page 32.

System working information

This area shows information unique to each control mode.

- Shot mode



In Shot mode, the selected style number, target flow rate and target volume will be shown. Shot style can be selected by touch screen or customer signals. Preset styles include 40 styles, 0-39.

- Bead mode with preset value



In Bead mode with preset value, the selected style number and target flow rate will be shown. The process for style number selection is the same as Shot mode.

- Bead mode with custom setting

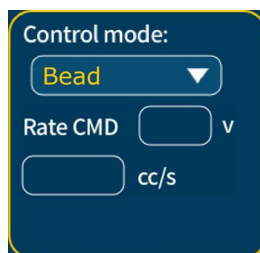

In Bead mode with custom setting, Rate command (Rate CMD) will be shown as voltage value and target flow rate will be shown. The flow rate will change based on rate command.

- Sequence mode

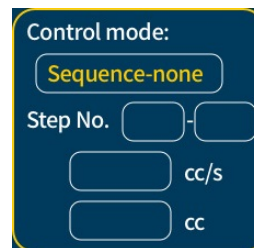
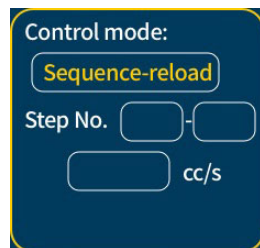
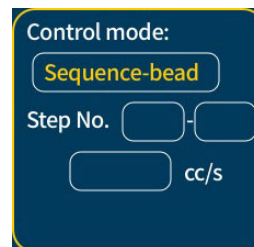
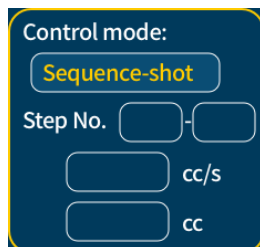

In Sequence mode, the step number, remaining repeat times, target flow rate and volume will be shown in different screens based on different step types. The operator can edit the step by using the touch screen prior to or following the current job. Once dispensing has begun, the 'Control mode' display will show the current step, including sequence shot, sequence bead sequence reload and sequence none.

Automatic Screen 3 - Main

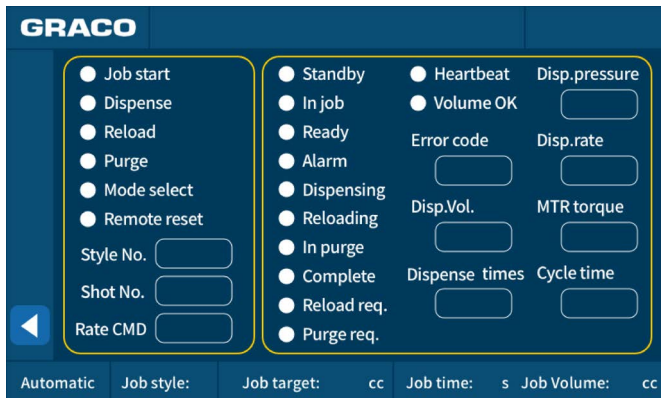

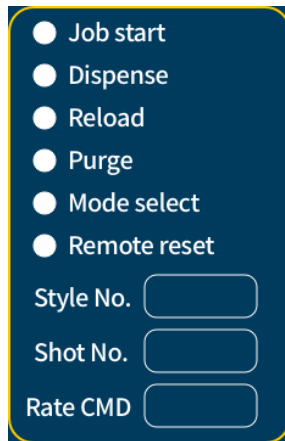

FIG. 13 Automatic Screen 3 - Main

On the Automatic Screen 3 - Main, select the  button to display the Automatic Screen 1 - Main.

The content and functions of this screen are as follows:

Input signals status



The input signals display shows the current signal status from customer inputs.

- Rate CMD
 - If 'distributed IO' is selected on **Advanced Setup Screen - 2**, see page 37, the input voltage signal will be shown as 0-10.0, where 0 means 0 voltage, 10.0 means 10 V.
 - If 'Gateway' is selected on **Advanced Setup Screen - 2**, see page 37, the input data sent by Profinet will be shown as a value from 0 to 1000.

Output signals status

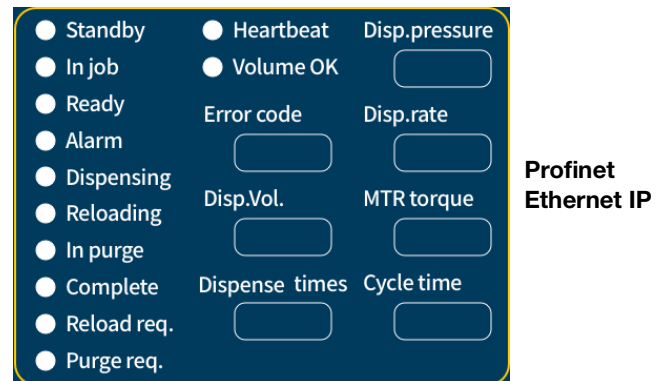
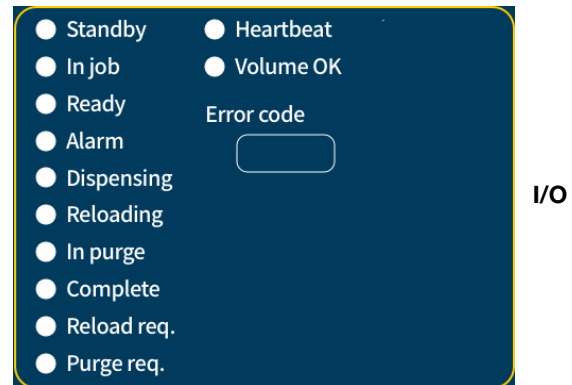

The output signals display shows the current signal status from the PSM control unit.

- **Standby:** The system has checked the home position, but is not pre-charged.
- **In job:** The job starts from pressure pre-charge and ends after pressure relief. The system will record the dispense volume for each job. In shot or bead mode, 'job start' signal must be '1' during one job. In sequence mode, step 0 to step 15 will be considered one job.
- **Ready:** Pre-charge has been completed and the system is ready to dispense material.
- **Dispensing:** The system is dispensing material.
- **Reloading:** The system is reloading material.
- **In purge:** The system is purging some material based on the preset flow rate and volume.
- **Error code:** For error code information, see **Appendix A - PSM Error Codes**, page 57.

Automatic Screen 4 - Maintenance record

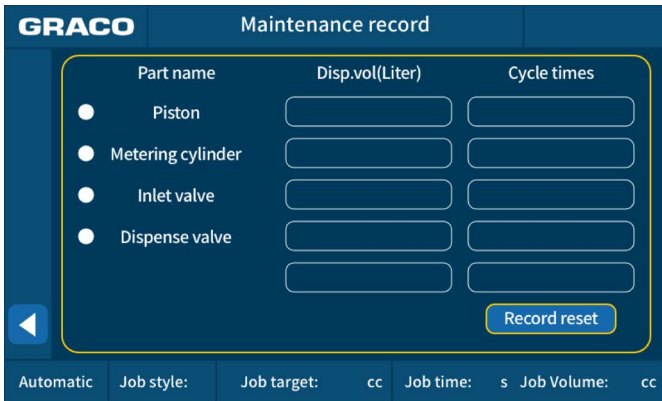



FIG. 14 Automatic Screen 4 - Maintenance record

On the Automatic Screen 4 - Maintenance record, select the  button to display the Automatic Screen 1 - Main.

The content and functions of this screen are as follows:

Select box



After one or several selection boxes are selected, the 'Record reset' button will appear. The operator can clear the selected record and restart data recording.

Workload record

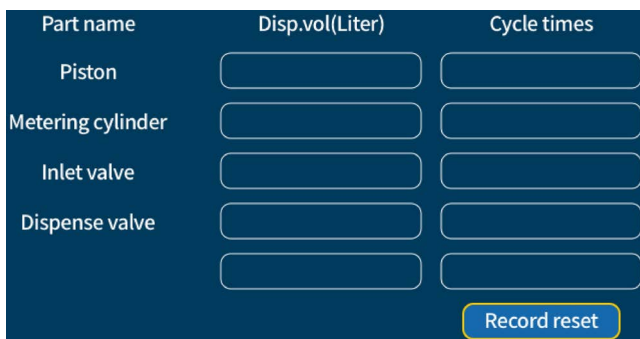

To record the workload of important parts. Click the 'Record reset' button to reset the data. The last section box records the statistics workload. This data cannot be reset.

Automatic Screen 5 - Job history

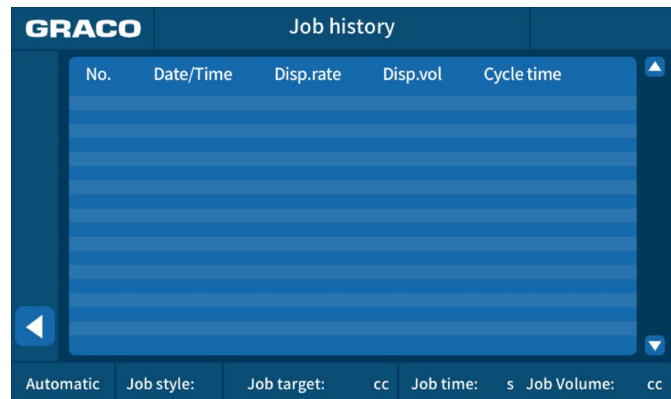



FIG. 15 Automatic Screen 5 - Job history

On the Automatic Screen 4 - Maintenance record, select the  button to display the Automatic Screen 1 - Main.

This screen shows the job history. It will record the shot number, date and time, dispense rate, dispense volume and cycle time for the last 50 job records.

Automatic Screen 6 - Error history

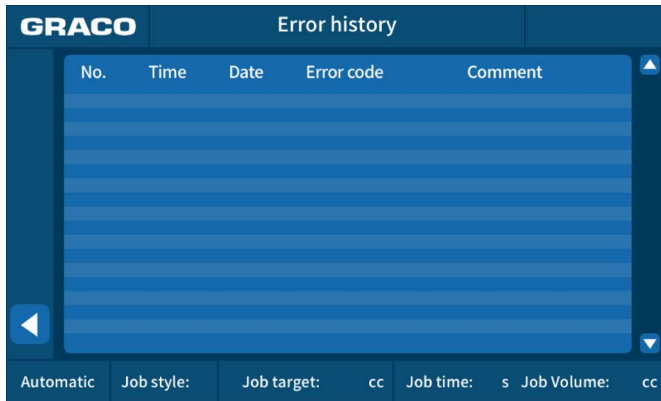



FIG. 16 Automatic Screen 6 - Error history

On the Automatic Screen 6 - Error history, select the  button to display the Automatic Screen 1 - Main. This screen shows the error history. It will record the error number, time, date, error code and comment for the last 50 system errors.

System Main Screen

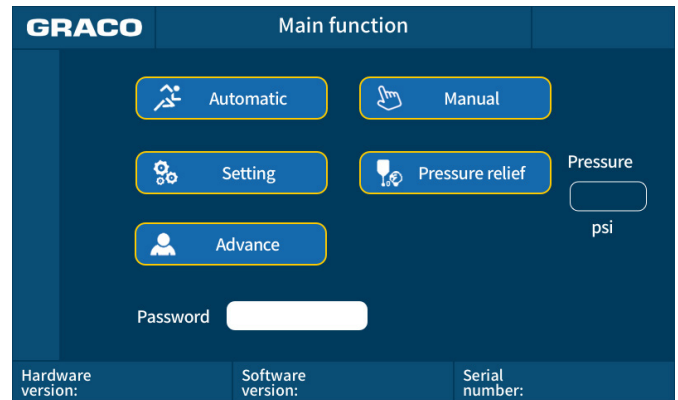



FIG. 17 System Main Screen

On the Automatic Screen 1 - Main, press  button to display the System Main Screen. This button can only be selected when the system is in standby or alarm mode. On this screen, the operator can switch the system to Automatic mode, Manual mode, Setting mode, Pressure relief function or Advance mode.

If the operator has already set up password protection on **Advanced Setup Screen - 1**, see page 36, the password must be entered to visit the Setup Screens.

To open the Advance mode, the operator must enter the password **1492**. The Advanced option won't show until the password has been entered.

Select 'Pressure relief' button to execute pressure relief procedure. For more information, see **Pressure Relief Procedure**, page 47.

System information



System main screen displays system information.

Manual Screen 1

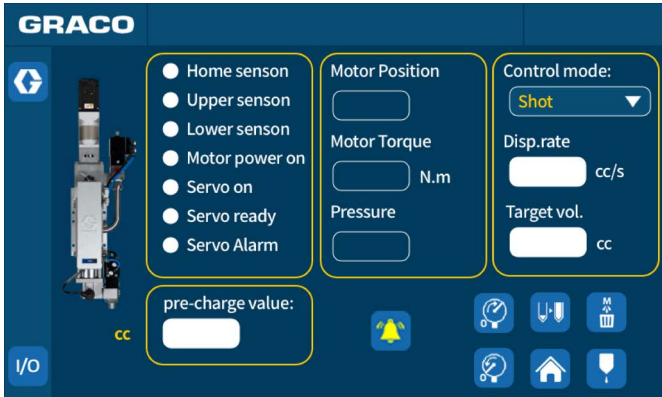











FIG. 18 Manual Screen 1

On the Manual Screen 1, Press 'F1' or select the  button to display the System Main Screen. This button can only be selected when the system is in standby or alarm mode. When the operator has entered the System Main Screen, the system will not work in Automation mode. Select the  button to display the Manual Screen 2.

The content and functions of this screen are as follows:

-  : Select to execute the command of returning to home point. The system must be inactive when the 'HOME' button is selected. Check in the information bar to see if the piston has returned to the home point.
-  : When the piston returns to home point, the system displays 'Reload' button. Select the button to reload material.
-  : Select the button to execute pre-charge.
-  : Select the button to execute pressure relief.
-  : Select the button to execute purging.
-  : When the system sends out the alarm, select the button to stop the alarm.
-  : Select the button to dispense material.

Other information

Parameter	PSM25 Range	PSM50 Range	PSM100 Range
Motor Position	0-140000	0-180000	0-348000
Motor Torque (N•m)	0-1.27	0-1.27	0-1.27
Pressure (psi)	0-1200	0-3000	0-3000
Disp. rate (cc/s)	0.010-9.6	0.015-15	0.015-15
Target vol. (cc)	0-25	0-50	0-100

For other information, please see **Automatic Screen 2 - Main** on page 23.

Manual Screen 2

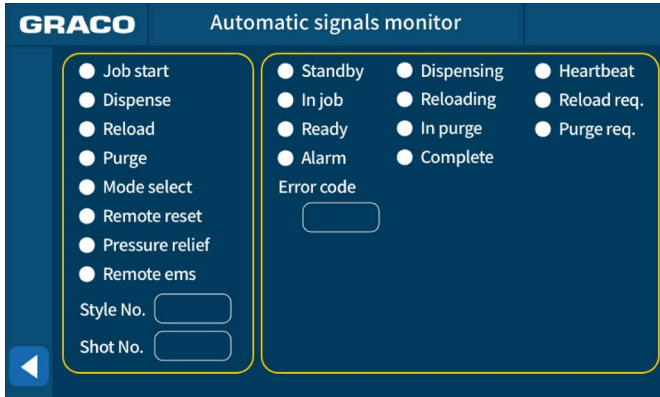



FIG. 19 Manual Screen 2

On the Manual Screen 2, select the  button to display the Manual Screen 1.

The Manual Screen 2 is to check the signal exchange.

For error code information, see **Appendix A - PSM Error Codes**, page 57.

Setup Screen

Setup Screen 1 - Reload

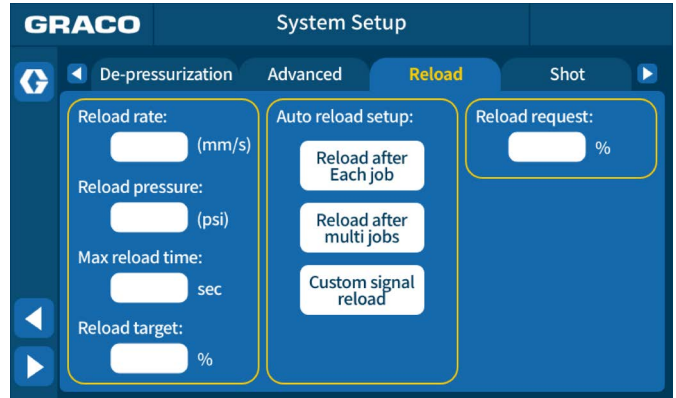



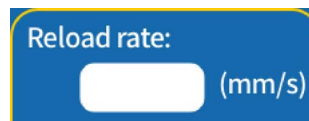

FIG. 20 Reload Setup Screen

On the Reload Setup Screen, select the  button to display the System Main Screen. Select the  button to return to the previous screen. Select the  button to continue to the next screen.

The content and functions of this screen are as follows:

Reload rate setup



Set both the reloading speed and 'Home' operations speed. The reload rate range of PSM25, PSM50 and PSM100 are 0.012-12.5 mm/s, 0.008 - 8.333 mm/s and 0.008 - 8.333 mm/s respectively.

Reload pressure setup

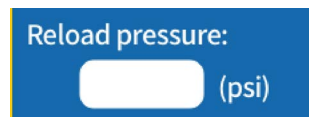

Set the reload pressure. During reloading, after piston returns to home position, the system will keep the Inlet Valve (AD) open until the pressure has exceeded the preset reload pressure. The reload pressure range is 0 to the max. dispensing pressure which is set on **Advanced Setup Screen - 3**, page 37.

Maximum reload time

A blue rectangular HMI input field with rounded corners. The text "Max reload time:" is at the top left. Below it is a white rounded rectangular input box, followed by the text "sec" on the right.

Set reload time limit. If the reload process exceeds the time limit, the system will send out an alarm as a reload time out.

Reload target setup

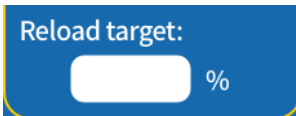
A blue rectangular HMI input field with rounded corners. The text "Reload target:" is at the top left. Below it is a white rounded rectangular input box, followed by the text "%" on the right.

Set the target completed position of reload. For example, if 80% is set to be the reload target, the system finishes reloading when it is 80% full of the reload volume. The operator can set a range from 80% to 100% and should adjust the value per material viscosity and fluid pressure.

Reload type setup

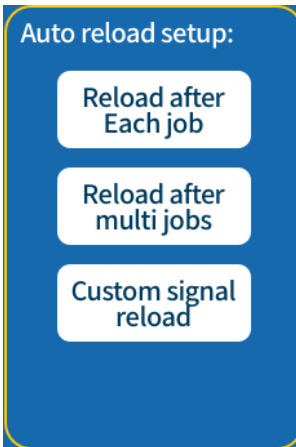
A blue rectangular HMI selection screen with rounded corners. The text "Auto reload setup:" is at the top left. Below it are three white rounded rectangular buttons stacked vertically, each containing text: "Reload after Each job", "Reload after multi jobs", and "Custom signal reload".

- *Reload after each job*: In this mode, the metering rod retracts after every job. This is the default setup.
- *Reload after multi jobs*: In this mode, the metering rod retracts only when the job is completed and the metering rod reaches the reload request position.
- *Custom signal reload*: In this mode, the metering rod retracts only when the operator sends 'Reload' signal. When in job status, the system automatically executes pre-charge after reloading.

Reload request position

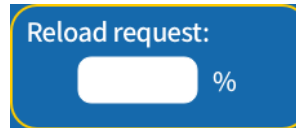
A blue rectangular HMI input field with rounded corners. The text "Reload request:" is at the top left. Below it is a white rounded rectangular input box, followed by the text "%" on the right.

- When the material in the supply pump system is less than the percentage set here, the system will send out an alarm, but the system can still work.
- If Reload after each job or Reload after multi jobs is selected, and the material in the supply pump system or supply cartridge is less than the percentage set here, the system automatically reloads after each job or multiple jobs.

Setup Screen 2 - Shot

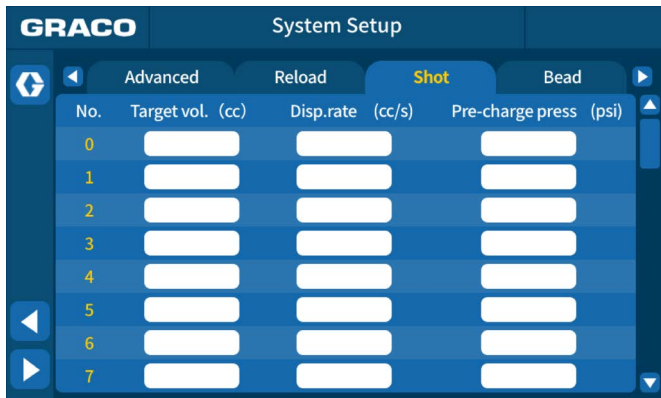





FIG. 21 Shot Setup Screen

On the Shot Setup Screen, select the  button to display the System Main Screen. Select the  button to return to the previous screen. Select the  button to continue to the next screen.

This screen includes 5 pages of 40 shot numbers to set target volume, dispense rate and pre-charge pressure.

Setup Screen 3 - Bead

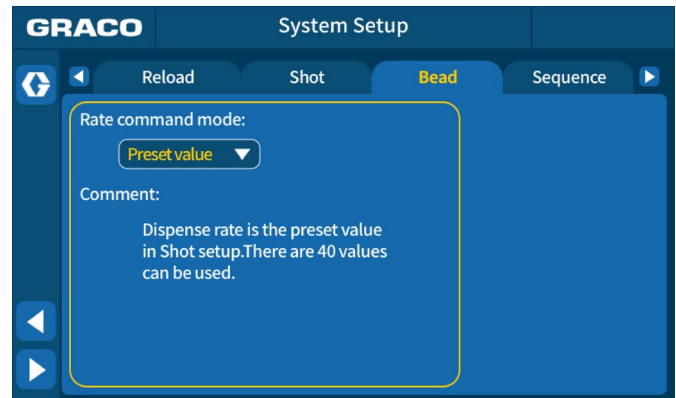

FIG. 22 Bead Setup Screen (Preset value)

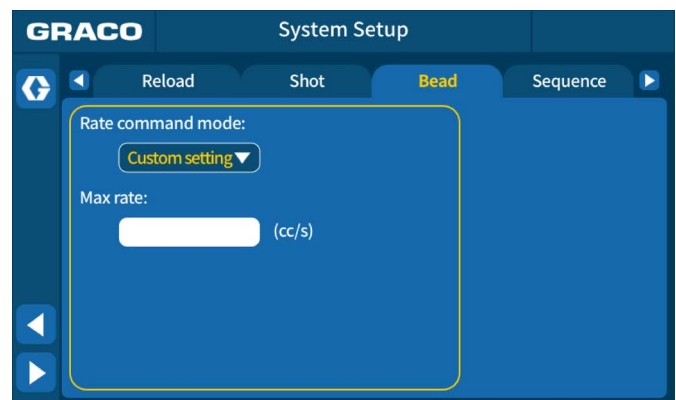





FIG. 23 Bead Setup Screen (Custom setting)

On the Bead Setup Screen, select the  button to display the System Main Screen. Select the  button to return to the previous screen. Select the  button to continue to the next screen.

There are two Rate command types:

- **Preset value:** The flow rate is defined on **Setup Screen 2 - Shot**, see page 31. 'Shot bit 0-3' signals or style numbers are used to select flow rate.
- **Custom setting:** The operator should set 'Max Rate' first. The Operator can use 0-10 V signal to control flow rate.

Setup Screen 4 - Sequence

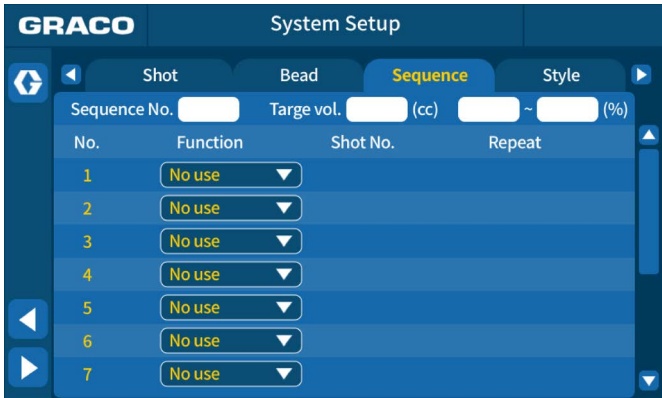





FIG. 24 Sequence Setup Screen

On the Sequence Setup Screen, select the  button to display the System Main Screen. Select the  button to return to the previous screen. Select the  button to continue to the next screen.

Sequence includes 16 steps maximum. Operator can select functions including shot, bead, reload and not used. If the shot or bead function is selected, repeat time can be set (1-99).

Setup Screen 5 - Style

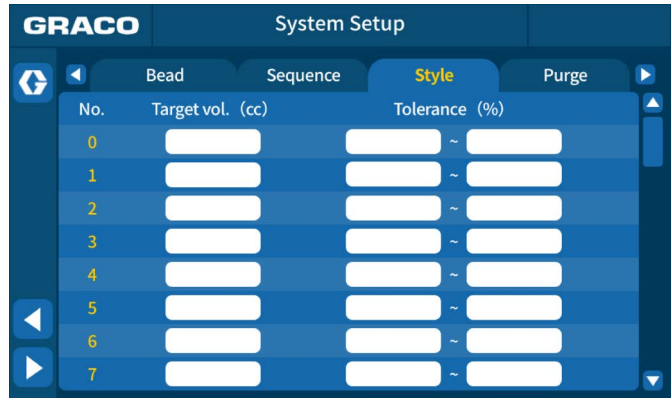





FIG. 25 Style Setup Screen

On the Style Setup Screen, select the  button to display the System Main Screen. Select the  button to return to the previous screen. Select the  button to continue to the next screen.

This screen includes 5 pages of 40 style numbers to set target volume and tolerance. After each job, the system compares the dispense volume and the target volume. If the deviation is out of the tolerance, the system will send out the signal.

Setup Screen 6 - Purge

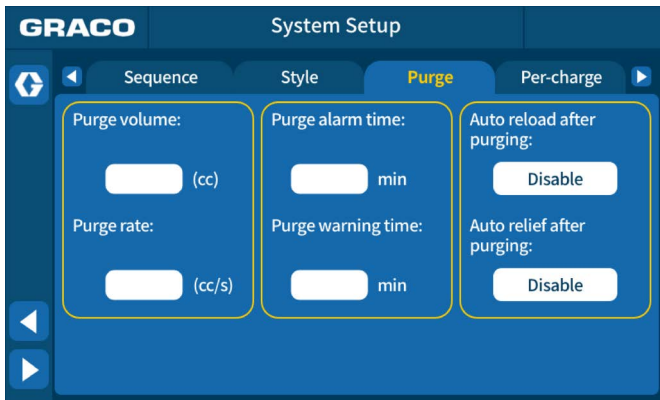



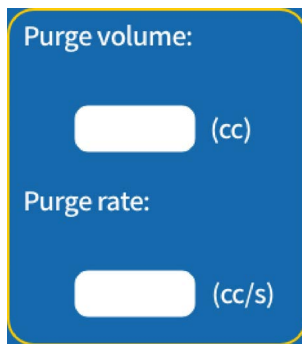

FIG. 26 Purge Setup Screen

On the Purge Setup Screen, select the  button to display the System Main Screen. Select the  button to return to the previous screen. Select the  button to continue to the next screen.

The content and functions of this screen are as follows:

Purge volume and rate setup



- *Purge volume*: Set the target purge volume.
- *Purge rate*: Set the purge flowrate.

Purge alarm time

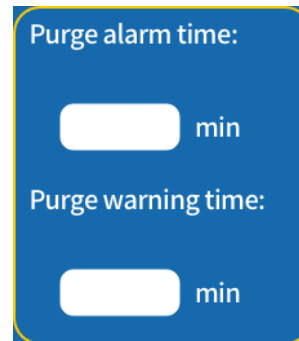

Set the purge request time. When the equipment doesn't dispense, the PSM control unit will start the countdown for the time chosen by the operator. When time is up, the system will send out the purge alarm signal and show 'purge request' in the information bar.

Purge type setup

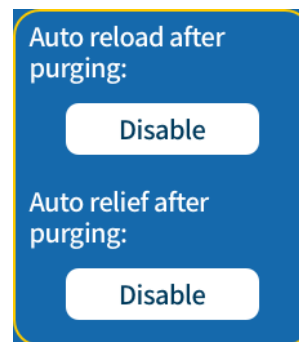

- *Auto reload after purge button*: When enabled, the system automatically reloads after purge is completed.
- *Auto relief after purge button*: When enabled, the system automatically performs pressure relief after purge is completed.

Setup Screen 7 - Pre-charge

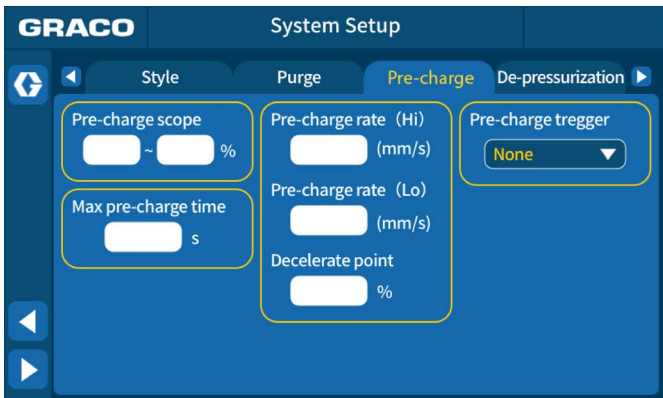





FIG. 27 Pre-charge Setup Screen

On the Pre-charge Setup Screen, select the  button to display the System Main Screen. Select the  button to return to the previous screen. Select the  button to continue to the next screen.

The content and functions of this screen are as follows:

Pre-charge pressure scope



The pre-charge pressure value is set in **Setup Screen 7 - Pre-charge**, page 34. The operator may set a scope of pre-charge pressure. The system starts to work when reaching the scope of pre-charge pressure.

Maximum pre-charge time limit

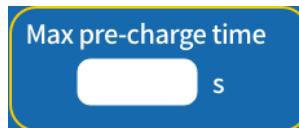

The operator may set the time in seconds the system may spend pre-charging. If pre-charging exceeds the set time, the system will activate the alarm to alert the operator the limit has been reached.

Pre-charge speed

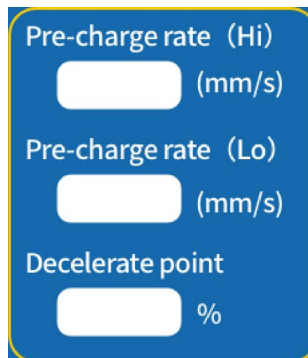

The operator may set two separate pre-charge rates. The system will pre-charge at the set 'Hi' speed until reaching the decelerate point. The decelerate point is the target pressure at which the system will switch from the "Hi" to the "Lo" pre-charge rate. Enter the decelerate point as a percentage of the Pre-charge pressure. For example, if the pre-charge pressure is 500 psi and the decelerate point is 75%, the system will switch to the 'Lo' speed once pressure has reached 375 psi. The system will then continue pre-charging at the set 'Lo' speed until system confirms the pressure has exceeded the set target pressure.

Pre-charge trigger

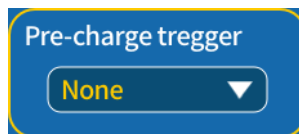

The operator may choose whether the pre-charge is needed.

Setup Screen 8 - Depressurize

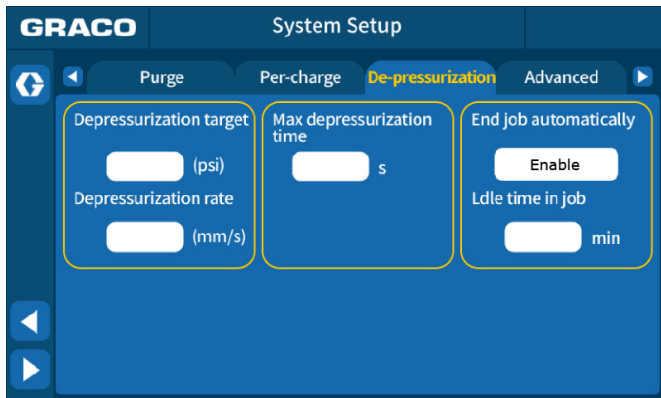





FIG. 28 De-pressurization Setup Screen

On the De-pressurization Setup Screen, select the  button to display the System Main Screen. Select the  button to return to the previous screen. Select the  button to continue to the next screen.

The content and functions of this screen are as follows:

De-pressurization setup



- *Depressurization target*: The operator may set the depressurization target. The system will reduce the pressure to the target volume automatically when the job is finished.

NOTE: Set different depressurization targets according to different materials. For detailed information, please contact your Graco distributor.

- *Max depressurization time*: The operator may set a maximum time in seconds for the system to perform depressurization. If depressurization function exceeds the set time, the system alarm will be activated.
- *Depressurization rate*: The operator may input a value here to set the piston speed during depressurization.

End job automatically

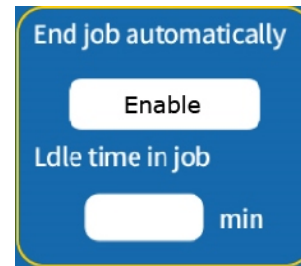

After this option is enabled, the operator must set the maximum idle time for the system while performing a job. After the set period passes without any operation, the depressurization program will be automatically executed and the current job ended.

Advanced Setup Screen

Advanced Setup Screen - 1

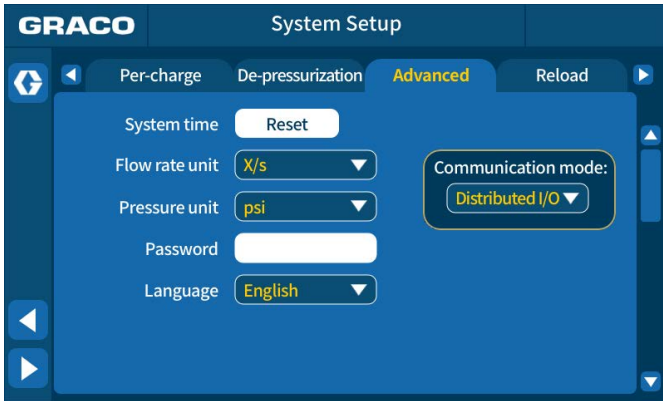





FIG. 29 Advanced Setup Screen - 1

On the Advanced Setup Screen1, select the  button to display the Advanced Setup Screen 2. Select the  button to display the System Main Screen. Select the  button to return to the previous screen. Select the  button to continue to the next screen.

The content and functions of this screen are as follows:

System time

Select the 'Reset' button, set system time by using the popup keyboard.

Flowrate unit

The operator may select either cc/minute or cc/second from the dropdown list to customize the units used for flowrate setup.

Pressure unit

The operator may select psi, bar or MPa from the dropdown list to customize the units used for pressure setup.

Password

If this function is selected, a 4-digit number should be set. After the 4-digit number is set, the operator must be prompted to input the password before navigating to any of the setup screens.

Language

The operator may select either Chinese (by selecting the Chinese flag) or English (by selecting British flag) to change the language used on the system's user interface.

Communication mode

The operator may select either Distributed I/O or Gateway (Profinet) from the dropdown list. The default setting is Distributed I/O. If you need to change this setting, you need to make changes and return to System Main Screen. A power-off and restart is required for the changes to take effect.

Advanced Setup Screen - 2

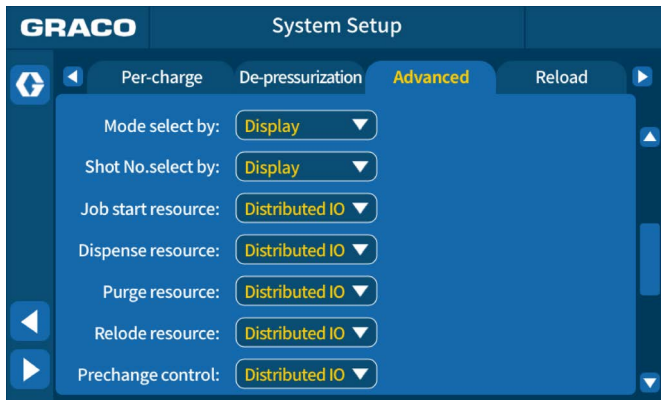





FIG. 30 Advanced Setup Screen - 2

On the Advanced Setup Screen 2, select the  button to display the Advanced Setup Screen 3. Select the  button to display the System Main Screen. Select the  button to return to the previous screen. Select the  button to continue to the next screen.

The content and functions of this screen are as follows:

Mode selected by

Options for mode selection input include Display, Distributed IO or Gateway.

- If 'Distributed IO' or 'Gateway' is selected, in Automatic mode, the shot or bead working mode (Sequence mode will be inaccessible) must be controlled by customer signals. The operator will not be able to change working mode using the touch screen.
- If 'Display' is selected, working mode will include Shot, Bead and Sequence mode. The operator will be able to change working mode using the touch screen.

Shot No. selected by

The operator may choose whether the style number may be changed by Display, Distributed IO or Gateway.

Job start resource, Dispense resource, Purge resource, Reload resource and Precharge control

The operator may choose whether these resources come from Distributed I/O communication or Gateway (Profinet) communication. Display option is unavailable.

Advanced Setup Screen - 3

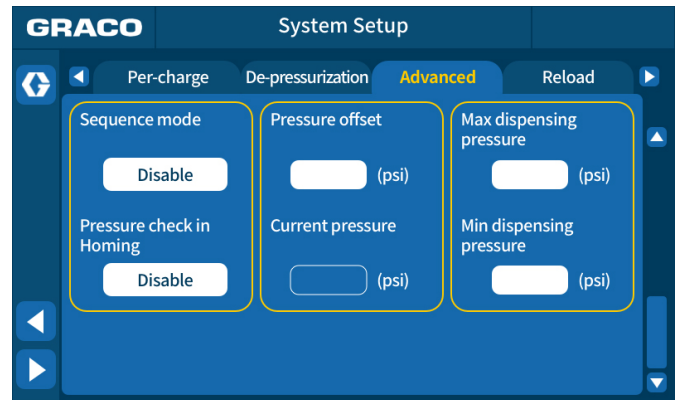



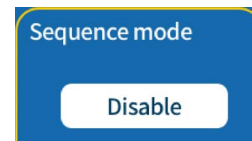

FIG. 31 Advanced Setup Screen - 3

On the Advanced Setup Screen 3, select the  button to display the Advanced Setup Screen 2. Select the  button to display the System Main Screen. Select the  button to return to the previous screen. Select the  button to continue to the next screen.

The content and functions of this screen are as follows:

Sequence mode



Press the button to enable or disable this function. The green color of the button indicates the sequence mode is enabled.

If this function is enabled, the PSM system will run in sequence mode. In this mode, the operator can edit the working sequence (The sequence includes 16 steps maximum. The operator can edit step 1 to 14, as step 0 and 15 are tied to pre-charge and de-pressurization). When the system works in automatic status, the Customer Robot Control Unit (J) can send 'dispense' signal to start the sequence mode and then dispense step by step.

Pressure check in homing

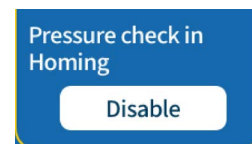

Press the button to enable or disable this function. The green color of the button indicates pressure check after homing is enabled.

If this function is selected, the system pressure will be checked when the piston is at the home position.

Pressure sensor offset

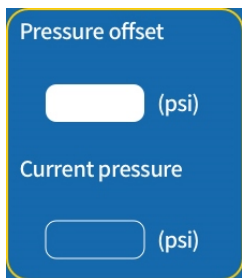

The operator may input values to adjust the pressure offset on the sensors. The pressure offset range is -100 - 100 psi

Pressure limit

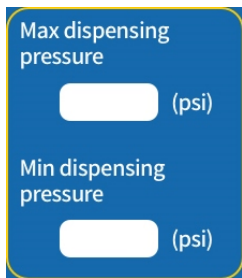

If the pressure is higher than the preset max pressure, the system will activate the alarm and send the alarm signal to customer system.

Advanced Screen

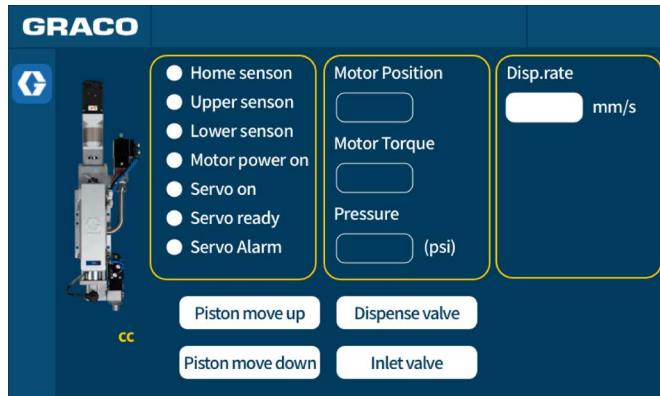

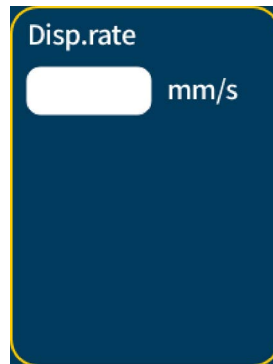

FIG. 32 Advanced Screen

On the Advanced Screen, select the  button to display the System Main Screen. Advanced screen is dedicated to repairing and testing the system. After navigating to this screen, the logic relationship between the drive motor, reloading valves and dispense valves will be overrode and the operator may control each part individually. For this reason, only qualified personnel who have received equipment maintenance training should be authorized to navigate to this screen and perform system check.

The content and functions of this screen are as follows:

Dispense rate



Click at the column to set the speed of the slide block.

Piston move up



This button is for motor, push block and piston tests. Jog control pistons and slide block move away from the outlet port.

Piston move down

Piston move down

Jog control pistons and push block move toward the outlet port.

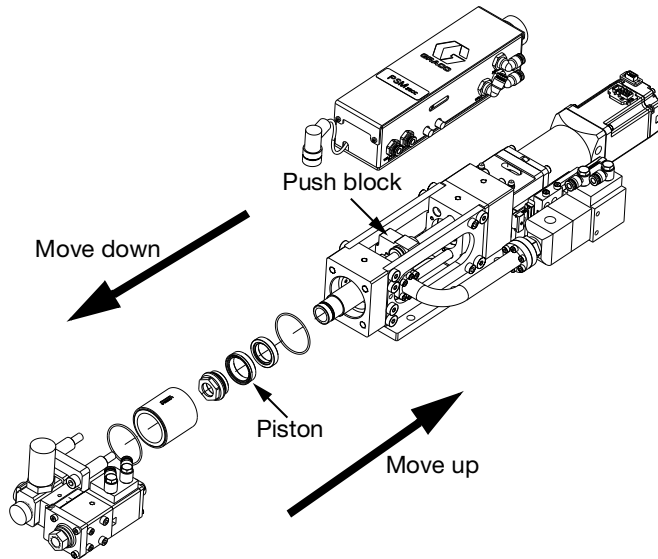

FIG. 33 Piston move up or down

Dispense valve

Dispense valve

Selecting this button enables testing of the Dispense Valve (AB) by controlling the opening or closing of the valve. When the Dispense Valve (AB) is open, the button will be green. When the Dispense Valve (AB) is closed, the button will be gray.





Inlet valve

Inlet valve

Selecting the button enables testing of Inlet Valve (AD) by controlling the opening or closing of the valve. When the Inlet Valve (AD) is open, the button will be green. When the Inlet Valve (AD) is closed, the button will be gray.

Operation

Prime the System

				
<p>This equipment stays pressurized until pressure is manually relieved. To help prevent serious injury from pressurized fluid, such as skin injection and splashing, keep fingers and other body parts away from the spray tip.</p> <p>To avoid injury from toxic fluids or fumes, such as splashing in the eyes or on skin, wear appropriate personal protective equipment.</p>				

1. Place a waste container below Dispense Valve (AB, page 9).
2. Pressurize the Supply Pump Feed (E, page 8), and set the lower pressure to 20 psi (0.14 MPa, 1.4 bar).
3. Go to the Advanced Screen of the PSM control unit (F, page 8). Select 'Piston move down', the piston moves down until the sensor sends out the stop signal, then set the move speed to 0.2 cc/s.

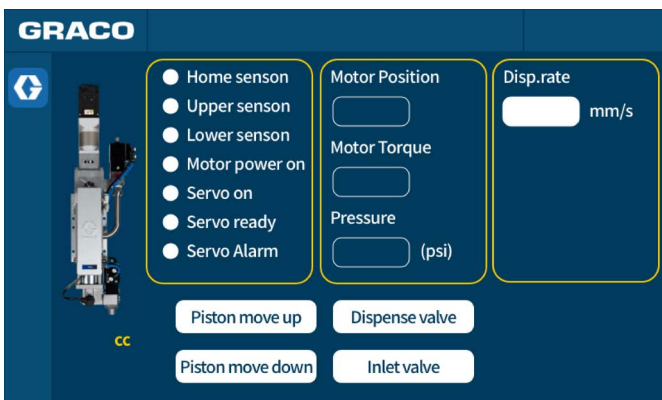



FIG. 34 Advanced Screen

4. Select 'Dispense valve' and 'Reload valve' to turn on the Dispense Valve (AB, page 9) and Inlet Valve (AD, page 9).
5. When the system have a continuous and stable flow, select 'Dispense valve' again to turn off the Dispense Valve (AB, page 9).
6. Return to the Manual Screen 1. Press the  button to execute manual dispense.

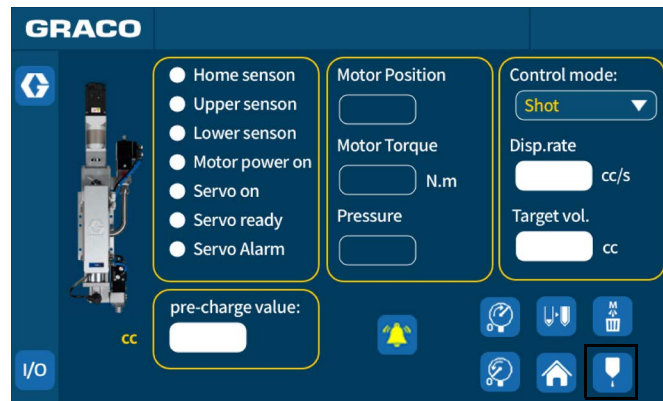



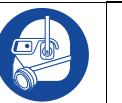



FIG. 35 Manual Screen 1

7. Dispense several full stroke shots until the PSM Metering Unit (H, page 8) is free of air.

Daily Start Up

				
<p>This equipment stays pressurized until pressure is manually relieved. To help prevent serious injury from pressurized fluid, such as skin injection and splashing, keep fingers and other body parts away from the spray tip.</p> <p>To avoid injury from toxic fluids or fumes, such as splashing in the eyes or on skin, wear appropriate personal protective equipment.</p>				

For daily start of the system, follow the below steps.

1. Turn on the air for the supply pump and PSM Metering Unit. Check the air pressure for the supply pump.
2. Turn on the Main Power Switch (BD, page 10) of PSM Control Unit (F, page 8).

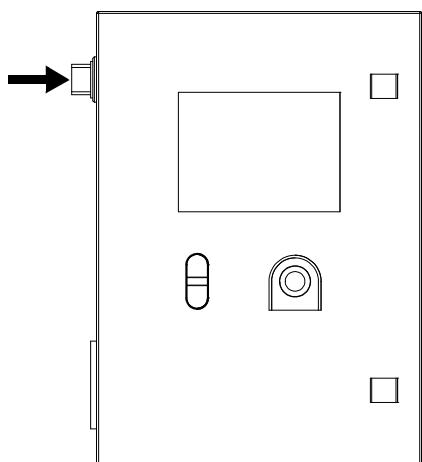

FIG. 36 Main Power Switch of Control Unit

3. Pull up the Emergency Stop Switch (BC, page 10). Then press the green button of Servo Driver Power On/Off Buttons (BB, page 10) to turn on the power for the PSM Drive Assembly (AE, page 9).

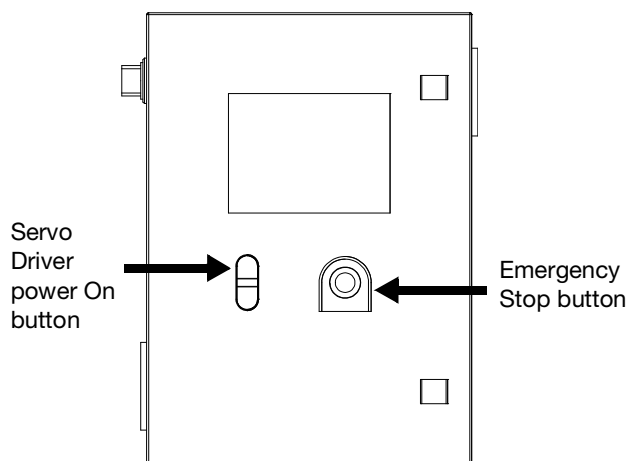



FIG. 37 Servo Driver Power ON and Emergency Stop Buttons



4. Place a waste container below the Dispense Valve (AB, page 9).
5. Go to the Automatic Main Screen 1 - Main. Then press  to execute "Home" order. Message of "Auto-Back Home" in the information bar indicates successful "Home" order.

If the PSM system is connected with robot or motion table, follow the steps 6 to 7. **If the PSM system is used independently,** follow the steps 8 to 11.

For connection of robot or motion table: Follow steps 6 to 7.

6. on the Automatic Main Screen, select "Shot" for control mode, and purge out materials about 1 to 2 cc.
7. On the Automatic Main Screen, select the correct control mode and get ready for running the system.

For independent use of PSM system: follow steps 8 to 11.

8. On the Advanced Setup Screen, press  to display System Main Screen. On the System Main Screen, press  to display Manual Screen 1.

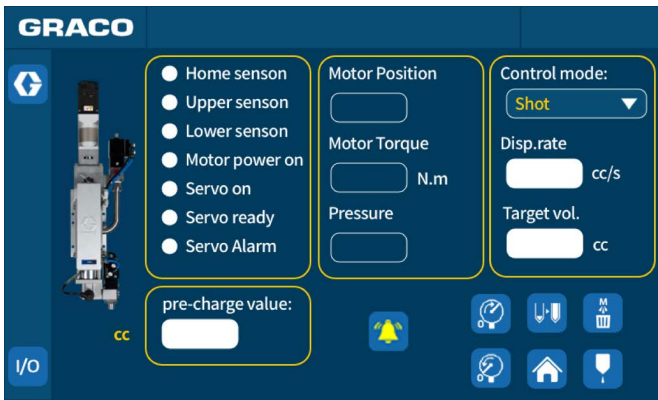





FIG. 38 Manual Screen 1

9. On the Manual Screen 1, select the “Shot” control mode and then press  to execute manual dispense.
10. Press  to display System Main Screen. Then press  to display Automatic Screen 1 - Main.
11. On the Automatic Screen 1 - Main, select the correct control mode and get ready for running the system.

Weight Check

Perform the weight check Procedure at startup and after rebuild.



This equipment stays pressurized until pressure is manually relieved. To help prevent serious injury from pressurized fluid, such as skin injection and splashing, keep fingers and other body parts away from the spray tip.

To avoid injury from toxic fluids or fumes, such as splashing in the eyes or on skin, wear appropriate personal protective equipment.

1. Prepare several cups.
2. Weigh one cup and record the weight.

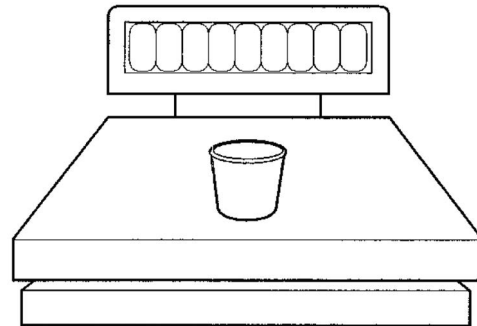

3. Dispense into a waste container to prime the PSM metering Unit.
4. Place the cup under Dispense Valve (AB, page 9) and cycle the machine one time.
5. Repeat by using a cup each time.
6. Re-weigh all cups and record weights.
7. Subtract weight of empty cups from weight of filled cups to get material weights.
8. Check if the material weights stay within normal range. The normal range changes per operators needs.

Add Communication Module

Install Communication Module

1. Install the communication module onto the lower guide rail of the control board.



2. Connect the Modbus RTU communication cable, connect the DB9 connector to the communication module X2 interface, and install the M12 4-core plug on the other end to the control board CON1.



3. Install the RJ45 network cable through the board connector, connect the RJ45 network communication cable, connect one end to the board connector, and the other end to the communication module X3 interface.



4. Installing power cables.

Setup Communication Module

1. Go to 'SYCON.net' website.
2. Download and open 'Ethernet Device Setup' installation package.
3. Use 'Ethernet Device Setup' to search for gateway modules.

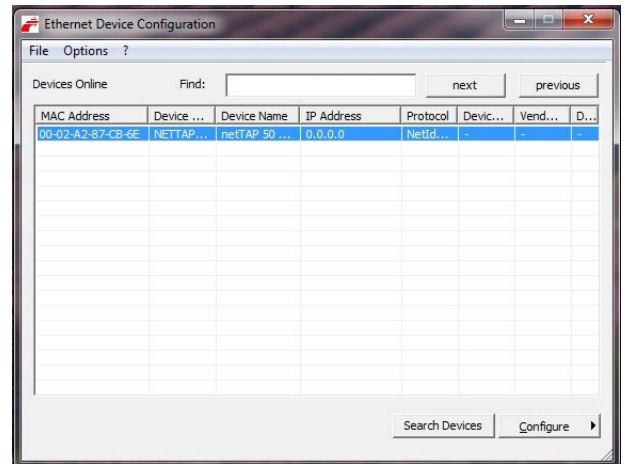
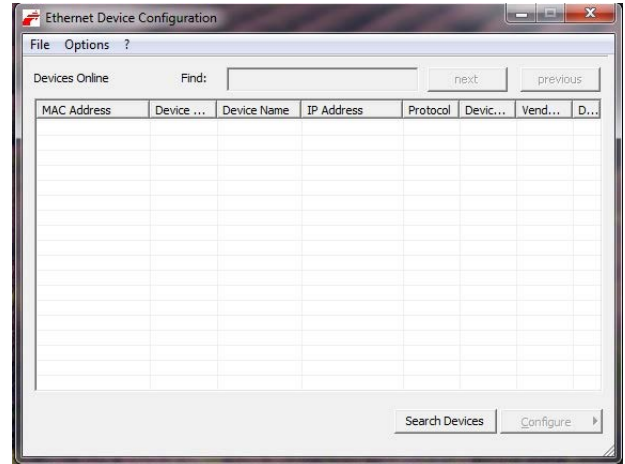

4. Set gateway module IP address.

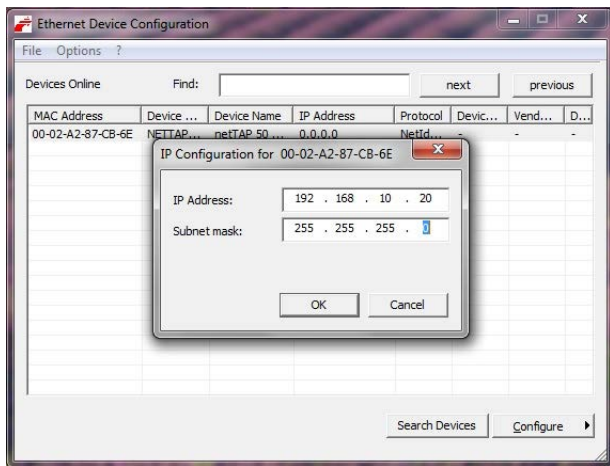
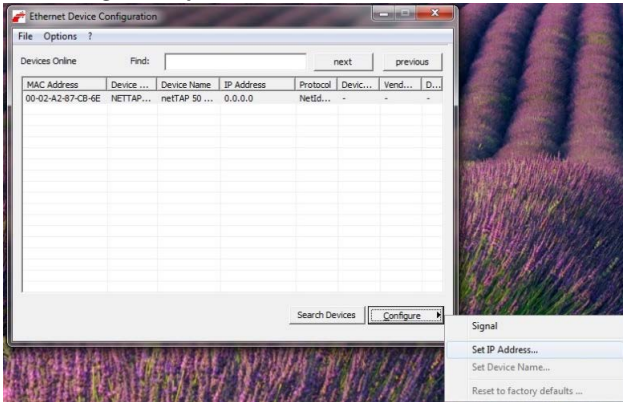

5. Using SYCON.net, open the file 'PSM_GW_MODBUS_EIP.spj'.

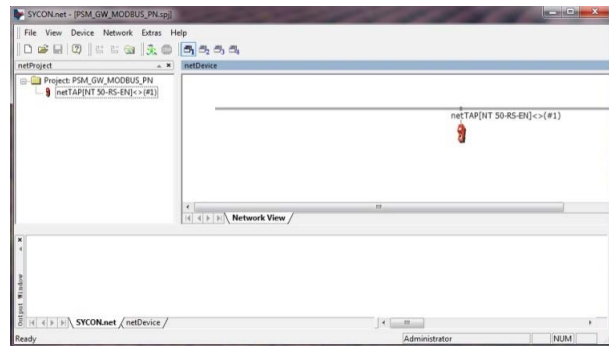
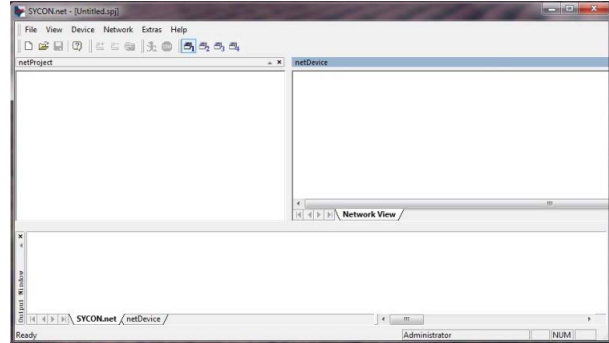

6. Using SYCON.net, open the file and set the gateway module connection method to TCP, and set the search IP range.

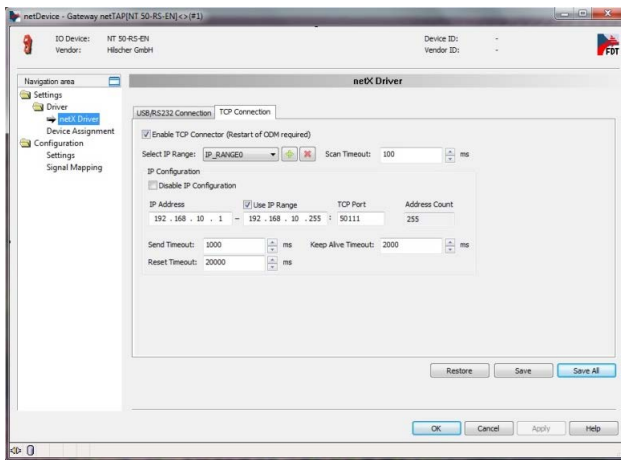
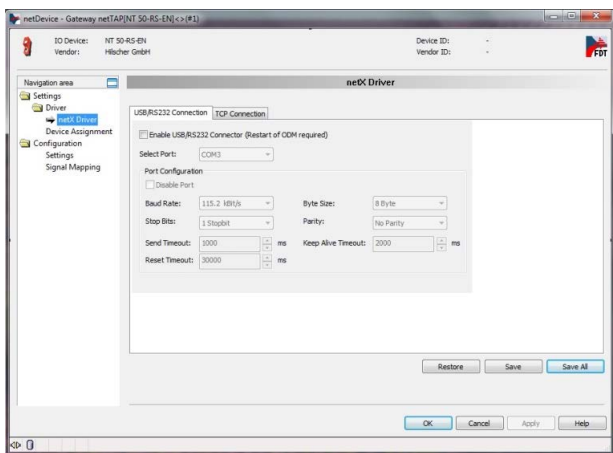
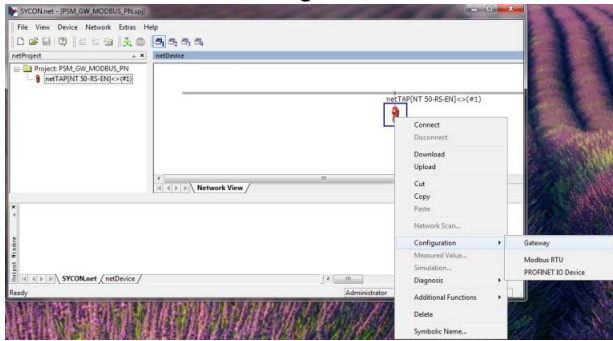

7. Search gateway, establish connection.

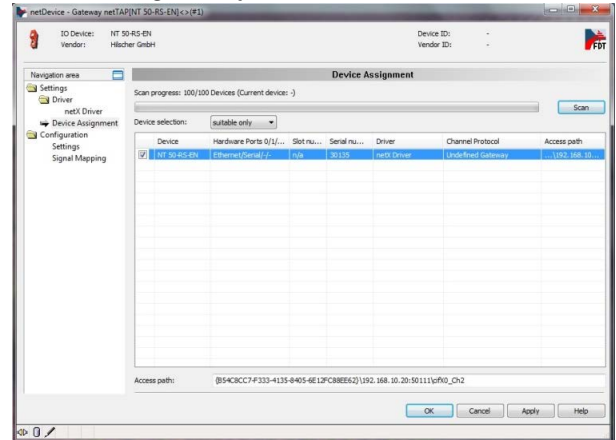

8. Download firmware.

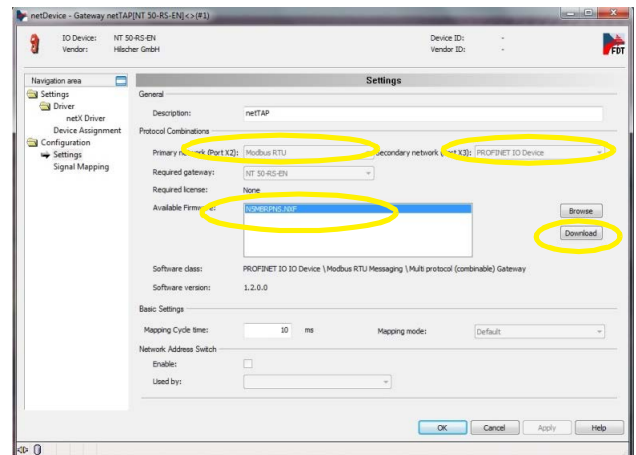
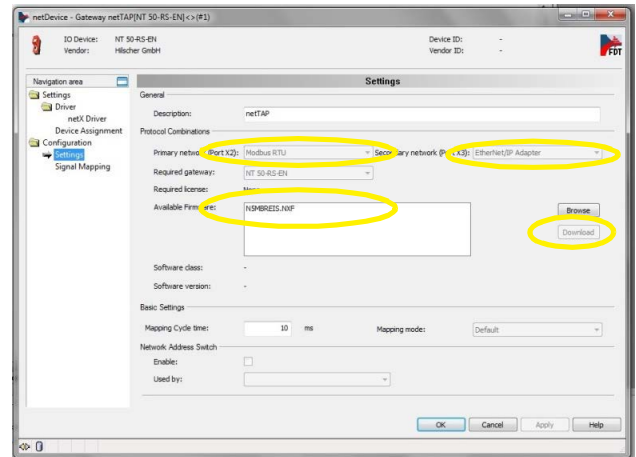

9. After downloading Firmware, repeat steps 1-5 to reset the module IP and establish a connection.

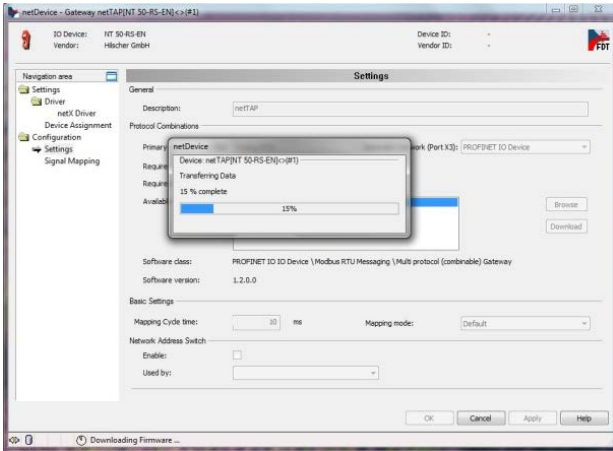

10. Download the configuration file.

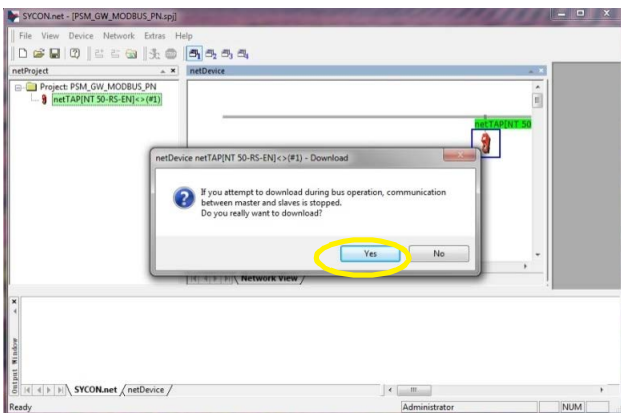
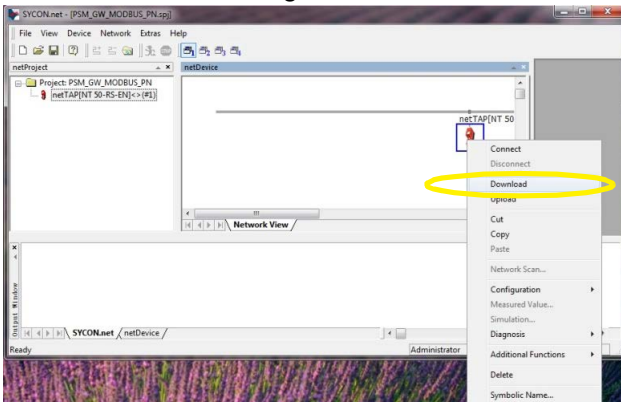

Shutdown

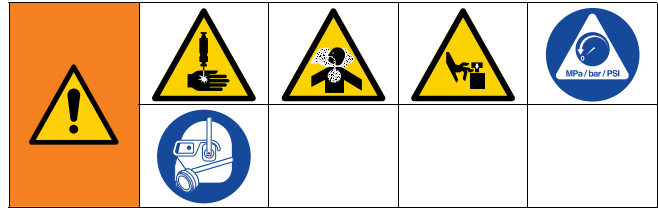

This equipment stays pressurized until pressure is manually relieved. To help prevent serious injury from pressurized fluid, such as skin injection, splashing fluid and moving parts, follow **Pressure Relief Procedure**.
To avoid injury from toxic fluids or fumes, such as splashing in the eyes or on skin, wear appropriate personal protective equipment.

1. Place a waste container below the Dispense Valve (AB, page 9).
2. Perform the **Pressure Relief Procedure** on page 47.
3. Turn off the system power.
4. Wipe the dispense outlet with a clean rag. Be careful to avoid contact between dispense materials.
5. If necessary, isolate the output needle from the air by using sealing medium, such as alcohol, kerosene or oil paper. Chose proper sealing medium according to different types of materials.
6. Turn off the air supply.

Pressure Relief Procedure

 Follow the Pressure Relief Procedure whenever you see this symbol.

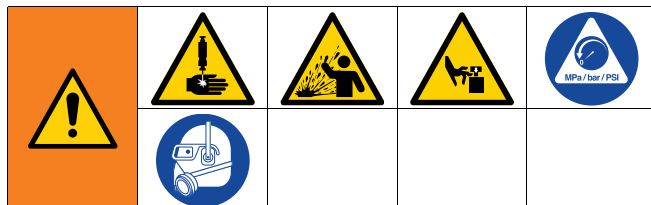

This equipment stays pressurized until pressure is manually relieved. To help prevent serious injury from pressurized fluid, such as skin injection, splashing fluid and moving parts, follow the Pressure Relief Procedure when you stop dispensing and before cleaning, checking, or servicing the equipment.

1. Close the Bleed-type Master Air Valve (D, page 8) (required in the system).
2. Place a waste container below the Dispense Valve (AB, page 9).
3. Go to System main screen of the PSM control unit (F, page 8), then select 'Pressure relief'.
 - The system will identify whether the Inlet Valve (AD, page 9) is closed. If the Inlet Valve (AD, page 9) is opened, it will be closed. Then the Dispense Valve (AB, page 9) will be opened. The whole system pressure is relieved.

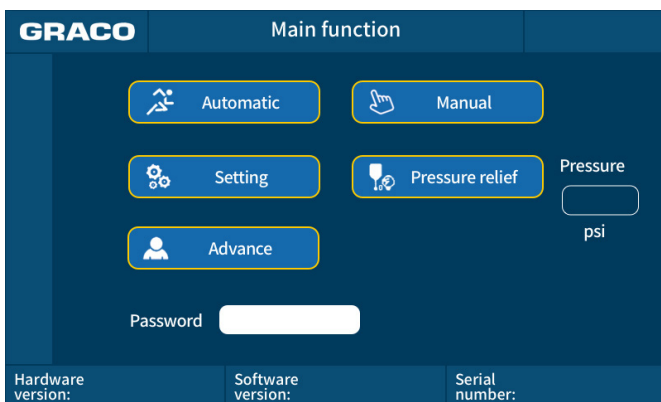
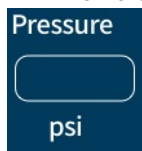

FIG. 39 System Main Screen

4. Turn off the system power and the air supply when the fluid pressure drops to ZERO.



Flush the Equipment



To avoid fire and explosion, always ground equipment and waste container. To avoid static sparking and injury from splashing, always flush at the lowest possible pressure.

- Flush out old fluid with compatible solvent before introducing a new fluid.
- Use the lowest possible pressure when flushing.
- All fluid components are compatible with common solvents.
- To flush the system, put a waste container below the Dispense Valve (AB, page 9), and circulate a compatible solvent through the system for several times until the Dispense Valve dispenses the compatible solvent. Then drain the compatible solvent

Maintenance

Preventive Maintenance

There is a grease filled secondary seal/bearing area on each valve shaft (Dispense Valve (AB, page 9)) and Inlet Valve (AD, page 9). Every 10,000 cycles or twice each month, new grease should be flushed across this area.

To grease the valve:

1. Remove the fitting from the front or back of the valve. For the detailed information, please check IQ Dispense Valves Instructions and Parts Manual

333585, and 1K Ultra-Lite Instructions and Part List Manual 308876.

2. Pump grease (115982) with grease gun (117792) across the valve until clean grease comes out the other side.
3. Reinstall the fitting.

NOTE: The maintenance schedule changes with different material types and actual machine using situations.

Maintenance Schedule

Item	Task	Daily	Monthly	Quarterly	Half year	Yearly
1	Check the power and air pressure for the system.	✓				
2	Clean and inject grease to the Inlet Valve (AE, page 8) and the Dispense Valve (AB, page 9).		✓			
3	Check the Piston Observation Hole (AG, page 9) of the PSM Metering Unit (H, page 8).		✓			
4	Check and tighten the screws and nuts of the moving parts.			✓		
5	Replace the seal kits of Inlet Valve (AD, page 9) and the Dispense Valve (AB, page 9).			✓		
6	Inject grease to the lubricated kits of the PSM Metering Unit (H, page 8).				✓	
7	Replace the rods and needles of the Inlet Valve (AD, page 9) and the Dispense Valve (AB, page 9).				✓	
8	Replace pistons and O-rings of the PSM Metering Unit (H, page 8).				✓	
9	Calibration the pressure sensor.				✓	
10	Replace the metering tube.					✓

Recycling and Disposal

End of Product Life

At the end of the product's useful life, dismantle and recycle it in a responsible manner.

- Perform the **Pressure Relief Procedure**, page 47.
- Drain and dispose of fluids according to applicable regulations. Refer to the material manufacturer's Safety Data Sheet.
- Remove motors, circuit boards, LCDs (liquid crystal displays), and other electronic components. Recycle according to applicable regulations.
- Do not dispose of electronic components with household or commercial waste. 
- Deliver remaining product to a recycling facility.

Troubleshooting

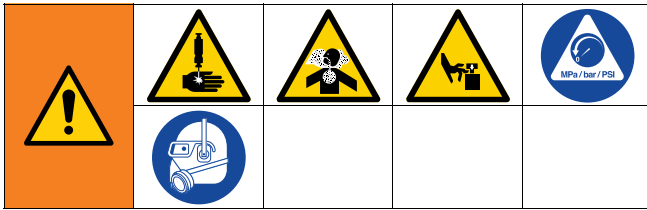

1. Follow **Pressure Relief Procedure**, page 47, before checking or repairing the system.
2. Check all possible remedies before disassembling the equipment.
3. Turn off and disconnect all power.

Problem	Cause	Solution
Display module completely dark	No power	Verify Main Power Switch (BD, page 10) and Control Power Buttons (BB, page 10) are ON
	Thrown breaker	Check machine breakers and reset
	Loose connection	Tighten screen data cable
	Bad display module	Replace display module
No material or incorrect amount of material dispensed	Dispense Valve (AB, page 9) closed	Verify dispense valve works normally and supply air pressure is within range
	Needle clogged	Replace needle
	Supply pump ball valve closed (if installed)	Open ball valve
	Cartridge or pail empty	Exchange cartridge or pail
	Supply pump clogged	Clean supply pump
	Air in PSM metering Unit	Purge and prime the system
Significant material leaking from pump seal	Pump shaft and/or shaft seal worn	Remove pump shaft assembly and reinstall pump rebuild kit
Material weight incorrectly dispensed	Needle clogged	Replace needle.
	Dispense Valve (AB, page 9) or fluid lines clogged	Clean Dispense Valve (AB, page 9) or fluid lines
	Dispense Valve (AB, page 9) opened or closed incorrectly	<ol style="list-style-type: none"> 1. Verify Dispense Valve's (AB, page 9) inlet air pressure. 2. Inspect Dispense Valve (AB, page 9) air cylinder and adapters for leaks.
	Input air reduced or removed	Reconnect input air line to system. Increase air pressure regulator adjustment
	Inlet Valve (AD, page 9) not closed (if installed)	<ol style="list-style-type: none"> 1. Inspect the Inlet Valve (AD, page 9) for wear and tear. 2. Verify rotary cylinder inlet pressure.
	Inlet Valve (AD, page 9) leaking	Inspect needle and seal components
	Piston worn out or broken	Replace piston

Problem	Cause	Solution
Leakage from needle	Air in Dispense valve (AB, page 9)	Slow speed purging
	Dispense Valve (AB, page 9) not closed	<ol style="list-style-type: none"> 1. Verify Dispense Valve's (AB, page 9) inlet air pressure. 2. Clean blockage between needle and seat. 3. Verify solenoid valve status.
	Dispense Valve (AB, page 9) needle and/or seat worn out (pressure reduces after closing the valve)	Replace Dispense Valve (AB, page 9) needle and/or seat
	Damaged or missing gasket (O-ring) between seat and housing (hard seat only)	Replace gasket (O-ring)
	High pressure	See solutions for problem of high pressure
High pressure	Dispense Valve (AB, page 9) clogged	Clean Dispense Valve (AB, page 9)
	Material in needle cured	Replace needle
	Dispense speed unsuitable for needle	<ol style="list-style-type: none"> 1. Replace the current needle with a bigger gauge. 2. Slow down dispensing speed to decrease working pressure (continuous and stable dispensing pressure should be within a range of 150-400 psi).
	Pressure sensor error	Replace pressure sensor
"Home" error	Error not reset	Pull up E-stop button and press "reset"
	Pressure higher than set point	Go to the Advanced Screen of PSM control unit, select 'Dispense valve' to open Dispense Valve (AB, page 9) to reduce pressure
	"Home" button flashing and waiting	<ol style="list-style-type: none"> 1. Verify reload pressure value is correctly set. 2. Verify air supply. 3. Inspect low level sensor status. 4. Confirmed inlet ball valve is opened (if installed). 5. Verify cartridge or pail is not empty. 6. Verify supply pump is working.
	Servo motor alarm	<ol style="list-style-type: none"> 1. Inspect ball screw and slides are functional. 2. Verify motor and encoder cable are connected.

Problem	Cause	Solution
System does not dispense or dispenses in the incorrect amount/mode	Signal error between platform and PSM control unit	1. Verify signal was correctly sent and received. 2. Verify signal cable is correctly connected.
	Wrong "Dispense mode"	Choose correct mode
	Wrong "Dispense type"	Choose correct type
	Wrong mode and/or type trigger method	Choose correct trigger method in "Setup" menu (job can be triggered by outside signal or manually)
Incorrect pressure value	Loose pressure sensor cable or adapters	Exchange cable, tighten adapters
	Pressure sensor error	Replace pressure sensor
	Pressure sensor signal incorrect	Calibrate pressure sensor

Dimensions

PSM Metering Unit, Supply Pump Feed, 25 cc

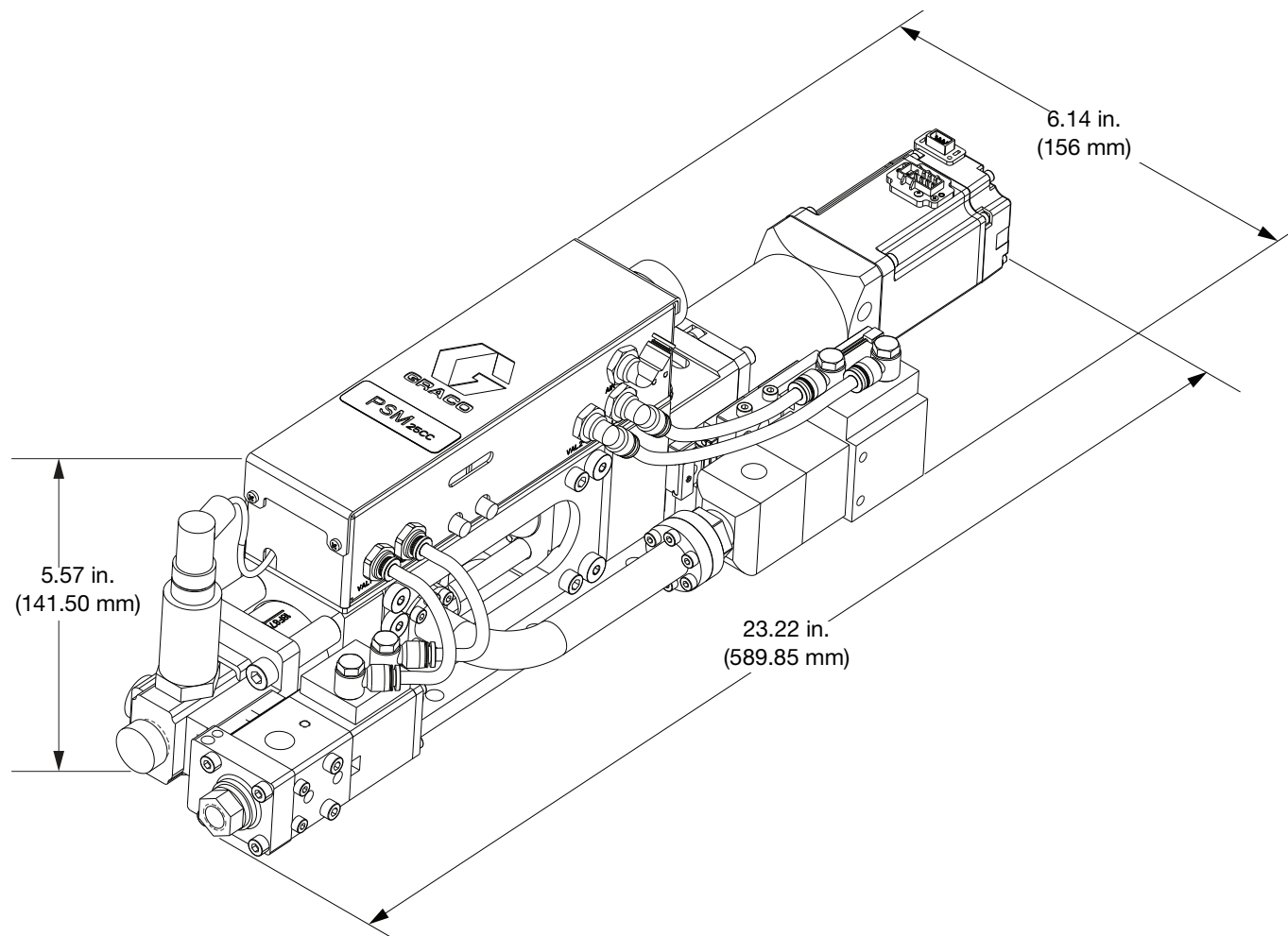

FIG. 40: PSM Metering Unit Dimensions, 25 cc

PSM Metering Unit, Supply Pump Feed, 50 cc

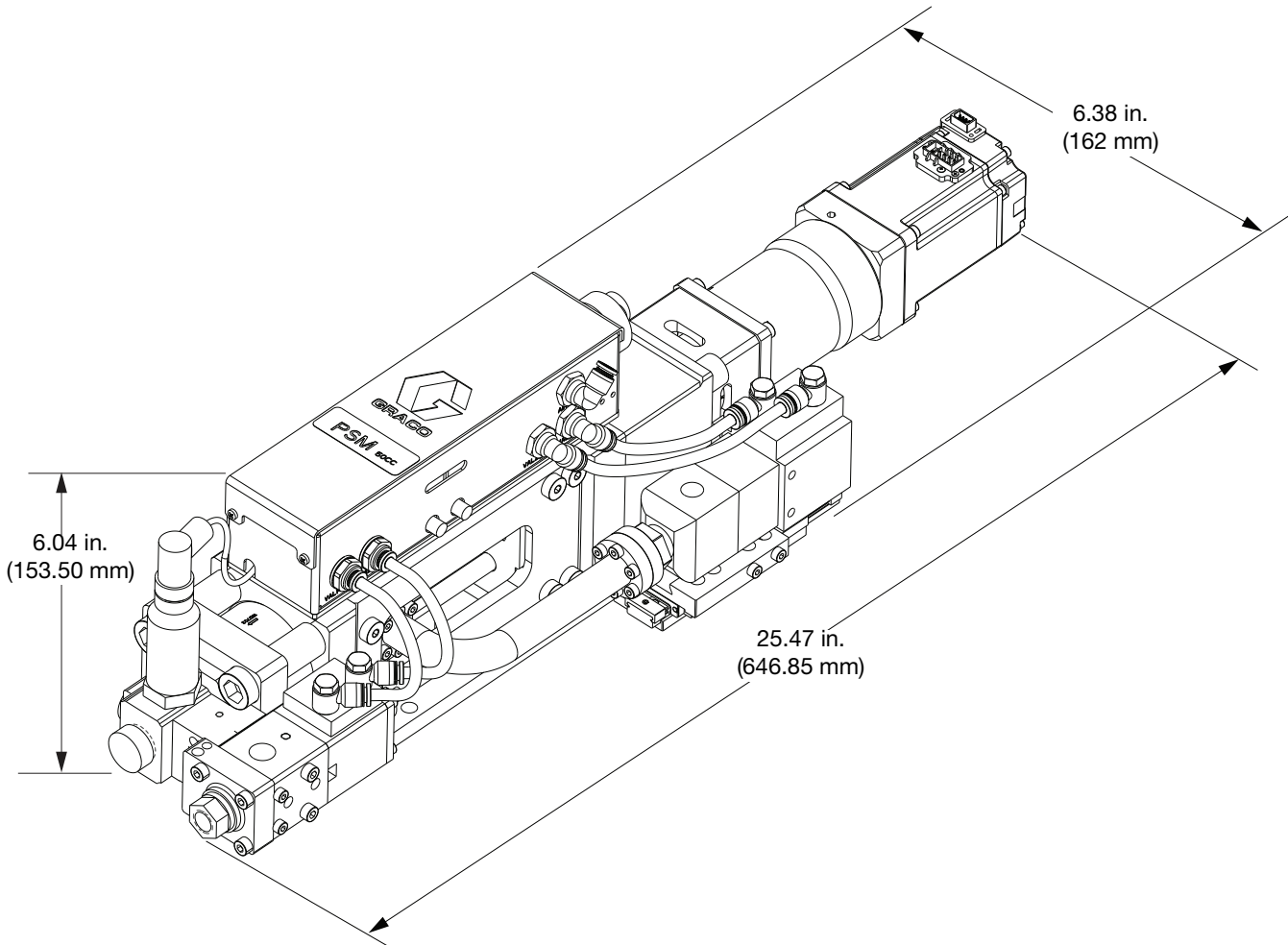

FIG. 41: PSM Metering Unit Dimensions, 50 cc

PSM Metering Unit, Supply Pump Feed, 100 cc

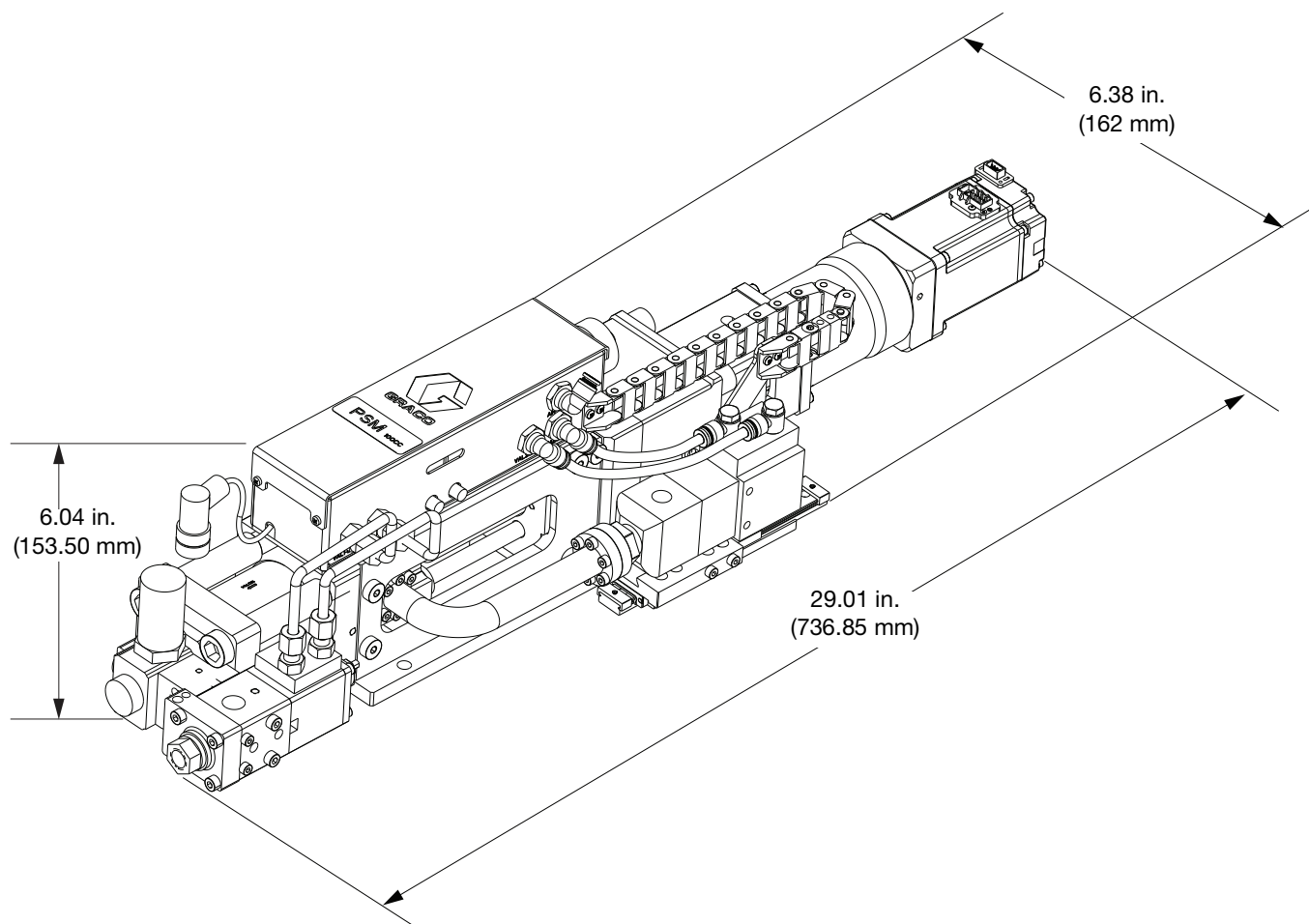

FIG. 42: PSM Metering Unit Dimensions, 100 cc

PSM Control Unit

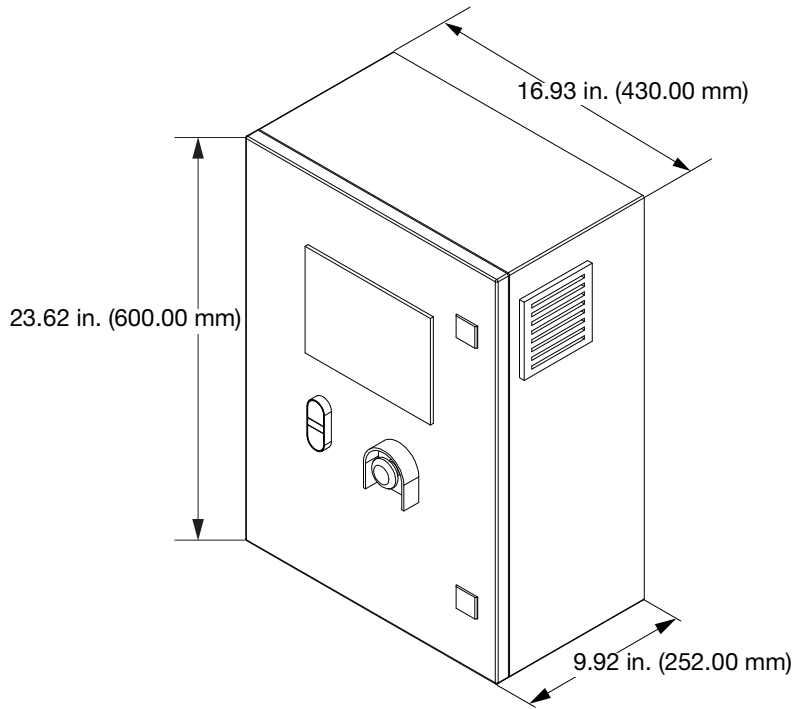

FIG. 43: PSM Control Unit Dimensions

Appendix A - PSM Error Codes

Error code	Error Type	Error Name	Description	Cause	Solution
0	----	No error	----	----	----
1	Error	E-stop	System emergency stops	System Emergency Stop Switch (BC) is pressed	Make sure the system is in safety status. Plug the Emergency Stop Switch (BC), and press the reset button to close the alarm. Note: Execute Home after system emergency stop.
2	Error	Touch lower limit	Moving of metering cylinder touches the lower limit sensor	Improper position of the lower limit sensor	Re-install lower limit sensor
				Damage of lower limit sensor	Replace lower limit sensor
				Drive mechanism error	Repair drive mechanism
3	Error	Touch upper limit	Moving of metering cylinder touches the upper limit sensor	Improper position of the upper limit sensor	Re-install upper limit sensor
				Damage of upper limit sensor	Replace upper limit sensor
				Drive mechanism error	Repair drive mechanism
4	Error	Pre-charge time out	Pre-charge time exceeds the set maximum time	Target pre-charge pressure is set too high	Set proper target pre-charge pressure
				Pre-charge speed is set too low	Set proper pre-charge speed
				Maximum pre-charge time is too short	Set proper maximum Pre-charge time
				Piston seal leaks	Replace piston
				Reload valve leaks	Replace reload valve seal assembly
				Dispense valve leaks	Replace dispense valve seal assembly
				Pressure sensor error	Replace pressure sensor
Drive mechanism error	Repair drive mechanism				
5	Error	Depressurize time out	Depressurization time exceeds the set maximum time	De-pressurization target pressure is set too low	Set proper target de-pressurization pressure
				De-pressurization speed is set too low	Set proper de-pressurization speed
				Maximum de-pressurization time is set too short	Set proper maximum de-pressurization time
				Reload valve leaks	Replace reload valve seal assembly
				Pressure sensor error	Replace pressure sensor
				Drive mechanism error	Repair drive mechanism
6	Error	Reload time out	Reload time exceeds the set maximum reload time	Reload pressure is set too high	Set proper target reload pressure
				Maximum reload time is set too short	Set proper maximum reload time
				Supply Pump System (E) error	Check Supply Pump System
				Reload valve is not open normally	Check Reload valve
				Pressure sensor error	Replace pressure sensor
				Block of Material Supply Line (L)	Clean or replace the line
7	Error	Servo fault	Servo fault	Servo system error	Check servo drive alarm code, or restart the PSM control unit
8	Error	Part A supplier is in low level	Insufficient material for the supply system	Insufficient material in the supply system	Replace supply feeding tank
				Error of material lower level sensor	Check position of the sensor or replace the sensor

Appendix A - PSM Error Codes

Error code	Error Type	Error Name	Description	Cause	Solution
9	Error	Part B supplier is in low level	Insufficient material for the supply system	Insufficient material in the supply system	Replace supply feeding tank
				Error of material lower level sensor	Check position of the sensor or replace the sensor
10	Error	Part A pressure exceeds system limit	Pressure is too high	Dispense outlet line clogged	Clean or replace dispense valve and other outlet parts
				Dispense rate is too fast	Set proper dispense rate, or replace with bigger dispense nozzle
				Dispense Valve (AB) is not open	Check dispense valve and dispense solenoid valve
				Pressure sensor error	Replace pressure sensor
				Maximum working pressure is set too low	Set proper maximum working pressure
13	Error	Servo unit lost power	Servo system power supply error	Power supply breaker of servo breaks	Test supply circuit, check servo, and close breaker
				Servo is not open	Check status of Control Power On/Off buttons (BB), Emergency Stop Switch (BC) and outside emergency stop contact.
14	Error	Inlet valve A does not turn on in time	Inlet valve does not turn on normally	Inlet Valve (AD) error	Check and replace reload valve
				Insufficient air supply pressure	Check air supply pressure
				Reload solenoid valve error	Check or replace reload solenoid valve
				Reload valve close sensor error	Check or replace close sensor of reload valve
				System pressure exceeds the limit pressure of reload valve.	Execute system relief and adjust system pressure in proper range.
16	Error	Dispense valve does not turn on in time	Dispense valve does not turn on normally	Dispense Valve (AB) error	Check and replace dispense valve
				Insufficient air supply pressure	Check system air supply pressure
				Dispense solenoid valve error	Check or replace dispense solenoid valve
				Dispense Valve (AB) close sensor error	Check or replace close sensor of dispense valve
				System pressure exceeds the limit pressure of dispense valve	Execute system relief and adjust system pressure in proper range
17	Error	Reload valve does not turn off in time	Reload valve does not turn off normally	Inlet Valve (AD) error	Check and replace reload valve
				Insufficient air supply pressure	Check system air supply pressure
				Reload solenoid valve error	Check or replace reload solenoid valve
				Reload valve close sensor error	Check or replace close sensor of reload valve
				System pressure exceeds the limit pressure of reload valve.	Execute system relief and adjust system pressure in proper range.
19	Error	Dispense valve does not turn off in time	Dispense valve does not turn off normally	Dispense Valve (AB) error	Check and replace dispense valve
				Insufficient air supply pressure	Check system air supply pressure
				Dispense solenoid valve error	Check or replace dispense solenoid valve
				Dispense Valve (AB) close sensor error	Check or replace close sensor of dispense valve
				System pressure exceeds the limit pressure of dispense valve	Execute system relief and adjust system pressure in proper range

Error code	Error Type	Error Name	Description	Cause	Solution
20	Error	De-pressurize failed	Depressurize fails	When depressurizing, material level in metering cylinder is too high	Execute system de-pressurization, or depressurize by dispensing
				Inlet Valve (AD) leaks	Replace reload valve seal assembly
				Pressure sensor error	Replace pressure sensor
21	Error	Pre-charge failed	Pre-charge fails	When pre-charging, material level in metering cylinder is too low	Change dispense program by adding reload order in proper program workflow.
				Piston seal leaks	Replace piston
				Inlet Valve (AD) leaks	Replace reload valve seal assembly
				Dispense Valve (AB) leaks	Replace dispense valve seal assembly
				Pressure sensor error	Replace pressure sensor
22	Error	Homing fault	Homing fault	Drive mechanism error	Repair drive mechanism
				Home position sensor disabled	Check and replace home position sensor
				Wrong installation position of home position sensor	Check and re-installation Home position sensor
23	Error	Motor torque is over limit	Motor torque is over limit	Drive mechanism error	Repair drive mechanism
				Dispense outlet line clogged	Clean or replace dispense valve and other outlet parts
				Dispense rate is fast	Set proper dispense rate
				Dispense valve is not open	Check Dispense valve and dispense solenoid valve
				Motor error	Check error code, and repair or replace motor
24	Error	Motor peak torque is over limit	Motor peak torque is over limit	Drive mechanism error	Repair drive mechanism
				Dispense outlet line clogged	Clean or replace dispense valve and other outlet parts
				Dispense rate is too fast	Set proper dispense speed
27	Error	Material tube is empty	Material in metering cylinder is empty	Dispense valve is not open	Check Dispense valve and dispense solenoid valve
				Reload target is set too low	Set proper reload position
				Improper reload request mode. For example, setting 'reload after multiple jobs' as reload request mode.	Set proper reload request mode.
36	Error	Reload fault	Reload fails	Improper dispense program	Change dispense program by adding reload order in proper program workflow.
				Reload pressure is set too high	Set appropriate reload target pressure
				Supply system error	Check supply system
				Inlet Valve (AD) is not open normally	Check reload valve
				Pressure sensor error	Replace pressure sensor
48	Deviation	Illegal setting	Invalid preset dispensing program	Dispense Valve (AB) is not closed normally	Check dispense valve and dispense solenoid valve
				Reload line clogged	Clean the reload line or replace parts of the line
				Invalid preset dispensing program	Confirm and reset the program

Appendix A - PSM Error Codes

Error code	Error Type	Error Name	Description	Cause	Solution
49	Deviation	Illegal command	The current dispense program order is invalid and not able to be executed	The current dispense program order is invalid and not able to be executed	check dispense program
50	Deviation	Home is lost	System home position lost	Emergency stop, upper switch sensor, or lower switch sensor is activated	Execute Home
				Home is not executed after system start	
51	Deviation	Reload is request	Material in the metering cylinder is lower than the set 'reload request position'.	Material in the metering cylinder is lower than the set 'reload request position'	Execute reload
52	Deviation	Purge is request	The system have not dispensed for over the set 'purge alarm time'.	The system have not dispensed over the set 'purge alarm time'.	Execute dispense or purge immediately. If necessary, clean dispense valve and other outlet parts.
53	Deviation	Idle timeout	The system idles for longer time than the set 'Max idle time in job'.	The system idles for longer time than the set 'Max idle time in job'	The system automatically ends job per the set depressurize parameters
55	Deviation	system pressure relieve	The system is in pressure relief status.	The system is in pressure relief status	Complete system relief before getting the system back to normal

Schematics

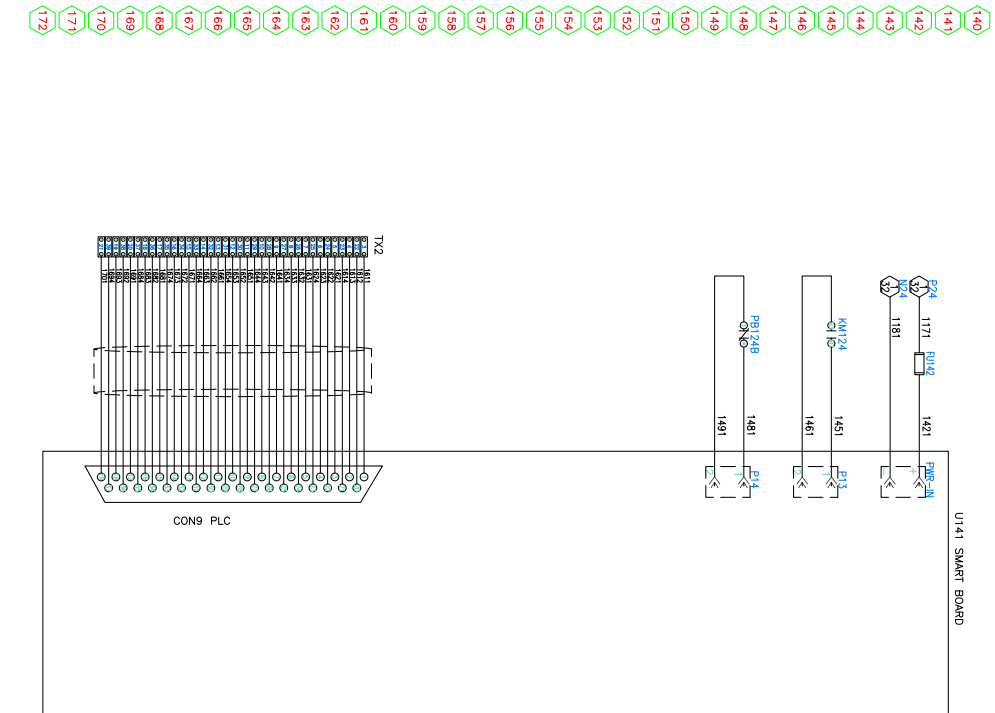
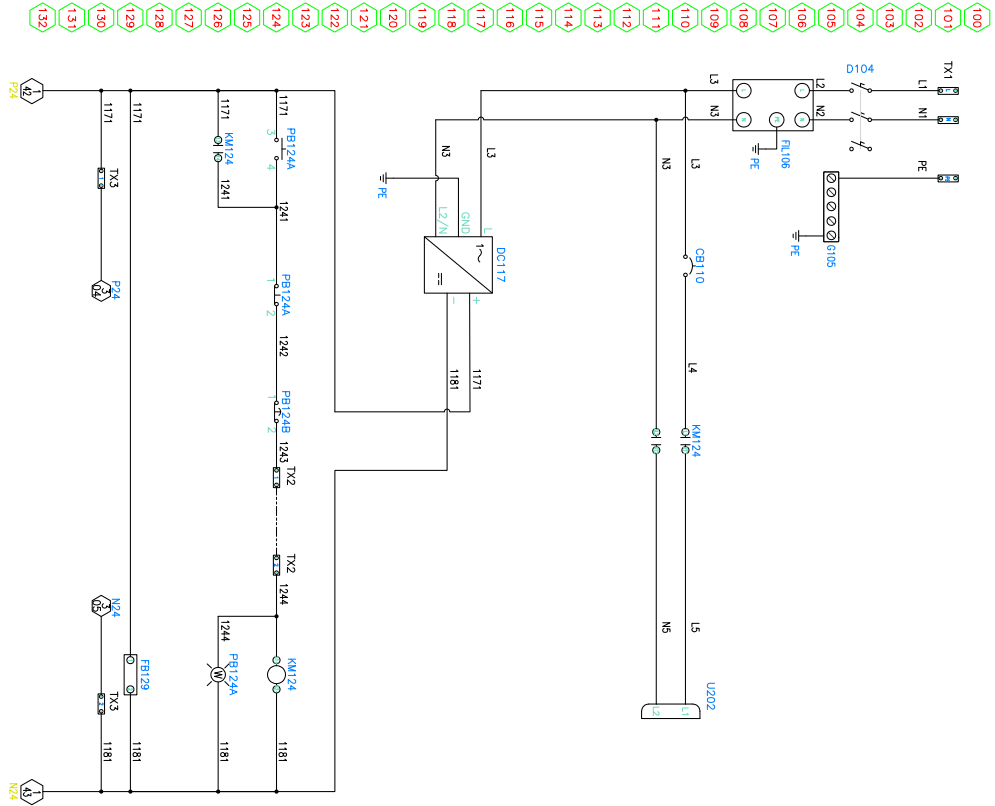

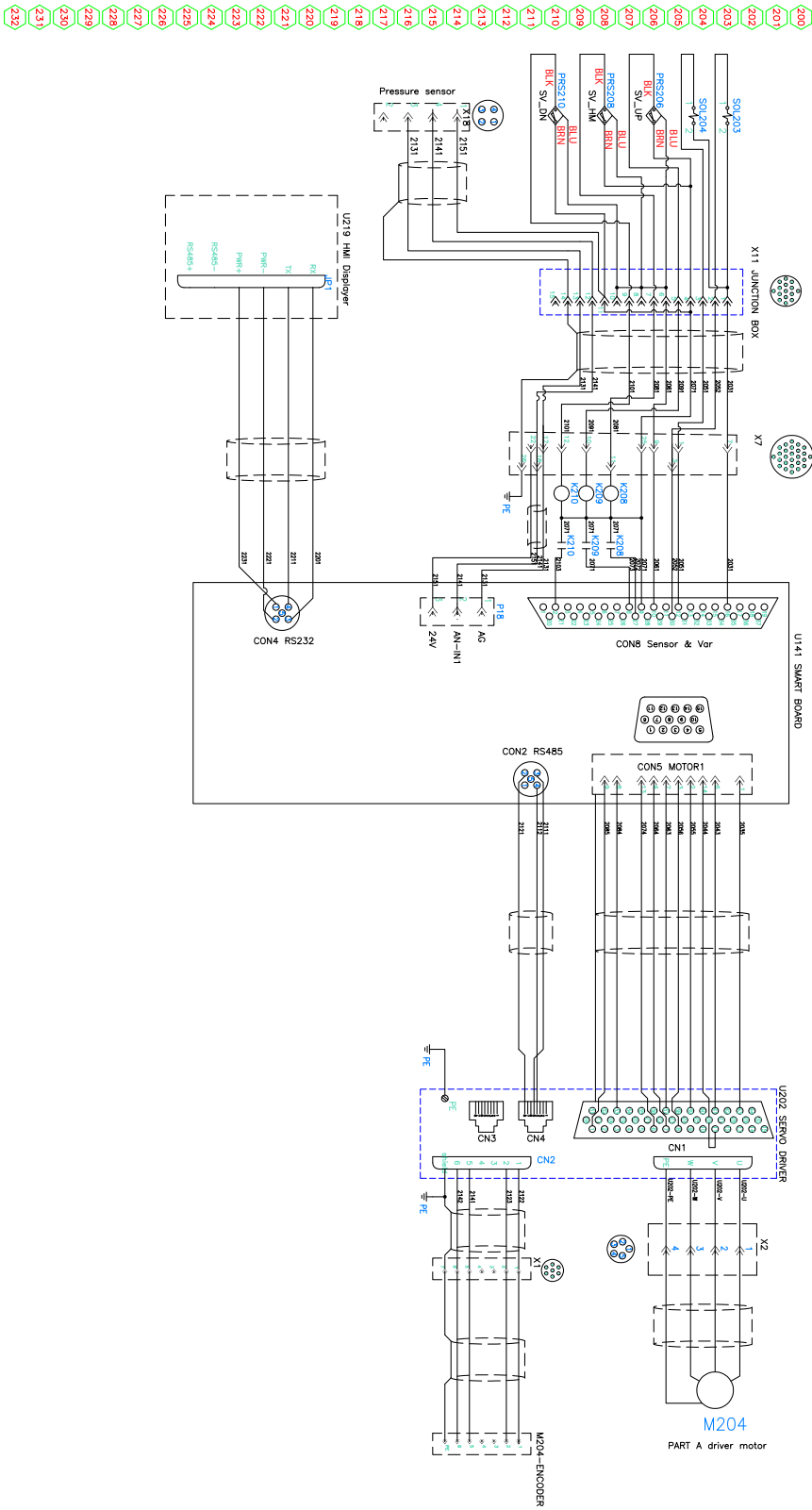

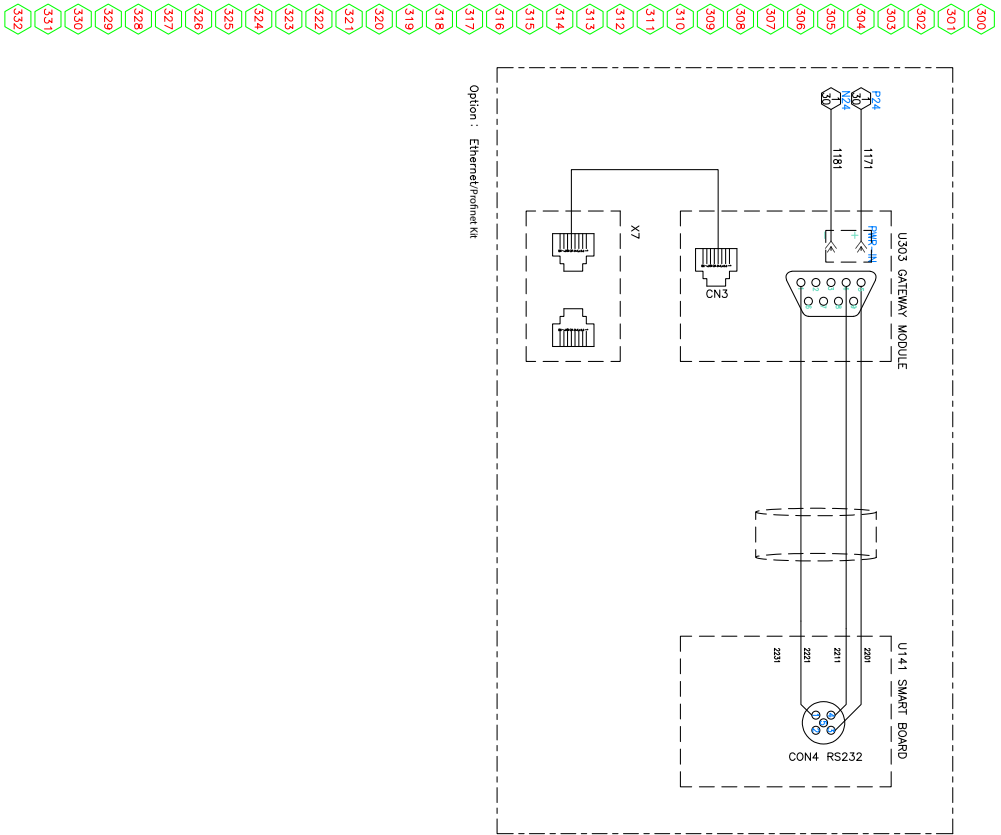

Cables Route

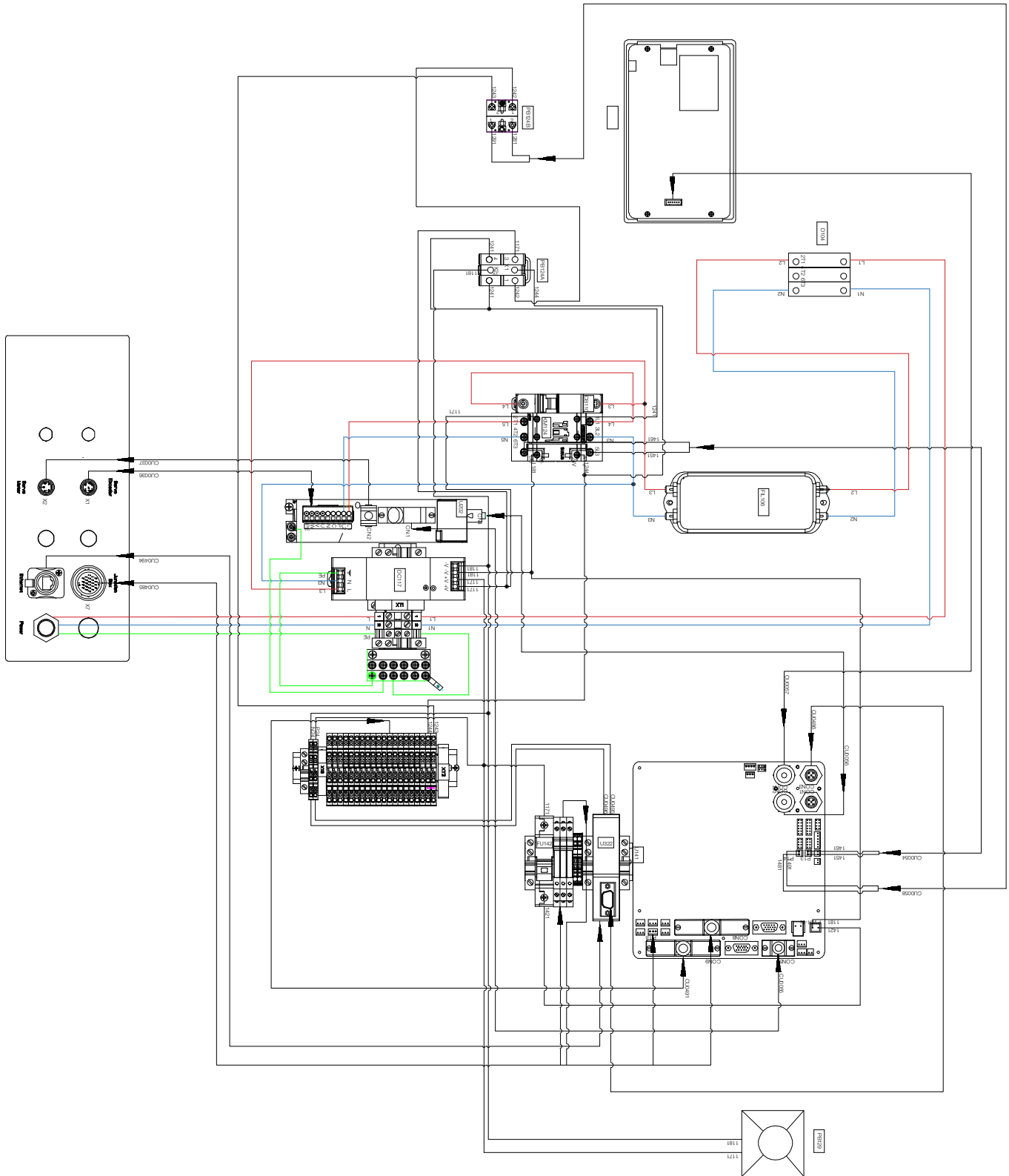

Internal Cables

Part	Description	Qty.
CU0036	CABLE, U202 to X1	1
CU0037	CABLE, U202 to X2	1
CU0485	CABLE, P18/CON8 to X7	1
CU0054	CABLE, P13 to KM1	1
CU0055	CABLE, CON5 to U202	1
CU0056	CABLE, CON2 to U202	1
CU0057	CABLE, CON4 to TP1	1
CU0058	CABLE, P14 to SB1	1
CU0491	CABLE, CON9 to XT2	1
CU0486	CABLE, CON1 to U322	1
CU0494	CABLE, U322 CN3 to Ethernet	1
CU0495	CABLE, XT3 to U322+	1
CU0496	CABLE, XT3 to U322-	1

Terminal I/O Route

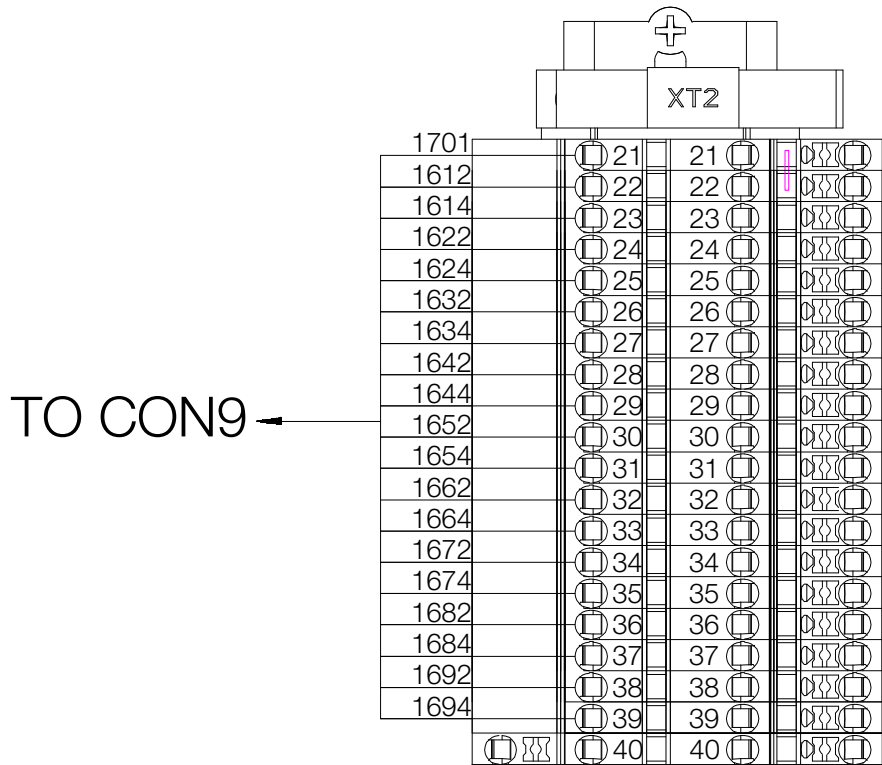
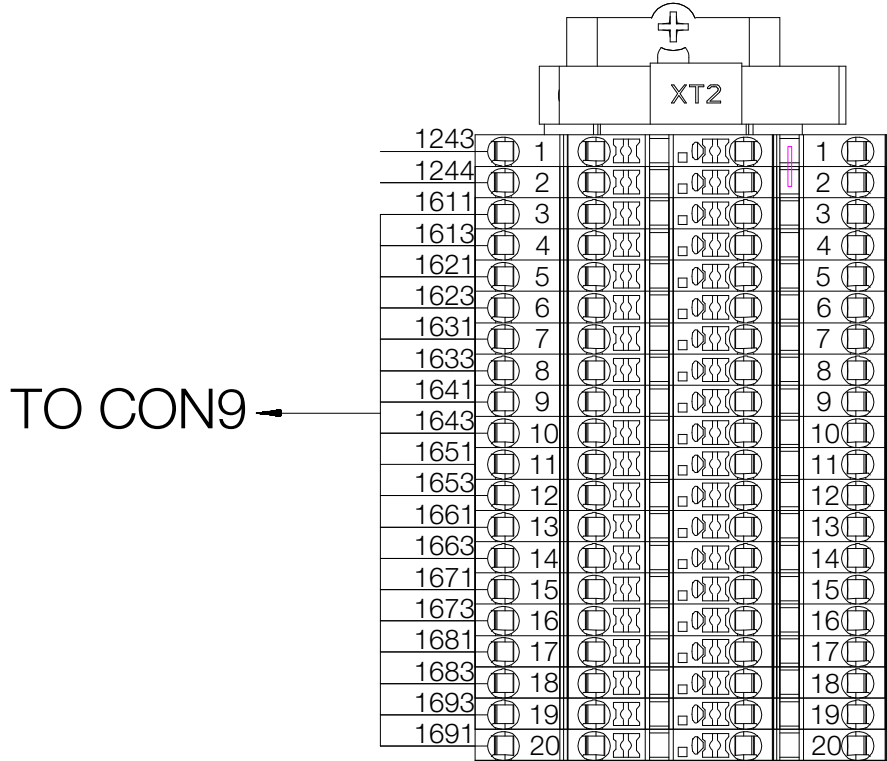

NOTE: The short cable is factory standard. It's reserved for remote Emergency Stop (NC). For I/O signal name, see **I/O Signals**, page 67.

I/O Signals

Terminal Number	Wire Label	Signal Name	Comments
1	1243	CUST_IN ESTOP +	Dry contact, passive signal, normally closed
2	1244	CUST_IN SETOP -	
3	1611	CUST_IN RELOAD	To work with CUST_ IN COMMON, dry contact, normally open. When connected to CUST_ IN COMMON, signal is ON. When disconnected to CUST_ IN COMMON, signal is OFF.
4	1613	CUST_IN JOB START	
5	1621	CUST_IN DISPENSE	
6	1623	CUST_IN STYLE BIT4	
7	1631	CUST_IN PURGE	
8	1633	CUST_IN STYLE BIT5	
9	1641	CUST_IN ALARM RESET	
10	1643	CUST_IN MODE SELECT	
11	1651	CUST_IN PRESS RELIEF	
12	1653	CUST_IN STYLE BIT0	
13	1661	CUST_IN STYLE BIT1	
14	1663	CUST_IN STYLE BIT2	
15	1671	CUST_IN STYLE BIT3	
16	1673	CUST_IN PRECHARGE	
17	1681	SPARE	
18	1683	SPARE	
19	1693	CUST_IN COMMON	
20	1691	CUST_IN FLOW CMD +	0-10V analog signal
21	1701	CUST_IN FLOW CMD -	
22	1612	CUST_OUT STANDBY	To work with CUST_ OUT COMMON, dry contact, normally open.
23	1614	CUST_OUT READY	
24	1622	CUST_OUT INJOB	When the signal output is ON, the signal line is connected to the CUST_ IN COMMON; When the signal output is OFF, the signal line is disconnected with the CUST_ IN COMMON.
25	1624	CUST_OUT IN DISPENSE	
26	1632	CUST_OUT IN RELOAD	
27	1634	CUST_OUT ALARM	
28	1642	CUST_OUT PURGE REQ	
29	1644	CUST_OUT RELOAD REQ	
30	1652	CUST_OUT ERROR CODE BIT0	
31	1654	CUST_OUT ERROR CODE BIT1	
32	1662	CUST_OUT ERROR CODE BIT2	
33	1664	CUST_OUT ERROR CODE BIT3	
34	1672	CUST_OUT ERROR CODE BIT4	
35	1673	CUST_OUT ERROR CODE BIT5	
36	1681	CUST_OUT IN PRESS RELIEF	
37	1682	CUST_OUT VOLUME OK	
38	1692	CUST_OUT COMMON	
39	1694	CUST_OUT COMMON	

Profinet map

Controller input from PLC output

Name	PLC address	Units	In Byte	Description
GATE_IN_CMD_BIT0-15	IW100	0 Job Start	1-2	used to start job, normal
		1 Dispense		used to start dispensing in bead mode or shot mode
		2 Reload		used to start reloading material.
		3 Purge		used to start purge.
		4 Alarm Reset		used to reset error
		5 Mode Select		used to set working mode in automatic 0 means shot mode 1 means bead mode
		6 Pressure Relief		used to open dispense valve and relief pressure in metering system
		7 Precharge Start		
GATE_IN_STYLE_NO	IW102		3-4	0-39, for select style
GATE_IN_JOB_NO	IW104		5-6	0-39, for select job
GATE_IN_RATE_CMD	IW106		7-8	0-5000, to control the dispense flow rate

Controller output to PLC input

Name	PLC address	Units	In Byte	Description
GATE_OUT_STATUS	QW100	0 Ready	1-2	
		1 In Dispense		
		2 Completed		
		3 In Reload		
		4 Purge Request		
		5 Reload Request		
		6 Alarm		
		7 Standby		
		8 In Job		
		9 In Purge		
		15 Heart Beat		
GATE_OUT_ERR_CODE	QW102		3-4	
GATE_OUT_JOB_VOL	QW104		5-6	Integer, should multiply by 0.1, unit is CC
GATE_OUT_DISP_RATE	QW106		7-8	Integer, should multiply by 0.01, unit is CC/s
GATE_OUT_PRESS	QW108		9-10	Integer, unit is PSI
GATE_OUT_MTR_TRQ	QW110		11-12	Integer, should multiply by 0.001, unit is NM
GATE_OUT_JOB_DURATION	QW112		13-14	Integer, unit is s
GATE_OUT_DISP_TIMES	QW114			Dispense times in a job

Timing Chart

Always precharge and reload after each job

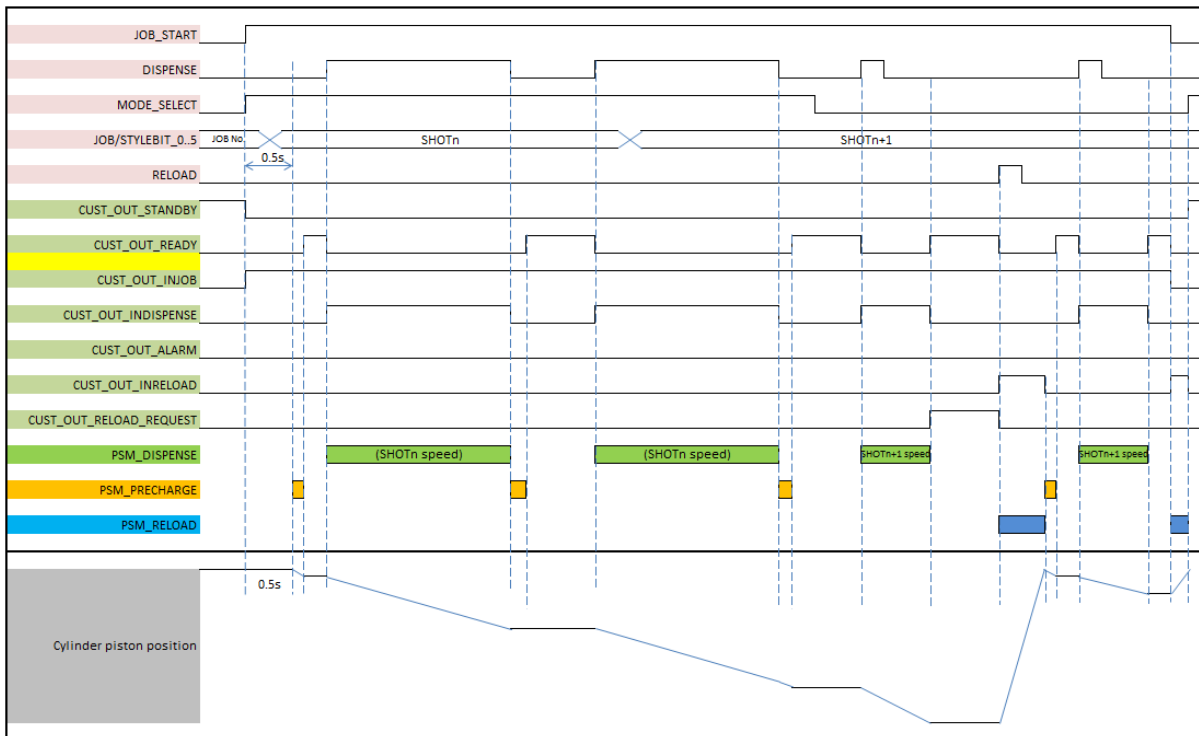

None precharge and reload after each job

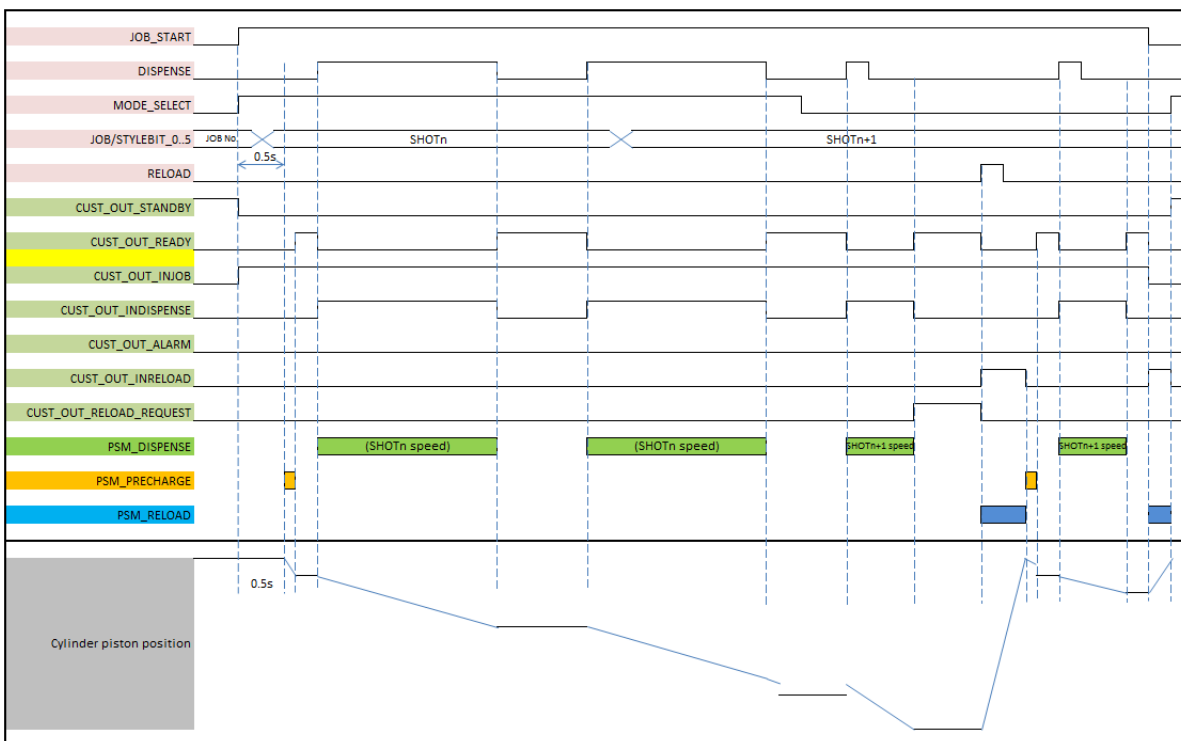

Distributed IO or gateway precharge and reload after each job

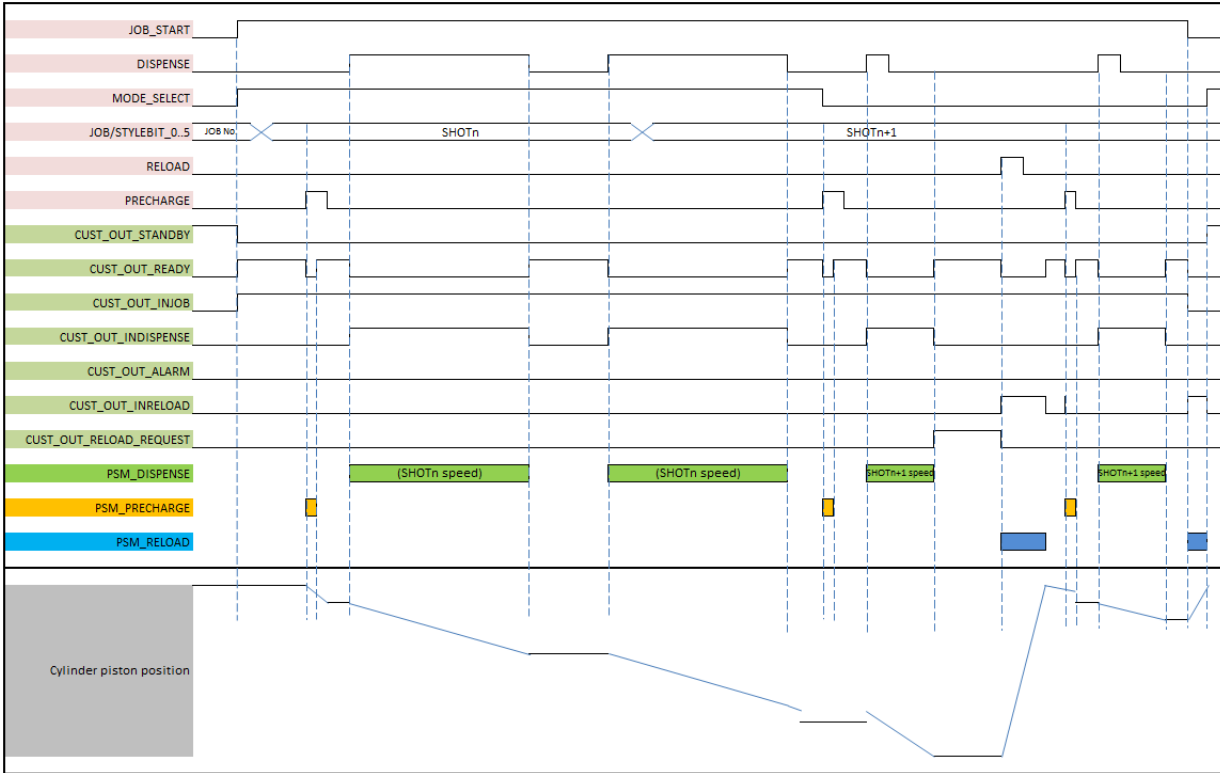

Always precharge and reload after each job with flow rate command

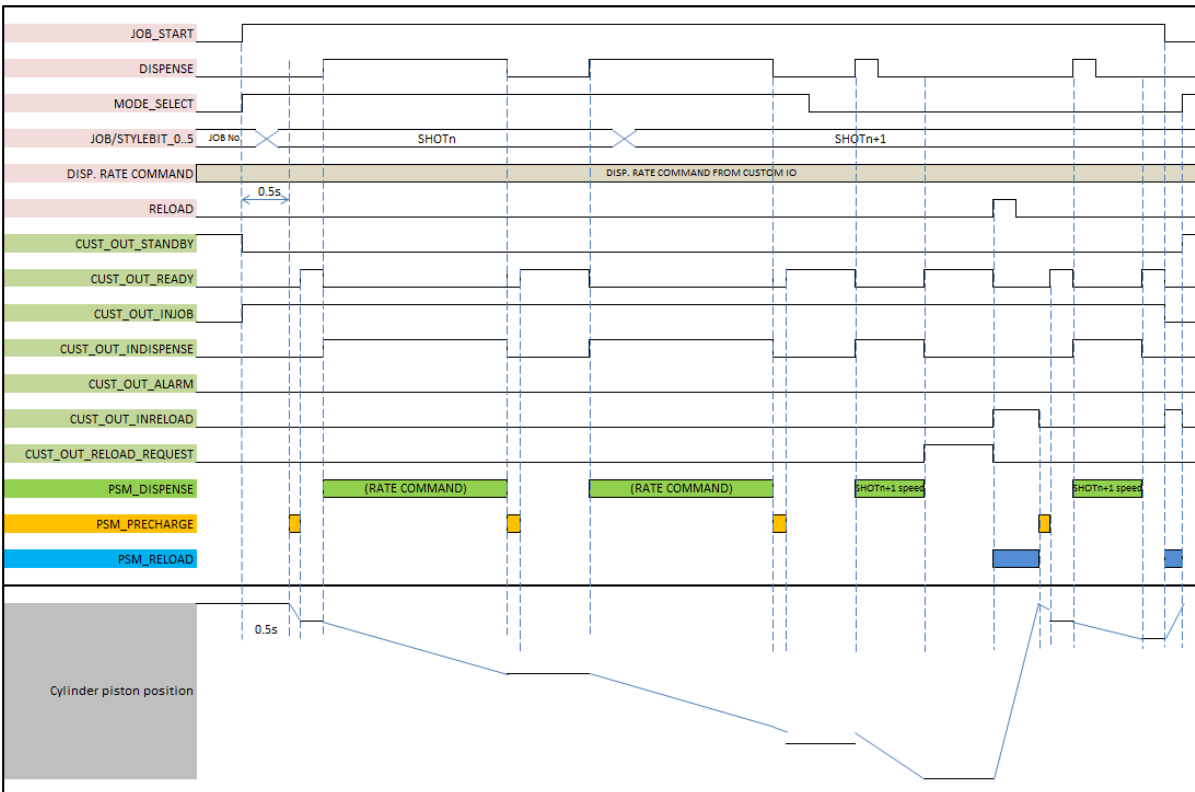

None precharge and reload after each job with flow rate command

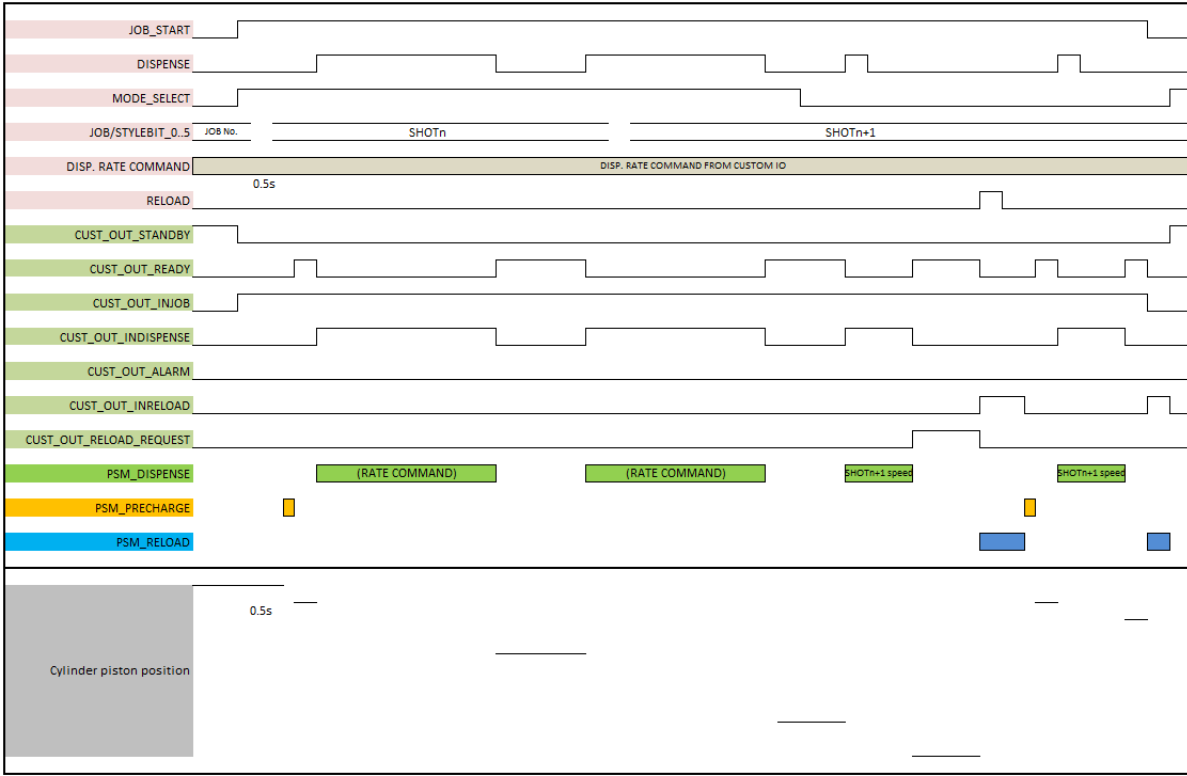

Distributed IO or gateway precharge and reload after each job with flow rate command

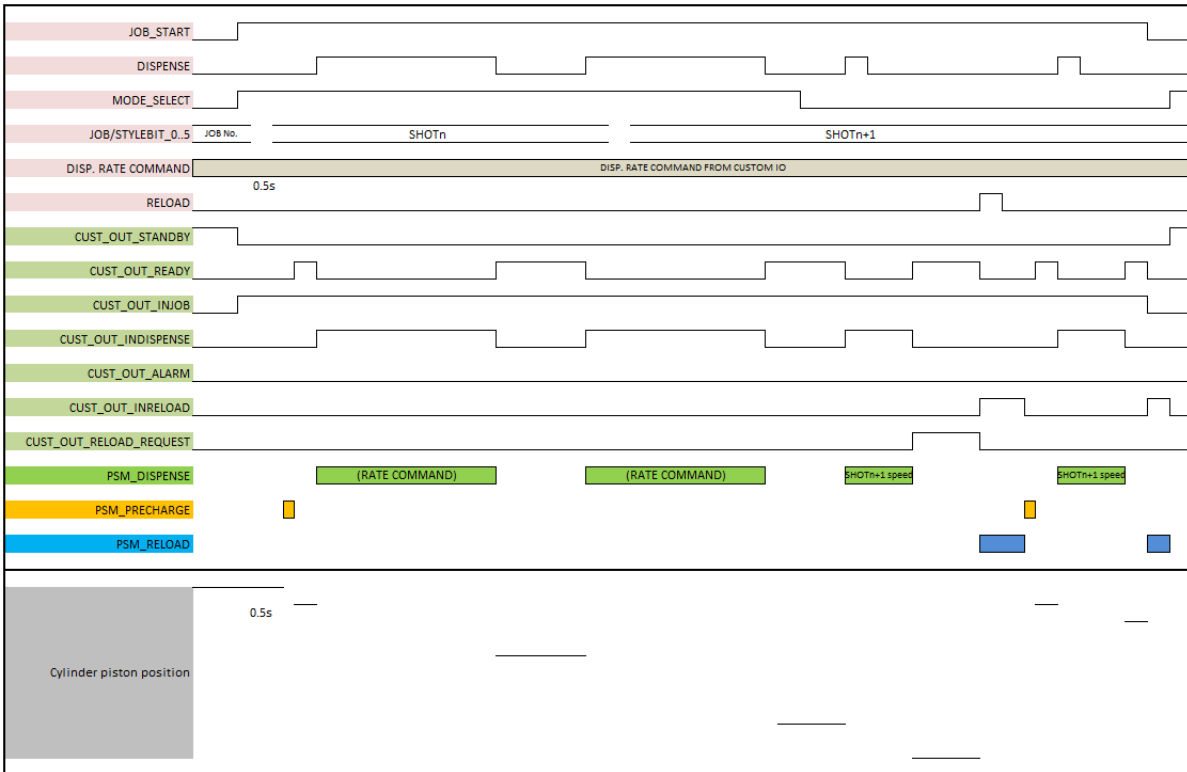

Purge with reloading after purge

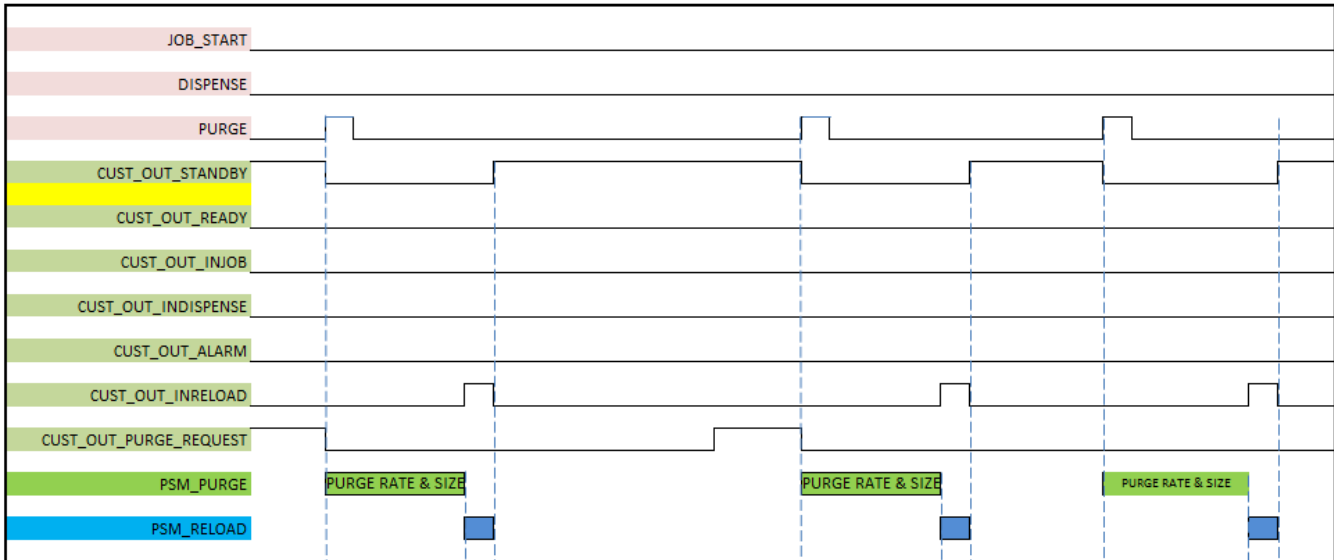

Purge with depressurization after purge

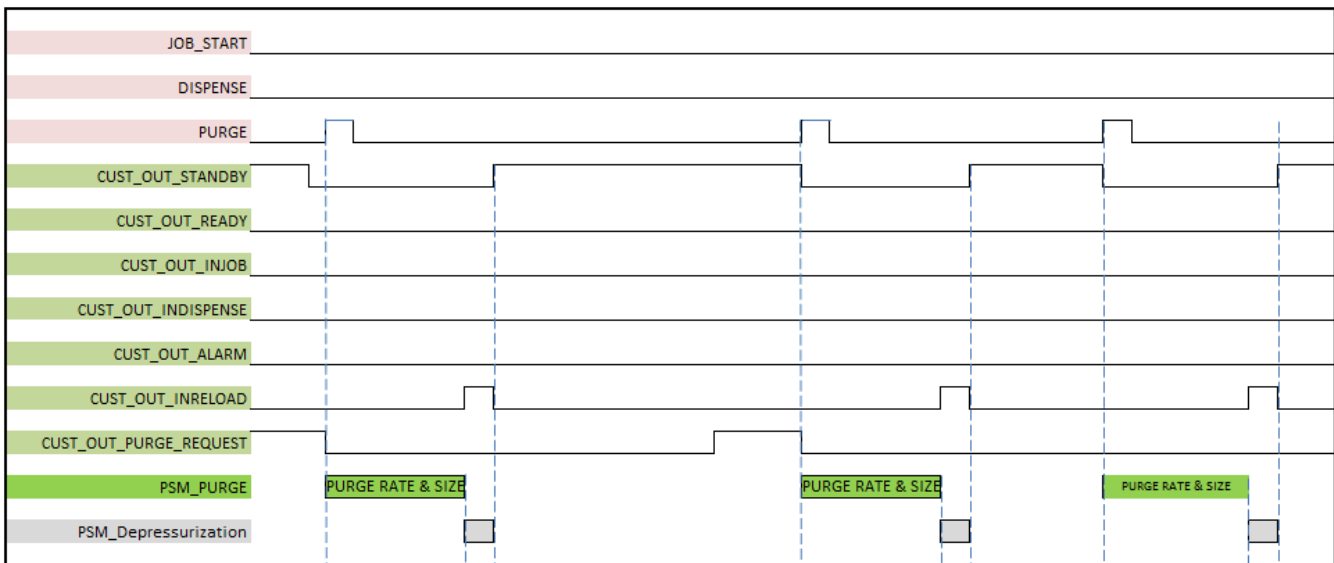

Technical Specifications

PSM System		
	US	Metric
Maximum Inlet Fluid Pressure	25 cc: 1200 psi 50 cc: 3000 psi 100 cc: 3000 psi	25 cc: 8.3 MPa, 83 bar 50 cc: 20.7 MPa, 207 bar 100 cc: 20.7 MPa, 207 bar
Maximum Working Fluid Pressure	25 cc: 1200 psi 50 cc: 3000 psi 100 cc: 3000 psi	25 cc: 8.3 MPa, 83 bar 50 cc: 20.7 MPa, 207 bar 100 cc: 20.7 MPa, 207 bar
Maximum Air Pressure	100 psi	0.7 MPa, 7 bar
Electrical Power	200–240 VAC, 50/60 Hz, 10 A	
Viscosity Range	20–1,000,000 cps	
Wetted Parts	303/304 Stainless Steel, Hard Chrome, Ceramic, UHMWPE, NBR, PTFE	
Shot Size Range ⁽¹⁾	25 cc: 0.01–25 cc 50 cc: 0.2–50 cc 100 cc: 0.5–100 cc	
Shot Size Repeatability	1%	
Maximum Flowrate ⁽²⁾	25 cc: 10 cc/s 50 cc: 18 cc/s 100 cc: 20 cc/s	
Maximum Working Temperature	158°F	70°C
Inlet / Outlet Sizes		
Air Inlet Size	1/4 in.	6 mm
Fluid Inlet Size	1/4 in. npt (f)	
Fluid Outlet Size	1/4 in. npt (f)	
Weight		
PSM Metering Unit	25 cc: 24 lb 50 cc: 28 lb 100 cc: 35 lb	25 cc: 11 kg 50 cc: 13 kg 100 cc: 16 kg
PSM Control Unit	71 lb	32 kg
Notes		
All trademarks or registered trademarks are the property of their respective owners.		
(1) Minimum shot size varies based on the material type and the customer tolerance requirements.		
(2) Maximum flowrate varies based on the material viscosity.		

California Proposition 65

CALIFORNIA RESIDENTS

 **WARNING:** Cancer and reproductive harm – www.P65warnings.ca.gov.

Graco Standard Warranty

Graco warrants all equipment referenced in this document which is manufactured by Graco and bearing its name to be free from defects in material and workmanship on the date of sale to the original purchaser for use. With the exception of any special, extended, or limited warranty published by Graco, Graco will, for a period of twelve months from the date of sale, repair or replace any part of the equipment determined by Graco to be defective. This warranty applies only when the equipment is installed, operated and maintained in accordance with Graco's written recommendations.

This warranty does not cover, and Graco shall not be liable for general wear and tear, or any error, damage or wear caused by faulty installation, misapplication, abrasion, corrosion, inadequate or improper maintenance, negligence, accident, tampering, or substitution of non-Graco component parts. Nor shall Graco be liable for error, damage or wear caused by the incompatibility of Graco equipment with structures, accessories, equipment or materials not supplied by Graco, or the improper design, manufacture, installation, operation or maintenance of structures, accessories, equipment or materials not supplied by Graco.

This warranty is conditioned upon the prepaid return of the equipment claimed to be defective to an authorized Graco distributor for verification of the claimed defect. If the claimed defect is verified, Graco will repair or replace free of charge any defective parts. The equipment will be returned to the original purchaser transportation prepaid. If inspection of the equipment does not disclose any defect in material or workmanship, repairs will be made at a reasonable charge, which charges may include the costs of parts, labor, and transportation.

THIS WARRANTY IS EXCLUSIVE, AND IS IN LIEU OF ANY OTHER WARRANTIES, EXPRESS OR IMPLIED, INCLUDING BUT NOT LIMITED TO WARRANTY OF MERCHANTABILITY OR WARRANTY OF FITNESS FOR A PARTICULAR PURPOSE.

Graco's sole obligation and buyer's sole remedy for any breach of warranty shall be as set forth above. The buyer agrees that no other remedy (including, but not limited to, incidental or consequential damages for lost profits, lost sales, injury to person or property, or any other incidental or consequential loss) shall be available. Any action for breach of warranty must be brought within two (2) years of the date of sale.

GRACO MAKES NO WARRANTY, AND DISCLAIMS ALL IMPLIED WARRANTIES OF MERCHANTABILITY AND FITNESS FOR A PARTICULAR PURPOSE, IN CONNECTION WITH ACCESSORIES, EQUIPMENT, MATERIALS OR COMPONENTS SOLD BUT NOT MANUFACTURED BY GRACO. These items sold, but not manufactured by Graco (such as electric motors, switches, hose, etc.), are subject to the warranty, if any, of their manufacturer. Graco will provide purchaser with reasonable assistance in making any claim for breach of these warranties.

In no event will Graco be liable for indirect, incidental, special or consequential damages resulting from Graco supplying equipment hereunder, or the furnishing, performance, or use of any products or other goods sold hereto, whether due to a breach of contract, breach of warranty, the negligence of Graco, or otherwise.

FOR GRACO CANADA CUSTOMERS

The Parties acknowledge that they have required that the present document, as well as all documents, notices and legal proceedings entered into, given or instituted pursuant hereto or relating directly or indirectly hereto, be drawn up in English. Les parties reconnaissent avoir convenu que la rédaction du présente document sera en Anglais, ainsi que tous documents, avis et procédures judiciaires exécutés, donnés ou intentés, à la suite de ou en rapport, directement ou indirectement, avec les procédures concernées.

Graco Information

Sealant and Adhesive Dispensing Equipment

For the latest information about Graco products, visit www.graco.com.

For patent information, see www.graco.com/patents.

TO PLACE AN ORDER, contact your Graco distributor, go to www.graco.com, or call to identify the nearest distributor.

If calling from the USA: 1-800-746-1334

If calling from Asia Pacific: 00-86-512-6260-5711 or 00-86-21-2310-6198

If calling from Europe: 00-32-89-770-862

All written and visual data contained in this document reflects the latest product information available at the time of publication. Graco reserves the right to make changes at any time without notice.

Original instructions. This manual contains English. MM 3A7273E

Graco Headquarters: Minneapolis

International Offices: Belgium, China, Japan, Korea

GRACO INC. AND SUBSIDIARIES • P.O. BOX 1441 • MINNEAPOLIS MN 55440-1441 • USA
Copyright 2023, Graco Inc. All Graco manufacturing locations are registered to ISO 9001.

www.graco.com
Revision E, October 2024