

## EcoQuip 2™ Dual Line Vapor Abrasive Blast System

3A6825H

EN

*Vapor abrasive blast system for coating removal and surface preparation. For professional use only.*

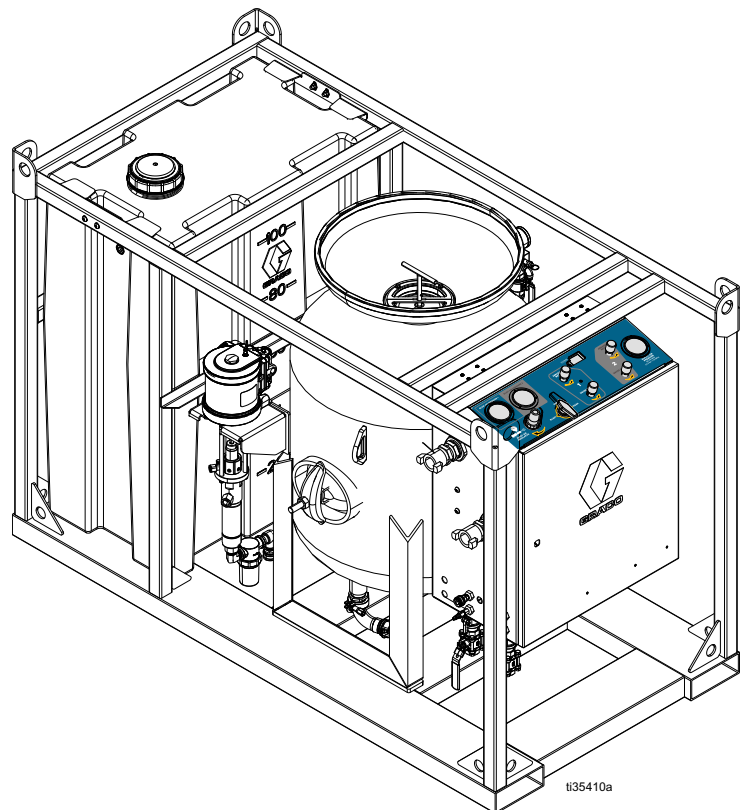
150 psi (1.03 MPa, 10.3 bar) Maximum Working Pressure

See page 3 for model information, including approvals.



### Important Safety Instructions

Read all warnings and instructions in this manual before using the equipment. Save these instructions.






# Contents

<b>Related Manuals</b> . . . . .	<b>2</b>	<b>Standby</b> . . . . .	<b>25</b>
<b>Models</b> . . . . .	<b>3</b>	<b>Shutdown</b> . . . . .	<b>25</b>
Packages . . . . .	3	Drain the Pot . . . . .	26
<b>Warnings</b> . . . . .	<b>4</b>	Winterize the Equipment . . . . .	27
<b>Component Identification</b> . . . . .	<b>8</b>	Clean the Water Tank . . . . .	28
MediaTrak Controls . . . . .	9	<b>Troubleshooting</b> . . . . .	<b>29</b>
<b>Installation</b> . . . . .	<b>10</b>	<b>Repair</b> . . . . .	<b>35</b>
Grounding (ATEX systems only) . . . . .	10	Replace the DataTrak Battery . . . . .	35
Lifting the System . . . . .	10	Replace the Pinch Hose . . . . .	36
Select Blast Hose Control . . . . .	11	Replace the DataTrak Fuse . . . . .	37
Blasting on Higher Surfaces . . . . .	11	<b>Parts</b> . . . . .	<b>38</b>
Inspect Pinch Hoses . . . . .	11	EcoQuip 2 System . . . . .	38
Connect Blast Hoses and Supply Air Hose . . . . .	12	Base (Frame and Pot) . . . . .	44
Connect the Water Supply . . . . .	13	Enclosure . . . . .	46
<b>Setup</b> . . . . .	<b>14</b>	Blast Hoses . . . . .	54
Fill the Water Tank . . . . .	14	Tubing . . . . .	55
Fill Pot with Abrasive Media . . . . .	15	<b>Kits and Accessories</b> . . . . .	<b>56</b>
Pressurize the Pot . . . . .	16	Blast Hoses with Control Hose/Cable . . . . .	56
<b>Operation</b> . . . . .	<b>17</b>	Blast Hoses without Control Hose/Cable . . . . .	56
Pressure Relief Procedure . . . . .	17	Control Hoses/Cable with Blast Hose . . . . .	56
Adjust Blast Pressure . . . . .	18	Nozzles . . . . .	56
Wet the Internal Water Lines . . . . .	18	Common Spare Parts . . . . .	57
Adjust Abrasive Media . . . . .	19	Other Accessories . . . . .	57
Use the Water Dose Meters . . . . .	20	<b>Dimensions</b> . . . . .	<b>60</b>
Refill Pot with Media . . . . .	20	EcoQuip 2 EQs Dual Line with Water Tank . . . . .	60
Setting the Abrasive Metering Valve . . . . .	20	EcoQuip 2 EQs Dual Line . . . . .	60
Optimizing the Abrasive Metering Valve . . . . .	21	EcoQuip 2 EQc Dual Line . . . . .	61
General Application Guides . . . . .	22	<b>Technical Specifications</b> . . . . .	<b>62</b>
Nozzle Selection Guide . . . . .	23	<b>California Proposition 65</b> . . . . .	<b>62</b>
Use the Wash Feature . . . . .	24	<b>Graco Standard Warranty</b> . . . . .	<b>64</b>

## Related Manuals

Manual in English	Description
3A6844	Stainless Steel 10:1 Pump
3A6845	Stainless Steel Lower
3A6846	Externally Piloted Air Motor
<b>Accessories</b>	
313840	DataTrak® Kits
309474	Low Pressure Fluid Regulators
3A3839	Handle Kit for EcoQuip 2 Vapor Abrasive Blast Systems
306715	Water Dispense Valve

# Models

Model	System	Blast Control		Approvals
		Pneumatic	Electric	
EQs DL with water tank	282960	✓	✓	CE
	282961	✓		CE  II 2 G Ex ia h IIA T3 Gb X
EQs DL	282950	✓	✓	CE
	282951	✓		CE  II 2 G Ex ia h IIA T3 Gb X
EQc DL	282500	✓	✓	CE
	282501	✓		CE  II 2 G Ex ia h IIA T3 Gb X

# Packages









**NOTE:** All packages include:

- blast control switches (pneumatic or electric)
- two Graco #8 High Performance blast nozzles
- either 200 ft of 1.25 in. ID blast hose (pneumatic packages) or 300 ft of 1.25 in ID blast hose (electric packages)

Model	Package	Included System	Blast Control	
			Pneumatic	Electric
EQs DL with water tank	282962	282960	✓	
	282963			✓
	282964	282961	✓	
EQs DL	282952	282950	✓	
	282953			✓
	282954	282951	✓	
EQc DL	282502	282500	✓	
	282503			✓
	282504	282501	✓	

# Warnings

The following warnings are for the setup, use, grounding, maintenance, and repair of this equipment. The exclamation point symbol alerts you to a general warning and the hazard symbols refer to procedure-specific risks. When these symbols appear in the body of this manual or on warning labels, refer back to these Warnings. Product-specific hazard symbols and warnings not covered in this section may appear throughout the body of this manual where applicable.

 <h1 style="margin: 0;">WARNING</h1>	
 	<p><b>SPECIAL CONDITIONS FOR SAFE USE (ATEX systems only)</b></p> <ul style="list-style-type: none"> <li>• Ground all equipment in the work area. See <b>Grounding (ATEX systems only)</b> Instructions.</li> <li>• All label and marking material must be cleaned with a damp cloth (or equivalent).</li> </ul>
 	<p><b>DUST AND DEBRIS HAZARD</b></p> <p>Use of this equipment can result in the release of potentially harmful dust or toxic substances from the abrasive being used, the coatings being removed, and the base object being blasted.</p> <ul style="list-style-type: none"> <li>• For use only by sophisticated users familiar with applicable governmental safety and industrial hygiene regulations.</li> <li>• Use equipment only in a well-ventilated area.</li> <li>• Wear a properly fit-tested and government approved respirator suitable for the dust conditions.</li> <li>• Follow local ordinances and/or regulations for disposal of toxic substances and debris.</li> </ul>
  	<p><b>PRESSURIZED EQUIPMENT HAZARD</b></p> <p>Fluid from the equipment, leaks, or ruptured components can splash in the eyes or on skin and cause serious injury.</p> <ul style="list-style-type: none"> <li>• Follow the <b>Pressure Relief Procedure</b> when you stop spraying/dispensing and before cleaning, checking, or servicing equipment.</li> <li>• Tighten all fluid connections before operating the equipment.</li> <li>• Check hoses, tubes, and couplings daily. Replace worn or damaged parts immediately.</li> </ul>

# ! WARNING



## EQUIPMENT MISUSE HAZARD

Misuse can cause death or serious injury.

- Do not operate the unit when fatigued or under the influence of drugs or alcohol.
- Do not exceed the maximum working pressure or temperature rating of the lowest rated system component. See in the equipment manuals.
- Do not use this equipment without hose restraints and coupler pins installed on all air and blast hose couplings.
- Do not blast unstable objects. The high amount of fluid flow from the nozzle can potentially move heavy objects.
- Do not exceed load ratings of lift eyes.
- Do not operate equipment on or stand on an unstable support. Keep effective footing and balance at all times.
- Use fluids and solvents that are compatible with equipment wetted parts. See in all equipment manuals. Read fluid and solvent manufacturer's warnings. For complete information about your material, request Safety Data Sheets (SDSs) from distributor retailer.
- Never use 1, 1, 1-trichloroethane, methylene chloride, other halogenated hydrocarbon solvents or fluids containing such solvents in pressurized aluminum equipment. Such use could result in a chemical reaction, with the possibility of explosion.
- Do not leave the work area while equipment is energized or under pressure.
- Turn off all equipment and follow the **Pressure Relief Procedure** when equipment is not in use.
- Check equipment daily. Repair or replace worn or damaged parts immediately with genuine manufacturer's replacement parts only.
- Do not alter or modify equipment. Alterations or modifications may void agency approvals and create safety hazards.
- Make sure all equipment is rated and approved for the environment in which you are using it.
- Use equipment only for its intended purpose. Call your distributor for information.
- Route hoses and cables away from traffic areas, sharp edges, moving parts, and hot surfaces.
- Do not kink or over bend hoses or use hoses to pull equipment.
- Keep children and animals away from work area.
- Comply with all applicable safety regulations.



## BURN HAZARD

Equipment surfaces and fluid that is heated can become very hot during operation. To avoid severe burns:

- Do not touch hot fluid or equipment.







## FIRE AND EXPLOSION HAZARD

Flammable fumes, such as solvent, in work area can ignite or explode. To help prevent fire and explosion:

- Use equipment only in well ventilated areas.
- Abrasive material exiting blast nozzle can generate sparks. When flammable liquids are used near the blast nozzle or for flushing or cleaning, keep the blast nozzle at least 20 feet (6 meters) away from explosive vapors.
- Ground all equipment in the work area. See **Grounding (ATEX systems only)** instructions (ATEX systems only).
- Keep work area free of debris, including solvent, rags and gasoline.
- Keep a working fire extinguisher in the work area.

# **WARNING**

 	<p><b>MOVING PARTS HAZARD</b></p> <p>Moving parts can pinch, cut or amputate fingers and other body parts.</p> <ul style="list-style-type: none"> <li>• Keep clear of moving parts.</li> <li>• Do not operate equipment with protective guards or covers removed.</li> <li>• Equipment can start without warning. Before checking, moving, or servicing equipment, follow the <b>Pressure Relief Procedure</b> and disconnect all power sources.</li> </ul>
	<p><b>PERSONAL PROTECTIVE EQUIPMENT</b></p> <p>Wear appropriate protective equipment when in the work area to help prevent serious injury, including eye injury, hearing loss, inhalation of toxic fumes, and burns. Protective equipment includes but is not limited to:</p> <ul style="list-style-type: none"> <li>• Protective eyewear and hearing protection</li> <li>• Protective clothing, shoes and gloves</li> <li>• Properly fit-tested and government approved respirator suitable for the dust conditions</li> </ul>
	<p><b>RECOIL HAZARD</b></p> <p>Blast nozzle may recoil when triggered. If you are not standing securely, you could fall and be seriously injured.</p>



# Component Identification

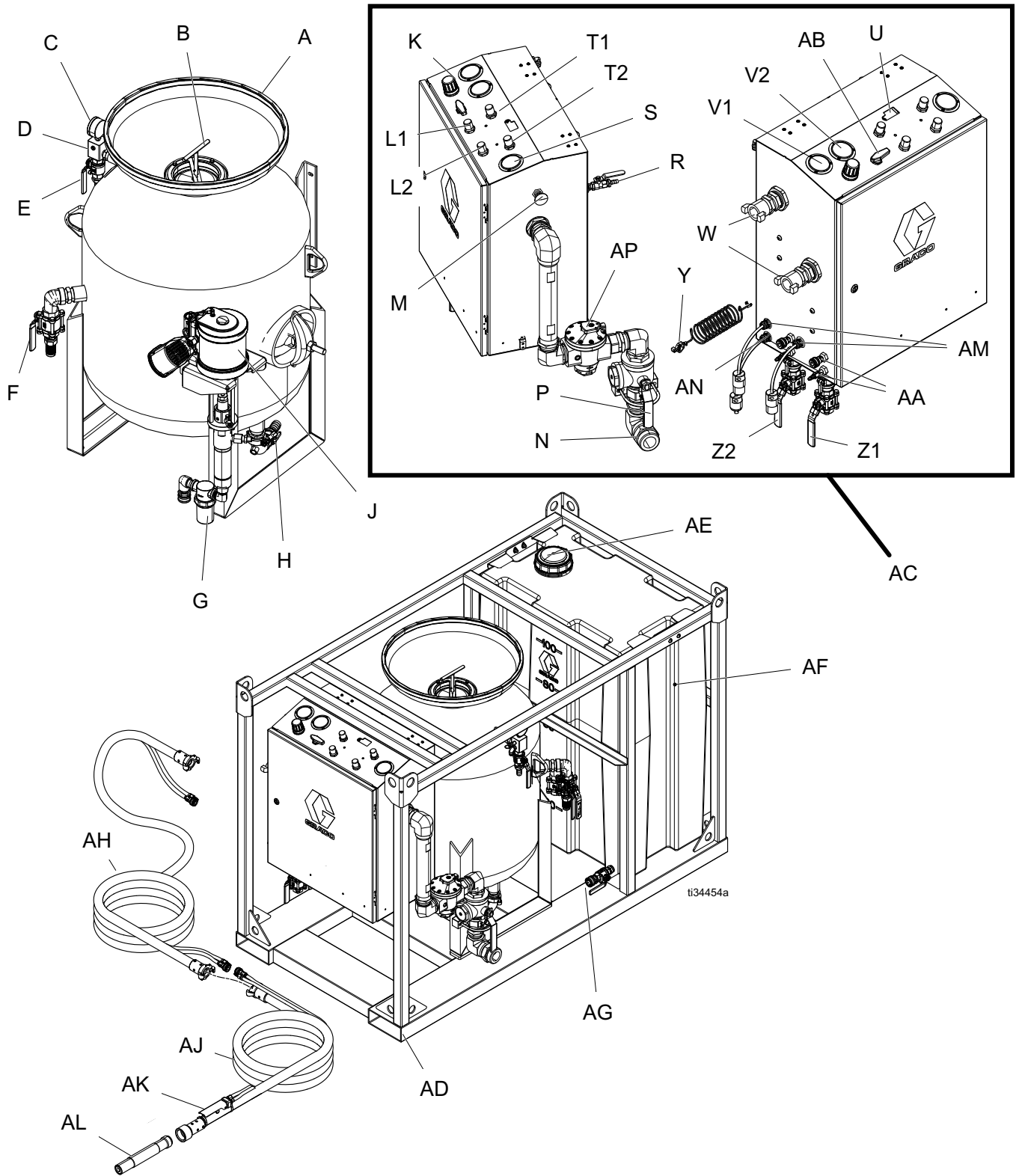


FIG. 1



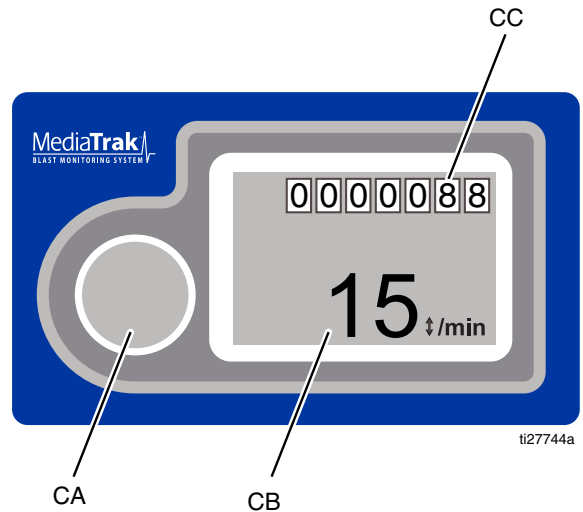
**Key:**

- A Pot
- B Pot Seal Plunger
- C Pot Pressure Gauge
- D Pressure Relief Valve
- E Pot Dump Valve
- F Quick Drain Valve
- G **Dual Line Systems with Water Tank:**  
Water Pump Inlet Filter
- Dual Line Systems without Water Tank:**  
Water Pressure Regulator
- H Abrasive Media Outlet
- J Water Pump
- K Blast Air Regulator
- L1 Water Dose Metering Valve (Nozzle 1)
- L2 Water Dose Metering Valve (Nozzle 2)
- M Emergency Stop
- N Supply Air Connection
- P Supply Air Shutoff Valve
- R Rinse Ball Valve
- S Supply Pressure Gauge
- T1 Abrasive Metering Valve (Nozzle 1)
- T2 Abrasive Metering Valve (Nozzle 2)
- U MediaTrak
- V1 Blast Air Pressure Gauge (Nozzle 1)
- V2 Blast Air Pressure Gauge (Nozzle 2)
- W Blast Hose Connection
- Y Ground Wire and Clamp (ATEX systems only)
- Z1 Abrasive Ball Valve (Nozzle 1)
- Z2 Abrasive Ball Valve (Nozzle 2)
- AA Pneumatic Control Connection
- AB Selector Valve
- AC Control Box
- AD Frame

**Key:**

- AE Water Tank Lid
- AF Water Tank
- AG Water Tank Valve
- AH Extension Hose
- AJ Blast Hose
- AK Blast Control Switch
- AL Blast Nozzle
- AM Electric Control Connection (non-ATEX systems only)
- AN Electric Input Connection
- AP Main Air Regulator

**MediaTrak Controls**






**FIG. 2**

**Key:**

- CA Power Key
- CB Cycle/Rate
- CC Grand Totalizer

# Installation

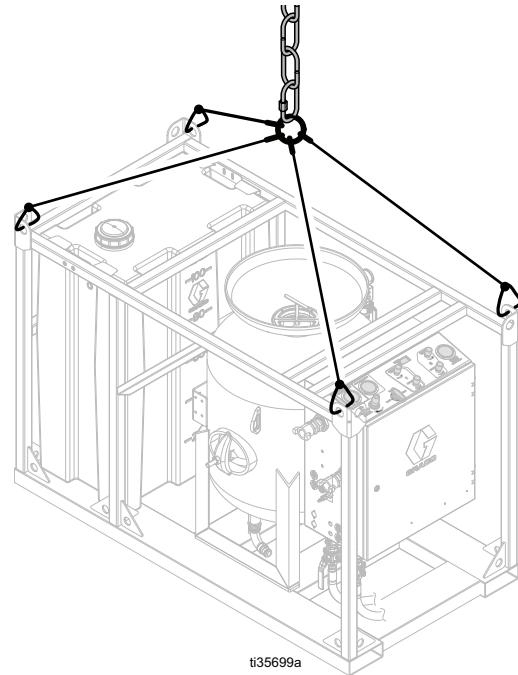
## Grounding (ATEX systems only)

				
<p>The equipment must be grounded to reduce the risk of static sparking. Static sparking can cause fumes to ignite or explode. Grounding provides an escape wire for the electric current.</p>				

**System:** use supplied ground wire and clamp (237686).

**Air and fluid hoses:** use only genuine Graco conductive blast hoses with a maximum of 150 ft (45 m) combined blast hose length to ensure grounding continuity. Check the electrical resistance of the blast hoses. If the total resistance to ground exceeds 29 megaohms, replace the blast hose immediately.

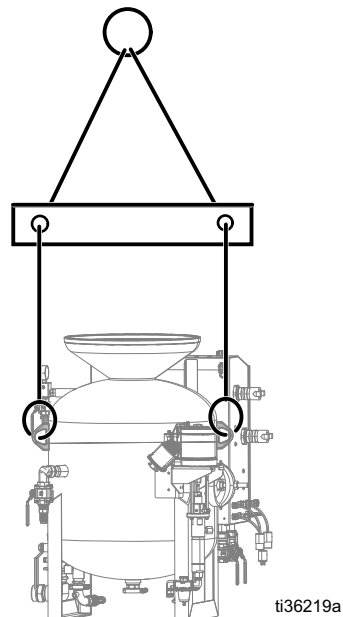
**Air compressor:** follow manufacturer's recommendations.



**FIG. 3: Use All Lift Rings on EQs Frame**

## Lifting the System

- Only lift the system using all available lift points. During an EQs system lift, the lift chains must be angled at least 45° from the horizontal.
- Before lifting the system, drain the water tank and pot of water and media.
- Lift the system with a lift apparatus rated appropriately for the weight of the system. See **Technical Specifications**, page 62.
- Lift the system using the lift eyes shown on the appropriate illustration.



**FIG. 4: Use All Lift Points on EQc**

## Select Blast Hose Control

The type of blast hose control depends on the length of blast hose needed. Use this table to select the correct blast hose control.

Hose Length	Blast Hose Control
Less than 150 ft (45 m)	Electric or pneumatic blast control switch
Greater than 150 ft (45 m)	Electric blast control switch

## Blasting on Higher Surfaces

### NOTICE

When blasting on a surface higher than the equipment, make sure that there is a length of blast hose on the ground equal to 10-20% of the height. The hose on the ground prevents unspent abrasive in the hose from backing up into the internal plumbing of the panel, which can cause damage to the main air regulator when the blast switch is disengaged.

For example, when blasting 50 vertical feet (15 vertical meters) above the system, place at least 10 ft. (3 m) of blast hose on the ground, before the blast hose rises to the blasting height.

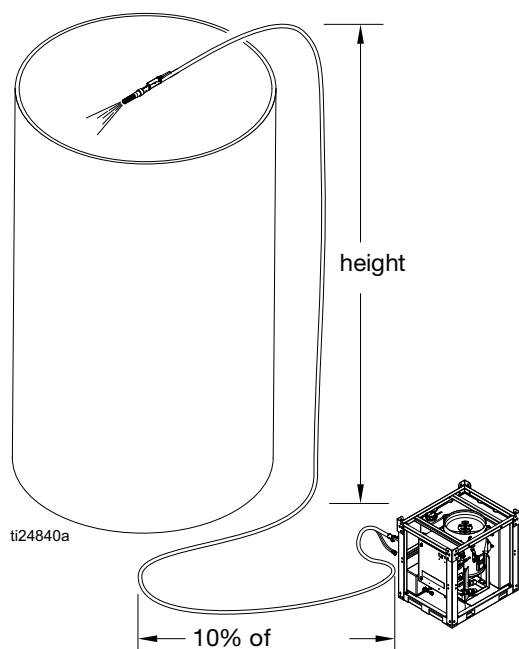


FIG. 5

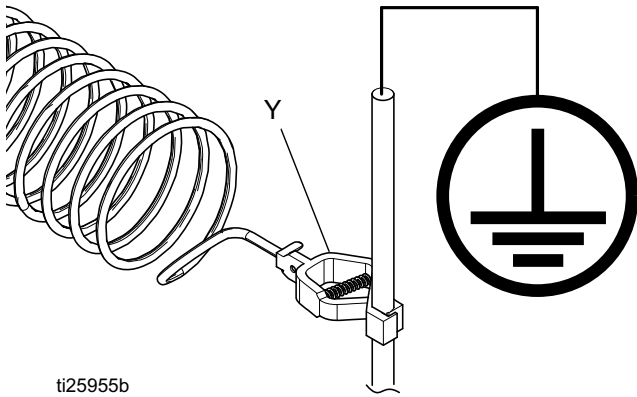
## Inspect Pinch Hoses

Inspect both pinch hoses at the start of each job or monthly, looking for “bubbles” in the outer casing. If bubbles are found in the casing, replace the pinch hose. Keep a spare pinch hose on the job site in case of hose failure.

**NOTE:** Two main factors can impact (diminish) the life of a pinch hose: abrasive media used (coarse/sharp) and blast control switch trigger rate (high).

## Connect Blast Hoses and Supply Air Hose

1. **ATEX models only:** Connect the grounding wire and clamp (Y) to the external ground stud on the enclosure. Then connect the clamp to a true earth ground.

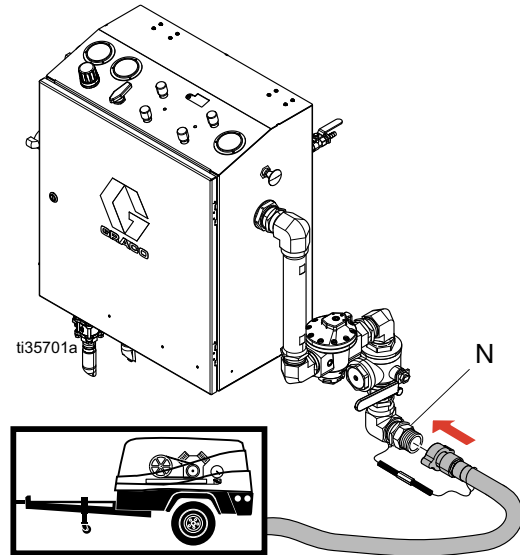


**FIG. 6: Connecting the Grounding Cable**



2. Purge the compressor hose for 15-20 seconds before connecting the air supply hose from the compressor (or on-site compressed air source) to the panel. Make sure all debris is cleared from the hose.

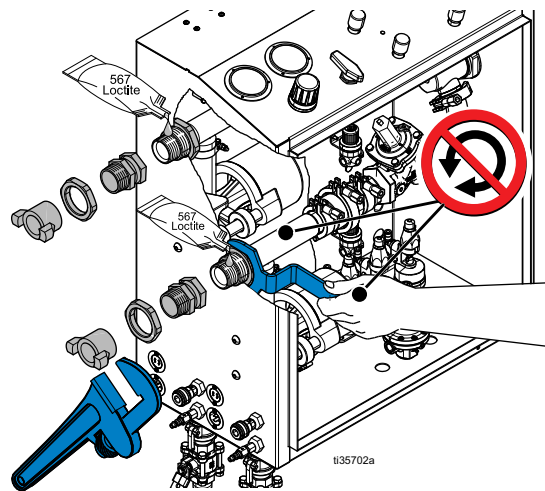
3. Connect an appropriately sized air compressor hose to the supply air connection (N). Install the hose restraint.



**FIG. 7: Connect the Air Supply Hose and Air Inlet**




### NOTICE

If the blast circuit is allowed to rotate, damage to the tubing connections on the blast control may occur. To avoid damage, use the supplied wrench to hold the blast circuit nut inside the enclosure while installing fittings to the air inlet and blast hose connections.



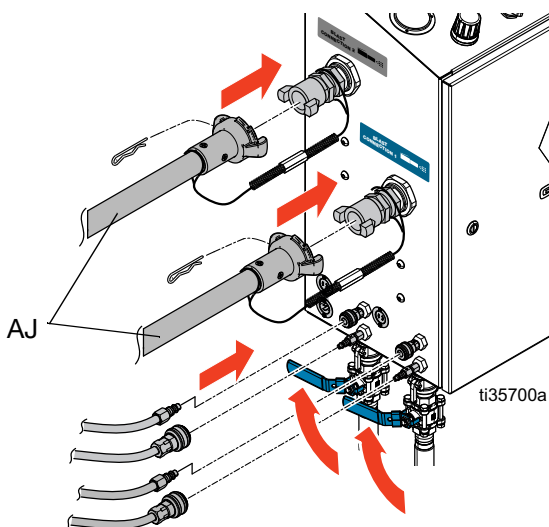
- Open the air supply valve on your compressor. The maximum compressor supply is 150 psi (10.3 bar, 1.03 MPa).

**NOTE:** Ensure the air supply meets the appropriate air flow requirements. See , page 61.

				
---	---	---	--	--

Failure to fully secure the blast hoses may cause hoses to detach during operation. To help prevent serious injury from flying debris, always install the blast hose restraints and coupler pins.

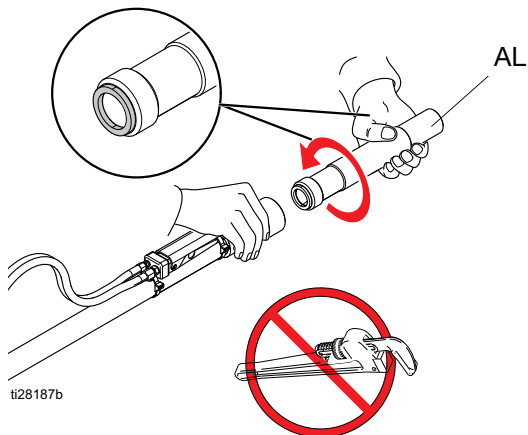
- Connect the blast hoses (AJ), hose restraints, blast control connections, and coupler pins. See Fig. 8.



**FIG. 8: Connect Hoses, Restraints, and Pins**

**NOTICE**

To avoid damage to the seal, always hand-tighten the nozzle (AL). Do not use a wrench to install the nozzle.



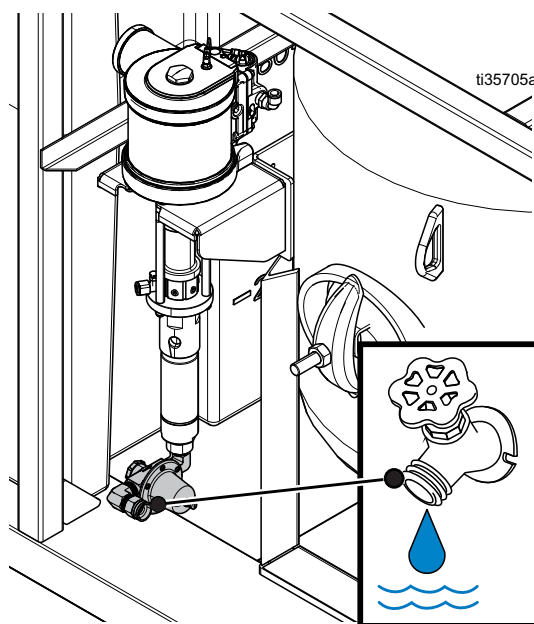
## Connect the Water Supply



### Connect the Water Hose

**NOTE:** Only connect the water hose for EQs Dual Line and EQc Dual Line systems without water tanks.

Connect a water supply hose with a minimum ID of 3/4 in. (19 mm) to the garden hose connection on the pump inlet.



**FIG. 9: Connect Water Supply Hose**

**NOTE:** The maximum water supply pressure is 100 psi (6.8 bar, 0.68 MPa). The minimum flow requirement is 3 gpm (11 lpm).

### Connect a Third-Party Water Tank

- Remove the water pressure regulator (G) from the water pump inlet. See **Component Identification**, page 8.
- Replace the regulator with the water pump inlet filter supplied in the EcoQuip 2 Dual Line toolbox.

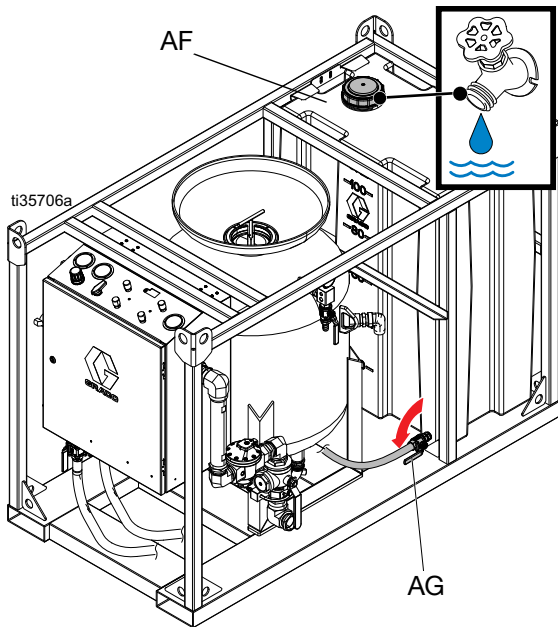
**NOTE:** The filter has 3/4 in. npt female threading.

- Connect your non-Graco water tank to the water pump inlet filter.

# Setup

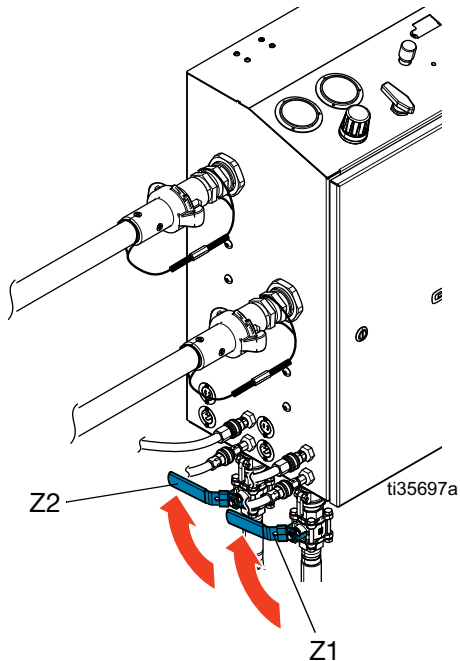
## Fill the Water Tank

1. Fill the water tank (AF) with fresh water.
2. Open the water tank valve (AG).



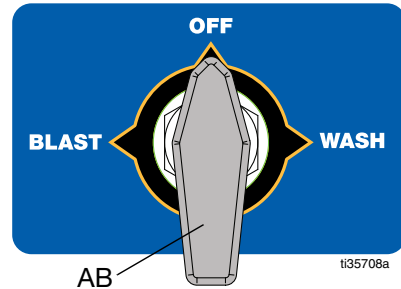
**FIG. 10: Open the Water Tank Valve**

3. Close the rinse ball valve (R) and abrasive ball valves (Z1, Z2).



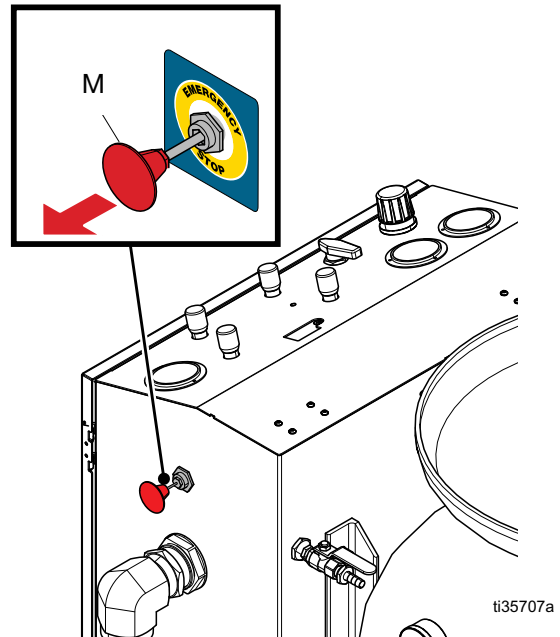
**FIG. 11: Close the Valves**

4. Turn the selector valve (AB) to OFF.



**FIG. 12: Turn the Selector Valve Off**

5. Disengage the Emergency Stop (M).



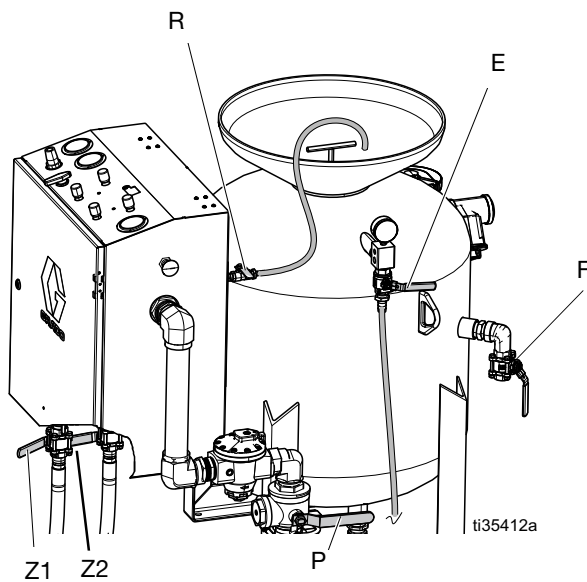
**FIG. 13: Disengage the Emergency Stop**

**NOTE:** The water pump will only function when the Emergency Stop is disengaged.

## Fill Pot with Abrasive Media

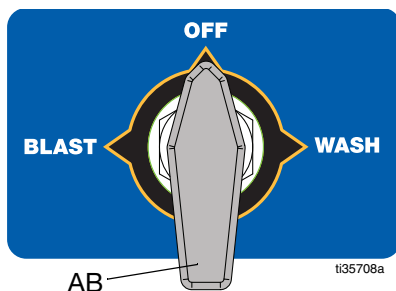


1. Verify that the pot seal plunger (B) is in the DOWN position. If the plunger is in the up position, perform the **Pressure Relief Procedure**. See page 17.
2. Verify that **Installation**, page 10, is complete.
3. Close the rinse ball valve (R) and the abrasive ball valves (Z1, Z2).
4. Open the pot dump valve (E).



**FIG. 14: Open the Pot Dump Valve**

5. Turn the selector valve (AB) to OFF.

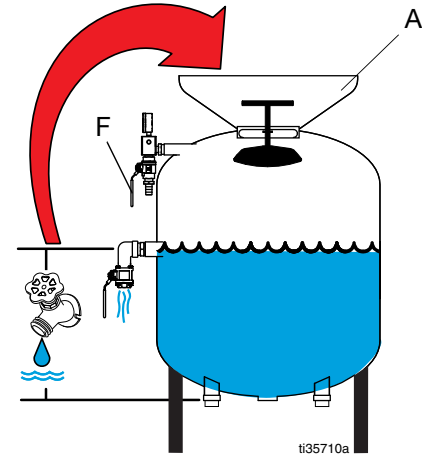


**FIG. 15: Turn the Selector Valve Off**

6. Open the quick drain valve (F).

7. Prepare the pot to accept media:

- **To fill an empty pot:** Fill approximately half the pot (A) with water, until the water drains from the quick drain valve (F). Shut the quick drain valve.
- **To refill the pot during operation:** open the quick drain valve (F) to drain the water until the pot is approximately half full. Shut the quick drain valve.

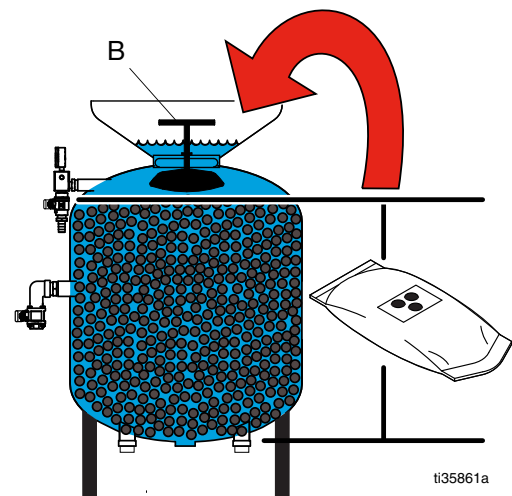


**FIG. 16: Fill the Pot**

8. Add abrasive media to the pot.

**NOTE:** The media level should be a few inches below the pot seal plunger (B). Do not overfill the pot with abrasive material, or the pot seal plunger will not be able to seal.

**NOTE:** As long as the abrasive media is below the plunger, the water level can rise above the pot seal plunger (B) without affecting performance.

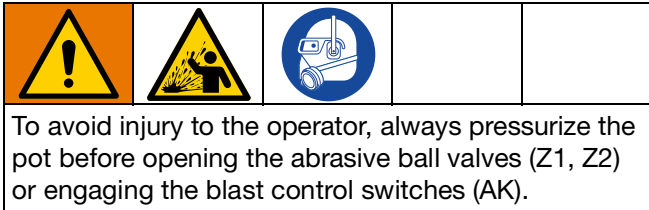


**FIG. 17: Add Abrasive Media**

## Setup

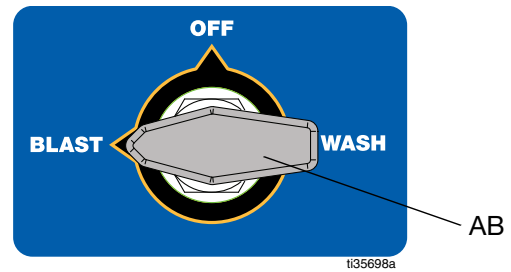
9. **For systems with water tank only:** If the water tank (AF) is less than halfway full, fill the tank with fresh water.
10. With a garden hose or the rinse valve (R), wash the abrasive into the pot and clear any abrasive from the pot seal plunger (B) and pot seal plunger gasket.
11. Close the pot dump valve (E).
12. Fill the pot with water until the water level is above the pot seal plunger (B).

## Pressurize the Pot



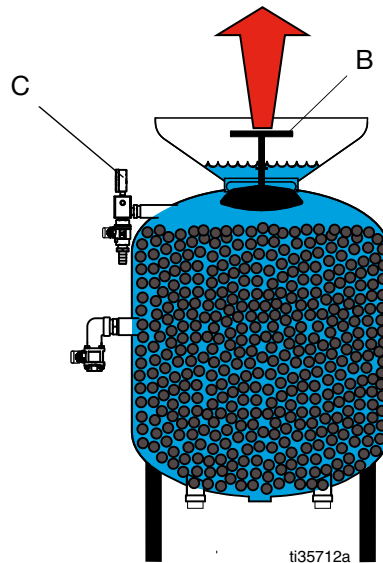
1. Verify that the pot seal plunger (B) is in the down position and the top of the plunger is clean of abrasive media.
2. Verify that the rinse ball valve (R), abrasive ball valves (Z1, Z2), the pump dump valve (E), and the quick drain valve (F) are all shut.
3. Verify that the water level in the pot (A) is above the pot seal plunger (B).

4. Turn the selector valve (AB) to BLAST.



**FIG. 18: Turn the Selector Valve to Blast**

5. Pull upwards on the pot seal plunger (B). Hold until the pot pressure on the pot pressure gauge (C) rises to 185 psi. The pressure holds the pot seal plunger in place.



**FIG. 19: Add Abrasive Media**

6. Verify that the pressure on the pot pressure gauge (C) has risen above 170 psi.



# Operation

<p>This equipment may introduce dust and debris into the air. To help prevent serious injury from flying debris, always wear personal protective equipment while operating the equipment.</p>				

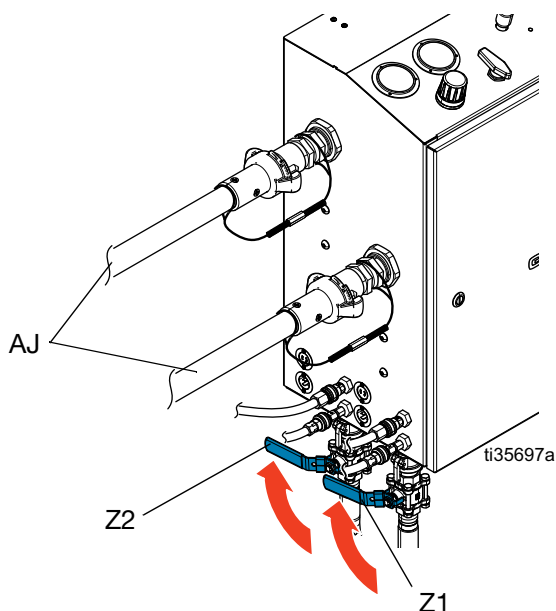
## Pressure Relief Procedure

Follow the Pressure Relief Procedure whenever you see this symbol.

<p>This equipment stays pressurized until pressure is manually relieved. To help prevent serious injury from pressurized fluid, splashing fluid and moving parts, follow the Pressure Relief Procedure when you stop spraying and before cleaning, checking, or servicing the equipment.</p>				

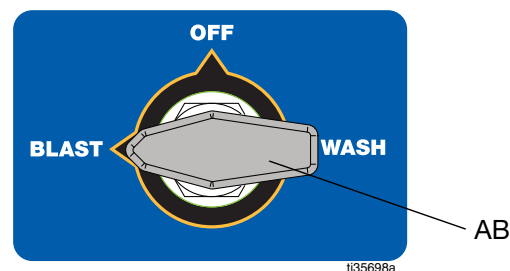
1. Close both of the abrasive ball valves (Z1, Z2).

**NOTE:** If the abrasive ball valves are not closed when the supply air is shut off, gravity will cause abrasive media and water to drain from the pot (A) into the blast hose (AJ).



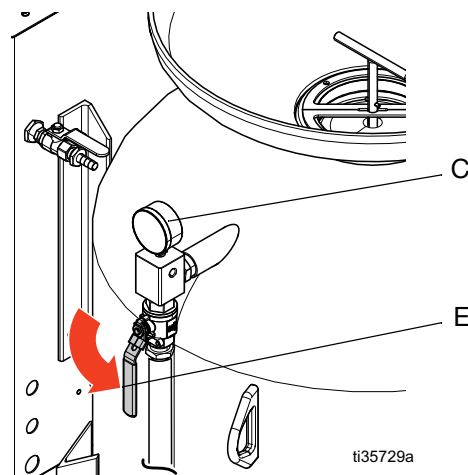
**FIG. 20: Close Ball Valves**

2. Close the supply air shutoff valve (P) and the compressor air valve, then turn the compressor off.
3. Engage the emergency stop (M).
4. Trigger both blast control switches (AK) to relieve pressure in the system.
5. Verify that the supply pressure gauge (S) reads 0 psi. Then disconnect the supply air hose from the system. See FIG. 1, page 8.
6. Turn the selector valve (AB) to BLAST.



**FIG. 21: Turn Selector Valve to Blast**

7. Open the pot dump valve (E) until the pot pressure gauge (C) reads 0 psi.



**FIG. 22: Open Pot Dump Valve**

8. Close the pot dump valve (E). Turn the selector valve (AB) to OFF.

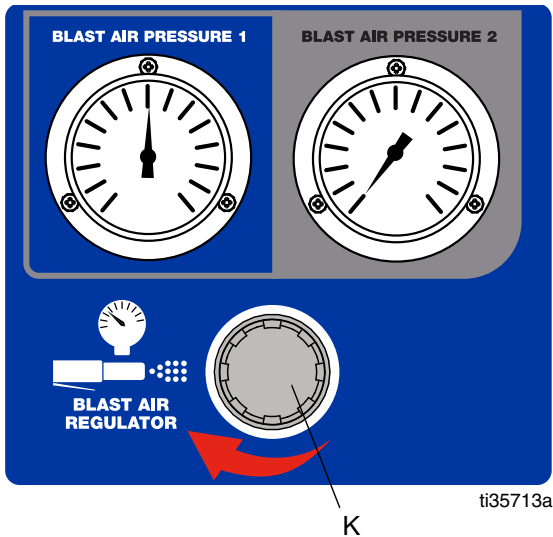
## Adjust Blast Pressure



To avoid injury due to a spray of wet media from the pot, always **Pressurize the Pot** before opening the abrasive ball valves (Z1, Z2) and engaging the blast control switches (AK).

1. **Fill Pot with Abrasive Media.** See page 15.
2. **Pressurize the Pot.** See page 16.
3. Trigger blast control switch 1 (AK).
4. Adjust the blast air regulator (K) until the desired pressure appears on the blast pressure gauge (V).

**NOTE:** The blast air pressure is the same for both air nozzles. The blast air pressure is determined by the blast air regulator (K) setting. The minimum blast air regulator setting is 50 psi.



**FIG. 23: Adjust the Supply Air Regulator**

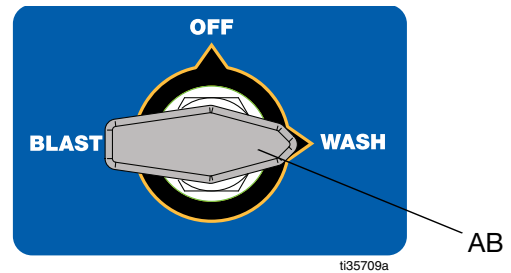
5. Disengage blast control switch 1 (AK).

## Wet the Internal Water Lines

### NOTICE

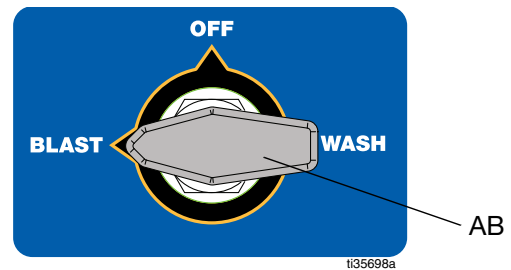
The EcoQuip 2 Dual Line system is shipped with dry water lines. Before you **Adjust Abrasive Media**, fill the internal water lines with water to prevent media entering the water lines.

1. **Adjust Blast Pressure**, page 18.
2. Turn the selector valve (AB) to WASH.



**FIG. 24: Turn the Selector Valve to Wash**

3. Trigger blast control switches 1 and 2 (AK) for at least 10 seconds to allow the internal water lines to fill with water.
4. Disengage blast control switches 1 and 2 (AK).
5. Turn the selector valve (AB) to BLAST.

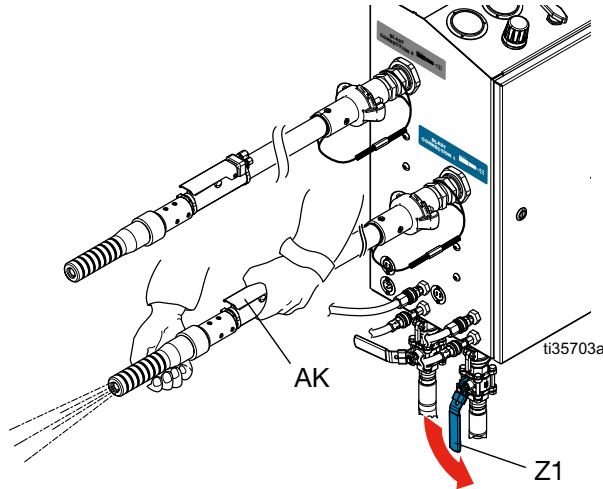


**FIG. 25: Turn the Selector Valve to Blast**

6. Open the water dose metering valves (L1, L2).
7. Trigger blast control switches 1 and 2 (AK) for at least 10 seconds to allow the internal water lines to fill with water.
8. Disengage blast control switches 1 and 2 (AK).
9. Shut the water dose metering valves (L1, L2).

## Adjust Abrasive Media

1. **Adjust Blast Pressure**, page 18.
2. **Wet the Internal Water Lines**, page 18.
3. Open the nozzle 1 abrasive media ball valve (Z1). Trigger the nozzle 1 blast control switch (AK).

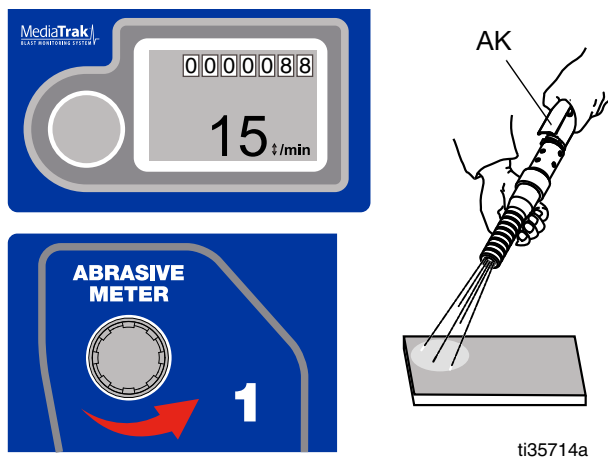


**FIG. 26: Open the Ball Valve**

4. Turn on the Media Trak display (CA). See FIG. 2.
5. Slowly adjust the nozzle 1 abrasive meter valve (T1) to the desired flow of abrasive media.

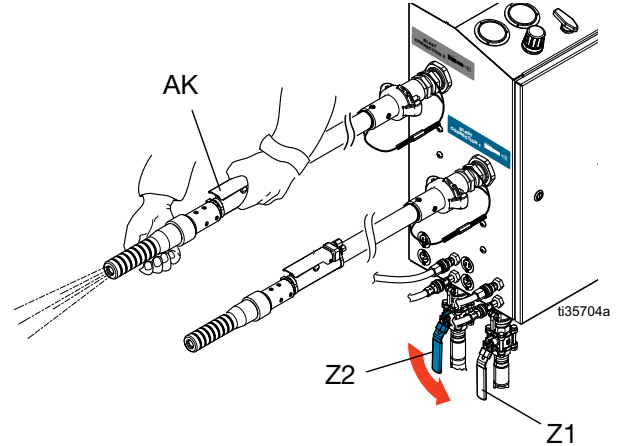
**NOTE:** You may have to wait 1-2 minutes for the abrasive material to reach the nozzle.

**NOTE:** Test the abrasive media flow on a piece of test material similar to what you will be blasting. Always start as gently as possible. Increase the blast pressure as necessary to clean without damaging the substrate.



**FIG. 27: Adjust the Abrasive Meter Valve**

6. Disengage the nozzle 1 blast control switch (AK). Wait 5 seconds to allow the pot to re-pressurize.
7. Open the abrasive media ball valve (Z2) for nozzle 2. Trigger the nozzle 2 blast control switch (AK).



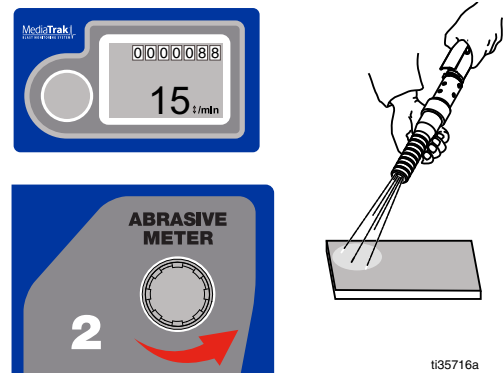
**FIG. 28: Open the Ball Valve**

8. Slowly adjust the nozzle 2 abrasive meter valve (T2) until the nozzle 2 flow rate displayed on the MediaTrak matches the flow rate for nozzle 1.

**NOTE:** To achieve a consistent and reliable abrasive media flow rate for each nozzle, the abrasive media flow rates for both nozzles must be the same.

**NOTICE**

To prevent equipment damage in the event that supply air pressure or pot pressure is lost, close both abrasive media ball valves (Z1, Z2) when not blasting for extended periods of time.



**FIG. 29: Adjust the Abrasive Meter Valve**

## Use the Water Dose Meters

1. **Wet the Internal Water Lines**, page 18.
2. Trigger blast control switch 1 (AK).
3. Adjust the water dose meter valve to select the desired blast wetness. Once the desired blast wetness is reached, check the MediaTrak cycle count.
4. Disengage blast control switch 1 (AK). Wait five seconds to allow the pot to pressurize.
5. Trigger blast control switch 2 (AK). Check the MediaTrak cycle count.
6. Adjust the water dose meter valve until the MediaTrak cycle count matches the setting in step 3.

**NOTE:** The MediaTrak cycle count rates for both nozzles must match. Matching cycle counts ensures a consistent, reliable flow rate for wet abrasive media from both nozzles.

## Refill Pot with Media

1. As abrasive media leaves the pot during blasting, **Fill Pot with Abrasive Media**, page 15.

**NOTE:** If the pot loses pressure, **Pressurize the Pot**, page 16.

## Setting the Abrasive Metering Valve

The optimal setpoint of the abrasive metering valve and corresponding MediaTrak CPM value varies significantly depending on application and user-desired performance. The **General Application Guides**, page 22, describe the generally accepted range of CPM setpoints based on the substrate and blast pressure setpoint. The grey highlighted area illustrates the typical range of blast pressure setpoints and their corresponding CPM setpoints for that substrate.

To find the recommended CPM setpoint, select the table that most closely matches the substrate that is to be blasted. Determine the blast pressure setpoint based on the media that is being used and the desired surface profile to be achieved. Then, use the corresponding lines on the chart to select the appropriate CPM setpoint.

For inexperienced users, select a blast pressure near the low end of the highlighted range. Increase blast pressure and CPM until the desired profile and removal rate are achieved.

## Optimizing the Abrasive Metering Valve

To optimize performance, use the High Production or Media Efficient lines on the charts. The CPM setpoints near the High Production lines will yield the highest removal rates and the highest media consumption rates. To maximize removal rate regardless of media consumption, use the highest possible blast pressure and set the CPM to the highest achievable value that produces a consistent pattern. The CPM setpoint is too high if the flow from the nozzle starts to sputter.

CPM setpoints near the Media Efficient line will use the lowest amount of media. To minimize cleanup and media usage, use a setpoint closer to this line.

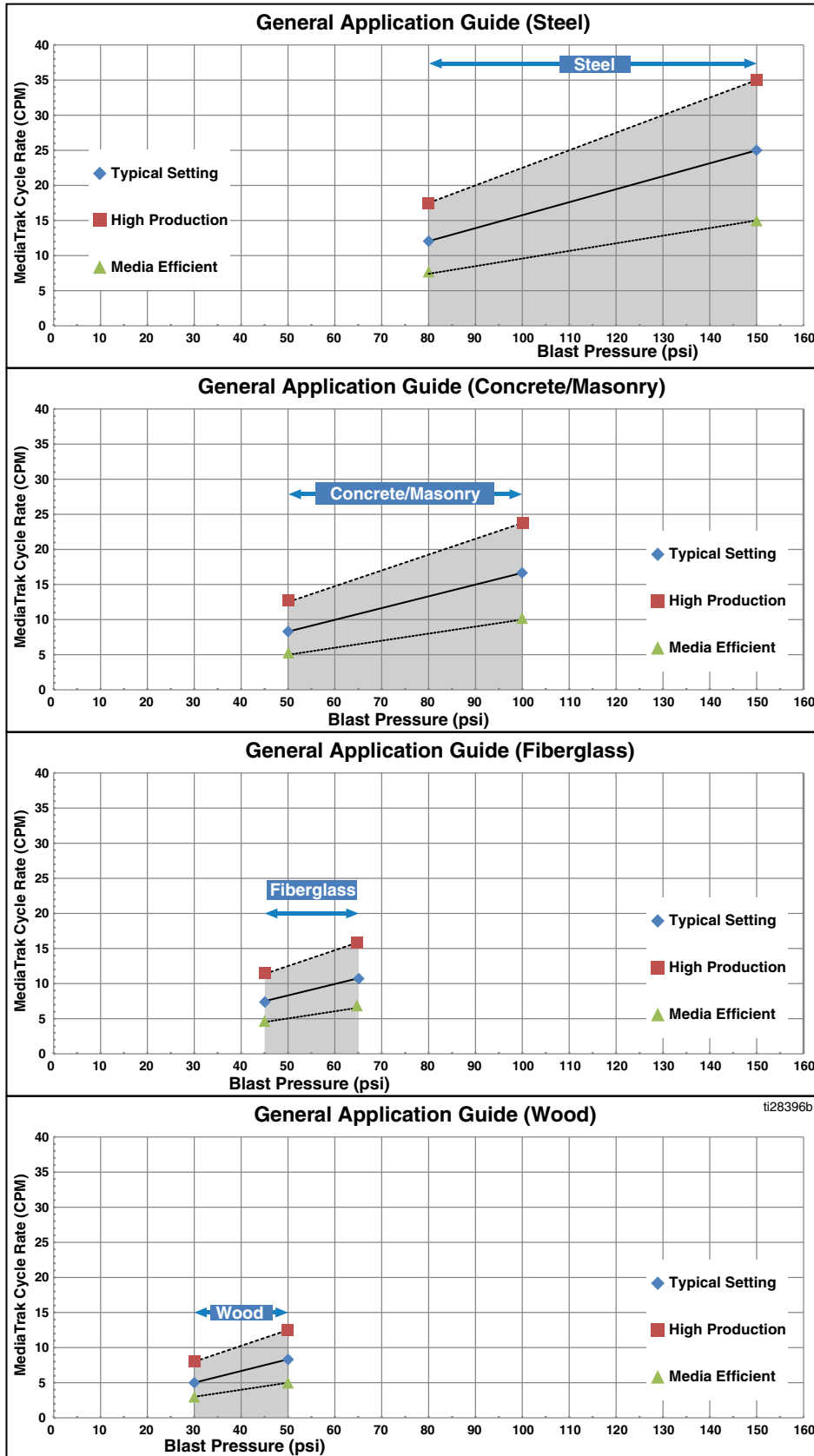
Generally, removal rates will be less than average when setting the CPM according to this line.

The general application guides are only guidelines. They were developed using garnet media in the 30-80 mesh range. Coarser media will produce a deeper profile, but will require higher CPM setpoints to yield similar removal rates to the setpoints shown in the tables. Finer media will yield higher removal rates, but will not produce as deep of a profile.

Fine-tuning and experimentation are necessary to optimize performance for each application.

See the **General Application Guides**, page 22.

# General Application Guides



## Nozzle Selection Guide

Use the Blast Pressure vs. Air Flow Guide to determine which nozzle to use to achieve the desired blast pressure based on compressor output.

### Blast Pressure vs. Air Flow Guide

**NOTE:** The air flow assumes one nozzle is in use.

Blast Pressure	#6HP CFM (m <sup>3</sup> /min)	#7 CFM (m <sup>3</sup> /min)	#7HP CFM (m <sup>3</sup> /min)	#8 CFM (m <sup>3</sup> /min)	#8HP CFM (m <sup>3</sup> /min)	#10 CFM (m <sup>3</sup> /min)	#10HP CFM (m <sup>3</sup> /min)
30 psi (2.0 bar, 0.20 MPa)	78 (2.2)	117 (3.3)	137 (3.9)	151 (4.3)	161 (4.6)	229 (6.5)	224 (6.9)
40 psi (2.8 bar, 0.28 MPa)	90 (2.5)	129 (3.7)	161 (4.6)	181 (5.1)	212 (6.0)	254 (7.2)	286 (8.1)
50 psi (3.5 bar, 0.35 MPa)	117 (3.3)	161 (4.6)	193 (5.5)	200 (5.7)	225 (6.4)	308 (8.7)	337 (9.5)
60 psi (4.1 bar, 0.41 MPa)	137 (3.9)	190 (5.4)	225 (6.4)	234 (6.6)	256 (7.2)	362 (10.3)	391 (11.1)
70 psi (4.8 bar, 0.48 MPa)	166 (4.7)	225 (6.4)	251 (7.1)	269 (7.6)	293 (8.3)	422 (11.9)	447 (12.7)
80 psi (5.5 bar, 0.55 MPa)	188 (5.3)	244 (6.9)	281 (8.0)	298 (8.3)	337 (9.5)	460 (13.0)	498 (14.1)
90 psi (6.2 bar, 0.62 MPa)	210 (5.9)	266 (7.5)	293 (8.3)	317 (9.0)	374 (10.6)	520 (14.7)	562 (16.0)
100 psi (6.9 bar, 0.69 MPa)	239 (6.8)	283 (8.0)	327 (9.3)	378 (10.7)	413 (11.7)	561 (15.9)	601 (17.0)
110 psi (7.6 bar, 0.76 MPa)	256 (7.2)	325 (9.2)	347 (9.8)	420 (11.9)	457 (12.9)	634 (18.0)	664 (18.8)
120 psi (8.3 bar, 0.83 MPa)	273 (7.7)	344 (9.7)	378 (10.7)	452 (12.8)	476 (13.5)	691 (19.6)	720 (20.4)
130 psi (9.0 bar, 0.90 MPa)	288 (8.2)	374 (10.6)	415 (11.8)	493 (14.0)	527 (16.2)	721 (20.4)	759 (21.5)
140 psi (9.7 bar, 0.97 MPa)	313 (8.9)	405 (11.5)	449 (12.7)	530 (15.0)	571 (16.2)	758 (21.5)	797 (22.6)
150 psi (10.3 bar, 1.0 MPa)	331 (9.5)	430 (12.2)	476 (13.5)	558 (15.8)	601 (17.0)	796 (22.54)	853 (23.6)

**Legend:**

< 185 CFM

185 - 375 CFM

> 375 CFM

## Use the Wash Feature



### NOTICE

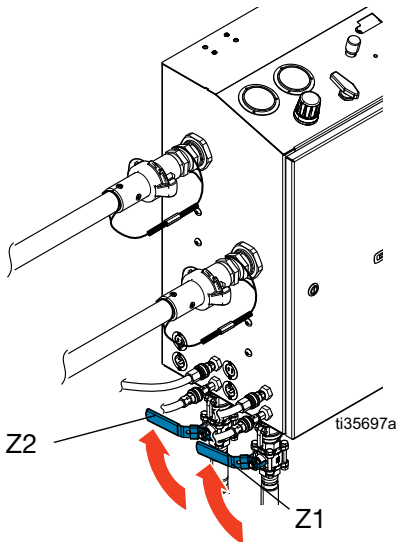
There will always be some residual abrasive in the blast hose. Never use the wash feature on any surface other than where you have blasted, or intend to blast. The wash feature could cause damage to the surface.

### NOTICE

Do not use the wash feature on wood that has been blasted. The wash feature may damage the wood and cause the grain to rise. To remove any residual abrasive from wood, wait for the wood to dry before using a broom, brush, or vacuum.

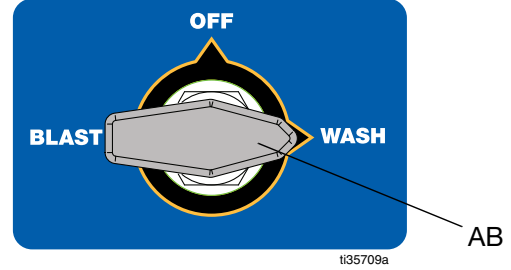
The wash feature uses water (without abrasive) to rinse areas that have been blasted with abrasive. The wash feature can also be used to flush abrasive from the blast hose.

1. Close the abrasive ball valves (Z1, Z2).



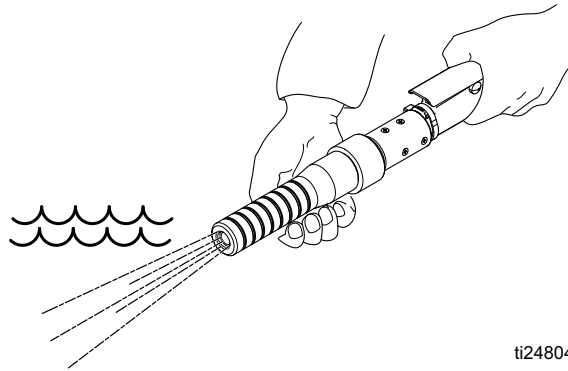
**FIG. 30: Close the Abrasive Ball Valves**

2. Turn the selector valve (AB) to WASH.



**FIG. 31: Turn the Selector Valve to Wash**

3. Blast one to two minutes on a test material. Blast until the abrasive is cleared from the hoses that were used during operation.



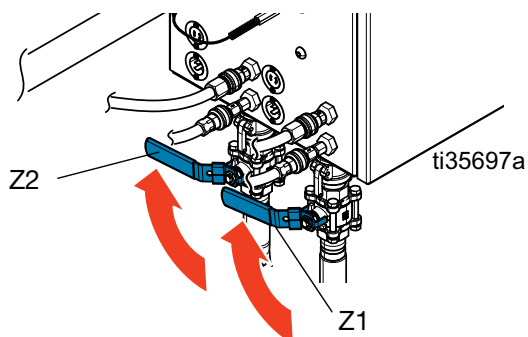
**FIG. 32: Blast on Test Material**

4. Rinse any previously blasted surfaces.



## Standby

1. Close the abrasive ball valves (Z1, Z2).

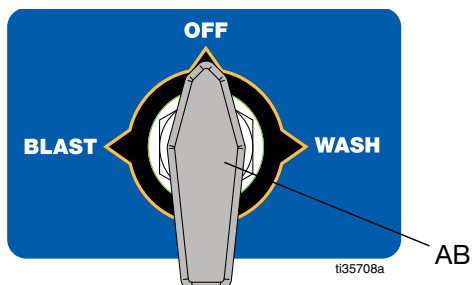


**Fig. 33: Close the Ball Valves**

### NOTICE

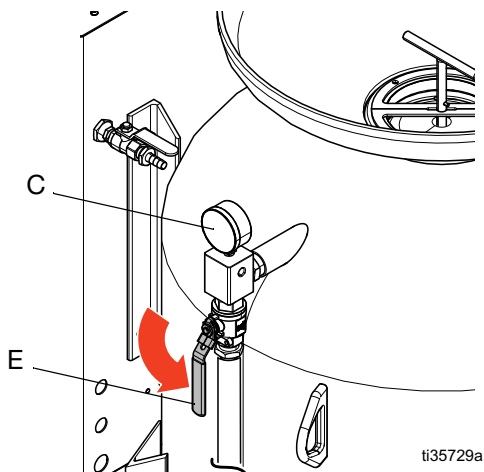
To prevent material from packing out and damaging blast hoses, do not shut off your air compressor during Standby.

2. Turn the selector valve (AB) to OFF.



**Fig. 34: Turn the Selector Valve Off**

3. Open the pot dump valve (E) until the pot pressure gauge (C) reads 0 psi.



**Fig. 35: Open Pot Dump Valve**

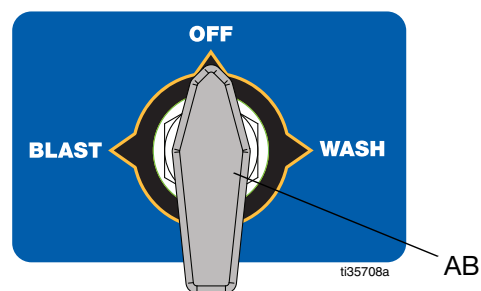
## Shutdown



### NOTICE

To prevent material from packing out and damaging blast hoses, ensure that the abrasive ball valves are fully closed before shutting off your air compressor.

1. Use the wash feature to flush all abrasive from the blast hose. See **Use the Wash Feature**, page 24.
2. Turn the selector valve (AB) to OFF.

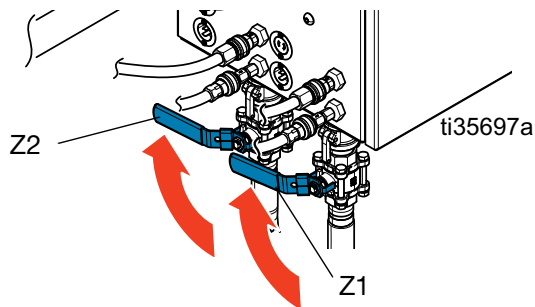


**Fig. 36: Turn the Selector Valve Off**

3. With the abrasive ball valves (Z1, Z2) closed, continue to blast until all water is cleared from the hose. This dries the inside of the hose for storage.
4. Follow the **Pressure Relief Procedure**. See page 17.

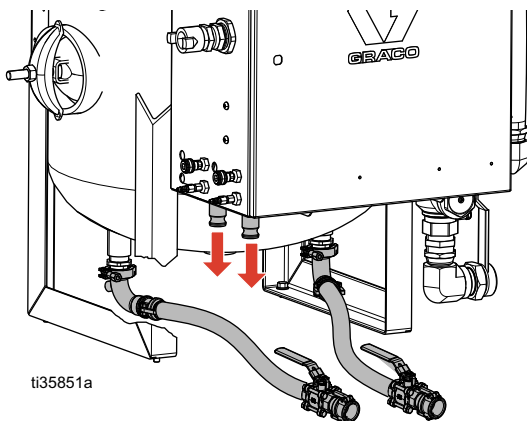
## Drain the Pot

1. Before draining the pot (A), verify that **Pressurize the Pot** has been completed. (See page 16.) Check the pot pressure gauge (C) to verify that the pot is pressurized.
2. Close the abrasive ball valves (Z1, Z2).



**FIG. 37: Close the Ball Valves**

3. Disconnect the blast control connections (AA, AM).
4. Disconnect the camlocks between the enclosure (1) and the abrasive ball valves (Z1, Z2).
  - a. Remove the coupler pins.
  - b. Pull the rings out and up to pull the two cams away from the groove.



**FIG. 38: Disconnect the Camlocks**

5. Place a bucket under the camlock couplers.

6. Turn the selector valve (AB) to WASH to run water through the camlock coupler and gasket.
7. Verify that the gasket is clean and fully installed.
8. Turn the selector valve (AB) to BLAST to pump abrasive out of the abrasive hose.
9. Place a bucket under the end of one abrasive hose.
10. To flush abrasive material from the pot, slowly open and close the abrasive ball valves (Z1, Z2). Repeat several times.
11. Once no abrasive material flows from the hose, close the abrasive ball valves (Z1, Z2).
12. Repeat the flush process with the other abrasive hose.
13. Turn the selector valve (AB) to OFF.
14. Open the abrasive ball valves (Z1, Z2) and drain the water from the pot.
15. Shut the abrasive ball valves (Z1, Z2).
16. Connect the camlocks between the enclosure (1) and the abrasive ball valves (Z1, Z2).
17. The shape of the pressure pot may allow some residual media to remain in the pot after draining. To remove all media from the pot:
  - a. Remove the handway cover on the side of the pressure pot.
  - b. Remove the pot drain clamp and cap on the bottom of the pressure pot.
  - c. Drain any residual media through the drain port in the bottom of the pressure pot.
  - d. After draining, install the pot drain clamp, pot drain cap, and handway cover.

## Winterize the Equipment

### NOTICE

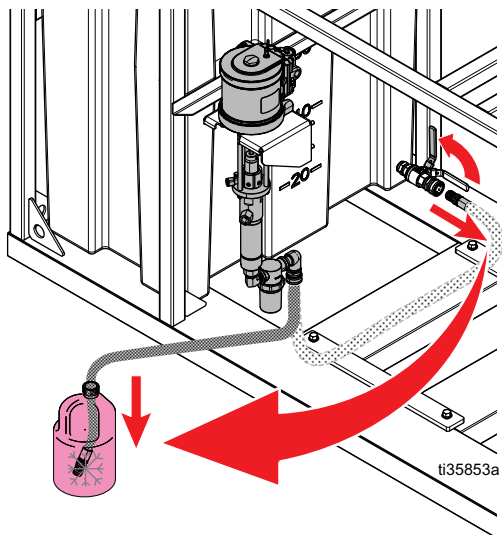
Vapor abrasive blasters must be winterized whenever there is a possibility of freezing temperatures during storage to avoid damage to the equipment.

1. **Drain the Pot.** See page 26.
2. Drain the water tank (AF). Disconnect the pump inlet hose and open the water tank valve (AG). See FIG. 39.

**NOTE:** All disposals must comply with national, state, and local regulations.

3. Drain the pump inlet hose.
4. Insert the end of the pump inlet hose into a windshield washer fluid container.

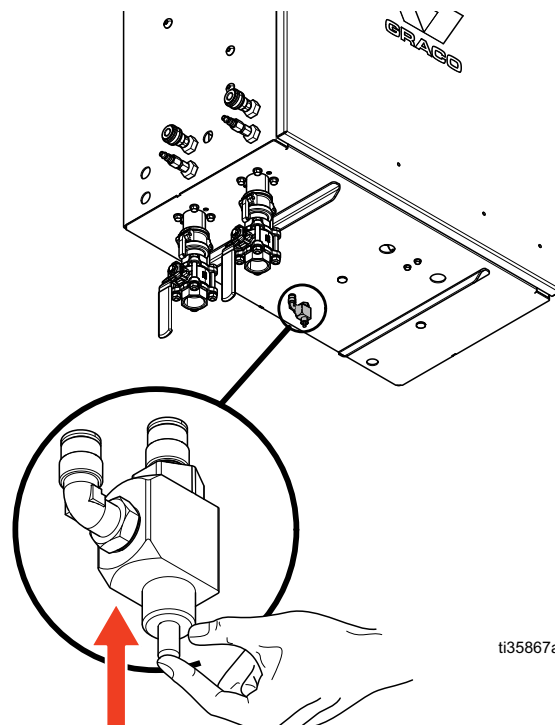
**NOTE:** Choose a windshield washer fluid with a rating that will protect the equipment for the lowest temperatures in your area.



**FIG. 39: Insert the Pump Inlet Hose**

5. **For EQ DL units without a water tank only:** Disconnect the water inlet regulator from the pump. Install the winterizing tube. Insert the winterizing tube into a windshield washer fluid container.
6. Shut both abrasive metering valves (T1, T2).
7. Shut both water dose metering valves (L1, L2).
8. Open the rinse ball valve (R) while holding the rinse hose over the pot.

9. When windshield washing fluid comes out of the rinse hose, shut the rinse ball valve (R).
10. Turn the selector valve (AB) to WASH. Verify that the internal wash tubing to both blast circuits is filled with windshield washing fluid.
11. Turn the selector valve (AB) to OFF.
12. Open both water dose metering valves (L1, L2).
13. Press the winterization button and turn the selector valve (AB) to BLAST.



**FIG. 40: Winterization Button**

14. Verify that the internal wash tubing to both blast circuits is filled with windshield washing fluid.
15. Release the winterization button, turn the selector valve (AB) to OFF, and shut both water dose metering valves (L1, L2).
16. Open both abrasive metering valves (T1, T2).
17. Press the winterization button and turn the selector valve (AB) to BLAST.
18. Verify that the internal abrasive metering tubing is filled with windshield washing fluid.
19. Release the winterization button.

20. Verify that the water tubing to the pot is filled with windshield washer fluid.

21. Turn the selector valve (AB) to OFF.

**NOTE:** All water tubing should be filled with windshield washing fluid.

22. Engage the emergency stop (M).

23. Connect the pump inlet hose to the water tank valve (AG).

24. Verify that the rinse ball valve and the water tank valve are left open.

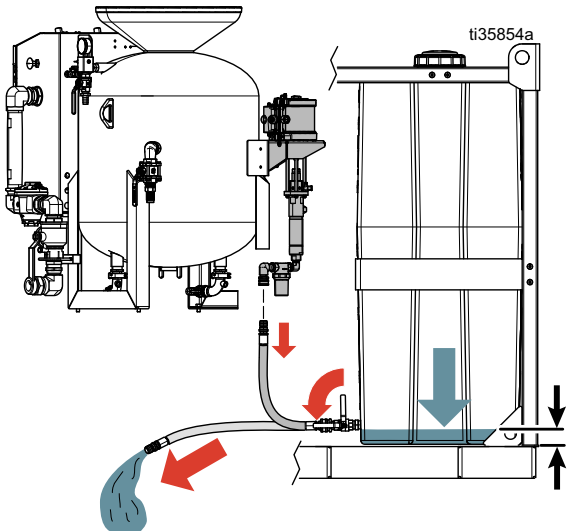
**NOTICE**

If ice forms behind the seals, the seals can become damaged. During storage, position all ball valves in the open position.

**Clean the Water Tank**

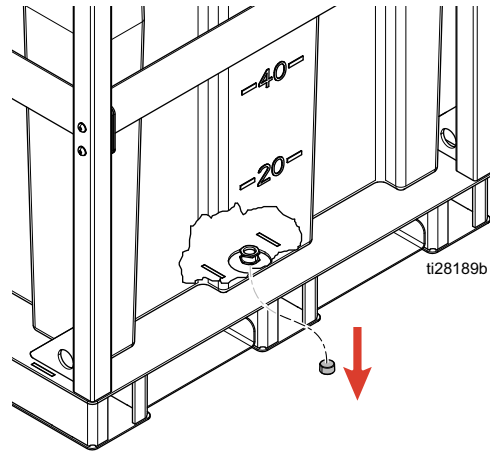


1. Follow the **Pressure Relief Procedure**. See page 17.
2. Disconnect the water inlet hose.



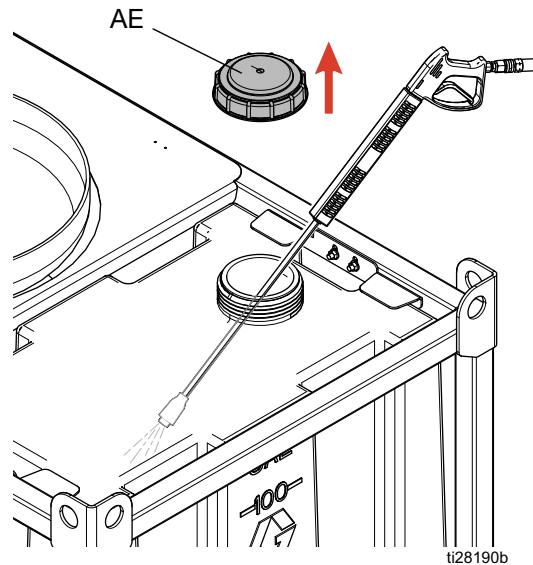
**FIG. 41: Disconnect the Water Inlet Hose**

3. Open the water tank valve (AG) and drain.
4. Remove the tank drain.



**FIG. 42: Remove the Tank Drain**

5. Remove the tank lid (AE).



**FIG. 43: Remove the Tank Lid**

6. Clean out the tank with a pressure washer.

# Troubleshooting



Problem	Cause	Solution
Unable to fill or pressurize the pot with water.	The emergency stop (M) is engaged.	Disengage the emergency stop (M).
	The air supply is inadequate.	Make sure the air compressor is capable of supplying the minimum air flow requirements for your system. See , page 61. Make sure the air inlet pressure gauge reads 100-150 psi (6.8-10 bar, 0.68-1.0 MPa). If the gauge does not read 100-155 psi, check the air compressor for proper setup. Make sure the air inlet filters are clean, and replace if necessary.
	Inadequate water supply to the pump.	<p><b>Systems with water tanks:</b> Make sure the water tank is full and the inlet ball valve is open. Clean or replace water inlet filter if necessary. Make sure all fittings connections are tight.</p> <p><b>Systems without water tanks:</b></p> <ul style="list-style-type: none"> <li>• Ensure water supply connection is connected and pressurized.</li> <li>• Check that water supply meets appropriate pressure and flow requirements. See <b>Connect the Water Supply</b>, page 13, step 1.</li> <li>• Ensure all fitting connections are tight.</li> <li>• Check water pressure regulator (G) for proper flow direction installation.</li> <li>• Check inlet water pressure regulator screen filter for debris, clean if possible.</li> <li>• Replace regulator if no flow can be passed through regulator.</li> </ul>
	The water pump air regulator is malfunctioning.	Disengage the blast control switch (AK). Adjust the pump air pressure regulator until the pump air pressure regulator gauge reads 60 psi (4.1 bar, 0.41 MPa). If you are unable to attain this setting, check the air inlet filters and make sure the supply air pressure is greater than or equal to 60 psi. If the above steps do not resolve issue, replace the pump air pressure regulator.
	The water pump is malfunctioning.	Rotate 3-way selector valve to OFF position. Open rinse valve and ensure pump cycles, and water flows from rinse hose. Close rinse valve and verify that pump stalls. If pump continues to creep or will not prime, refer to your pump manual for pump service.
	The pop-up cannot seal.	Make sure the pot seal plunger is clean and free of debris in the o-ring sealing area. Check for proper pot seal plunger alignment in the closed position. There should be no gaps between the o-ring and the pot seal plunger. Remove the o-ring and make sure the o-ring gland is clear of debris. Replace the o-ring and/or pot seal plunger if worn.
	The water pressure regulator is malfunctioning.	Adjust the water pressure regulator until the pot pressure gauge (C) reads 185 psi (12.75 bar, 1.275 MPa). If this adjustment is not possible, service the water pressure regulator. Refer to your fluid regulator manual.

Problem	Cause	Solution
The blast hose recoils heavily when the blast control switch (AK) is engaged. Large slugs of abrasive and water are ejected from nozzle.	The abrasive ball valve was left open during shut down.	Blast on a test material until the system returns to normal operation.
	The abrasive ball valve is worn.	With the pot pressurized and the abrasive ball valve closed, engage the blast control switch (AK) and check to make sure the pump is stalled. If the pump rod is creeping, replace the abrasive ball valve (Z1 or Z2), or replace abrasive ball valve seals. See <b>Common Spare Parts</b> , page 57.
	The pinch hose is worn.	With the pot pressurized and the abrasive ball valve open, check to make sure the pump is stalled. If the pump rod is creeping, replace the pinch hose. See <b>Replace the Pinch Hose</b> , page 36.
The pot pressure relief valve is discharging water.	The water pressure regulator is malfunctioning.	Adjust the water pressure regulator to 185 psi (12.75 bar, 1.275 MPa). If this adjustment is not possible, service the water pressure regulator, refer to your fluid regulator manual.
	The pressure relief valve has failed.	Replace the pressure relief valve (D) if weeping occurs at or below 185 psi (12.75 bar, 1.275 MPa).
No blast air flow when the blast control switch (AK) is engaged. The water pump does cycle while the blast control switch is engaged.	The adjustable blast regulator (K) is not adjusted to the correct pressure.	Adjust the blast air regulator (K) to the desired pressure while the blast control is engaged.
	The tubing to the main air regulator is not properly connected or there are air leaks in the fittings or tubing.	Check for leaks at the tubing connection points.
	The main blast air regulator is malfunctioning.	Clean or replace the main blast air regulator (AP).
	The main air regulator is malfunctioning.	Disassemble the main air regulator and inspect components. Replace or repair parts as necessary. See <b>Enclosure</b> , page 46.

Problem	Cause	Solution
<p>No blast air flow when the blast control switch (AK) is engaged. The water pump does not cycle while the blast control switch is engaged.</p>	<p>The emergency stop (M) is engaged.</p>	<p>Disengage the emergency stop (M).</p>
	<p>The air supply is inadequate.</p>	<p>Make sure the air compressor is capable of supplying the minimum air flow requirements for your system. See , page 61, for more information. Make sure the supply pressure gauge (S) reads 100-150 psi (6.8-10 bar, 0.68-1.0 MPa). If the gauge does not read 100-150 psi, check the air compressor for proper setup.</p>
	<p>The electric blast control circuit is malfunctioning.</p>	<p>Ensure proper 12V DC supply is connected, and at full charge. Inspect cable for damaged or 'open' wiring. Check the 400 mA fuses and replace if necessary. Check for continuity through connectors on the control box and all external cables. Check continuity through the electric blast control switch (AK) (the switch is normally open). If all above items are functional, replace the 4-way solenoid valve.</p>
	<p>The pneumatic blast control circuit is malfunctioning.</p>	<p>Actuate the blast control switch (AK) and check for proper spool valve actuation in the 4-way valve. If no actuation occurs, check the blast control switch by disconnecting the yellow tube at the enclosure male quick-disconnect and engage the control switch. If no air comes from the fitting, check the pneumatic blast control filter. If the filter is clean, check for signal air at the blast control switch (AK). Replace the pneumatic blast control switch if signal air does not pass through the valve when the handle is depressed. If the switch is functioning, make sure the yellow tubing inside the control box is properly connected and is clear of obstructions. If the tubing is clean, replace the 4-way solenoid valve.</p>

Problem	Cause	Solution
<p>While in BLAST mode, with the blast control switch (AK) engaged, air is flowing from the nozzle but little or no abrasive is flowing from the nozzle.</p>	<p>The abrasive ball valve is closed.</p>	<p>Open the abrasive ball valve (Z1 or Z2).</p>
	<p>The abrasive metering valve is not properly set.</p>	<p>Adjust the abrasive metering valve (T1, T2) to increase the flow of abrasive,</p>
	<p>The pot does not have a sufficient amount of abrasive.</p>	<p>Refill the pot with media. See <b>Fill Pot with Abrasive Media</b>, page 15.</p>
	<p>The pinch valve does not open.</p>	<p>Engage the blast control switch (AK) and check for actuation of the pinch valve. If there is no actuation, disconnect the orange tubing at the pinch valve. If the pinch valve opens and source air is coming from the orange tubing, confirm that the tubing is correctly routed. If the pinch valve does not open, replace it. If the pinch valve opens and there is no source air coming from the tubing, inspect the mufflers on the 4-way valve for debris. If debris is not present, clean or replace the 4-way valve.</p>
	<p>There is an obstruction inside the pot or inside the abrasive hose between the pot and the enclosure.</p>	<p>Follow <b>Drain the Pot</b>, page 26, followed by the <b>Pressure Relief Procedure</b>, page 17. With the abrasive hose disconnected, inspect the interior of the pinch hose for obstructions or debris and replace if necessary (see <b>Replace the Pinch Hose</b>, page 36). Remove the tri-clamp from the bottom of the pot. Inspect the bottom of the pot and the abrasive hose for obstructions or debris.</p>
	<p>The pot pressure is too low.</p>	<p>With the blast control disengaged, allow the pot to pressurize and wait for the pump to stall. If the pot pressure gauge does not reach 185 psi (12.75 bar, 1.275 MPa), see the “Unable to fill or pressurize the pot with water” problem listed on this table.</p>
	<p>The blast pressure is too high.</p>	<p>If the blast pressure gauge reads 150 psi (10.3 bar, 1.03 MPa) or greater, it may not be possible to achieve than 15 CPM on the MediaTrak. This is more common with fine mesh abrasive usage. Decrease the blast pressure to 100 psi (6.9 bar, 0.69 MPa) to see if the cpm can be increased.</p>
<p>The blast control switch (AK) is not engaged, but blasting occurs.</p>	<p>The air supply is inadequate.</p>	<p>Make sure the air compressor is capable of supplying the minimum air flow requirements for your system. See , page 61. Makes sure the air inlet pressure gauge reads 100-150 psi (6.8-10 bar, 0.68-1.0 MPa). If the gauge does not read 100-150 psi, check the air compressor for proper setup.</p>
	<p>The main air regulator is malfunctioning or is stuck open.</p>	<p>Disassemble the main air regulator and check for obstructions. Replace or repair parts as necessary. See <b>Enclosure</b>, page 46.</p>
	<p>The electric blast control circuit is malfunctioning.</p>	<p>Unplug the hose cable at the control box. If the blast stops, inspect the hose cable for shortened wiring. Check continuity through the electric blast control switch (AK) (the switch is normally open). Check for continuity across connectors of the recessed plugs on the control box. There should be no continuity. If all above items are functional, replace the 4-way solenoid valve.</p>
	<p>The pneumatic blast control circuit is malfunctioning.</p>	<p>Engage the emergency stop (M). If blasting stops, check the blast control switch (AK) by disconnecting the yellow tube at the enclosure male quick-disconnect. There should be no signal air unless you engage the control switch. If the switch is functioning, remove the exhaust mufflers from the 4-way and check for debris, clean ports, and replace the mufflers if necessary. If all above items are functional, replace the 4-way solenoid valve.</p>



Problem	Cause	Solution
<p>While the blast control switch (AK) is engaged, the blast air flow is fluctuating.</p>	<p>The supply air pressure is fluctuating.</p>	<p>Make sure the compressor meets minimum flow requirements and is operating properly. See <b>Technical Specifications</b>, page 62, for more information on flow requirements.</p>
	<p>The main air regulator is malfunctioning or is stuck open.</p>	<p>Disassemble the main air regulator and check for obstructions. Replace or repair parts as necessary. See <b>Enclosure</b>, page 46.</p>
	<p>The electric blast control circuit is malfunctioning.</p>	<p>Inspect the hose cable for damaged or shorted partially open wiring. Check the 3A fuse and replace if necessary. Check for loose wire connections on the recessed plugs on the control box (AC) and all external cables. Check continuity through the electric blast control switch (AK) (the switch is normally open). If all above items are functional, replace the 4-way solenoid valve.</p>
	<p>The pneumatic blast control circuit is malfunctioning.</p>	<p>Actuate the blast control switch (AK) and check for proper spool valve actuation in the 4-way valve. If no actuation occurs, check the blast control switch by disconnecting the yellow tube at the enclosure male quick disconnect and engage the control switch. If only a little air comes from the fitting, check the twin-line hose for damage or crimping and check the pneumatic blast control filter. If the twin-line and filter are clean, replace the pneumatic blast control switch. If the switch is functioning, make sure the yellow tubing inside the control box is properly connected and clear any obstructions. If all above items are functional, replace the 4-way solenoid valve.</p>
<p>The blast spray pattern is sputtering or irregular.</p>	<p>The air supply is inadequate.</p>	<p>Make sure the air compressor is capable of supplying the minimum air flow requirement for your system. See , page 61. Make sure the air inlet pressure gauge reads 100-150 psi (6.8-10 bar, 0.68-1.0 MPa). If the gauge does not read 100-150 psi, check the air compressor for proper setup. Make sure the air inlet filters are clean and replace if necessary.</p>
	<p>The blast hose was not properly cleaned out after previous use.</p>	<p>Blast on a test material until the system returns to normal operation.</p>
	<p>The abrasive metering valve setting is too high for the blast pressure and/or abrasive type.</p>	<p>See <b>Setting the Abrasive Metering Valve</b>, page 20.</p>
	<p>The pot does not have a sufficient amount of abrasive.</p>	<p>Refill the pot with abrasive. See <b>Refill Pot with Media</b>, page 20.</p>
	<p>There is an obstruction in the nozzle.</p>	<p>Remove the nozzle and inspect for blockage, buildup, or damage. Replace the nozzle if necessary.</p>
	<p>There is an obstruction inside the pot or inside the abrasive hose between the pot and the enclosure.</p>	<p><b>Drain the Pot</b>, page 26, then perform the <b>Pressure Relief Procedure</b>, page 17. With the abrasive hose disconnected, inspect the interior of the pinch hose for obstructions or debris and replace if necessary. See <b>Replace the Pinch Hose</b>, page 36. Remove the tri-clamp from the bottom of pot. Inspect the bottom of the pot and abrasive hose for obstructions or debris.</p>

Problem	Cause	Solution
Too much dust occurs during blasting.	There is not enough water in abrasive mixture.	See <b>Use the Water Dose Meters</b> , page 20.
	The blast pressure is too high.	Decrease the blast pressure and re-evaluate the dust levels.
	The abrasive is too fine for the application.	Try a coarser or harder abrasive if possible.
Too much water is coming from the nozzle in BLAST mode.	The water dose valve (L1 or L2) is open too far.	Close the water dose valve (L1 or L2).
	The abrasive material is too coarse.	If possible, use at least 20 mesh abrasive material. Otherwise, decrease the CPM setpoint until the pattern improves.
	The abrasive metering valve setting is too high for blast pressure and/or abrasive type.	See <b>Setting the Abrasive Metering Valve</b> , page 20.

# Repair

## Replace the DataTrak Battery

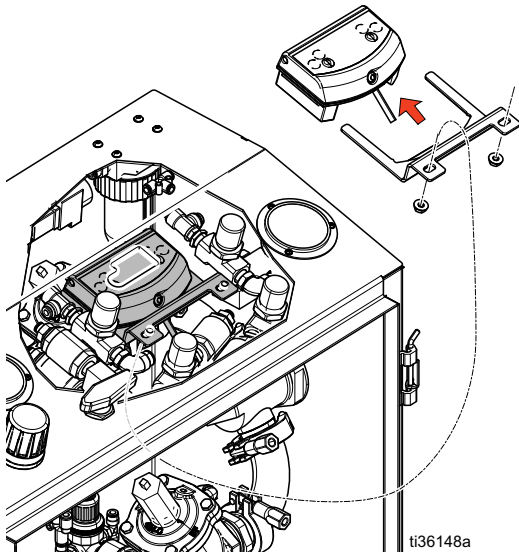


**FIRE AND EXPLOSION HAZARD**

To reduce the risk of fire and explosion, the battery must be replaced in a non-hazardous location.

Use only an approved replacement battery. Use of an unapproved battery will void Graco's warranty.

1. Unscrew the DataTrak cable from the extension cable inside the enclosure.
2. Remove the DataTrak module from the bracket.



ti36148a

**FIG. 44: Remove the DataTrak Module**

3. Take the module and attached cable to a non-hazardous location.
4. Remove the two screws on the back of the module to access the battery.
5. Disconnect the used battery and replace it with an approved battery.

Approved Batteries
Energizer® brand alkaline #522
Varta® brand alkaline #4922
UltraLife® brand lithium #U9VL
Duracell® brand alkaline #MN1604

## Replace the Pinch Hose

### Remove the Pinch Hose



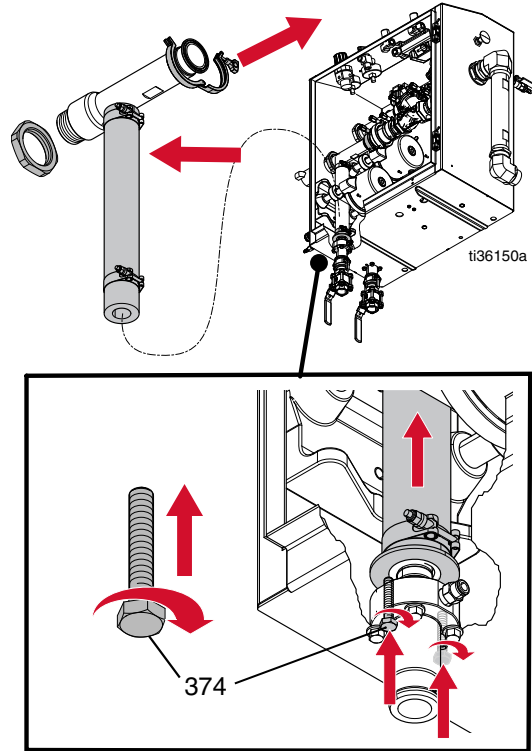
1. Perform the **Pressure Relief Procedure**, page 17.
2. Remove the claw coupler (314) at the swivel connection.
3. Use the supplied 2-7/8 in. wrenches to loosen the lock nuts (29) on the inside and outside of the box.
4. Remove the clamp (71) connecting the blast circuit (59) to the check valve.
5. Remove the check valve assembly (95) and clean all abrasive that may be stuck to the check valve components.

#### NOTICE

Check valve components coated in abrasive can allow abrasive to enter the main air regulator and lead to improper operation. Clean off all abrasive material that may be stuck to the check valve components to allow for proper operation.

6. Remove the bottom hose clamp (73).
7. Install 1/4-20 in. jacking screws (374) into the camlock manifold.

8. Turn the jacking screws (374) one at a time. The jacking screws will push up the push washer, which will push the pinch hose up and off of the barbs.



**FIG. 45**

9. Pull the pinch hose (46, 76) out of the box.

**NOTE:** Use the blast circuit (59) as a handle, and twist while pulling.

10. Loosen the remaining hose clamp and remove the pinch hose from the circuit.



### Install the Pinch Hose

1. Reinstall the check valve (95), ensuring proper orientation. Assemble the valve with the plunger facing the AQ Matic valve (96).
2. Place both hose clamps on the pinch hose. Leave 1/4 in. of the hose exposed on both ends.
3. Remove the 1/4-20 in. jacking screws (374) from the camlock manifold.
4. Reinstall the push washer (99) over the barbs.
5. Slide the pinch hose into the box through the pinch valve.
6. Reinstall the blast circuit (59) and pinch hose into the box through the pinch valve.
7. Install and tighten the clamp to 15 ft-lb (20.3 N•m) to connect the blast circuit to the check valve.

**NOTE:** If necessary, loosen the inside nut to provide room to install the gasket. Inspect the gasket and replace as necessary.

8. Apply anti-seize to the threads on the clamps (71).
9. Align the nuts pointing towards the front of the enclosure. Torque the nuts to 85 +/-5 in-lb (9.6 +/- 0.5 N•m).
10. Tighten the lock nuts (29).
11. Install the claw coupler (314).

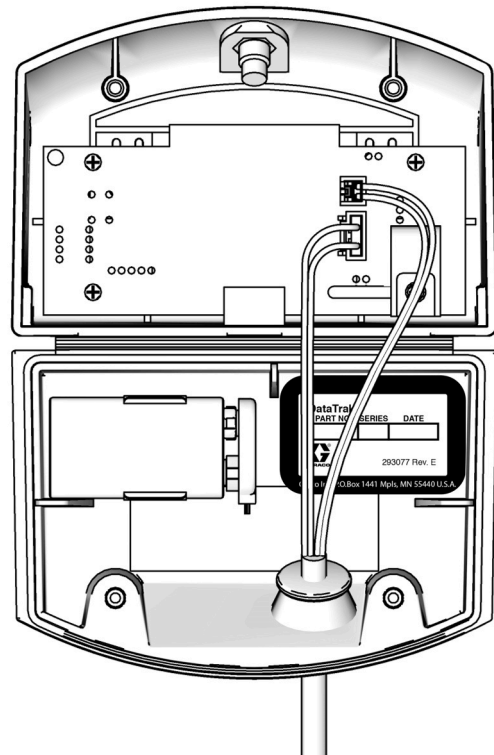
### Replace the DataTrak Fuse

				
<b>FIRE AND EXPLOSION HAZARD</b>				
To reduce the risk of fire and explosion, the battery must be replaced in a non-hazardous location.				
Use only an approved replacement battery. Use of an unapproved battery will void Graco's warranty.				

1. Remove the screw, metal strap, and plastic holder. Set aside.
2. Pull the fuse away from the DataTrak board.
3. Install an approved fuse.

Approved Fuses	
DataTrak Part	Fuse
17K057	24V216
All other part numbers	

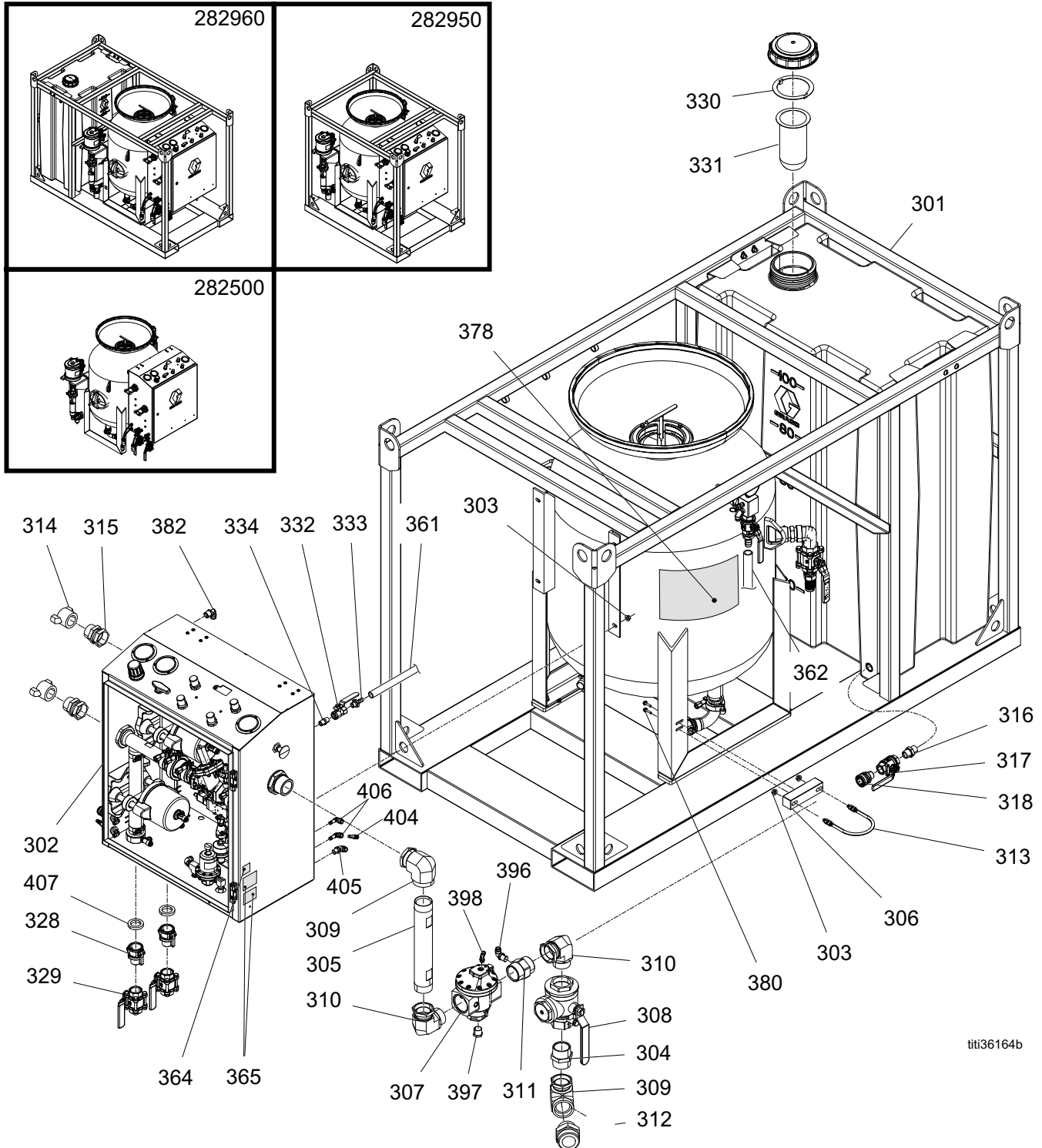
4. Replace the plastic holder, metal strap, and screw.

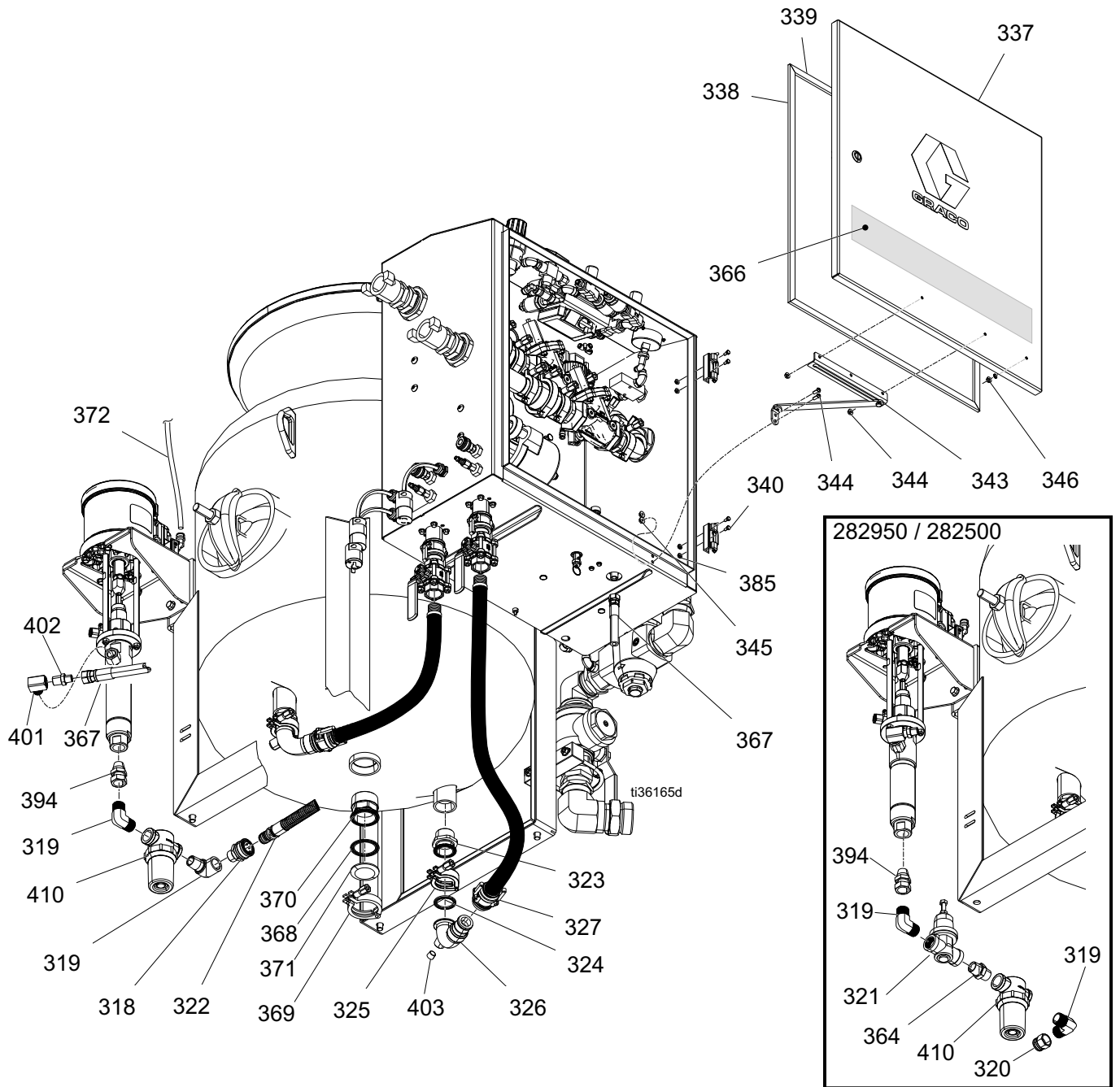


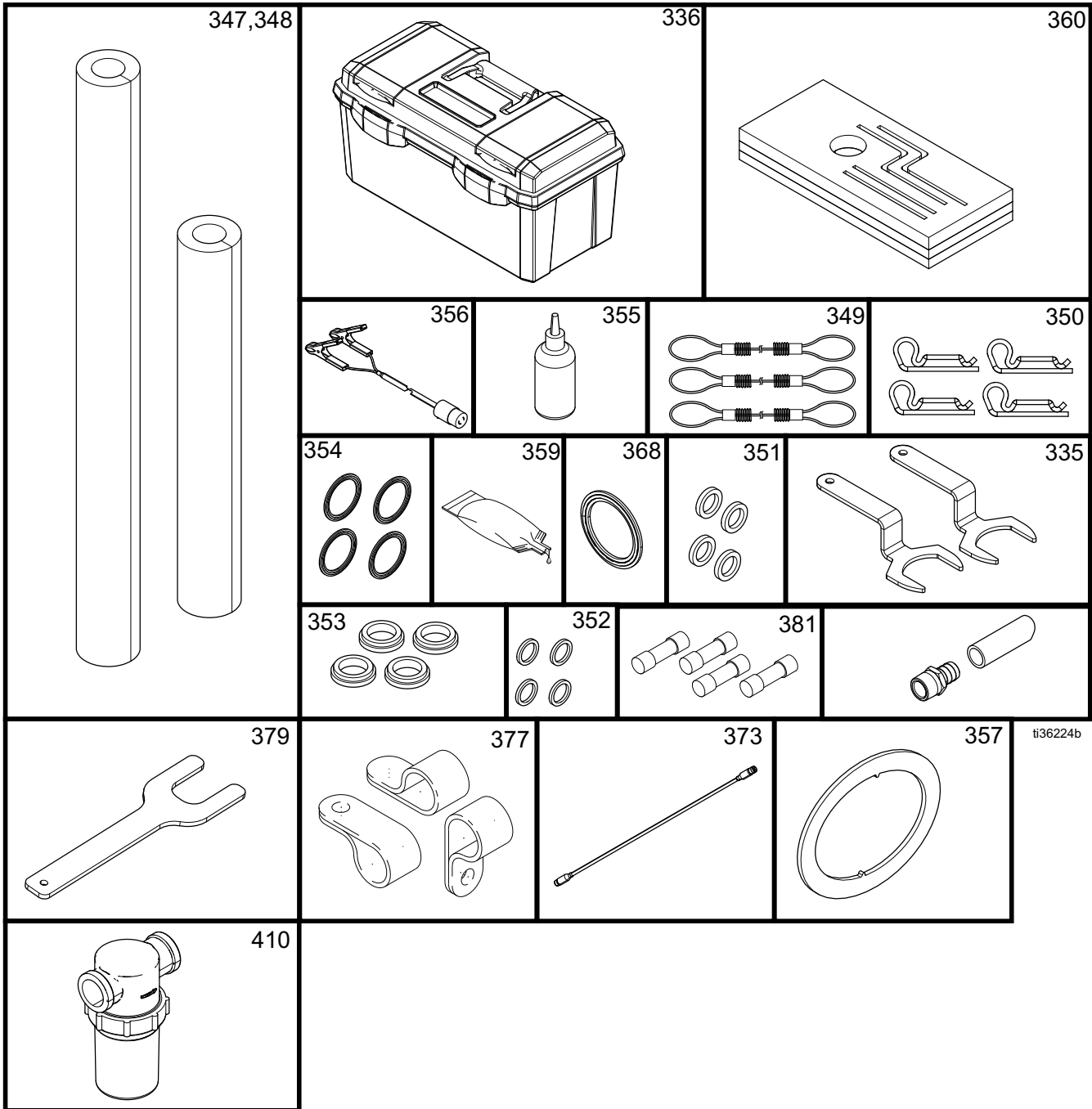
**FIG. 46: Inside the DataTrak**

# Parts

## EcoQuip 2 System









## System Parts List

Ref.	Part	Description	Qty.		
			282960	282950	282500
			EQs DL with tank	EQs DL	EQc DL
301	-----	BASE, Dual Line, frame, no tank (see page 44)	-----	1	-----
	-----	BASE, Dual Line, no frame (see page 44)	-----	-----	1
	-----	BASE, Dual Line, frame, tank (see page 44)	1	-----	-----
302	-----	ENCLOSURE, EcoQuip, Dual Line (see page 46)	1	1	1
303	128226	NUT, flange, 3/8-16, sst	4	4	4
304☼	121435	FITTING, nipple, hex, 2	1	1	1
305	18A339	FITTING, nipple, 2 x 14 in	1	1	1
306†	-----	SPACER, block	1	1	1
307‡	-----	REGULATOR, air, 2 in., piloted, relieving	1	1	1
308☼	-----	VALVE, ball, 2 in., brass, with filter	1	1	1
309	19A729PKG	FITTING, elbow, swivel, female, cs, 2	2	2	2
310‡☼	-----	FITTING, elbow, swivel, male, cs, 2	2	2	2
311‡	18A338	FITTING, nipple, 2 in., side port	1	1	1
312	19A823	FITTING, ground joint spud, 2 in. npt	1	1	1
313†	-----	BOLT, u, 4-1/8 in., 3/8-16	1	1	1
314	EQ1934	COUPLER, sandblast, 1-1/2 npt(f), br	2	2	2
315	113864	UNION, swivel, 1 1/2 npt	2	2	2
316	190724	NIPPLE, sst.	1	-----	-----
317	129903	VALVE, ball, 2pc, sst, 3/4 in. npt	1	-----	-----
318	EQ1846	COUPLER, 3/4qd(f), 3/4npt(m), br	2	-----	-----
319	17K344	FITTING, elbow, 3/4 npt, sst	1	2	2
320	EQ7004	FITTING, hose, garden, 3/4 in. mpt x	-----	1	1
320	115813	FITTING, street elbow, 3/4 npt	1	-----	-----
321	18B105	REGULATOR, pressure, valve	-----	1	1
322	17J795	HOSE, inlet, water	1	-----	-----
323	17H273	ADAPTER, triclamp, 1-1/4 npt, sst	2	2	2
324	680454	GASKET, sanitary fitting	7	7	7
325	128791	CLAMP, triclamp, 1.5, hex nut	2	2	2
326	17L631	MANIFOLD, unequal-tee	2	2	2
327	17L329	HOSE, inlet media (includes Ref. 407)	2	2	2
328	17J329	COUPLER, cam-lock, sst, 1 nptf	2	2	2
329!	17L046	VALVE, ball, 1 in., 3pc, wog, sst	2	2	2
330+	-----	RING, adapter, filter	1	-----	-----
331+	-----	FILTER, element, water tank	1	-----	-----
332	EQ1002	VALVE, ball, 3/8 npt, sst	1	1	1
333	EQ1627	FITTING, nipple, barb. hose. 3/8	1	1	1
334	167702	NIPPLE, pipe	1	1	1
335	17L633	TOOL, eq, wrench, 2-7/8	1	1	1

## Parts

Ref.	Part	Description	Qty.		
			282960	282950	282500
			EQs DL with tank	EQs DL	EQc DL
336★	-----	BOX, tool, 20 in., black	1	1	1
337❖	-----	DOOR, enclosure, large, painted	1	1	1
338◆	-----	GASKET, door, vertical	2	2	2
339◆	-----	GASKET, door, horizontal	2	2	2
340	111639	SCREW, cap, hex hd	4	4	4
341*	17L623	LOCK, door, tooled (includes Ref. 342)	1	1	1
342*	-----	LATCH, cam, door lock	1	1	1
343~	-----	DOOR, stay	1	1	1
344~	128666	SCREW, cap, button hd, m6x16, sst	2	2	2
345~	15U698	NUT, hex, flange, serrated	2	2	2
346~	127908	NUT, flange, serrated, #10-32, ss	2	2	2
347	19A746PKG	HOSE, pinch, long	1	1	1
348	17K051	HOSE, pinch	1	1	1
349	17D786	CABLE, safety item, hose, whip-check	3	3	3
350	17D787	PIN, safety item, hose, hair c	4	4	4
351	17L309	GASKET, cam lock, buna, 1.00	4	4	4
352	EQ1051	GASKET, blast nozzle	4	4	4
353	17C124	GASKET, metal blast coupler	4	4	4
354	502598	GASKET, sanitary (ptfe)	8	4	4
355	206994	FLUID, TSL 8 oz bottle	1	1	1
356	EQ5183	CABLE, battery	1	1	1
359	110110	SEALANT, pipe, sst	1	1	1
360★	-----	INSERT, foam, tool box, EcoQuip	1	1	1
361	EQ1840	HOSE, braided, clear, 3/8 id	6	6	6
362	EQ1360	HOSE, braided, clear, 3/4 id	3	3	3
363*	-----	HOSE, tubing, 3/8 od, natural	1	1	1
364	190724	NIPPLE, sst	1	1	1
367	25B197PKG	HOSE, clpd, 3/8	1	1	1
368✘	-----	GASKET, tri-clamp, 2	1	1	1
369✘	-----	CLAMP, tri-clamp, hex nut, sst, 2	1	1	1
370	19A834	ADAPTER, tri-clamp, 2 in. npt male, sst	1	1	1
371✘	-----	CAP, tri-clamp, sst, 2	1	1	1
372*	061513	TUBE, nylon, 1/2 od x 3/8 id	1	1	1
373	17Y983	CABLE, GCA, m12-5p, m/f, 2.0m	1	1	1
374	100058	SCREW, cap, hex hd	4	4	4
377	411111	CLAMP, metal	3	3	-----
378	3A6838	QUICK GUIDE, EcoQuip Dual Line	1	1	1
379	19A756	TOOL, pry, hose	1	1	1
380†	15R472	FASTENER, hex hd, flanged, 1/4 x 1	2	2	2

Ref.	Part	Description	Qty.		
			282960	282950	282500
			EQs DL with tank	EQs DL	EQc DL
381	18A604	FUSE, glass, 0.25 x 1.25, 400 ma	4	4	4
382	127846	FITTING, elbow, push-to-connect, 1/2	1	1	1
385	127918	NUT, flange, serrated, m5	4	4	4
396	EQ1798	FITTING, ptc, elbow, 1/2 mpt, 3/8 OD	1	1	1
397	16K281	VENT, breather, muffler	1	1	1
398	121022	FITTING, elbow, male, 1/4 npt	1	1	1
401	132158	FITTING, nickel-plated, pipe, elbow	1	1	1
402	123724	FITTING, nipple, hex, 1/2 npt x 3/8 npt	1	1	1
403	112306	PLUG, pipe, 3/8 npt, sst	1	1	1
404	EQ1759	FITTING, stem, reducer, 1/4 in. x 3/8 in.	1	1	1
405	EQ1500	FITTING, elbow, swivel, male, 3/8 in.	1	1	1
406	EQ1122	FITTING, elbow, stem, 3/8 in.	1	1	1
407	17L309	GASKET, camlock, buna, 1.0	2	2	2
410	17L332	STRAINER, in line, 80x80 mesh, 3/4 npt	1	1	1

\* Not shown.

† Part included in Spacer Block Kit 25P177 (purchase separately).

‡ Part included in Piloted Air Regulator Kit 25P176 (purchase separately).

❖ Part included in Enclosure Door Kit 25P171 (purchase separately).

◆ Part included in Door Gasket Kit 25P178 (purchase separately).

✘ Part included in Quick Drain Fitting Kit 25P189 (purchase separately).

⊛ Part included in 2 in. Ball Valve Kit 25P234 (purchase separately).

⊕ Part included in Filter and Adapter Kit 26A093 (purchase separately).

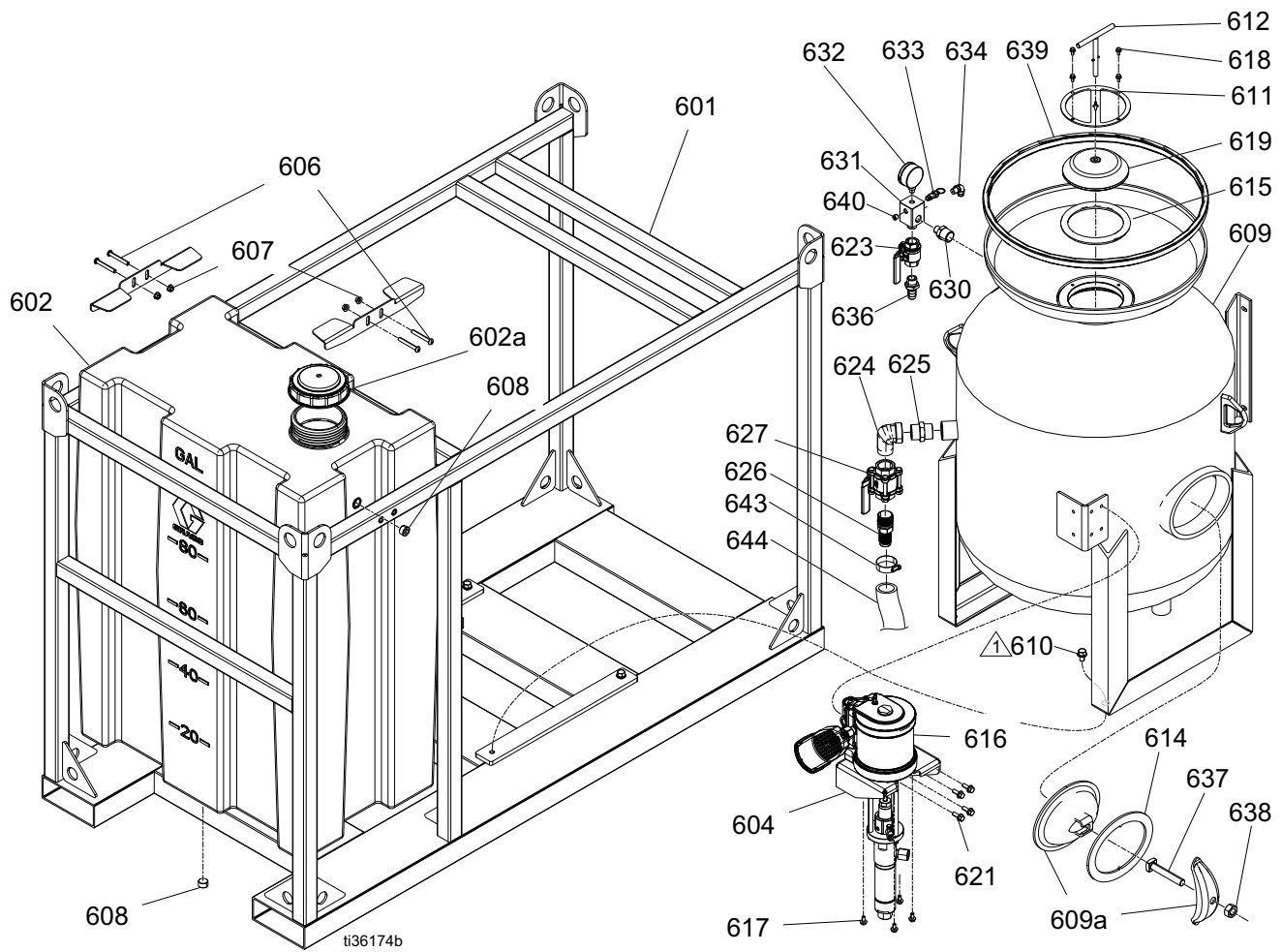
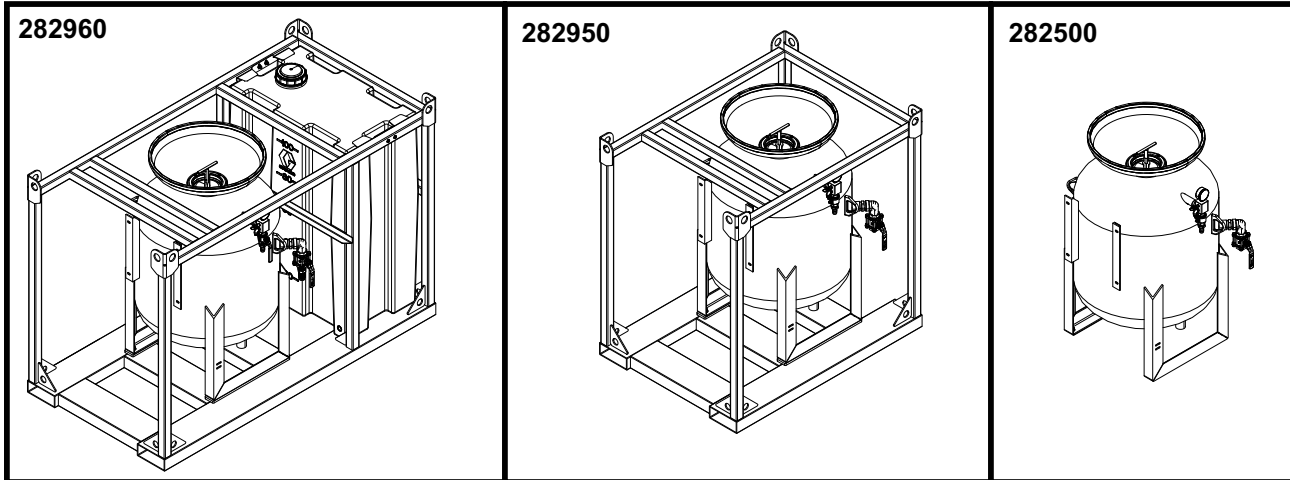
★ Part included in Tool Box Kit 24Z156 (purchase separately).

~ Part included in Door Stay Kit 17D686 (purchase separately).

! Seal repair kit available, see **Common Spare Parts** page 57.

# Base (Frame and Pot)

Ref. 301



## Base (Frame and Pot) Parts List

Ref.	Part	Description	Qty.		
			282960	282950	282500
			EQs DL with tank	EQs DL	EQc DL
601	25B212PKG	FRAME, cs, no water tank, paint	-----	1	-----
	19J057PKG	FRAME, cs, Dual Line	1	-----	-----
602	17K048	TANK, EcoQuip 2, polyethylene	1	-----	-----
603	120415	GROMMET, pulley fan GH833	1	1	1
604	18A336PKG	BRACKET, motor, mount, paint, EcoQuip 2	1	1	1
605	17L641	BRACKET, tank, clamp, painted	2	-----	-----
606	128818	BOLT, button hd, 3/8-16 x 2.75	4	-----	-----
607	128226	NUT, flange, 3/8-16, sst	4	-----	-----
608	111384	PLUG, pipe	2	-----	-----
609†	-----	PRESSURE POT, blast media, 12 cu ft	1	1	1
610	128819	BOLT, flange hd, serrated, 1/2, ss	4	4	-----
611†‡	-----	BRACKET, d-ring, pop-up	2	2	2
612†❖	18A383PKG	HANDLE, tee, w/ stop	1	1	1
614‡	17D790	GASKET, handway, 6 in. x 8	1	1	1
615†	17L310	SEAL, o-ring, pressure pot, EcoQuip 2	1	1	1
616	25P031	PUMP, 10:1, EcoQuip	1	1	1
617	111799	SCREW, cap, hex hd	1	4	4
618†‡	128504	BOLT, flange hd, serrated, 1/4, ss	1	4	4
619†❖	18A340PKG	PLUNGER, pot seal	1	1	1
621	132153	BOLT, hex, 3/8-24 x 1	4	4	4
623	129903	VALVE, ball, 2pc, sst, 3/4 in. npt	1	1	1
624	EQ1580	FITTING, elbow, street, 1-1/4 npt, ss	1	1	1
625	EQ1613	FITTING, nipple, hex, 1-1/4 npt, sst	1	1	1
626	19A757	FITTING, barb x npt(m), 1-1/4	1	1	1
627◆	19A747PKG	VALVE, ball, 1-1/4	1	1	1
630	17R930	ADAPTER, nipple, reducing, 1x1/2, sst	1	1	1
631	17J926	MANIFOLD, dump	1	1	1
632	187873	GAUGE, pressure, fluid	1	1	1
633	17L622	VALVE, safety relief, 220 psi	1	1	1
634	EQ1500	FITTING, elbow, swivel, male. 3/8	1	1	1
635	EQ1012	FITTING, nipple, barb, hose. 3/4	1	1	1
637†	129057	BOLT, sq head, 3/4 x 4-1/2, sst	1	-----	-----
638†	17K962	NUT, hex, 3/4-10, sst	1	-----	-----
639	128982	TRIM, edge, neoprene, black, 5/16	1	1	1
640	101970	PLUG, pipe, hdls	1	1	1
641	15V719	FASTENER, screw, slot hex, #8-32 tap	1	1	1
642	24A032	SWITCH, reed assembly	1	1	1
643	101818	CLAMP, hose	1	1	1
644	19A876	HOSE, braided, 1-1/4 in. id, clear	2	2	2

\* Not shown.

† Part included in Pressure Pot Kit 25P166 (purchase separately).

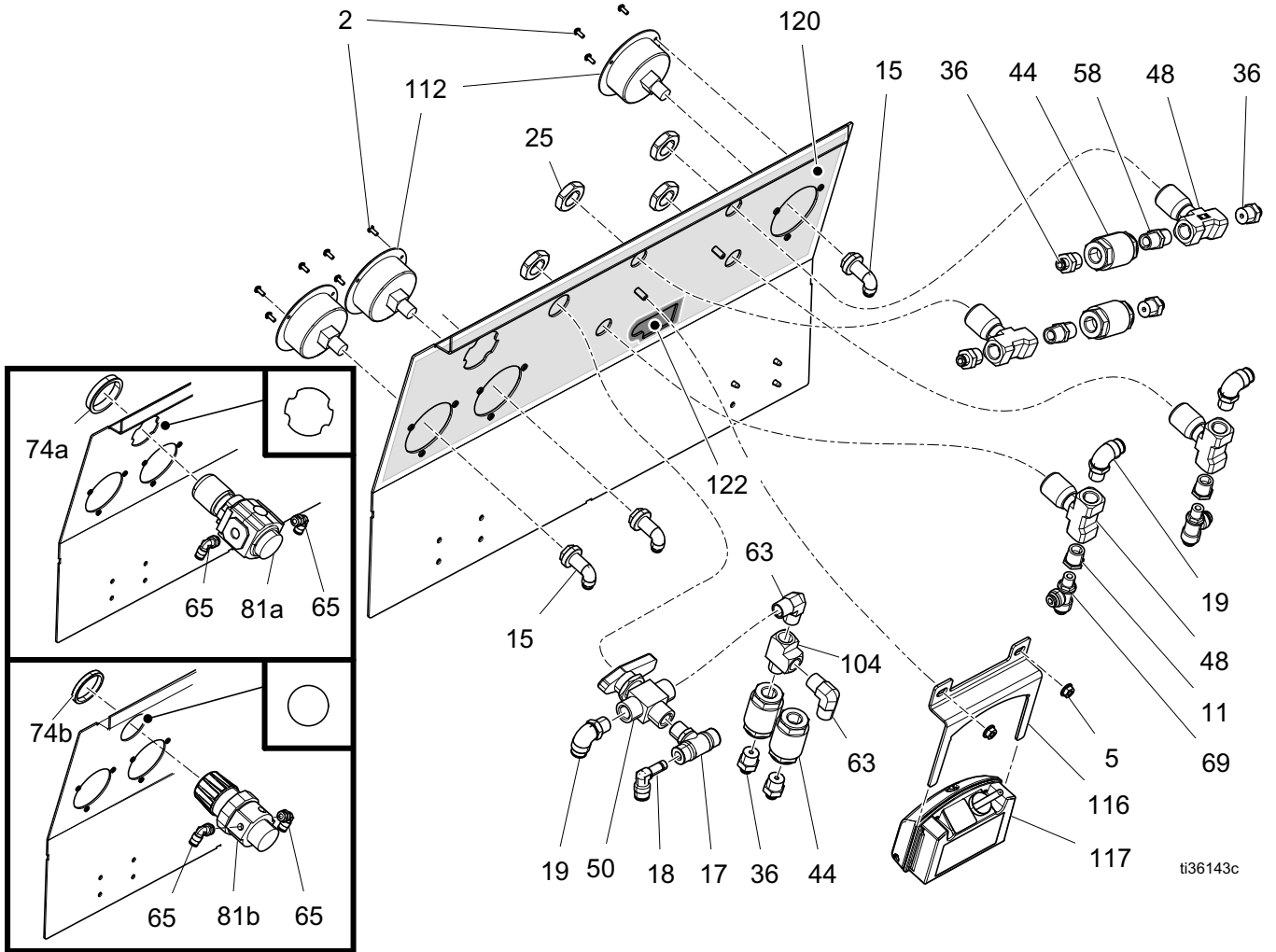
‡ Part included in D-Ring Bracket Kit 25P172 (purchase separately).

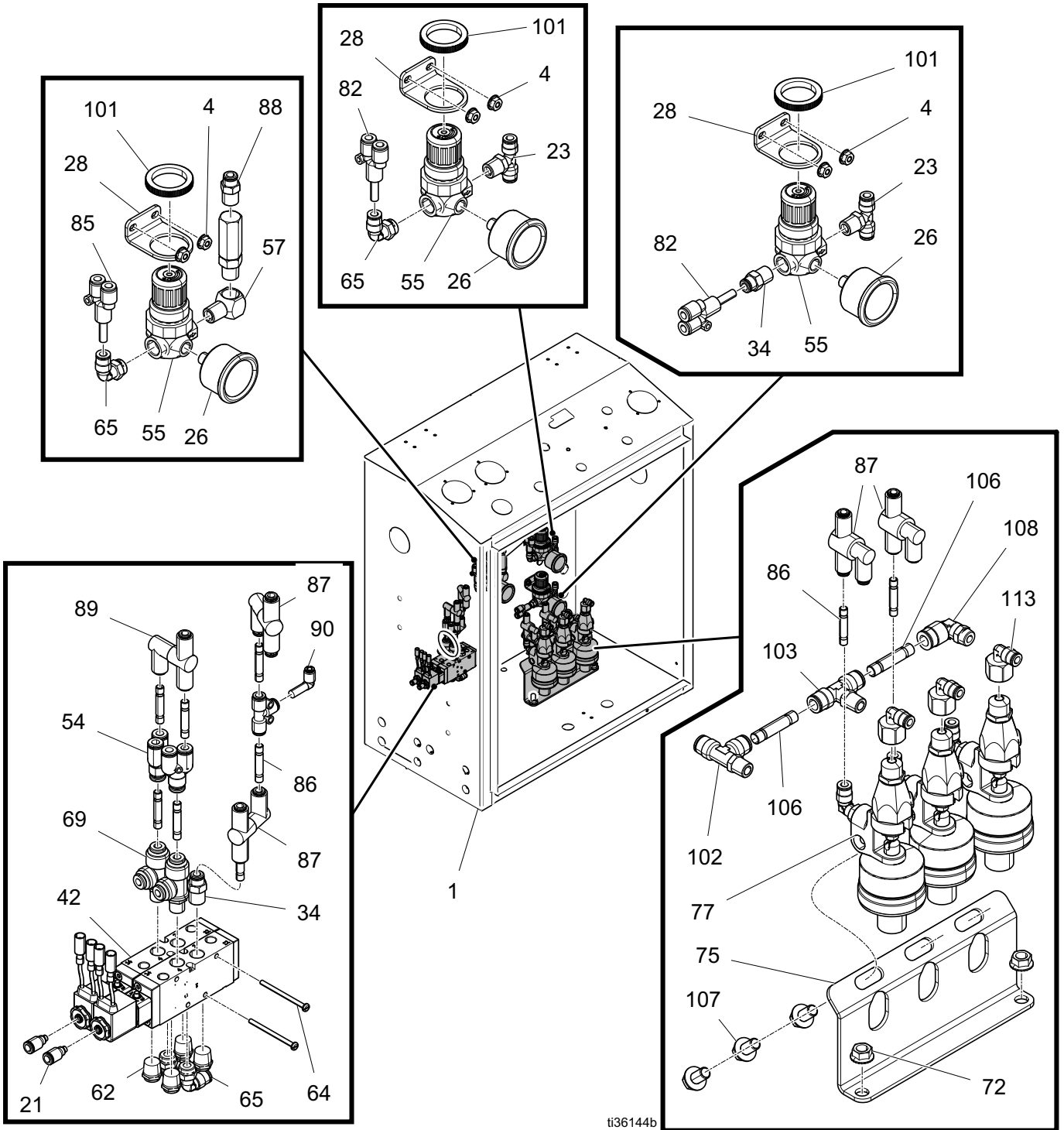
❖ Part included in Pot Seal Plunger Kit 25P252 (purchase separately).

◆ Seal repair kit available, see **Common Spare Parts** page 57.

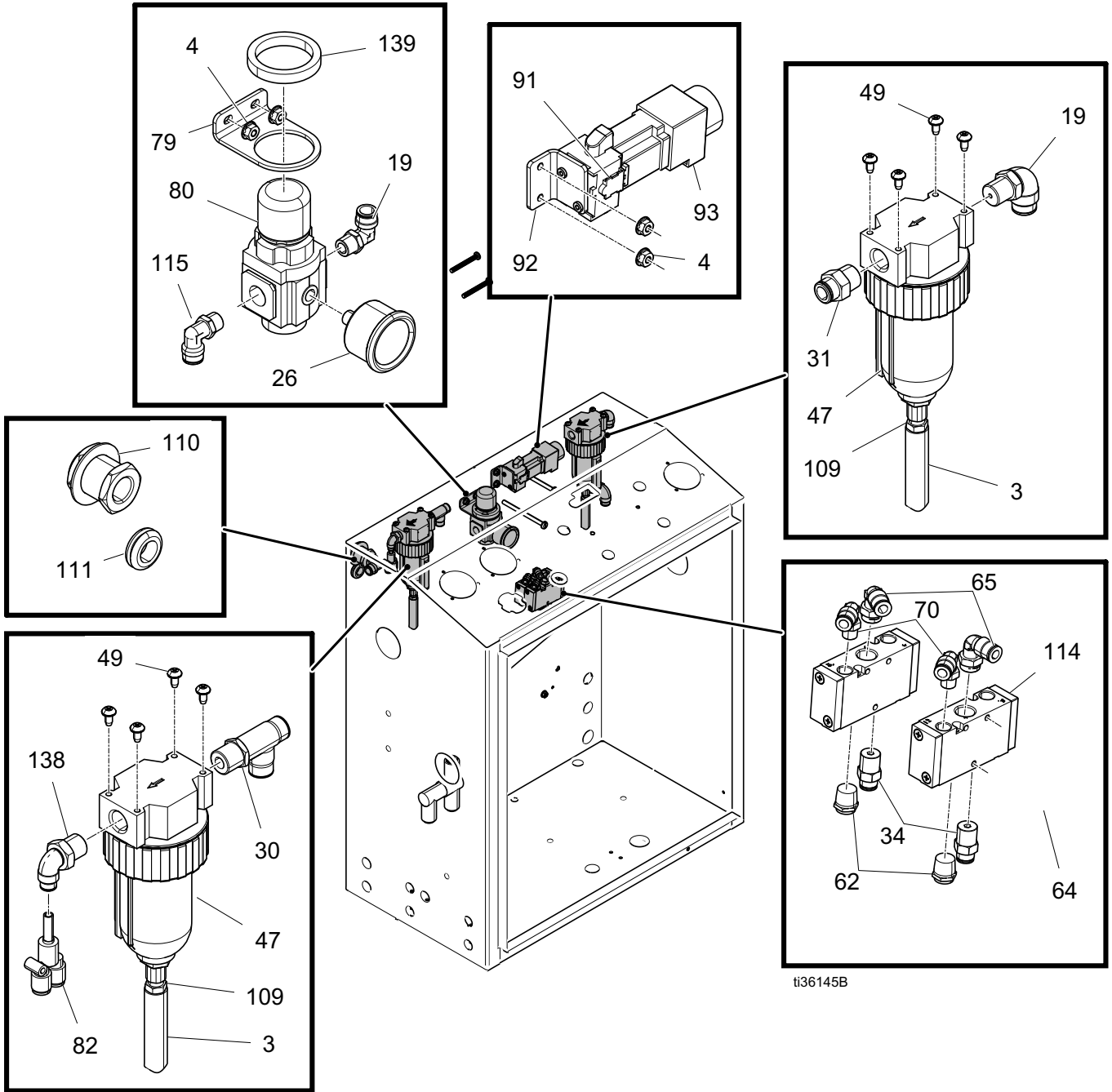
# Enclosure

Ref. 302



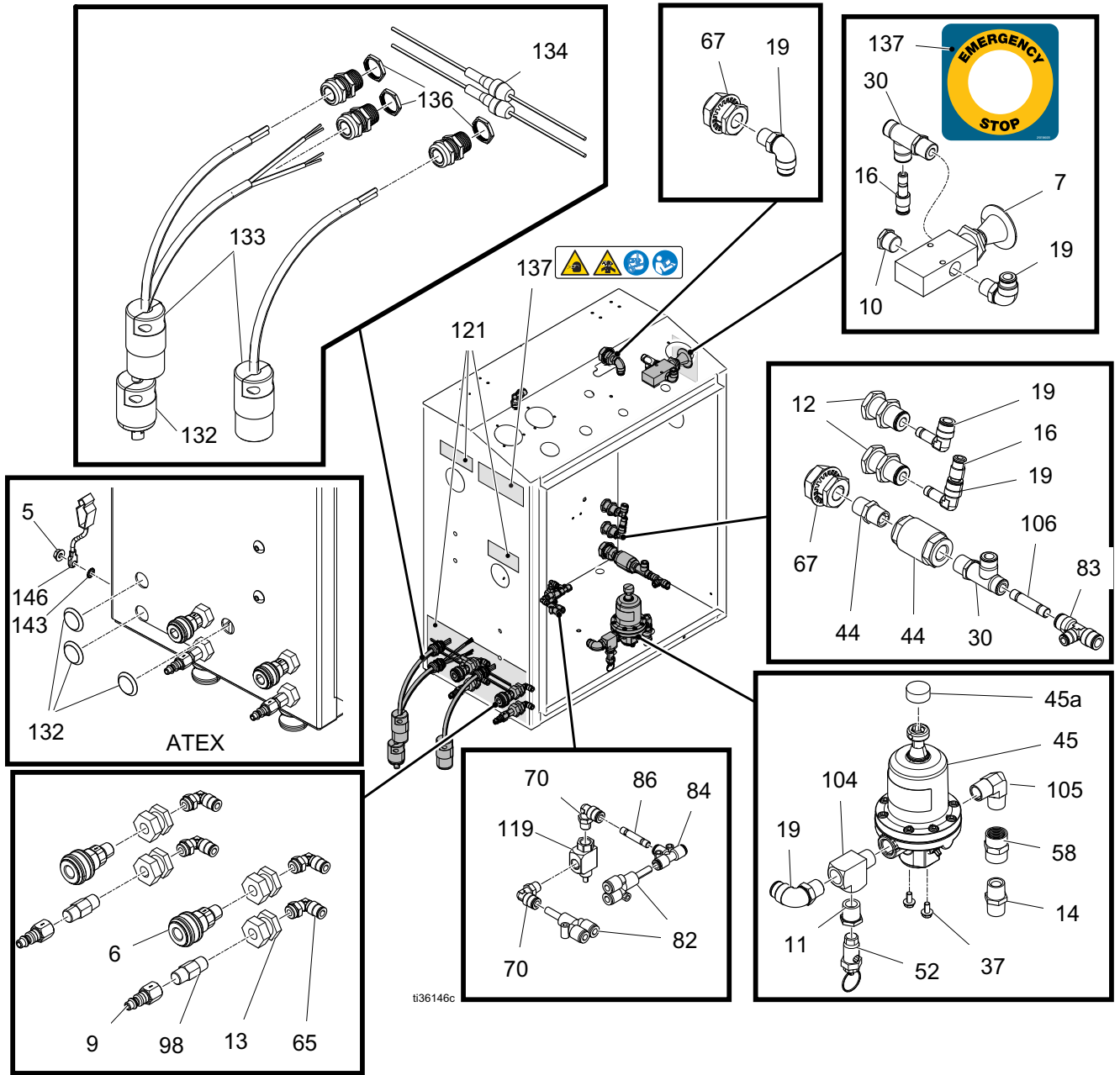


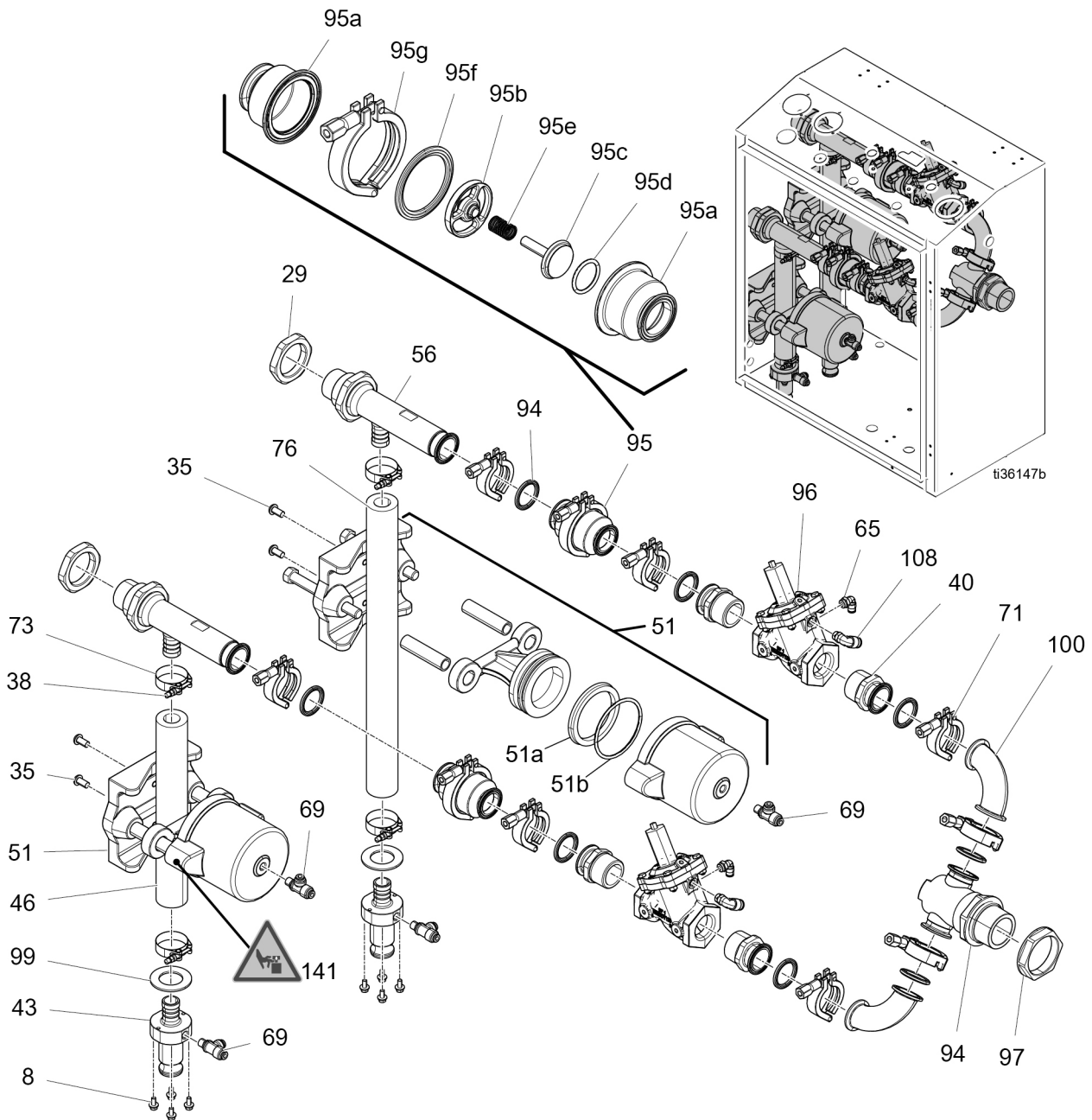
ti36144b



ti36145B







## Enclosure Parts List

Ref.	Part	Description	Qty.
1	25P191	ENCLOSURE, EcoQuip Dual Line	1
2+	127929	SCREW, sems, #6-32, 3/8 in., sst	9
3	EQ1840	HOSE, braided, clear, 3/8 id	2
4	127908	NUT, flange, serrated, #10-32, ss	10
5	127917	NUT, flange, serrated, 1/4-20, ss	2
6	EQ1813	COUPLER, air, 1/4qd(f), 1/4npt(m), br	2
7	EQ5108	VALVE, 3-way. e-stop, 3/8 in. fpt	1
8	128504	BOLT, flange hd, serrated, 1/4, ss	8
9	EQ1421	COUPLER, air, 1/4qd(m), 1/4npt(f), br	2
10	EQ1438	VENT, breather, 3/8 npt	1
11	126109	FITTING, bushing, adapter, 3/8 x 1/4	3
12	EQ1115	BULKHEAD, connector. union 3/8	2
13	123390	FITTING, fitting, 1/4npt, brs	4
15	EQ1113	FITTING, elbow. swivel. female. 1/	3
16	EQ1759	FITTING, stem. reducer. 1/4 in. x 3/8	2
17	EQ1832	FITTING, tee. branch. swivel male.	1
18	EQ1122	FITTING, elbow. stem. 3/8	3
19	EQ1500	FITTING, elbow. swivel. male. 3/8	7
21	128888	FITTING, ptc, 1/4 tube, m5	2
23	128864	FITTING, ptc, tee, branch, 1/4 od/npt	2
24	128918	CAP, vinyl, 3/4-13/16	1
25	17H280	NUT, m20, needle valve	4
26	17L323	GAUGE, pressure, 1.5 in., 160psi	4
28	17G567	BRACKET, regulator, eq2	3
29	17G574	NUT, bulkhead, 2-1/4, sst	4
30	128634	FITTING, ptc, tee, run, 3/8	3
31	128638	FITTING, ptc, straight, 3/8	2
34	128637	FITTING, ptc, straight, 1/4	6
35	128787	BOLT, button hd, 3/8-16 x 3/4, ss	4
36	128798	FITTING, ptc, 1/4 tube, 3/8 mpt	6
37	128670	BOLT, flange hd, serrated, m5, sst	2
38	128718	CAP, vinyl, 1/4-5/16	4
40†	17G576	ADAPTER, triclamp, 1-1/2 npt, sst	4
42	17K053	VALVE, 4-way solenoid, electric/pneumatic, assembly	1
	17K054	VALVE, 4-way, solenoid, ATEX	1
43	19A742	MANIFOLD, barb, cam-lock	2
44	EQ1034	VALVE, check, 3/8 in., sst	5
45	17L324	REGULATOR, pressure, water, 185 psi	1
46	17K051	HOSE, pinch	1
47*	106148	FILTER, air, 3/8 npt	2
48	17K056	VALVE, needle, 3/8 npt, brass	4
49	128502	SCREW, pan, type f, #10-24, 3/8, sst	8
50	17K055	VALVE, selector, 3-way, 3/8 npt, br	1
51	17K052	VALVE, pinch	2
51a‡	-----	SEAL, piston	1
51b‡	-----	O-RING	1
52	17L622	VALVE, safety relief, 220 psi	1

Parts

Ref.	Part	Description	Qty.
54	129574	FITTING, ptc, union y, 1/4t	4
55	17L322	REGULATOR, air, adj, 100psi	3
56	17F436	MANIFOLD, blast circuit, 1.5,bottom	2
57	100840	FITTING, elbow, street	1
58	167702	NIPPLE, pipe	3
60	680454	GASKET, sanitary fitting	8
62	121021	MUFFLER, 1/4 npt	6
63	15Y239	FITTING, elbow, 3/8 x 3/8 male	2
64	117723	SCREW, mach, x rec, panhd	4
65	121022	FITTING, elbow, male, 1/4 npt	14
67	16N177	FITTING, bulkhead, brass, 3/8	2
68	17Y184	CABLE, gca, m12-5p, m/f, 1.0m	1
69	17E553	FITTING, ptc, run tee 1/4 npt, 1/4	8
70	128863	FITTING, ptc, elbow, 1/4 od, 1/8 npt	6
71	128791	CLAMP, triclamp, 1.5, hex nut	8
72	112958	NUT, hex, flanged, 3/8-16	2
73	128642	CLAMP, hose, t-bolt, 1.88-2.19, sst	4
74a•	-----	NUT, regular panel	1
74b❖	-----	NUT, panel, regulator	1
75	19A744	BRACKET, valve, painted	1
76	19A746PKG	HOSE, pinch, long	1
77	25E676PKG	VALVE, disp, auto, ecoquip	3
78	19A739	BRACKET, time delay	1
79◆	19A737	BRACKET, regulator, EQ2	1
80◆	15T539	REGULATOR, air, 3/8 npt	1
81a•	-----	REGULATOR, air	1
81b❖	-----	REGULATOR, air, 1.75 in (44.5), OD only	1
82	114158	FITTING, adapter, y	6
83	19A764	FITTING, tee, ptc, 1/4 x 3/8 x 3/8	1
84	19A763	FITTING, tee, ptc, 1/4	2
85	19A766	FITTING, y, ptc stem, 5/32	1
86	19A771	FITTING, union, double stem, 1/4	10
87	19A769	VALVE, or	4
88	19A765	FILTER, air, in line	1
89	19A768	VALVE, and	2
90	19A770	FITTING, elbow, ptc, 1/4 in. to 5/32	1
91	19A772	FITTING, elbow, 5/32 od, 5/32 od	3
92✘	-----	BASE, 3-port subbase	1
93✘	-----	RELAY, off delay, 0.1 to 30 sec.	1
94✘	19A718PKG	MANIFOLD, sanitary	1
95	-----	VALVE, check, sanitary, 1.5 inch	2
95a	17K049	VALVE, check, housing	1
95b	17L376	VALVE, check, guide	1
95c	17L377	VALVE, check, piston	1
95d	17L378	VALVE, check, o-ring (5-pack)	1
95e	17L375	VALVE, check, spring	1
95f	17L313	GASKET, sanitary, 2-1/2 in.	1
95g	17L318	TRI-CLAMP, 2-1/2 in.	1
96†❖	-----	VALVE, auto, nc, 1-1/2 in., Aq Matic	2

Ref.	Part	Description	Qty.
97	19A720	NUT, jam, air in	2
98	EQ1814	FILTER, in-line, 1/4 npt(m)	2
99	19A741	WASHER, push	2
100	51A796	FITTING, elbow, 90°, 1.5 in., triclover	2
101	15K040	NUT, regulator, metal	3
102	19A778	FITTING, run tee, swivel	1
103	19A777	FITTING, branch tee, swivel	1
104	19A795	FITTING, pipe, tee, st, 3/8, br	2
105	19A794	FITTING, elbow, 3/8nptm x 3/8nptf	1
106	19A820	FITTING, union, double stem	3
107	113802	SCREW, hex hd, flanged	3
108	121018	FITTING, elbow, male, swivel, 1/4 npt	1
109	128273	FITTING, barb x npt, brass	2
110	512905	FITTING, bulkhead	1
111	19A819	GROMMET	1
112+	-----	GAUGE, flange mount, 2.5 in., 200psi	3
113	18A426	FITTING, elbow, tube x nptf	3
114	19A776PKG	VALVE, 3-way, solenoid	2
115	19A878	FITTING, elbow, swivel, 1/2 x 3/8unf	1
116	17B998	BRACKET, EcoQuip, Datatrak	1
117	17K057	ENCLOSURE, Datatrak, EcoQuip	1
118	127846	FITTING, elbow, push-to-connect, 1/2	1
119	19A809	VALVE, stem and cartridge, 3-way	1
122	19A877	LABEL, clear, Media Trak	1
132★	25P358	CABLE, male plug (includes Ref. 136)	1
	130890	CAP (ATEX only)	3
133★	25P357	CABLE, female plug (includes Ref. 136)	2
134★	-----	CABLE, fuse holder	2
136	17L840	NUT, strain relief, 1/2 npt	3
137▲	25E860	LABEL, safety	1
138	127852	FITTING, elbow, swivel, push-to-connect	1
139◆	-----	NUT, regulator	1
141▲	15F744	LABEL, warning, pinch hazard	2

▲ Replacement safety labels, tags, and cards are available at no cost.

† Parts included in Auto Valve Kit 25P192 (purchase separately).

‡ Parts included in O-Ring and Piston Seal Kit 25P182 (purchase separately).

❖ Parts included in Air Regulator Kit 25P174 (purchase separately).

◆ Parts included in 3/8 npt Air Regulator Kit 25P179 (purchase separately).

✘ Parts included in Time Delay Kit 25P173 (purchase separately).

⊛ To repair this part, purchase the Diaphragm and Seals Kit 25N982PKG or the Spring Replacement Kit 25N983PKG.

+ Parts included in Flange Mount Gauge Kit 25P175 (purchase separately).

★ Parts included in Enclosure Cable Kit 25P190 (purchase separately).

\* To replace the internal filter inside of Ref. 47, purchase the Internal Filter Replacement Kit 24X967.

• Parts included in Air Regulator Kit 19Y249 (purchase separately).

## Blast Hoses

### Electric, 50 ft

28A024 (1.25 in.), 28A074 (1.0 in.)

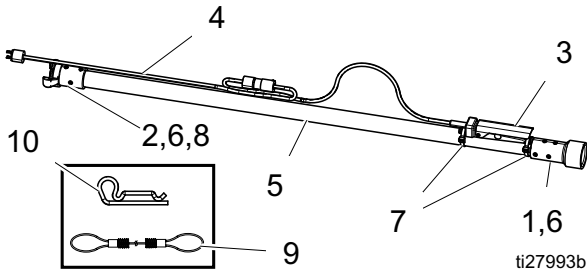


FIG. 47: Electric Blast Hose

### Electric Extension, 50 ft

28A026 (1.25 in.), 28A076 (1.0 in.)

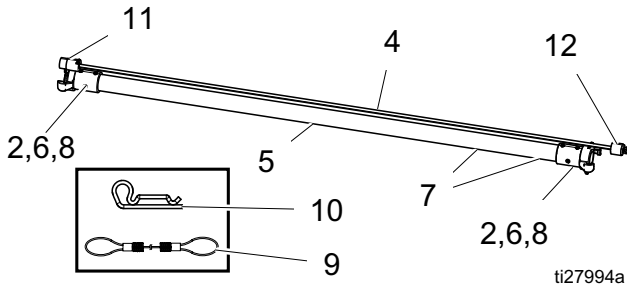


FIG. 48: Electric Blast Hose Extension

### Pneumatic, 50 ft

26A025 (1.25 in.), 26A075 (1.0 in.)

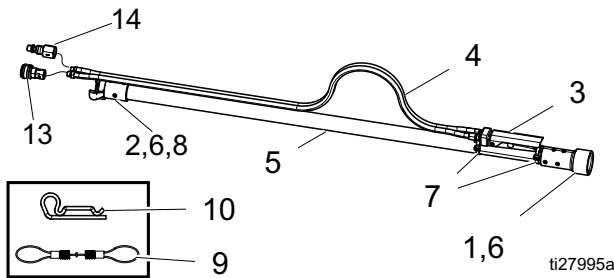


FIG. 49: Pneumatic Blast Hose

### Pneumatic Extension, 50 ft

26A027 (1.25 in.), 26A077 (1.0 in.)

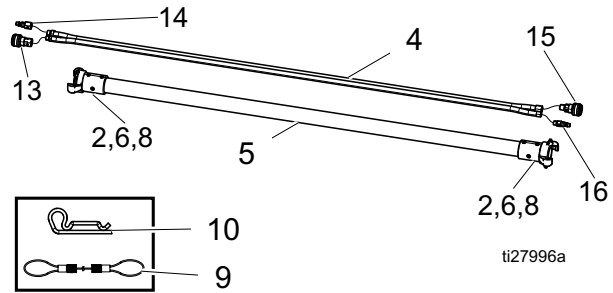


FIG. 50: Pneumatic Blast Hose Extension

Ref.	Part	Description	Qty
1	17L274	HOLDER, 1.25 in.	1
	17L276	HOLDER, 1.0 in.	1
2	17L273	COUPLER, 1.25 in.	1
	17L275	COUPLER, 1.0 in.	1
3	17D788	HANDLE, blast control switch, pneumatic	1
	17D791	HANDLE, switch, electric	1
4	24X746	HOSE, pneumatic, control, blast	1
	24X744	HOSE, pneumatic, control, extension	1
	17F506	CABLE, blast control	1
5	17L472	HOSE, blast, 1.25 in. ID	1
	17L473	HOSE, extension, 1.25 in. ID	1
	17L474	HOSE, blast, 1.0 in. ID	1
	17L475	HOSE, extension, 1.0 in ID	1
6	17L476	KIT, screws, flat hd, sst, 8 pk	1
7	17H240	KIT, cable ties, 6 pk	1
8	17C124	GASKET, brass, blast coupler	1
9	17D786	KIT, replacement, whip check	1
10	17D787	KIT, replacement, hairpin, hose	1
11	EQ1863	CONNECTOR, twist-lock, m	1
12	EQ1864	CONNECTOR, twist-lock, f	1
13	EQ1336	1/4 QD(f), 1/8 npt(f)	1
14	EQ1421	1/4 QD(m), 1/4 npt(f)	1
15	EQ1813	1/4 QD9f), 1/4 npt(m)	1
16	EQ1823	1/4 QD(m), 1/8 npt(m)	1

## Tubing

Color	Part	Outer Diameter
Natural (Clear)	EQ1273	3/8 (0.375) in.
Natural (Clear)	EQ1881	1/4 (0.25) in.
Red	EQ1297	3/8 (0.375) in.
Red	EQ1882	1/4 (0.25) in.
Green	EQ1884	1/4 (0.25) in.
Green	054757	5/32 (0.156) in.
Orange	EQ1296	1/4 (0.25) in.
Yellow	EQ1885	1/4 (0.25) in.
Blue	EQ1883	1/4 (0.25) in.
Black	061513	1/2 (0.5) in.

## Kits and Accessories

### Blast Hoses with Control Hose/Cable

Part	ID	Blast Control	Coupler 1	Coupler 2	Length	ATEX Approved
26A077	1.0 in.	Pneumatic	2-Prong coupler, brass	2-Prong coupler, brass	15 m (50 ft)	Yes
28A076	1.0 in.	Electric	2-Prong coupler, brass			No
26A075	1.0 in.	Pneumatic	Nozzle holder, brass			Yes
28A074	1.0 in.	Electric	Nozzle holder, brass			No
28A028	1.25 in.	Electric	2-Prong coupler, brass			No
26A027	1.25 in.	Pneumatic	2-Prong coupler, brass			Yes
26A025	1.25 in.	Pneumatic	Nozzle holder, brass			Yes
28A024	1.25 in.	Electric	Nozzle holder, brass			No

### Blast Hoses without Control Hose/Cable

Part	ID	Blast Control	Coupler 1	Coupler 2	Length	ATEX Approved
17L474	1.0 in.	None	Nozzle holder, brass	2-Prong coupler, brass	15 m (50 ft)	Yes
17L475	1.0 in.		2-Prong coupler, brass			
17L472	1.25 in.		Nozzle holder, brass			
17L473	1.25 in.		2-Prong coupler, brass			

### Control Hoses/Cable with Blast Hose

Part	Description
24X746	Blast control hose, pneumatic control line, 55 ft, ATEX approved
24X744	Blast control hose, pneumatic control line, 55 ft, extension, ATEX approved
17F506	Blast control cable, electric, 55 ft

### Nozzles

Part	Description	Length	Thread Size
17J859	Nozzle, #7 standard	7.8 in.	50 mm Contractor Thread (2 in. 4-1/2 UNC-2A)
17J860	Nozzle, #8 standard	8.8 in.	
17J861	Nozzle, #10 standard	9.0 in.	
17J862	Nozzle, #12 standard	9.0 in.	
17K898	Nozzle, #6 high performance*	12.0 in.	
17J855	Nozzle, #7 high performance*	12.0 in.	
17J856	Nozzle, #8 high performance*	12.0 in.	
17J858	Nozzle, #10 high performance*	12.0 in.	

\* High performance nozzles require 100 psi (7 bar, 0.7 MPa) or more air pressure at nozzle.



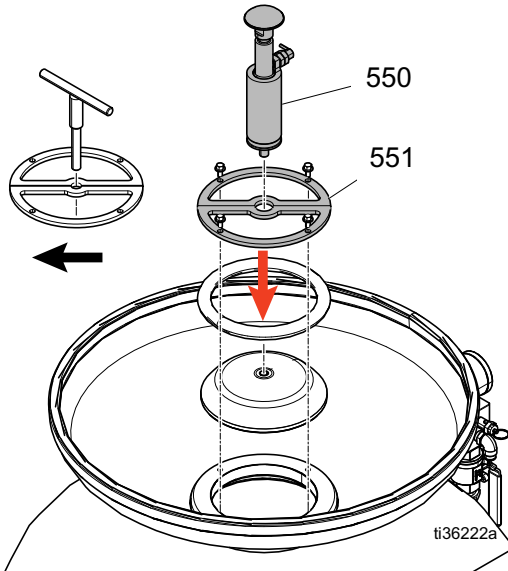
## Common Spare Parts

Part	Description
17D786	Hose restraint / whip check
17D787	Blast hose coupler pin kit (6 pack)
17C124	Grommet, hose coupler. Fits either 1.0 in. or 1.25 in. diameter hose
17L309	Gasket, abrasive hose cam lock (10 pack)
17L119	Gasket, blast nozzle (5 pack)
17L313	Blast circuit gasket kit (10 pack)
26A093	Water tank filter with adapter (5 pack)
206994	Throat seal liquid (TSL)
17B186	Pump repair, lower
17C131	Main air regulator diaphragm repair kit
17F535	Air regulator piston repair kit
17F536	Air regulator o-ring repair kit
17L310	O-ring, pot seal plunger
17D790	Gasket, handway
17L333	Pump, inlet filter replacement
EQ1818	Air filter, replacement, inside enclosure
17K051	Short pinch hose replacement kit
19A746PKG	Long pinch hose replacement kit
17L046	Abrasive ball valve replacement
18B807PKG	Abrasive ball valve seal repair kit
18B805PKG	1-1/4 ball valve seal repair kit

## Other Accessories

Part	Description
17L119	KIT, nozzle gasket (pack of 5)
EQ5166	KIT, nozzle extension, 24 in. (0.6 m)
26A029	KIT, nozzle extension, 24 in. (0.6 m), with handles
17K025	KIT, pot strainer
17K045	KIT, water tank inlet with float valve
17L316	KIT, garden hose inlet and pressure regulator
24Z156	KIT, tool box with insert
17D686	KIT, door stay
EQ1907	LID, tank, 5 in., vented, 2-way

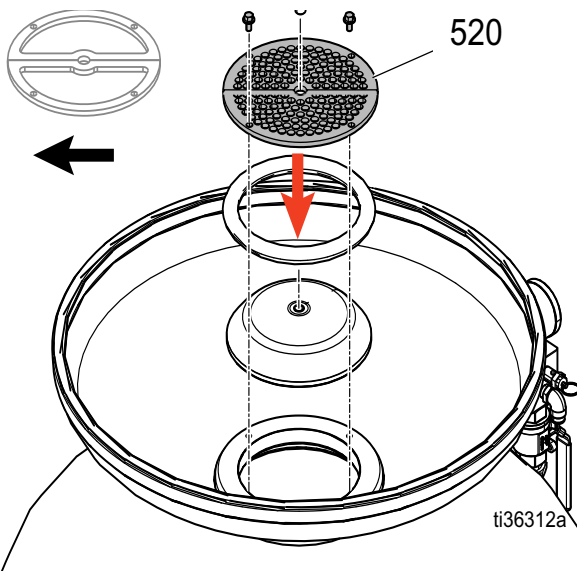
**Pop-Up Plunger Kit (25E874)**



**FIG. 51: Pop-Up Plunger Kit**

Ref.	Description	Qty.
550	ASSEMBLY, pop-up plunger	1
551	ASSEMBLY, bracket, pop-up, D-ring	1

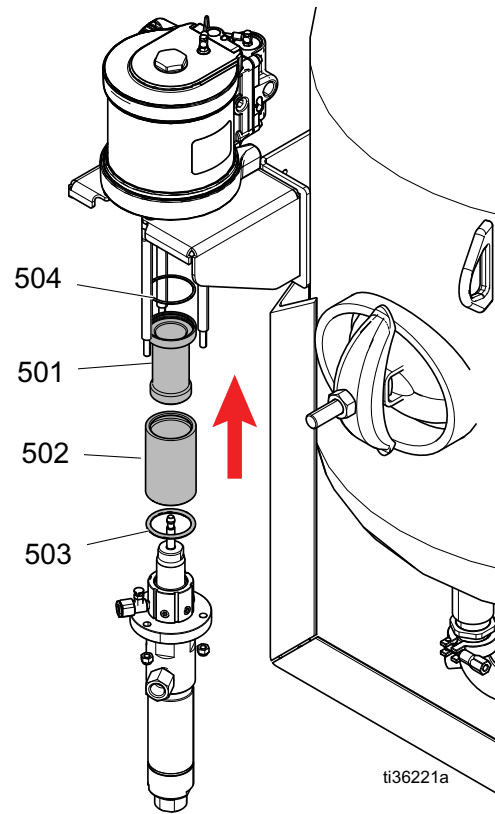
**Pressure Pot Strainer Kit (18A847)**



**FIG. 52: Pressure Pot Strainer Kit**

Ref.	Description	Qty.
520	STRAINER, pressure pot, 0.25	2
521	BOLT, flange hd, serrated, 1/4, ss	4

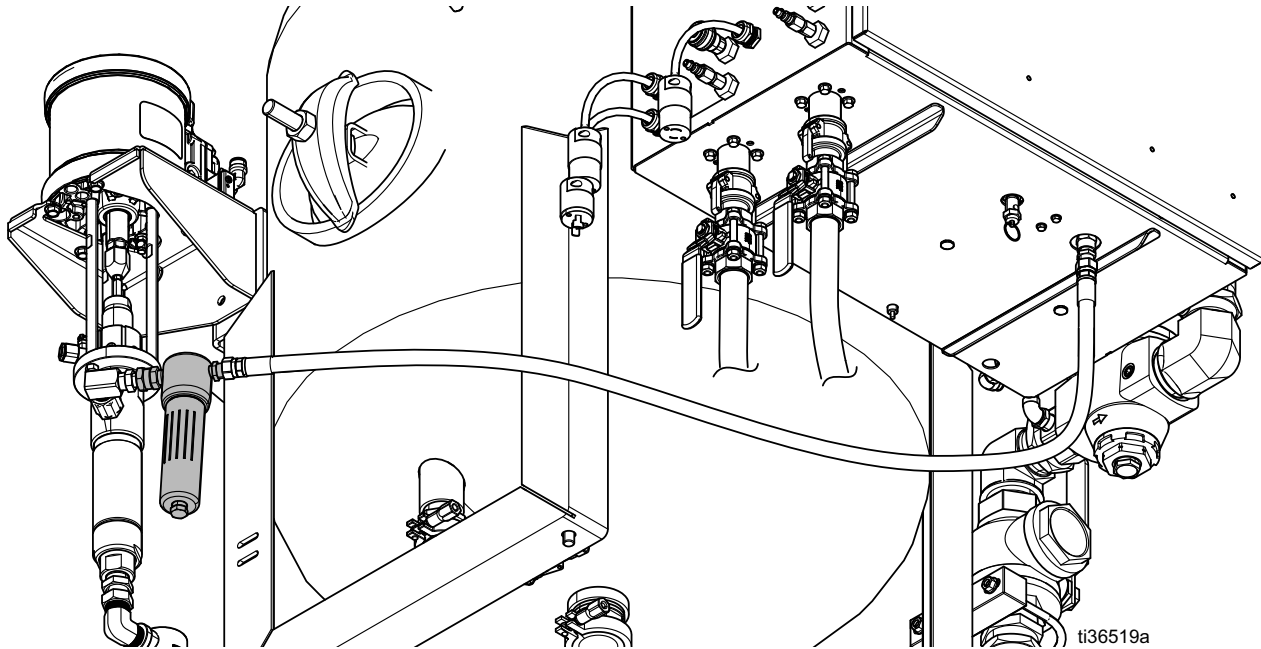
**Tube Guard Kit (25P158)**



**FIG. 53: Tube Guard Kit**

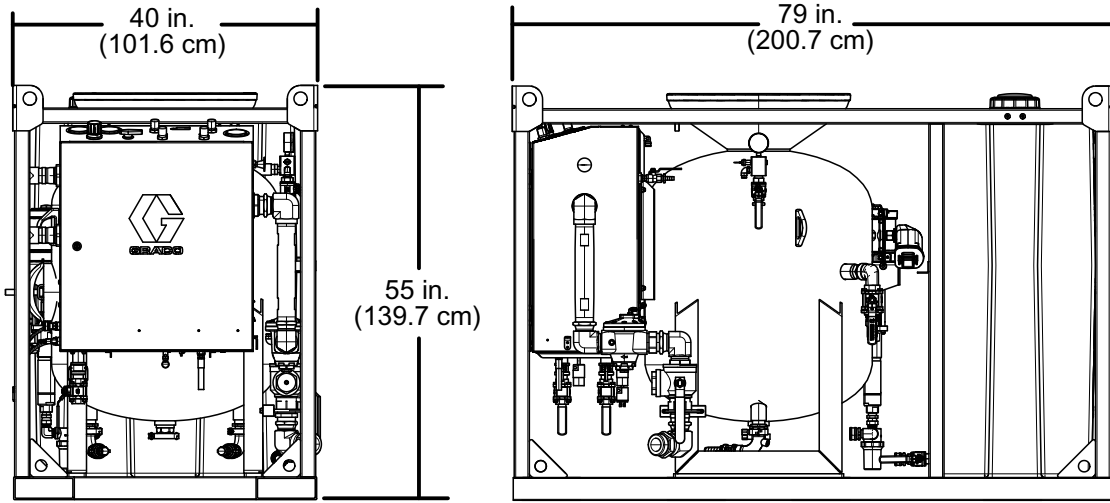
Ref.	Description	Qty.
501	GUARD, tube, telescope, top	1
502	GUARD, tube, telescope, bottom	1
503	O-RING, buna, 139	1
504	PACKING, o-ring	1

**Pump Output Water Filter Kit (25P367PKG)**



# Dimensions

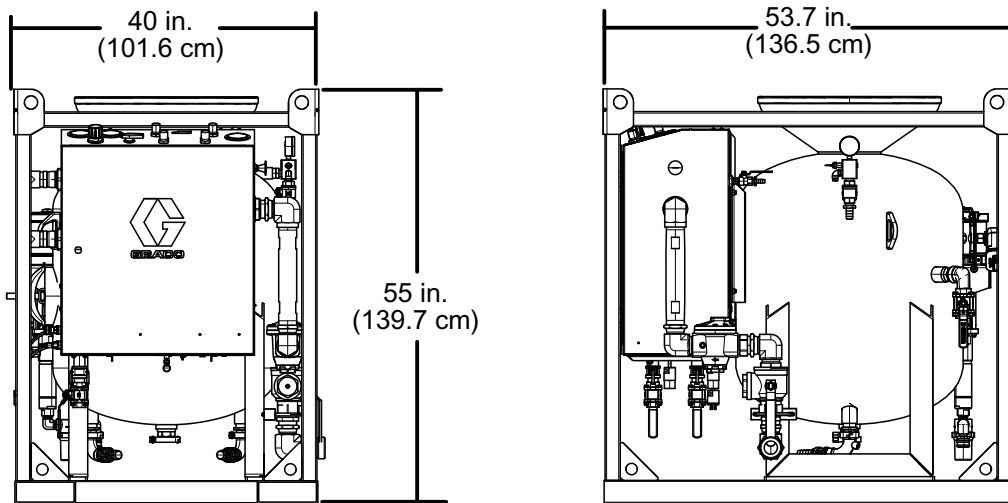
## EcoQuip 2 EQs Dual Line with Water Tank



ti36539a

Dimension	US	Metric
Length	79 in.	200.7 cm
Width	40 in.	101.6 cm
Height	55 in.	139.7 cm

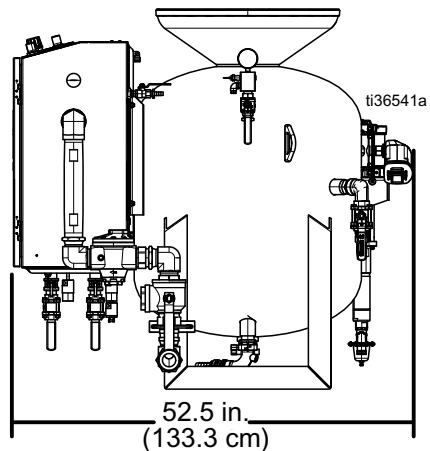
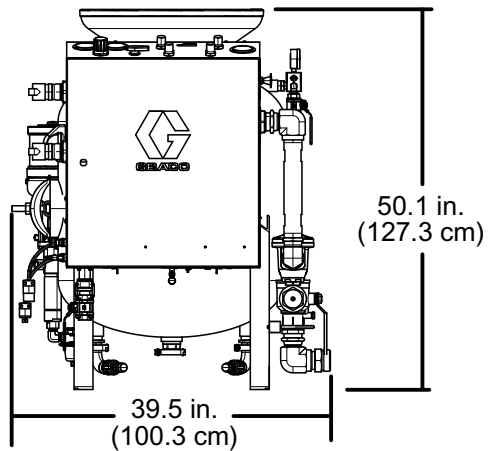
## EcoQuip 2 EQs Dual Line



ti36540a

Dimension	US	Metric
Length	53.7 in.	136.5 cm
Width	40 in.	101.6 cm
Height	55 in.	139.7 cm

# EcoQuip 2 EQc Dual Line



Dimension	US	Metric
Length	52.5 in.	133.3 cm
Width	39.5 in.	100.3 cm
Height	50.1 in.	127.3 cm

# Technical Specifications

<b>EcoQuip 2 Dual Line Vapor Abrasive Blast System</b>		
	<b>US</b>	<b>Metric</b>
Maximum fluid working pressure	150 psi	10.3 bar, 1.03 MPa
Operating temperature	35°-110° F	1.6°-43.3° C
Recommended compressor size*	750-1600 SCFM	22-45 m <sup>3</sup> /min
Blast hose size (supplied)	1.25 in. ID	31.75 mm ID
Abrasive capacity†	1665 lb	755 kg
Dry weight	1326 lb	601 kg
Maximum wet weight	4150 lb	1882 kg
Pressure pot volume	12 cubic feet	0.34 cubic meters
Water tank volume	115 gallons	435 liters
Air inlet connection‡	2 in. ground join (Boss™ fitting)	
Air supply hose minimum ID	2 in. ID	51 mm ID
<b>Noise (dBa)</b>		
Sound pressure	133 dBa @ 150 psi (10.3 MPa, 1.03 bar)	
Sound power	139 dBa @ 150 psi (10.3 MPa, 1.03 bar)	
Instantaneous sound pressure	131 dBa @ 150 psi (10.3 MPa, 1.03 bar)	
<i>Sound pressure measured from the operator position. The abrasive used was garnet and the substrate was steel.</i>		
<i>Sound power measured per ISO 9614-2.</i>		
<b>Notes</b>		
* See <b>Nozzle Selection Guide</b> , page 23, for information on properly selecting the blast nozzle based on compressor pressure and flow output specifications.		
† Abrasive capacity was found using 30/60 grit garnet. Using coarser media or less dense media will decrease the weight.		
‡ 2 in. ground boss adapter included in tool box.		
All trademarks or registered trademarks are the property of their respective owners.		

## California Proposition 65

### CALIFORNIA RESIDENTS

 **WARNING:** Cancer and reproductive harm – [www.P65warnings.ca.gov](http://www.P65warnings.ca.gov).



# Graco Standard Warranty

Graco warrants all equipment referenced in this document which is manufactured by Graco and bearing its name to be free from defects in material and workmanship on the date of sale to the original purchaser for use. With the exception of any special, extended, or limited warranty published by Graco, Graco will, for a period of twelve months from the date of sale, repair or replace any part of the equipment determined by Graco to be defective. This warranty applies only when the equipment is installed, operated and maintained in accordance with Graco's written recommendations.

This warranty does not cover, and Graco shall not be liable for general wear and tear, or any malfunction, damage or wear caused by faulty installation, misapplication, abrasion, corrosion, inadequate or improper maintenance, negligence, accident, tampering, or substitution of non-Graco component parts. Nor shall Graco be liable for malfunction, damage or wear caused by the incompatibility of Graco equipment with structures, accessories, equipment or materials not supplied by Graco, or the improper design, manufacture, installation, operation or maintenance of structures, accessories, equipment or materials not supplied by Graco.

This warranty is conditioned upon the prepaid return of the equipment claimed to be defective to an authorized Graco distributor for verification of the claimed defect. If the claimed defect is verified, Graco will repair or replace free of charge any defective parts. The equipment will be returned to the original purchaser transportation prepaid. If inspection of the equipment does not disclose any defect in material or workmanship, repairs will be made at a reasonable charge, which charges may include the costs of parts, labor, and transportation.

**THIS WARRANTY IS EXCLUSIVE, AND IS IN LIEU OF ANY OTHER WARRANTIES, EXPRESS OR IMPLIED, INCLUDING BUT NOT LIMITED TO WARRANTY OF MERCHANTABILITY OR WARRANTY OF FITNESS FOR A PARTICULAR PURPOSE.**

Graco's sole obligation and buyer's sole remedy for any breach of warranty shall be as set forth above. The buyer agrees that no other remedy (including, but not limited to, incidental or consequential damages for lost profits, lost sales, injury to person or property, or any other incidental or consequential loss) shall be available. Any action for breach of warranty must be brought within two (2) years of the date of sale.

**GRACO MAKES NO WARRANTY, AND DISCLAIMS ALL IMPLIED WARRANTIES OF MERCHANTABILITY AND FITNESS FOR A PARTICULAR PURPOSE, IN CONNECTION WITH ACCESSORIES, EQUIPMENT, MATERIALS OR COMPONENTS SOLD BUT NOT MANUFACTURED BY GRACO.** These items sold, but not manufactured by Graco (such as electric motors, switches, hose, etc.), are subject to the warranty, if any, of their manufacturer. Graco will provide purchaser with reasonable assistance in making any claim for breach of these warranties.

In no event will Graco be liable for indirect, incidental, special or consequential damages resulting from Graco supplying equipment hereunder, or the furnishing, performance, or use of any products or other goods sold hereto, whether due to a breach of contract, breach of warranty, the negligence of Graco, or otherwise.

## **FOR GRACO CANADA CUSTOMERS**

The Parties acknowledge that they have required that the present document, as well as all documents, notices and legal proceedings entered into, given or instituted pursuant hereto or relating directly or indirectly hereto, be drawn up in English. Les parties reconnaissent avoir convenu que la rédaction du présente document sera en Anglais, ainsi que tous documents, avis et procédures judiciaires exécutés, donnés ou intentés, à la suite de ou en rapport, directement ou indirectement, avec les procédures concernées.

# Graco Information

For the latest information about Graco products, visit [www.graco.com](http://www.graco.com).

For patent information, see [www.graco.com/patents](http://www.graco.com/patents).

**TO PLACE AN ORDER**, contact your Graco distributor or call to identify the nearest distributor.

**Phone:** 612-623-6921 **or Toll Free:** 1-800-328-0211, **Fax:** 612-378-3505

*All written and visual data contained in this document reflects the latest product information available at the time of publication. Graco reserves the right to make changes at any time without notice.*

Original instructions. This manual contains English. MM 3A6825

**Graco Headquarters:** Minneapolis

**International Offices:** Belgium, China, Japan, Korea

**GRACO INC. AND SUBSIDIARIES • P.O. BOX 1441 • MINNEAPOLIS MN 55440-1441 • USA**  
**Copyright 2021, Graco Inc. All Graco manufacturing locations are registered to ISO 9001.**

[www.graco.com](http://www.graco.com)  
Revision H, August 2024