

# G-MINI<sup>®</sup> Pump

3A6714J

EN

*For dispensing NLGI Grades #000 to #2 greases and oils with at least 40 cSt. For professional use only.*

**Not approved for use in explosive atmospheres or hazardous (classified) locations.**

**Models, pages 3 and 4.**

*4061 psi (28 MPa, 280 bar) Maximum Working Pressure*



## **Important Safety Instructions**

Read all warnings and instructions in this manual before using the equipment. Be familiar with the proper control and usage of the equipment. Save these instructions.

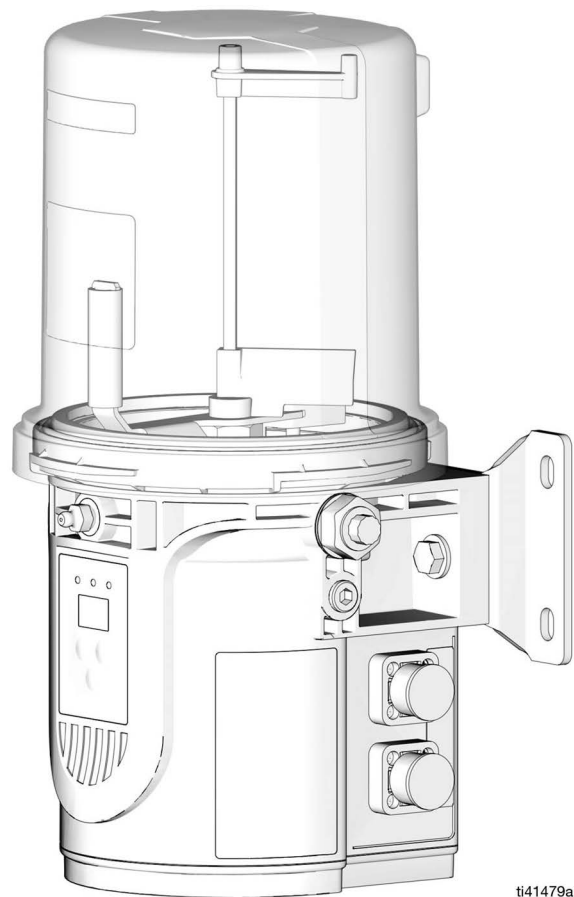

ti41479a



Conforms to ANSI/UL 73  
Certified to CAN/CSA  
Std. 22.2 No 68-09



110-240VAC Pumps ONLY

# Contents

<b>Models</b> .....	<b>3</b>	<b>Operation</b> .....	<b>23</b>
DC Models.....	3	Non Controller Operation.....	23
AC Models.....	4	Low-Level Output Option.....	23
<b>Safety Symbols</b> .....	<b>5</b>	Controller Operation.....	25
<b>General Warnings</b> .....	<b>6</b>	Control Panel Overview (FIG. 29).....	25
<b>Typical Installation</b> .....	<b>8</b>	RUN MODE.....	26
Component Identification.....	8	SETUP MODE.....	26
Divider Installation Remote.....	9	ON TIME Configuration (Minutes).....	26
CSP Direct Mount Installation.....	9	ON TIME Configuration (Cycles).....	27
<b>Installation</b> .....	<b>10</b>	OFF TIME Configuration (Min./Hrs).....	28
Choose an Installation Location.....	10	ADVANCED PROGRAMMING.....	28
System Configuration and Wiring.....	11	Advanced Programming Menu	
Ground (AC Models Only).....	11	Descriptions.....	29
Fuses.....	11	Alerts and Alarms.....	32
Recommendations for Pump Usage		Alerts.....	32
in Harsh Environments.....	12	Alarms.....	32
Wiring and Installation Diagrams.....	12	Alert and Alarm Scenarios.....	33
Power CPC DC - 5 Wire (Non-Controller) ..	13	<b>Maintenance</b> .....	<b>34</b>
Power CPC DC - 5 Wire (Controller).....	13	<b>Recycling and Disposal</b> .....	<b>35</b>
Power CPC DC - 2 Wire (Non-Controller) ..	14	End of Product Life.....	35
Power DIN DC - 15 ft Power Cable.....	14	<b>Troubleshooting</b> .....	<b>36</b>
Power DIN AC.....	15	<b>Repair</b> .....	<b>37</b>
Low Level DIN DC.....	15	Reservoir Kits.....	37
Divider Valve Indicator Cycle Inputs (M12) .	16	Pump Element Kits.....	37
Part No. 124333: Cable Pin Out (M12) for		<b>Parts</b> .....	<b>38</b>
5 m Cable.....	16	Grease Model 1 L and 0.5 L.....	38
Manual Run Button.....	16	Grease Model 2 L.....	39
Manual Run Button DIN DC.....	17	Oil Model 1 L.....	40
Proximity Switch.....	17	Oil Model 2 L.....	41
<b>Setup</b> .....	<b>18</b>	<b>Dimensions</b> .....	<b>43</b>
Pressure Relief Procedure.....	18	CSP Valve Bracket Mount.....	44
Connect to Auxiliary Fittings.....	18	2 L Model Pump Mount.....	44
Pressure Relief Valves.....	18	0.5 L and 1 L Model Pump Mount.....	44
Pressure Relief Valves.....	18	Universal Bracket Mount.....	44
Set Pump Outlet Volume.....	19	<b>Technical Specifications</b> .....	<b>45</b>
Fill Reservoir - Grease Dispense Pumps.....	19	<b>California Proposition 65</b> .....	<b>45</b>
Models With a Follower Plate.....	20	<b>Graco Standard Warranty</b> .....	<b>46</b>
Models Without a Follower Plate.....	20		
Change Greases.....	21		
Fill Reservoir - Oil Dispense Pumps.....	21		
Prime the Pump.....	21		

# Models

## DC Models







Model	Fluid Type	Reservoir			Controller	Voltage		Power Input	Follower Plate	Cycle Feedback Input	Pump Element Quantity	Heater
		0.5 L	1 L	2 L		12VDC	24VDC					
25R800	Grease		X				X	CPC	X		1	
25R801	Grease		X		X		X	CPC	X	M12	1	
25R802	Grease		X			X		CPC	X		1	
25R803	Grease		X		X	X		CPC	X	M12	1	
25R804	Grease		X		X		X	CPC	X	M12	1	X
25R805	Grease		X		X		X	CPC	X	M12	2	X
25R806	Grease		X		X	X		CPC	X	M12	1	X
25R807	Grease	X					X	CPC	X		1	
25R808	Grease	X			X		X	CPC	X	M12	1	
25R809	Grease	X				X		CPC	X		1	
25R810	Grease	X			X	X		CPC	X	M12	1	
25R811	Grease		X				X	CPC			1	
25R812	Grease		X			X		CPC			1	
25R813	Grease		X		X		X	CPC		M12	1	
25R814	Grease		X		X	X		CPC		M12	1	
25R815	Grease		X				X	DIN			1	
25R816	Grease		X			X		DIN			1	
25R817	Grease		X		X		X	DIN		M12	1	
25R818	Grease		X		X	X		DIN		M12	1	
25R820	Grease		X				X	DIN	X		1	
25R821	Grease		X		X		X	DIN	X	M12	1	
25R822	Grease		X			X		DIN	X		1	
25R823	Grease		X		X	X		DIN	X	M12	1	
25R824	Grease		X		X		X	DIN	X	M12	1	X
25R825	Grease		X		X		X	DIN	X	M12	2	X
25R826	Grease		X		X	X		DIN	X	M12	1	X
25R827	Grease	X					X	DIN	X		1	
25R828	Grease	X			X		X	DIN	X	M12	1	
25R829	Grease	X				X		DIN	X		1	
25R830	Grease	X			X	X		DIN	X	M12	1	
25R831	Grease			X			X	CPC			1	
25R832	Grease			X		X		CPC			1	
25R833	Grease			X	X		X	CPC		M12	1	
25R834	Grease			X	X	X		CPC		M12	1	
25R835	Grease			X			X	DIN			1	
25R836	Grease			X		X		DIN			1	
25R837	Grease			X	X		X	DIN		M12	1	
25R838	Grease			X	X	X		DIN		M12	1	
2000634	Oil		X				X	DIN			1	
2000636	Oil		X		X		X	DIN		M12	1	
2000638	Oil			X			X	DIN			1	
2000640	Oil			X	X		X	DIN		M12	1	

## AC Models

Model	Fluid Type	Reservoir			Controller	Power Input	Follower Plate	Cycle Feedback Input	Heater
		0.5 L	1 L	2 L					
2000643	Grease	X				DIN	X		
2000644	Grease	X			X	DIN	X	M12	
2000645	Grease		X			DIN	X		
2000646	Grease		X		X	DIN	X	M12	
2000647	Grease		X		X	DIN	X	M12	X
2000648	Grease		X			DIN			
2000649	Grease		X		X	DIN		M12	
2000650	Grease			X		DIN			
2000651	Grease			X	X	DIN		M12	
2000635	Oil		X			DIN			
2000637	Oil		X		X	DIN		M12	
2000639	Oil			X		DIN			
2000641	Oil			X	X	DIN		M12	

# Safety Symbols

The following safety symbols appear throughout this manual and on warning labels. Read the table below to understand what each symbol means.

Symbol	Meaning
	Cleaning Solvent Hazard
	Electric Shock Hazard
	Equipment Misuse Hazard
	Fire and Explosion Hazard
	Moving Parts Hazard
	Skin Injection Hazard
	Skin Injection Hazard

Symbol	Meaning
	Splash Hazard
	Do Not Place Hands or Other Body Parts Near Fluid Outlet
	Do Not Stop Leaks with Hand, Body, Glove or Rag
	Follow Pressure Relief Procedure
	Ground Equipment
	Read Manual
	Wear Personal Protective Equipment











## Safety Alert Symbol









This symbol indicates: Attention! Become Alert! Look for this symbol throughout the manual to indicate important safety messages.

# General Warnings

The following warnings apply throughout this manual. Read, understand, and follow the warnings before using this equipment. Failure to follow these warnings can result in serious injury.

 <h1 style="margin: 0;">WARNING</h1>	
 	<p><b>ELECTRIC SHOCK HAZARD</b></p> <p>This equipment must be grounded. Improper grounding, setup, or usage of the system can cause electric shock.</p> <ul style="list-style-type: none"> <li>• Turn off and disconnect all power before disconnecting any cables and before servicing or installing equipment.</li> <li>• Connect only to grounded power source.</li> <li>• All electrical wiring must be done by a qualified electrician and comply with all local codes and regulations.</li> </ul>
    	<p><b>SKIN INJECTION HAZARD</b></p> <p>High-pressure fluid from dispensing device, hose leaks, or ruptured components will pierce skin. This may look like just a cut, but it is a serious injury that can result in amputation. <b>Get immediate surgical treatment.</b></p> <ul style="list-style-type: none"> <li>• Do not point dispensing device at anyone or at any part of the body.</li> <li>• Do not put your hand over the fluid outlet.</li> <li>• Do not stop or deflect leaks with your hand, body, glove, or rag.</li> <li>• Follow the <b>Pressure Relief Procedure</b> when you stop dispensing and before cleaning, checking, or servicing equipment.</li> <li>• Tighten all fluid connections before operating the equipment.</li> <li>• Check hoses and couplings daily. Replace worn or damaged parts immediately.</li> </ul>

# ! WARNING

 	<p><b>EQUIPMENT MISUSE HAZARD</b></p> <p>Misuse can cause death or serious injury.</p> <ul style="list-style-type: none"> <li>• Do not operate the unit when fatigued or under the influence of drugs or alcohol.</li> <li>• Do not exceed the maximum working pressure or temperature rating of the lowest rated system component. See <b>Technical Specifications</b> in all equipment manuals.</li> <li>• Use fluids and solvents that are compatible with equipment wetted parts. See <b>Technical Specifications</b> in all equipment manuals. Read fluid and solvent manufacturer’s warnings. For complete information about your material, request Safety Data Sheets (SDSs) from distributor or retailer.</li> <li>• Turn off all equipment and follow the <b>Pressure Relief Procedure</b> when equipment is not in use.</li> <li>• Check equipment daily. Repair or replace worn or damaged parts immediately with genuine manufacturer’s replacement parts only.</li> <li>• Do not alter or modify equipment. Alterations or modifications may void agency approvals and create safety hazards.</li> <li>• Make sure all equipment is rated and approved for the environment in which you are using it.</li> <li>• Use equipment only for its intended purpose. Call your distributor for information.</li> <li>• Route hoses and cables away from traffic areas, sharp edges, moving parts, and hot surfaces.</li> <li>• Do not kink or over bend hoses or use hoses to pull equipment.</li> <li>• Keep children and animals away from work area.</li> <li>• Comply with all applicable safety regulations.</li> </ul>
 	<p><b>PRESSURIZED EQUIPMENT HAZARD</b></p> <p>Over-pressurization can result in equipment rupture and serious injury.</p> <ul style="list-style-type: none"> <li>• A pressure relief valve is required at each pump outlet.</li> <li>• Follow the <b>Pressure Relief Procedure</b> in this manual when servicing equipment.</li> </ul>
 	<p><b>PLASTIC PARTS CLEANING SOLVENT HAZARD</b></p> <p>Many cleaning solvents can degrade plastic parts and cause them to fail, which could cause serious injury or property damage.</p> <ul style="list-style-type: none"> <li>• Use only compatible solvents to clean plastic structural or pressure-containing parts.</li> <li>• See <b>Technical Specifications</b> in all equipment manuals for materials of construction. Consult the solvent manufacturer for information and recommendations about compatibility.</li> </ul>
 	<p><b>MOVING PARTS HAZARD</b></p> <p>Moving parts can pinch, cut or amputate fingers and other body parts.</p> <ul style="list-style-type: none"> <li>• Keep clear of moving parts.</li> <li>• Do not operate equipment with protective guards or covers removed.</li> <li>• Equipment can start without warning. Before checking, moving, or servicing equipment, follow the <b>Pressure Relief Procedure</b> and disconnect all power sources.</li> </ul>
	<p><b>PERSONAL PROTECTIVE EQUIPMENT</b></p> <p>Wear appropriate protective equipment when in the work area to help prevent serious injury, including eye injury, hearing loss, inhalation of toxic fumes, and burns. Protective equipment includes but is not limited to:</p> <ul style="list-style-type: none"> <li>• Protective eyewear, and hearing protection.</li> <li>• Respirators, protective clothing, and gloves as recommended by the fluid and solvent manufacturer.</li> </ul>

# Typical Installation

## Component Identification

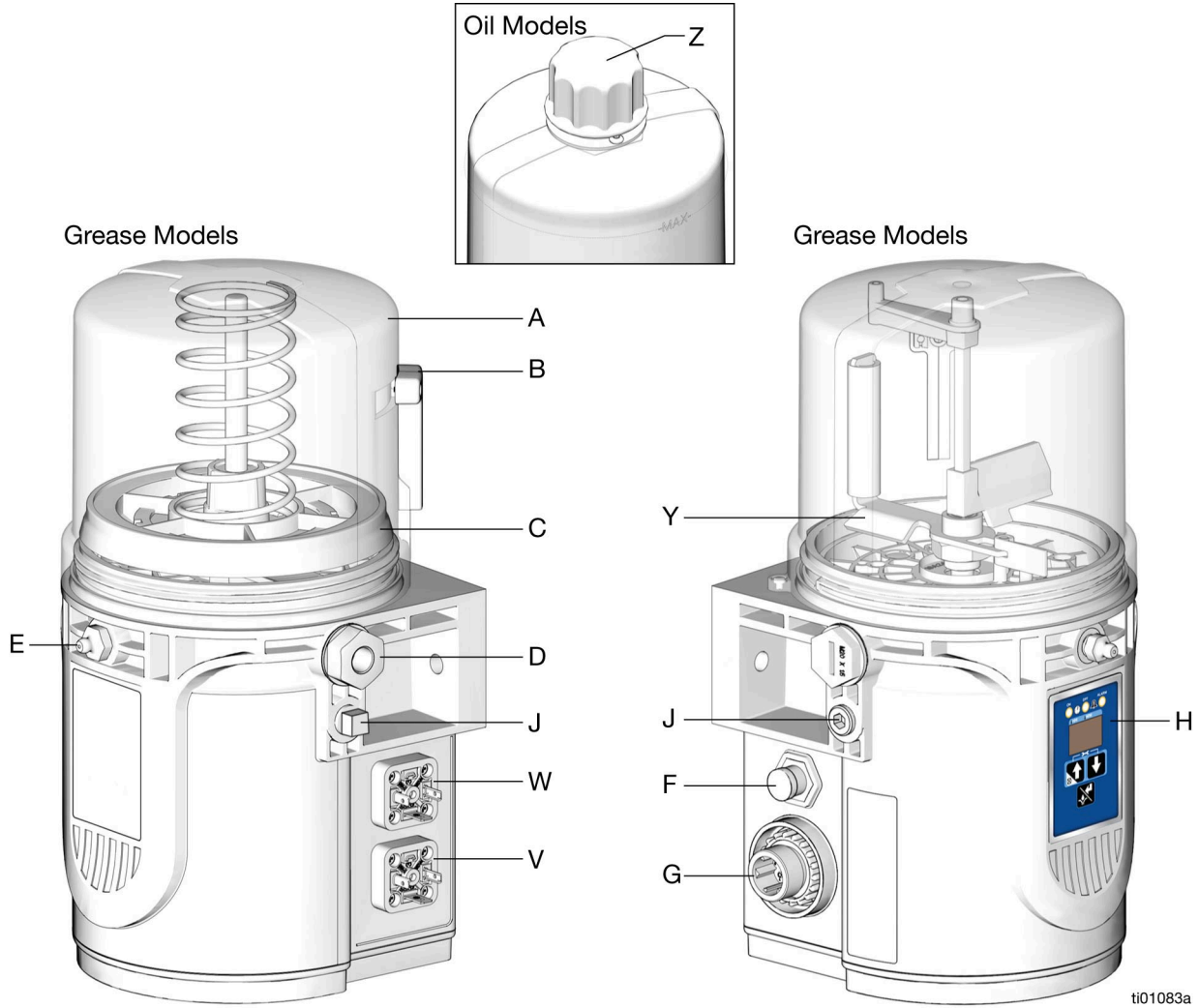

**FIG. 1:**

**Key:**

- A Reservoir
- B Venting Tube (1 Liter and 0.5 Liter models only)
- C Follower Plate (not available on all models)
- D Pump Element
- E Zerk Inlet Fill Fitting
- F Cycle Indicator Connector (Controller model only)
- G CPC Connector
- H Controller
- J Return to Reservoir
- V DIN Connector (Power)
- W DIN Connector (Low level/Manual run button)
- Y Stirring Paddle (not available on all models)
- Z Top Fill Lid



## Divider Installation Remote

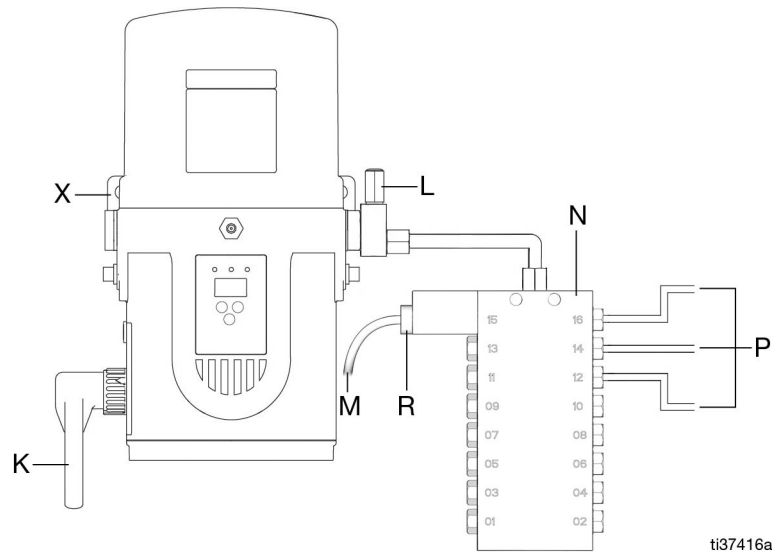

ti37416a

FIG. 2:

## CSP Direct Mount Installation

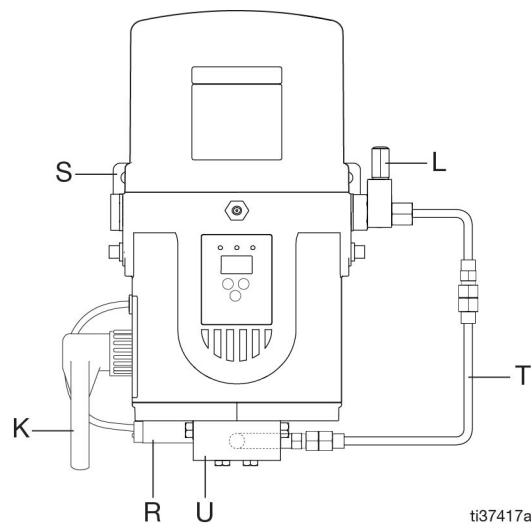

ti37417a

FIG. 3:

- K Connection to fused power source (DC Models only)
- L Pressure relief valve (required for each outlet)\*  
See **Pressure Relief Valves**, page 18
- M Proximity switch cable
- N Series progressive divider valves (Divider Installation)
- P Connection to lube points
- R Proximity switch, see page 17
- S Direct Mount CSP Bracket, see page 10
- T Direct Mount CSP Hose, see page 10
- U CSP valves
- X Universal Bracket, see page 10

\*User Supplied

3A6714J

# Installation

## Choose an Installation Location



### AUTOMATIC SYSTEM ACTIVATION HAZARD

Unexpected activation of the system could result in serious injury, including skin injection and amputation.

This device has an automatic timer that activates the pump lubrication system when power is connected or when exiting the programming function. Before installation or removal of the lubrication pump from the system, disconnect and isolate all power supplies and relieve all pressure.

- Select a location that will support the weight of the pump and lubricant, as well as all plumbing and electrical connections.
- Refer to the two mounting hole layouts provided in the **Dimensions** section of this manual, page 44.
- Use designated mounting holes and provided configurations only.
- Use the two fasteners (included) to secure the pump to the mounting surface.

Some installations may require an additional pump bracket.

### Mounting Bracket Kits

Part No	Description
26C826	Universal Bracket (fastener included)
26C825	Direct Mount CSP Bracket (fastener included)

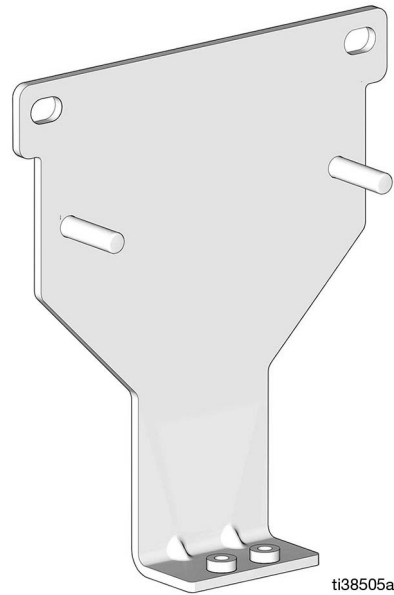

FIG. 4: 26C826

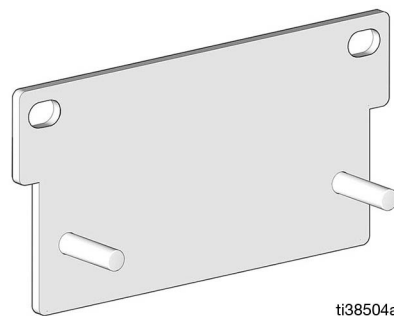

FIG. 5: 26C825

### Direct Mount CSP Hose Kit

Part No	Description
26C956	1/4 NPT (Pressure Relief Outlet) to 1/8 NPT (CSP Inlet), includes hose (25 cm length), fitting 17T781 and 17T783

## System Configuration and Wiring



All electrical wiring must be done by a qualified electrician and comply with all local codes and regulations.

### Ground (AC Models Only)



The equipment must be grounded to reduce the risk of static sparking and electric shock. Electric or static sparking can cause fumes to ignite or explode. Improper grounding can cause electric shock. Grounding provides an escape wire for the electric current.

Improper installation of the grounding conductor may result in a risk of electric shock. This product must be installed by a qualified electrician in compliance with all state and local codes and regulations.

If the product is permanently connected, it must be:

- Installed by a qualified electrician or service personnel.
- Connected to a grounded, permanent wiring system.

If an attachment plug is required in the end use application:

- It must be rated for the product electrical specifications.
- It must be an approved, 3-wire ground type attachment plug.
- It must be plugged into an outlet properly installed and grounded in accordance with all local codes and ordinances.

- When repair or replacement of the power cord or plug is required, do not connect the grounding wire to either flat blade terminal.

## Fuses

### NOTICE

Fuses (user supplied) are required on all DC models. To avoid equipment damage:

- Never operate pump DC models without a fuse installed.
- A fuse of the correct current rating must be installed in line with the power entry to the equipment.

Fuse kits are available from Graco. The kit table, shown on page 12, identifies the correct fuse for the input voltage and the corresponding Graco Kit number.

Kit Table

Fuse Value	Graco Kit No.	Applicable Model
10A	26C916	25R802
		25R803
		25R806
		25R809
		25R810
		25R812
		25R814
		25R816
		25R818
		25R822
		25R823
		25R826
		25R829
		25R730
		25R832
		25R834
		25R836
		25R838
5A	26C917	25R800
		25R807
		25R811
		25R815
		25R820
		25R827
		25R831
		25R835
		2000634
		2000638
		7.5A
25R804		
25R805		
25R808		
25R813		
25R817		
25R821		
25R824		
25R825		
25R828		
25R833		
25R837		
2000636		
2000640		

## Recommendations for Pump Usage in Harsh Environments

- Use pump with CPC style power cable.
- Use a corrosion preventative electrical grease on all contacts.

## Wiring and Installation Diagrams

**NOTE:** Wire colors provided on these pages refer only to the Graco power cable.

NOTICE
<p>The stirring paddle should rotate clockwise (as viewed from the top) (FIG. 6) when power is applied. Allowing the stirring paddle to rotate counterclockwise damages the pump's internal components.</p> <p>If the stirring paddle is rotating counterclockwise, stop the pump immediately. Check that the wiring is correct and make any necessary changes.</p> <p>If the motor does not run after power is supplied, check the pump wiring.</p>

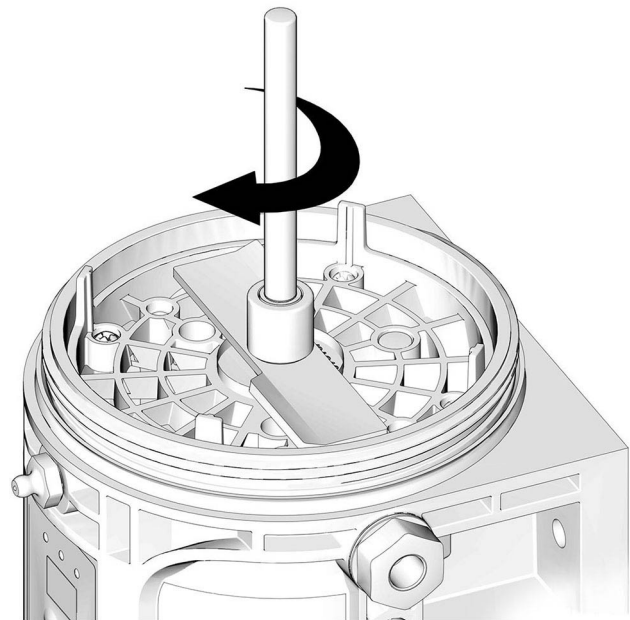

ti37418a

FIG. 6

### Power CPC DC - 5 Wire (Non-Controller)

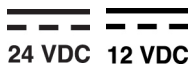

Power Cable CPC DC  
 Part No.: 2003467 - 15 ft (4.5 m), 2003896 - 30 ft (9.1 m)

#### Pin Out

Pin	Pin Name	Wire Color
1	Not Used	Not Used
2	-VDC	Black
3	+VDC	Red
4	Low-Level	White or Yellow
5	Low-Level	Orange
6	Not Used	Not Used
7	Not Used	Green or Blue

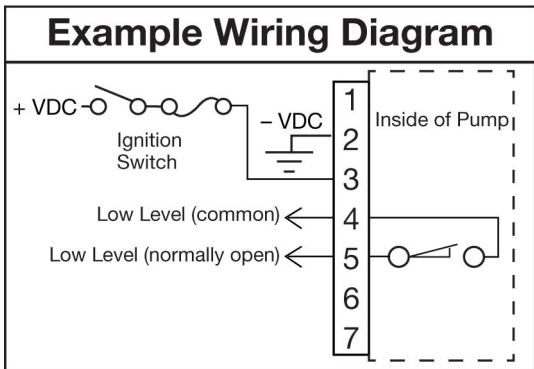
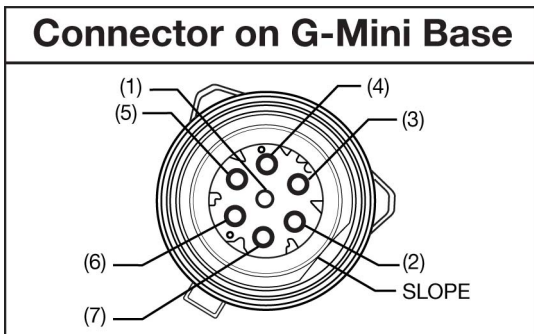
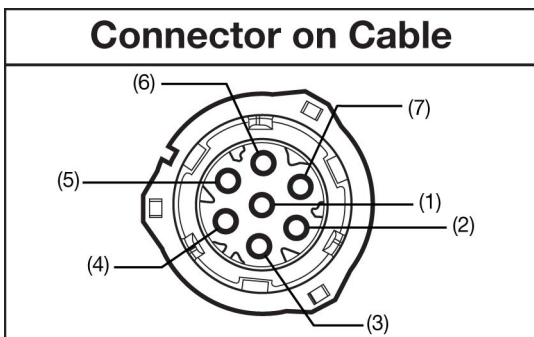

ti37648a

FIG. 7

### Power CPC DC - 5 Wire (Controller)

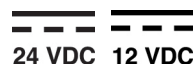

Power Cable CPC DC  
 Part No.: 2003467 - 15 ft (4.5 m), 2003896 - 30 ft (9.1 m)

#### Pin Out

Pin	Pin Name	Wire Color
1	Not Used	Not Used
2	-VDC	Black
3	+VDC	Red
4	LED+	White or Yellow
5	Button	Orange
6	Not Used	Not Used
7	LED-	Green or Blue

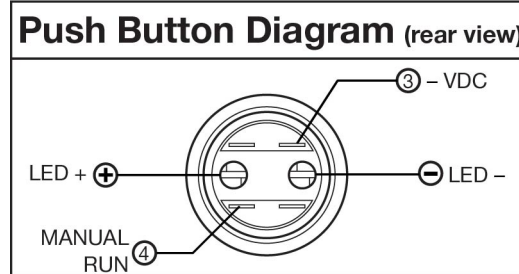
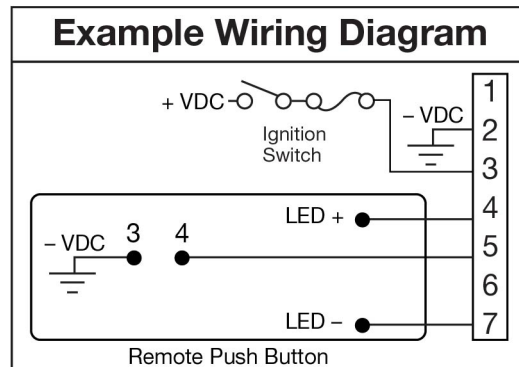
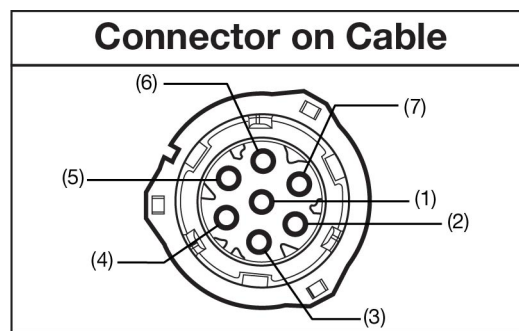

ti00432b

FIG. 8

**Power CPC DC - 2 Wire (Non-Controller) Without Low Level Output**

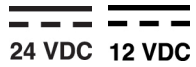

Power Cable CPC DC  
Part No.: 127783 - 15 ft. (4.5 m)

**Pin Out**

Pin	Pin Name	Wire Color
1	Not Used	Not Used
2	-VDC	Black
3	+VDC	White
4	Not Used	Not Used
5	Not Used	Not Used
6	Not Used	Not Used
7	Not Used	Not Used

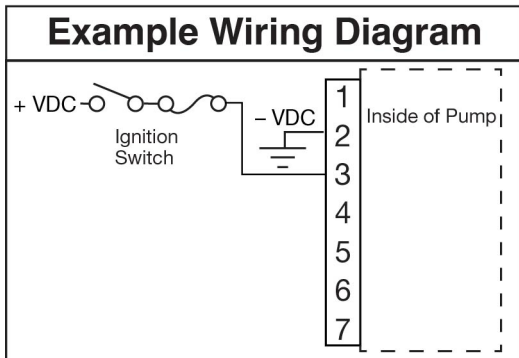
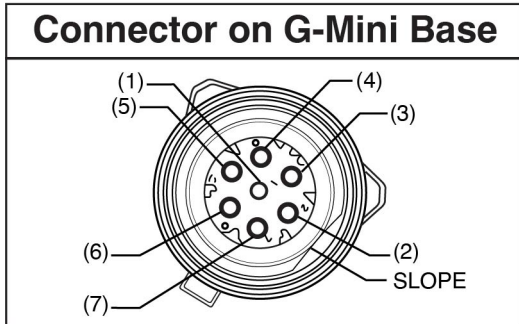
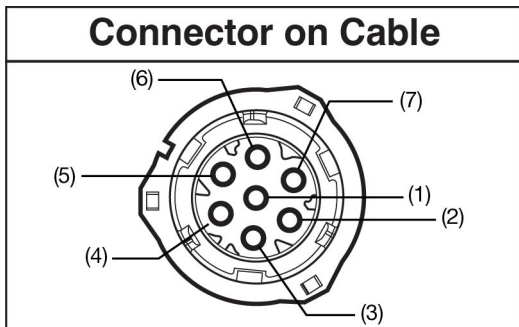

ti38553a

**FIG. 9**

**Power DIN DC - 15 ft Power Cable: Part No, 16U790**

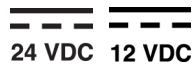

**Pin Out**

Pin	Pin Name	Wire Color
1	-VDC	Black
2	+VDC	White
3	Not Used	Not Used
4	Not Used	Green

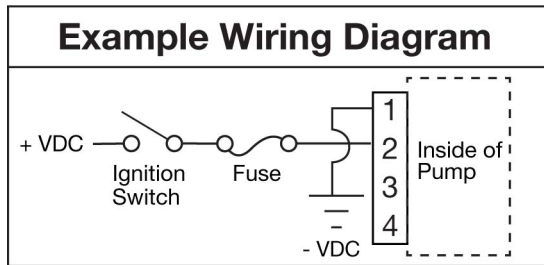
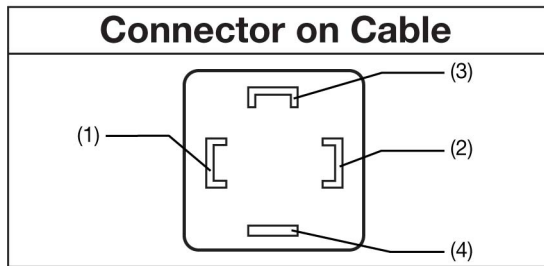
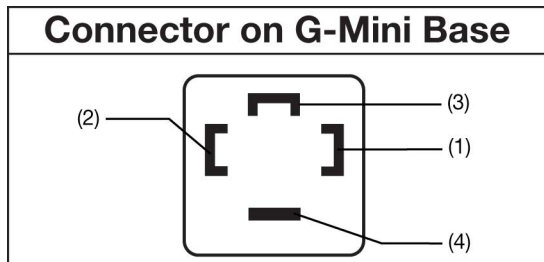

ti01742a

**FIG. 10**

### Power DIN AC

#### Pin Out

Pin	Pin Name
1	Line
2	Neutral
3	Not Used
4	Ground

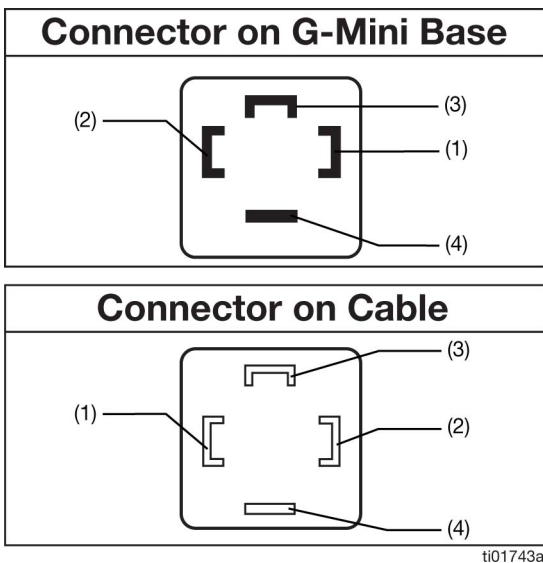

FIG. 11

### Low Level DIN DC

See **Technical Specifications**, page 45 for ratings

#### Pin Out

Pin	Pin Name
1	LL N.O.
2	LL Com
3	Not Used
4	Not Used

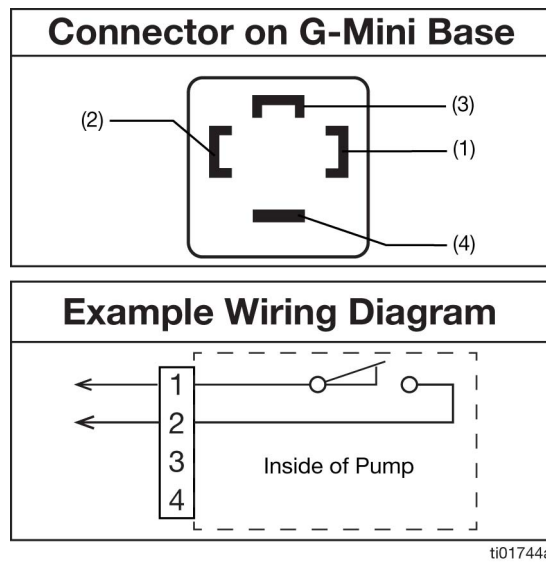

FIG. 12

### Divider Valve Indicator Cycle Inputs (M12)

See **Technical Specifications**, page 45 for ratings.

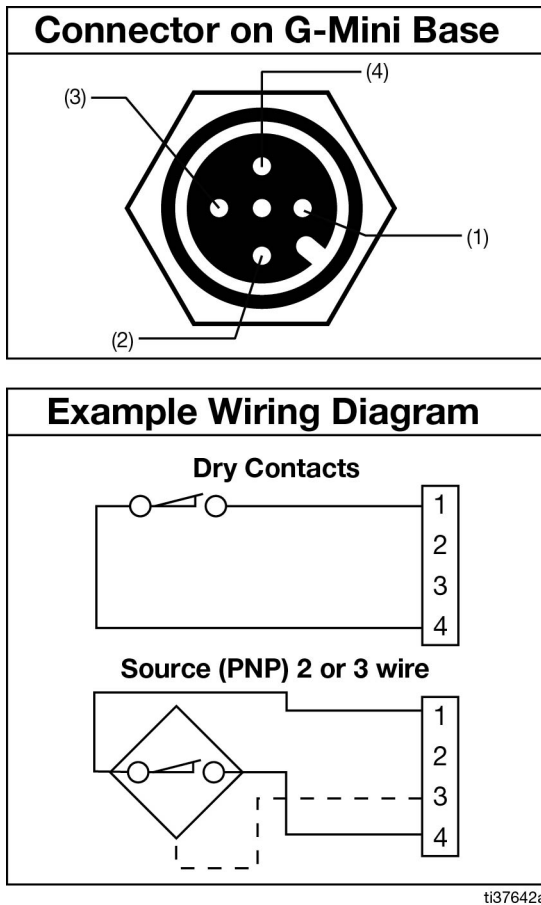

FIG. 13

### Part No. 124333: Cable Pin Out (M12) for 5 m Cable

Wire Colors (FIG. 14)

Item No.	Color
1	Brown
2	White
3	Blue
4	Black

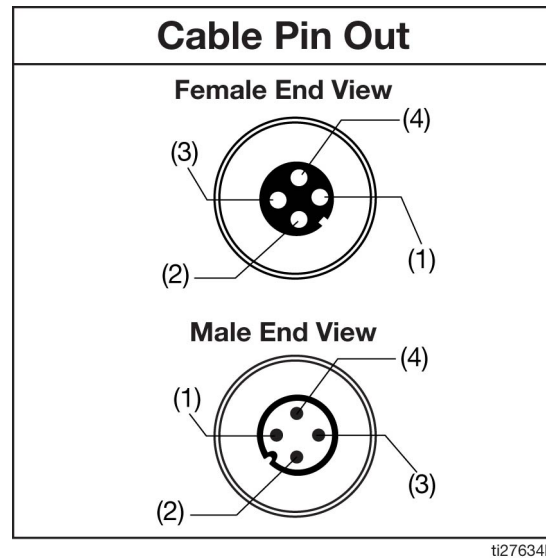

FIG. 14

### Manual Run Button

Part No.	Description	Model
25C981	Manual Run Button, 12V	12 VDC
25C982	Manual Run Button, 24V	24 VDC and VAC



### Manual Run Button DIN DC

See **Technical Specifications**, page 45 for ratings

#### Pin Out

Pin	Pin Name
1	LED-
2	LED +
3	Button
4	Not Used

### Proximity Switch

NOTE: Reference ILE buyer's guide for appropriate PNP or dry contact proximity switches and cables.

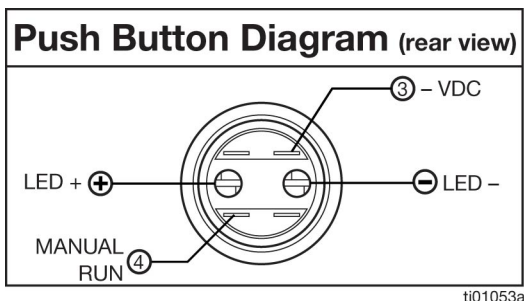

FIG. 15

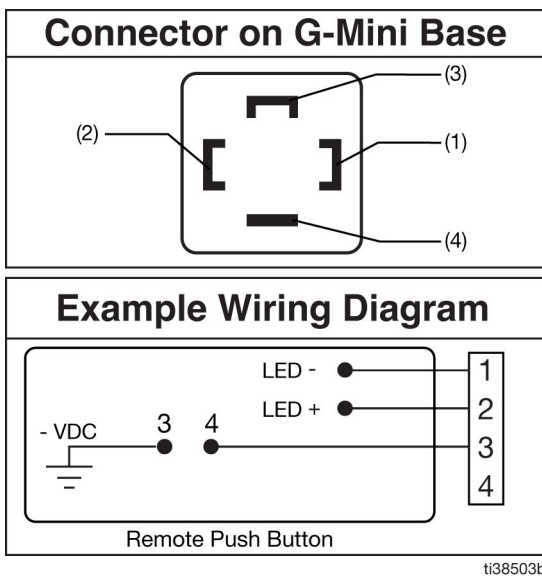

FIG. 16

# Setup

## Pressure Relief Procedure



Follow the Pressure Relief Procedure whenever you see this symbol.

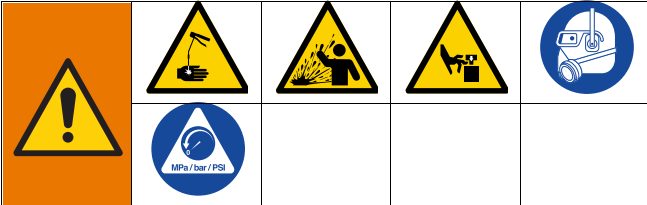

This equipment stays pressurized until pressure is manually relieved. To help prevent serious injury from pressurized fluid, such as skin injection, splashing fluid and moving parts, follow the Pressure Relief Procedure when you stop dispensing and before cleaning, checking, or servicing the equipment.

Disconnect and isolate all power supplies.

Relieve pressure in the system using two wrenches working in opposite directions on the pump element and pump element fitting to slowly loosen fitting only until the fitting is loose and no lubricant or air is leaking from fitting.

**NOTE:** When loosening the pump element fitting, do not loosen the pump element. Loosening the pump element changes the output volume.

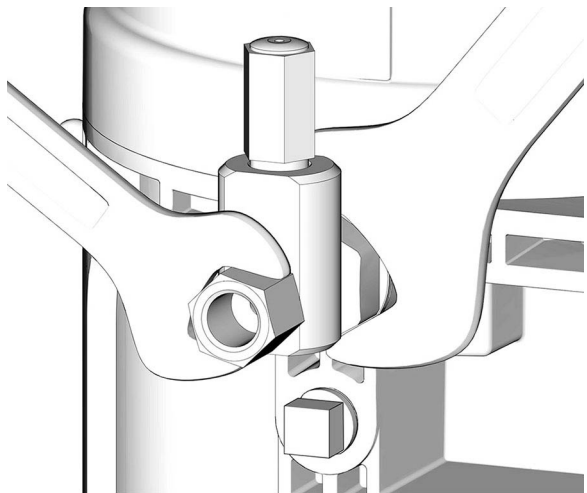
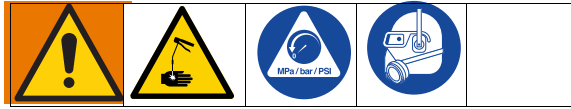

FIG. 17

## Connect to Auxiliary Fittings



### NOTICE

Do not attach unsupported equipment to auxiliary fittings such as fill ports and pump element. Attaching unsupported equipment to these fittings can result in irreparable housing damage.

- Always use two wrenches working in opposite directions when connecting anything to pump element or auxiliary fittings. See FIG. 17 for an example.
- Torque pump element fittings to 50 in-lb (5.6 N•m).
- Torque pump element to 65 in-lb (7.3 N•m) when connecting to the housing.

## Pressure Relief Valves



To prevent over-pressurization, which can result in equipment rupture and serious injury, a pressure relief valve appropriate for the lubrication system must be installed close to each pump outlet to alleviate unintended pressure rises in the system and protect the pump from damage.

- Only use a pressure relief valve that is rated for no more than the working pressure of any component installed in the system.
- Install a pressure relief valve before any auxiliary fitting.

**NOTE:** A pressure relief valve may be purchased from Graco.

## Pressure Relief Valves

Part No.	Description
571028	Kit, Adj. Pressure Relief

## Set Pump Outlet Volume



1. Follow the **Pressure Relief Procedure**, page 18.
2. Use a wrench and turn the pump element counter-clockwise to remove the entire pump element.

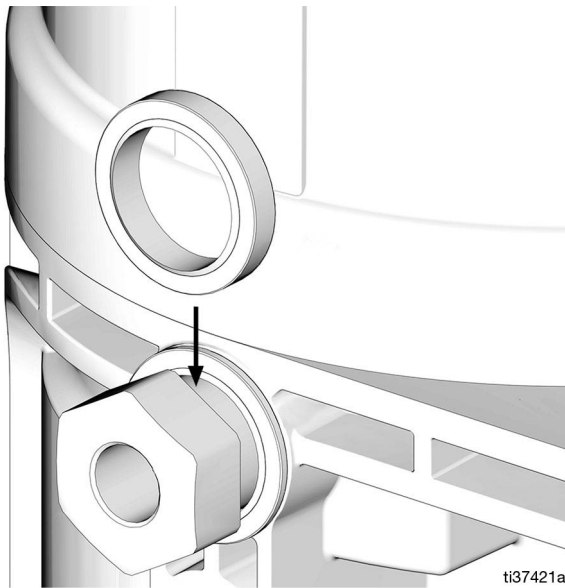

**FIG. 18**

3. Replace the current spacer with the desired spacer.

Spacers	Thickness	Output Volume/Minute	
	mm	Cubic In.	Cubic cm
25N814	1.5	0.183	3.0
18A317	4.6	0.0915	1.5

**NOTE:** A spacer is required for operation and only one Graco spacer can be used at a time. The pumps from the factory have a spacer (25N814) installed on the pump element. **Pump Element Kits** (page 37) come with a spacer. The spacer may be replaced depending upon the required output volume.

4. Re-install the pump element into the pump base, ensuring that the first thread of the element engages correctly.

**NOTE:** It may be necessary to repeat the pump outlet volume setup procedure after the pump is operating to adjust the volume of the dispensed fluids.

5. Use a wrench and tighten the pump element fitting, torque to 50 in-lb (5.6 N•m).

**NOTE:**

- The dispensed volume amount varies upon external conditions, such as lubricant temperature and back pressure from downstream connections.
- Use the volume adjustment process in conjunction with setting the ON time of the pump to control the output volume.
- The volume adjustment process should be used as a starting point for dispensing the desired lubrication volume.

## Fill Reservoir - Grease Dispense Pumps

To ensure optimal performance from the pump:

- Use only NLGI #000 - #2 greases appropriate for the application, automatic dispensing, and the operating temperature of the equipment. Consult with the machine and lubrication manufacturers for details.
- Fill the reservoir using a hand operated pump, pneumatic pump, or electric transfer pump.
- Do not overfill.
- Do not operate the pump without having a reservoir attached.

**NOTICE**

- Always clean the fitting (E) with a clean dry cloth prior to filling the reservoir. Dirt and debris can damage the pump and lubrication system.
- Use care when filling the reservoir using a pneumatic or electric transfer pump to avoid pressurizing and breaking the reservoir.

### Models With a Follower Plate

1. Connect the fill hose to the Zerk Inlet Fill Fitting (E) (FIG. 19).

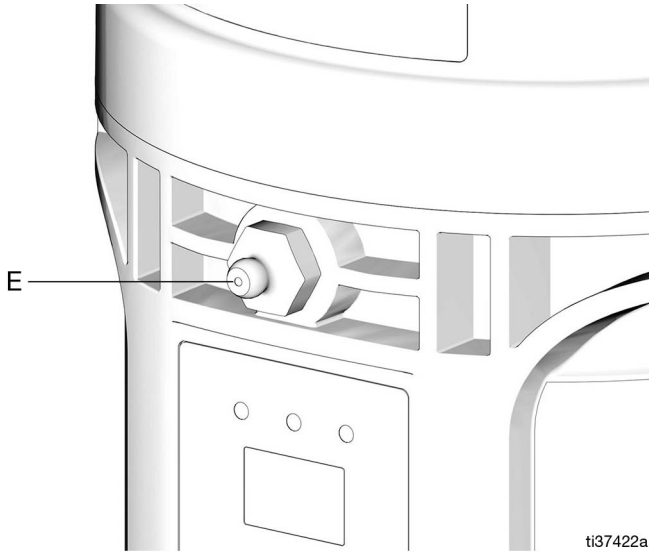

FIG. 19

2. For higher viscosity fluids, start the pump, per the controller instructions, to rotate the stirring paddle (Y) during the fill to prevent air pockets from forming.

For models using an external controller, start the pump operation following the controller instructions.

3. Fill the reservoir with NLGI grease to the MAX line (FIG. 20).

**NOTE:** The venting tube (B) should not be used as an overfill indicator (FIG. 20).

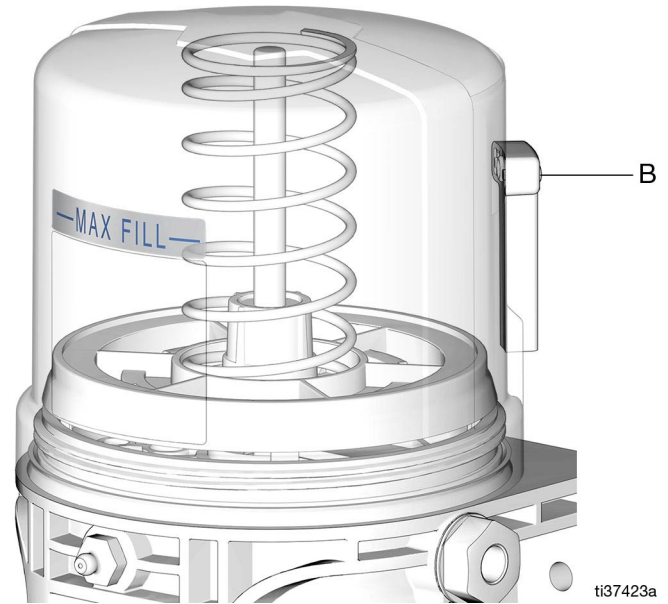

FIG. 20

4. Remove the fill hose.

### Models Without a Follower Plate

1. Connect the fill hose to the Zerk Inlet Fill Fitting (E) (FIG. 21).

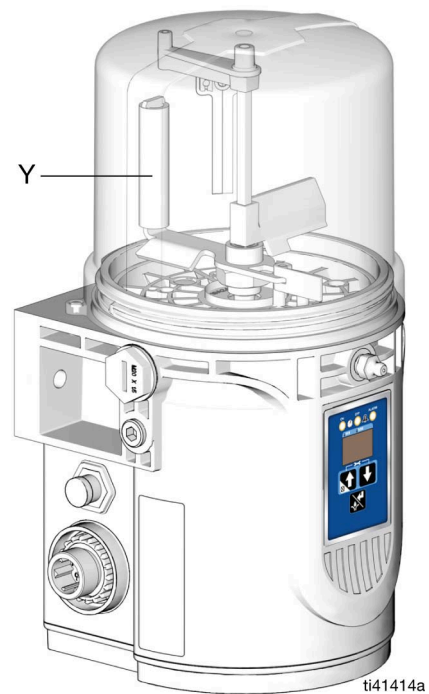

FIG. 21

- For higher viscosity fluids, start the pump, per the controller instructions, to rotate the stirring paddle during the fill to prevent air pockets from forming.

## Change Greases

Always use compatible grease when changing grease.

## Fill Reservoir - Oil Dispense Pumps

- Only use oil appropriate for the application, automatic dispensing, and the operating temperature of the equipment. Consult with machine and lube manufacturer for details.
  - The reservoir can be filled using a hand operated pump, pneumatic pump, or electric transfer pump.
  - Do not overfill (FIG. 22).
  - Do not operate the pump without reservoir attached.
  - Only use oils with viscosity at least 40 cSt.
- Remove fill cap (Z) (FIG. 22).
  - Pour oil into the reservoir to the max fill line (FIG. 22).
  - Reinstall fill cap (Z). Securely hand tighten the cap.

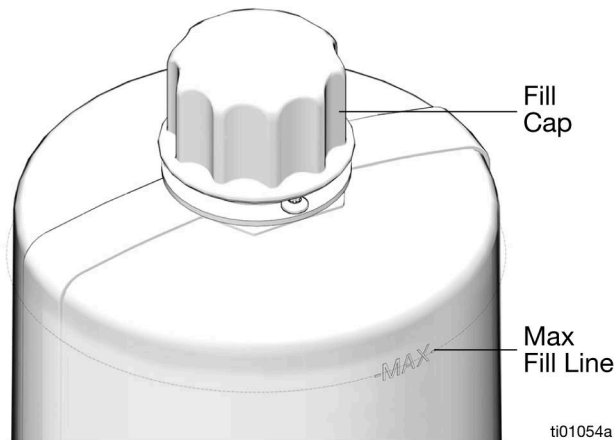

FIG. 22

## Prime the Pump

It is not necessary to prime the pump every time the pump is filled. The pump only requires priming the first time it is used, or if it is allowed to run dry.

- Loosen the pump element fitting (FIG. 23).

**NOTE:** When loosening the pump element fitting, do not loosen the pump element. Loosening the pump element changes the output volume and causes leakage.

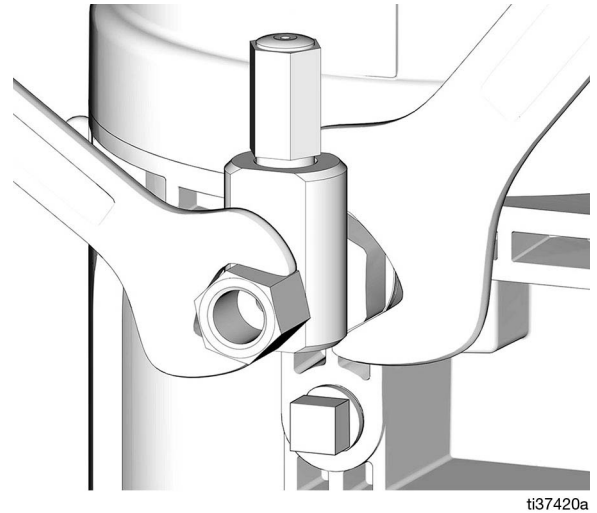

FIG. 23

- Only run the pump until air is no longer dispensed with the lubricant out of element fitting (FIG. 24).

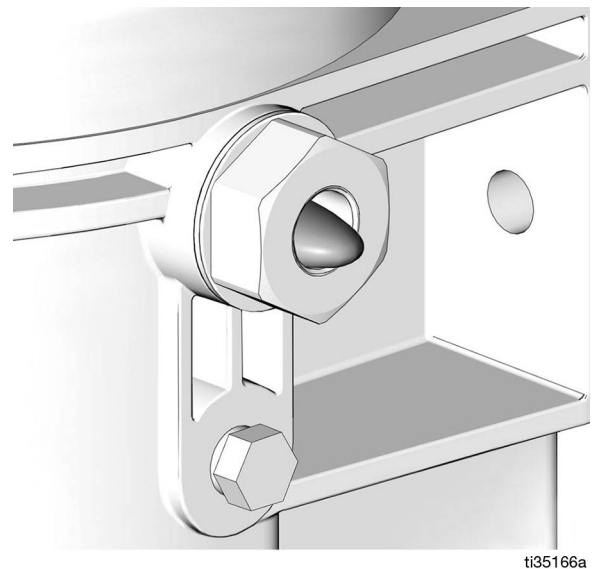
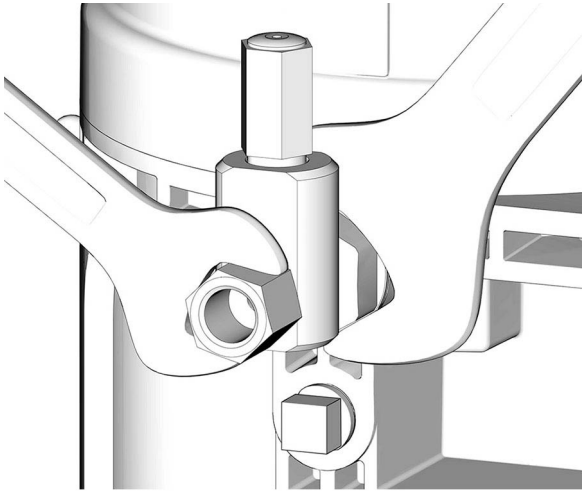

FIG. 24

Setup

3. Tighten the pump element fitting using two wrenches working in opposite directions (FIG. 25).



ti37420a

**FIG. 25**

---

# Operation

## Non Controller Operation

The pump can be controlled using an external, user supplied, controller.

**NOTE:**

- When using an external controller, the Pump ON (Run) Time should be set for no longer than 30 minutes.
- In most cases, the Pump OFF (Rest) Time should be twice as long as Pump ON (Run) time. If alternative ON / OFF times are required, contact Graco Customer Service for assistance.

### Low-Level Output Option

**Models 25R800, 25R802, 25R807, 25R809, 25R811, 25R812, 25R831, and 25R832**

Pumps without controllers include a Low-Level Output Option. The low-level signal is monitored across PINS 4 and 5. For the locations and wiring information for PINS 4 and 5, see the **Power CPC DC - 5 Wire (Non-Controller)**, page 13.

**Model 2000643, 2000645, 2000648, 2000650, 2000634, 2000635, 2000638, 2000639, 25R820, 25R822, 25R827, 25R829, 25R815, 25R816, 25R835, and 25R836**

See the **Low Level DIN DC**, page 15.

### Typical Low-Level Output Response with Low-Level Fluid

**Models with a follower plate**



FIG. 26

**Models without a follower plate**

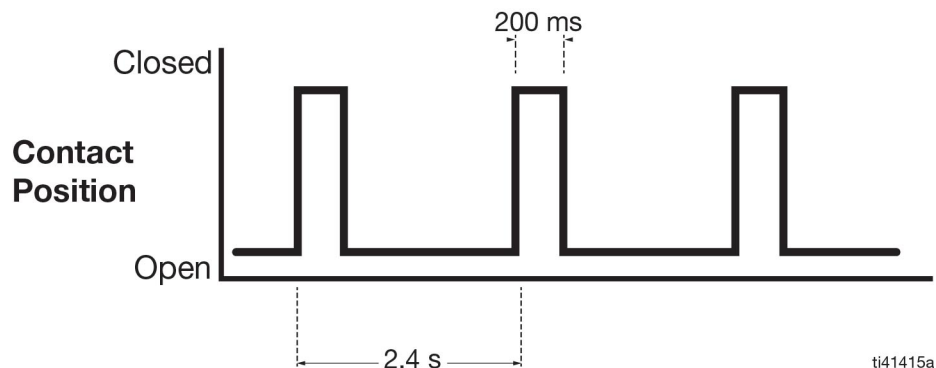

ti41415a

FIG. 27

**Typical Low Level Output Response with Low Level Fluid in Oil Models**

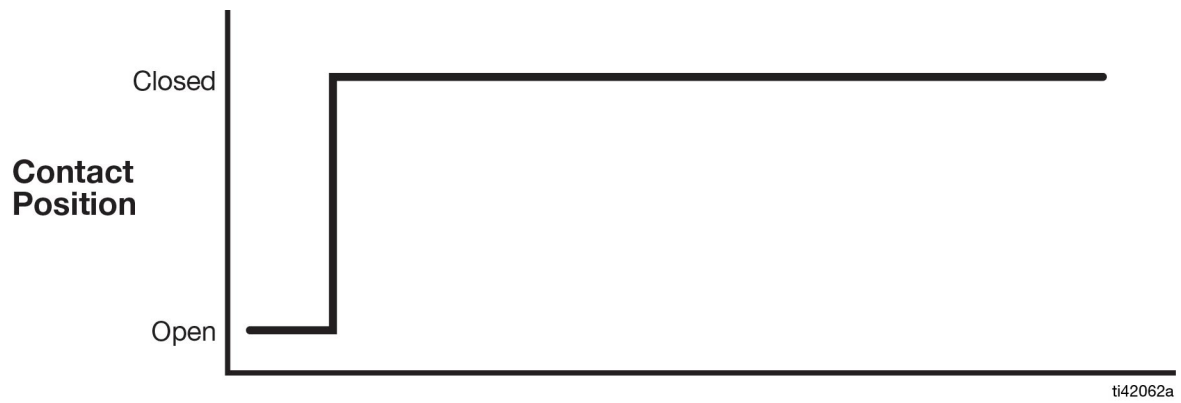

**FIG. 28**

---



# Controller Operation

## Control Panel Overview (FIG. 29)

### ON TIME

- In SETUP MODE, the LED illuminates when ON TIME duration or cycles are set up.
- A dot illuminates under MM on the display.
- The ON TIME range is 1 to 30 minutes, or 1 to 99 cycles.
- In RUN MODE, the LEC illuminates during the ON TIME sequence.

### OFF TIME

- In SETUP MODE, the LED illuminates when OFF TIME duration set up.
- A dot illuminates under HH on the display.
- The OFF TIME range is 15/30/45 min or 1 to 99 hours.
- The LED illuminates when OFF TIME sequence is running.

### DISPLAY

- Upon entering SETUP MODE, the first digit in the display begins to blink.
- In RUN MODE, the programmed ON TIME, CYCLES or OFF TIME displays and counts down to zero.

### ALARM

The LED illuminates when an alert/alarm event occurs. Most alerts/alarms occur during ON TIME MODE. However, if a Low-Level alert triggers near the end of an ON TIME cycle, the alert will display while the controller is in OFF TIME MODE. A software error occurring when the controller is operating in the OFF TIME MODE will also activate the alarm LED.

### UP and DOWN ARROWS

- Hold both the UP and DOWN arrow buttons together for 3 seconds to enter SETUP MODES.
- In SETUP MODE, the UP and DOWN arrows increase or decrease time and cycle setting values shown on the display.
- In RUN TIME MODE, pressing the UP arrow/CANCEL button terminates the lubrication period.

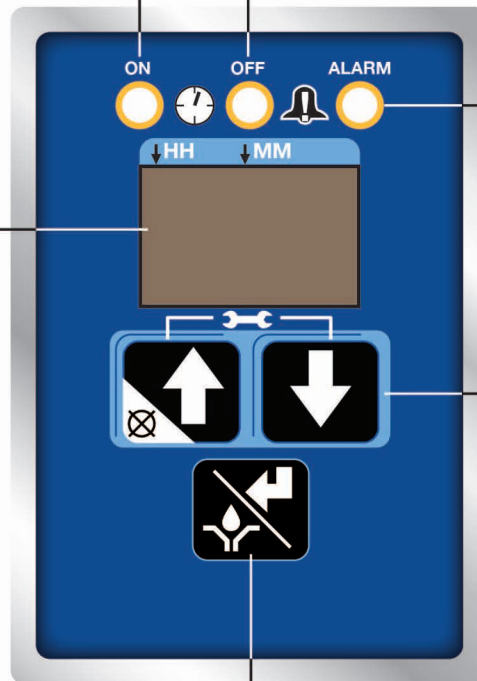

### MANUAL RUN/ENTER

- In SETUP MODE, press this button to save the entry, move the cursor in the display one field to the right or to the next setup step.
- In RUN MODE, press this button to start a manual run cycle.



ti35513a

FIG. 29

The controller operates in two modes; RUN MODE and SETUP MODE. Each mode has multiple functions.

## RUN MODE

RUN MODE performs two functions while monitoring Alert/Alarm conditions: ON TIME and OFF TIME.

- In ON TIME the motor is running and the lubrication is delivered. ON TIME can be configured to be active for a period of time in minutes or a period of lube cycles (cycle or proximity switch is required).  ti01062a
- In OFF TIME the motor is not running. This is a period where no lubrication is delivered. OFF TIME can be configured for 15 / 30 / 45 min. or 1 to 99 hours.  ti01063a

By default, units with controllers are set to operate with an ON TIME period of five (5) minutes and an OFF TIME period of 1 hour.

Once an ON TIME lubrication period begins, it can be terminated by pressing the UP arrow/CANCEL button.



While in RUN MODE the controller monitors Alert/Alarm conditions. See **Alert and Alarm Scenarios**, page 33 for full descriptions.

## SETUP MODE

Press both the UP and DOWN arrow buttons together for 3 seconds to enter SETUP MODE.

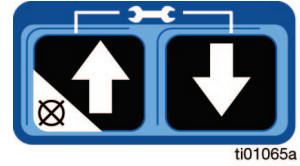

The first digit on the display begins to blink. This indicates SETUP MODE. After entering SETUP MODE, if no activity is detected after 60 seconds, a timeout occurs and the controller resumes in RUN MODE.

### ON TIME Configuration (Minutes)

The first configuration in SETUP MODE is to program ON TIME.

Notice the following on the controller:

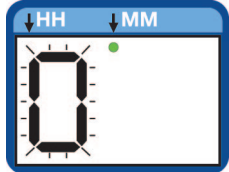
- The LED next to the Clock in the ON field illuminates.  ti01062a
- The first digit on the display begins to blink.  ti01066a
- A dot on the display under the MM illuminates.

This confirms the controller is ready for the first digit to be configured for ON TIME in Minutes (MM).

**NOTE:** The ON TIME can be configured between 1 to 30 minutes.

- Press the UP or DOWN arrows to select the first digit.

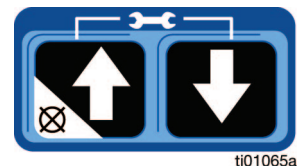

- Press the ENTER button to save the selection.



After the ENTER button is pressed, the second digit begins to blink. The ON LED and MM dot remains lighted.

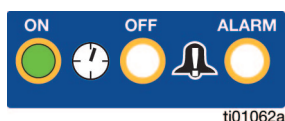

This confirms the second digit for ON TIME is being configured in Minutes (MM).

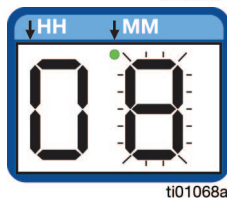

3. Press the UP or DOWN arrows to select the second digit.

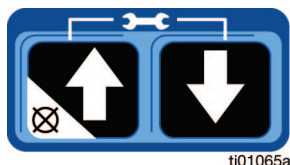

4. Press the ENTER button to save the selection.



The controller automatically switches to OFF TIME configuration.

### ON TIME Configuration (Cycles)

**NOTE:** The proximity switch accessory must be installed and Cycle Count enabled in Advanced Programming (page 28) before the number of cycles can be configured in SETUP MODE.

Notice the following on the controller:

- The LED next to the Clock in the ON field illuminates
- The display reads "CY" to identify that the ON TIME is configured for Cycles Counts.

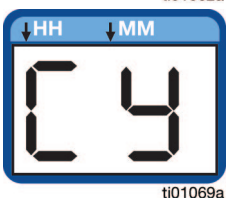
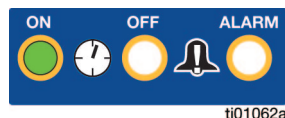

**NOTE:** The number of cycles counts can range from 1 to 99.

1. Press the ENTER button to advance the display.



The first digit on the display begins to blink. This confirms the controller is ready for the cycle count to be configured.

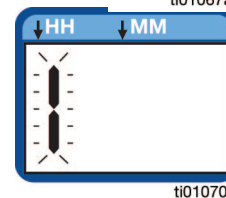

2. Press the UP or DOWN arrows to select the first digit.

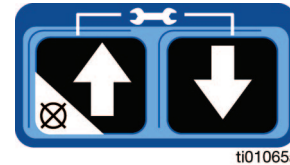

3. Press the ENTER button to save the selection.



After the ENTER button is pressed, the second digit begins to blink. The ON LED remains lighted.

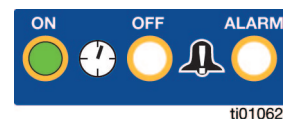

This confirms the second digit for ON TIME is being configured in Minutes (MM).



4. Press the UP or DOWN arrows to select the second digit.

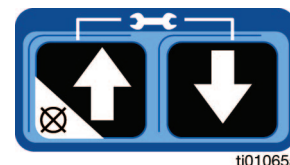

5. Press the ENTER button to save the selection.



The controller automatically switches to OFF TIME configuration.

## OFF TIME Configuration (Min./Hrs)

Notice the following on the controller:

- The LED next to the Clock in the OFF field is lighted.
- The first digit on the display begins to blink.
- A dot on the display under the HH illuminates.

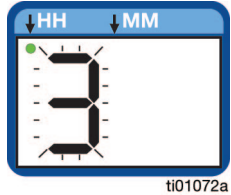
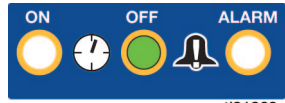

This confirms the controller is ready for the first digit to be configured for OFF TIME in Hours (HH).

**NOTE:** The OFF TIME must be configured between 15 min and 99 hours.

1. Press the UP or Down arrows to select the first digit.
2. Press the ENTER button to save the selection.

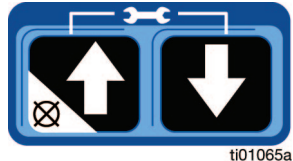

After the ENTER button is pressed, the second digit begins to blink. The OFF LED and HH dot remain lighted.

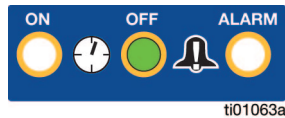

This confirms the second digit for OFF TIME is being configured in Hours (HH).

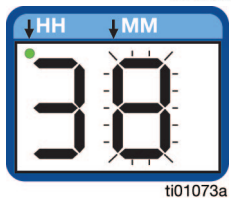

3. Press the UP or DOWN arrows to select the second digit.
4. Press the ENTER button to save the selection.

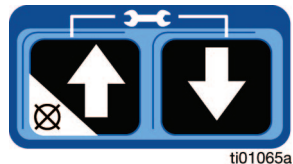

The controller automatically switches to RUN MODE.

## ADVANCED PROGRAMMING

The Seven Advanced Programming Menu Descriptions are:

- A1 - PIN Entry Enable/Setting Up the PIN Code, page 29
- A2 - Prelube and Delay, page 31
- A3 - Low-Level Alert Duration, page 31
- A4 - Missed Cycle Threshold, page 31
- A5 - Low-Level Power Cycle Retry, page 31
- A6 - Low-Level Alert Enable, page 31
- A7 - Cycle Count Enable, page 31

To access ADVANCED PROGRAMMING:

1. Press both the UP and DOWN arrow buttons for 3 seconds to enter SETUP MODE.

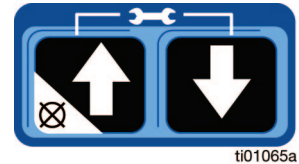

2. In SETUP MODE, press and hold the UP arrow for 10 seconds.



The display reads A1. This confirms the controller is in the ADVANCED PROGRAMMING settings.

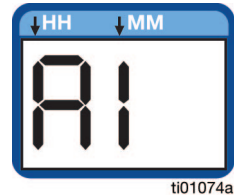

After entering ADVANCED PROGRAMMING, if no activity is detected for 60 seconds, a timeout occurs and the controller resumes RUN MODE.

Press the ENTER button to advance to the configurable portion of the specific settings.



1. Press the UP or DOWN arrows to configure the selection.

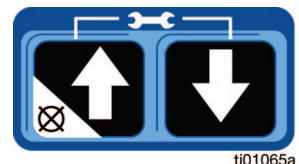

For ON or OFF selection:

- ON: UP arrow
- OFF: DOWN arrow

2. After completing configuration, press the ENTER button to save and proceed to the next ADVANCED PROGRAMMING settings.



ti01067a

After all of the ADVANCED PROGRAMMING settings are configured, press the ENTER button to return the controller to RUN MODE.

## Advanced Programming Menu Descriptions

### A1 – PIN Entry Enable/Setting Up the PIN Code

A PIN Code provides additional controller security by requiring a PIN Code be entered before gaining access to SETUP MODE.

**NOTE:** The PIN Code can be configured to be any number between (and including) 00 and 99.

#### To set up the PIN Code:

1. Follow Steps 1 and 2 of **ADVANCED PROGRAMMING**, (page 28).
2. When A1 appears on the display, press the ENTER button. Either On (PIN Code ON) or OF (PIN Code OFF) displays.
  - On (ON) - Select On to configure the controller to require a PIN Code be entered prior to accessing SET UP Mode.



ti01067a



ti01075a

- OF (OFF) - Select OF to configure the controller to not require a PIN code. Press the ENTER button again to set the OF (OFF) option.

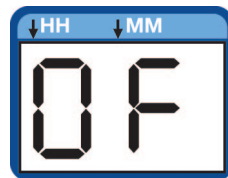

ti01076a

3. The first digit on the display begins to blink. This confirms the controller is ready to select the first number of the PIN Code.

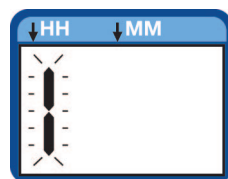

ti01070a

4. Press the UP or Down arrows to select the first digit.

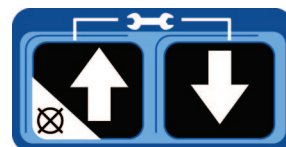

ti01065a

5. Press the ENTER button to save the selection.



ti01067a

After the ENTER button is pressed, the second digit begins to blink.

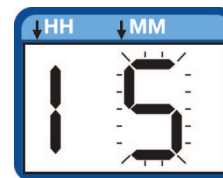

ti01071a

This confirms the second digit for the PIN Code is ready to be configured.

6. Press the UP or Down arrows to select the second digit.

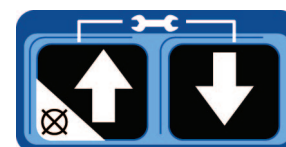

ti01065a

7. Press the ENTER button to save the selection.



ti01067a

8. The controller automatically advances to the A2 screen.

### Entering a PIN Code in the Controller

After the controller is configured for PIN entry, to access SETUP MODE:

1. Follow Steps 1 and 2 of **ADVANCED PROGRAMMING**, (page 28).

2. Pn appears on the display.

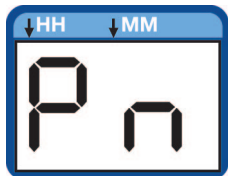

3. Press the ENTER button to advance the display.



4. The first digit on the display begins to blink. This confirms the controller is ready for the first number of the PIN Code to be entered.

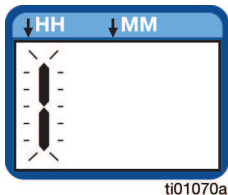

5. Press the UP or Down arrows until the first digit of the PIN Code displays.

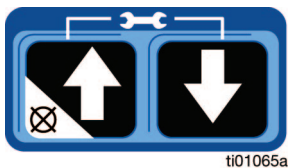

6. Press the ENTER button to save the entry.



7. After pressing the ENTER button, the second digit begins to blink. This confirms the controller is ready for the second number of the PIN Code to be entered.



8. Press the UP or Down arrows until the second digit of the PIN Code displays.

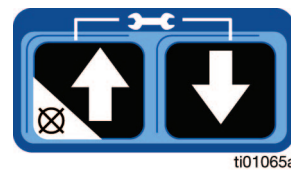

9. Press the ENTER button to save the entry.



10. The ON TIME configuration screen displays. See **SETUP MODE, ON TIME Configuration (Minutes)**, page 26 for additional information.

## A2 – Prelube and Delay

The Prelube Delay option configures the controller to set the amount of time before the Prelube cycle begins. The duration of time begins after power has been restored to the controller. This value can range from 0 to 60 minutes (default: 0).

The Prelube function determines operation of the pump when power is applied. It can be set to ON or OFF.

- OF (OFF) (default) – The unit resumes at the point in the lubrication cycle it was at when power was disengaged.
- On (ON) – The unit begins a pump cycle once power is restored.

When On is selected and the Enter button is pressed, the controller is ready to configure a Prelube delay. See **ADVANCED PROGRAMMING** instructions, page 28.

## A3 – Low-Level Alert Duration

The Low-Level Alert Time configures the controller to set the duration of time that a Low-Level Alert exists with the pump running before escalating to an Alarm.

The Low-Level Alert Time can range from 1 to 5 minutes (default: 3). To configure the Low-Level Alert Time, see **ADVANCED PROGRAMMING** instructions, page 28.

## A4 – Missed Cycle Threshold

While operating in Cycle Mode, the Cycle Alarm Threshold configures the controller to set the number of consecutively missed Cycles allowed before activating an alarm.

The Cycle Alarm Threshold can range from 0-99 cycles (default:0). To configure the Cycle Alarm Threshold, see **ADVANCED PROGRAMMING** instructions, page 28.

## A5 – Low-Level Power Cycle Retry

When set to ON, the Low-Level Auto Clear allows the controller to attempt to automatically clear a Low-Level Alarm during the power cycle. This is only used when a controller has the power removed while in a Low-Level Alarm state.

The Low-Level Auto Clear is an OF (OFF) or On (ON) selection.

- OF (OFF) (default) – Upon power cycle, the controller will remain in its current Low-Level Alarm state.
- On (ON) – Upon power cycle, the controller will begin a lubrication cycle to determine if a Low-Level condition still exists.

See **ADVANCED PROGRAMMING** instructions, page 28.

## A6 – Low-Level Alert Enable

The Low-Level Warning Enable configures the controller to trigger a Low-Level Alert prior to the escalation of an Alarm.

The Low-Level Warning Enable is an OF (OFF) or On (ON) selection.

- OF (OFF) (default) – Low-Level conditions are immediately escalated to Alarm status.
- On (ON) – Low-Level conditions are first reported as an Alert for the duration of setting A3, at which point they escalate to an Alarm.

See **ADVANCED PROGRAMMING** instructions, page 28.

## A7 – Cycle Count Enable

The Cycle Lubrication Enable configures the controller to use Cycle Counts to monitor the duration of a lubrication period and enables the M12 Cycle Indicator Connector.

The Cycle Lubrication Enable is an OF (OFF) or On (ON) selection.

- OF (OFF) (default) – The lubrication period will be monitored in minutes.
- On (ON) – The lubrication period is monitored in cycles. This requires the addition of a proximity switch. The number of cycles must also be configured in SET UP mode (page 26).

See **ADVANCED PROGRAMMING** instructions, page 28.

## Alerts and Alarms

The controller monitors and displays two types of events: Alerts and Alarms.

### Alerts

Alerts do not stop the lubrication cycle. These events are automatically cleared based upon the alert received.

An amber LED illuminates under ALARM on the display when an Alert occurs. See **Alert and Alarm Scenarios** on page 33 for a description of Alerts that could occur.

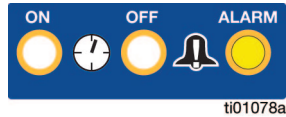

### Alarms

Alarms stop the lubrication cycle. Alarms can trigger immediately, or can be the result of an escalated Alert. Alarms must be cleared immediately.

A red LED illuminates under ALARM on the display when an Alarm occurs. See the **Alert and Alarm Scenarios** table on page 33 for a description of Alarms that could occur.

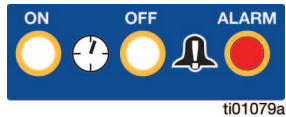







When an Alarm is triggered, any active lubrication cycle will be terminated. The display begins to count up to identify how long the Alarm condition has been present. The counter begins in minutes, then changes to hours, with a limit of 99 hours.

See **ADVANCED PROGRAMMING**, page 28 for additional information about configuring the controller for Alerts and Alarms.

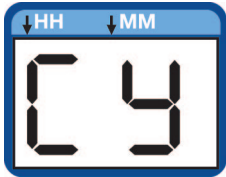

## Alert and Alarm Scenarios

The following pages describe the most likely alerts and alarms:

Alarm Type	Display	What it Indicates	Solution
<b>Low-Level</b>	 <p>ti01080a</p>	There is a low-level of lubricant in the reservoir	<p>Add lubricant to reservoir.</p> <p>An alert will auto-clear.</p> <p>Reset the alarm by pressing and holding the Cancel Button for 4 seconds.</p>  <p>ti01064a</p>
<b>Cycle</b>	 <p>ti01069a</p>	The cycle was not completed in 4 minutes.	<p>Check for a plugged or broken line, or other component failure such as a divider valve.</p> <p>An alert will auto-clear.</p> <p>Reset the alarm by pressing and holding the Cancel Button for 4 seconds.</p>  <p>ti01064a</p>
<b>Over Current</b>	 <p>ti01081a</p>	<p>The measured motor current is above the maximum operating level.</p> <p>The motor turns off and a new lube cycle is not allowed to be initiated.</p>	<p>Check to make sure that the system is operating correctly. A blocked line could create excessive motor current.</p> <p>Examine the pump to verify it is rotating properly.</p> <p>Reset the alarm by pressing and holding the Cancel Button for 4 seconds.</p>  <p>ti01064a</p>
<b>System Fault</b>	 <p>ti01082a</p>	<p>An internal fault has occurred.</p> <p>The controller may not be recoverable from this state.</p>	<p>Attempt a power cycle of the device.</p> <p>If the alarm does not clear, contact Graco Customer Service.</p>

# Maintenance

<b>Frequency</b>	<b>Component</b>	<b>Required Maintenance</b>
Daily and at Refill	Fill Fittings	Keep all of the fittings clean using a clean dry cloth. Dirt and/or debris can damage the pump and/or the lubrication system.
Daily	Pump Unit and Reservoir	Keep pump unit and reservoir clean using a clean dry cloth.
Monthly	External Wiring Harness	Verify external harnesses are secure.

# Recycling and Disposal

## End of Product Life

At the end of the product's useful life, dismantle and recycle it in a responsible manner.

- Perform the **Pressure Relief Procedure**, page 18.
- Drain and dispose of fluids according to applicable regulations. Refer to the material manufacturer's Safety Data Sheet.
- Remove motors, circuit boards, and other electronic components. Recycle according to applicable regulations.
- Do not dispose of electronic components with household or commercial waste. 
- Deliver remaining product to a recycling facility.

# Troubleshooting

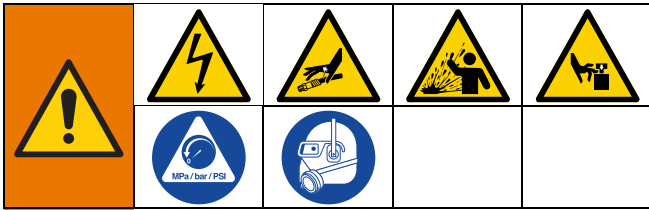



Follow **Pressure Relief Procedure**, page 18, before checking or repairing.

**NOTE:** Check all possible problems and causes before disassembling the equipment.

Problem	Cause	Solution
Unit does not power on (DC models only),	Incorrect/loose wiring	Refer to <b>Typical Installation</b> instructions, page 8.
	Tripped external fuse due to internal component failure.	Contact Graco Customer Service.
	Tripped external fuse from using grease with an inadequate temperature rating in a cold environment.	Replace lubricant with a lubricant rated for environmental conditions and application. Replace fuse.
Unit does not power on (AC models only).	Tripped internal power supply fuse due to power supply failure.	Contact Graco Customer Service.
Lubricant leaks past the seal located on the bottom of the reservoir.	Seal was not installed correctly.	Replace seal.
	Reservoir is being pressurized during filling.	Ensure that the vent tube is not plugged.  If the problem persists, contact Graco Customer Service or your local Graco distributor for assistance.
The external controller is functioning, but the unit is not pumping during the ON cycle.	Motor failure.	Replace the motor.
The follower plate is not moving downward.	Air is trapped in the reservoir between the follower plate and the lubricant.	Add grease following the <b>Fill Reservoir - Grease Dispense Pumps</b> instructions, page 19.  Purge any air from the reservoir.
After wiring and installing the equipment, the pump is not working.	The pump is wired incorrectly.	Rewire the pump following <b>Wiring and Installation Diagrams</b> , page 12.

# Repair

				
All electrical wiring must be done by a qualified electrician and comply with all local codes and regulations.				

## Reservoir Kits

Kit No.	Description
26C943	Kit Replacement, Reservoir, 1 L
26C945	Kit Replacement, Reservoir, 0.5 L
26C944	Kit Replacement, Reservoir, Follower Plate, 1 L
26C946	Kit Replacement, Reservoir, Follower Plate, 0.5 L
26D679	Kit Replacement, Reservoir, 2 L
2003011	Kit Replacement, Reservoir, Fill Lid, 1 L
2003012	Kit Replacement, Reservoir, Fill Lid, 2 L

## Pump Element Kits

Kit No.	Description
26C947	Standard G-MINI Pump Element; Output: 3 cc/min.
26C948	Alternative G-MINI Pump Element; Output: 1.5 cc/min.

# Parts

## Grease Model 1 L and 0.5 L

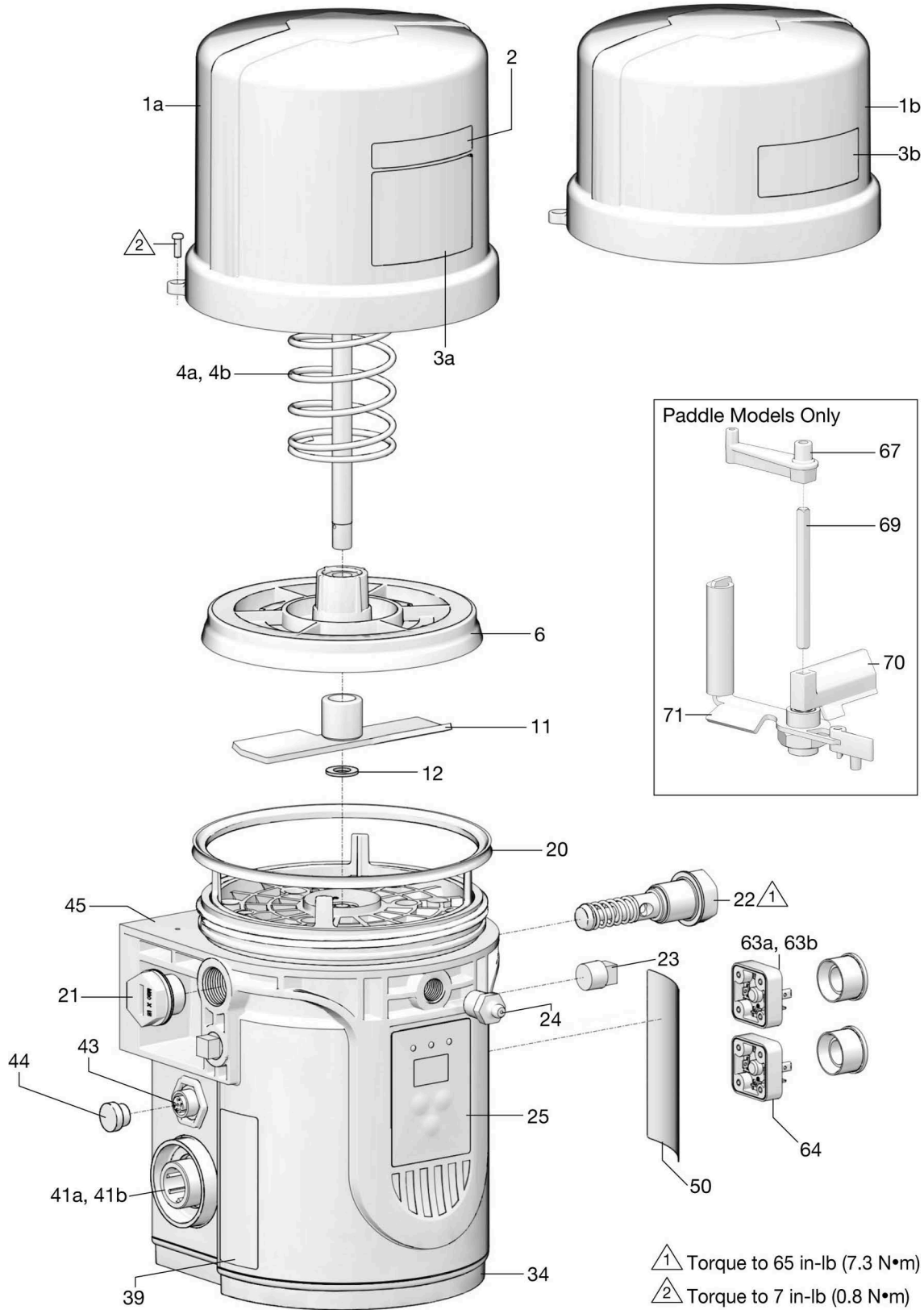

# Grease Model 2 L

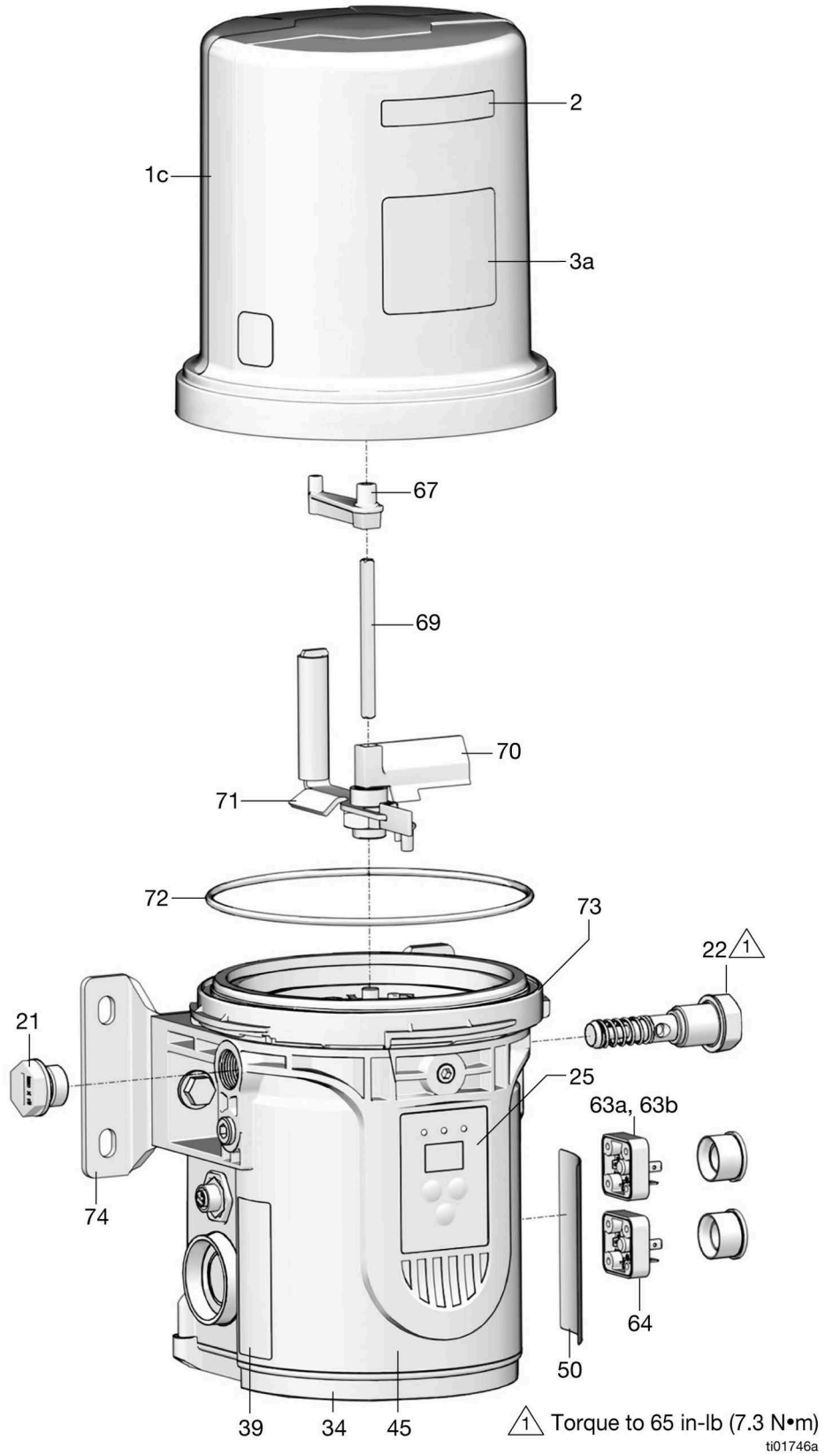

# Oil Model 1 L

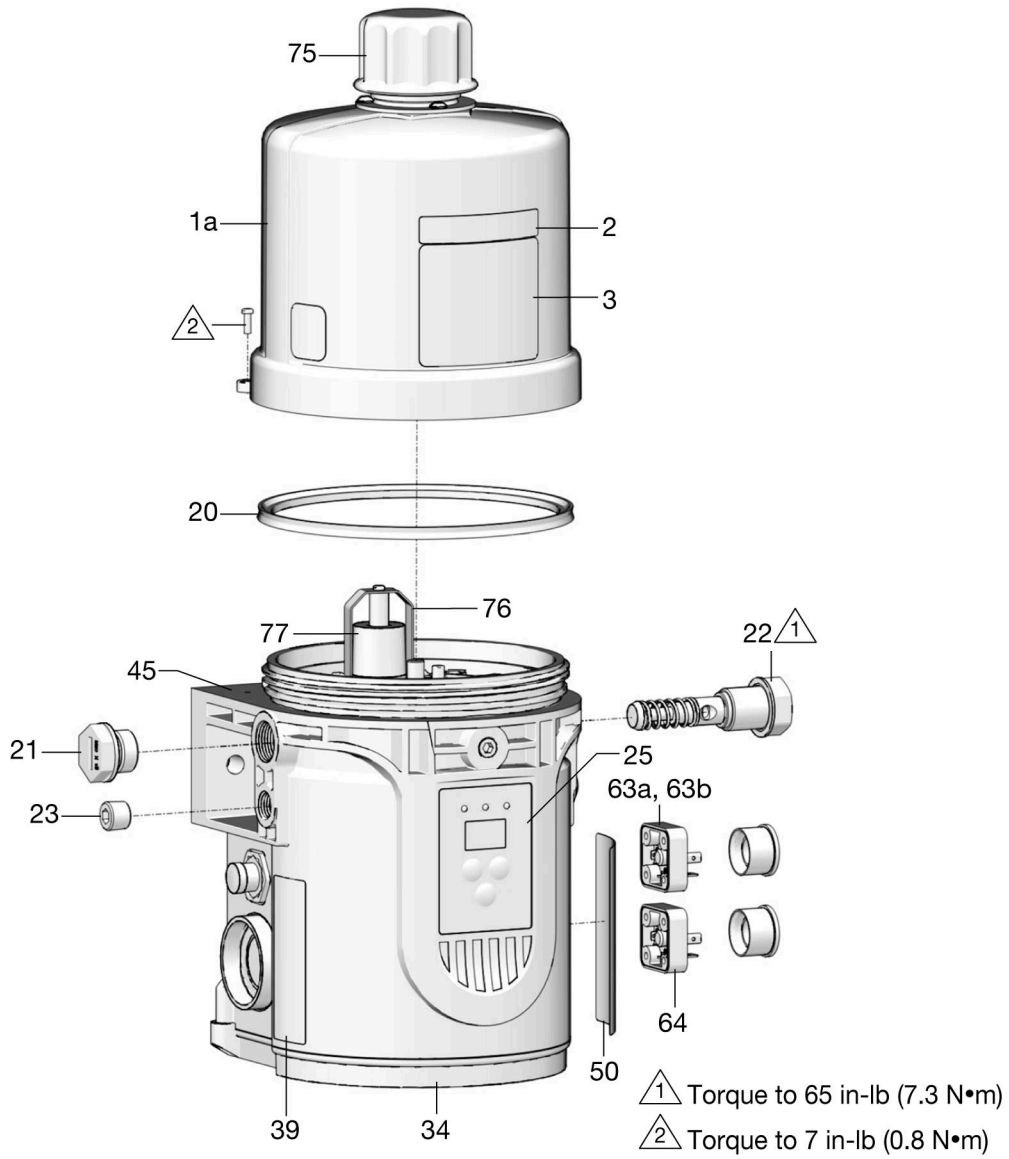

ti01745a



# Oil Model 2 L

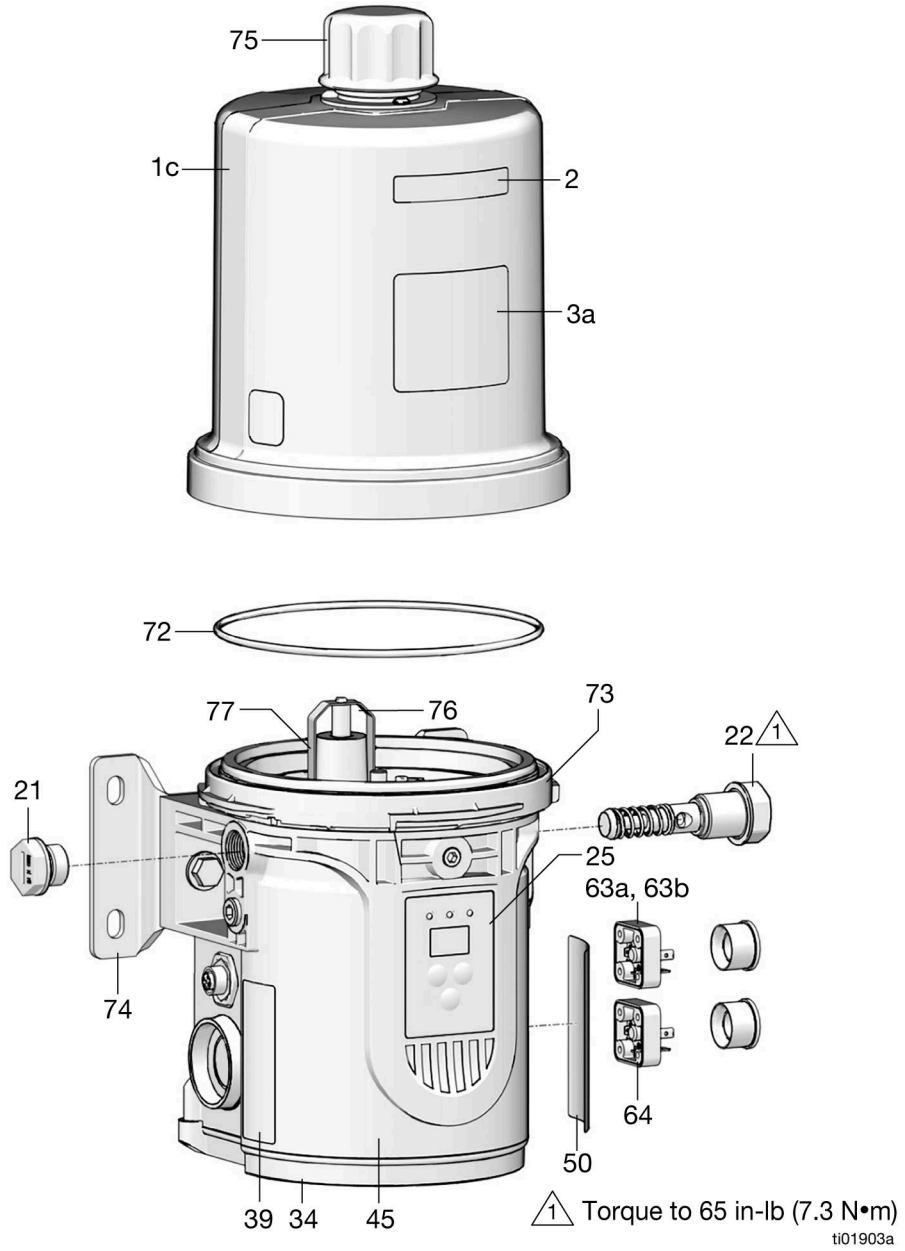

**Part No./Description**

Ref.	Part	Description	Qty.
1a		Reservoir, 1.0 Liter, included in kits 26C943, 26C944 (1 L Models)	1
1b		Reservoir, 0.5 Liter, included in kits 26C945, 26C946 (0.5 L Models)	1
1c		Reservoir, 2.0 Liter, included in kits 26D679 (2 L Models)	1
2		Label, max fill, included in kits 26C943, 26C944, 26D679 (1 L and 2 L Models)	1
3a		Label, branding, 1 L, included in kits 26C943, 26C944, 26D679 (1 L and 2 L Models)	1
3b		Label, branding, 0.5 Liter, included in kits 26C945, 26C946 (0.5 L Models)	1
4a		Spring, compr., 1.0 Liter Reservoir, included in kit 26C944 (1 L Models)	1
4b		Spring, compr., 0.5 Liter Reservoir, included in kit 26C946 (0.5 L Models)	1
6		Plate, follow, included in kits 26C944, 26C946 (Follower plate models)	1
11		Blade, agitator (Follower plate models)	1
12		Washer, paddle, ID8/OD16 (Follower plate models)	3
20		Seal, Reservoir, included in kits 26C943, 26C944, 26C945, 26C946, 2003011	1
21		Plug, M20	0 or 1
22		Pump element, assy, included in kits 26C947, 26C948	1 or 2
23	100721	Plug, 1/4 npt, HEX socket	2
24	555888	Nipple	1
25		Label, overlay	1
34		Cover, bottom	1
39		Label, Series	1
41a		CPC connector, Power and Low Level (Non-Controller Models)	1
41b		CPC connector, Power and Manual Run Button (Controller Models)	1
43		M12 connector, cycle feedback input (Controller Models)	1
44		Plug, M12 (Controller Models)	1
45		Base, Pump	1
50▲	16A579	Label, Warning	1
63a		DIN connector, Low Level (Non-Controller Models)	1
63b		DIN connector, Manual Run Button (Controller Models)	1
64		DIN connector, Power Input	1
67		Holder	1
69		Shaft, square	1
70		Baffle	1
71		Paddle, stirring, assembly	1
72		O-ring (2 L Models)	1

Ref.	Part	Description	Qty.
73		Adapter, reservoir (2 L Models)	1
74		Bracket (2 L Models)	1
75		Fill, Lid, oil models	1
76		Bracket, float, oil models	1
77		Float, oil models	1

▲ Replacement safety labels, tags, and cards are available at no cost.

# Dimensions

Model	Height - A		Width - B		Depth - C	
	Inches	cm	Inches	cm	Inches	cm
0.5 L	10.9	27.7	6.97	17.7	6.57	16.7
1 L (Grease)	12.2	31.0	6.97	17.7	6.57	16.7
2 L (Grease)	14.29	36.3	8.03	20.4	7.72	19.6
1 L (Oil)	13.89	35.3	6.97	17.7	6.57	16.7
2 L (Oil)	15.98	40.6	8.03	20.6	7.72	19.6

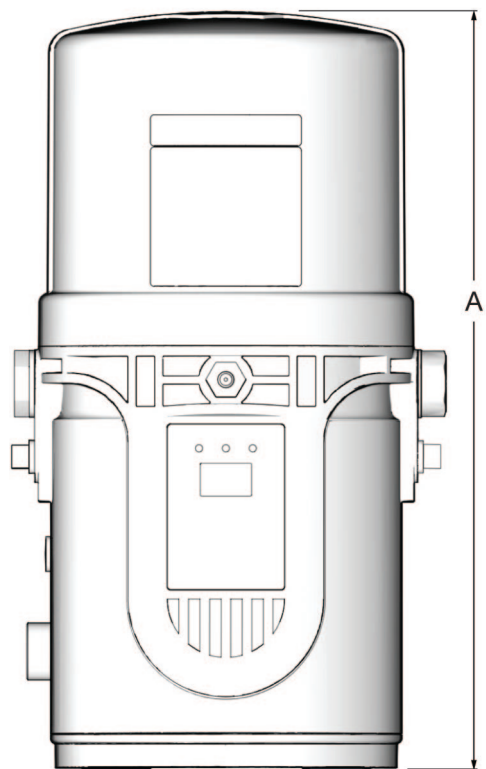
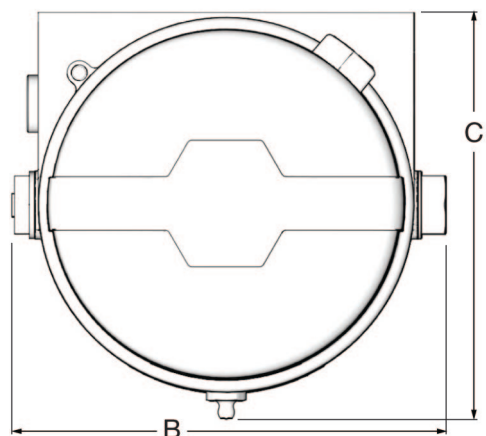

ti35189b

### 0.5 L and 1 L Model Pump Mount CSP Valve Bracket Mount

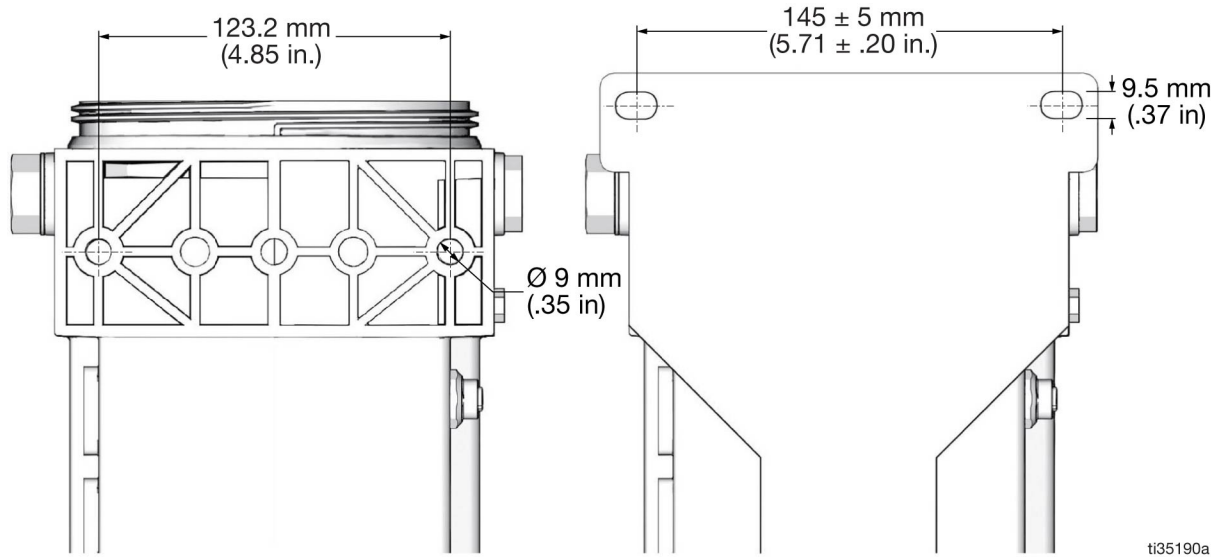

### 2 L Model Pump Mount

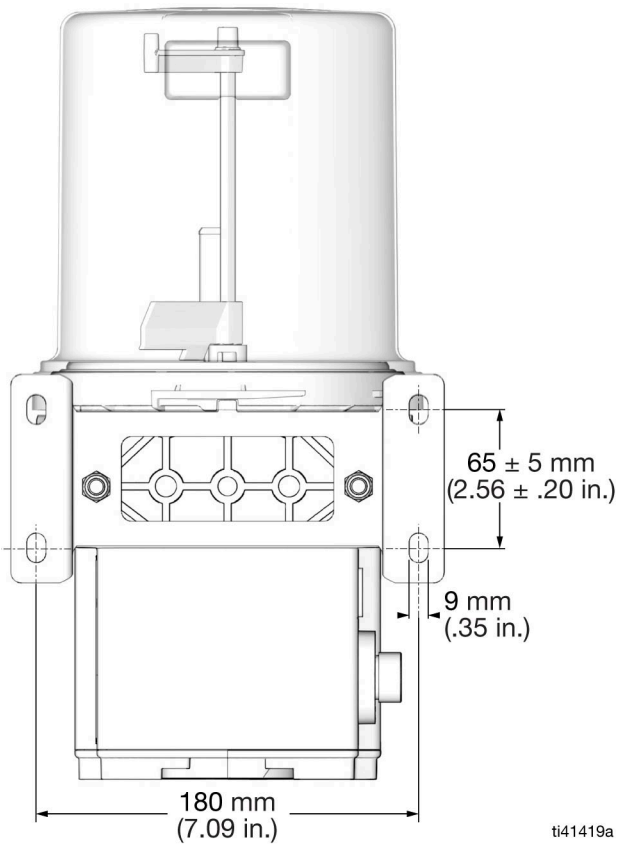

### Universal Bracket Mount

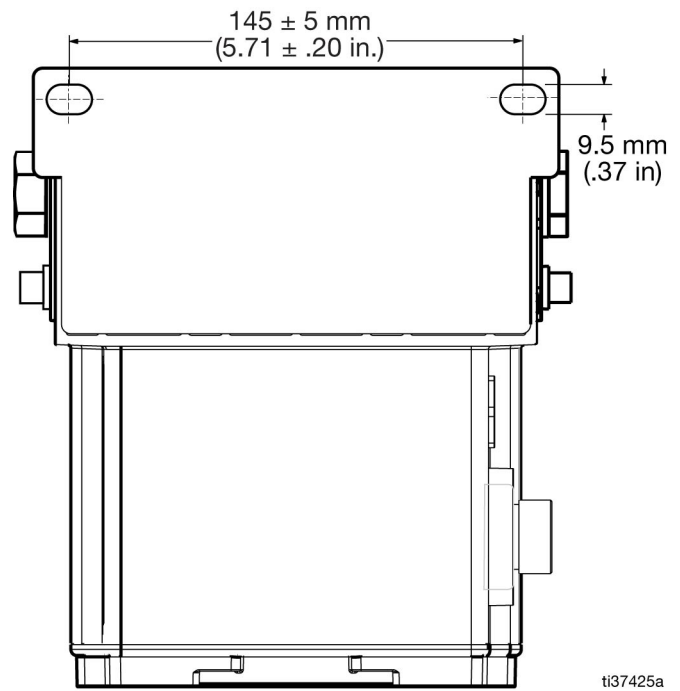

# Technical Specifications

<b>G-MINI Pump</b>		
	<b>US</b>	<b>Metric</b>
Maximum fluid working pressure	4061 psi	28 MPa, 280 bar
<b>Power</b>		
100-240 VAC	100-240 VAC, 0.98 A, 107 VA power, 47/63 Hz, single phase, inrush/locked rotor. max 45 A (1 ms)	
12 VDC	9-16 VDC; 4.0 A (cont) 48W, 9.5 A (peak), 114W, inrush/locked rotor 12 A	
24 VDC	18-32 VDC; 2.0 (cont) 48W, 6.5 A (peak), 156W, inrush/locked rotor 7.5A	
Inputs - Proximity Switch	PNP Style Switch and Cable Only	
Pump Voltage: 12 VDC	11 mA at 12 VDC	
Pump Voltage: 24 VDC	22 mA at 24 VDC	
<b>Outputs - Low Level</b>		
Contact Rating	100W maximum	
Switch Rating	200 VDC maximum	
Switching Current	0.5 A maximum	
Carry Current	1.2 A maximum	
<b>Outputs - Manual Run Button</b>		
Pump Voltage: 12 VDC	11 mA at 12 VDC	
Pump Voltage: 24 VDC	22 mA at 24 VDC	
Pump Output	3.0 cc minute at room temperature with 4061 psi (28 MPa, 280 bar) back pressure	
Pump Outlet	1/4 - NPSF female, compatible with 1/4 NPT fitting	
Reservoir Sizes	0.5 L, 1.0 L, 2.0 L	
IP Rating	IP69K	
<b>Working Temperature*</b>		
Non-Heater Model	5°F to 158°F	-15°C to 70°C
Heater Model	-40 F to 158°F	-40°C to 70°C
<b>Weight</b>		
0.5 L	8.6 lb	3.9 kg
1.0 L	9.0 lb	4.1 kg
2.0 L	9.7 lb	4.4 kg
Wetted parts	carbon steel, alloy steel, stainless steel, nitrile rubber (buna-N), bronze, nickel plated alnico, chemically lubricated acetal, aluminum, PTFE, amorphous polyamide, nylon 6/6 (PA)	
Maximum Sound Pressure	<70 dBa	

\*Achieving the minimum working temperature is contingent on using a temperature compliant grease in an appropriately designed system.

## California Proposition 65

### CALIFORNIA RESIDENTS

 **WARNING:** Cancer and reproductive harm – [www.P65warnings.ca.gov](http://www.P65warnings.ca.gov).

# Graco Standard Warranty

Graco warrants all equipment referenced in this document which is manufactured by Graco and bearing its name to be free from defects in material and workmanship on the date of sale to the original purchaser for use. With the exception of any special, extended, or limited warranty published by Graco, Graco will, for a period of twelve months from the date of sale, repair or replace any part of the equipment determined by Graco to be defective. This warranty applies only when the equipment is installed, operated and maintained in accordance with Graco's written recommendations.

This warranty does not cover, and Graco shall not be liable for general wear and tear, or any malfunction, damage or wear caused by faulty installation, misapplication, abrasion, corrosion, inadequate or improper maintenance, negligence, accident, tampering, or substitution of non-Graco component parts. Nor shall Graco be liable for malfunction, damage or wear caused by the incompatibility of Graco equipment with structures, accessories, equipment or materials not supplied by Graco, or the improper design, manufacture, installation, operation or maintenance of structures, accessories, equipment or materials not supplied by Graco.

This warranty is conditioned upon the prepaid return of the equipment claimed to be defective to an authorized Graco distributor for verification of the claimed defect. If the claimed defect is verified, Graco will repair or replace free of charge any defective parts. The equipment will be returned to the original purchaser transportation prepaid. If inspection of the equipment does not disclose any defect in material or workmanship, repairs will be made at a reasonable charge, which charges may include the costs of parts, labor, and transportation.

**THIS WARRANTY IS EXCLUSIVE, AND IS IN LIEU OF ANY OTHER WARRANTIES, EXPRESS OR IMPLIED, INCLUDING BUT NOT LIMITED TO WARRANTY OF MERCHANTABILITY OR WARRANTY OF FITNESS FOR A PARTICULAR PURPOSE.**

Graco's sole obligation and buyer's sole remedy for any breach of warranty shall be as set forth above. The buyer agrees that no other remedy (including, but not limited to, incidental or consequential damages for lost profits, lost sales, injury to person or property, or any other incidental or consequential loss) shall be available. Any action for breach of warranty must be brought within two (2) years of the date of sale.

**GRACO MAKES NO WARRANTY, AND DISCLAIMS ALL IMPLIED WARRANTIES OF MERCHANTABILITY AND FITNESS FOR A PARTICULAR PURPOSE, IN CONNECTION WITH ACCESSORIES, EQUIPMENT, MATERIALS OR COMPONENTS SOLD BUT NOT MANUFACTURED BY GRACO.** These items sold, but not manufactured by Graco (such as electric motors, switches, hose, etc.), are subject to the warranty, if any, of their manufacturer. Graco will provide purchaser with reasonable assistance in making any claim for breach of these warranties.

In no event will Graco be liable for indirect, incidental, special or consequential damages resulting from Graco supplying equipment hereunder, or the furnishing, performance, or use of any products or other goods sold hereto, whether due to a breach of contract, breach of warranty, the negligence of Graco, or otherwise.

## **FOR GRACO CANADA CUSTOMERS**

The Parties acknowledge that they have required that the present document, as well as all documents, notices and legal proceedings entered into, given or instituted pursuant hereto or relating directly or indirectly hereto, be drawn up in English. Les parties reconnaissent avoir convenu que la rédaction du présente document sera en Anglais, ainsi que tous documents, avis et procédures judiciaires exécutés, donnés ou intentés, à la suite de ou en rapport, directement ou indirectement, avec les procédures concernées.

# Graco Information

For the latest information about Graco products, visit [www.graco.com](http://www.graco.com).

For patent information, see [www.graco.com/patents](http://www.graco.com/patents).

**TO PLACE AN ORDER**, contact your Graco distributor or call to identify the nearest distributor.

**Phone:** 612-623-6928 **or Toll Free:** 1-800-533-9655, **Fax:** 612-378-3590

*All written and visual data contained in this document reflects the latest product information available at the time of publication. Graco reserves the right to make changes at any time without notice.*

Original instructions. This manual contains English. MM 3A6714

**Graco Headquarters:** Minneapolis

**International Offices:** Belgium, China, Japan, Korea

**GRACO INC. AND SUBSIDIARIES • P.O. BOX 1441 • MINNEAPOLIS MN 55440-1441 • USA**  
**Copyright 2020, Graco Inc. All Graco manufacturing locations are registered to ISO 9001.**

[www.graco.com](http://www.graco.com)  
Revision J, June 2024