

XP_s-hf™ Proportioners

3A6283L

EN

Mechanically linked, fixed ratio, plural-component system used for proportioning, mixing, and spraying two component coatings.

For professional use only.

See page 10 for model information and working pressures.

See page 11 for component approvals.



Important Safety Instructions

Read all warnings and instructions in this manual and in related manuals before using the equipment. Save these instructions.

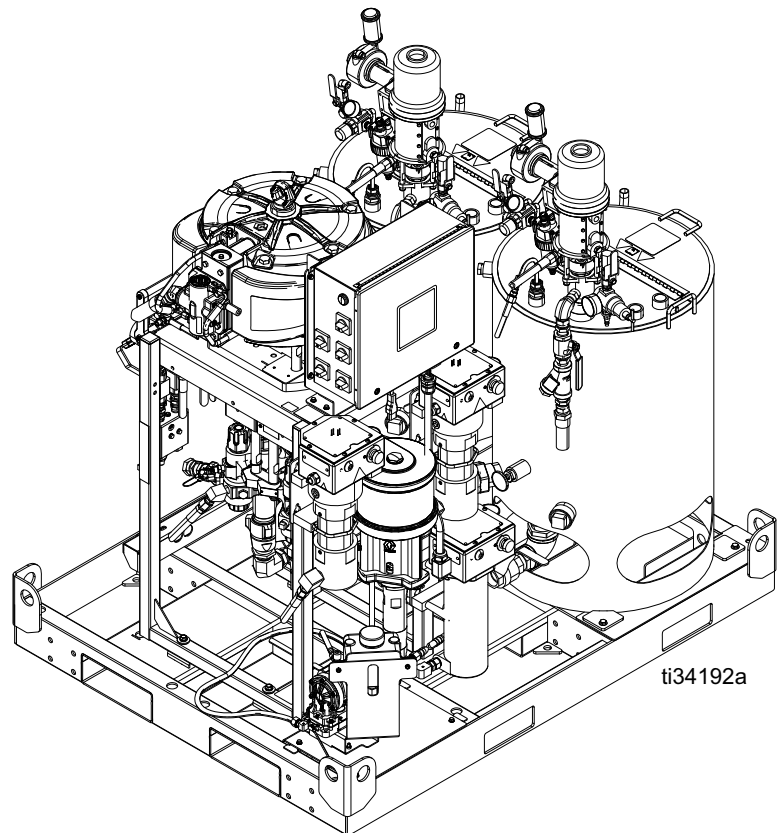

Contents

Related Manuals	3	Maintenance	50
Warnings	4	Hose Electrical Resistance	50
Important Isocyanate (ISO) Information	7	Filters	50
Isocyanate Conditions	7	Seals	50
Keep Components A and B Separate	7	Cleaning Procedure	50
Moisture Sensitivity of Isocyanates	8	Change the Mix Ratio	50
Changing Materials	8	Clean Inlet Strainer Screen	51
Usage	9	Check Heating Fluid Level	51
Models	10	Drain Heating Fluid	51
XPs-hf Systems	11	Feed Pumps	52
Approvals	11	Solvent Pump	52
Component Identification	15	XP Displacement Pumps	52
XPs-hf Proportioners (Model 577101 shown)	15	Agitators	52
Junction Box	17	Troubleshooting	53
Fluid Control Assembly	18	Pump Troubleshooting	55
Main Air Controls	18	Repair	56
Solvent Pump	19	Pump Assembly Repair	56
Heated Hopper Assembly	20	Recirculation Manifold with Over Pressure Relief Valves	57
System Components	21	Replace Over Pressure Relief Valves	58
Air Control Components	21	Parts	60
Fluid Line Components	21	XP50s-hf and XP70s-hf Proportioner	60
Heaters	22	XP50s-hf and XP70s-hf Proportioners (Continued)	61
Pumps	22	XP50s-hf and XP70s-hf Proportioners (Continued)	62
Setup	23	Water Jacketed Heated Hose Packages	64
Initial System Setup	23	Non-Heated Hose Packages	66
Proper Lifting of Sprayer	23	Non-Hazardous Location Electric Heated Hose Packages	68
Grounding	24	Hazardous Location Electric Heated Hose Packages	69
Connect Power Source	25	Air Control Filter 25N583 Parts	71
Connect Explosion-Proof Heaters	27	Air Control Regulator 25N575 Parts	72
Motor Position	27	Solvent Pump 262392 Parts	73
Connect Air Supply	29	Solvent Air Control 24F126 Parts	74
Connecting Heated Hose to Proportioner	29	Heater Block Remote Manifold Kit	75
Connect Static Mixers, Gun, and Hoses	30	Material Recirculation Manifold with Over Pressure Relief Valve	76
Add Heating Fluid to Heated Hoppers	30	Diaphragm Pump 273093 Parts	77
Agitators (ED)	32	XP-hf Pump Assembly Parts	78
Feed Pumps (EE)	32	Recommended Spare Parts	80
Solvent Pump (BA)	33	Accessories and Kits	81
XP Displacement Pumps (D)	33	Dimensions	82
Add Heating Fluid to Hoses	33	System Dimensions	82
Operation	34	Technical Specifications	83
Flush Before Using Equipment	34	End of Product Life	85
Prime the Empty System	34	Graco Standard Warranty	86
Startup/Recirculate	36		
Prime Solvent Pump	38		
Prime the Material Lines	40		
Spray	41		
Adjust the Restrictor	42		
Pressure Relief Procedure	43		
Flushing	44		
Overnight Shutdown	48		
System Verification	49		
Mix and Integration Tests	49		
Appearance Test	49		
Monitor Fluid Supply	49		
Check Pot Life	49		
Ratio Check	49		



Related Manuals







Manuals are available at www.graco.com.





Manuals in English	Description
3A7469	XTR 5+™ and XTR 7+™ Spray Guns, Instructions - Parts
XP-hf Pump Package Components	
334644	Xtreme® XL Air Motor, Instructions - Parts
311762	Xtreme® Displacement Pumps, Instructions - Parts
Hopper Kits	
3A6110	25 Gallon Double-Wall Hopper Kit, Instructions - Parts
3A4032	Xtreme-Duty™ Agitator and Packages, Operation - Parts
307043	Monark® Air Motor, Instructions - Parts
Heating	
3A2954	Viscon® HF Heater, Instructions - Parts
3A7523	XP™ Junction Box, Installation - Parts
Solvent Flush	
310863	Feed and Solvent Flush Kits, Instructions Parts
312794	Merkur® Pump Assembly, Instructions - Parts
Accessories and Kits	
3A3320	XP and XP-hf™ PressureTrak™ Kit, Instruction - Parts
3A1331	XP Pressure Monitor Kit, Instructions - Parts
312769	Feed Pump and Agitator Kits, Instructions - Parts
3A0421	Ratio Check Kit, Instructions - Parts
3A2573	Gun Splitter Valve, Instructions - Parts
Water Heated Hose	
309524	Viscon HP Heater, Instructions - Parts
3A5313	Xtreme-Wrap Water Heated Hose, Instructions - Parts
3A5314	Hose Heat Circulation XP and XP-hf Kit, Instructions - Parts
Electric Heated Hose	
3A0590	Mix Manifold, Quickset Mix Manifold, Instructions - Parts
3A7524	Xtreme-Wrap Electric Heated Hose, Instructions - Parts

Warnings

The following warnings are for the setup, use, grounding, maintenance, and repair of this equipment. The exclamation point symbol alerts you to a general warning and the hazard symbols refer to procedure-specific risks. When these symbols appear in the body of this manual or on warning labels, refer back to these Warnings. Product-specific hazard symbols and warnings not covered in this section may appear throughout the body of this manual where applicable.

 <h2 style="margin: 0;">DANGER</h2>	
 	<p>SEVERE ELECTRIC SHOCK HAZARD</p> <p>This equipment can be powered by more than 240 V. Contact with this voltage will cause death or serious injury.</p> <ul style="list-style-type: none"> • Turn off and disconnect power at main switch before disconnecting any cables and before servicing equipment. • This equipment must be grounded. Connect only to grounded power source. • All electrical wiring must be done by a qualified electrician and comply with all local codes and regulations. • Do not expose to rain. Store indoors.

 <h2 style="margin: 0;">WARNING</h2>	
   	<p>FIRE AND EXPLOSION HAZARD</p> <p>Flammable fumes, such as solvent and paint fumes, in work area can ignite or explode. Paint or solvent flowing through the equipment can cause static sparking. To help prevent fire and explosion:</p> <ul style="list-style-type: none"> • Use equipment only in well ventilated area. • Eliminate all ignition sources; such as pilot lights, cigarettes, portable electric lamps, and plastic drop cloths (potential static sparking). • Ground all equipment in the work area. See Grounding instructions. • Never spray or flush solvent at high pressure. • Keep work area free of debris, including solvent, rags and gasoline. • Do not plug or unplug power cords, or turn power or light switches on or off when flammable fumes are present. • Use only grounded hoses. • Hold gun firmly to side of grounded pail when triggering into pail. Do not use pail liners unless they are anti-static or conductive. • Stop operation immediately if static sparking occurs or you feel a shock. Do not use equipment until you identify and correct the problem. • Keep a working fire extinguisher in the work area.
	<p>SPECIAL CONDITIONS FOR SAFE USE</p> <ul style="list-style-type: none"> • If using the Viscon HP and HF Heaters see manuals for special conditions for safe use. • If using the PressureTrak, see the manual for special conditions for safe use.

 <h1 style="margin: 0;">WARNING</h1>	
	<p>SKIN INJECTION HAZARD</p> <p>High-pressure fluid from gun, hose leaks, or ruptured components will pierce skin. This may look like just a cut, but it is a serious injury that can result in amputation. Get immediate surgical treatment.</p> <ul style="list-style-type: none"> • Do not spray without tip guard and trigger guard installed. • Engage trigger lock when not spraying. • Do not point gun at anyone or at any part of the body. • Do not put your hand over the spray tip. • Do not stop or deflect leaks with your hand, body, glove, or rag. • Follow the Pressure Relief Procedure when you stop spraying and before cleaning, checking, or servicing equipment. • Tighten all fluid connections before operating the equipment. • Check hoses and couplings daily. Replace worn or damaged parts immediately.
	<p>ENTANGLEMENT HAZARD</p> <p>Rotating parts can cause serious injury.</p> <ul style="list-style-type: none"> • Keep clear of moving parts. • Do not operate equipment with protective guards or covers removed. • Do not wear loose clothing, jewelry or long hair while operating equipment.
	<p>MOVING PARTS HAZARD</p> <p>Moving parts can pinch, cut or amputate fingers and other body parts.</p> <ul style="list-style-type: none"> • Keep clear of moving parts. • Do not operate equipment with protective guards or covers removed. • Equipment can start without warning. Before checking, moving, or servicing equipment, follow the Pressure Relief Procedure and disconnect all power sources.



WARNING



EQUIPMENT MISUSE HAZARD

Misuse can cause death or serious injury.

- Do not operate the unit when fatigued or under the influence of drugs or alcohol.
- Do not exceed the maximum working pressure or temperature rating of the lowest rated system component. See **Technical Specifications** in all equipment manuals.
- Use fluids and solvents that are compatible with equipment wetted parts. See **Technical Specifications** in all equipment manuals. Read fluid and solvent manufacturer's warnings. For complete information about your material, request Safety Data Sheet (SDS) from distributor or retailer.
- Do not leave the work area while equipment is energized or under pressure.
- Turn off all equipment and follow the **Pressure Relief Procedure** when equipment is not in use.
- Check equipment daily. Repair or replace worn or damaged parts immediately with genuine manufacturer's replacement parts only.
- Do not alter or modify equipment. Alterations or modifications may void agency approvals and create safety hazards.
- Make sure all equipment is rated and approved for the environment in which you are using it.
- Use equipment only for its intended purpose. Call your distributor for information.
- Route hoses and cables away from traffic areas, sharp edges, moving parts, and hot surfaces.
- Do not kink or over bend hoses or use hoses to pull equipment.
- Keep children and animals away from work area.
- Comply with all applicable safety regulations.



PERSONAL PROTECTIVE EQUIPMENT

Always wear appropriate personal protective equipment and cover all skin when spraying, servicing equipment, or when in the work area. Protective equipment helps prevent serious injury, including long-term exposure; inhalation of toxic fumes, mists or vapors; allergic reaction; burns; eye injury and hearing loss. This protective equipment includes but is not limited to:

- A properly fitting respirator, which may include a supplied-air respirator, chemically impermeable gloves, protective clothing and foot coverings as recommended by the fluid manufacturer and local regulatory authority.
- Protective eyewear and hearing protection.



BURN HAZARD

Equipment surfaces and fluid that is heated can become very hot during operation. To avoid severe burns:

- Do not touch hot fluid or equipment.



TOXIC FLUID OR FUMES HAZARD

Toxic fluids or fumes can cause serious injury or death if splashed in the eyes or on skin, inhaled or swallowed.

- Read Safety Data Sheets (SDSs) for handling instructions and to know the specific hazards of the fluids you are using, including the effects of long-term exposure.
- When spraying, servicing equipment, or when in the work area, always keep work area well-ventilated and always wear appropriate personal protective equipment. See **Personal Protective Equipment** warnings in this manual.
- Store hazardous fluid in approved containers, and dispose of it according to applicable guidelines.

Important Isocyanate (ISO) Information

Isocyanates (ISO) are catalysts used in two component materials.

Isocyanate Conditions



Spraying or dispensing fluids that contain isocyanates creates potentially harmful mists, vapors, and atomized particulates.

- Read and understand the fluid manufacturer's warnings and Safety Data Sheets (SDSs) to know specific hazards and precautions related to isocyanates.
- Use of isocyanates involves potentially hazardous procedures. Do not spray with this equipment unless you are trained, qualified, and have read and understood the information in this manual and in the fluid manufacturer's application instructions and SDSs.
- Use of incorrectly maintained or mis-adjusted equipment may result in improperly cured material. Equipment must be carefully maintained and adjusted according to instructions in the manual.
- To prevent inhalation of isocyanate mists, vapors, and atomized particulates, everyone in the work area must wear appropriate respiratory protection. Always wear a properly fitting respirator, which may include a supplied-air respirator. Ventilate the work area according to instructions in the fluid manufacturer's SDSs.
- Avoid all skin contact with isocyanates. Everyone in the work area must wear chemically impermeable gloves, protective clothing and foot coverings as recommended by the fluid manufacturer and local regulatory authority. Follow all fluid manufacturer recommendations, including those regarding handling of contaminated clothing. After spraying, wash hands and face before eating or drinking.

Keep Components A and B Separate



Cross-contamination can result in cured material in fluid lines which could cause serious injury or damage equipment. To prevent cross-contamination:

- **Never** interchange component A and component B wetted parts.
- Never use solvent on one side if it has been contaminated from the other side.

Moisture Sensitivity of Isocyanates

Exposure to moisture (such as humidity) will cause ISO to partially cure, forming small, hard, abrasive crystal that become suspended in the fluid. Eventually a film will form on the surface and the ISO will begin to gel, increasing in viscosity.

NOTICE

Partially cured ISO will reduce performance and the life of all wetted parts.

- Always use a sealed container with a desiccant dryer in the vent, or a nitrogen atmosphere. **Never** store ISO in an open container.
- Keep the ISO pump wet cup or reservoir (if installed) filled with appropriate lubricant. The lubricant creates a barrier between the ISO and the atmosphere.
- Use only moisture-proof hoses compatible with ISO.
- Never use reclaimed solvents, which may contain moisture. Always keep solvent containers closed when not in use.
- Always lubricate threaded parts with an appropriate lubricant when reassembling.

NOTE: The amount of film formation and rate of crystallization varies depending on the blend of ISO, the humidity, and the temperature.

Changing Materials

NOTICE

Changing the material types used in your equipment requires special attention to avoid equipment damage and downtime.

- When changing materials, flush the equipment multiple times to ensure it is thoroughly clean.
- Always clean the fluid inlet strainers after flushing.
- Check with your material manufacturer for chemical compatibility.
- When changing between epoxies and urethanes or polyureas, disassemble and clean all fluid components and change hoses. Epoxies often have amines on the B (hardener) side. Polyureas often have amines on the B (resin) side.

Usage

The XPs-hf proportioner is a plural component sprayer that can mix and spray most two component epoxy and urethane protective coatings. It is a fixed-ratio system, where XP lowers can be changed to reconfigure the system to different volume mix ratios or spray pressures. See details on page 15.

All models are mounted on a metal skid, and are equipped with heated hoppers where the resin (A material) and catalyst (B material) are heated and pressure fed to the XP-hf pump assembly.

The materials are pumped to the primary heaters, where the resin and hardener are heated to the required spray temperatures. Heat improves the chemical reaction and lowers viscosity to improve the spray pattern.

The materials then flow to the mix manifold assembly. The mix manifold assembly consists of a recirculation manifold, mix manifold, and solvent flush valve. At the recirculation manifold, the materials either recirculate back to the heated hopper for continued heating, or combine at the mix manifold into one fluid line. The mixed material then flows through static mixers for continued mixing to the whip hose and out the spray gun.

The solvent flush system flushes the mixed material out of the manifold, static mixers, mixed material hoses, and spray gun.

When using quick-setting materials (less than 10 minute pot life) a remote mix manifold must be used. The mix manifold is separated from the recirculation manifold and mounted on a remote carriage. Heated hoses are used to prevent temperature loss in the materials while flowing to the remotely mounted mix manifold. Systems are configured to connect either a water heated hose, or an electric heated hose. Heated hoses are sold separately in various configurations and lengths depending on customer need.

Over Pressure Protection



Mechanically linked pumps can create excessive fluid pressure if the full motor force is applied to only one of the fluid pumps.

To reduce the risk of injury due to skin injections, perform the following:

- A maximum air pressure set point blow-off valve is provided to limit maximum fluid pressure. Do not remove these valves.
- Color-coded, automatic, over-pressure relief valves are used to transfer excess fluid pressure back to the supply. Never plug the return hoses. See **Fluid Control Assembly**, on page 18.
- Never install individual shut off valves on the “A” and “B” lines. Common handles link the fluid control valves.
- A rupture disk is provided on the “B” material pump (pumps 145 cc and smaller) as a back-up to the over-pressure relief valve. If the rupture disk ever opens, do not operate the machine until the over-pressure valve and the rupture disc have been replaced.
- If changing pump lowers on your system, use the correct over-pressure relief valves from the chart on page 58.

Models

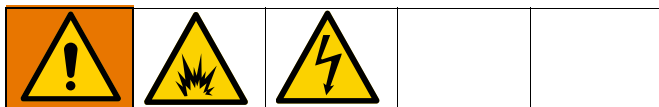

XPs-hf sprayers are not approved for use in hazardous locations unless all components, all accessories, all kits, and all wiring meet local, state, and national code.

NOTE: Not all configurations are available.

PART NUMBER CODE EXAMPLE:

First Three Digits			Fourth Digit	Fifth Digit	Last Digit
+System Pressure Ratio			*Volume Mix Ratio	See ♦ Power Type (Fifth Digit of Part Number); page 11.	See Heated Hose Package (Last Digit of Part Number); page 11.
5	7	x	x	x	x

+System Pressure Ratio (First Three Digits of Part Number)

First Three Digits	System Ratio	Maximum Fluid Working Pressure psi (MPa, bar)
577xxx	70 : 1	7250 (50, 500)
578xxx	50 : 1	5000 (34, 344)

*Volume Mix Ratios - 70:1 (Fourth Digit of Part Number)

Fourth Digit	Pump Ratio (A/B)	A Side Pump	B Side Pump	Combined Fluid Output (cc/cycle)	Fluid Flow at 40 cpm gpm (lpm)	Over-Pressure Relief Valve	Maximum Air Working Pressure psi (MPa, bar)	Fluid to Air Pressure Ratio	Maximum Fluid Working Pressure psi (MPa, bar)
5771xx	1 : 1	L14AC0	L14AC0	290	3.0 (11.3)	Silver	100 (0.7, 7)	71 : 1	7100 (49, 490)
5772xx	2 : 1	L18AC0	L090C0	270	2.8 (10.6)	Silver	95 (0.65, 6.5)	76 : 1	7250 (50, 500)
5773xx	3 : 1	L22XC0	L072C0	292	3.0 (11.3)	Silver	100 (0.7, 7)	71 : 1	7100 (49, 490)
5774xx	4 : 1	L22XC0	L054C0	274	2.8 (10.6)	Silver	95 (0.65, 6.5)	76 : 1	7250 (50, 500)

*Volume Mix Ratios - 50:1 (Fourth Digit of Part Number)

Fourth Digit	Pump Ratio (A/B)	A Side Pump	B Side Pump	Combined Fluid Output (cc/cycle)	Fluid Flow at 40 cpm gpm (lpm)	Over-Pressure Relief Valve	Maximum Air Working Pressure psi (MPa, bar)	Fluid to Air Pressure Ratio	Maximum Fluid Working Pressure psi (MPa, bar)
5781xx	1 : 1	L22AC0	L22AC0	440	4.6 (17.4)	Gold	100 (0.7, 7)	48 : 1	4750 (33, 330)
5782xx	2 : 1	L29AC0	L14AC0	435	4.6 (17.4)	Gold	100 (0.7, 7)	48 : 1	4750 (33, 330)
5783xx	3 : 1	L29AC0	L097C0	387	4.0 (15.1)	Gold	95 (0.65, 6.5)	53 : 1	5000 (35, 345)
5784xx	4 : 1	L29AC0	L072C0	362	3.8 (14.4)	Gold	85 (0.59, 5.9)	59 : 1	5000 (35, 345)

XP-hf Systems

◆ Power Type (Fifth Digit of Part Number)

Fifth Digit	VAC	Environment
xxxx0x	240	Non-Hazardous/Ordinary Locations
xxxx1x	240	Class I, Division 1
xxxx2x	480	Non-Hazardous/Ordinary Locations
xxxx3x	480	Class I, Division 1

Heated Hose Package (Last Digit of Part Number)



Sixth Digit	Water Hose Heat with Circulation Pump	Electric Heated Hose
xxxxx1	✓	
xxxxx2		
xxxxx3		✓



Approvals



XP-hf System Approvals



System	Approvals
57xx0x	
57xx1x	System is intended for hazardous locations with the classification of Class I, Division 1, Group D T3 0°C to 54°C
57xx2x	
57xx3x	System is intended for hazardous locations with the classification of Class I, Division 1, Group D T3 0°C to 54°C

Component Level Approvals



Primary Heaters		North American Location		European Atmosphere		Approvals
Component	Description	Non-Hazardous	Hazardous	Non-Explosive	Explosive	
26C476	480V HF Ex	✓	✓	✓	✓	 <p>Intertek 5024314 Class I, Division 1, Groups C, D (T3) Ta = -20°C to 60°C</p> <p>KCS Certificate No: 18-KA4B0-0073X</p>
24W248	240V HF Ex	✓	✓	✓	✓	<p>ATEX Ratings:  II 2 G Ex db IIB T4 Gb</p> <p>ATEX Certificate No. ITS14ATEX18155X ITS21UKEX0367X</p> <p>IECEX Ratings EX db IIB T4 Gb IECEX Certificate No. IECEX ETL 14.0046X Ta = -20°C to 60°C</p>
24P016	240V HF Non-Hazardous	✓		✓		 <p>Intertek 5024314 Certified to CAN/USA C22.2 No. 88 Conforms to UL499</p>
26C475	480V HF Non-Hazardous	✓		✓		

Solvent Pump		North American Location		European Atmosphere		Approvals
Component	Description	Non-Hazardous	Hazardous	Non-Explosive	Explosive	
262392	Solvent Pump	✓	✓	✓	✓	 <p> II 2 G Ex h IIB T6 Gb</p>

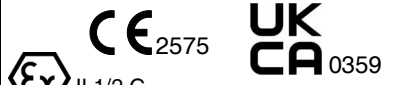
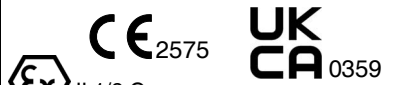
Junction Box		North American Location		European Atmosphere		Approvals
Component	Description	Non-Hazardous	Hazardous	Non-Explosive	Explosive	
Hazardous Location Junction Box		✓	✓			 Class I, Division 1, Groups B, C, & D UL 1203/CSA C22.2 No. 25 & 30
26C583	480V Hazardous Location Junction Box	✓	✓			Designed to Standards: UL 60079-0 UL 60079-25
26C906	480V Hazardous Location Junction Box, Electric Hose Heat	✓	✓			
26C581	240V Hazardous Location Junction Box	✓	✓			
26C905	240V Hazardous Location Junction Box, Electric Hose Heat	✓	✓			
Ordinary Location Junction Box		✓		✓		 Intertek 5024314 Conforms to UL STD 508A Certified to CAN/CSA C22.2 No. 286
26C582	480V Junction Box	✓		✓		
26C904	480V Junction Box, Electric Hose Heat	✓		✓		
26C580	240V Junction Box	✓		✓		
26C899	240V Junction Box, Electric Hose Heat	✓		✓		

Heated Hopper Assembly		North American Location		European Atmosphere		Approvals
Component	Description	Non-Hazardous	Hazardous	Non-Explosive	Explosive	
25P239	Immersion Heaters, 480V	✓	✓			 For US/CAN: Class I, Division 1, Groups B, C, & D (T4)
25N577	Immersion Heaters, 240V	✓	✓			 For US/CAN: Class I, Division 1, Groups B, C, & D (T4)
25N584	5:1 Monark Pump	✓	✓	✓	✓	 II 1/2 G Ex h IIb T2 Ga/Gb ETL23ATEX0276 ITS21UKEX0322
25N588	Xtreme Duty Hopper Agitator	✓	✓	✓	✓	 II 1/2 G Ex h IIb T4 Ga/Gb ITS16ATEX100984X ITS21UKEX0262X

Models

Heated Hose (sold separately)		North American Location		European Atmosphere		Approvals
Component	Description	Non-Hazardous	Hazardous	Non-Explosive	Explosive	
See your water heated hose manual for complete list of part numbers	Water Jacketed	✓	✓	✓	✓	
See your electric heated hose manual for complete list of part numbers	Electric	✓	✓	✓		

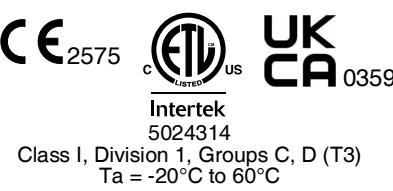
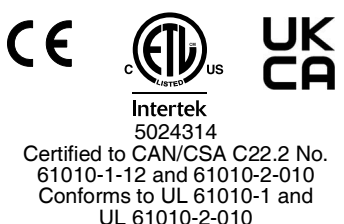
Hot Water Heater		North American Location		European Atmosphere		Approvals
Component	Description	Non-Hazardous	Hazardous	Non-Explosive	Explosive	
245864	480V HP Hazardous	✓	✓	✓	✓	
245863	240V HP Hazardous	✓	✓	✓	✓	
245869	240V HP Non-Hazardous	✓		✓		
245870	480V HP Non-Hazardous	✓		✓		

273093 Circulation Pump Kit		North American Location		European Atmosphere		Approvals
Component	Description	Non-Hazardous	Hazardous	Non-Explosive	Explosive	
24T461	Diaphragm Pump	✓	✓	✓	✓	

Component Identification

XP-hf Proportioners (Model 577101 shown)

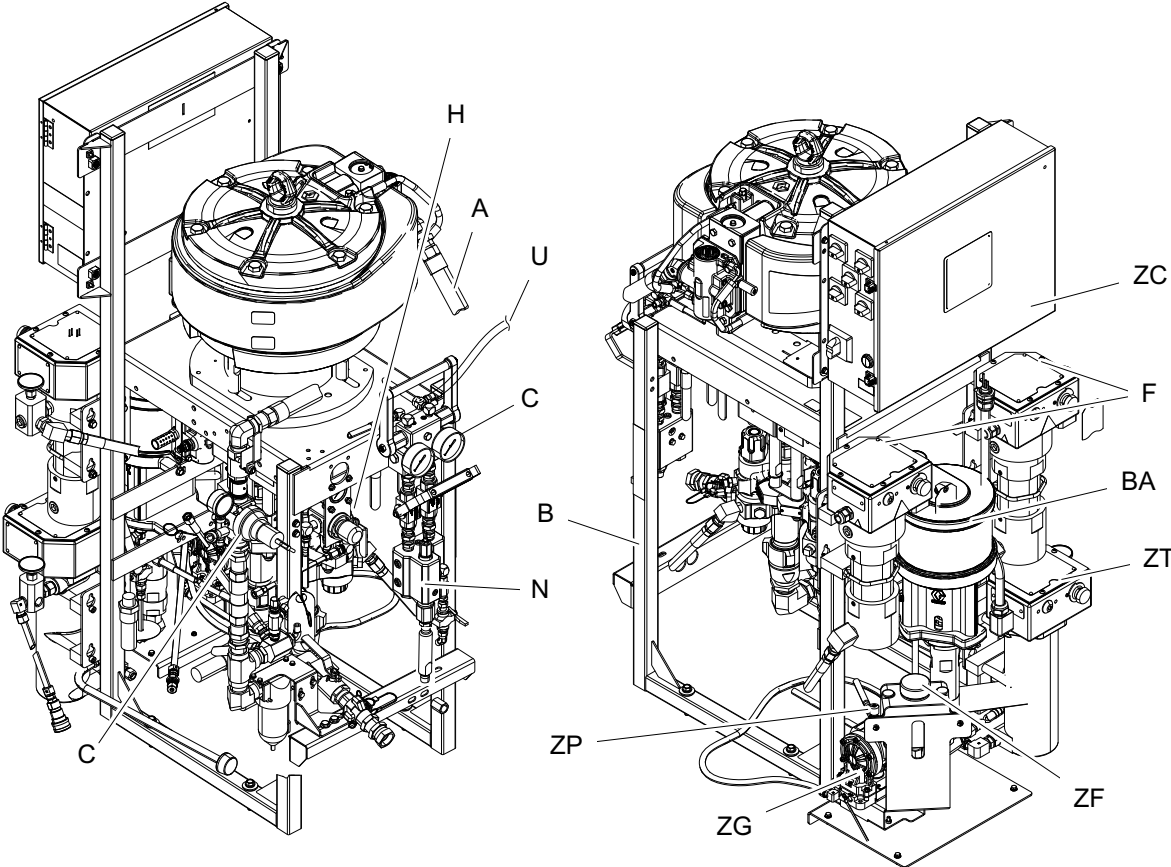

XP-hf Pump Assembly

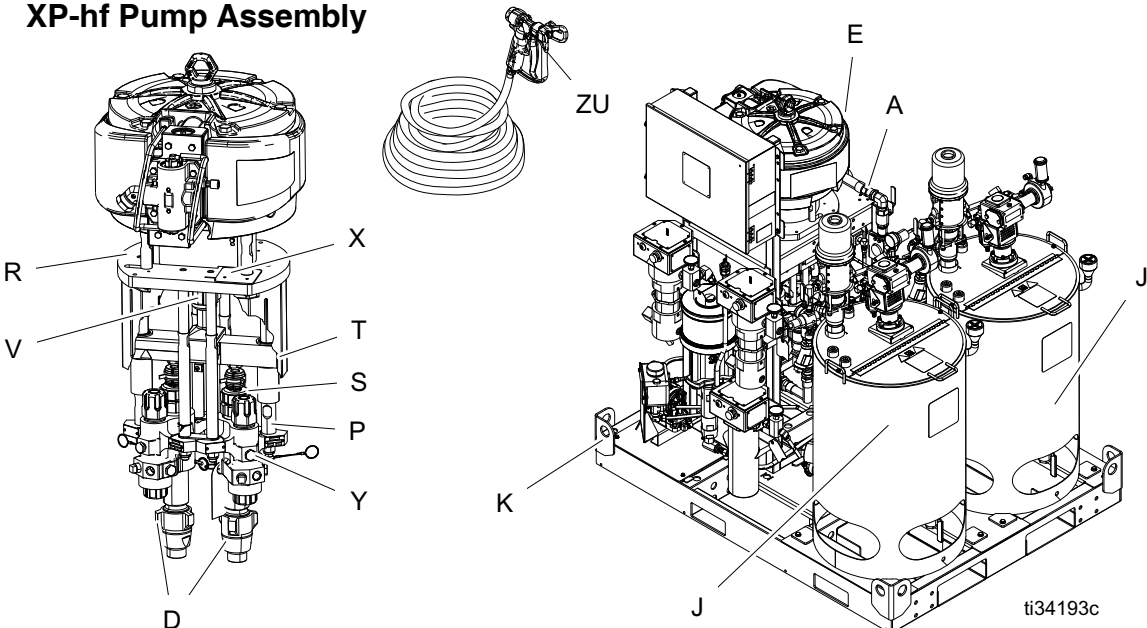

Component Identification

Key:

A	XP-hf Motor Air Supply Hose	T	Yoke with Rod Bearings
B	Stand	U	Recirculation Lines
C	Main Air Controls , see page 18	X	Motor Position Indicator Bracket
D	XP Displacement Pump	V	Connecting Rod Nut
E	Xtreme XL Air Motor	Y	Over-Pressure Rupture Disk; (for pumps that are 145cc or smaller)
F	Primary Heaters	BA	Solvent Pump, see page 19
H	Solvent Pump Controls; see page 19	ZC	Electrical Enclosure, see page 17
J	Heated Hopper Assembly; see page 20	ZF	Hot Water Reservoir (if equipped)
K	Frame, Skid	ZG	Diaphragm Pump (if equipped)
N	Fluid Control Assembly; see page 18	ZP	Diaphragm Pump Needle Valve (if equipped)
P	Pump Tie Rods	ZT	Hot Water Heater (if equipped)
R	Motor Adapter Plate	ZU	Mixed Material Gun and Hose
S	Adjustable Packing Nuts with Wet Cups		

Junction Box

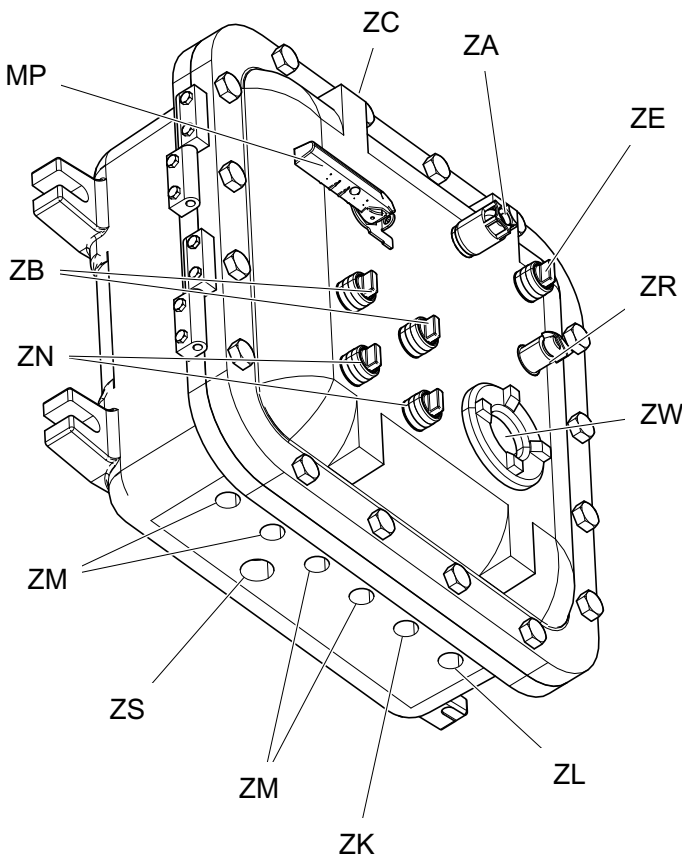
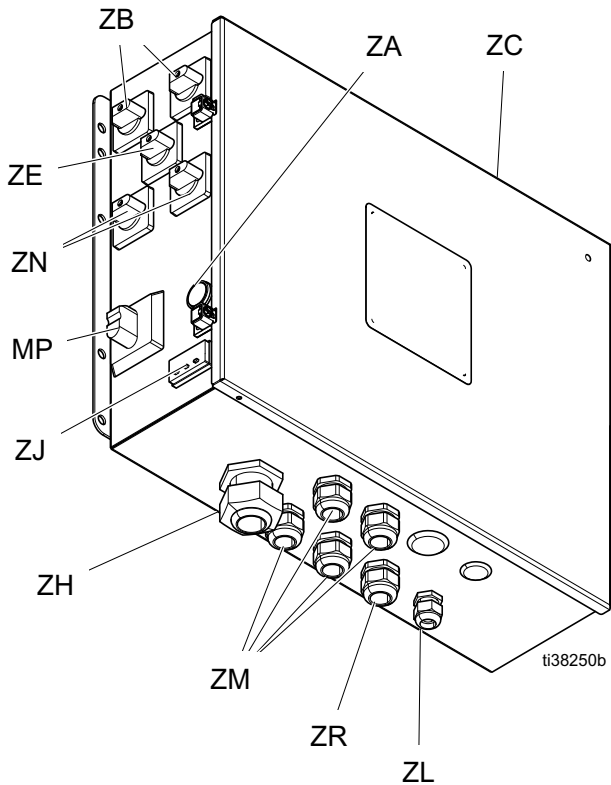

Key:

- MP Main Power Switch
- ZA Power Indicator Light
- ZB Primary Heater Switches
- ZC Electrical Enclosure
- ZE Hose Heater Switch
- ZH Strain Relief (Non-hazardous locations only)
- ZJ Electric Heated Hose Temperature Controller / Display (Non-hazardous locations only)

- ZK Hose Heater Harness Entry Point
- ZL Thermocouple Sensor Entry Point
- ZM Fluid Heater and Hopper Heater Harness Entry Point
- ZN Hopper Heater Switches
- ZR Electric Heated Hose Temperature Controller (Hazardous locations only)
- ZS Main Power Entry Point
- ZW Temperature Display (Hazardous locations only)

Fluid Control Assembly

Shown with water-heated hose configuration

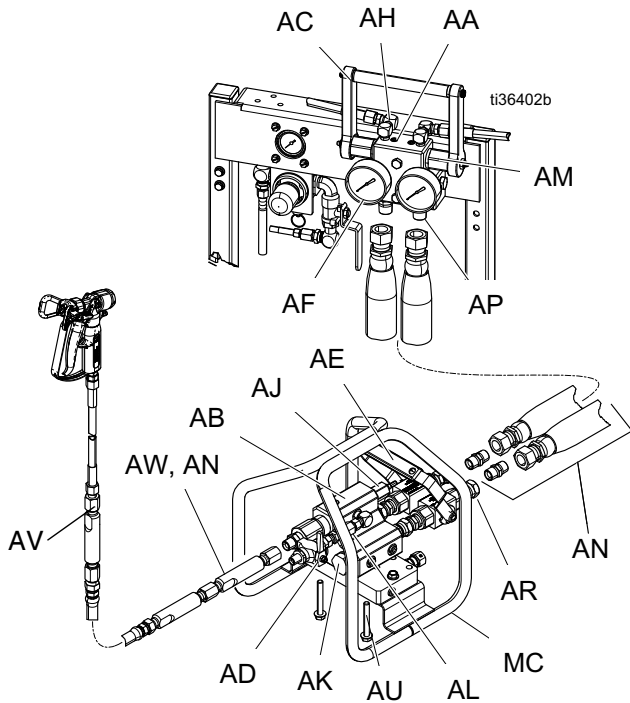

Key:

- AA Recirculation Manifold
- AB Mix Manifold
- AC Recirculation Handle (shown closed), see page 21.
- AD Solvent Flush Valve
- AE Dual Shutoff Handle (shown closed)
- AF Fluid Pressure Gauges
- AH Fluid Recirculation Fittings
- AJ B Component Adjustable Fluid Restrictor; see page 42
- AK A and B Mix Manifold Check Valves
- AL Solvent Inlet Check Valve
- AM Automatic, Spring Loaded, Color-Coded, Over-Pressure Relief Valves; with grease fittings
- AN Static Mixer Tubes; 3/8 npt(m)
- AP Recirculation Manifold Outlet
- AR Mix Manifold Inlet
- AW Primary Static Mixer Tubes
- AV Cleanup Static Mixer Tube
- AU Long Fasteners (shipped loose with Remote Manifold kit)
- MC Remote Manifold Carriage

Main Air Controls

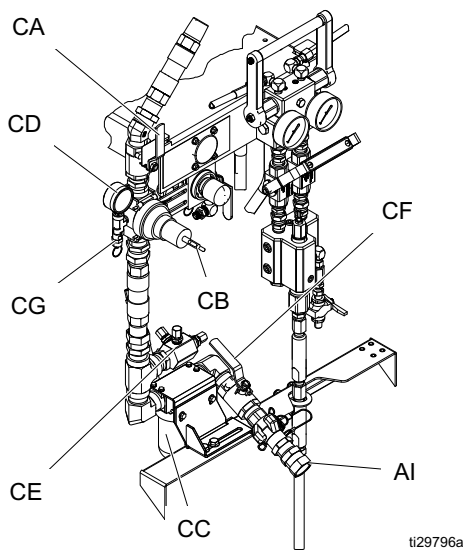

Key:

- AI Main Air Inlet
- CA Motor Air Valve
- CB Motor Air Pressure Regulator
- CC Air Filter with Auto Drain
- CD Main Motor Air Pressure Gauge
- CE Filtered Air Distribution Manifold
- CF Main Air Shutoff Valve
- CG XP-hf Motor Air Pressure Relief Valve

Solvent Pump

Pump

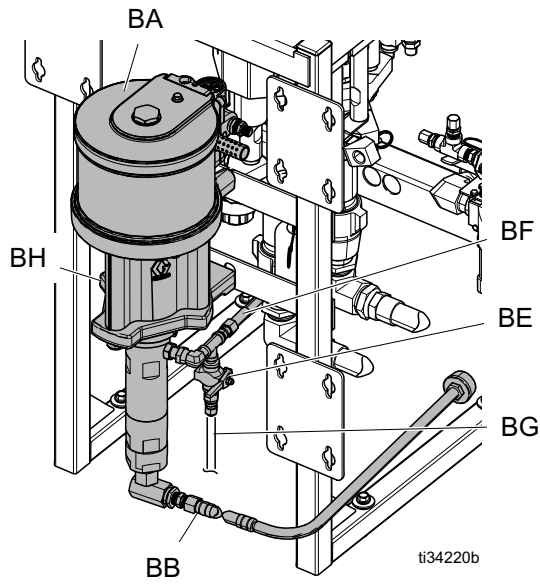

Key:

- BA Solvent Pump
- BB Siphon Tube
- BE Solvent Prime Valve
- BF Solvent Supply Hose
- BG Solvent Prime Hose
- BH Solvent Pump Wet Cup

Air Controls

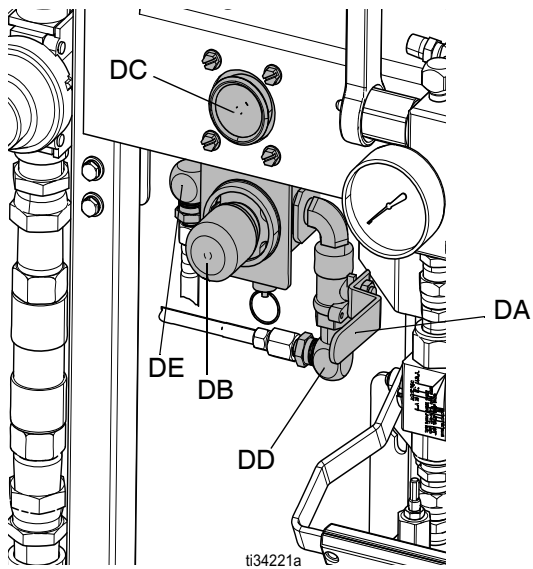

Key:

- DA Solvent Air Shutoff Valve (Relieving)
- DB Solvent Air Pressure Regulator
- DC Solvent Air Pressure Gauge
- DD Solvent Air Outlet
- DE Solvent Air Inlet

Heated Hopper Assembly

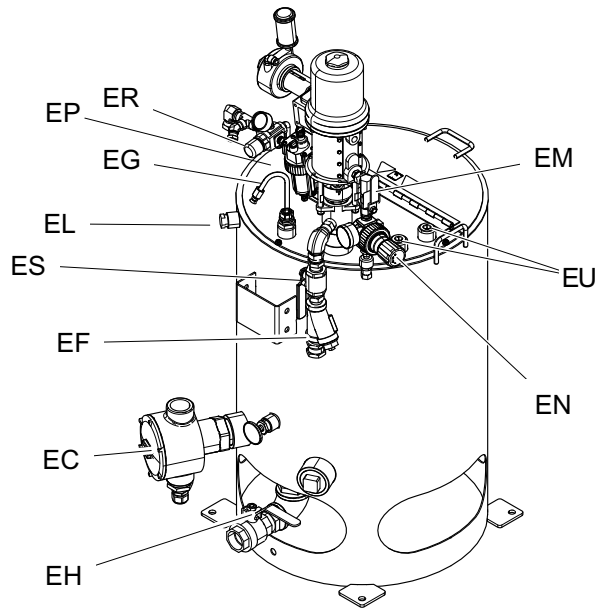
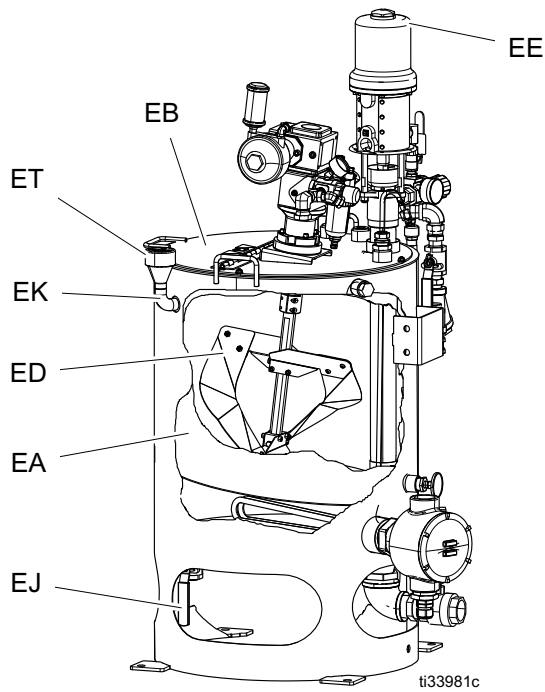

Key:

- EA Double-Wall Hopper
- EB Hopper Lid
- EC Hopper Heater
- ED Agitator
- EE Feed Pump
- EF Y-Strainer
- EG Recirculation Tube
- EH Material Drain
- EJ Heating Fluid Drain Valve

- EK Heating Fluid Fill Port
- EL Heating Fluid Vent
- EM Air Valve (Feed Pump)
- EN Air Regulator (Feed Pump)
- EP Air Valve (Agitator)
- ER Air Regulator (Agitator)
- ES Y-Strainer Valve
- EU Accessory Ports

System Components

Air Control Components

XP-hf Motor Air Valve (CA)



Trapped air can cause the pump to cycle unexpectedly, which could result in serious injury from splashing or moving parts. Use the XP-hf Motor Air Valve (CA) to relieve trapped air.

Be sure the valve is easily accessible from the pump and located downstream from the air regulator (CB).

To relieve air trapped between the air motor when the valve is closed:

1. Open the valve to supply air to the motor.
2. Close the valve to shut off air to the motor, and bleed any trapped air from the motor.

XP-hf Motor Air Pressure Relief Valve (CG)

Automatically opens to relieve air pressure if supplied pressure exceeds preset limit. Use the correct air pressure relief valve for the system ratio:

XP70s-hf		XP50s-hf	
Ratio	Valve Part	Ratio	Valve Part
1:1	113498	1:1	113498
2:1	114055	2:1	113498
3:1	113498	3:1	114055
4:1	114055	4:1	16M190

Main Air Filter (CC)

Removes harmful dirt from compressed air supply. A minimum 40 micron filter is used.

XP-hf Motor Air Pressure Regulator (CB)

Adjusts air pressure to the motor and fluid outlet pressure of pump. Locate the air regulator close to the pump. Read air pressure on the gauge.

Main Air Shutoff Valve (CF)

Controls the flow of inlet air. Close main air shutoff valve to stop all components and pumps.

Fluid Line Components

Recirculation Manifold (AA)

Controls recirculation and pump priming.

Mix Manifold (AB)

Combines A and B fluid into one fluid line.

Recirculation Handle (AC)

Directs fluid flow for recirculation or mixing. Move to open position to relieve fluid pressure, prime pumps, and circulate material in hoppers. Move to closed position to spray mixed material.

Dual Shutoff Handle (AE)

Controls A and B fluid flow for mixing and dispensing. Close before flushing.

Solvent Flush Valve (AD)

Controls solvent flow to the mix manifold, hose, and spray gun.

Static mixer (AV, AW)

Thoroughly mixes the two fluids and delivers the mixed fluid to the spray gun.

Heaters

Primary Heaters (F)

Viscon HF Fluid Heaters heat resin and hardener before the materials combine in the mix manifold assembly. The heater improves chemical reaction and lowers viscosity of material to improve the spray pattern. There are two Viscon HF heater variants (hazardous location heaters, and non-hazardous location heaters). For approval rating, see **Approvals**, page 11 regarding your primary fluid heaters.

Hot Water Heater (ZT)

Viscon HP Fluid Heater is included in the water heated hose packages. Heating fluid is circulated by a diaphragm pump through the heater and into the water jacketed lines surrounding the material hoses. There are two Viscon HP heater variants (hazardous location heaters and non-hazardous location heaters). For approval rating, see **Approvals**, page 14, regarding your primary fluid heaters.

Hopper Heaters (EC)

Immersion heaters used to heat the outer jacketed area of the double walled hoppers. The outer jacket is filled with heating fluid to condition the resin and hardener materials.

Pumps

XP-hf Pump Assembly

A mechanically linked, fixed-ratio system that consists of a singular air motor and two individual XP displacement pumps.

XP Displacement Pump (D)

Pump used to deliver the resin and hardener materials at high pressure to the mix manifold and spray gun.

Solvent Pump (BA)

Pump used to flush the mix manifold, hose, and gun.

Feed Pumps (EE)

Pumps that transfer conditioned resin and hardener materials to the primary pump. Using feed pumps is the preferred method to transfer viscous material compared to the gravity feed method.

Diaphragm Pump (ZG)

Pump equipped on water heated hose packages, used to circulate the heating fluid through the water heated hose.

Setup

Initial System Setup



1. Check the shipment for accuracy. Ensure you have received everything you ordered. See **Component Identification**, page 15.
2. Check for loose fittings and fasteners.
3. If any accessories are added, refer to their **Related Manuals** listed on page 3 for all warnings and instructions.
4. Confirm air supply requirements. This system requires a 1.0 in. airline.
5. Confirm electric power requirements and make sure a properly sized electrical cord is used.

NOTE: A minimum of 25 gallons (95 liters) of heating fluid is needed. Additional heating fluid is needed if water heated hose is used.

NOTE: A minimum of 10 gallons (39 liters) of “A” and “B” materials are needed to load the hoppers and prime the system.

NOTE: A minimum of 25 gallons (95 liters) of solvent is required for flushing.

NOTE: Empty metal pails for both “A” and “B” materials are required for flushing.

Location

1. Locate the proportioner on a level surface. Follow the **Proper Lifting of Sprayer** procedure.
2. Position the proportioner for convenient operator access and maintenance, proper routing of air and fluid lines, and easy connection of components and accessories.

Proper Lifting of Sprayer



Follow these instructions to help prevent serious injury or damage to equipment. Never lift while a hopper is filled.

NOTICE

To prevent spilling and to ensure even weight distribution, drain all fluid prior to lifting the proportioner.

Lift Using a Forklift

The proportioner can be raised and moved using a forklift. Disconnect power and air from the system. Carefully lift the proportioner; make sure it balances evenly.

Lift Using a Hoist

- Lift the system with a lift apparatus rated appropriately for the weight of the system (see **Technical Specifications**, page 83).
- Do not lift the system by the handle on the hoppers or air motor lift ring.
- Lift the system using the lift eyes shown in the lifting illustration.

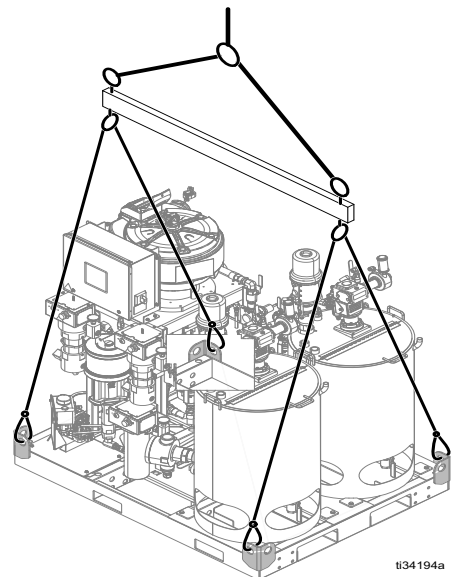

t34194a

Grounding



The equipment must be grounded to reduce the risk of static sparking and electric shock. Electric or static sparking can cause fumes to ignite or explode. Improper grounding can cause electric shock. Grounding provides an escape wire for the electric current.

System: Connect the supply ground wire in the electrical compartment as shown in **Connect Power Source** on page 25.

Pump: Connect ground wire 244524 (GW) to the ground stud (GS) on the air motor (E).

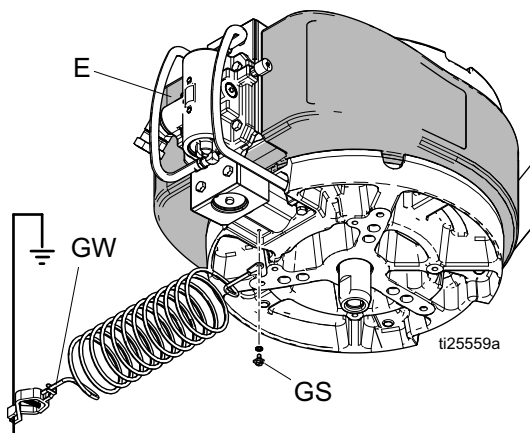

Connect the other end of the ground wire to a true earth ground for system without heaters, otherwise connect to HF heater clamp bar.

Air and fluid hoses: Use only electrically conductive hoses with a maximum of 300 ft (91 m) combined hose length to ensure grounding continuity. Check electrical resistance of hoses regularly. If total resistance to ground exceeds 29 megohms, replace hose immediately.

Spray gun: Ground through connection to a properly grounded fluid hose and pump.

Solvent pails: Follow your local code. Use only metal pails, which are conductive, placed on a grounded surface. Do not place pail on a non-conductive surface, such as paper or cardboard, which interrupts grounding continuity.

To maintain grounding continuity when flushing or relieving pressure: Hold the metal part of the spray gun firmly to the side of a grounded metal pail, then trigger the gun.

Work area: Ground the object being sprayed, fluid supply container, and all other equipment in the work area.

Air compressor: Follow manufacturer's recommendations.

Object being sprayed: Follow your local code.

Material supply container: Follow your local code.

Connect Power Source

NOTE: Required voltage and amperage is noted on the control panel label. See **Power Cord Guidelines** tables below.



To help prevent injury from electric shock, turn off and disconnect power at the main switch before connecting any cables and before servicing equipment. All electrical work must be done by a qualified electrician and comply with local codes and regulations.

Use the intended entry locations shown in **Junction Box**, page 17.

1. Turn the main power switch (MP) off.
2. Open the junction box door.
3. **Non-Hazardous Locations only:** Route the power cord through the strain relief (ZH) into the electrical enclosure (ZC).

Hazardous Locations only: Follow local codes and regulations for routing the power through the main power entry point (ZS).

Power Cord Guidelines

Use the guidelines listed in the table below to determine the power cord needed for your specific system.

Models with 240 Volt Viscon HF Fluid Heater						
Junction Box	Full Load Peak Amperes (A)					
	xxxx01	xxxx11	xxxx02	xxxx12	xxxx03	xxxx13
240 V, 1 Phase	87	87	71	71	84	84
240 V, 3 Phase	76	76	65	65	73	73
380 V, 3 Phase	48	48	48	48	48	48
480 V						

Models with 480 Volt Viscon HF Fluid Heater						
Junction Box	Full Load Peak Amperes (A)					
	xxxx21	xxxx31	xxxx22	xxxx32	xxxx23	xxxx33
240 V, 1 Phase						
240 V, 3 Phase						
380 V, 3 Phase						
480 V	28	28	26	26	27	27

NOTE: The machine is provided with jumpers in the 380 Vac 3-Phase Wye position.

NOTE: Terminal jumpers are not used for 480V.

4. Connect the ground wire to the ground terminal (G).
 5. Connect the power cord to the disconnect as shown in **XP_s-hf Wiring Diagram**, page 26. Gently pull on all connections to verify that they are properly secured.
 6. **Non-Hazardous Locations only:** Tighten the strain relief (ZH).
- Hazardous Locations:** Follow local codes and regulations for sealing the power cable entering into the enclosure.
7. Install the supplied terminal jumpers in the positions shown in the **XP_s-hf Wiring Diagram**, page 26.
 8. Verify that all items are connected properly as shown in the **XP_s-hf Wiring Diagram**, page 26, then close the electrical enclosure (ZC) door.

XPs-hf Wiring Diagram

NON-HAZARDOUS LOCATIONS

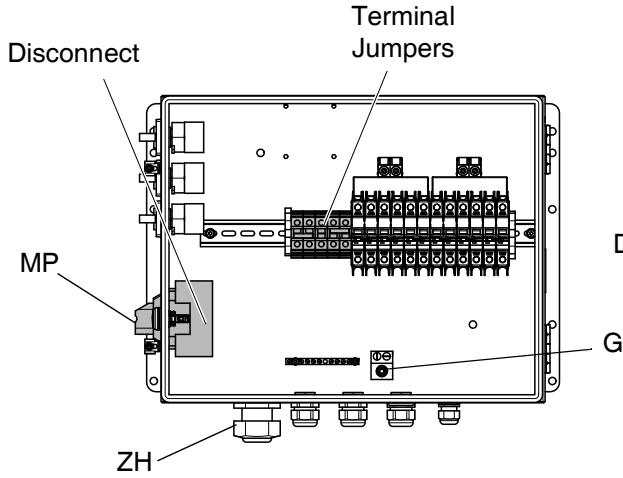

HAZARDOUS LOCATIONS

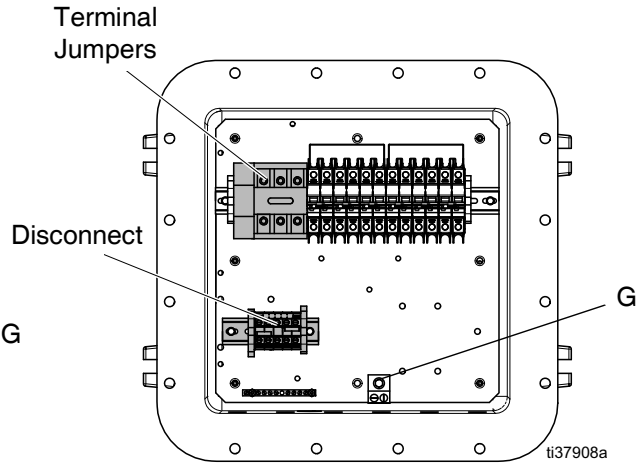

230 Vac
1-Phase Delta

230 Vac
3-Phase Delta

380 Vac
3-Phase Wye

480 Vac
3-Phase Delta

Disconnect

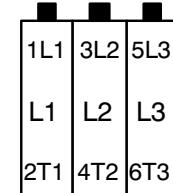
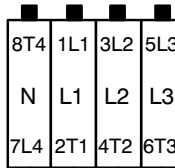
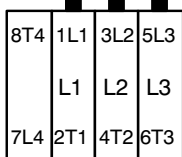
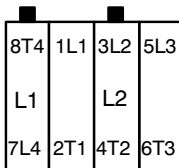

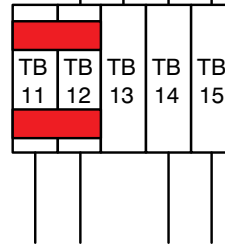
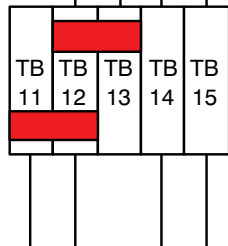
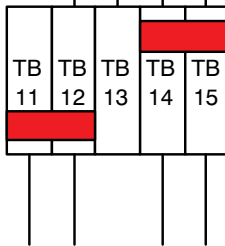

Terminal
Jumpers



Connect Explosion-Proof Heaters

Hazardous location proportioners only (xxx1x, xxxx3x)

				
---	---	---	--	--

If your sprayer is intended for hazardous locations, a qualified electrician must connect the explosion-proof heater wiring. Ensure wiring and installation comply with local electrical codes and regulations.

Improperly installed or connected equipment may result in fire, explosion, or electric shock. Follow all local codes and regulations.

Ensure wiring, wiring connections, switches, and electrical distribution panel all meet flame-proof (explosion-proof) installation requirements.

Refer to your Junction Box manual for the wiring diagram for hazardous locations.

Refer to your Viscon HP heater manual for electrical connection instructions and guidelines in hazardous locations.

Refer to your Viscon HF heater manual for electrical connection instructions and guidelines in hazardous locations.

Motor Position

The motor position must be set for the volume mix ratio of the system.

NOTE: Changing the motor position does not change the mix ratio.

Check Motor Position

1. Verify that the correct pumps are mounted for your volume mix ratio. See the **Models** chart on page 10.

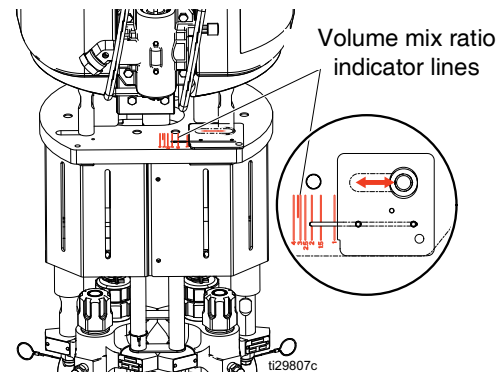

2. Verify that the motor position is adjusted correctly for that volume mix ratio. If not, perform the following **Change Motor Position** procedure.

Change Motor Position

There are specific motor positions for each mix ratio setting. To Adjust the position of the air motor:

1. Verify that the XP-hf motor air valve (CA) is closed.
2. Perform the **Check Motor Position** procedure. If the position is incorrect, continue to the next step.
3. Loosen the eight fasteners and remove the two pump guards.

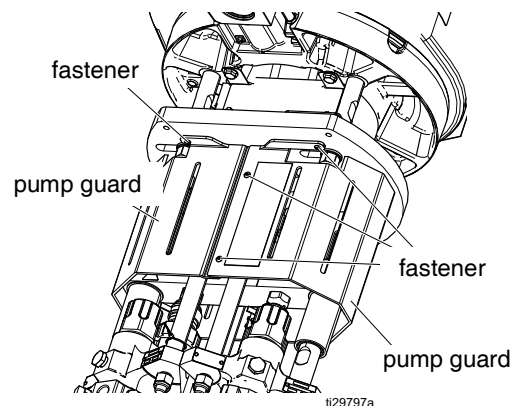

Setup

- Loosen the three nuts below the motor tie rods (P).

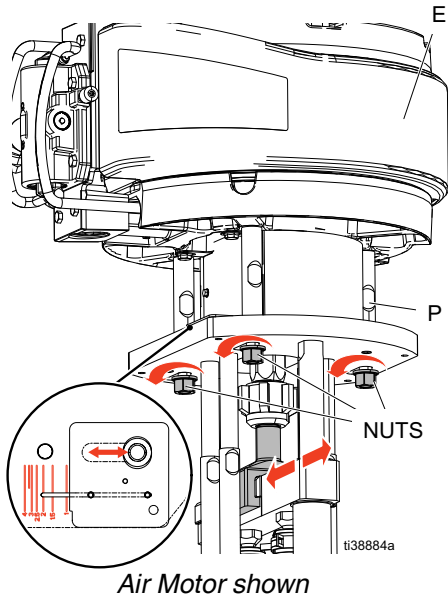

- Slide the tie rods (P) and motor (E) until the indicator lines are aligned with your ratio.

NOTICE

Do not hit the tie rods (P) with a hammer. Damage to the air motor base may result.

- Tighten the three nuts.
- Install the pump guards.

Connect Air Supply

Connect the air supply hose to the main air inlet (AI).

Use a 1.0 in. (25.4 mm) ID minimum air hose. Do not use pin fitting type quick disconnect.

Connect any air-powered accessories to the accessory port (CM).

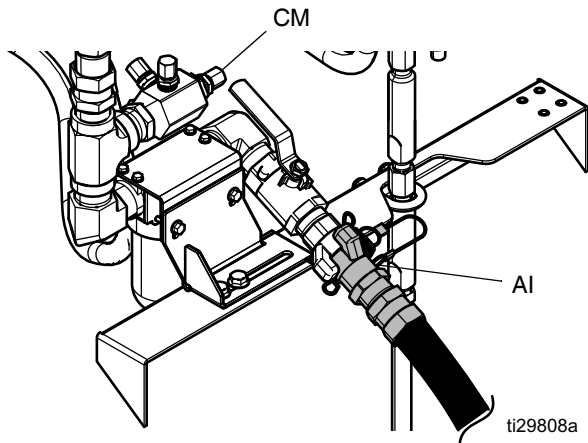

Connecting Heated Hose to Proportioner

1. Disconnect the solvent outlet hose (BF) and elbow fitting (BK) from the solvent flush valve (AD).
2. Loosen the union fittings (AR) on the mix manifold inlet that connect to the recirculation manifold (AA) to disconnect the mix manifold (AB).

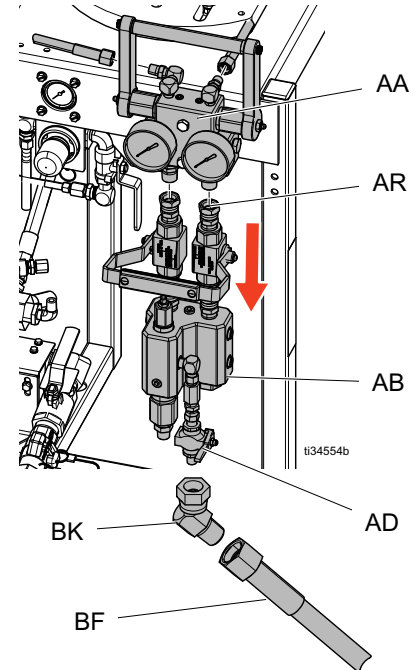

3. **For water jacketed heated hoses**, follow **Connect Static Mixers, Gun, and Hoses**, page 30.
4. **For electric heated hoses**, see your heated hose manual for installation. See **Related Manuals**, page 3.

Connect Static Mixers, Gun, and Hoses

1. Connect the outlet of the two primary static mixer tubes (AW) to the gun and hose assembly (ZU).
2. Check that all connections are tight.

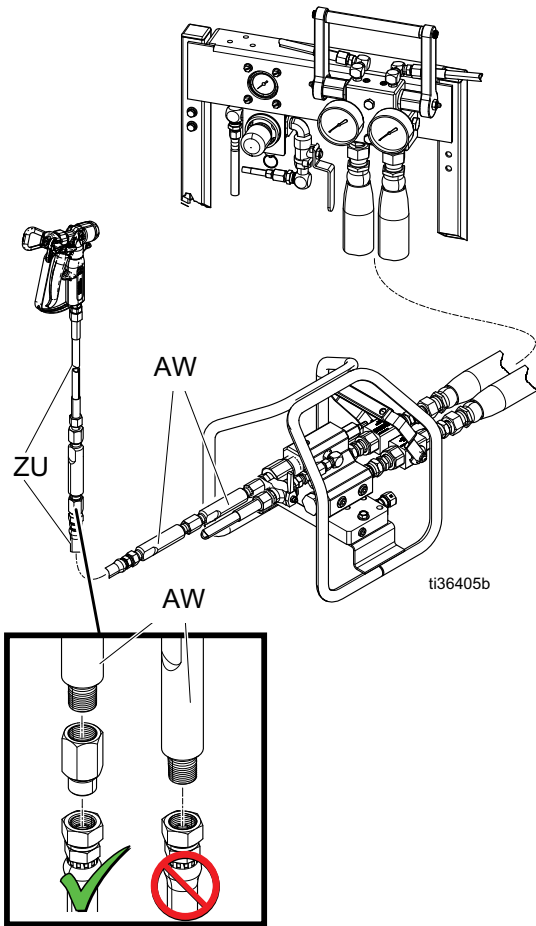

NOTICE

To prevent creating a flare on the mixer tube, do not use a union swivel end on the mix tube inlet.

Add Heating Fluid to Heated Hoppers



1. Use a 50/50 mixture of water and ethylene glycol (engine coolant) for heating fluid in the outer cavity of the hopper. Approximately 12 gallons (45 liters) of heating fluid is needed for each hopper.

NOTICE

Other glycols (RV/Marine Antifreeze) are not recommended for use as a heating fluid. These materials are not rated for higher temperatures and could cause damage to the immersion heaters.

NOTE: The ethylene glycol mixture provides the fastest heat-up time and prevention of algae build-up regardless of ambient temperature. Oil can be used but heat-up time will increase and the hopper level needs to be lower to allow for thermal expansion.

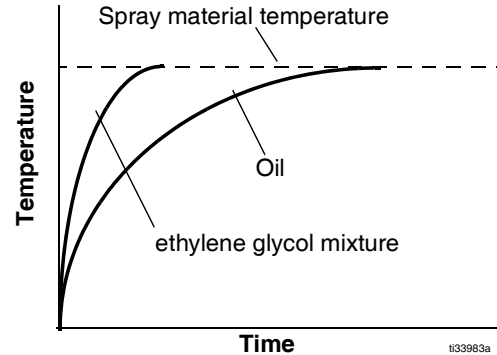

2. Remove fill port cap (ET) and pour heating fluid in the outer cavity through the fill port (EK).

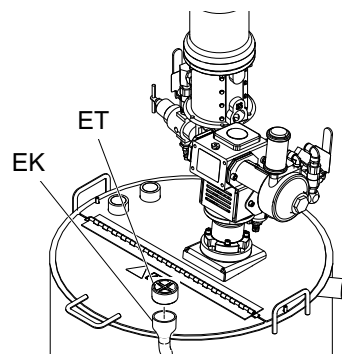

- 3. Use approximately 12 gallons (53 liters) to fill the cavity. Stop filling when fluid is visible at the bottom of the port elbow.

NOTE: Thermal expansion may cause the heating fluid to overflow after it rises to temperature.

NOTE: If using water mix, the maximum fluid level must be 1 in. (2.5 cm) below side port level.

NOTE: If oil is the heating fluid, the maximum oil level must be 3 in. (7.6 cm) below the hopper side port level.

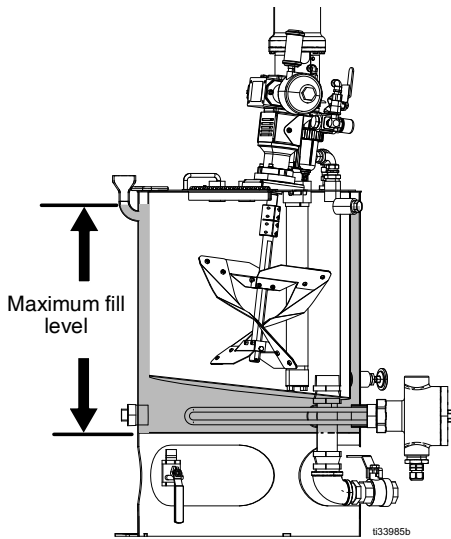

- 4. Replace the fill port cap (ET).

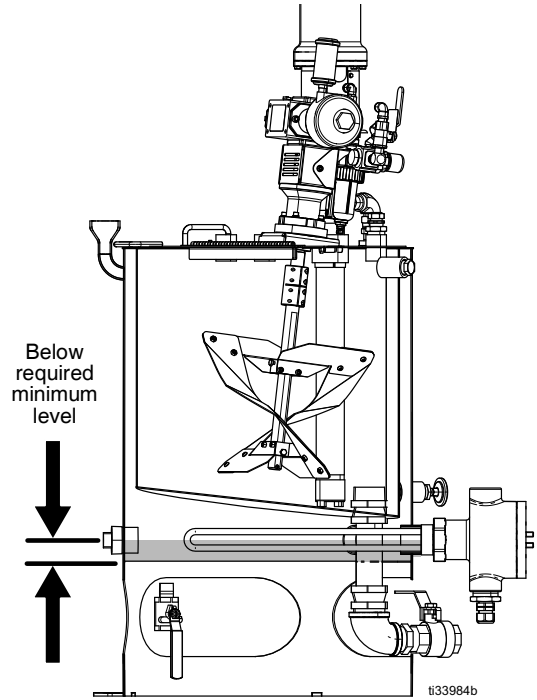

NOTICE
Any portion of the heating element exposed to air will lead to overheating and premature burnout. Ensure that the element is completely submerged.

Agitators (ED)

The Xtreme-Duty Agitator is provided with an airline lubricator to aid in proper maintenance. Fill the lubricator with Air Motor Oil 202659 (do not fill past the maximum level shown in the oil fill sight glass). Set the lubricator feed rate at one drop of oil per minute. Do not overfeed the oil, or the exhaust air may become contaminated.

Adjusting Knob

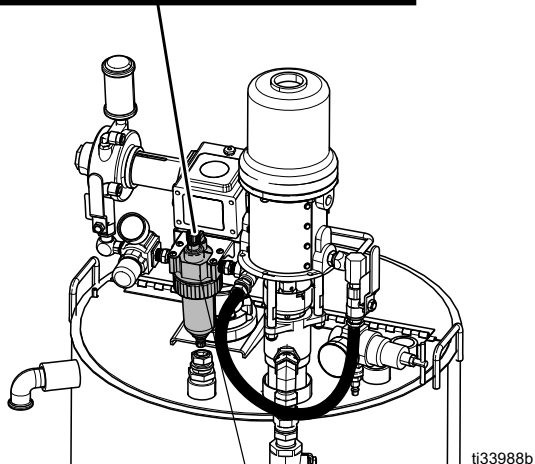
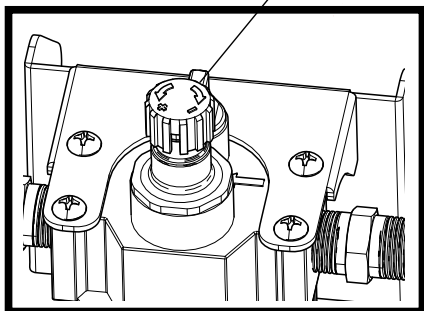

Fill Port

Oil Fill Sight Glass

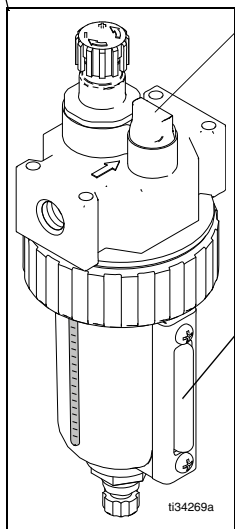

Feed Pumps (EE)

Fill the wet-cup half full with Graco Throat Seal (TSL™) or a compatible solvent.

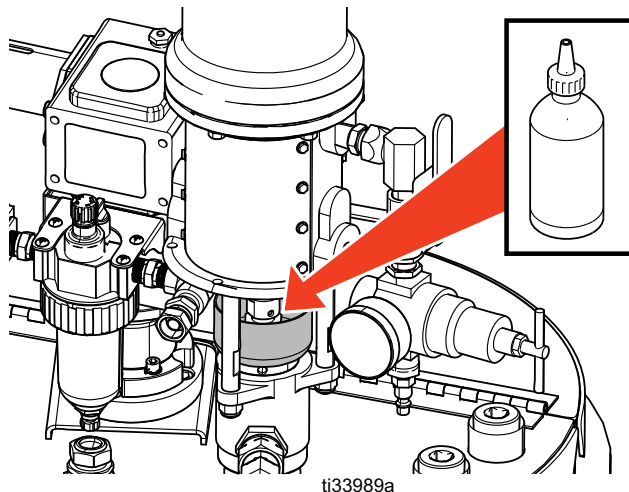

Solvent Pump (BA)

Before starting, fill wet cup (BH) 1/3 full with Graco Throat Seal Liquid (TSL) or compatible solvent.

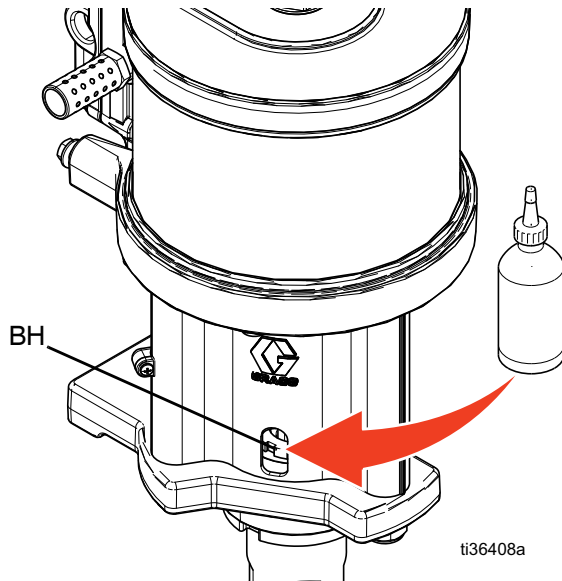

XP Displacement Pumps (D)

Make sure the A and B pump packing nuts are tightened. Fill the A and B pump packing nuts with TSL.

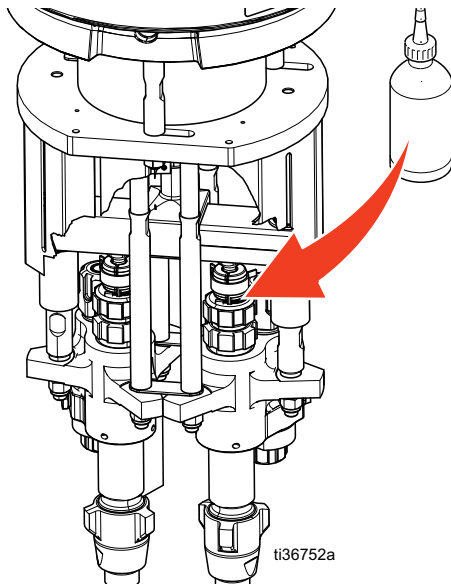

Add Heating Fluid to Hoses

(Water jacket heated hose packages only)

1. Add a 50/50 mixture of water and ethylene glycol to the reservoir (ZF) of the diaphragm pump (ZG).
2. Slowly open the needle valve (ZP) to circulate the fluid with the diaphragm pump (ZG) to remove air from the system.
3. Continue adding heating fluid to the reservoir (ZF) as air continues to bleed from the system.
4. Stop the pump when there is no more air in the system, fill the reservoir (ZF) halfway, then replace the cap.

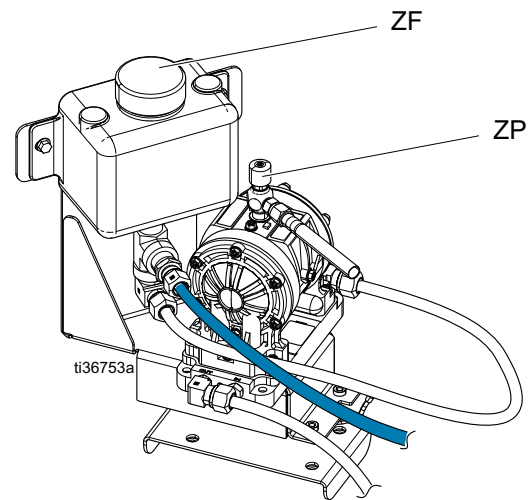

Operation

Flush Before Using Equipment

The system was tested with lightweight oil, which is left in the fluid passages to protect parts. To avoid contaminating your fluid with oil, first flush the equipment with a compatible solvent before using the equipment. Follow the **Flushing** procedure, page 44.

Prime the Empty System

To help prevent injury from burns, wear gloves when using solvents and/or if the fluid temperature exceeds 122 °F (50 °C).

1. Prepare your materials prior to adding to heated hoppers. Ensure resin materials are thoroughly agitated, homogeneous, and pourable prior to adding them to the hopper. Stir hardeners back into suspension prior to adding material to the hopper.
2. Move the recirculation lines (U) to grounded empty containers.

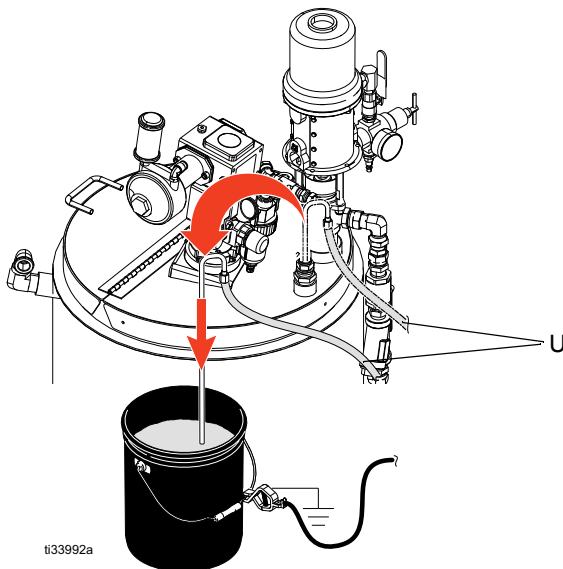

3. Fill the “A” and “B” hoppers (J) with respective material, up to 25 gallons. Fill the “A” side (blue) with resin or base material. Fill the “B” side (green) with the hardener or catalyst.

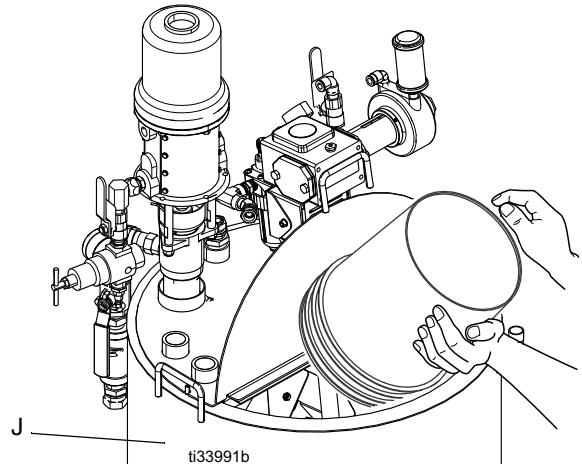

4. Open the main air valve.
5. Close the dual shutoff handle (AE).

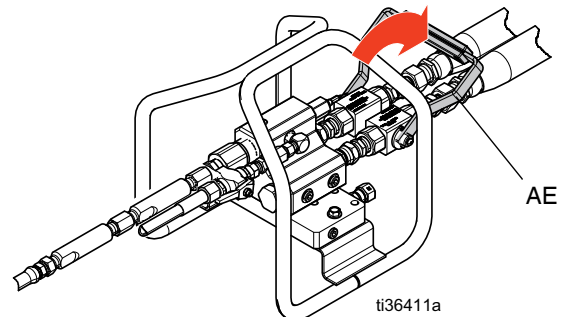

6. Open the recirculation handle (AC).

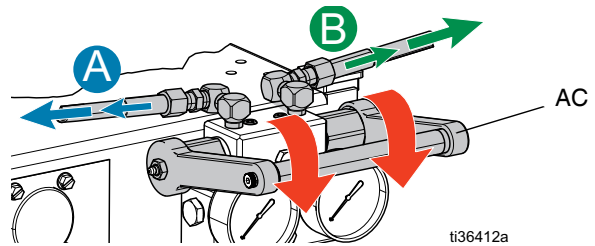

7. Fully open the feed pump air regulator (EN) and turn the feed pump air valve (EM) to OPEN.
8. Slowly open the feed pump air regulator (EN) to start the feed pump.

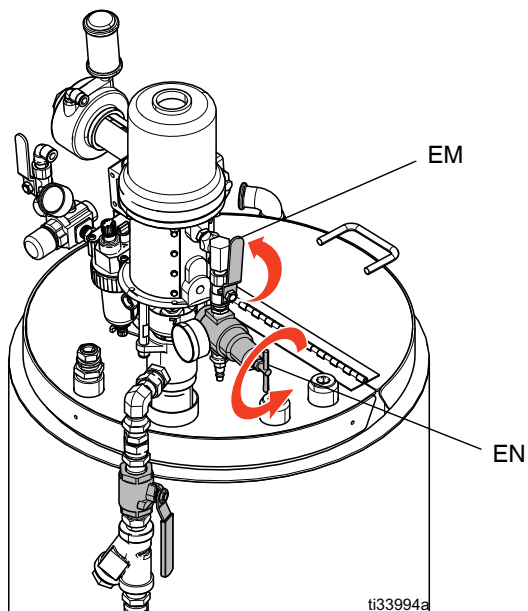

NOTE: If the material is too thick, the XP-hf pump will need to be used. See **Startup/Recirculate** on page 36.

9. Dispense fluid into the containers until clean fluid flows through the “A” and “B” recirculation lines.
10. Close the feed pump air regulator (EN).
11. Close the feed pump air valve (EM).

12. Move the recirculation lines (U) back to the correct hopper.

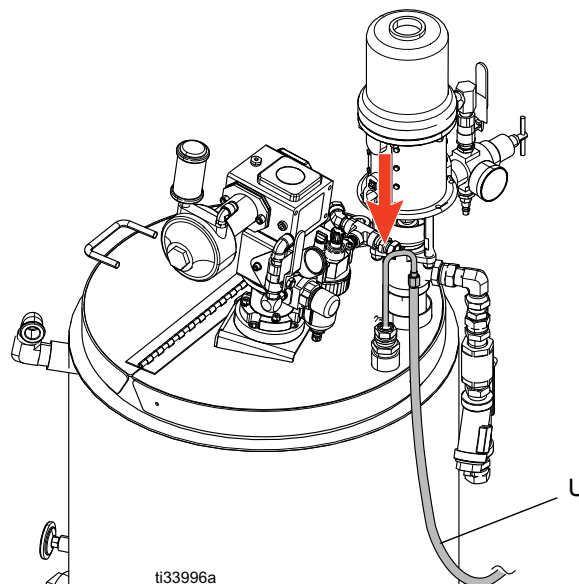

13. Repeat for the other side.
14. If running solvent through the system for the first time, proceed to **Flushing** on page 44 to empty the system of solvent, then repeat this process with “A” and “B” materials.

Startup/Recirculate



NOTE: Use recirculation mode to condition materials prior to spraying; agitating and heating materials evenly. The hopper heaters are factory set to maintain temperatures of conditioned materials only. To bring spray material up to temperature, the material needs to circulate through the HF heaters while adjusting the heater set point to the desired temperature.

1. Ensure that the main power switch (MP) is ON at the junction box.

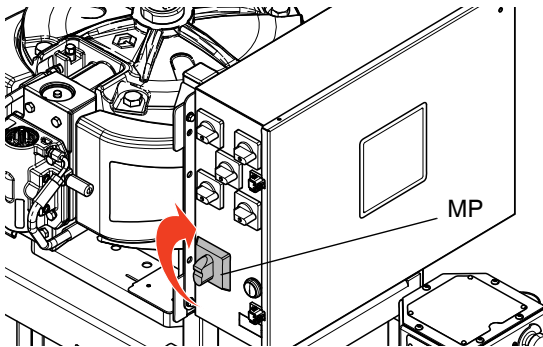

2. Turn on the hopper heat switches (ZN).

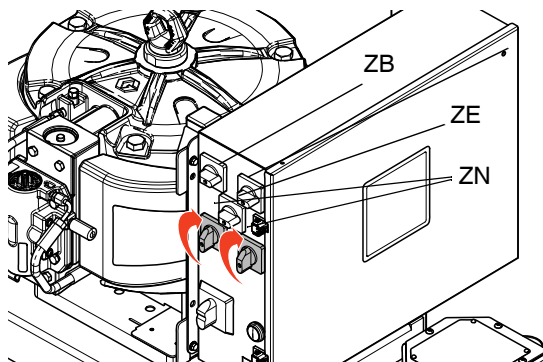

3. Ensure the agitator air regulator is fully closed and open the agitator air valve (EP) to the OPEN position.

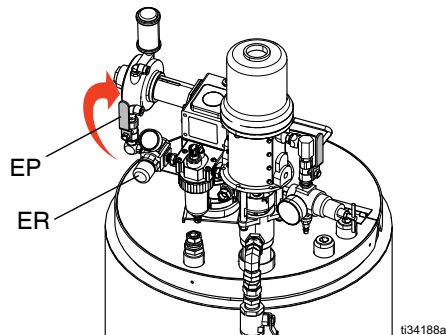

4. Slowly increase the agitator air regulator (ER) to turn the agitator until the desired speed is reached.
5. Ensure the feed pump air regulator (EN) is fully closed and open the feed pump air valve (EM) to the OPEN position.

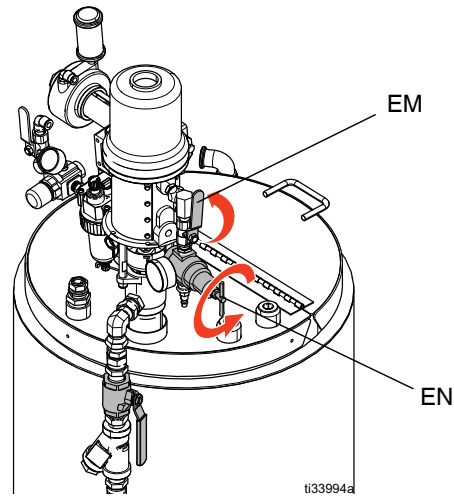

6. Slowly open the feed pump air regulator (EN) until the pump starts. Cycle the feed pump slowly until the feed pump stalls.
7. Repeat steps 3-6 for the other heated hopper.
8. Open the recirculation valve handle (AC).

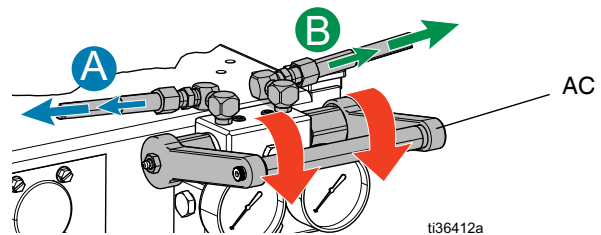

9. Fully open the XP-hf air pressure regulator (CB) then turn the air valve (CA) to OPEN. Use the XP-hf air pressure regulator (CB) to slowly increase the air pressure until the XP-hf pumps start running slowly.
10. Turn on the primary heater switches (ZB). To adjust the heater temperature, refer to your Viscon heater manual for instructions.
11. Recirculate the fluids to raise the temperature of the materials in the hoppers evenly. Continue running the pump until the material is uniform and reached the desired temperature.

NOTE: Begin circulating the XP-hf pump to run at approximately 10 cycles/min to evenly heat materials, increase or decrease the pump rate depending on material conditions.

12. **For systems with water-heated hose:** Pump setting - Set the flow rate of the heating fluid by opening the diaphragm pump (ZG) needle valve (ZP) 45°- 60° open until the pump cycles 60-80 cycles/min (0.7-1.0 gpm or 2.6-3.8 l/min).

13. **For systems with water-heated hose only:** Heater setting - Adjust the heater thermostat to the desired temperature. The setting at the heater output thermometer should be approximately 10 °F (6 °C) higher than the desired paint temperature. Never exceed the XP system 160 °F (71 °C) maximum fluid temperature rating. See your Viscon HP heater manual for instructions.

As a general guideline, heater knob settings are #7 for 105 °F (40 °C), #8 for 135 °F (57 °C), and #8 1/2 for 150 °F (65 °C).

NOTE: If the hose heat is not being used for more than one hour, shut off the hot water heater (ZT) and diaphragm pump (ZG) to lengthen heater life.

14. On initial start-up, proceed to **Flushing** on page 44.

Prime Solvent Pump



1. Connect a ground wire (not included) to a metal pail of solvent.
2. Place the siphon tube (BB) and the solvent circulation hose (BG) in the pail of solvent.

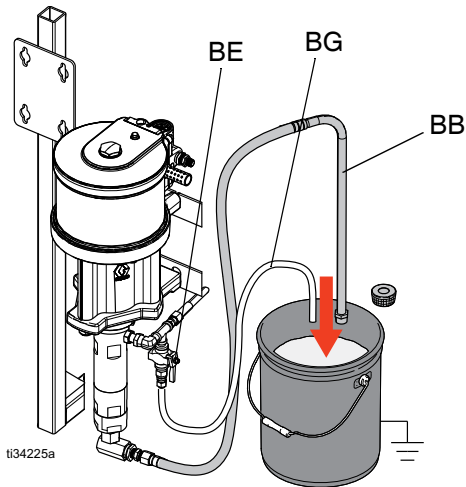

3. Open the solvent prime valve (BE).
4. Open the solvent pump air valve (DA). Slowly turn the solvent pump air regulator (DB) clockwise to prime the solvent pump and route solvent back to the pail. Close the solvent prime valve (BE) and air valve (DA).

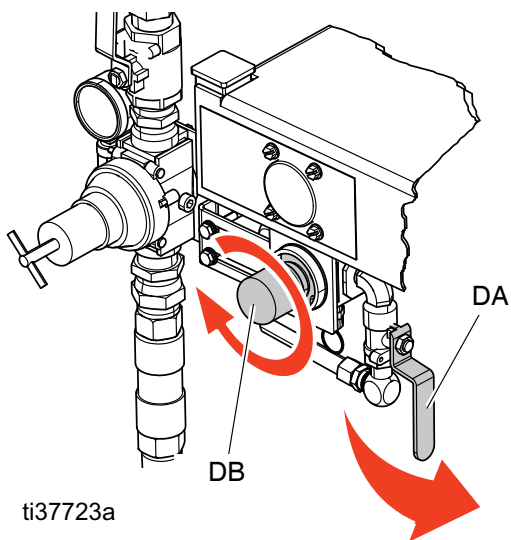

5. Open the solvent flush valve (AD) on the mix manifold.

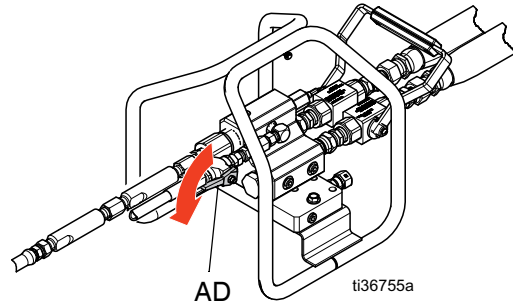

6. Ensure the trigger lock (TL) is engaged. Remove the spray tip.

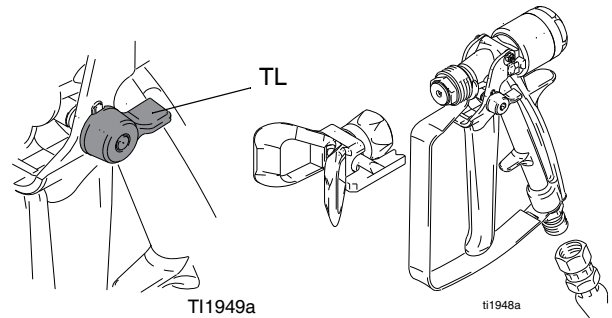

7. Disengage the trigger lock (TL) and trigger the gun into a grounded metal pail while holding the metal part of the gun firmly against the side of the pail. Use a pail lid with a hole to dispense through. Seal around the hole and gun with a rag to prevent splash back. Be careful to keep fingers away from the front of the gun.

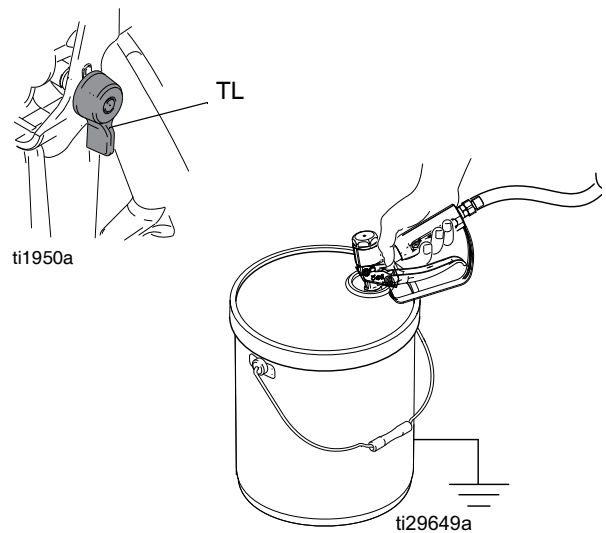

8. Slowly turn the solvent pump air regulator (DB) clockwise to prime the solvent pump and push air out of the mix hose and gun. Continue to hold the metal part of the gun firmly against the side of the grounded metal pail and trigger the gun until all air is purged.

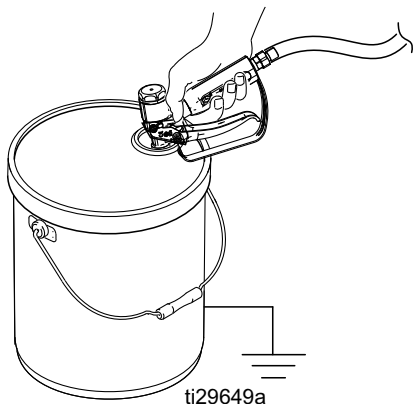

9. Close the solvent pump air valve (DA) and trigger the gun to relieve pressure. Engage the trigger lock (TL). Replace the spray tip.

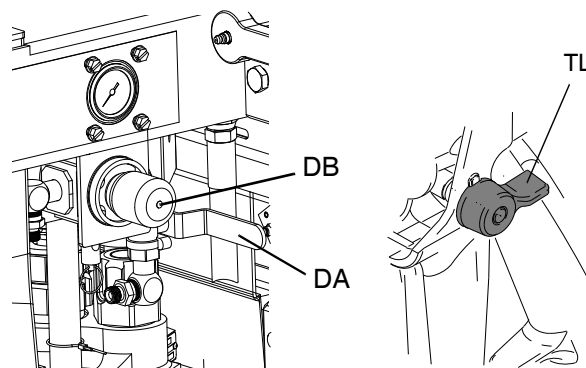

10. Close the solvent flush valve (AD).

NOTE: Solvent pump may stay pressurized while spraying.

NOTICE

To prevent material from curing inside the system, never spray mixed material without the solvent pump and hose primed with solvent for proper flushing in time to clear the mixed material.

Prime the Material Lines

(Units with heated hose and remote mix manifold)

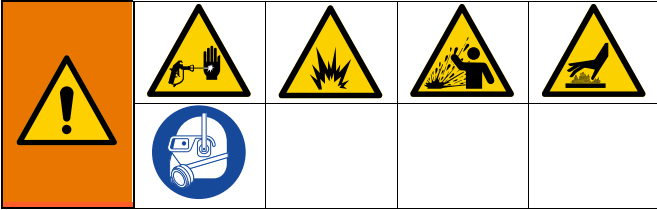

1. Follow the **Prime the Empty System** procedure on page 34.
2. Follow the **Startup/Recirculate** procedure on page 36.
3. Close the recirculation handle (AC).

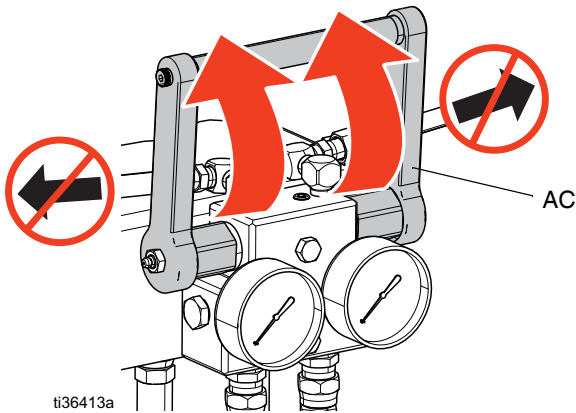

4. Open the dual shutoff handles (AE).

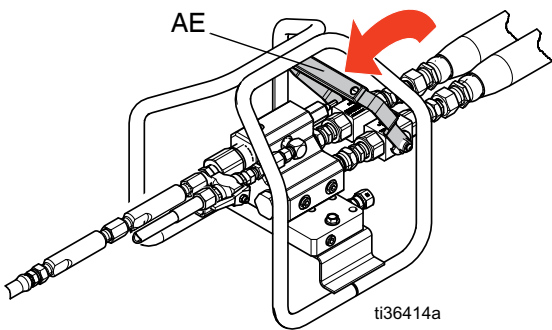

5. Engage the trigger lock (TL). Remove the spray tip.

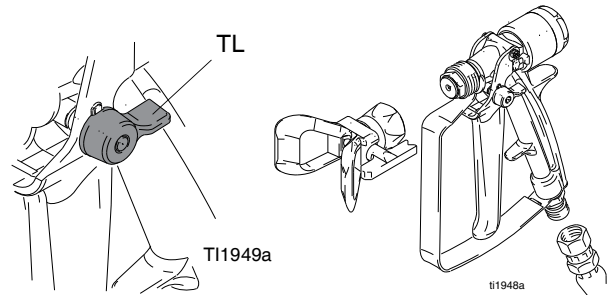

6. Slowly increase the XP-hf motor air regulator (CB) enough to cycle the pumps.
7. Disengage the trigger lock (TL) and trigger the gun into a grounded metal pail while holding the metal part of the gun firmly against the side of the pail. Use a pail lid with a hole to dispense through. Seal around the hole and gun with a rag to prevent splash-back. Keep fingers away from the front of the gun.

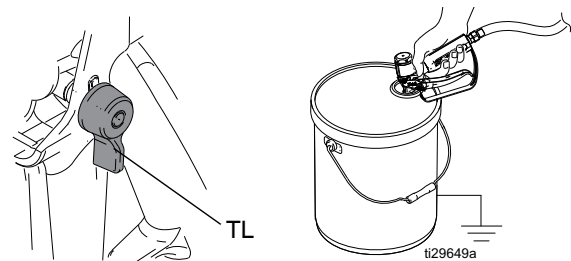

8. Close the XP-hf motor air valve (CA).

Spray

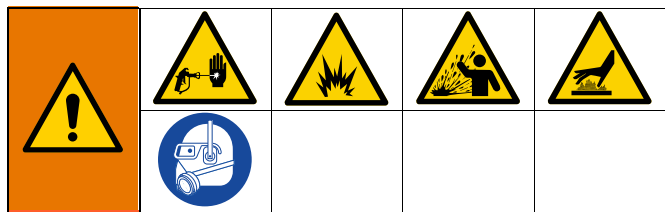

1. Follow the **Startup/Recirculate** procedure on page 36.
2. Ensure that the XP-hf air pressure regulator (CB) and is fully closed and open the XP-hf air valve (CA).

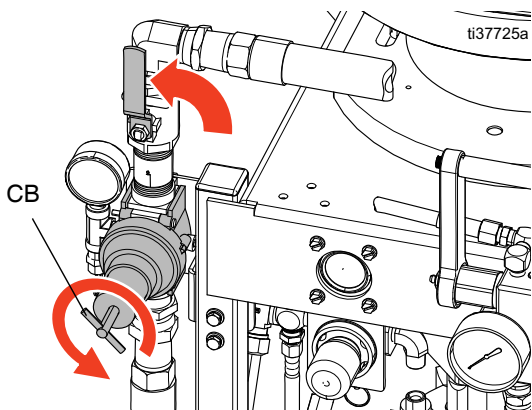

3. Close the recirculation handle (AC) and the solvent flush valve (AD). Open the dual shutoff handle (AE).

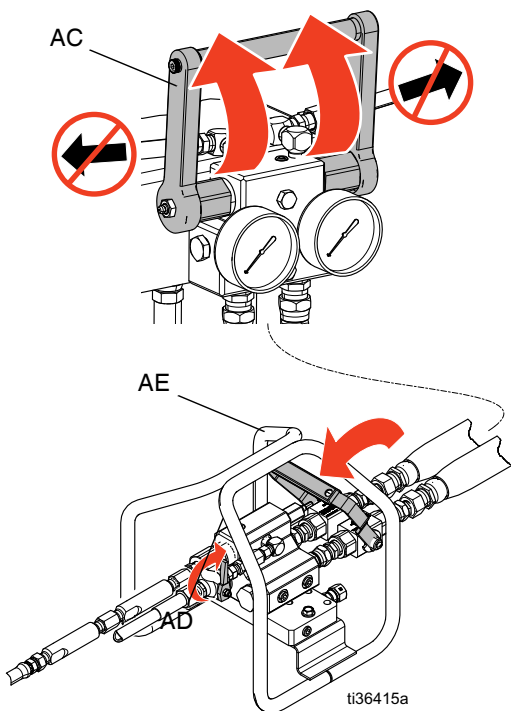

4. Slowly increase the XP-hf air regulator (CB) to cycle the pumps.

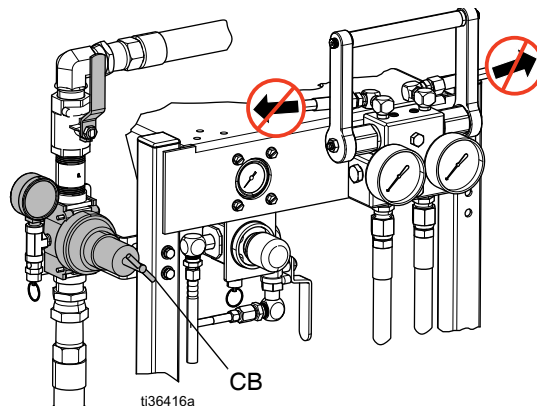

5. Engage the trigger lock (TL). Remove the spray tip.

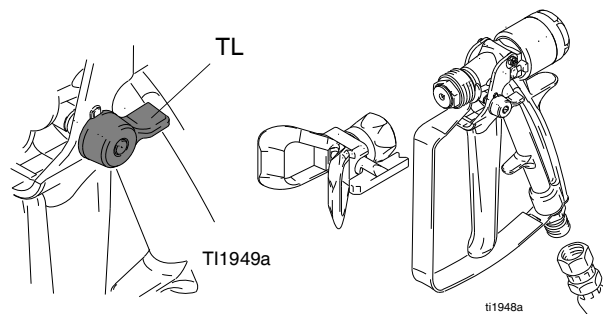

6. Disengage the trigger lock (TL) and trigger the gun while holding against a grounded metal pail. Use a metal pail lid with a hole to dispense through to avoid splashing-back. Dispense out of the mix hose until a well mixed coating flows from the gun.

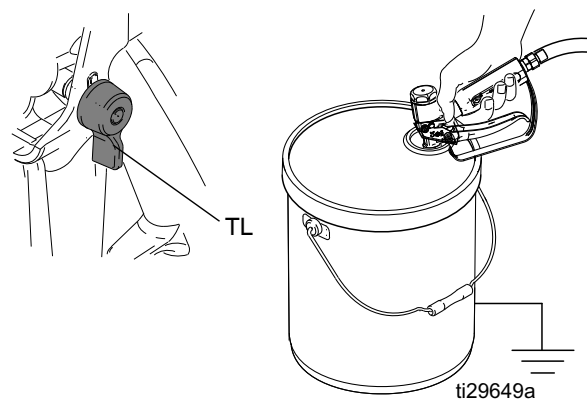

7. Engage the trigger lock (TL). install the tip on the gun.

- Adjust the XP-hf motor air regulator (CB) to the necessary spraying pressure and apply a coating to a test panel.

NOTE: Run **System Verification** tests everyday (see page 49).

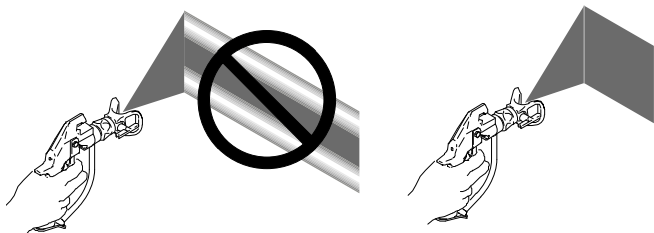

NOTE: Excess pressure increases overspray and pump wear.

- Check and record gauge readings frequently during operation. A change in gauge readings indicates a change in system performance.

NOTE: A pressure drop occurs during pump stroke changeover. It should be quick and synchronous.

- Flush the mix manifold as necessary during the day's operation. Follow the **Flush Mixed Material** on see page 44.

- Follow the **Flushing** procedure on page 44. when you are finished spraying or before potlife expires.

NOTE: Mixed material potlife or working time decreases with increased temperature. Pot life in the hose is much shorter than the dry time of the coating

Adjust the Restrictor

The B side restrictor (AJ) reduces momentary “lead/lag” ratio imbalance of the A and B flow into the static mixer tubes (AN, AW) when the gun opens. The error is caused by differences in viscosity, volume, and hose expansion.

The restrictor is used primarily when the mix manifold is positioned remotely from the machine with a short mix hose to the spray gun. It can also be used in the ratio check procedure.

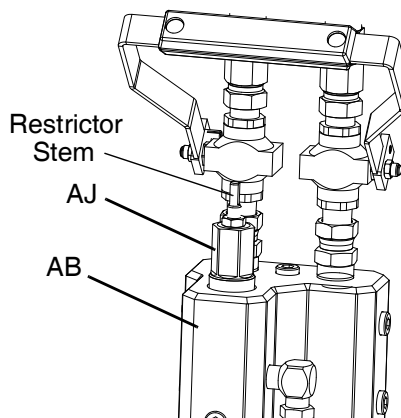

If the mix manifold (AB) is mounted on the machine, you do not need to adjust the restrictor. Leave the restrictor stem open two turns minimum from fully closed.

Use the wrench restrictor (92) to balance the “B” pressure to the “A” pressure. Turn the restrictor clockwise to increase pressure, or counterclockwise to decrease pressure.

Pressure Relief Procedure



Follow the Pressure Relief Procedure whenever you see this symbol.

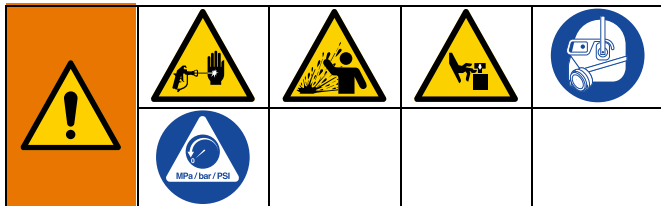

This equipment stays pressurized until pressure is manually relieved. To help prevent serious injury from pressurized fluid, such as skin injection, splashing fluid and moving parts, follow the Pressure Relief Procedure when you stop spraying and before cleaning, checking, or servicing the equipment.

1. Close the XP-hf motor air valve (CA).

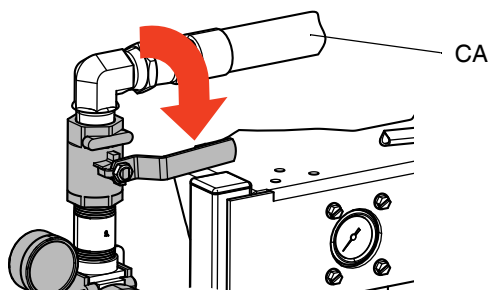

2. Hold a metal part of the gun firmly to a grounded metal pail. Trigger the gun to relieve pressure in material hoses.

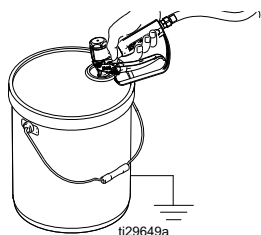

3. Engage the trigger lock (TL), then remove the spray tip.

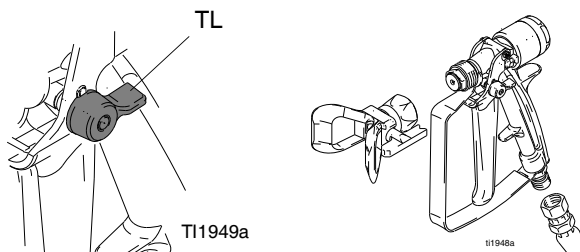

4. Close the dual shutoff handle (AE).

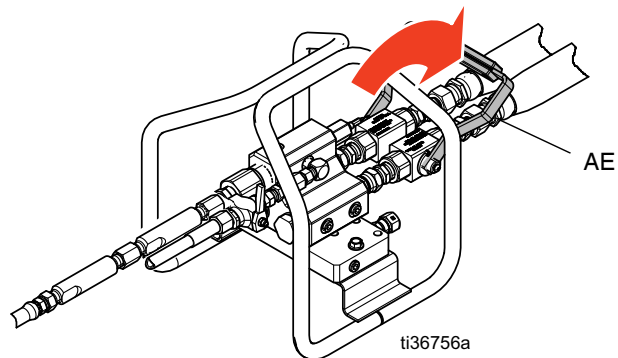

5. Open the recirculation handle (AC) to relieve "A" and "B" fluid pressure.

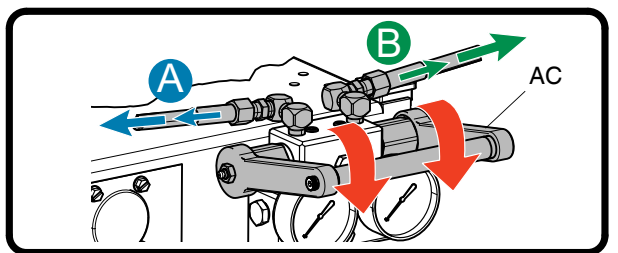

6. Close both feed pump air valves (EM).

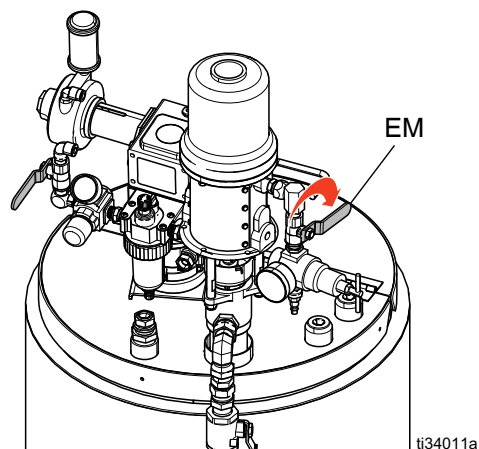

Flushing

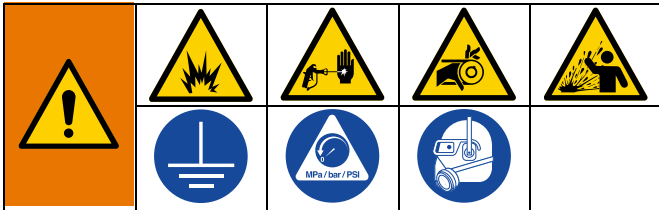

To avoid fire and explosion, always ground equipment and waste container. To avoid static sparking and injury from splashing, always flush at the lowest possible pressure. Hot solvent may ignite. To avoid fire and explosion:

- Flush equipment only in a well-ventilated area
- Ensure main power is off and heater is cool before flushing
- Do not turn on heater until fluid lines are clear of solvent

Guidelines

Flushing will help prevent materials from setting or gelling in the pumps, lines, and valves. Flush the system when any of the following situations occur:

- Any time the system will not be used for more than one week (depending on materials used)
- If the materials used have fillers that will settle
- If using materials that are moisture sensitive
- Before servicing
- If the machine is going into storage, replace the solvent with light oil. Never leave the equipment empty of any fluid.

Flush the mix manifold when any of the following situations occur:

- Breaks in spraying
- Overnight shutdown

Mixed material in system approaching end of pot life

Flush Mixed Material

1. Follow the **Pressure Relief Procedure** on page 43.
2. Ensure the solvent pump regulator (DB) is fully closed and open the solvent air valve (DA).

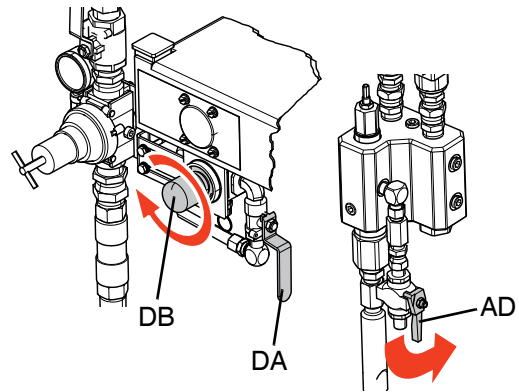

3. Open the solvent flush valve (AD).
4. Disengage the trigger lock (TL), hold the gun against a grounded metal pail, and trigger the gun into the pail. Use a pail lid with a hole to dispense through. Seal around the hole and gun with a rag to prevent splash back. Be careful to keep fingers away from the front of the gun. Continue flushing until clean solvent dispenses.

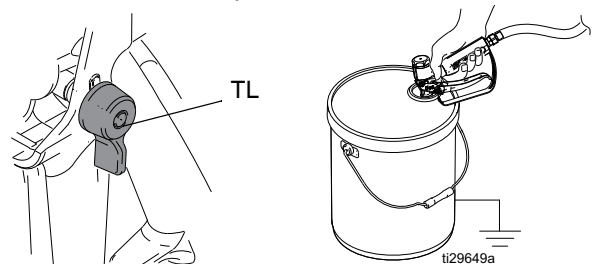

5. Close the solvent pump air valve (DA).
6. Hold a metal part of the gun against a grounded metal pail and trigger the gun to relieve pressure. Close the solvent flush valve (AD) after relieving the pressure.
7. Engage the trigger lock (TL). Disassemble and clean the spray tip with solvent by hand. Reinstall spray tip on the gun.

Flush Hoppers Procedure

1. Follow the **Flush Mixed Material** procedure on page 44.
2. Turn off all heater switches (ZB, ZE, ZN) and the main power switch (MP). Allow the system to cool before flushing.

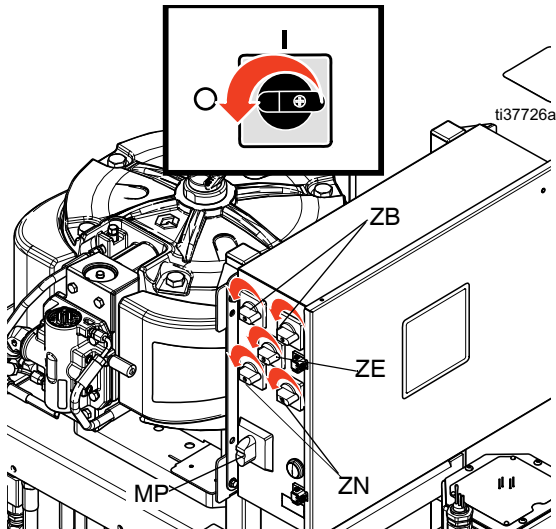

3. Engage the trigger lock (TL).

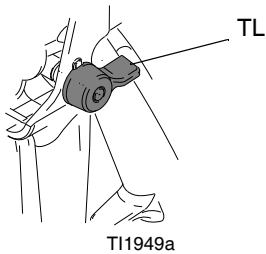

4. Turn the XP-hf motor air pressure regulator (CB) fully counter-clockwise to shut off.

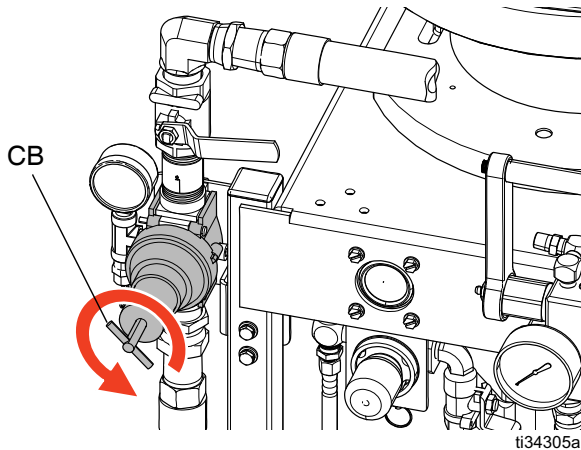

5. Open the recirculation handle (AC).

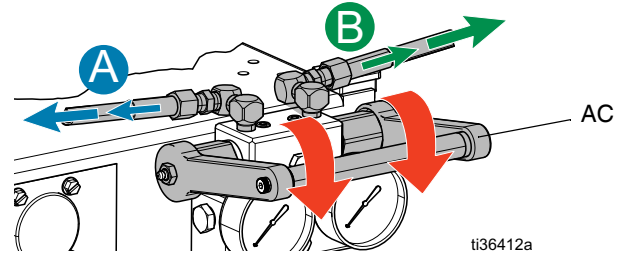

6. Move the recirculation lines (U) to separate grounded fluid containers and pump remaining spray material out of the system.

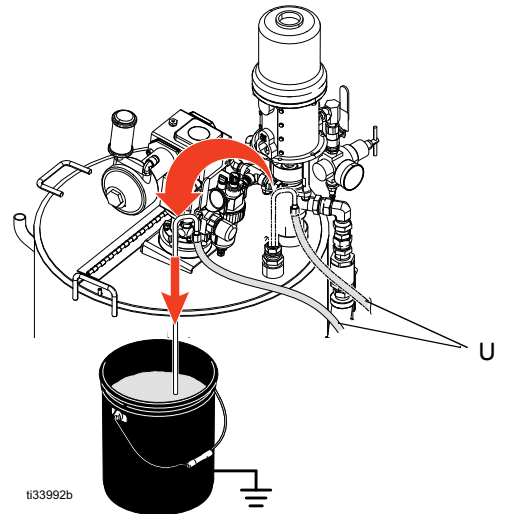

7. Open the feed pump air valve (EM) and pump material out of the hopper.

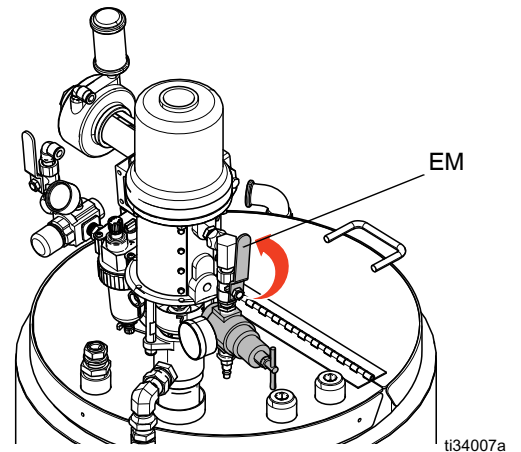

Operation

- Run the feed pumps until they are dry. Turn off the feed pump air valve (EM) and agitator air valve (EP).

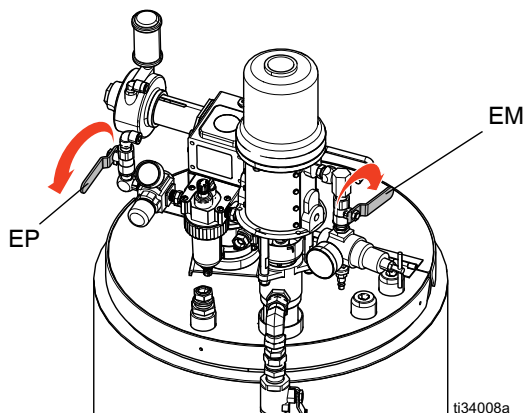

- Place a small pail under the hopper and open the material drain (EH) to fully drain the spray material.

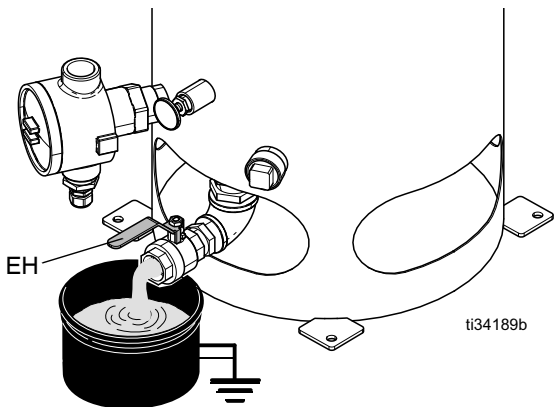

- Close the material drain (EH) and fill the hopper with solvent.

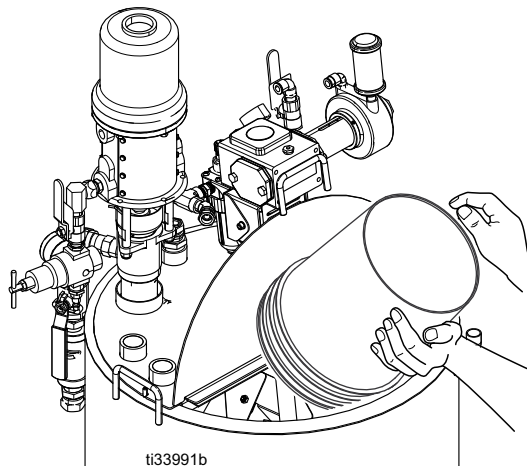

- Return the recirculation lines (U) to their respective hoppers.
- Open on the agitator air valve (EP) and pump air valve (EM). Circulate for two to three minutes.

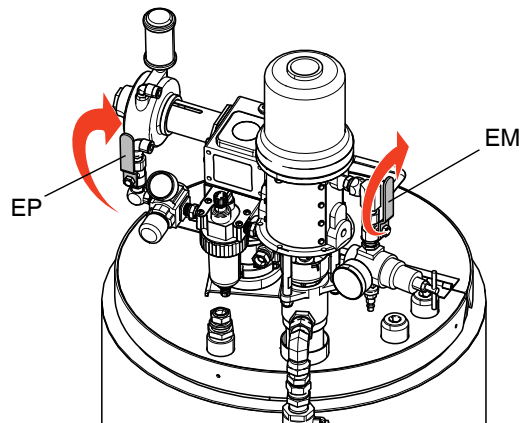

- Repeat steps 4 - 10. Change the flushing solvent until it runs clean. To flush the remainder of the system, follow **Flush Material Lines Procedure** on page 47.

Flush Material Lines Procedure

1. Follow the **Flush Mixed Material** procedure on page 44.
2. Follow the **Flush Hoppers Procedure** on page 45.
3. Close the recirculation handle (AC) and open the dual shutoff handle (AE).

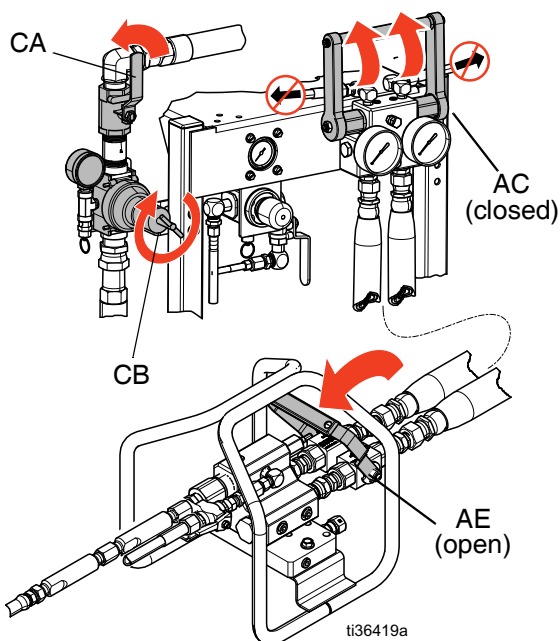

4. Open the XP-hf motor air shutoff valve (CA) and increase the XP-hf motor air pressure regulator (CB) to dispense fresh solvent from the hoppers through the mix manifold valves and out the gun.
5. Continue flushing solvent until it runs clean.
6. Close the motor air shutoff valve (CA).
7. Lift to close the dual shutoff handle (AE).

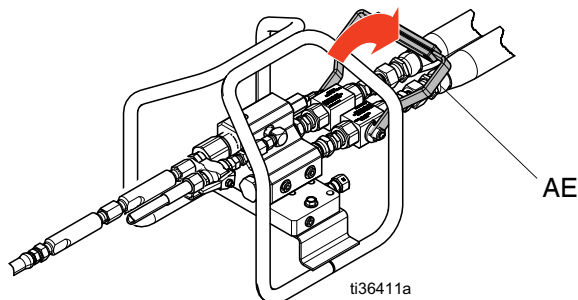

8. Close the main inlet air shutoff valve (CF).

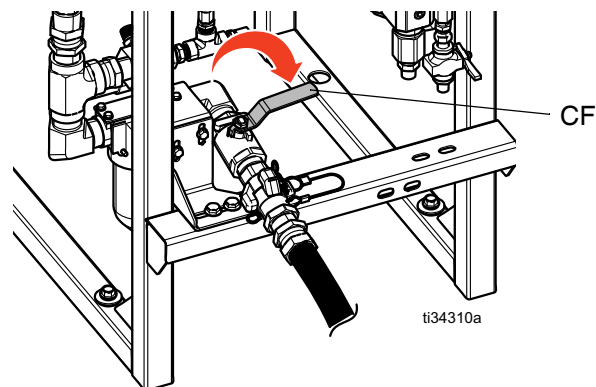

9. Remove the filters of the XP displacement pumps and soak in solvent. Clean and replace the filter cap. Always replace the filter o-rings. See your Xtreme lower pump manual.
10. Fill the pump packing nuts of the XP displacement pumps with TSL.

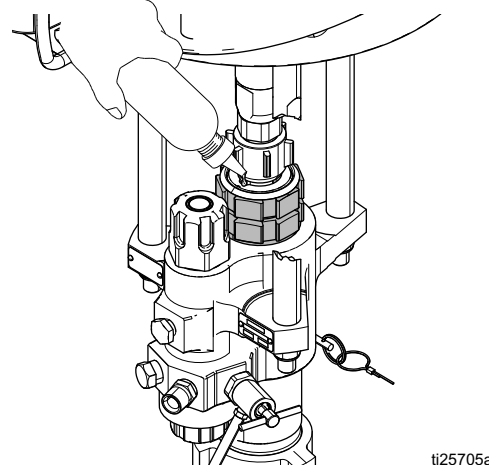

NOTICE

Always leave some type of fluid, such as solvent or oil, in the system to prevent scale build up. This build up can flake off later and cause damage to the equipment.

NOTE: Always keep the A side and B side solvent containers separate to avoid cross-contamination.

Overnight Shutdown



1. Follow the **Pressure Relief Procedure** procedure on page 43.
2. Flush the mix manifold, hoses, and gun. Follow the **Flush Mixed Material** procedure on page 44.
3. Open the recirculation handle (AC) and adjust the XP-hf motor air regulator (CB) so that the pump runs slowly.

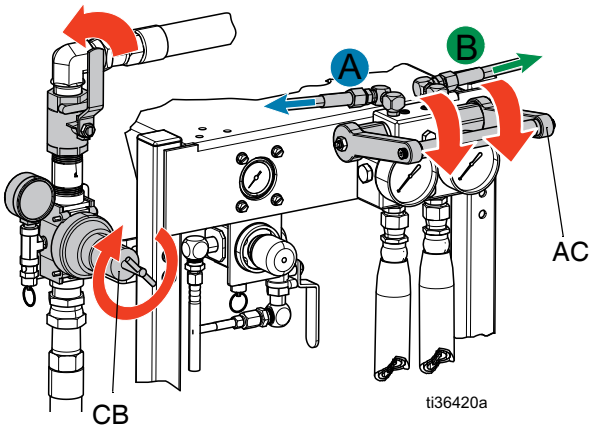

4. When the pump is at the bottom of the stroke, close the XP-hf motor air valve (CA) and turn the air regulator (CB).

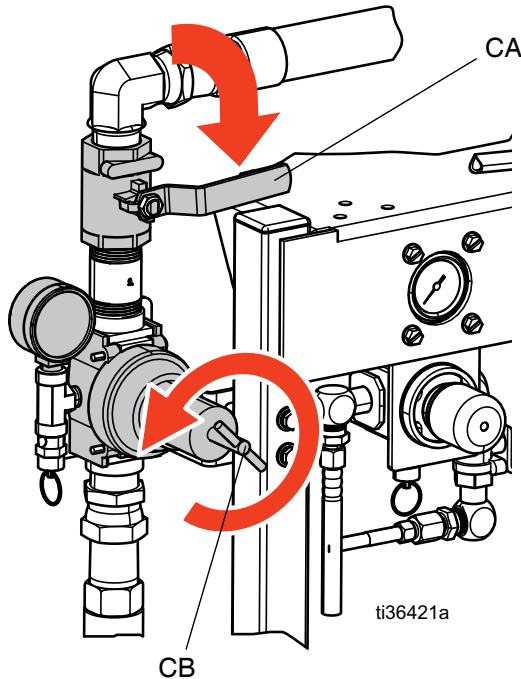

5. Turn off all heater switches (ZB, ZE, ZN) and the main power switch (MP).

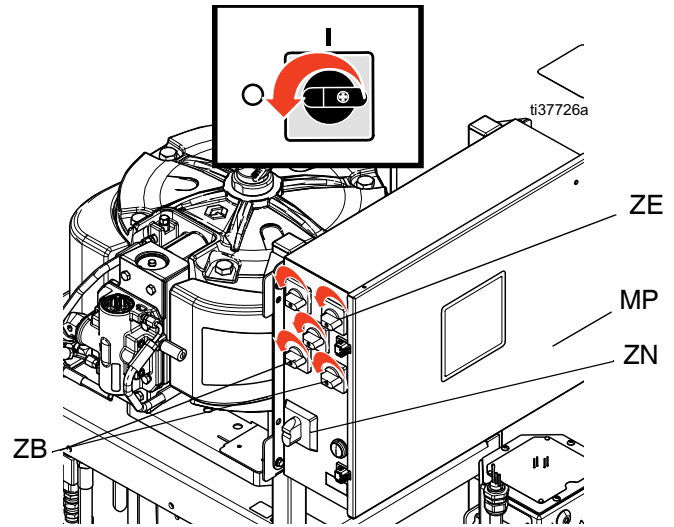

6. Close the feed pump air valve (EM) when the feed pump is at the bottom of the stroke.

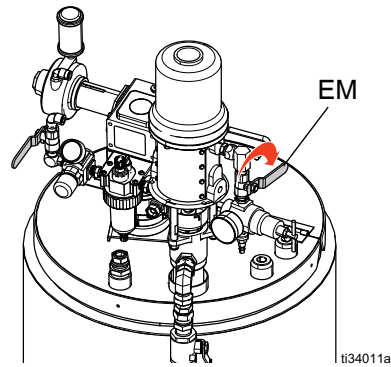

NOTICE

If fluid is allowed to dry on the exposed displacement rod, damage to the throat packings may occur. To prevent damage, always stop the feed pump at the bottom of the stroke.

7. Close the agitator air valve (EP).

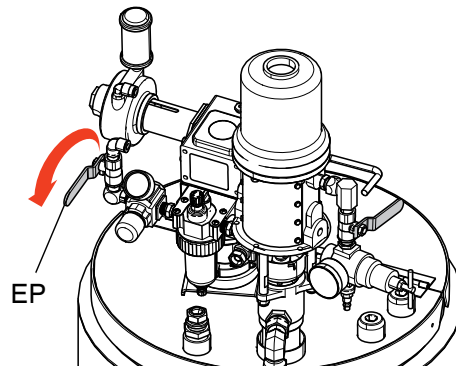

8. Turn off main air shutoff valve (CF).

System Verification

Graco recommends running the following tests daily.

Check for Normal Operation

Every time you start spraying:

- Watch the fluid gauges (AF). A pressure drop occurs during pump stroke changeover. It should be quick and synchronous.
- Stop the pumps on the upstroke. Check that both gauges hold pressure for at least 20 seconds.

If one gauge drops, the others will rise.

- Stop the pumps on the down stroke. Check that all gauges hold pressure.
- If using feed pumps, check that both feed pumps run during the proportioner upstroke.

Mix and Integration Tests



Use the following tests to check for proper mix and integration.

Butterfly Test

At low pressure, and with the spray tip reversed, dispense a 1/2 in. (12.7 mm) bead of material onto foil until multiple changeovers of each pump have occurred. Fold the sheet of foil over the fluid then peel it back and look for unmixed material (appears marble-like), or color changes.

Curing Test

Spray a single continuous pattern on foil at typical pressure setting, flow rate, and tip size until multiple changeovers of each pump have occurred. Trigger and de-trigger at typical intervals for the application. Do not overlap or cross over your spray pattern.

Check curing at various time intervals, listed on the material data sheet. For example, check for dry to touch by running your finger along the test pattern's entire length at the time listed on the data sheet.

Spots that take longer to cure indicate insufficient pump loading, leakage, or lead/lag errors at a remote mix manifold.

Appearance Test

Spray material onto foil. Look for variations in color, gloss, or texture that may indicate improperly catalyzed material.

Monitor Fluid Supply

NOTE: To prevent pumping air into the system, which causes incorrect proportioning, never allow the feed pump or solvent pump containers to run dry.

An empty pump will quickly accelerate to a high speed, and may damage itself and the other displacement pump because it causes a pressure rise in the other pump. If a supply container runs dry, stop the pump immediately, refill the container, and prime the system. Be sure to eliminate all air from the system.

Check Pot Life

Check the fluid manufacturer's instructions for fluid pot life at your fluid temperature. Flush mixed fluid out of the mix manifold, hose, and gun before pot life time expires, or before a rise in viscosity affects the spray pattern.

Ratio Check

Check the ratio at the mix manifold after any changes to the proportioning system. Use Ratio Check Kit 24F375 to check the ratio at the mix manifold. See manual ratio check kit manual for instructions and parts.

To prevent an inaccurate ratio check when feed pumps are used in your system, the feed pressure cannot be more than a maximum of 25% of the proportioner outlet pressure. High feed pressure can float the proportioner pump check balls, resulting in an inaccurate ratio check. There must be back pressure on both sides of the mix manifold when checking the ratio.

Maintenance

Hose Electrical Resistance

Check electrical resistance of hoses regularly. If total resistance to ground exceeds 29 megohms, replace hose immediately.

Filters

Once a week check, clean, and replace (if needed) the following filters.

- Both pump filters; see your Xtreme lower pump manual for instructions.
- Spray gun handle filter; see your spray gun manual.

Seals

Once a week, check and tighten throat seals on both pumps (see table for torque specifications). Follow the **Pressure Relief Procedure** procedure on page 43 prior to tightening seals. There must be zero pressure on the pumps when adjusting.

Pump Size	Torque Specification
All	25-30 ft-lb (34-41 N•m)

Cleaning Procedure

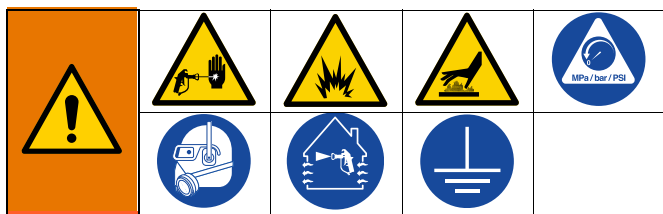

1. Ensure all equipment is grounded. See **Grounding**, page 24.
2. Ensure the area where the system will be cleaned is well ventilated and remove all ignition sources.

3. Turn off all heaters and allow equipment to cool.
4. Flush mixed material. Follow the complete **Flushing** procedure starting on page 44.
5. Follow the **Overnight Shutdown** procedure on page 48. Turn off all power.
6. Clean the external surfaces only using a rag soaked in solvent that is compatible with the spray material and surfaces being cleaned.
7. Allow enough time for the solvent to dry before using the system.

Change the Mix Ratio

In order to change the mix ratio, one or both pumps need to be replaced, the air motor needs to be re-positioned, and the over pressure relief valves may need to be changed.

1. Check the **Models** table on page 10 for the correct pump sizes.
2. Remove and replace pump. See **Remove XP Displacement Pump** page 56.
3. Adjust the position of the air motor. See **Recirculation Manifold with Over Pressure Relief Valves** page 57.
4. **If changing from one type of XPs-hf system to another (for example - changing from XP50s-hf to XP70s-hf or from XP70s-hf to XP50s-hf):** Remove the existing over pressure relief valves (702) and install the correct valves for the new system type. See **Replace Over Pressure Relief Valves** on page 58, and **Material Recirculation Manifold Replacement Table** on page 59.
5. Change the **XP-hf Motor Air Pressure Relief Valve (CG)** as required, depending on the ratio. See page 21.

Clean Inlet Strainer Screen



The inlet strainers filter out particles that can plug the pump inlet check valves. Inspect the screens daily as part of the startup routine, and clean as required.

1. Follow the **Startup/Recirculate** on page 36.
2. Ensure that all pumps are shut off and close the Y-strainer valve (ES).
3. Place a container under the strainer base to catch drain off when removing the strainer plug.
4. Remove the screen from the strainer manifold. Thoroughly flush the mesh screen (MS) with compatible solvent and shake it dry.

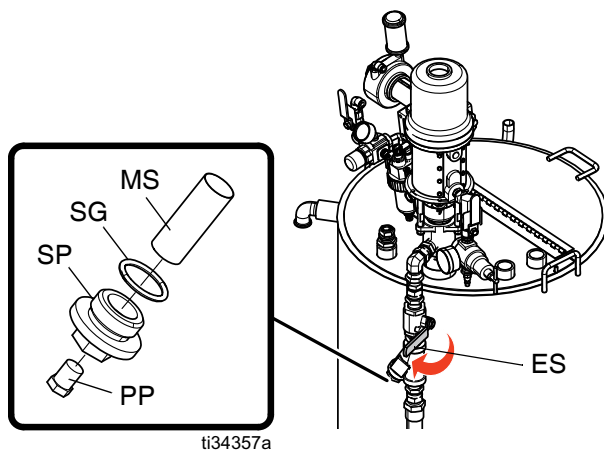

5. Inspect the screen. No more than 25% of the mesh should be restricted. If more than 25% of the mesh is blocked, replace the screen. Inspect the gasket and replace as needed. See your heated hopper manual for replacement components.
6. Ensure that the pipe plug (PP) is screwed into the strainer plug (SP). Install the strainer plug (SP) with the mesh screen (MS) and gasket (SG) in place and tighten. Do not over tighten the strainer plug--let the gasket make the seal.
7. Open the Y-strainer valve (ES). Ensure that there are no leaks and wipe the equipment clean.

Check Heating Fluid Level

Gradual fluid evaporation can occur. Check the level of heating fluid monthly. Add fluid as needed.

NOTICE

Freezing temperatures can cause damage that may result in the heating fluid leaking into the terminal enclosure. To avoid damage, do not expose the unit to freezing conditions.

Drain Heating Fluid

Replace heating fluid once a year to improve heating efficiency and increase heater element life. Keep the heating element above the sediment deposits. Sediment deposits will drain out from the coolant drain valve (EJ).

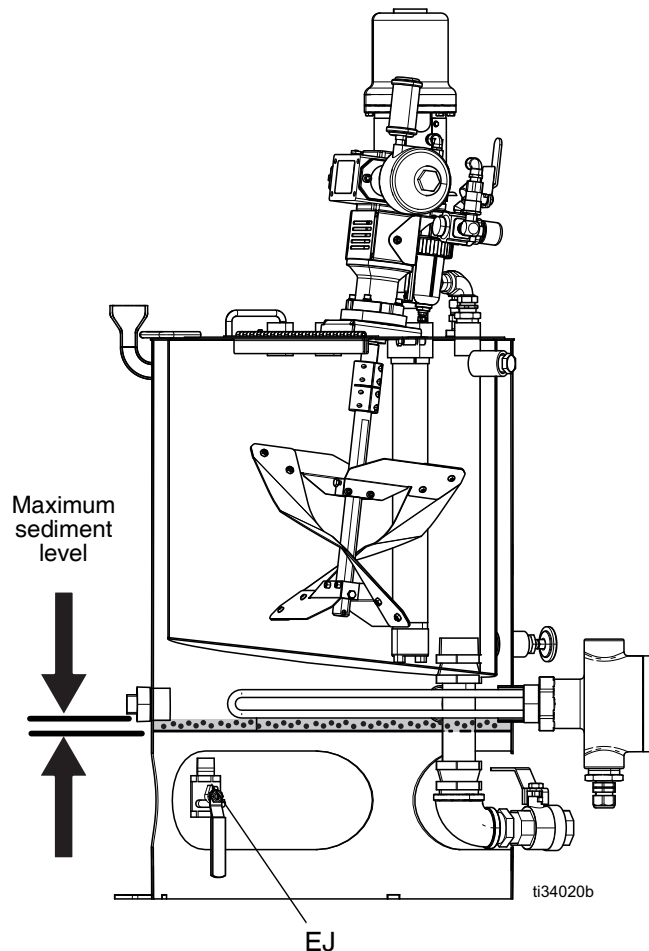

NOTE: The heater will not operate in sediment deposits.

Feed Pumps



Keep the packing nut/wet-cup half filled with Graco Throat Seal Liquid (TSL™) or compatible solvent to help prolong packing life.

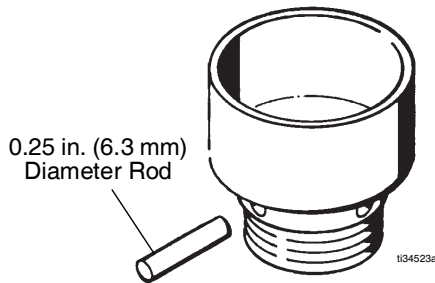

Adjust the packing nut weekly so it is just tight enough to prevent leakage. Use a spanner wrench or a 0.25 in. (6.3 mm) diameter rod to tighten the nut. Do not over-tighten.

Never leave the pump or hoses filled with water or air. To help prevent corrosion, flush the water and all air out of the system and leave it filled with mineral spirits or an oil-based solvent.

Solvent Pump

Keep the wet cup half filled with Graco Throat Seal Liquid (TSL™).

XP Displacement Pumps

Check packing nut. Torque to 25-30 ft-lb (34-41 N•m).

Keep the wet cup half filled with Graco Throat Seal Liquid (TSL™).

Agitators

NOTICE

To prevent air motor failure and possible damage to equipment, always keep the air motor properly lubricated using Air Motor Lubricant.

After the first 100 hours, or two weeks of operation, change the gear reducer oil. After that, change the oil every 2500 hours, or six months (whichever comes first) of operation under normal conditions. More frequent oil changes are needed under severe operating conditions or in atmospheres containing excessive moisture or abrasives. See your agitator manual for the oil changing procedure.

If the air motor is operating sluggish or inefficiently, flush the air motor (see your agitator manual).

Every 2500 hours, or six months (whichever comes first) of operation, inspect the bearing block (see your agitator manual).

Troubleshooting

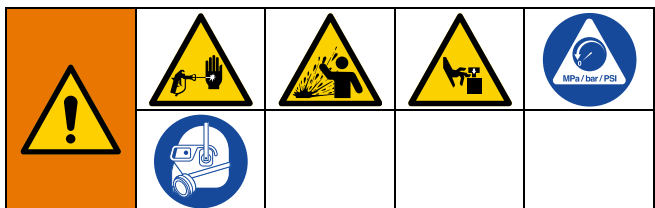

1. Follow **Pressure Relief Procedure** on page 43 before checking or repairing the system.
2. Check all possible problems and causes before disassembling the gun.

Problem	Cause	Solution
System stops or will not start.	Air pressure or volume too low.	Increase; check air compressor.
	Closed or restricted air line or air valve.	Open or clean.
	Fluid valves closed.	Open.
	Clogged fluid hose.	Replace.
	Air motor worn or damaged.	Repair air motor; see your air motor manual.
	Displacement pump stuck.	Repair pump; see your Xtreme pump manual.
System speeds up or runs erratically.	Fluid containers are empty.◆	Check often; keep filled.
	Air in fluid lines.◆	Purge; check connections.
	Displacement pump parts worn or damaged.	Repair pump; see your Xtreme pump manual.
Pump operates, but resin output pressure drops on upstroke.✘	Dirty, worn, or damaged resin pump piston valve or piston packings.	Clean, repair pump; see your Xtreme pump manual.
Pump operates, but resin output pressure drops on downstroke.	Dirty, worn, or damaged resin pump intake valve.	Clean, repair pump; see your Xtreme pump manual.
Pump operates, but resin output pressure drops on both strokes.✘	Hardener output restriction.	Clean, unplug hardener side. Open manifold restrictor.
	Fluid supply low.◆	Refill or change container.
Pump operates, but hardener output pressure drops on upstroke.✘	Dirty, worn, or damaged hardener pump piston valve or piston packings.	Clean, repair pump; see your Xtreme pump manual.
Pump operates, but hardener output pressure drops on downstroke.✘	Dirty, worn, or damaged hardener pump intake valve.	Clean, repair pump; see your Xtreme pump manual.
Pump operates, but hardener output pressure drops on both strokes.	Resin output restriction.	Clean, unplug resin side.
	Fluid supply low.◆	Refill or change container.
Fluid leak in packing nut.	Loose packing nut or worn throat packings.	Tighten; replace; see your Xtreme pump manual.
Fluid leak under packing nut	Packing cartridge o-ring.	Replace o-ring; see your Xtreme pump manual.
Relief valve (AM) leaks back to supply, opens too soon, or will not close.	Relief valve is dirty or damaged.	Replace over pressure relief valve (302)

Problem	Cause	Solution
No pressure on hardener side; fluid leaking from hardener pump outlet rupture disk fitting.	Overpressure rupture disk blown.	Determine cause of overpressurization and correct. Replace rupture disk assembly 258962 (see page 15) and over pressure relief valve (302).
Pressure and flow surges on upstroke.	Feed pressure too high. Every 1 psi of feed pressure adds 2 psi during upstroke.	Reduce feed pressure. See Repair , page 56.
Fluid outlet pressure gauges split only at the top changeover (if one gauge drops the other will rise).	Not fully loading one side on upstroke.	Increase feed pressure on side that dropped. Increase feed hose size. Clean inlet strainer or hopper screen.
	Air mixed in fluid from excessive agitation or circulation.	Flush and add new fluid.

✘ *Fluid ratio will be wrong.*

◆ *Purge all air from system before proportioning fluids.*

Pump Troubleshooting

This chart uses proportioning fluid gauges to determine pump malfunctions. Observe the gauge readings during the stroke direction indicated by the bold arrow, and immediately after closing the gun or mix manifold. Refer to other manuals to troubleshoot individual components.

TROUBLE AREA: Resin Pump Leakage

1. Throat packing
2. Piston packing
3. Piston ball check

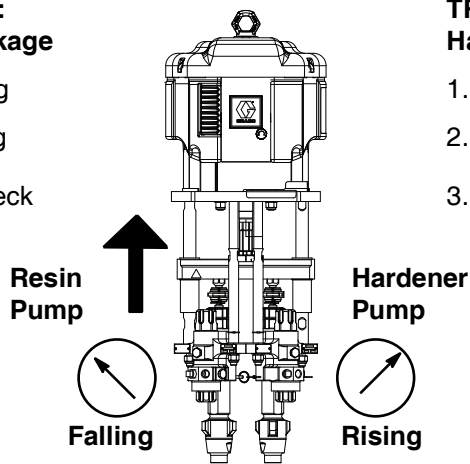

TROUBLE AREA: Hardener Pump Leakage

1. Throat packing
2. Piston packing
3. Piston ball check

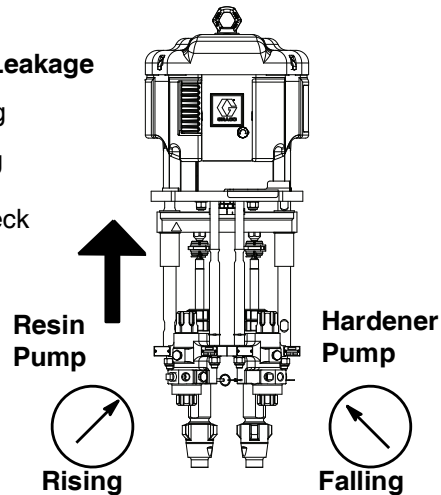

TROUBLE AREA: Resin Pump Leakage

1. Throat packing
2. Intake ball check

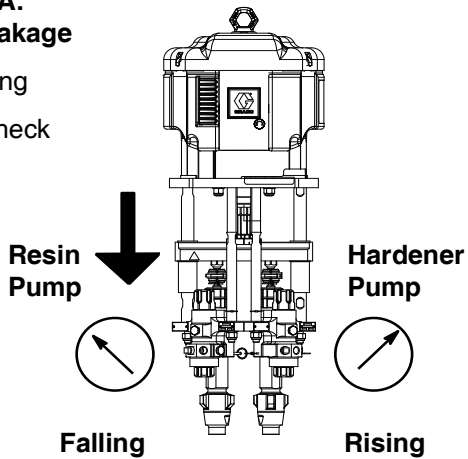

TROUBLE AREA: Hardener Pump Leakage

1. Throat packing
2. Intake ball check

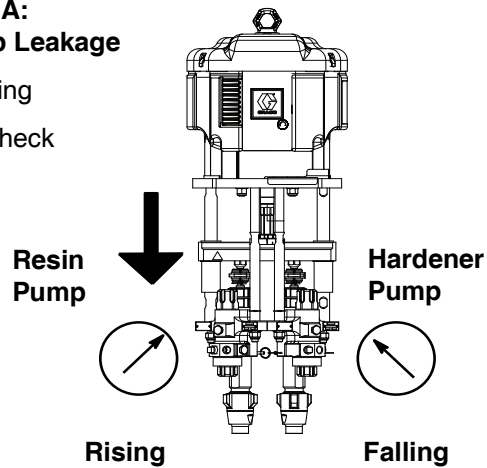

Repair

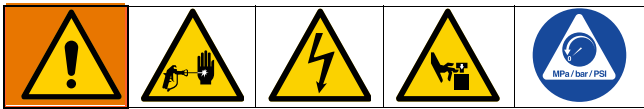

Follow the complete **Flushing** procedure starting on page 44, which includes pressure relief and full system flushing if service time may exceed pot life time before servicing fluid components and before transporting the system to a service area.

Pump Assembly Repair



To avoid serious injury due to the pump assembly falling, secure a hoist to the lift ring.

The displacement pumps and air motor may be removed and serviced separately or the entire pump and motor assembly can be removed with a hoist.

Pump Assembly Removal

1. Flush all system components. Follow the complete **Flushing** procedure starting on page 44.
2. Disconnect all hoses from the pump assembly.
3. Disconnect the hopper fluid lines from the pump fluid inlet (228).
4. Remove screws (6) and washers (5) under the tie plate (901). For additional parts identification, see **Parts** starting on page 60.

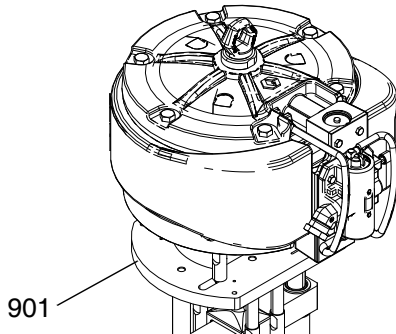

5. Use hoist to remove the pump assembly by the lift ring and carefully lift out of stand (1).

Remove XP Displacement Pump

1. Flush all system components. Follow the complete **Flushing** procedure starting on page 44.
2. Disconnect the hopper fluid lines from the pump fluid inlet (228).
3. Disconnects the outlet hose (12 or 24). For parts identification, see **Parts** starting on page 60.
4. Remove the spring clamp (930) and coupling (919).

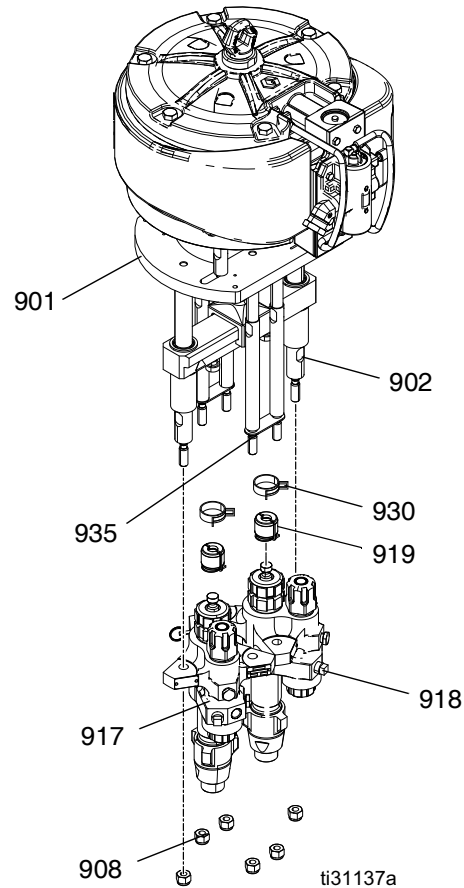

5. Use a wrench to hold the tie rod (902) flats to keep the rods from turning. Unscrew the nuts (908) from the tie rods and carefully remove the displacement pump (917 or 918) and lower straps (935).
6. Refer to the Xtreme Displacement Pump manual to service or repair the displacement pump.
7. Follow the steps in reverse order to reinstall the displacement pump.

NOTE: Torque nuts (908) to 95-105 ft-lb (129-142 N•m).

Remove Motor

1. Flush all system components. Follow the complete **Flushing** procedure starting on page 44.
2. Disconnect the air line from the air motor.
3. Remove the air motor rod cover (921) and pump guards (922).

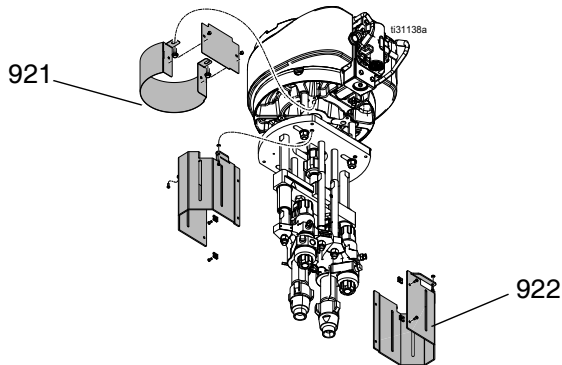

4. Use a wrench to hold the tie rod (902) flats to keep the rods from turning. Unscrew the nuts (908) from the tie rods.

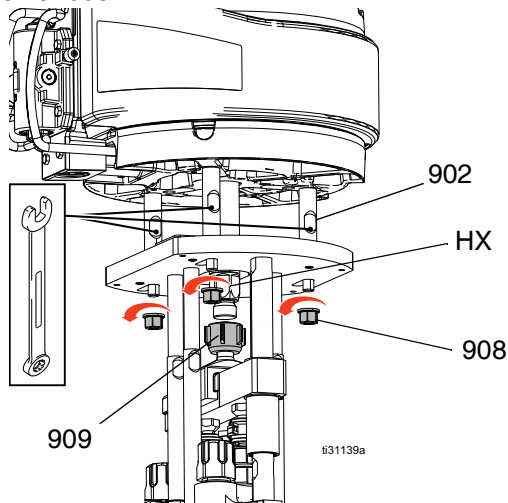

5. Place a wrench on the motor shaft hex flats (HX). Loosen coupling nut (909).
6. Use a hoist to remove the air motor by the lift ring.
7. Refer to the air motor manual to service or repair the air motor.

Recirculation Manifold with Over Pressure Relief Valves

1. Flush all system components. Follow the complete **Flushing** procedure starting on page 44.
2. Disconnect all fluid hoses from the material recirculation manifold (35).
3. Remove the mix manifold if it is assembled to the material recirculation manifold.
4. Loosen the two screws (37) that secure the manifold (35) to the cart (1).
5. Remove the two screws (37) and material recirculation manifold (35) from the cart (1).

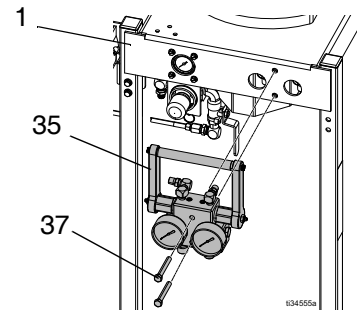

Replace Over Pressure Relief Valves

1. Flush all system components. Follow the complete **Flushing** procedure starting on page 44.
2. Ensure handle (712) is in the down position. Remove the screws (713), jam nut (704), handles (711), handle rod (712), clips (718), and springs (720).

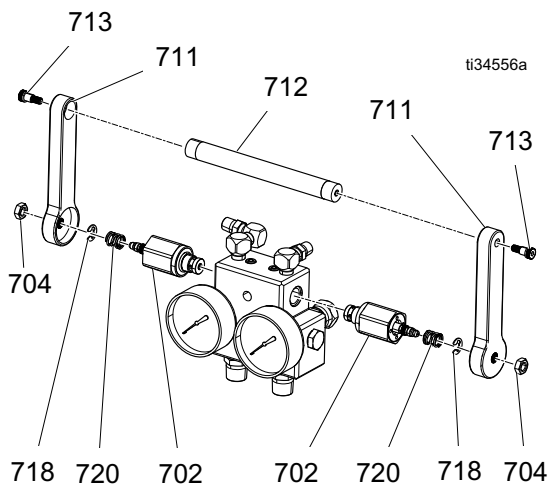

3. Unscrew both over pressure relief valves (702) from the manifold.
4. Apply blue threadlock to new over pressure relief valves (702) and install in the manifold. Torque to 28-32 ft-lb (38-43 N•m).

5. Place a spring (720) over each valve stem. Place a clip (718) in each valve stem groove to retain the springs.
6. Slide handle (711) onto valve stem and rotate approximately 90° until you feel it fully lock against the valve seat. Repeat for opposite side.
7. Remove handle then place handle (711) on valve stem (302) at the vertical, or near vertical, position.
8. Apply blue threadlock on the nut (704) threads and tighten the handle against the spring (720) and clip (718). Torque to 70-80 in-lb (7.9-9 N•m).
9. Place the rod (712) and the second handle (711) on second valve stem aligned with the opposite handle.
10. Repeat step 9.
11. Install two screws (713) in handles (711).
12. Check operation of the handle and valves.
13. Operate the handle in and out of the spray and circulate positions.
14. Check for clearance with fittings.

NOTE:

- Both valves should settle firmly into the spray position inward against the seats in the valve.
- Both valve stems should rotate out to their most extended positions when the handle is pulled down to the circulate position.

Material Recirculation Manifold Replacement Guide

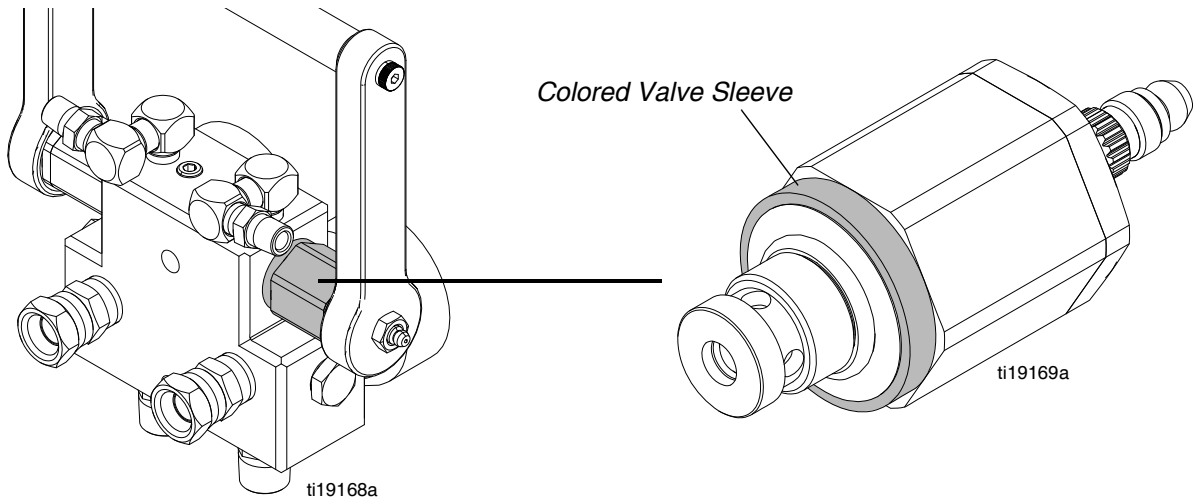

Material Recirculation Manifold Replacement Table

Circulation Manifold (35) Part	Relief Valve (302) Part	Valve Sleeve Color	Target Opening Pressure psi (MPa, bar)	Use with:
262783	262809	Gold	7100 (49, 490)	All XPs50-hf models
262806	262520	Silver	9250 (64, 638)	All XPs70-hf models

Parts

XP50s-hf and XP70s-hf Proportioner

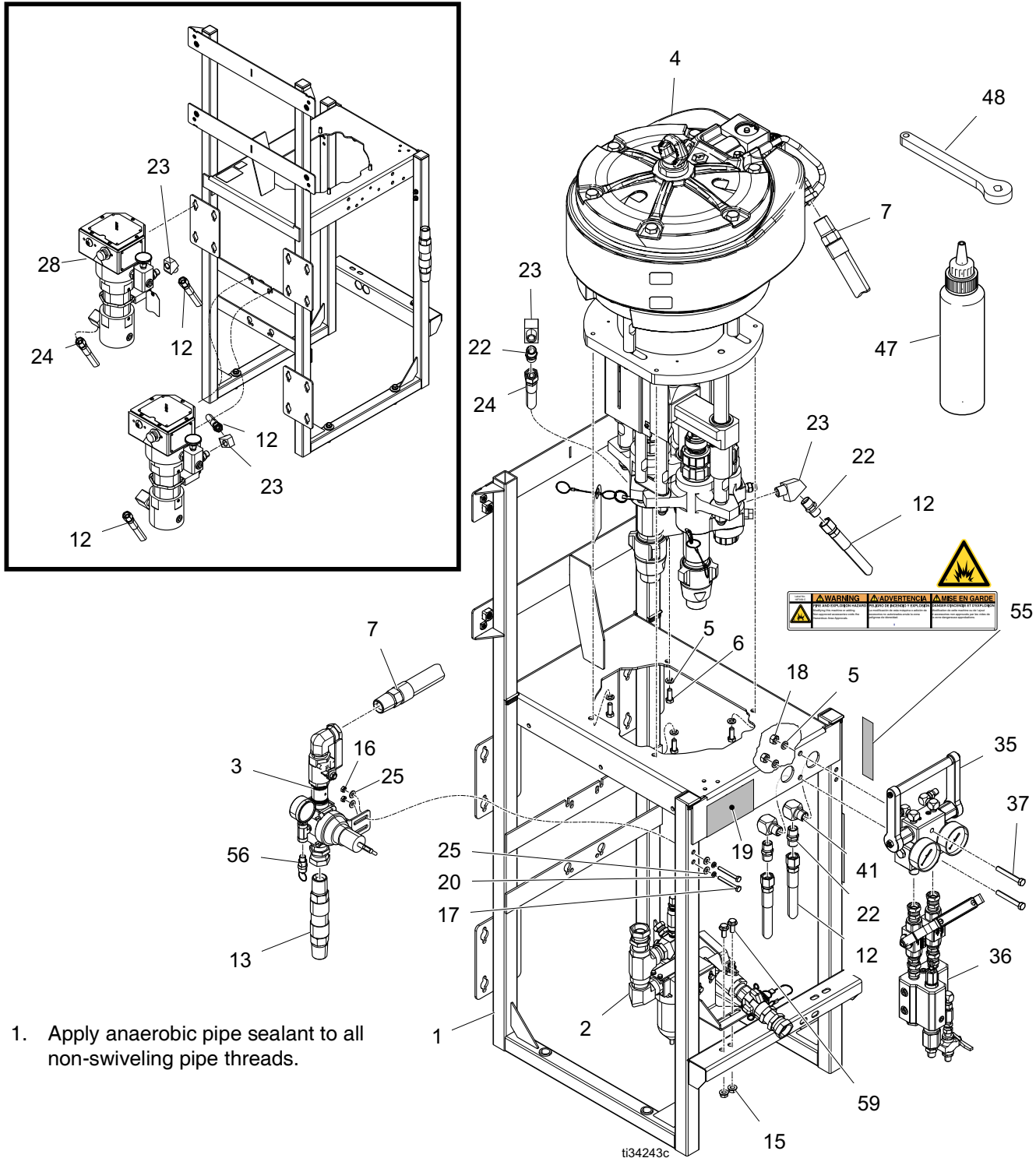

1. Apply anaerobic pipe sealant to all non-swiveling pipe threads.

XP50s-hf and XP70s-hf Proportioners (Continued)

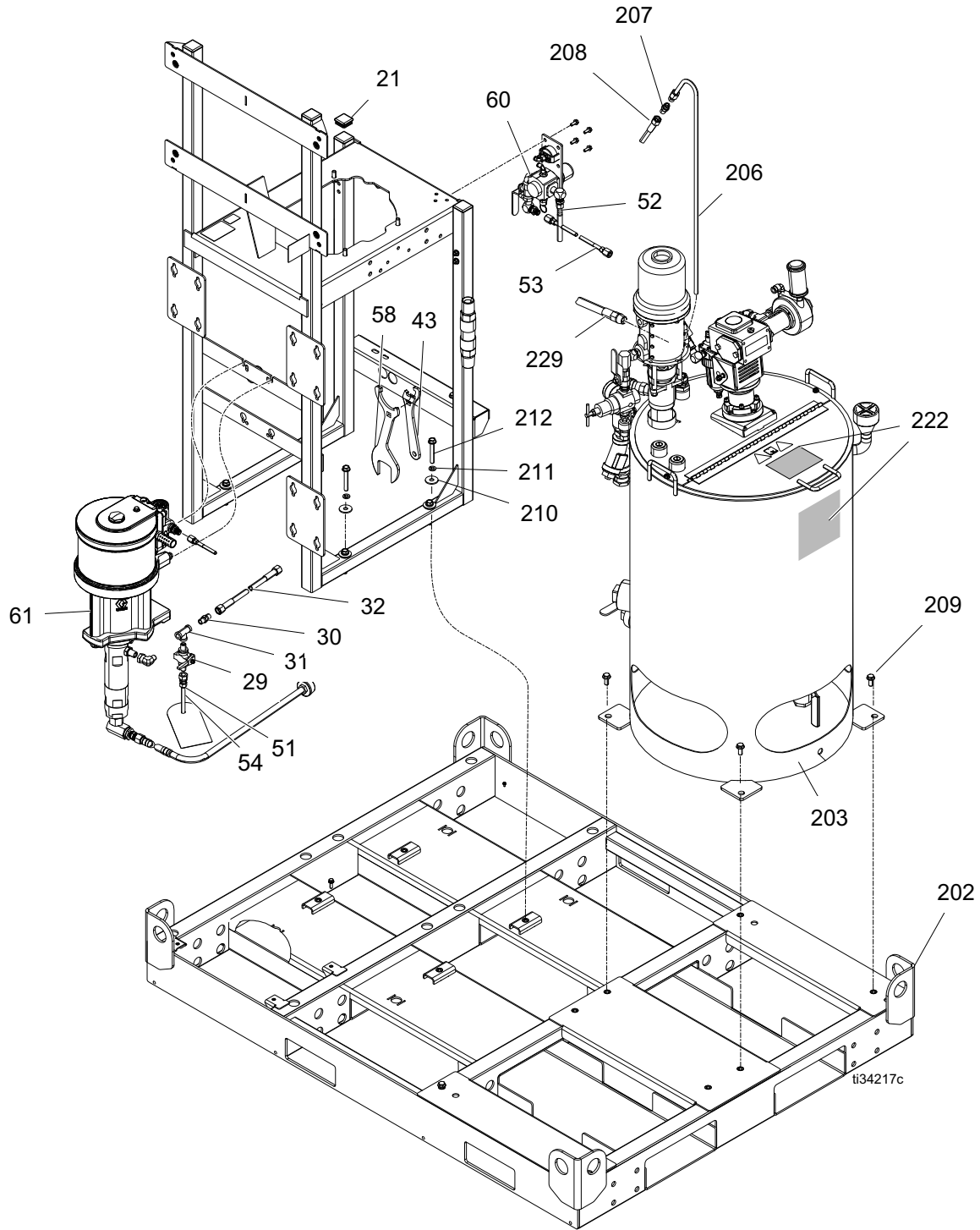

ti34217c

XP50s-hf and XP70s-hf Proportioners (Continued)

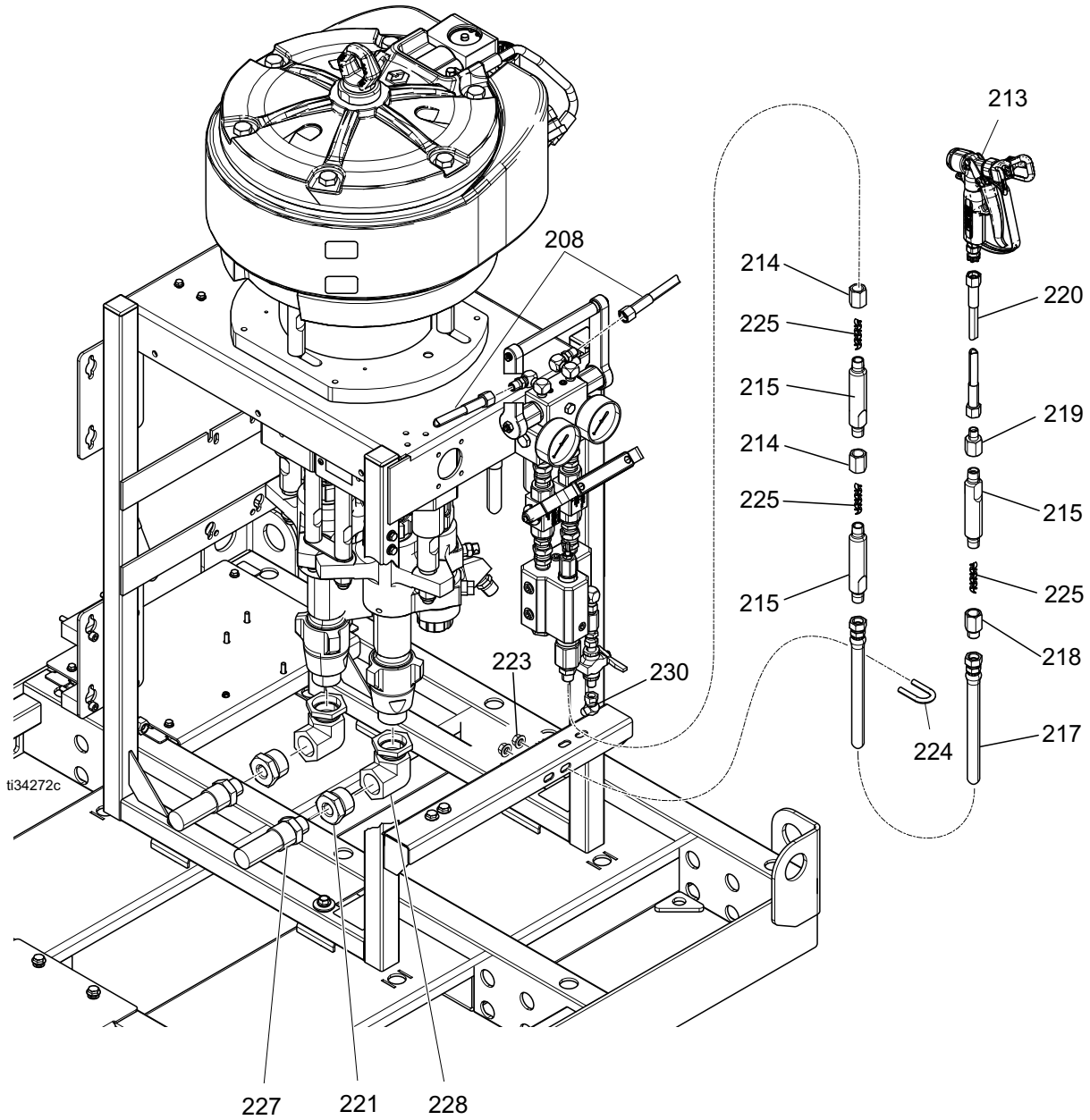

XP50s-hf and XP70s-hf Proportioners Parts List

Ref.	Part	Description	Qty.	Ref.	Part	Description	Qty.
1	25N579	CART, painted, XPs,	1	55▲	16F359	LABEL, warning, fire/exp hazard	1
2	25N583	MODULE, air controls, filter (see page 72)	1	56	-----	VALVE, safety (see page 79)	1
3	25N575	MODULE, air controls, regulator	1	58	16F615	TOOL, wrench, Xtreme	1
4	-----	PUMP (see page 79)	1	59	111192	SCREW, cap, hex head	2
5	100133	WASHER, lock, 3/8	6	60	24F126	MODULE, air controls, solvent	1
6	100101	SCREW, cap, hex head	4	61	262392	PUMP, solvent (see page 79)	1
7	17V986	HOSE, coupled, 1 in.	1	202	25N578	BASE, painted, XPs, pallet	1
12	H75004	HOSE, 7250 psi, 4 ft	3	206	17V987	TUBE, recirculation, material	2
13	17N487	HOSE, XP-hf Air Motor supply	1	207	116704	FITTING, adapter	2
15	112958	NUT, hex, flanged, 3/8-16	2	208	H52506	HOSE, recirculation material	2
16	100015	NUT, hex, flange head	2	209	111192	SCREW, cap, socket head	8
17	104429	SCREW, cap	2	210	108851	WASHER, plain	4
18	100131	NUT, hex	2	211	100133	WASHER, lock, 3/8	4
19	16F206	LABEL, XP, handles	1	212	123433	SCREW, cap, socket head	4
20	100016	WASHER, lock	2	213		GUN, ovl, hnd	1
21	111218	CAP, tube, square	4		XTR522	XTR5 (578xxx)	
22	158491	FITTING, nipple	4		XTR722	XTR7 (577xxx)	
23	15M987	FITTING, elbow, 60°	4	214	162024	COUPLING	2
24	H75002	HOSE, 7250 psi, 2 ft	1	215	262478	HOUSING, mixer	3
25	110755	WASHER, plain	4	217		HOSE, coupled	1
29	214037	VALVE, ball	1		H53825	5600 psi (578xxx)	
30	156971	FITTING, nipple	1		H73825	7250 psi (577xxx)	
31	104984	FITTING, tee	1	218	15B729	COUPLING	1
32	H42503	HOSE, solvent, outlet	1	219	150287	COUPLING	1
35		MANIFOLD, recirculation	1	220		HOSE, coupled	1
	262783	XP50 (578xxx)			H52510	5600 psi (578xxx)	
	262806	XP70 (577xxx)			H72510	7250 psi (577xxx)	
36	262807	MANIFOLD, mix, 1/2 in. valves	1	221	121620	FITTING, reducer,	2
37	106212	SCREW, cap, hex head	2	222	15R424	LABEL, A-B	1
41	158683	FITTING, elbow	2	223	101566	NUT, lock	2
43	16G819	TOOL, wrench, Xtreme, filter	1	224	124293	BOLT, u-bolt	1
47	206995	FLUID, TSL	1	225	248927	KIT, mixer element, (25 pack)	3
48	126786	TOOL, restrictor	1	227	214961	HOSE, coupled	2
51	205447	COUPLING, hose	1	228	121571	FITTING, elbow, female	2
52	16F537	HOSE, air, inlet, solvent control	1	229	203320	HOSE, coupled	2
53	15B772	HOSE, air, solvent pump	1	230	114030	UNION, adapter, swivel	1
54	061132	HOSE, circulation, solvent	1				

▲ Replacement safety labels, tags, and cards are available at no cost.

Water Jacketed Heated Hose Packages

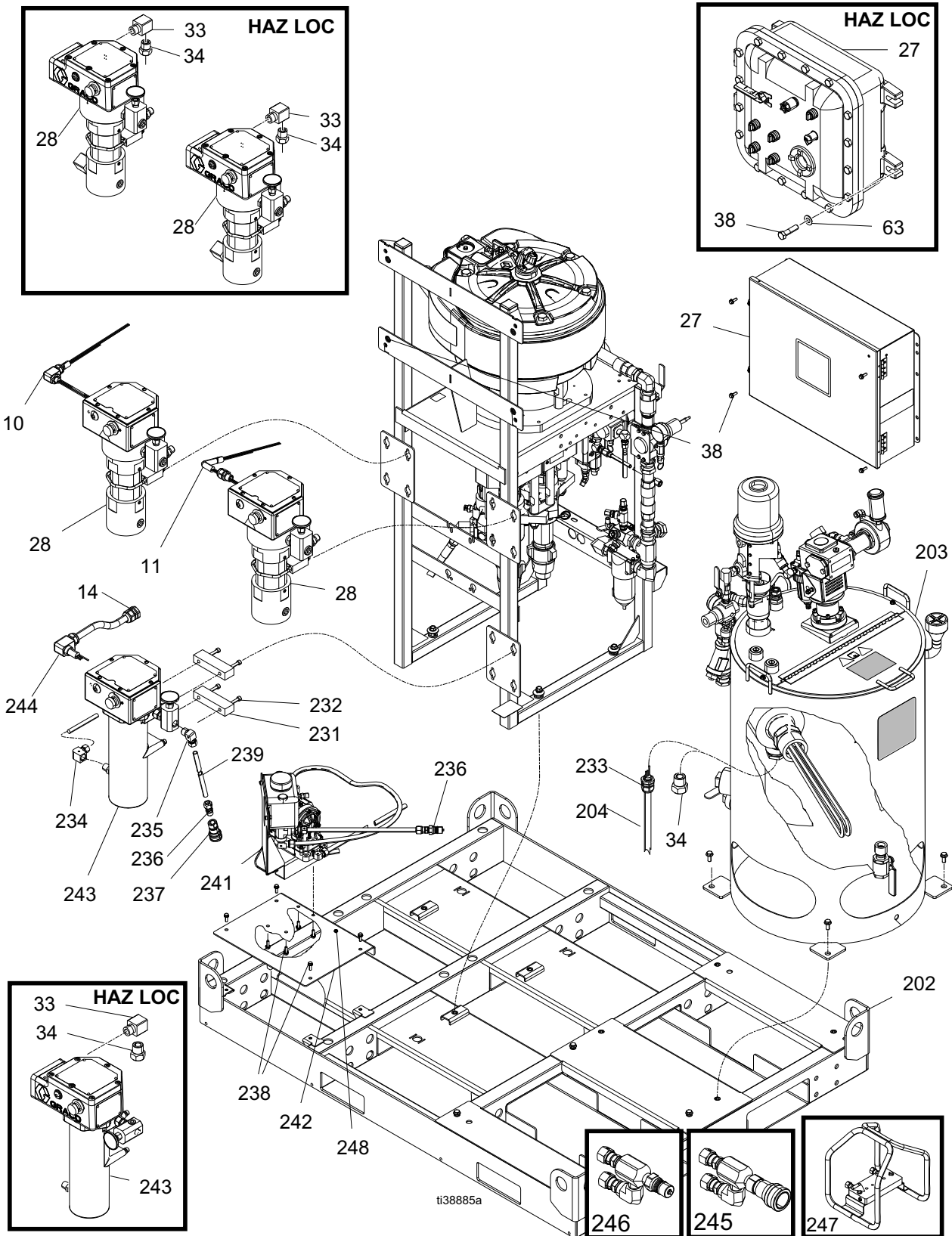

Water Jacketed Heated Hose Packages Parts List

Ref.	Part	Description	Qty.			
			240V		480V	
			Ordinary Locations	Hazardous Locations	Ordinary Locations	Hazardous Locations
			XXXX01	XXXX11	XXXX21	XXXX31
10	17N599	HARNESS, B heater, non-hazardous	1		1	
11	17N598	HARNESS, A heater, non-hazardous	1		1	
14	116171	BUSHING, strain relief	2		2	
27	26C580	JUNCTION BOX, 240V, non-hazardous	1			
	26C581	JUNCTION BOX, 240V, hazardous		1		
	26C582	JUNCTION BOX, 480V, non-hazardous			1	
	26C583	JUNCTION BOX, 480V, hazardous				1
28	25C961	HEATER, hf, 240V, non-hazardous	2			
	25C962	HEATER, hf, 240V, hazardous		2		
	26C471	HEATER, hf, 480V, non-hazardous			2	
	26C476	HEATER, hf, 480V, hazardous				2
33	166590	FITTING, bushing adapter		3		3
34	185065	ADAPTER, cable		5		5
38	110963	SCREW, cap, flanged head	4		4	
	C19075	SCREW, cap, hex head		4		4
63	111841	WASHER		4		4
203	26C482	HOPPER, heated, 240V	2	2		
	26C479	HOPPER, heated, 480V			2	2
204	17X398	HARNESS, hopper	2		2	
231	16P608	CLAMP, mounting, top, heater	2	2	2	2
232	117535	SCREW, cap, socket head	4	4	4	4
233	121603	GRIP, cord	2		2	
234	126896	FITTING, elbow	1	1	1	1
235	126898	FITTING, elbow	1	1	1	1
236	126900	FITTING, elbow	1	1	1	1
237	17D306	FITTING, coupler	1	1	1	1
238	113796	SCREW, flanged	8	8	8	8
239	17P759	TUBE	1	1	1	1
240	122032	NUT, wire (not shown)	10		10	
241	273093	PUMP, heated hose	1	1	1	1
242	17X552	BRACKET, recirc pump	1	1	1	1
243	245869	HEATER, hose, 240V, non-hazardous	1			
	245863	HEATER, hose 240V, hazardous		1		
	245870	HEATER, hose 480V, non-hazardous			1	
	245864	HEATER, hose, 480V, hazardous				1
244	17N600	HARNESS, WJ, hose heat	1		1	
245	17P594	FITTING, hose coupler	1	1	1	1
246	17S051	FITTING, hose nipple	1	1	1	1
247	24Z934	KIT, heater block, remote manifold	1	1	1	1
248	113974	SCREW, mach, slotted	1	1	1	1

Non-Heated Hose Packages

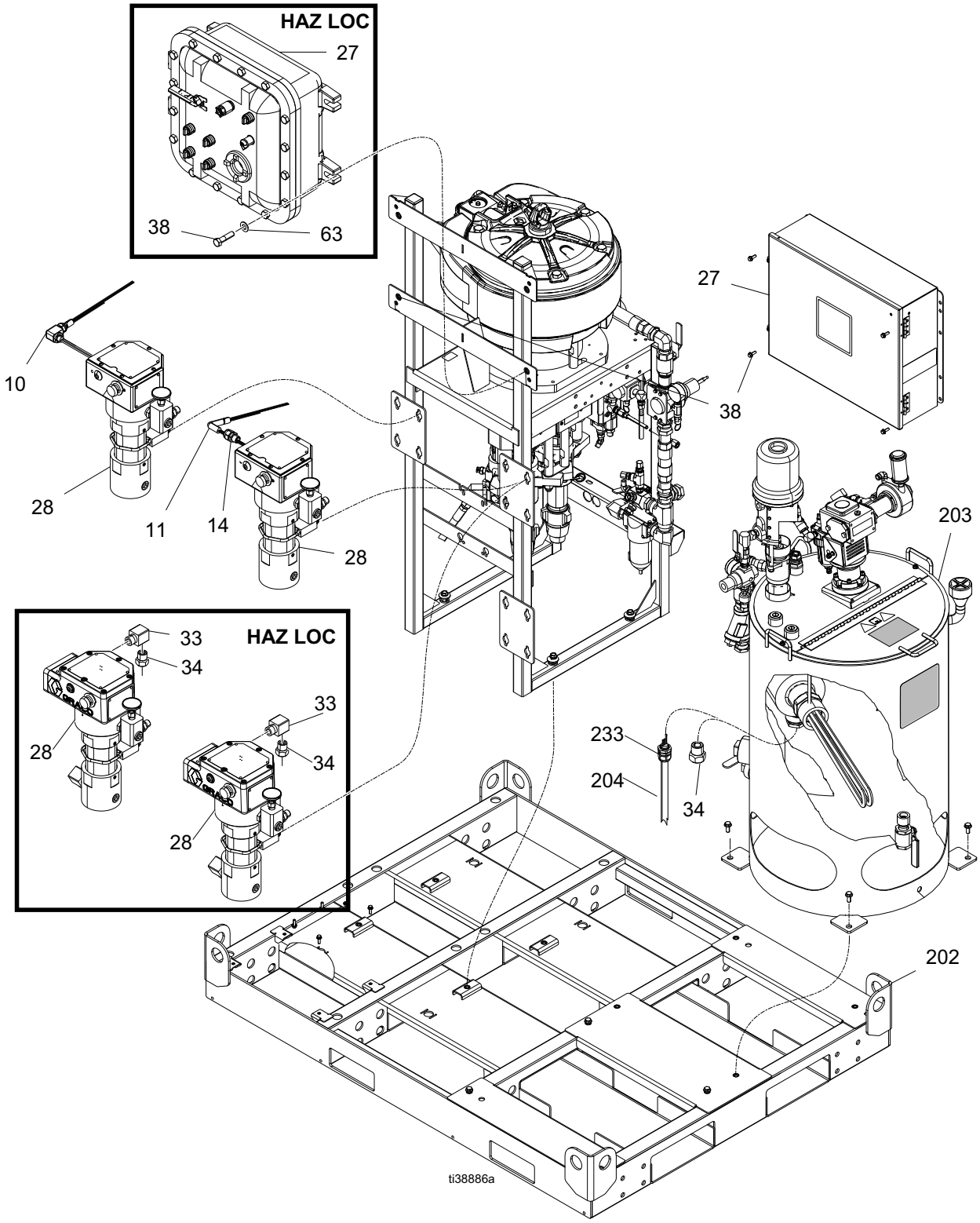

ti38886a

Non-Heated Hose Packages Parts List

Ref.	Part	Description	Qty.			
			240 V		480 V	
			Ordinary Locations	Hazardous Locations	Ordinary Locations	Hazardous Locations
			XXXX02	XXXX12	XXXX22	XXXX32
10	17N599	HARNESS, B heater, non-hazardous	1		1	
11	17N598	HARNESS, A heater, non-hazardous	1		1	
14	116171	BUSHING, strain relief	1		1	
27	26C580	JUNCTION BOX, 240V, non-hazardous	1			
	26C581	JUNCTION BOX, 240V, hazardous		1		
	26C582	JUNCTION BOX, 480V, non-hazardous			1	
	26C583	JUNCTION BOX, 480V, hazardous				1
28	25C961	HEATER, hf, 240V, non-hazardous	2			
	25C962	HEATER, hf, 240V, hazardous		2		
	26C471	HEATER, hf, 480V, non-hazardous			2	
	26C476	HEATER, hf, 480V, hazardous				2
33	166590	FITTING, bushing adapter		2		2
34	185065	ADAPTER, cable		4		4
38	110963	SCREW, cap, flanged head		4		4
	C19075	SCREW, cap, hex head	4		4	
63	111841	WASHER		4		4
203	26C482	HOPPER, heated, 240V	2	2		
	26C479	HOPPER, heated, 480V			2	2
204	17X398	HARNESS, hopper	2		2	
233	121603	GRIP, cord	2		2	
240	122032	NUT, wire (not shown)	8		8	

Non-Hazardous Location Electric Heated Hose Packages

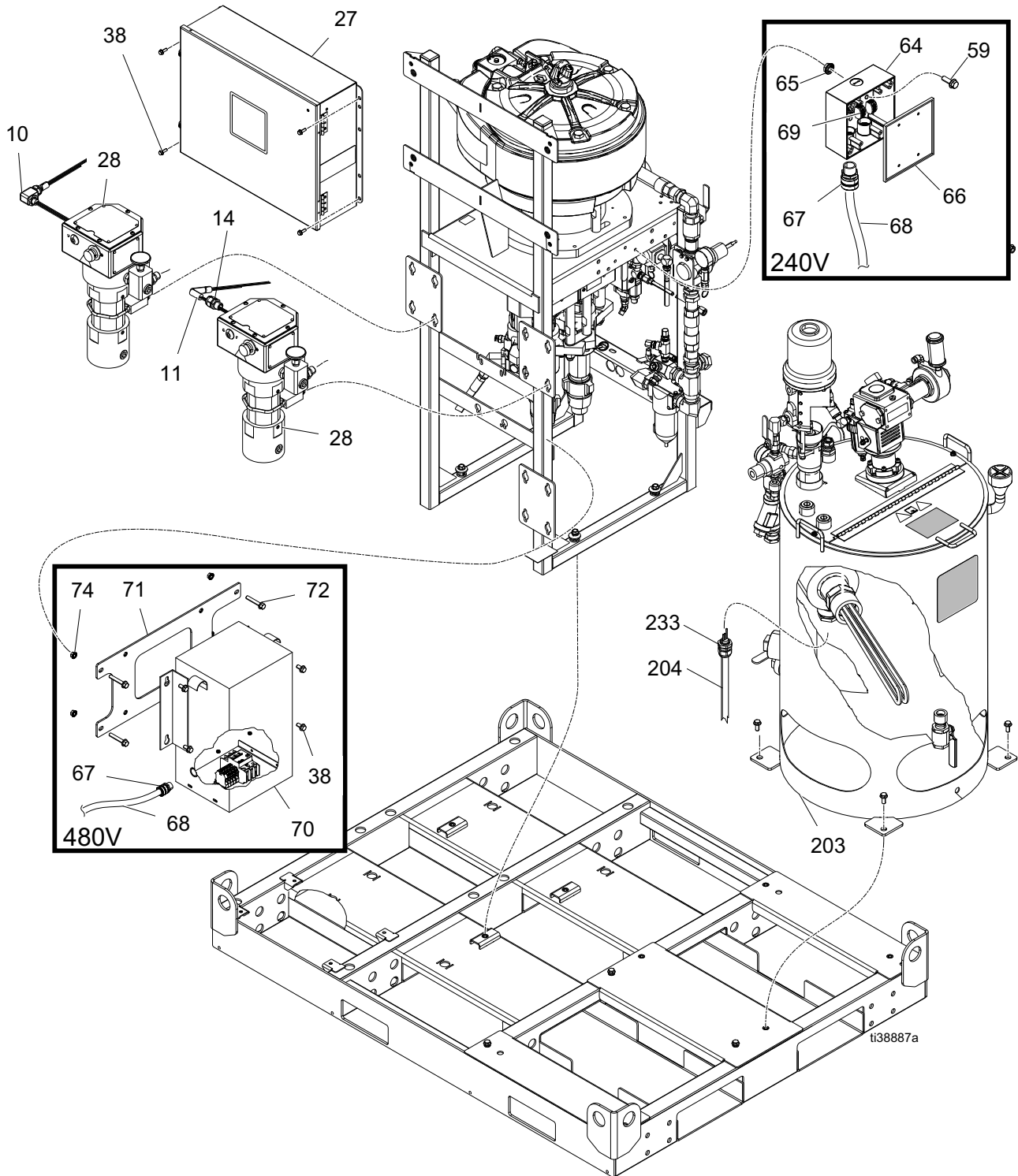

Hazardous Location Electric Heated Hose Packages

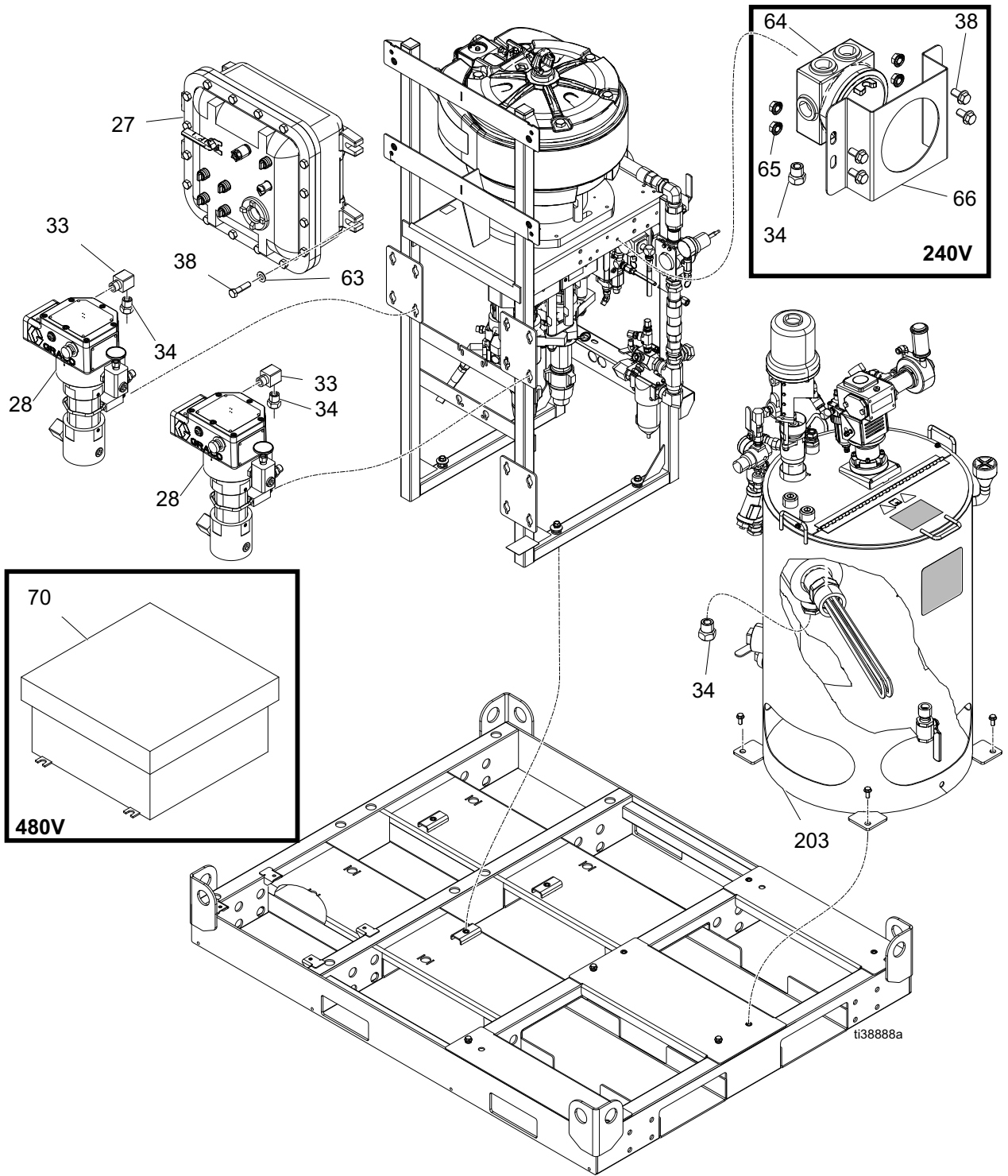

ti38888a

Electric Heated Hose Packages Parts List

Ref.	Part	Description	Qty.			
			240 V		480 V	
			Ordinary Locations	Hazardous Locations	Ordinary Locations	Hazardous Locations
			XXXX03	XXXX13	XXXX23	XXXX33
10	17N599	HARNESSES, B heater, non-hazardous	1		1	
11	17N598	HARNESSES, A heater, non-hazardous	1		1	
14	116171	BUSHING, strain relief	1		1	
27	26C899	JUNCTION BOX, 240V, non-hazardous	1			
	26C905	JUNCTION BOX, 240V, hazardous		1		
	26C904	JUNCTION BOX, 480V, non-hazardous			1	
	26C906	JUNCTION BOX, 480V, hazardous				1
28	25C961	HEATER, hf, 240V, non-hazardous	2			
	25C962	HEATER, hf, 240V, hazardous		2		
	26C471	HEATER, hf, 480V, non-hazardous			2	
	26C476	HEATER, hf, 480V, hazardous				2
33	166590	FITTING, bushing adapter		2		2
34	185065	ADAPTER, cable		5		4
38	110963	SCREW, cap, flanged head		4		4
	C19075	SCREW, cap, hex head	4		8	
63	111841	WASHER		4		4
64	18C158	SPLICE BOX	1			
	18B948	SPLICE BOX, explosion-proof		2		2
65	115942	NUT	3			
	112958	NUT		4	4	
66	18C151	COVER, splice box	1			
	19B335	BRACKET, splice box		1		
67	19Y807	BUSHING, strain relief	1		1	
68	19B130	CORD, cable	1		1	
69	128986	CONNECTOR, splice	2			
70	26C791	TRANSFORMER			1	
	19B356	TRANSFORMER, 5kV, hazardous				1
71	19B359	BRACKET, transformer			1	
72	132001	BOLT, flange, serrated			4	
73	112395	SCREW, cap		4	4	
74	112958	NUT, hex flanged		4	4	
75	25T264	KIT, fittings (not shown)	1	1	1	1
203	26C482	HOPPER, heated, 240V	2	2		
	26C479	HOPPER, heated, 480V			2	2
204	17X398	HARNESSES, hopper	2		2	
233	121603	GRIP, cord	2		2	
240	122032	NUT, wire (not shown)	8		8	

Air Control Filter 25N583 Parts

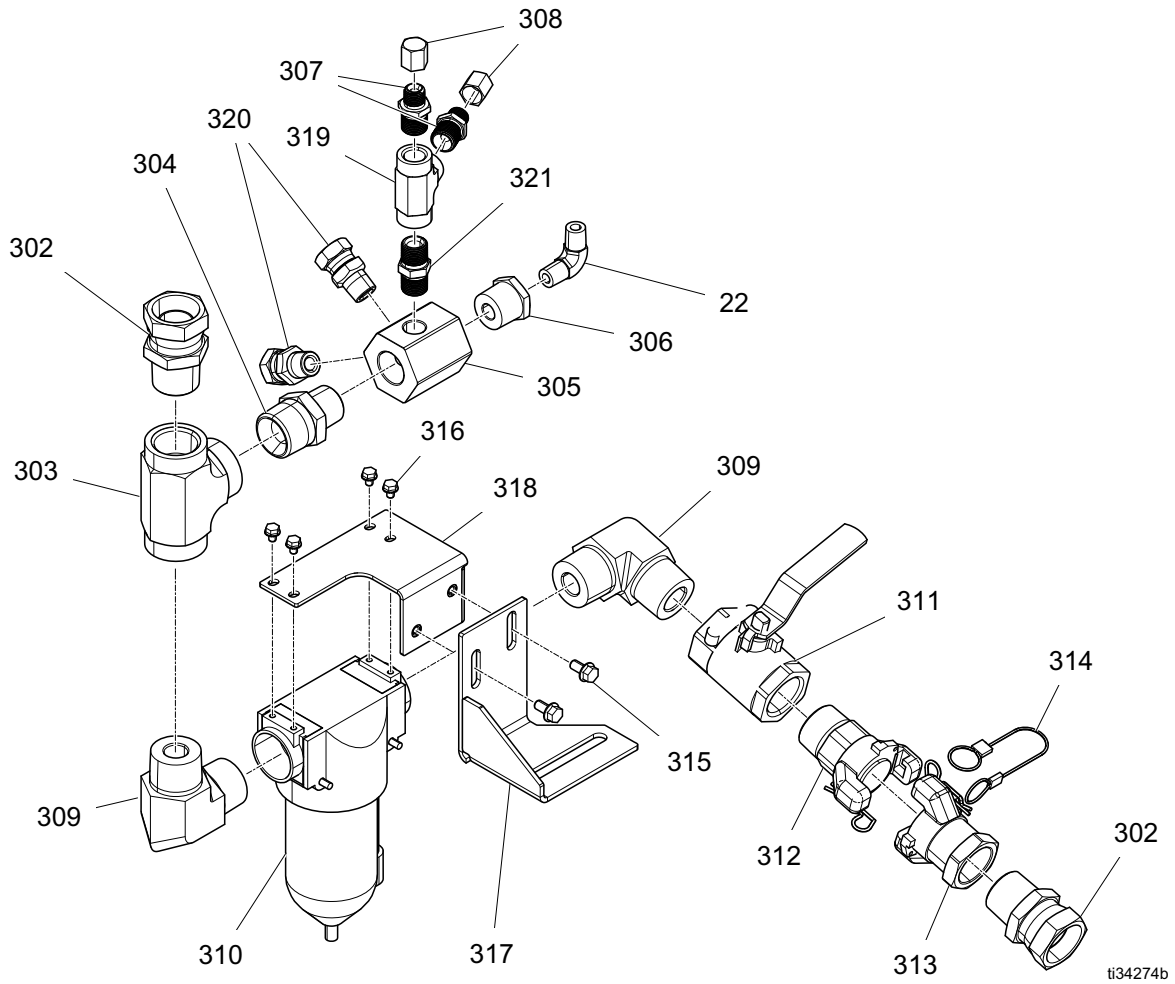

Parts List

Ref.	Part	Description	Qty.	Ref.	Part	Description	Qty.
302	116648	FITTING, swivel, 1 in. m x f	2	313	127785	COUPLING, universal, 1 in. nptf	1
303	17N485	FITTING, tee, 1 x 1 x 1 npt(f), cs, 2.2k	1	314	16W586	CABLE, lanyard, whip check	1
304	158555	FITTING, nipple, 1 x 3/4 npt	1	315	113161	SCREW, flange, hex hd	2
305	15E145	MANIFOLD, air distribution	1	316	16P338	SCREW, mach, serrated hex head	4
306	100615	BUSHING, hex steel	1	317	17X550	BRACKET, XPs, filter, mount, painted	1
307	157350	ADAPTER	3	318	17X551	BRACKET, XPs, filter, painted	1
308	115781	CAP plug	2	319	114526	FITTING, tee	1
309	17N486	FITTING, elbow, 1 in. npt	2	320	155665	UNION, adapter	2
310	17N462	FILTER, air, 1 in. npt	1	321	156849	PIPE, nipple	1
311	113163	VALVE, ball, vented, 1	1	322	111763	FITTING, elbow, 1/4 npt	1
312	127784	COUPLING, universal, 1 in. nptm	1				

Air Control Regulator 25N575 Parts

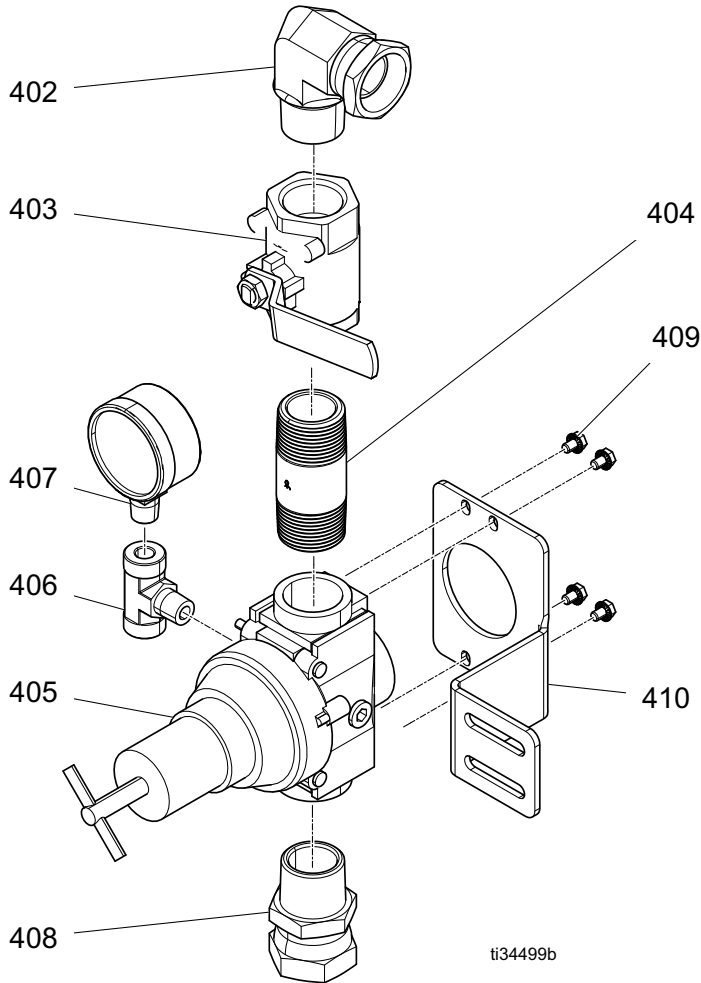

Ref.	Part	Description	Qty.	Ref.	Part	Description	Qty.
402	119363	FITTING, swivel, pipe	1	406	108638	FITTING, pipe, tee	1
403	113163	VALVE, ball, vented, 1.0	1	407	100960	GAUGE, press air	1
404	17S719	FITTING, 1 in. npt x 3 in., nipple	1	408	116648	FITTING, swivel, 1 in. m x f	1
405	17N463	REGULATOR, air, 1 in. npt	1	409	16P338	SCREW, mach, serrated hex head	4
				410	17X553	BRACKET, XPs, regulator, painted	1

Solvent Pump 262392 Parts

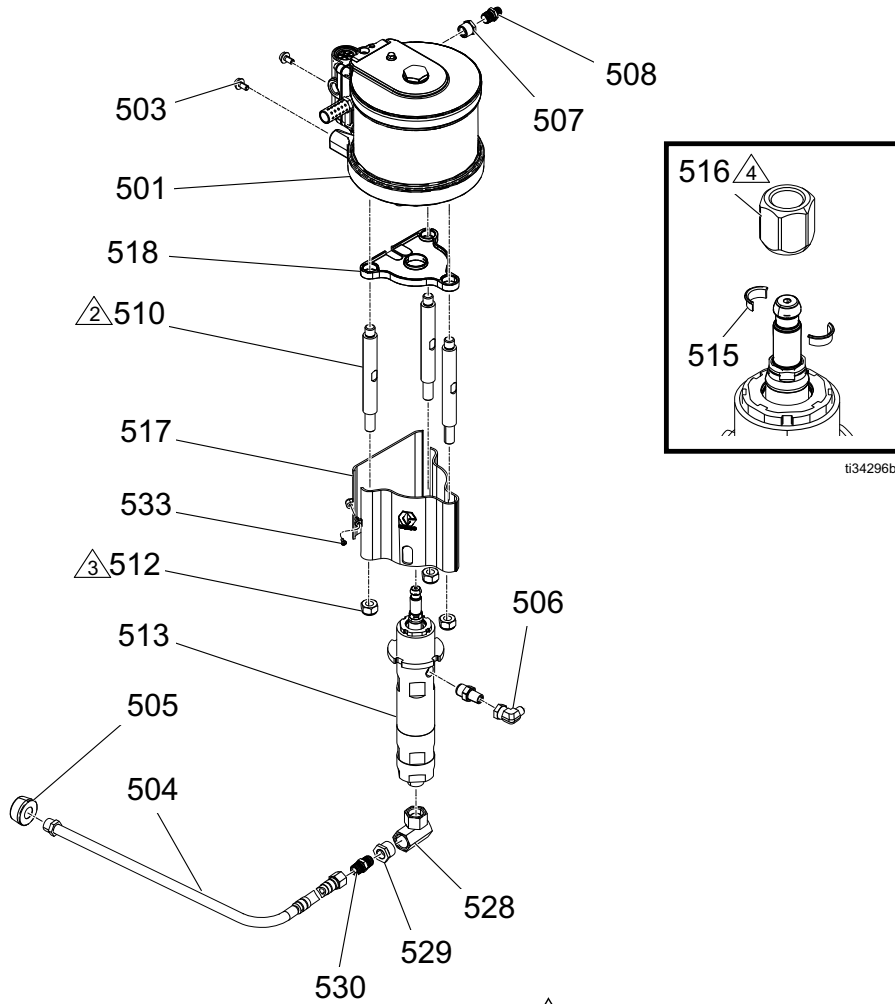

△² Torque to 50-55 ft-lb (68-75 N•m).
 △³ Torque to 50-60 ft-lb (68-81 N•m).

△⁴ Torque to 75-80 ft-lb (102-108 N•m).

Ref.	Part	Description	Qty.	Ref.	Part	Description	Qty.
501	24F079	MOTOR, air, 6 in., std, slvt only	1	513	LW050A	LOWER, assy, 50 cc	1
503	111799	SCREW, cap, hex hd	4	514	15T337	RESERVOIR, tsl, 50 cc lwr 7 1/2 motor (not shown)	2
504	244675	HOSE, coupled, suction	1	515	184128	COLLAR, coupling	1
505	108143	STRAINER	1	516	15T311	NUT, coupler	1
506	116395	FITTING, swivel, elbow	1	517	277743	SHIELD, 6.0/7.5 in.	1
507	100081	BUSHING, pipe	1	518	15V028	SHIELD, drip	1
508	157350	ADAPTER	1	528	156589	FITTING, union, adapter, 90 deg	1
510	15M662	ROD, tie	3	529	100505	BUSHING, pipe	1
511	16U431	ADAPTER, 50 cc, pump lower (not shown)	1	530	156849	PIPE, nipple	1
512	15U606	NUT, lock, m16 x 2	3	533	105335	SCREW, mach, pnh	1

Solvent Air Control 24F126 Parts

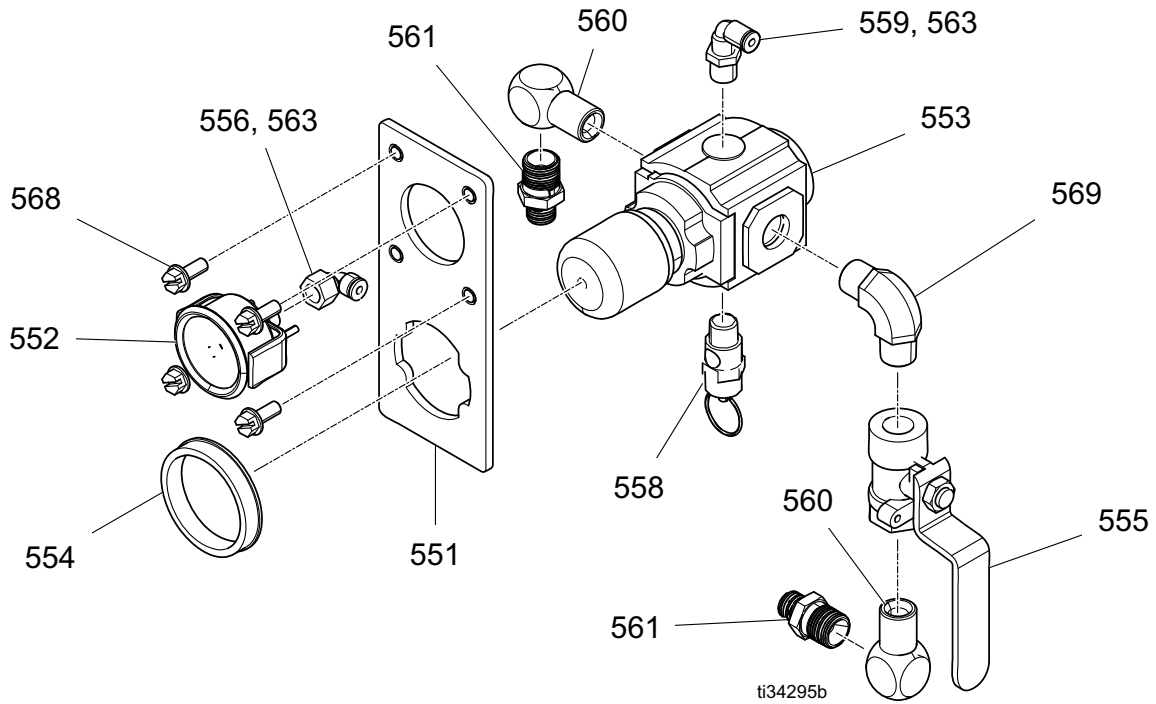

Ref.	Part	Description	Qty.
551	-----	PANEL, air controls, slvt, painted	1
552	15T500	GAUGE, pressure, air, pl mnt, 1/8	1
553	15T536	REGULATOR, air, 3/8 npt	1
554	16F810	NUT, regulator, steel	1
555	114362	VALVE, ball, air	1
556	15T498	FITTING, 90, swvl, 5/32 t x 1/8 fnpt	1
558	113498	VALVE, safety, 110 psi	1
559	15T937	FITTING, elbow, swivel 1/4 npt x 5/32 t	1
560	155699	FITTING, elbow, street	2
561	164672	ADAPTER	2
563	054753	TUBE, nylon, rd, black	0.75
568	108296	SCREW, mach, hex wash hd	4
569	109544	FITTING, elbow, pipe, male	1

Heater Block Remote Manifold Kit

(Water Jacketed Heated Hose Packages Only)

Kit 24Z934

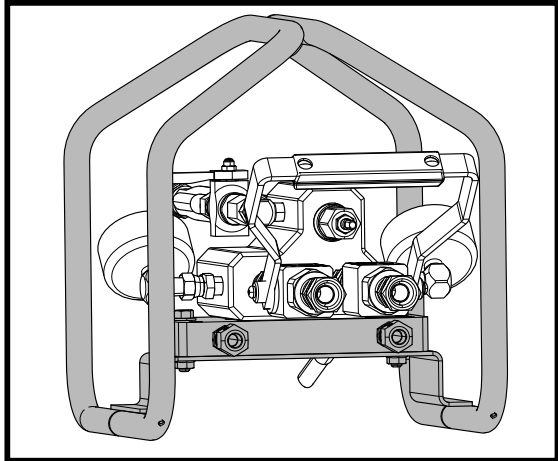

ti31155a

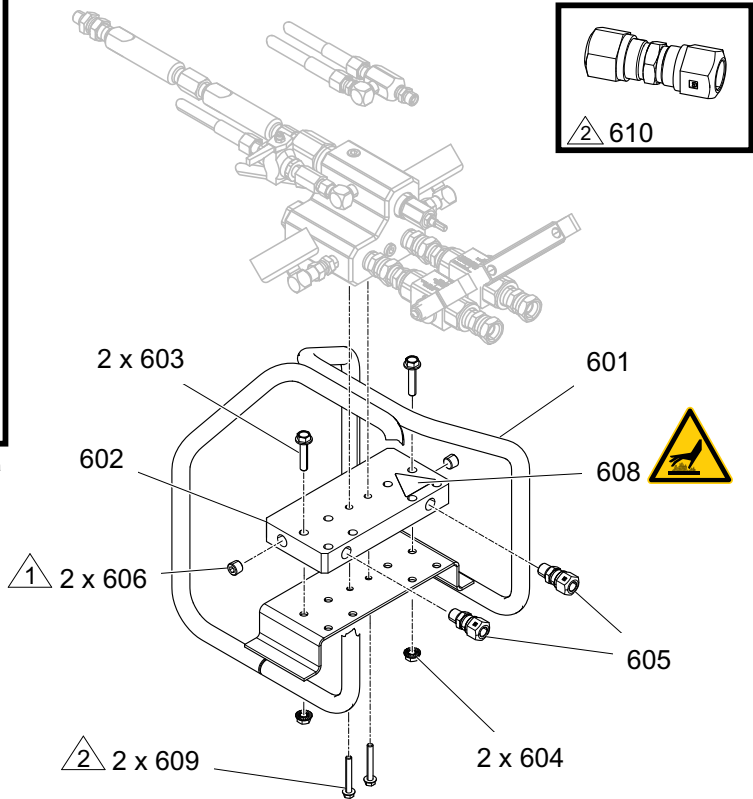

1 Apply thread sealant to all non-swiveling pipe threads.

2 Supplied loose, not installed.

Ref.	Part	Description	Qty.
601	24F834	CARRIAGE, weldment, remote manifold	1
602	16T294	PLATE, heater transfer, PFP 2k	1
603	110837	SCREW, flange, hex	2
604	110996	NUT, hex, flange head	2
605	126692	FITTING, tube, NPT x tube	2
606	100721	PLUG, pipe	2
608▲	189285	LABEL, safety, burn	1
609	120736	SCREW, hex flange HD	2
610	126894	FITTING, union, 1/2 tube x 1/2 tube	2
611*	054960	TUBE, red, nylon, 0.375 (9.5 mm) ID (1.5 ft)	1
612*	054961	TUBE, blue, nylon, 0.375 (9.5 mm) ID (1.5 ft)	1

* Supplied loose, not installed.

▲ Replacement safety labels, tags, and cards are available at no cost.

Material Recirculation Manifold with Over Pressure Relief Valve

Assembly 262783 (XP50s-hf); 262806 (XP70s-hf)

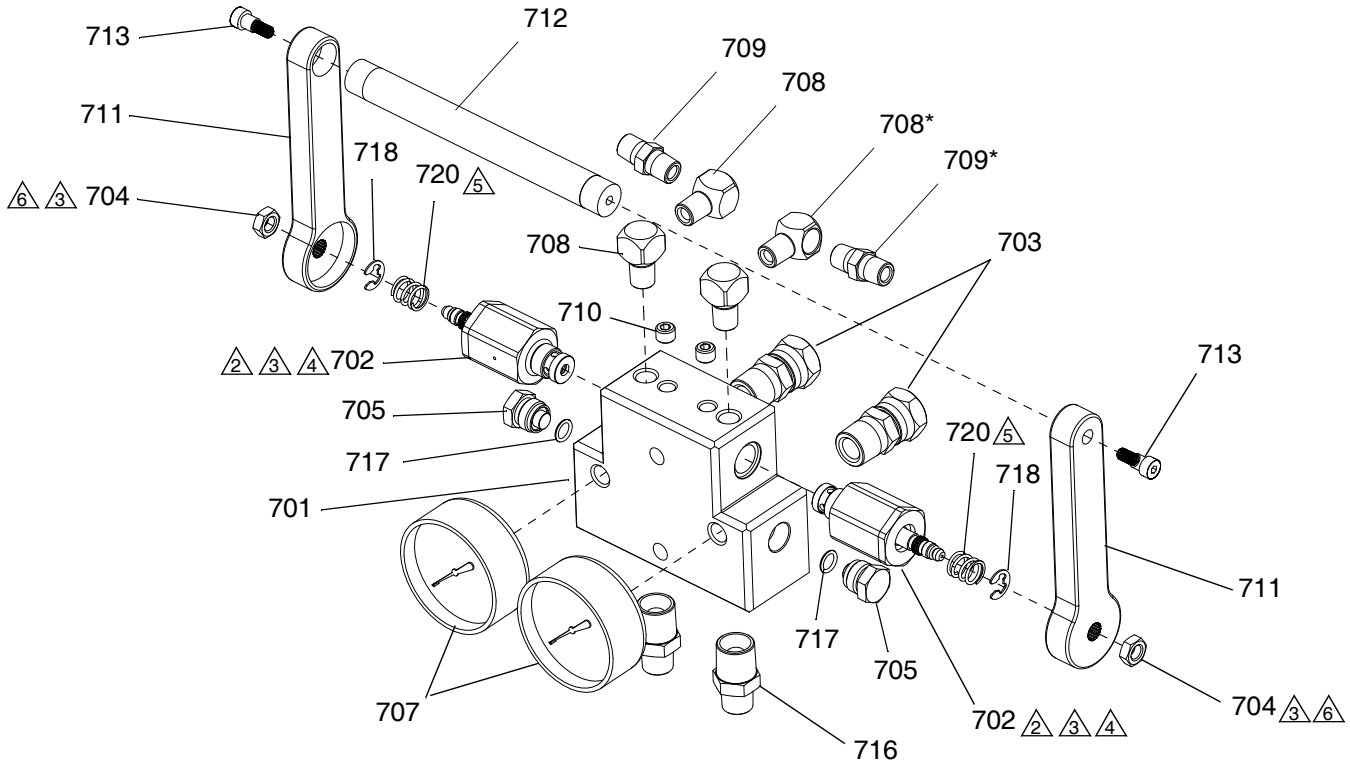

r_258988_3a0420a_1c

1. Apply anaerobic pipe sealant to all non-swiveling pipe threads.

△2 Torque to 28-32 ft-lb (38-43 N•m).

△3 Apply blue anaerobic adhesive to threads.

△4 Further tighten either valve (302) as required to line up handle straight across.

△5 Apply grease to spring ends.

△6 Torque to 70-90 in-lb (7.9-9 N•m).

Ref	Part	Description	Qty
701	16D693	BLOCK, manifold, recirculation	1
702†	262520	VALVE, over pressure relief, silver, XP70s-hf	2
◆	262809	VALVE, over pressure relief, gold, XP50s-hf	2
703	156684	UNION; 1/2 in. male x female	2
704	112309	NUT, hex, jam	2
705	198241	PLUG, port, pressure; 11/16-24	2
707	114434	GAUGE, pressure, fluid, sst; 10k psi	2
708	100840	FITTING, elbow, street; 1/4 npt	4
709	156971	FITTING, nipple; 1/4 npt x npsm	2
710	557349	PLUG, dry seal 1/8 npt	2
711	16E334	HANDLE, manifold	2
712	16E332	ROD, connecting, handle	1
713	124859	SCREW, button head	2
716	156684	FITTING, nipple, 1/2 npt x 1/2 npt	2

Ref	Part	Description	Qty
717	121399	O-RING, solvent resistant	2
718	124676	RING, snap, external	2
720	150829	SPRING, compression	2
751X	159239	FITTING, nipple, pipe, reducing	2
752X	156173	UNION, swivel	2

X Not shown. Shipped loose.

◆ For XP50s-hf systems only.

† For XP70s-hf systems only.

NOTE: Loose fittings are supplied with replacement manifold to also fit Series A (XP70s) Proportioners with 3/8 in. mix manifold ball valves.

* Fitting orientation can be modified to allow for easier routing of recirculation lines. Remove fitting (708) and reinstall fitting (709).

Diaphragm Pump 273093 Parts

(Water Jacketed Heated Hose Packages Only)

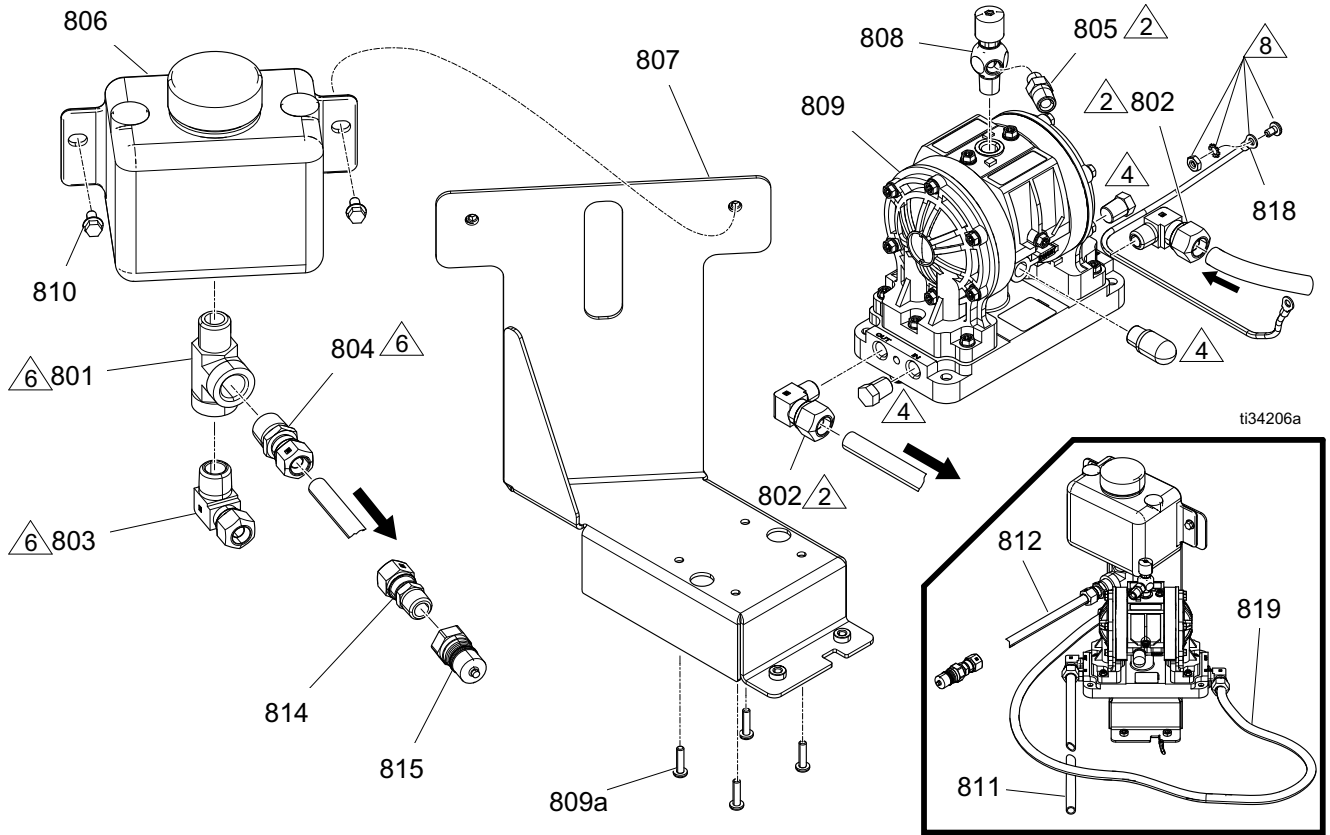

- △ Apply thread sealant to all non-swiveling pipe threads.
- △ Orient fittings as shown.
- △ Install two loose plugs and muffler provided with pump in the ports indicated.





- △ Orient fittings approximately 15 degrees away from pump.
- △ Install ground wire between screw and washer. The nut is held in the slot of the pump.

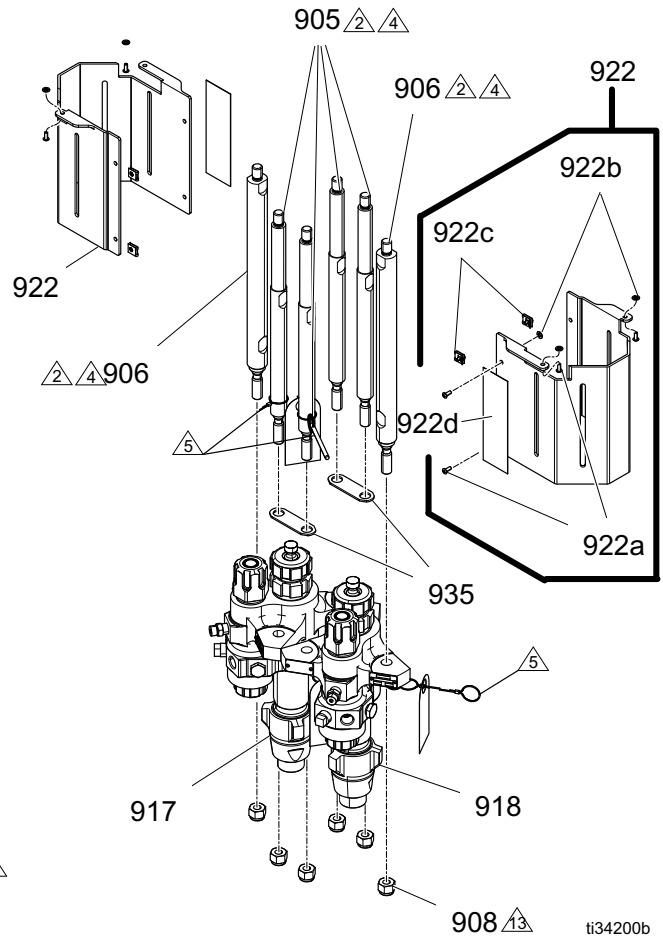
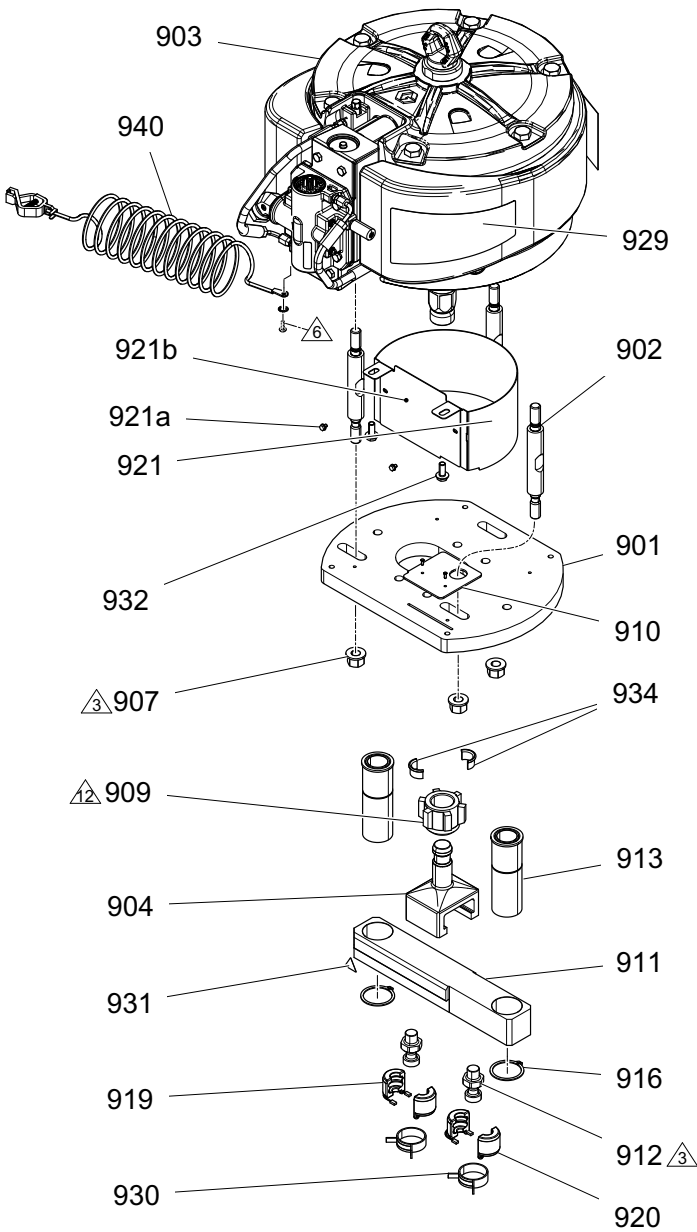

Ref.	Part	Description	Qty.	Ref.	Part	Description	Qty.
801	108126	FITTING, tee, street	1	809	24T761	PUMP, acetal, w/pvdf check, husky	1
802	126897	FITTING, elbow, 1/2 tube x 1/4 nptm	2	810	113161	SCREW, flange, hex hd	2
803	126898	FITTING, elbow, 1/2 tube x 1/2 nptm	1	811	17N910	TUBE, red, 0.5 o.d., nylon	2
804	126899	FITTING, 1/2 tube x 1/2 nptm	1	812	17N911	TUBE, blue, 0.5 o.d., nylon	1
805	16D939	FITTING, nipple, reducing	1	814	126900	FITTING, 1/2 tube x 3/8 nptm	1
806	16R871	BOTTLE, overflow, 1/2 npt	1	815	17D307	FITTING, nipple, quick coupling	1
807	17P088	BRACKET, XP-hf, re-circ, painted	1	818	17N595	WIRE, ground, door to enclosure	1
808	206264	VALVE, needle	1	819	248208	HOSE, coupled	1

XP-hf Pump Assembly Parts



ti34200b

-  Torque to 50-60 ft-lb (68-81 N•m).
-  Torque to 145-155 ft-lb (196-210 N•m).
-  Apply medium strength (blue) threadlock to top thread only.
-  Pins and lanyards must be positioned toward the outside of the pump as shown. Allow ends of lanyard to hang freely.
-  Remove ground screw and washer from the motor, then use to install ground wire.

-  Torque together to 230-250 ft-lb (312-339 N•m).
-  Torque together to 95-105 ft-lb (129-142 N•m).

XP-hf Pump Assembly Parts List

Ref.	Part	Description	Qty.	Ref.	Part	Description	Qty.
901	273087	PLATE, XP-hf, motor	1	921a	16P338	SCREW, mach, serrated hex hd	2
902	273086	ROD, tie, 4 in. long, 1 in. dia	3	921b	17N312	PLATE, XP-hf, finger guard	1
903	273088	MOTOR, air, 13 in.	1	922	273092	COVER, pump	2
904	273085	ROD, adapter	1	922a	121803	SCREW, cap, button head	8
905	262468	ROD, tie, 14.25 long, w/shoulder	4	922b	124172	WASHER, retaining, nylon, 10-32	8
906	262469	ROD, tie, 14.25 long, 1.25 dia	2	922c	124665	NUT, captive, 10-32	4
907	129383	NUT, 5/8-11, flanged, sst	3	922d▲	15T468	LABEL, warning	2
908	101712	NUT, lock	6	930	124078	CLAMP, spring, constant-tension	2
909	184096	NUT, yoke	1	931▲	15H108	LABEL, safety, warning, pinch	1
910	17R501	BRACKET, ratio indicator	1	932	111192	SCREW, cap flange hd	2
911	273090	YOKE, pump assembly	1	934	184130	COLLAR, coupling	1
912	273091	ROD, adapter, Xtreme, hf	2	935	16E882	STRAP, lowers	2
913	262472	SLEEVE, bearing	2	940	244525	WIRE, grounding assembly	1
916	123976	RING, snap, external	2				
921	273089	BRACKET, XP-hf, finger guard	1				

▲ Replacement safety labels, tags, and cards are available at no cost.

Ref.	Description	57710x	57720x	57730x	57740x	57810x	57820x	57830x	57840x	Qty.
4	PUMP, assembly	572100	572200	572300	572400	573100	573200	573300	573400	1
917	PUMP, lower, A	L14AC0	L18AC0	L22XC0	L22XC0	L22AC0	L29AC0	L29AC0	L29AC0	1
918	PUMP, lower, B	L14AC0	L090C0	L072C0	L054C0	L22AC0	L14AC0	L097C0	L072C0	1
919	COUPLING, A	244819	244819	244819	244819	244819	244819	244819	244819	1
920	COUPLING, B	244819	247167	247167	247167	244819	244819	247167	247167	1
929	LABEL, XP-hf	17N281	17N281	17N281	17N281	17N282	17N282	17N282	17N282	4
56	VALVE, safety	113498	114055	113498	114055	113498	113498	114055	16M190	1

Recommended Spare Parts

Keep these spare parts on hand to reduce downtime.

Pump Repair Kits

See **Models** (page 10) to see what pumps are used on your system. See lower manual for repair kits.

Pump Filter O-Rings (packs of 10)

262483, Top o-ring
244895, Middle o-ring
262484, Bottom o-ring

Recirculation/Overpressure Valve (see page 59)

XP50-hf: 262809, gold
XP70-hf: 262520, silver

15K692, Seal Mix Manifold Check Valve Cartridge

NOTE: 15K692 must be replaced when cleaning the check valves.

1/2 in. Mix Manifold Inlet Ball Valves

24M601, Ball valve repair kit
262740, Spare valve (no handle)
262739, Spare valve (single handle)

248927, Spare Mix Elements (pack of 25)

1/2 in. OD x 12 element, acetal plastic

248837, XTR Spray Gun Repair Kit

XHD010, Seat/Seal Kit for XHD RAC Tips (5 pack)

XHDxxx, Spray Tips

See spray gun manual for tips.

Accessories and Kits

PressureTrak™ Kit, 25C452

Monitors pressures to provide ratio assurance on XP-hf plural component sprayers in hazardous and non-hazardous locations.

Twistork® Agitator Kit, 256274

For mixing viscous materials held within a 55 gallon drum. See manual 312769 for more information.

5:1 Feed Pump Kit, 256276

For supplying viscous materials from a drum to XP-hf system. See manual 312769 for more information.

5:1 Drum Feed Kit, 256255

One 5:1 pump feed kit and one Twistork agitator kit for mixing and supplying viscous materials from a 55 gallon drum to XP-hf system. See manual 312769 for more information.

10:1 Drum Feed Kit, 256433

For supplying highly viscous material from a 55 gallon drum to XP-hf system. See manual 312769 for more information.

1-1/2 in. ID Hose Flex Feed Kit, 262820

XP Wall Mount Bracket, 262812

Works with air systems.

Leg Stand, 24M281

Includes wall bracket 262812.

1/2 in. Ball Valve Upgrade Kit for Mix Manifold, 24M593

Remote Mix Manifold with Heater Block, 24Z934

A mounting carriage with a heater block to circulate water-jacketed hose heat to maintain heat on the mix manifold.

Remote Mix Manifold Carriage, 262522

A protective guard to mount mix manifold remote. See mix manifold manual 3A0590 for more information.

Mix Manifold Restrictor Wrench, 126786

Gun Splitter with Carriage, 262826

One splitter valve to use one, two, or three spray guns with the system. Provides independent flush for two guns. Optional 3rd gun port does not have independent flush. See manual 3A2573 for more information.

Filter Element, 116635

40 micron filter element.

Automatic Float Drain Kit, 17P521

Internal auto float drain for filter bowl.

2:1 Feed Pump Kit, 256275

For supplying viscous materials from a drum to XP-hf system. See manual 312769 for more information.

2:1 Drum Feed Kit, 256232

One T2 pump feed kit and one Twistork agitator kit for mixing and supplying viscous materials from a 55 gallon drum to XP-hf system. See manual 312769 for more information.

Wall Line Powered Pressure Monitor Kit, 26C008*

Air Turbine Powered Pressure Monitor Kit, 26C009

Automatically monitors difference between A and B pressures when at spray pressure and shuts down the system if there is a problem.

** Not approved for Hazardous locations*

Dimensions

System Dimensions

Top View

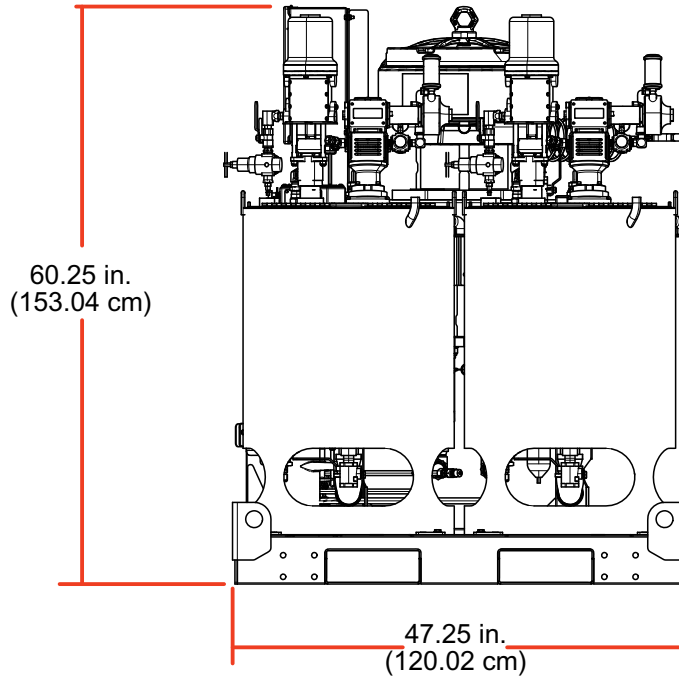

Side View

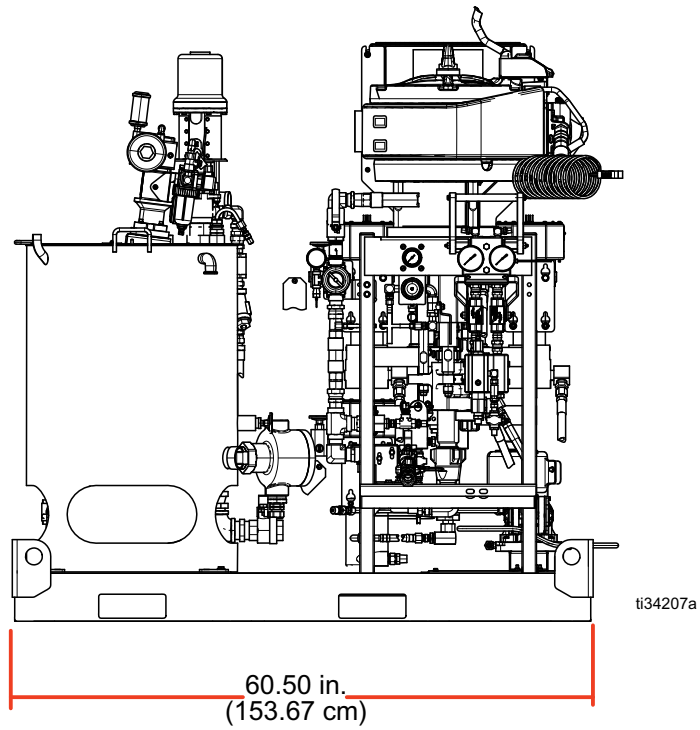

Technical Specifications

XPs-hf System		
	U.S.	Metric
Output		
Maximum Fluid Working Pressure	See Models section beginning on page 10.	
Combined Fluid Output (cc/cycle)	See Models section beginning on page 10.	
Pressure Ratio	See Models section beginning on page 10.	
Fluid Flow at 20 cpm	See Models section beginning on page 10.	
Maximum Storage Time	5 years (To maintain original performance, replace soft seals after 5 years of inactivity)	
Air Specifications		
Required Air Flow	185 cfm (minimum)	5.23 m ³ /min (minimum)
Supply Pressure	30-100 psi	2.0-6.7 bar, 0.2-0.67 MPa
Inlet Size	1 in. npsm	2.54 cm npsm
Inlet Filtration	40-micron filter/separator included	
Electrical Specifications		
	See XPs-hf Wiring Diagram , page 26	
Filtration		
Feed Pump Outlet/Y-Strainer	20 mesh	
XP Pump Outlets	30 mesh	
XTR Spray Gun	60 mesh	
Viscosity		
Gravity Feed	200 - 20,000 cps (pourable)	
Pressure Feed	Any viscosity that will not require feed pressure more than 15% of outlet pressure	
Temperature		
CE (North America) Operating	40-130 °F (41-104 °F)	4-54 °C (5-40 °C)
Storage	30-160 °F	1-71 °C
Maximum Fluid Temperature	160 °F	71 °C
Wetted Materials		
Housings and Manifold	Carbon steel with electroless nickel plating	
Displacement Pump Packings	Carbon filled PTFE, proprietary UHMWPE	
Solvent Pump	Stainless steel, PTFE, UHMWPE, aluminum, tungsten carbide	
Hoses	Plated carbon steel, Nylon	
Feed Pump	Plated carbon steel, PTFE	
Agitator	Stainless steel	
Hopper	Stainless steel, brass, nickel plating	
Miscellaneous Parts	Carbide, acetal, solvent resistant plastics	
Dry Weight (does not include stand alone transformer)		
XXXX01	1350 lb	612 kg
XXXX02	1300 lb	590 kg
XXXX03	1325 lb	596 kg
XXXX11	1350 lb	612 kg
XXXX12	1300 lb	590 kg
XXXX13	1475 lb	700 kg
XXXX21	1475 lb	700 kg
XXXX22	1425 lb	646 kg
XXXX23	1450 lb	658 kg

XXXX31	1475 lb	700 kg
XXXX32	1425 lb	646 kg
XXXX33	1450 lb	658 kg

Sound Data		
Sound Power measured at 70 psi (0.48 MPa, 4.8 bar), 20 cpm, per ISO-9614-2	Greater than 96 dBA	
Sound Pressure tested at 3.28 ft (1 m) from equipment	Greater than 86.8 dBA	

Proportioner		
	U.S.	Metric
Input		
Maximum air input	100 psi	6.7 bar, 0.67 MPa
Air inlet size	1 in. npsm	
Fluid pump inlets	1-1/4 npt (m)	
Output		
Fluid gauge manifold	1/2 in. npt(f)	
Fluid mix manifold inlets (ball valves)	1/2 in. npsm	
Mix manifold material outlet	1/2 npt(f)	
Sound Data		
	See XL 10k Air Motor manual for sound data.	
Air consumption per 1 gpm (3.78 lpm) of flow		
XPs70-hf	75 cfm at 100 psi	2.12 m3/min at 6.7 bar, 0.67 MPa
XPs50-hf	60 cfm at 100 psi	1.7 m3/min at 6.7 bar, 0.67 MPa

Double Wall Hopper		
	U.S.	Metric
Temperature (set point)	110 °F	43 °C
Spray material capacity	25 gallons	94.6 liters
Heating fluid capacity	12 gallons	53 liters

Feed Pump		
	U.S.	Metric
Input		
Maximum air input	100 psi	6.7 bar, 0.67 MPa
Air inlet size	3/8 in. npt(f)	
Output		
Maximum working pressure	500 psi	34.4 bar, 3.4 MPa
Fluid outlet size	3/4 in. npt(f)	
Flow at maximum pump speed: (66 cycles/min)	2.5 gallons per minute	9.5 liters per minute
Air consumption per 1 gpm (3.78 lpm) of flow		
	8 cfm at 100 psi	0.23 m3/min at 6.7 bar, 0.67 MPa
Sound Data		
	See Monark Air Motor manual for sound data.	

Xtreme Duty Agitator		
	U.S.	Metric
Input		
Maximum air input	100 psi	6.7 bar, 0.67 MPa
Air inlet size	3/8 in. npsm	
Air Consumption		
30 rpm at 20 psi (1.4 bar, 0.14 MPa)	7 cfm	0.198 m ³ /min
60 rpm at 80 psi (5.5 bar, 0.55 MPa)	30 cfm	0.850 m ³ /min
Maximum free speed at 100 psi (6.7 bar, 0.67 MPa)	60 cfm	1.70 m ³ /min
Speed		
Maximum shaft speed	60 rpm	
Gear ratio	20:1	
Torque:		
Stall torque at maximum pressure	1120 in-lb	127 N•m
Sound Data		
See XD Agitator manual for sound data.		
Solvent Pump		
	U.S.	Metric
Input		
Air pressure	10 - 100 psi	0.67 MPa - 6.7 bar
Air inlet size	1/2 in. npt(f)	
Output		
Maximum working pressure	4500 psi	3.1 MPa, 31 bar
Fluid outlet size	3/8 in. npt	
Flow at maximum pump speed (60 cpm)	0.9 gpm	3.0 lpm
Air Consumption		
Per 0.5 gpm (1.89 lpm) of flow	20 cfm @ 70 psi	0.57 m ³ /min at 0.48 MPa, 4.83 bar
Sound Data		
See your Merkur air motor manual.		

Recycling and Disposal

End of Product Life

At the end of a product's useful life, recycle it in a responsible manner.

California Proposition 65

CALIFORNIA RESIDENTS

 **WARNING:** Cancer and reproductive harm – www.P65warnings.ca.gov.

Graco Standard Warranty

Graco warrants all equipment referenced in this document which is manufactured by Graco and bearing its name to be free from defects in material and workmanship on the date of sale to the original purchaser for use. With the exception of any special, extended, or limited warranty published by Graco, Graco will, for a period of twelve months from the date of sale, repair or replace any part of the equipment determined by Graco to be defective. This warranty applies only when the equipment is installed, operated and maintained in accordance with Graco's written recommendations.

This warranty does not cover, and Graco shall not be liable for general wear and tear, or any malfunction, damage or wear caused by faulty installation, misapplication, abrasion, corrosion, inadequate or improper maintenance, negligence, accident, tampering, or substitution of non-Graco component parts. Nor shall Graco be liable for malfunction, damage or wear caused by the incompatibility of Graco equipment with structures, accessories, equipment or materials not supplied by Graco, or the improper design, manufacture, installation, operation or maintenance of structures, accessories, equipment or materials not supplied by Graco.

This warranty is conditioned upon the prepaid return of the equipment claimed to be defective to an authorized Graco distributor for verification of the claimed defect. If the claimed defect is verified, Graco will repair or replace free of charge any defective parts. The equipment will be returned to the original purchaser transportation prepaid. If inspection of the equipment does not disclose any defect in material or workmanship, repairs will be made at a reasonable charge, which charges may include the costs of parts, labor, and transportation.

THIS WARRANTY IS EXCLUSIVE, AND IS IN LIEU OF ANY OTHER WARRANTIES, EXPRESS OR IMPLIED, INCLUDING BUT NOT LIMITED TO WARRANTY OF MERCHANTABILITY OR WARRANTY OF FITNESS FOR A PARTICULAR PURPOSE.

Graco's sole obligation and buyer's sole remedy for any breach of warranty shall be as set forth above. The buyer agrees that no other remedy (including, but not limited to, incidental or consequential damages for lost profits, lost sales, injury to person or property, or any other incidental or consequential loss) shall be available. Any action for breach of warranty must be brought within two (2) years of the date of sale.

GRACO MAKES NO WARRANTY, AND DISCLAIMS ALL IMPLIED WARRANTIES OF MERCHANTABILITY AND FITNESS FOR A PARTICULAR PURPOSE, IN CONNECTION WITH ACCESSORIES, EQUIPMENT, MATERIALS OR COMPONENTS SOLD BUT NOT MANUFACTURED BY GRACO. These items sold, but not manufactured by Graco (such as electric motors, switches, hose, etc.), are subject to the warranty, if any, of their manufacturer. Graco will provide purchaser with reasonable assistance in making any claim for breach of these warranties.

In no event will Graco be liable for indirect, incidental, special or consequential damages resulting from Graco supplying equipment hereunder, or the furnishing, performance, or use of any products or other goods sold hereto, whether due to a breach of contract, breach of warranty, the negligence of Graco, or otherwise.

FOR GRACO CANADA CUSTOMERS

The Parties acknowledge that they have required that the present document, as well as all documents, notices and legal proceedings entered into, given or instituted pursuant hereto or relating directly or indirectly hereto, be drawn up in English. Les parties reconnaissent avoir convenu que la rédaction du présente document sera en Anglais, ainsi que tous documents, avis et procédures judiciaires exécutés, donnés ou intentés, à la suite de ou en rapport, directement ou indirectement, avec les procédures concernées.

Graco Information

For the latest information about Graco products, visit www.graco.com.

For patent information, see www.graco.com/patents.

TO PLACE AN ORDER, contact your Graco distributor or call to identify the nearest distributor.

Phone: 612-623-6921 or Toll Free: 1-800-328-0211 Fax: 612-378-3505

*All written and visual data contained in this document reflects the latest product information available at the time of publication.
Graco reserves the right to make changes at any time without notice.*

Original instructions. This manual contains English. MM 3A6283

Graco Headquarters: Minneapolis

International Offices: Belgium, China, Japan, Korea

**GRACO INC. AND SUBSIDIARIES • P.O. BOX 1441 • MINNEAPOLIS MN 55440-1441 • USA
Copyright 2021, Graco Inc. All Graco manufacturing locations are registered to ISO 9001.**

www.graco.com
Revision L, September 2024