

Instructions



Electric Grease Jockey[®] Automatic Lubrication System

3A5082R

EN

For dispensing NLGI Grades #000 to #2 greases. For Professional Use Only.

Not approved for use in explosive atmospheres or hazardous locations.

Models: 24Z764, 24Z959, 24Z660, 23Z958, 26C494, 25V619

2000 psi (13.79 MPa, 137.9 bar)

Models: 26C495, 26A848, 2008338

1000psi (6.89 MPa, 68.9 bar)



Important Safety Instructions

Read all warnings and instructions in this manual before using the equipment. Be familiar with the proper control and usage of the equipment. Save these instructions.

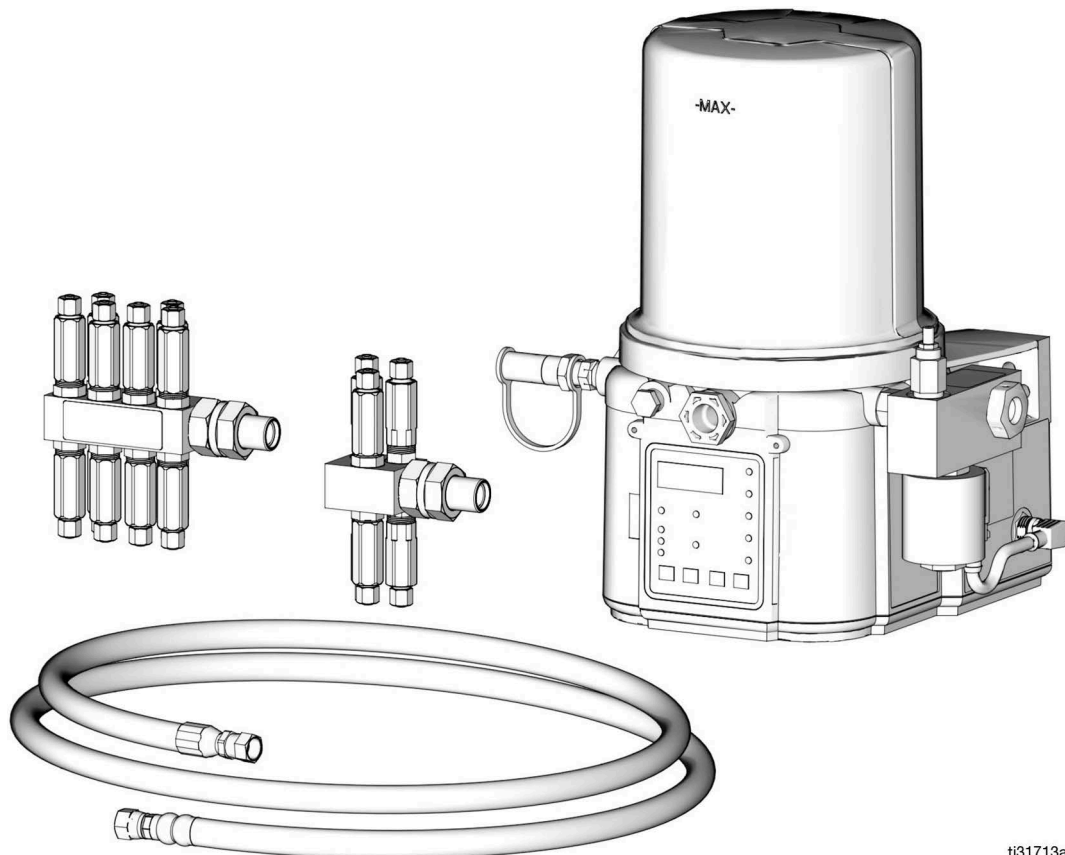









ti31713a









Contents

Safety Symbols	3	Manifold	54
General Warnings	4	Parts: 6 port models	54
Set Up	6	Parts: 12 port models	54
System Overview	6	Manifold Dimensions	55
Typical System Installation	7	Injector Manifold Assembly	55
Pump	9	Injectors	56
Component Identification	9	Parts	56
Parts	10	Injector Dimensions	56
Parts	11	Adjust the Grease Output Volume	57
Pump Dimensions	12	Manifold Installation	58
Select an Installation Location	13	Modules	59
Low Level Fault/Warning	18	Feed Line Tubes and Fittings	66
Fuses	18	Feed Line Tubes (H)	66
Pump Over-Current Protection	19	Feed Line Installation	66
Illuminated Remote Run Button	19	Feed Line Fittings	67
Tri-Color Remote Illumination	20	Main Line Hose	68
Direct Mount Vent Valve	22	Determine the Main Line Hose Lengths	68
Pump Setup	23	Main Line Hose Assembly	69
Prime the Pump	24	Main Line Fittings	71
Program the Pump	25	Start the System and Operation	72
Quick Setup Guide - DMS and Illuminated		Start the System	72
Remote Run Models	26	Operation	72
Pump Software	26	Troubleshooting	74
PUMP OFF / REST Setup	31	Maintenance	77
DMS™ Models	31	Service Parts	78
Error Log	35	Technical Specifications	82
Functional Summary	37	California Proposition 65	83
Technical Summary	38	Graco ILE On-Road Electric Grease Jockey	
Time Control	44	(EGJ) Warranty	84
Alarms	47	Graco Information	84
Fault and Warning Scenarios	47		
Additional Fault/Warning Scenarios for			
Firmware Versions 5.06 and Later for			
Non-DMS Models and 7.09 and later for			
DMS Models	52		
Testing Installation	53		
Manual Run Cycle	53		

Safety Symbols

The following safety symbols appear throughout this manual and on warning labels. Read the table below to understand what each symbol means.

Symbol	Meaning
	Cleaning Solvent Hazard
	Electric Shock Hazard
	Equipment Misuse Hazard
	Fire and Explosion Hazard
	Moving Parts Hazard
	Skin Injection Hazard
	Skin Injection Hazard
	Skin Injection Hazard

Symbol	Meaning
	Splash Hazard
	Do Not Place Hands or Other Body Parts Near Fluid Outlet
	Do Not Stop Leaks with Hand, Body, Glove or Rag
	Consult Doctor
	Follow Pressure Relief Procedure
	Ground Equipment
	Read Manual
	Wear Personal Protective Equipment











Safety Alert Symbol







This symbol indicates: Attention! Become Alert! Look for this symbol throughout the manual to indicate important safety messages.

General Warnings

The following warnings apply throughout this manual. Read, understand, and follow the warnings before using this equipment. Failure to follow these warnings can result in serious injury.

 <h1 style="margin: 0;">WARNING</h1>	
 	<p>EQUIPMENT MISUSE HAZARD Misuse can cause death or serious injury.</p> <ul style="list-style-type: none"> Do not operate the unit when fatigued or under the influence of drugs or alcohol. Do not exceed the maximum working pressure or temperature rating of the lowest rated system component. See Technical Specifications in all equipment manuals. Use fluids and solvents that are compatible with equipment wetted parts. See Technical Specifications in all equipment manuals. Read fluid and solvent manufacturer’s warnings. For complete information about your material, request Safety Data Sheets (SDSs) from distributor or retailer. Turn off all equipment and follow the Pressure Relief Procedure when equipment is not in use. Check equipment daily. Repair or replace worn or damaged parts immediately with genuine manufacturer’s replacement parts only. Do not alter or modify equipment. Alterations or modifications may void agency approvals and create safety hazards. Make sure all equipment is rated and approved for the environment in which you are using it. Use equipment only for its intended purpose. Call your distributor for information. Route hoses and cables away from traffic areas, sharp edges, moving parts, and hot surfaces. Do not kink or over bend hoses or use hoses to pull equipment. Keep children and animals away from work area. Comply with all applicable safety regulations.
    	<p>SKIN INJECTION HAZARD High-pressure fluid from dispensing device, hose leaks, or ruptured components will pierce skin. This may look like just a cut, but it is a serious injury that can result in amputation. Get immediate surgical treatment.</p> <ul style="list-style-type: none"> Do not point dispensing device at anyone or at any part of the body. Do not put your hand over the fluid outlet. Do not stop or deflect leaks with your hand, body, glove, or rag. Follow the Pressure Relief Procedure when you stop dispensing and before cleaning, checking, or servicing equipment. Tighten all fluid connections before operating the equipment. Check hoses and couplings daily. Replace worn or damaged parts immediately.

WARNING

 	<p>PLASTIC PARTS CLEANING SOLVENT HAZARD</p> <p>Many cleaning solvents can degrade plastic parts and cause them to fail, which could cause serious injury or property damage.</p> <ul style="list-style-type: none"> • Use only compatible solvents to clean plastic structural or pressure-containing parts. • See Technical Specifications in all equipment manuals for materials of construction. Consult the solvent manufacturer for information and recommendations about compatibility.
 	<p>PRESSURIZED EQUIPMENT HAZARD</p> <p>Fluid from the equipment, leaks, or ruptured components can splash in the eyes or on skin and cause serious injury.</p> <ul style="list-style-type: none"> • Follow the Pressure Relief Procedure when you stop spraying/dispersing and before cleaning, checking, or servicing equipment. • Tighten all fluid connections before operating the equipment. • Check hoses, tubes, and couplings daily. Replace worn or damaged parts immediately.
 	<p>MOVING PARTS HAZARD</p> <p>Moving parts can pinch, cut or amputate fingers and other body parts.</p> <ul style="list-style-type: none"> • Keep clear of moving parts. • Do not operate equipment with protective guards or covers removed. • Equipment can start without warning. Before checking, moving, or servicing equipment, follow the Pressure Relief Procedure and disconnect all power sources.
	<p>PERSONAL PROTECTIVE EQUIPMENT</p> <p>Wear appropriate protective equipment when in the work area to help prevent serious injury, including eye injury, hearing loss, inhalation of toxic fumes, and burns. Protective equipment includes but is not limited to:</p> <ul style="list-style-type: none"> • Protective eyewear, and hearing protection. • Respirators, protective clothing, and gloves as recommended by the fluid and solvent manufacturer.

Set Up

Grease Fittings

- Lubricate all of the grease fittings with a grease gun and verify every grease point accepts grease.
- Use a clean cloth or rag to remove any extra grease, contaminants or dirt from the area around the passage way to the grease points.
- Remove the grease fittings and extensions and then install the appropriate feed line fitting.

System Overview

The Electric Grease Jockey Automatic Lubrication System includes the following components. The numbers and letters used in these instructions refer to **Typical System Installation**, page 7, and to the component pages listed:

- **Pump**, page 9
- **Illuminated Remote Run Button**, page 19
- **Direct Mount Vent Valve**, page 22
- **Manifold**, page 54
- **Injectors**, page 56
- **Modules**, page 59
- **Feed Line Tubes and Fittings**, page 66
- **Main Line Hose**, page 68

Pressure Relief Procedure



Follow the Pressure Relief Procedure whenever you see this symbol.



This equipment stays pressurized until pressure is manually relieved. To help prevent serious injury from pressurized fluid, such as skin injection, splashing fluid and moving parts, follow the Pressure Relief Procedure when you stop dispensing and before cleaning, checking, or servicing the equipment.

Relieve pressure in system using two wrenches working in opposite directions on the banjo bolt (A) and outlet fitting to slowly loosen fitting only until fitting is loose and no more lubricant or air is leaking from fitting.

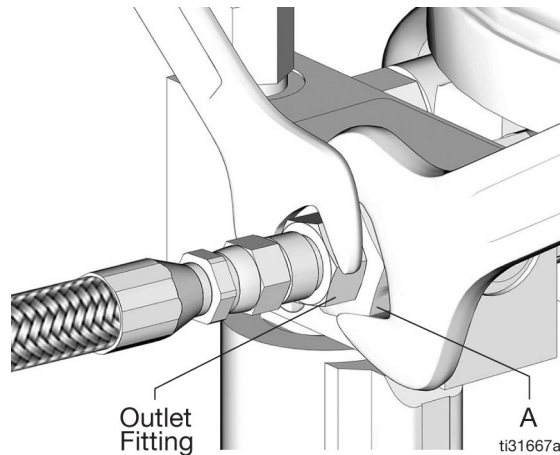

FIG. 1

Typical System Installation

The installations shown in FIG. 2 and FIG. 3 are only guides for selecting and installing system components and accessories. Contact your Graco distributor for assistance in designing a system.

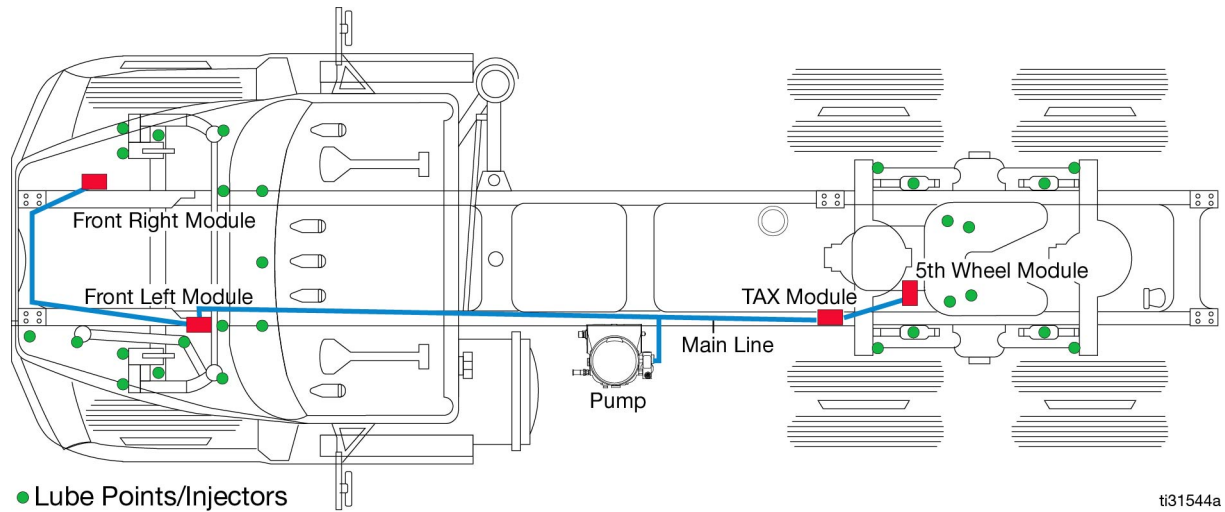

FIG. 2

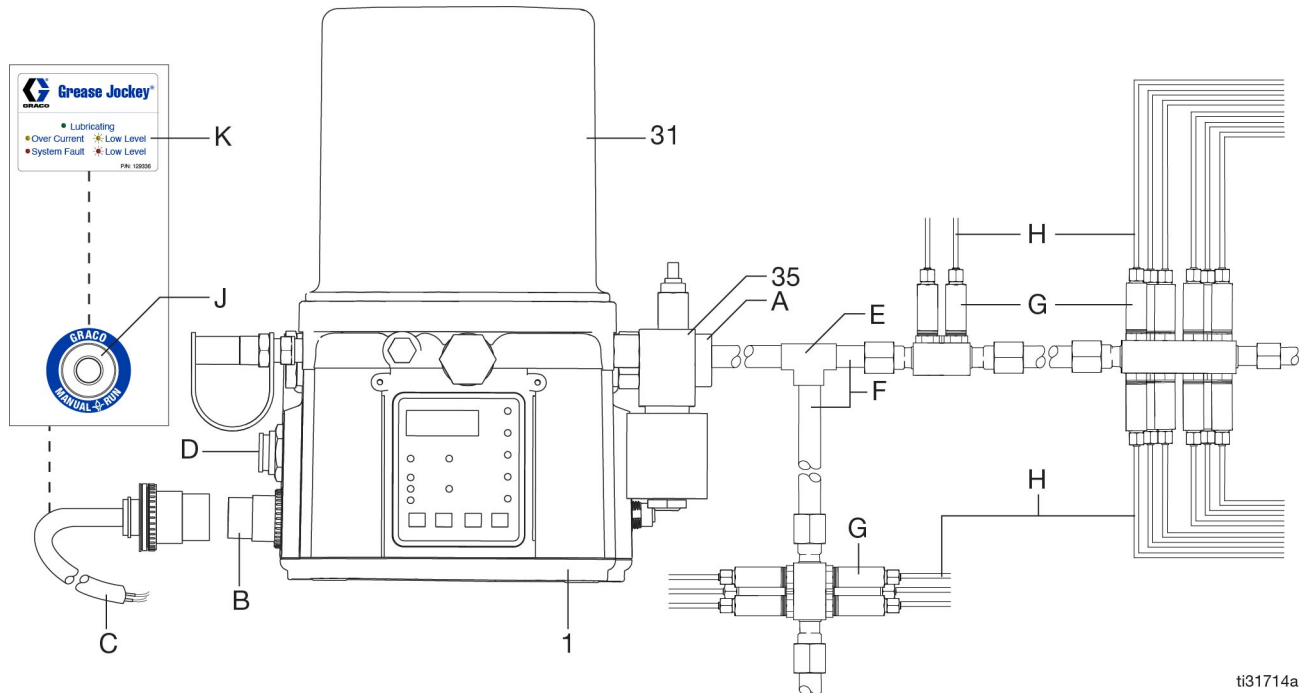
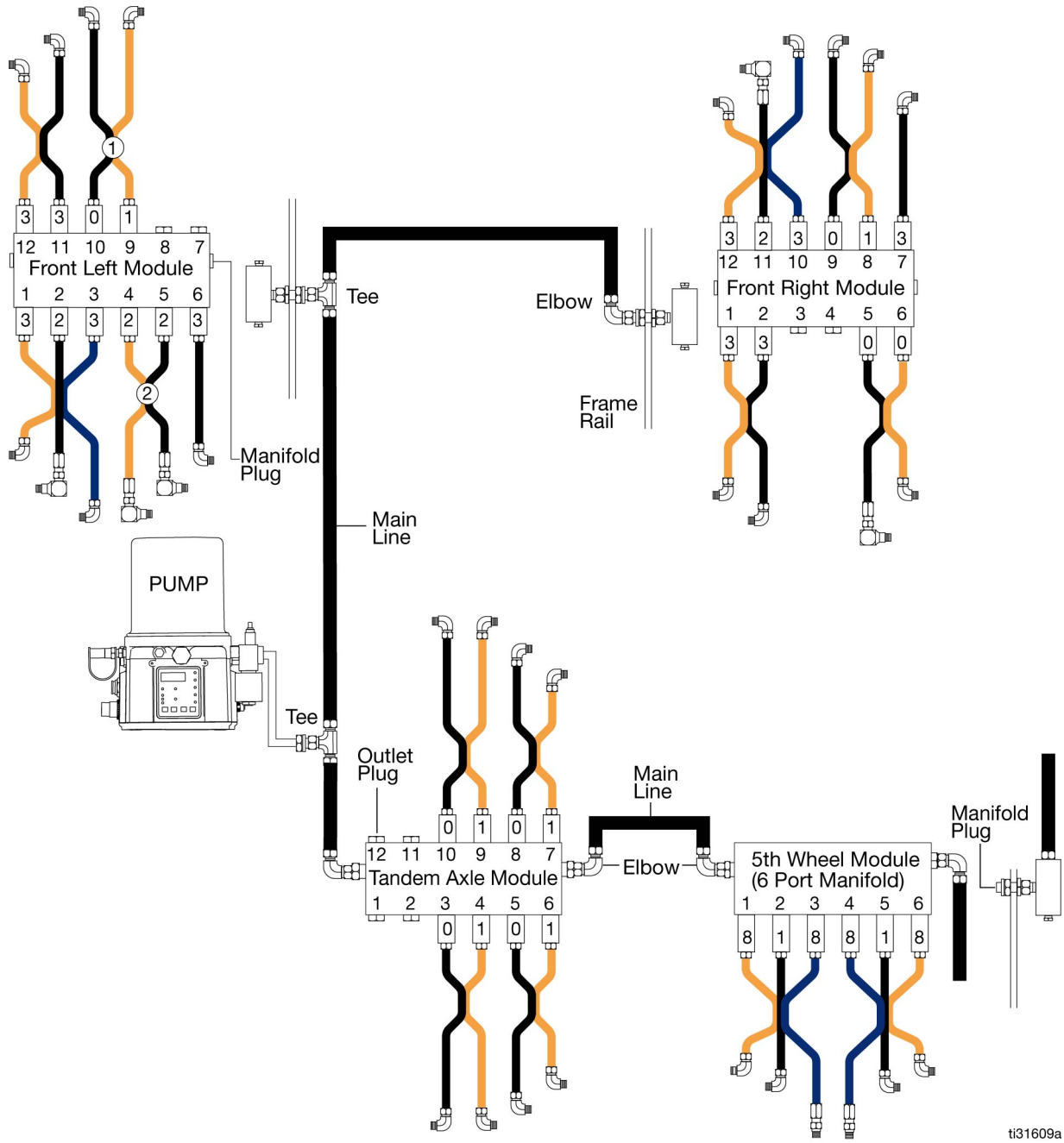

FIG. 3

Key:

- | | |
|--|--|
| A Banjo Bolt / Pump Outlet | H Feed Line Tubes |
| B Power Connector | J Manual Run Button (located in truck cab) |
| C Power Cable / Remote Run Button Cable | K Instruction Label (located in truck cab) |
| D USB Port (DMS™ Models Only) | |
| E T-Fitting - Pump to Main Feed Hose (M) | 1 Pump |
| F Main Feed Hose | 31 Reservoir |
| G Injectors / Modules | 35 Vent Valve Assembly |

Typical System Installation



ti31609a

FIG. 4

Pump

Component Identification

Part No:

24Z764: 12 V Standard

24Z959: 24 V Standard

26C494: 12 V, DMS with follower

26C495: 12 V Standard 1000 psi

24Z660: 12 V, DMS and Illuminated Remote Run Button Capable

24X958: 24 V, DMS and Illuminated Remote Run Button Capable

26A848: 24 V, DMS and Illuminated Remote Run Button Capable 1000 psi

25V619: 12 V, Telematic Outputs, Pressure Feedback, and Illuminated Remote Run Button Capable, 2000 psi

2008338: 12 V, Telematic Outputs, Pressure Feedback, and Illuminated Remote Run Button Capable, 1000 psi

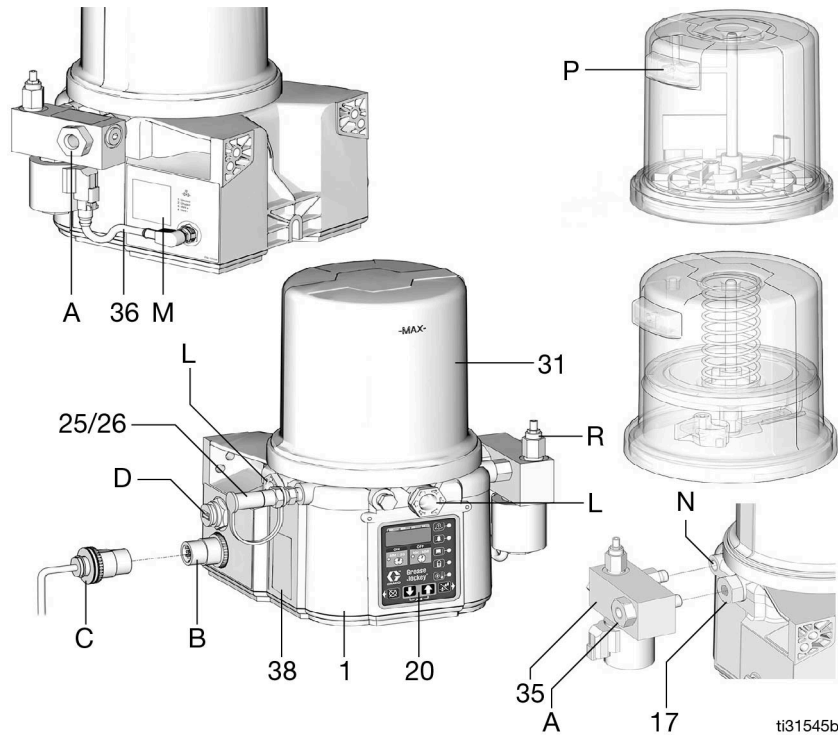

FIG. 5

Key:

- | | |
|--|---|
| A Banjo Bolt / Pump Outlet | 1 Pump |
| B CPC Power Connector | 17 Pump Element (one included, can accommodate three total) |
| C Power Cable / Remote Run Button Cable (required, sold separately) | 20 Control Panel |
| D USB Port (DMS™ Models only), or Pressure Switch (Telematic Model only) | 25 Inlet Fill Filling (fill port) |
| L Pump Outlet Plug | 26 Dust Cap |
| M Part No. Label | 31 Reservoir |
| N Vent Hold | 35 Vent Valve Assembly |
| P Air Vent for Reservoir | 36 Vent Valve Cable |
| R Relief Valve | 38 Safety Label, Pressure Warning |

Parts

Models: 24Z660, 24Z958, 24Z764, 24Z959, 26C494, 26C495, 26A848, 25V619, 2008338

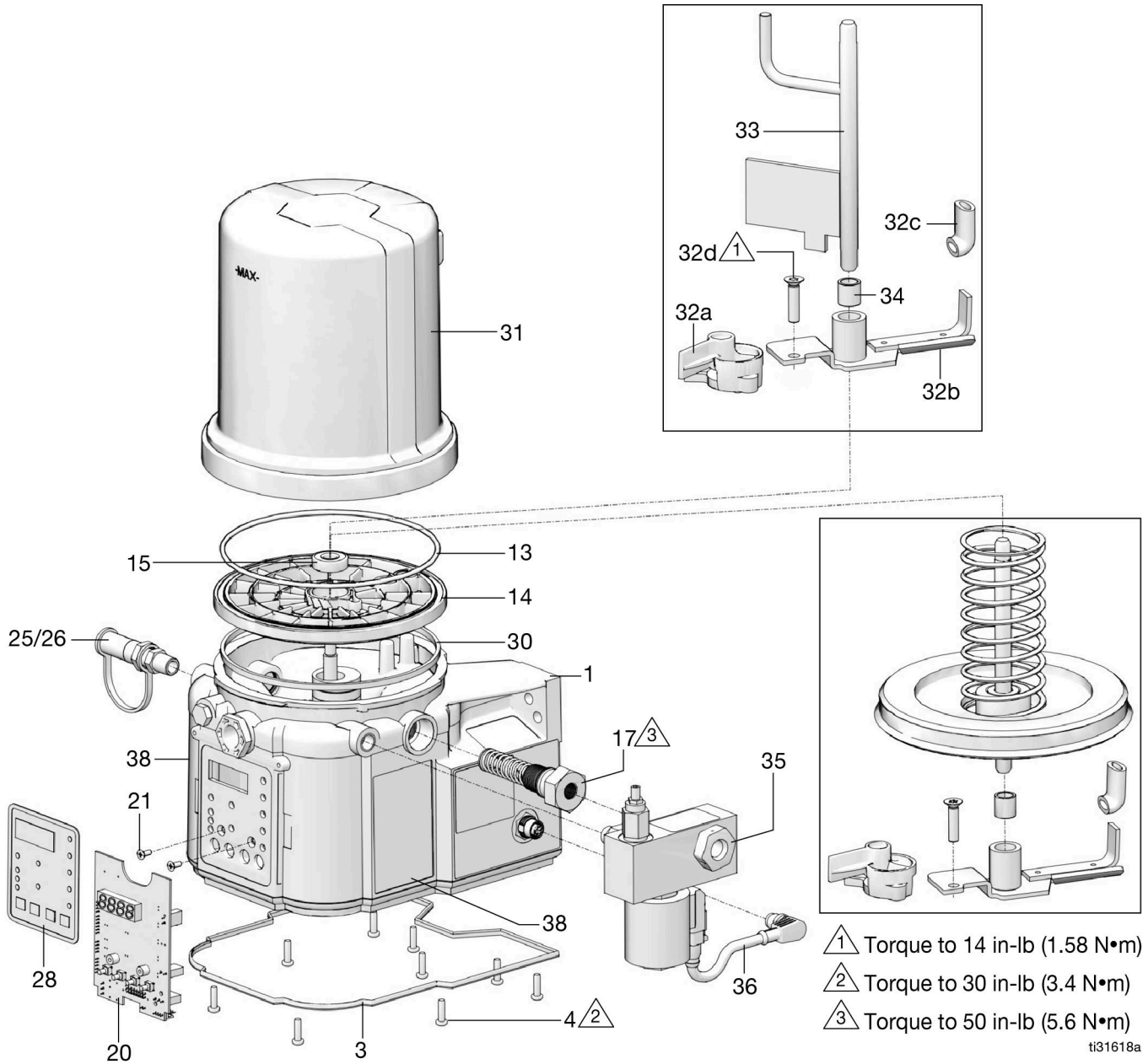

FIG. 6

Parts

Models: 24Z660, 24Z958, 24Z764, 24Z959, 26C494, 26C495, 26A848, 25V619, 2008338

Ref	Part	Description	Qty
1		BASE, with control	1
3	278142	COVER, bottom, w/seal	1
4	115477	SCREW, mach, orx pan hd	9
13❖	124396	O-RING, 258, BUNA-N, green	1
14		PLATE, ricer	1
15		BEARING, ball	1
17	25C987	PUMP, element	1
20†	24T872	BOARD, circuit, standard models	1
20†	262463	BOARD, circuit, DMS models	1
20†	258697	BOARD, circuit (Telematic models)	1
21	119228	SCREW, mach, flat hd	2
25	557874	STUD, fill 1/4 NPTF female	1
26	557875	CAP, dust 3/4	1
28	129379	LABEL, overlay	1
30❖	127079	PACKING, Rect-ring, 258 BUNA-N	1
31❖	571075	RESERVOIR, 2 liter, with follower (26C494 only)	1
	24Z528	RESERVOIR, 2 liter, GJ,	1
32	24P108	PLATE, wiper arm follow	1
32a		PADDLE, low level	1
32b		PADDLE, stirring	1
32c		WIPER, stirring	1
32d		SCREW, M6	1
32e		WASHER	2
33◆	24D838	BAFFLE, low level, 2L	1
34	117156	BEARING, sleeve	1
35	25C965	VALVE, VENT, 12 VDC, DEU, N.O.	1
	25C966	VALVE, VENT, 24 VDC, DEU, N.O.	1
	26C493	VALVE, VENT, 12 VDC, DEU, N.O. 1000 psi	1
	26A856	VALVE VENT, 24 VDC, DEU, N.O. 1000 PSI	1
36	129801	CABLE, M12 X DEUTSCH	1
38▲	16A579	LABEL, safety, warning, pressure	2

▲ Replacement safety labels, tags, and cards are available at no cost

❖ Included in Kit 25V122

† Also order Screw (21) and Label (28).

◆ Also order Bearing Sleeve (34)

Pump Dimensions

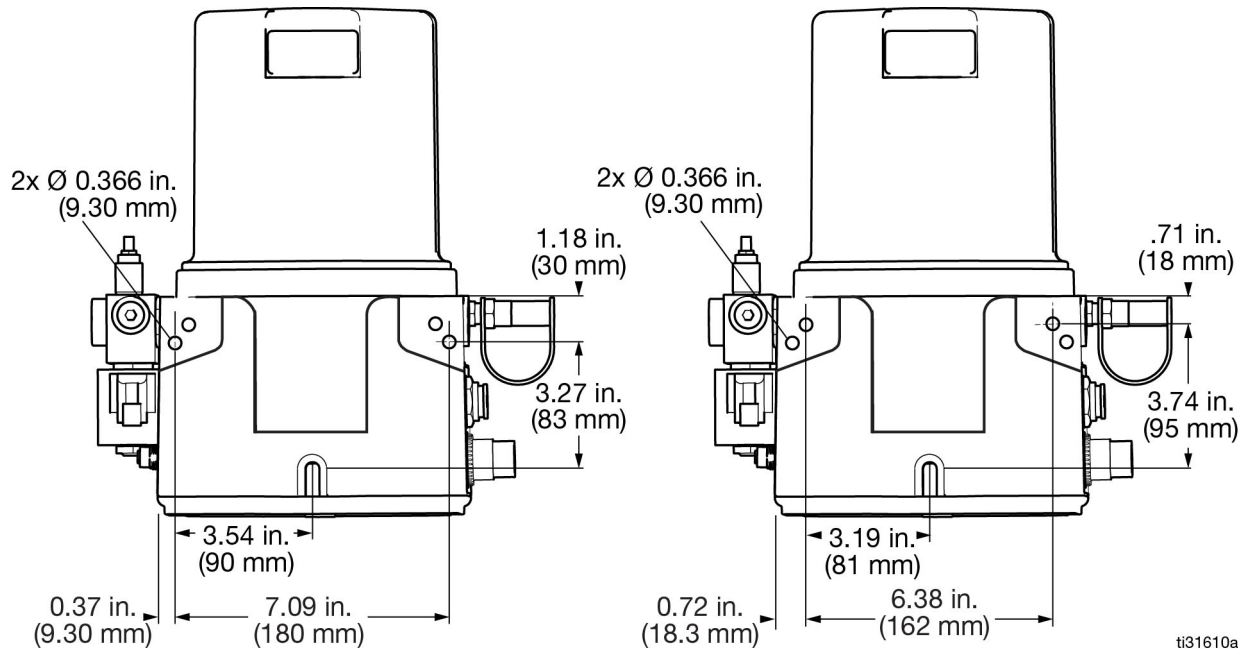
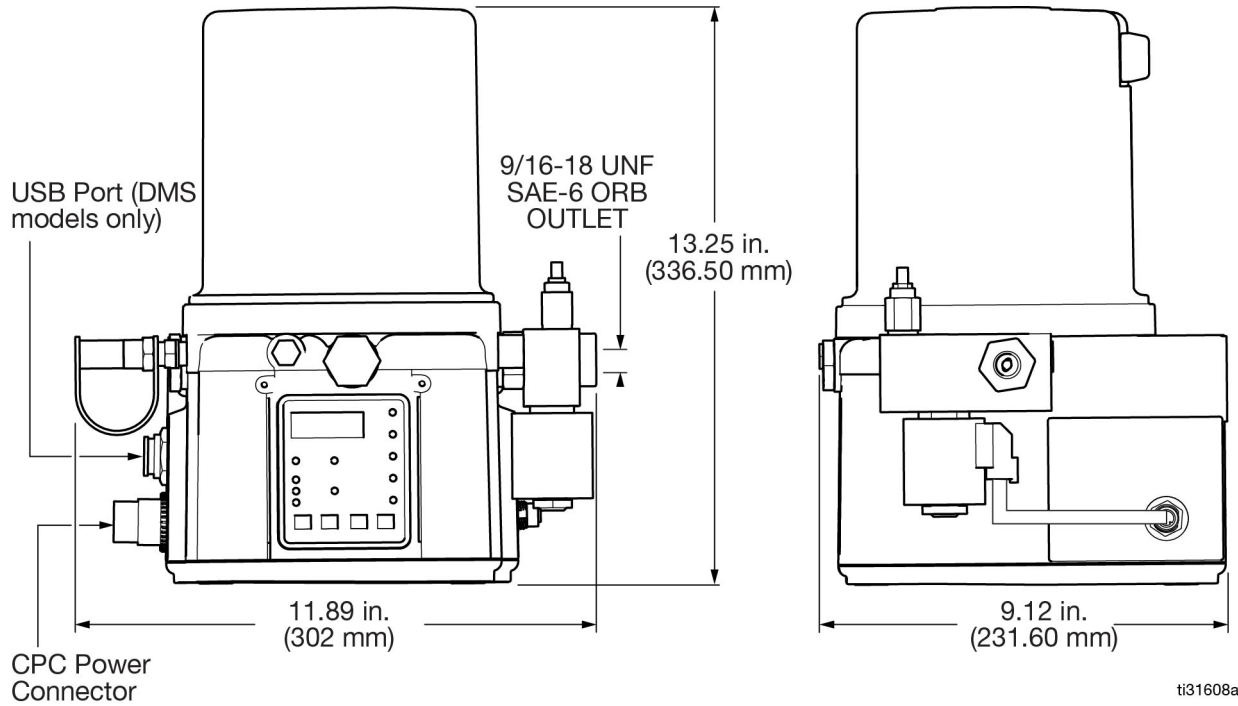

FIG. 7

Select an Installation Location

- Select a location that adequately supports the weight of the pump and lubricant, as well as all plumbing and electrical connections.

NOTE: The mounting hardware (user supplied) must be strong enough to support the weight of the pump, lubricant, and all plumbing and electrical connections.

- Mount the pump in a location that allows for easy access to the pump controls and fill port.
- Mount the pump in a location that protects from common hazards that could damage the pump. Consider all road hazards the pump may be exposed to when selecting a mounting location.
- Do not mount the pump near the Diesel Exhaust Fuel (DEF) exhaust pipe.
- Use mounting brackets to secure the pump directly to either the outside or inside of the lower truck frame. Torque fasteners to 165 ft-lb (223.7 N•m), as shown in FIG. 8 to FIG. 11.
- Secure the power cable to the mounting brackets with panel mounts and zip ties.

NOTE: Mounting brackets (Part Nos. 25T767 and 25T567) are suitable for mounting on most truck frames, and are available from Graco. Contact your local Graco distributor for assistance with ordering this part. See FIG. 12, page 15 for bracket with pump dimensions.

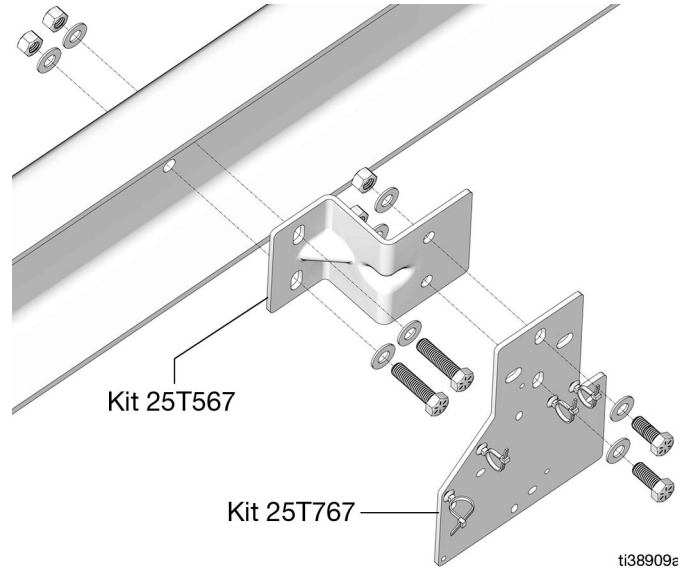

FIG. 8: Inside Truck Frame Mount Installation (Kits 25T567 and 25T767)

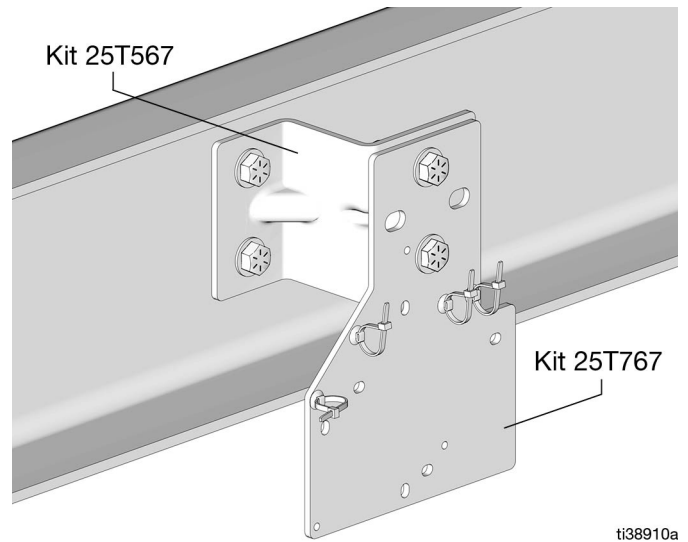
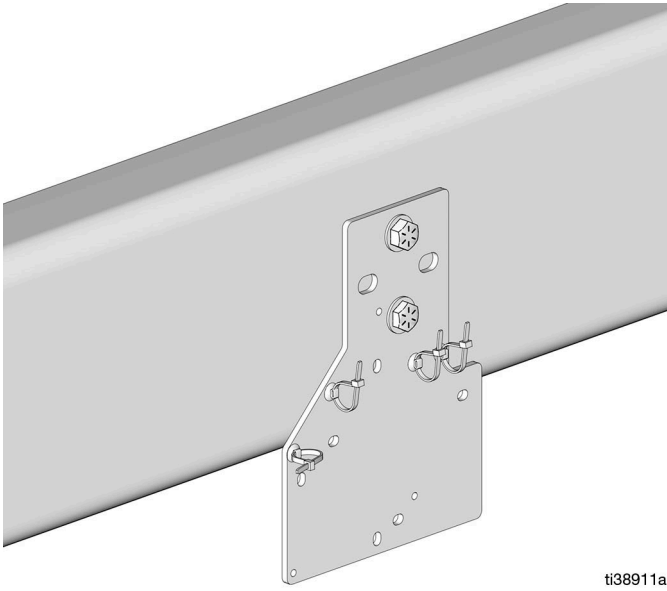

FIG. 9: Inside Truck Frame Mount Installation (Kits 25T567 and 25T767)

Pump



ti38911a

**FIG. 10: Outside Truck Frame Mount Installation
(Kit 25T767)**

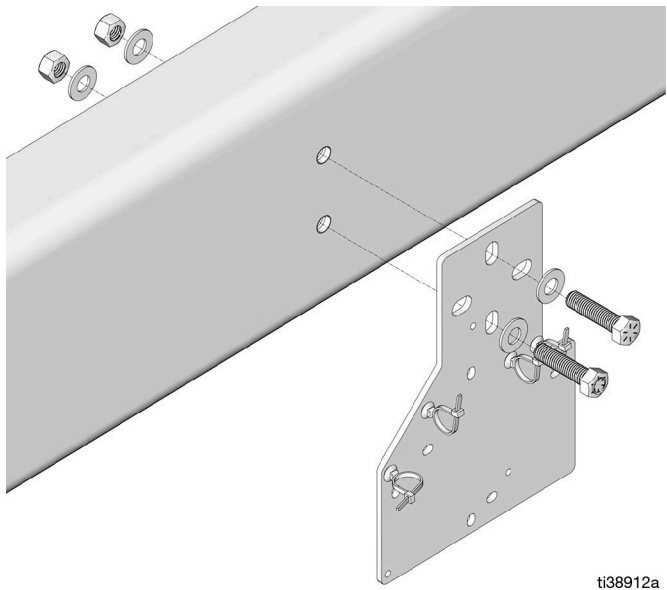

ti38912a

**FIG. 11: Outside Truck Frame Mount Installation
(Kit 25T767)**

Mounting Bracket and Pump Dimensions

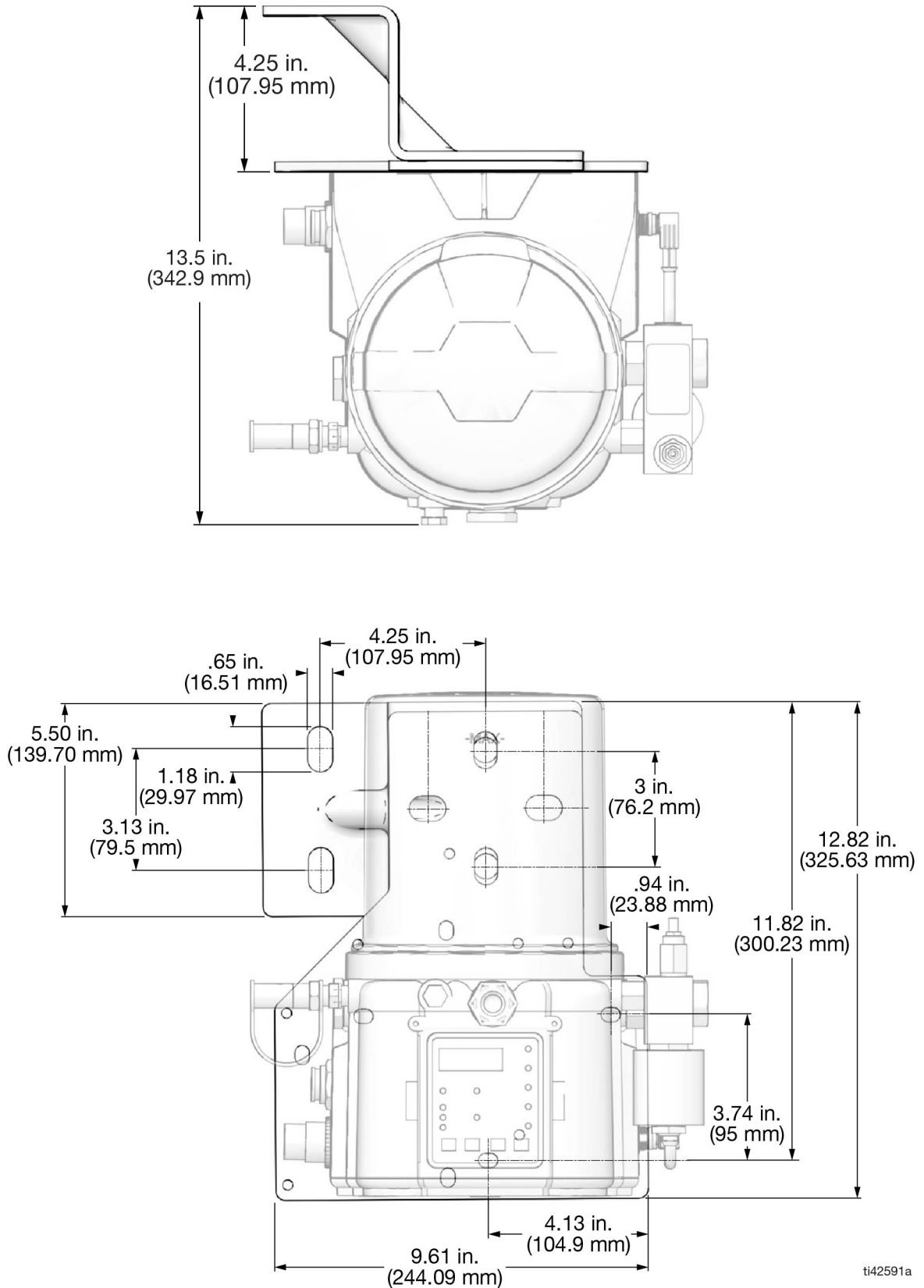

ti42591a

FIG. 12

Pump Wiring Diagram (Standard Models: 24Z764, 24Z959, 26C494, AND 26C495)

The pump requires a 2-wire, CPC Connector Cable (Part No. 129644) to power the pump. See the Wiring Schematic provided in FIG. 13.

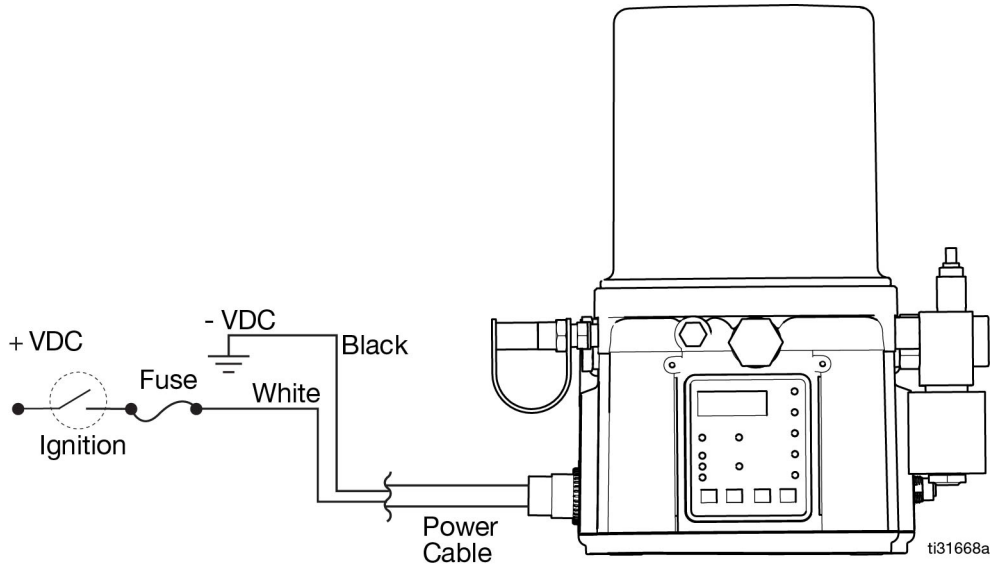

FIG. 13

Pump Wiring Diagram (Models with DMS and Illuminated Remote Run Button: 24Z660, 24Z958, 26C494 AND 26A848)

The pump requires a 5-wire, CPC Connector Cable (Part No. 2003896) to power the pump and illuminated remote run button. See the Wiring Schematic provided in FIG. 14.

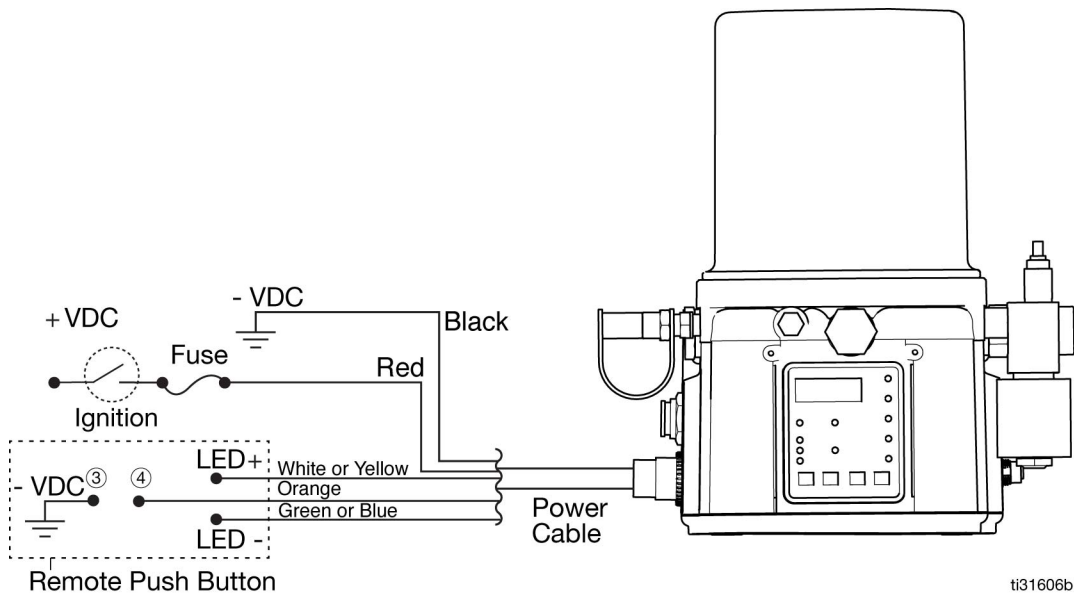

FIG. 14

Pump Wiring Diagram (Models with Telematic Outputs and Illuminated Remote Run Button: 25V619 and 2008338)

The pump requires a 5-wire, CPC Connector Cable (Part No. 2003896) to power the pump and illuminated remote run button. See the Wiring Schematic provided in FIG. 15.

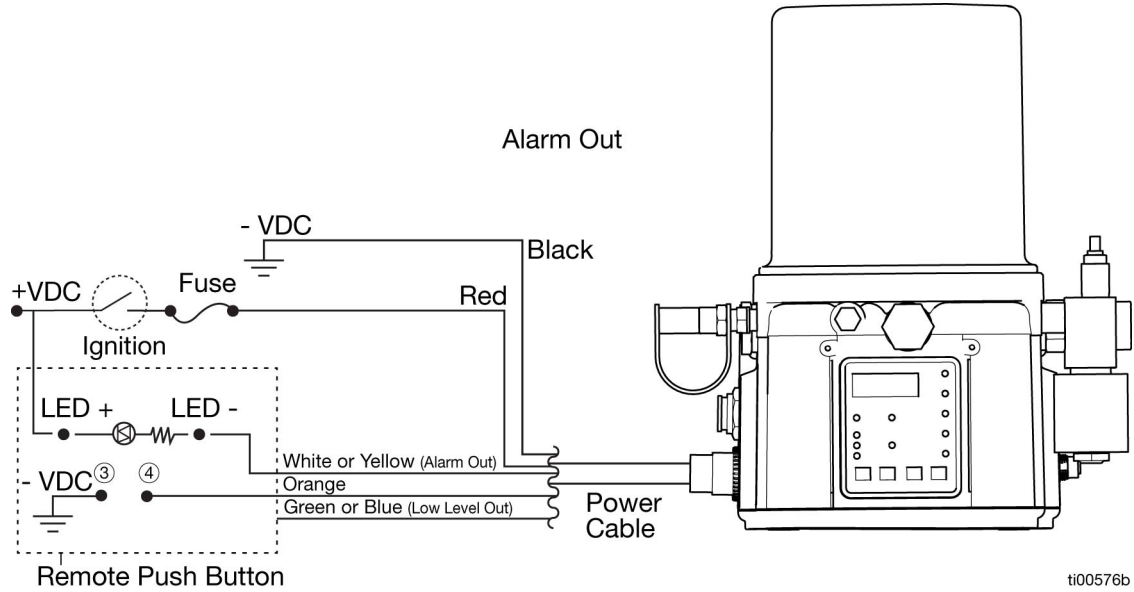

FIG. 15

Low Level Fault/Warning

When approximately 1 lubrication cycle remains, the yellow blinking warning light; the green, low level light illuminates, and Er:LL flashes on the display, as shown in FIG. 16. Fill the reservoir as soon as possible.



ti00076a

FIG. 16

If the pump reservoir is not refilled with grease, the pump stops. A red, blinking fault light; the green, low level light illuminates, and Er:LL appears on the display as shown in FIG. 17.

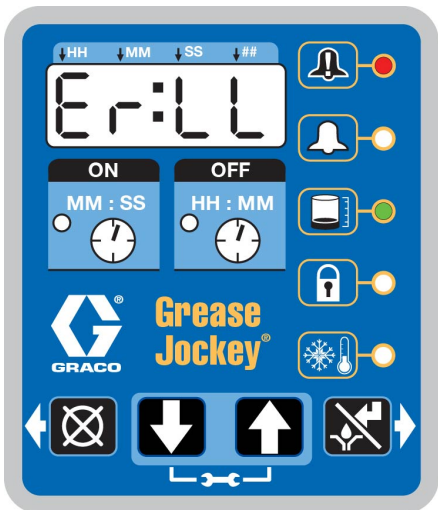

ti00077a

FIG. 17

Pumps with a remote run button (except for Models 25V619 and 2008338) indicate the low level warning and low level fault as shown on the Low Level Fault/Warning Table:

Low Level Fault/Warning Table

Warning or Fault	Illumination
Low Level Warning	Yellow blinking
Low Level Fault	Red blinking

Fuses

NOTICE

Fuses (user supplied) are required on all pump models. To avoid equipment damage:

- Never operate pump without a fuse installed.
- A fuse of the correct voltage must be installed in line with the power entry to the system.

Graco Fuses

Part No.	Description	Amps
25C985	12 VDC	10 Amps
25C986	24 VDC	7.5 Amps

Pump Over-Current Protection

The pump has built-in over-current protection to protect the motor. In cold weather installations, if the grease freezes, the motor draws more current. The motor attempts to start the pump 90 times before it shuts down.

How Over-Current Protection Works

When the pump is unable to start the ON Time cycle, an over-current condition is created:

- a. The pump immediately goes into OFF Time.
- b. At the end of OFF Time, the pump attempts to run the ON Time cycle. One of two results are possible at this point:
 - The pump runs the scheduled ON Time cycle, and normal cycle operation begins.
 - The pump is not able to start (the condition is still over-current) and immediately goes into programmed OFF Time. This repeats 90 times before it shuts down.

Illuminated Remote Run Button

Available on DMS enabled models and Telematic options only.

Parts:

25C981: 12VDC

25C982: 24 VDC

571031: 12 VDC Telematic*

Ref	Part No.	Description	Qty
51		Push button	1
52		Connector	4
53		Button Label	1
54		O-ring	1
55	129336	Cab Information Label	1

*Button Label not included

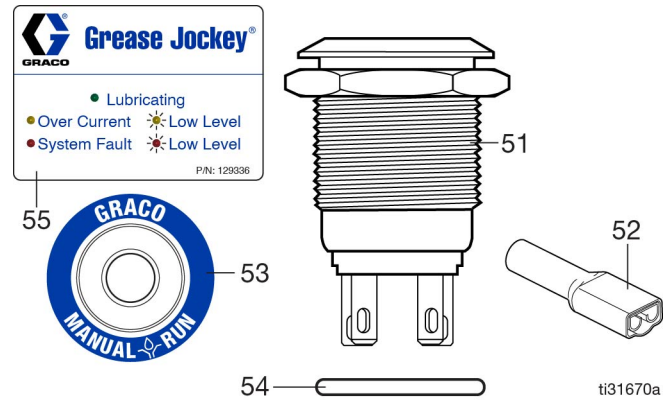
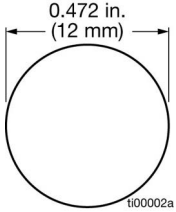

FIG. 18

Installation

Install the remote run button in an easily accessible location inside of the truck cab.

1. Drill a hole in the panel. The illustration on the right shows the cutout dimension. The maximum panel thickness is 0.472 in./12.0 mm.
 
2. Remove the lock nut (51a) from the push button (51). Install the o-ring (54) (FIG. 19).
3. Insert the push button (51) through the hole drilled in the panel in Step 1. Hand tighten the lock nut (1a) to secure the push button in place (FIG. 19).

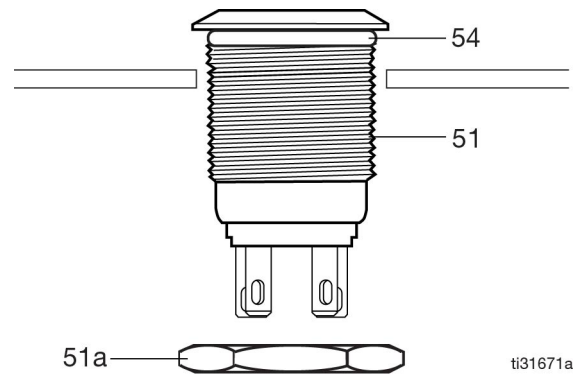

FIG. 19

Pump

- Clean the surface around the outer edge of the push button (51). Position label (53) around the button and adhere label (FIG. 20).

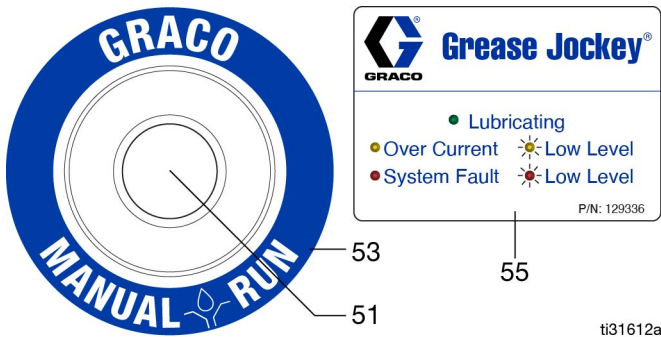
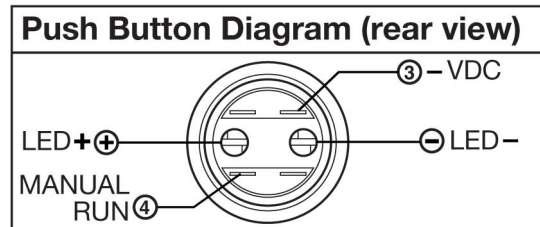
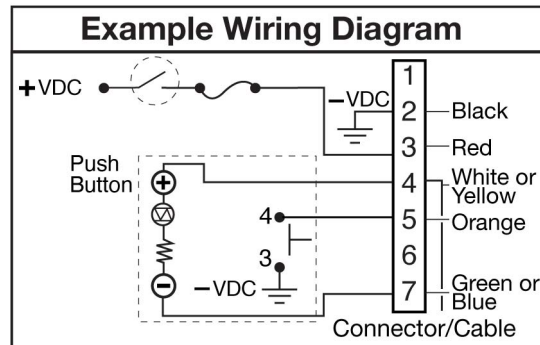
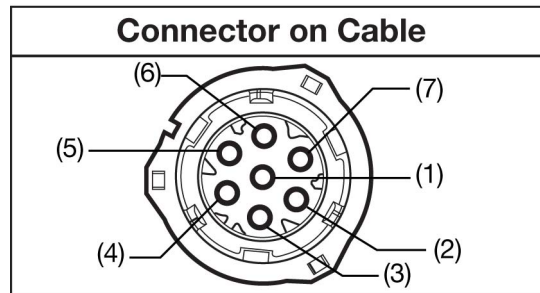
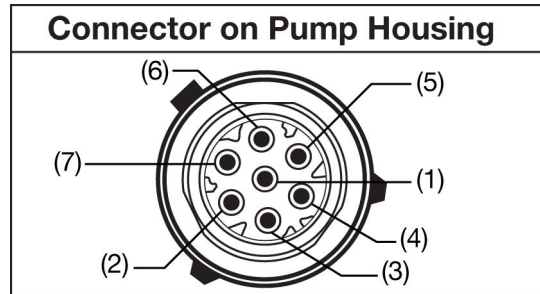

FIG. 20

- Clean the area close to the push button for mounting the label (55) inside of the cab. Adhere label to the mounting surface.
- Connect the wiring connector (52) to the push button and the pump. See **Pin and Related Wire Color (FIG. 21)** and the wiring information shown in FIG. 21.

Pin and Related Wire Color (FIG. 21)
(24Z660, 24Z958, 24Z764, 24Z959, 25C494, 25C495)

Pin	Pin Name	Color
1	Not Used	Not Used
2	-VDC	Black
3	+VDC	Red
4	LED+	White or Yellow
5	Manual Run Switch	Orange
6	Not Used	Not Used
7	LED-	Green or Blue



ti30228b

FIG. 21

Tri-Color Remote Illumination

	Tri-Color Remote Illumination
Pump in OFF Mode	No indication
Pump in ON Mode	Green - ON
Low Level Warning	Yellow - Toggles ON and OFF once per second
Over-current Warning Condition	Yellow
Low Level Fault	Red - Toggles ON and OFF once per second
System Fault	Red

Pin and Related Wire Color (FIG. 22)
(25V619 and 2008338)

Pin	Pin Name	Color
1	Not Used	Not Used
2	-VDC	Black
3	+VDC/LED+	Red
4	LED-/Alarm Out	White or Yellow
5	Manual Run Switch	Orange
6	Not Used	Not Used
7	Low Level Out	Green or Blue

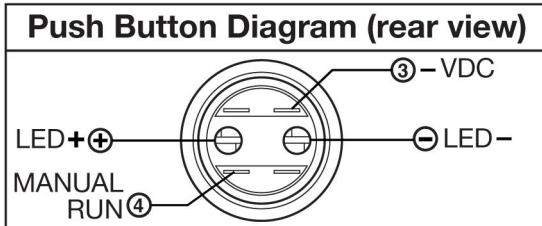
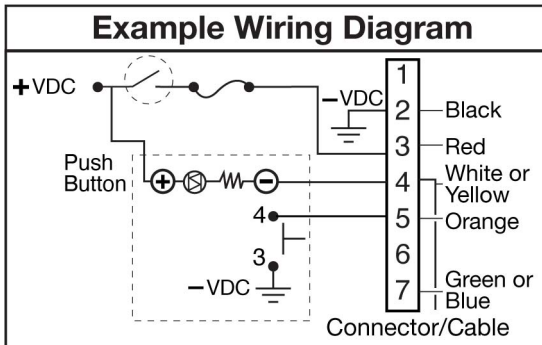
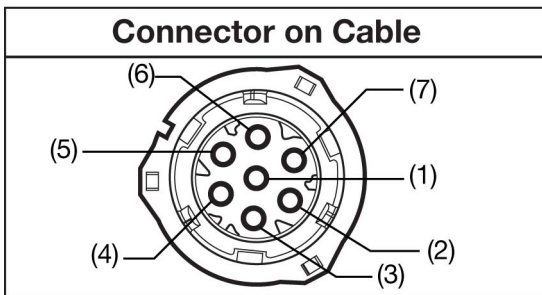
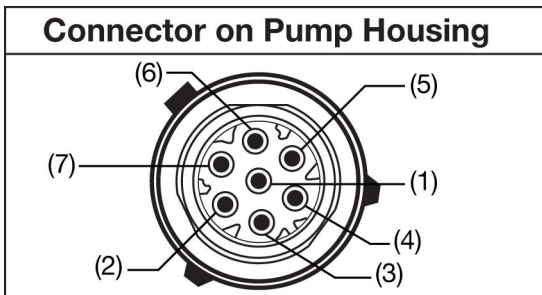

ti00577b

FIG. 22



Inputs (M12)

See **Technical Specifications**, page 82 for ratings.

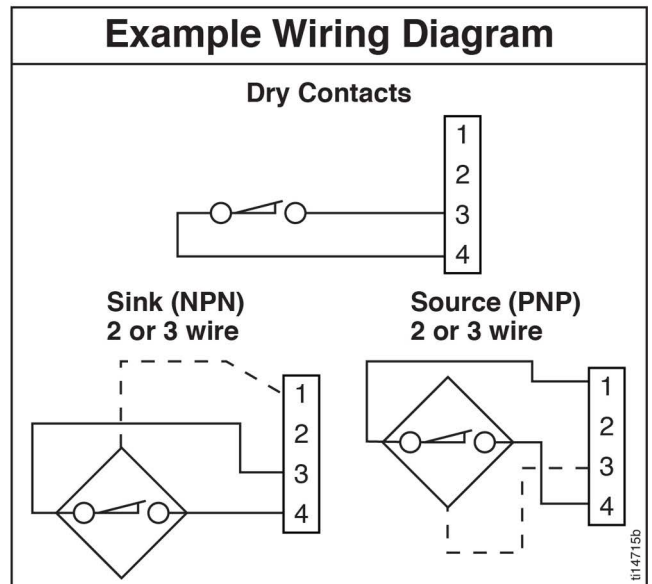
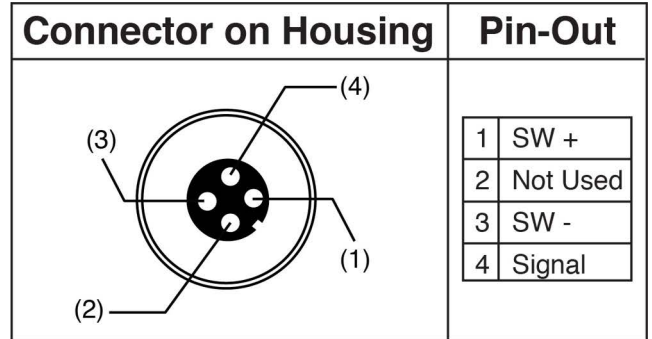
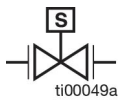

FIG. 23

Direct Mount Vent Valve

The Direct Mount Vent Valve is installed on the pump when shipped. Vent Valve Replacement Kits 25C965 (2000 psi) and 26C493 (1000 psi) for 12 Volt pumps and 25C966 (2000 psi) and 26A856 (1000 psi) for 24 Volt pumps are available from Graco. Contact your local Graco Distributor or Graco Customer Service for assistance when ordering this part.



Connect one end of the vent valve cable (36) (Graco Part No. 129801) to the vent valve connector on the pump. Connect the other end of the cable to the vent valve (35) (Fig. 24).

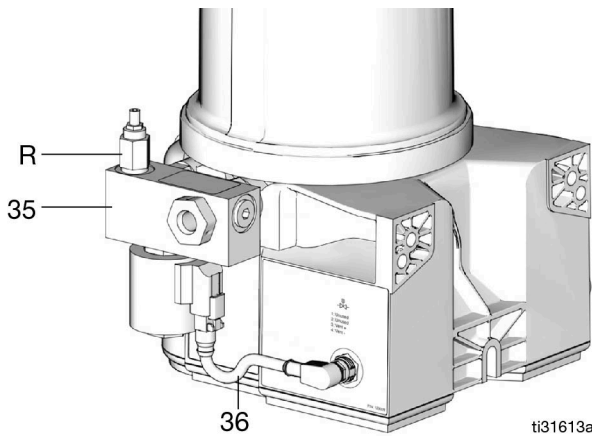

FIG. 24

Vent Valve Outputs

See **Technical Specifications**, page 82 for ratings.

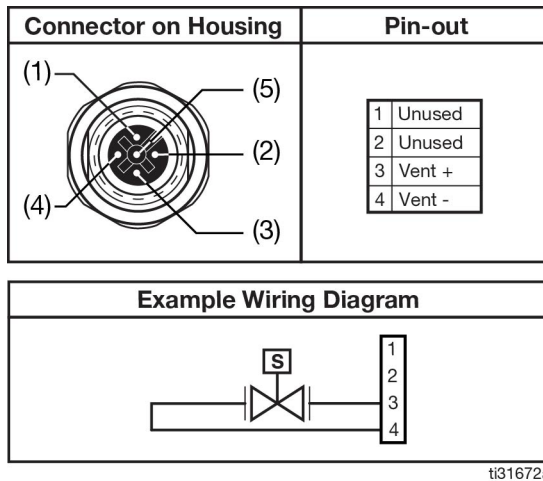

FIG. 25

Pressure Relief Valve (R) (FIG. 24)

The pressure relief valve is preset to 1000 psi (6.895 MPa, 68.95 bar) or 2000 psi (13.79 MPa, 137.9 bar).

NOTE: Do not adjust this setting. Adjusting the pressure relief valve to decrease pressure may negatively impact on the performance of the pump or the lubrication system.

SKIN INJECTION HAZARD				
Adjusting the pressure relief valve to increase the pressure may result in hose leaks or ruptured components which could result in a serious skin injection injury.				

Pump Setup

Fill the Reservoir

To ensure optimal performance from the pump:

- Only use NLGI #000 - #2 greases appropriate for the application, automatic dispensing, and the operating temperature of the equipment. Consult with machine and lube manufacturer for details.
- The reservoir can be filled using a pneumatic pump or electric transfer pump.
- Do not fill above the maximum fill line (FIG. 27).
- Do not operate without the reservoir attached.

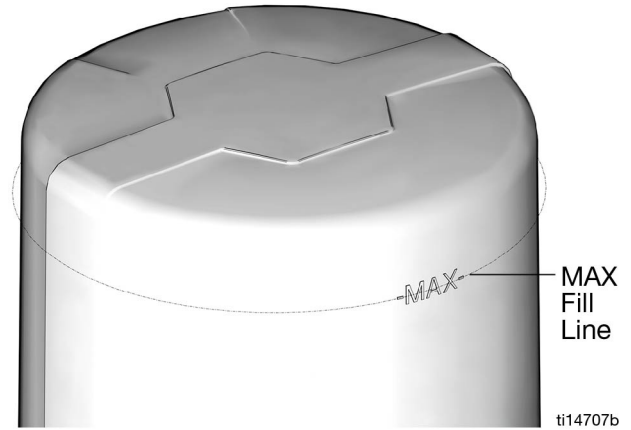

FIG. 27

NOTE: The reservoir air vent (P), located at the rear of the reservoir, should not be used as an overfill port/indicator (FIG. 28).

NOTICE
<ul style="list-style-type: none"> • Always clean inlet fitting (25) (FIG. 26) with a clean dry cloth prior to filling reservoir. Dirt and/or debris can damage pump and/or lubrication system. • Care must be used when filling the reservoir using a pneumatic or electric transfer pump to not pressurize and break the reservoir.

1. Remove dust cap (26) and connect the fill hose to the inlet fitting (25) (FIG. 26).

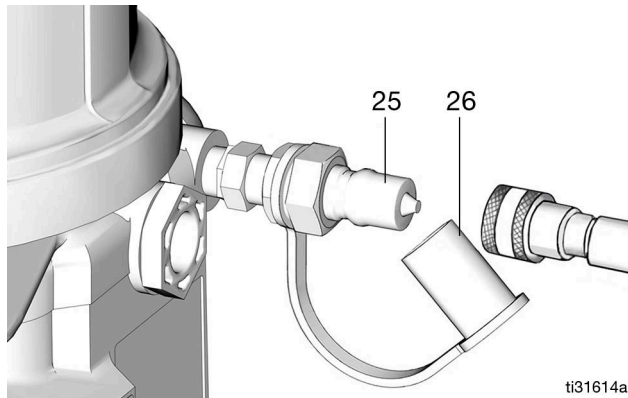

FIG. 26

2. For higher viscosity fluids, start the pump to rotate the stirring paddle while being filled to prevent air pockets from forming in the grease.

To start the pump, press the manual run button.



3. Fill reservoir to the max fill line (FIG. 27).

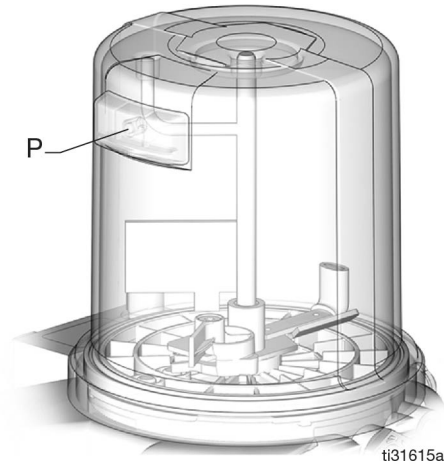

FIG. 28

4. When the grease has reached the max fill line (FIG. 27, page 23), remove the fill hose and replace the dust cap (26) over the inlet fitting (25).

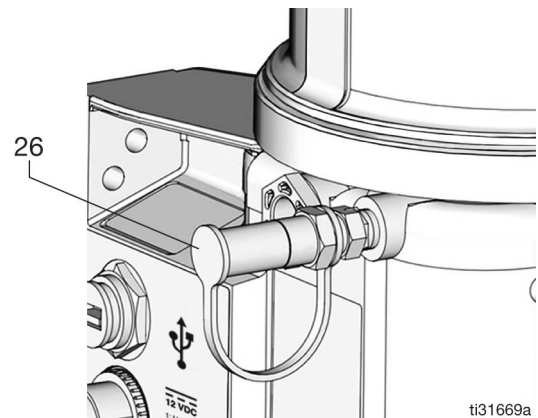

FIG. 29

Prime the Pump

NOTE: It is not necessary to prime the pump every time the pump is filled with lubricant. The pump only requires priming the first time used or if it is allowed to run dry.

1. Loosen the pump outlet fitting (FIG. 30).

NOTE: When loosening the pump outlet fitting, do not loosen the banjo bolt (A).

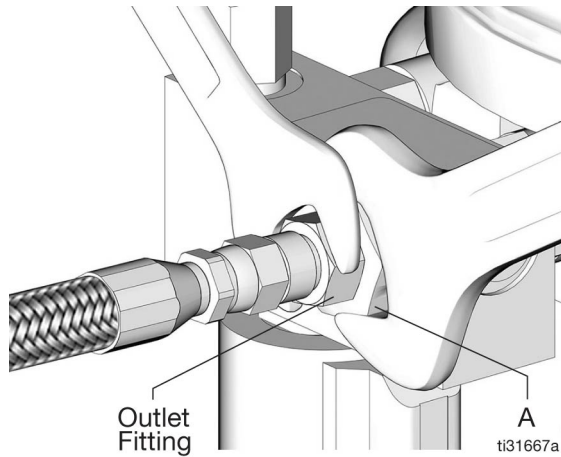

FIG. 30

2. Run the pump only until air-free lubricant dispenses from the element fitting (FIG. 31).

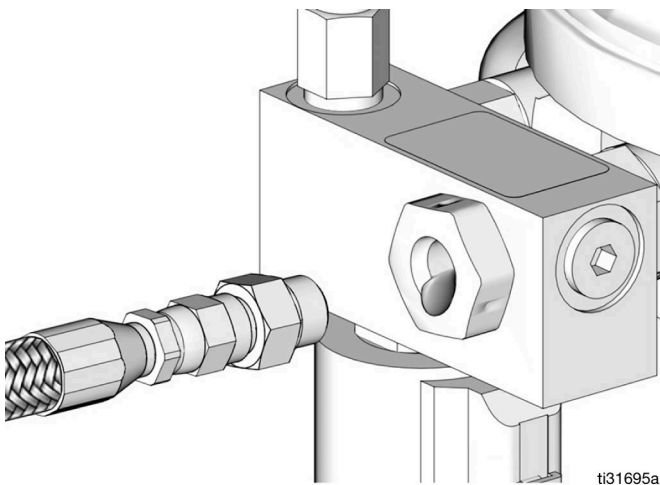

FIG. 31

3. Tighten the pump element fitting using two wrenches working in opposite directions.

Program the Pump

Control Panel Overview (FIG. 32)

NOTE: Program instructions begin on page 26.

OFF TIME

- LED lights when OFF Time is used to control Pump OFF function.
- Value is entered in HH:MM.
- Displays in HH:MM (hours and minutes) when > 1 hour.
- Times pump rest between cycles.
- Counts down from set time to zero.

DISPLAY

- The blinking LED under HH, MM, SS or ## identifies type of measurement unit you are setting; i.e., HH is hours.
- A blinking number on the display indicates the pump is in SETUP MODE.
- In RUN MODE displayed numbers count up or down. See Time ON and Time OFF.

ON TIME

- LED lights when ON Time is running.
- Display shows time as MM:SS (minutes and seconds) i.e., 08:30 is 8 minutes: 30 seconds.
- Counts down from a set time to zero.

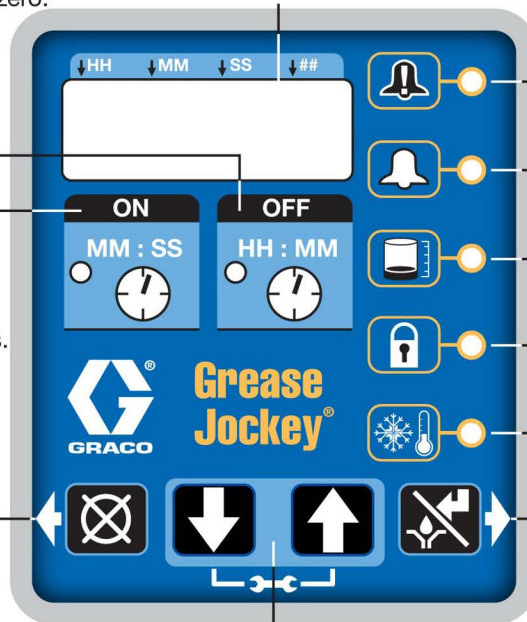

ALARM ICONS

- LED next to icon lights when a fault/warning event occurs during a run cycle. See page 47 for a complete description of these alarm scenarios.

PIN ICON

- LED next to icon lights indicating PIN is required to enter setup.
- In SETUP MODE LED lights when setting up the PIN.

COLD DELAY

- LED next to icon lights indicating when COLD Delay function is enabled.

LEFT DIRECTION ARROW/RESET

- In SETUP MODE: moves cursor in display one field to the left.
- In RUN MODE: single press clears warning.
- In RUN MODE: pressing for 1 second ends run cycle if there are no warnings.
- In ALARM MODE: pressing and holding for 3 seconds clears fault/warning and switches cycle to OFF MODE.

UP and DOWN ARROW

- Hold both the UP and DOWN ARROW buttons down together for 3 seconds to enter SETUP MODE.
- In SETUP MODE: increases or decreases number values shown in display.

RIGHT DIRECTION ARROW/MANUAL RUN/ENTER

- In SETUP MODE: saves entry, moves cursor in display one field to the right or to the next setup step.
- In RUN MODE: starts a manual run cycle.

ti00050a

FIG. 32

Quick Setup Guide - DMS and Illuminated Remote Run Models

Pump System

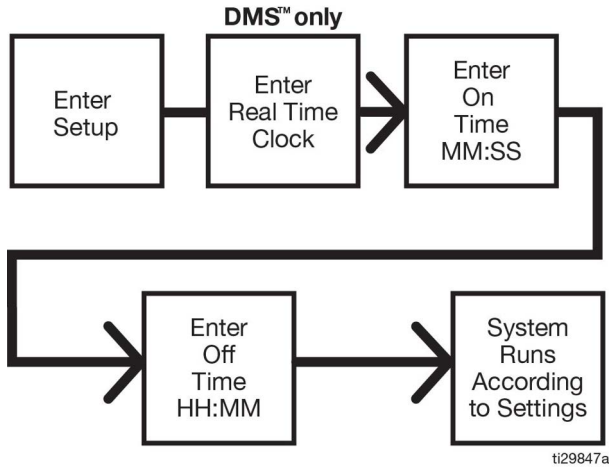

ti29847a

Fig. 33

Check the Firmware Version

To check the firmware version installed on the pump:

1. Disconnect the power cable to the pump from the connection.
2. Reconnect the power cable to the power connection.

This creates a power cycle and the firmware version displays on the screen during the first few seconds of power up (Fig. 34).



ti00051a

Fig. 34

Pump Software

When the pump is powered, d7 or d9 displays for a short period of time. If it does not display, contact Graco Customer Service.

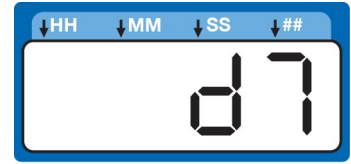

ti00052a

By default, units with controllers are set to operate in a timed mode with 7 minutes of ON time and 2 hours and 53 minutes of OFF time. The unit should be powered up in OFF mode, counting down from the 2 hours and 53 minutes. If the unit powers up in ON mode, and has not been primed, push the reset button located on the control panel (example shown on the right) for 1 second to move to OFF mode.



ti00053a

NOTE:

- A blinking number on the display indicates that the pump is in SETUP MODE.
- The numbers on the display do not blink in RUN MODE.
- After 60 seconds of no activity the device returns to RUN MODE in the OFF Time cycle, and the OFF Time restarts counting down the total programmed amount of time. It does not resume the countdown from the point where the cycle was interrupted when SETUP MODE was entered.

Enter Setup Mode

Press both the UP and DOWN ARROW buttons together for 3 seconds to enter SETUP MODE.

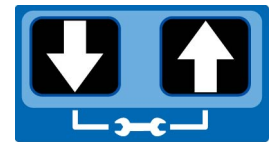

ti00054a

NOTE: If the lock LED is lit after entering SETUP MODE and 4 zeros (0) are displayed, a PIN Code lock out is enabled. See **Enter a PIN Code to Access Setup Mode.**

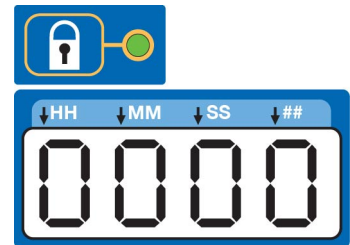

ti00055a

Enter a PIN Code to Access Setup Mode

The controller does not require a PIN code to access the programming features of the unit. However, some users may want to protect the programming settings so an option for adding PIN Code authorization is available.

For instructions on setting up PIN Code Authorization see **Advanced Programming**, page 40.

Enter the PIN Code:

1. Press both the UP and DOWN ARROW buttons for 3 seconds.

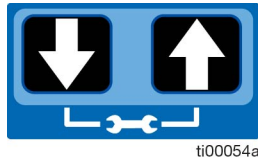

2. The LED next to the LOCK ICON on the display lights and 4 zeros (0) display to indicate that the system requires a PIN Code entry to run SETUP MODE.



3. The cursor automatically positions to enter the first character of the PIN Code. Use the UP and DOWN ARROW buttons to move through the numbers 0-9, until the first number of the PIN code is displayed in the field.

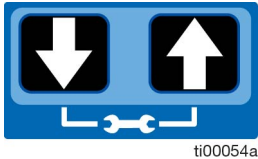

4. Press the ENTER button to set the number. The cursor automatically moves to the next number field.



5. Repeat steps 3 and 4 for each PIN Code prompt field.

When the correct PIN Code is entered, the first editable character on the display flashes.

NOTE: A blinking field on the display indicates that the pump is in SETUP MODE. The numbers on the display do not blink in RUN MODE.

Set the Real Time Clock

DMS and Illuminated Remote Run Button Models

NOTE: Set the real time clock before plugging the USB flash drive into the pump.

Enter the Year

The year displays. The first programmable character, the decade, blinks to indicate that the device is ready to program.



The LED under the # sign lights while setting the year.

1. Use the UP and DOWN ARROW buttons to move through the numbers 0-9, until the number for the current decade is displayed in the field.

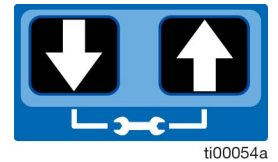

2. Press the ENTER button to set the decade number. The cursor automatically moves to the next field, the year number.



3. Use the UP and DOWN Arrow buttons to move through the numbers 0-9, until the number for the current year is displayed in the field.

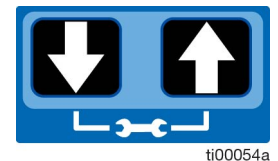

4. Press the ENTER button to set the year number.



The 3-character month displays indicating it is ready to program the month.

Enter the Month



ti00060a

1. Set the 3 character month using the UP and DOWN ARROW buttons to move through the list of months until the current month displays in the field.

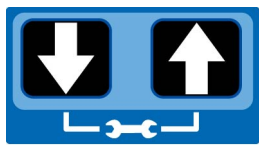

ti00054a

2. Press the ENTER button to set the month.

The 2-digit date displays indicating it is ready to program the date.



ti00057a

Enter the 2-digit Date

The first programmable character of the 2-digit date blinks indicating the device is ready to program the first digit of the date.

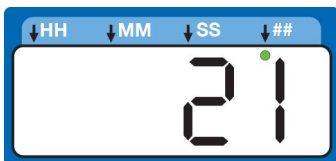

ti00059a

The LED under the # sign lights while setting the date.

1. Use the UP and DOWN ARROW buttons to move through the numbers 0-3 until the first digit of the date is displayed in the field.

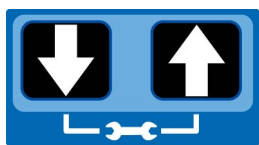

ti00054a

2. Press the ENTER button to accept the selection. The cursor automatically moves to the second digit of the date.



ti00057a

3. Use the UP and DOWN ARROW buttons to move through the numbers 0-9, until the second digit of the date is displayed in the field.

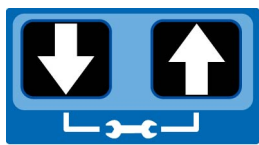

ti00054a

4. Press the ENTER button to set the date.



ti00057a

The time displays indicating the unit is ready to program the time.

Enter the Time

- The time is set in Hours and Minutes (HH:MM).
- The LED under the HH lights when setting hours, and the LED under the MM lights when setting minutes.

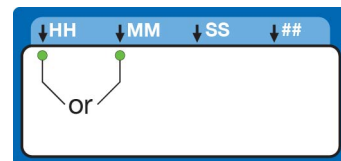

ti00061a

- The time displays in a 24-Hour format. i.e., 2:45 PM displays as 14:45.
- When programming a time of less than 12 hours, program a leading zero in the first number field and press the ENTER button to save the zero.
- The first programmable number of the HH (hour) field blinks, indicating the device is ready to program the first digit of the hour.

1. Use the UP and DOWN ARROW buttons to move through the numbers 0-2, until the desired number appears in the first hour (HH) field.



ti00054a

2. Press the ENTER button to set the number.



ti00057a

3. Use the UP and DOWN ARROW buttons to move through the numbers 0-9, until the desired number appears in the second HH number field.

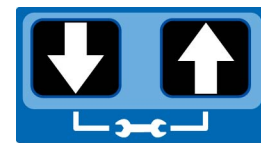

ti00054a

4. Press the ENTER button to set the number.



ti00057a

5. The next number field to the right blinks and the LED under the MM lights, indicating the device is ready to program the minutes fields.

6. Repeat steps 1-4 to set the minutes (MM) fields.

7. After pressing the ENTER button to set the time, the programmed information is saved.



ti00057a

Pressure Control (P1, P2, P3) Setup (Models 25V619 and 2008338 Only)

- For injector systems, monitoring pressure can be used to ensure sufficient pressure has been reached to activate the injectors. The pump runs, building up enough pressure to cause the injectors to dispense fluid. Pressure continues to build to a preset maximum, activating the user supplied pressure switch. Then an external user supplied vent valve opens and pressure reduces, priming the injector for the next cycle.
- Pressure control is an ON / OFF selection only.

- Use the UP and DOWN ARROW buttons to toggle between OFF/C1/P1.

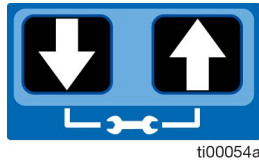

- When P1 displays, press the ENTER button to save the selection.

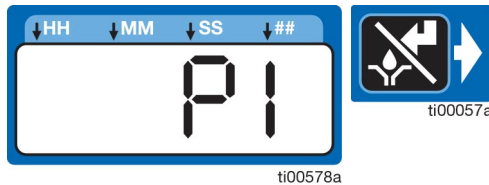

Input Not Used

Select OFF if the system does not use the applicable input.

- Use UP and DOWN ARROW buttons to toggle between OFF/C1/P1 on the display.

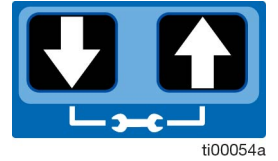

- When OFF displays, press the ENTER button to save the selection.

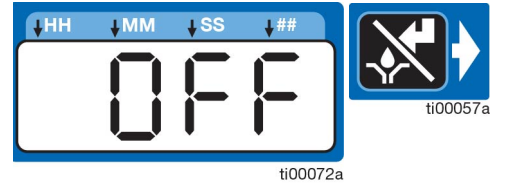

If the sensor inputs are available and none are used in ON Mode, the definition of the entered time is ON TIME.

Backup Time

In Pressure Mode, a maximum run time (Backup Time) for the lubrication period must be set. If this time expires before the lubrication is completed, an alarm/warning is triggered and the pump stops.

To determine Backup Time, verify the length of time it to complete a typical cycle, and double that value (to a maximum of 30 minutes).

Backup Time is setup after Pressure Sensor Setup is complete.

ON Time or Backup Time

- The LED next to the clock in the ON field lights to indicate the ON Time parameters are being set.

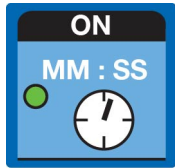

ti00062a

- ON Time is set in Minutes and Seconds (MM: SS).

- An LED flashes under the MM when programming minutes, or under the SS when programming seconds.

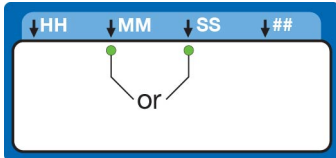

ti00544a

- In SETUP MODE the number displayed in the first field, the left side of the display blinks to indicate that the device is ready to program the ON Time minutes.

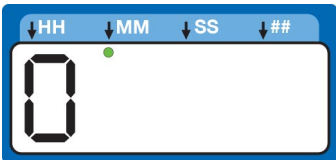

ti00064a

- The ON Time total amount cannot be 0 or exceed 30 minutes. If a value of 0, or a value greater than 30 minutes is entered, the RED alarm LED lights and the value must be updated.



ti00065a

Program ON Time

NOTE: When a time of less than 10 minutes is being programmed, enter a leading zero (0) in the first number field and press the ENTER button to save the zero selection.

- To set ON Time, use the UP and DOWN ARROW buttons to move through the numerals 0 to 9, until the desired number appears in the first MM (minutes) field.

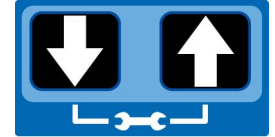

ti00054a

- Press the ENTER button to lock in the selection. The next MM number field to the right flashes to indicate that it is ready to be programmed.



ti00057a

- Use the UP and DOWN ARROW buttons to move through numerals 0 to 9, until the desired number appears in the second MM number field.



ti00054a

- Press the ENTER button to lock in the selection.



ti00057a

The next number field to the right flashes and the LED lights under SS; this indicates it is ready to program the seconds fields.

- Repeat steps 1 - 4 to set the SS (seconds) fields.

- After pressing the ENTER button to set the last SS field, all of the programmed ON Time information is saved.



ti00057a

It automatically switches to the OFF Time SETUP MODE.

PUMP OFF / REST Setup

After setting the parameter for ON time, the OFF or pump rest cycle must be set for a specific amount of time (similar to Time Mode).

OFF Time

- The LED next to the clock in the OFF field lights to indicate the OFF Time parameters are being set.

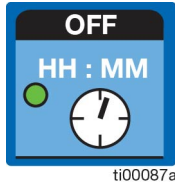

- OFF Time is set in Hours and Minutes (HH: MM).

- An LED flashes under the HH when programming hours, or under the MM when programming minutes.

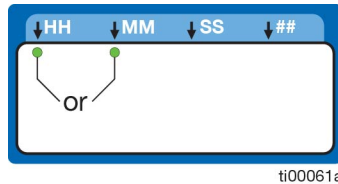

- In SETUP MODE the number displayed in the first field, the left side of display blinks to indicate that the device is ready to program the OFF Time hours.

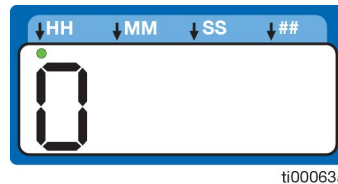

- The OFF Time total amount must be at least twice as long as the programmed ON Time. If a value less than twice the ON Time is entered, the RED alarm LED lights and the value must be updated. If this time does not meet the application needs, contact Graco Customer Support.



Program OFF Time

NOTE: When a time of less than 10 hours is being programmed, enter a leading zero(0) in the first number field and press the ENTER button to save the zero selection.

- To set OFF Time use the UP and DOWN ARROW buttons to move through numerals 0 to 9, until the desired number appears in the first HH (hour) field.

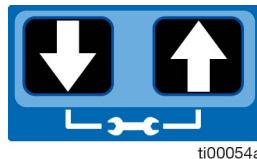

- Press the ENTER button to lock in the selection. The next HH number field to the right flashes to indicate it is ready for programming.



- Use the UP and DOWN ARROW buttons to move through numerals 0 to 9, until the desired number appears in the second HH number field.

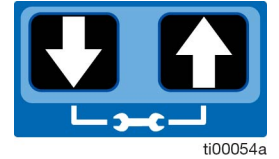

- Press the ENTER button to lock in the selection.



The next number field to the right flashes and the LED lights under MM; to indicate it is ready to program the minutes fields.

- Repeat steps 1 - 4 to set the next MM (minutes) fields.

- After pressing the ENTER button to set the last MM field, the OFF Time information is saved and the pump automatically switches to RUN MODE.



Recommended Timer Setting	
Timer Setting	Driving Conditions
1/2 or 1 hr	Off Highway
1 1/2 or 2 hr	Start and stop city, heavy salt, snow and ice, rough pavement, wet climate, heavy loads, dusty roads.
3 hr	Normal city or highway driving, normal climate, moderate loads.

DMS™ Models

Download Data

- Remove the USB cover from the USB port (D).
- Plug a USB flash drive into the USB port (D).

NOTE: The pump stops as soon as the USB flash drive is plugged into it.

- The system automatically begins downloading data to the USB drive.

Pump

- The display reads data while the system downloads the files.



- When the download is finished, the display reads done.

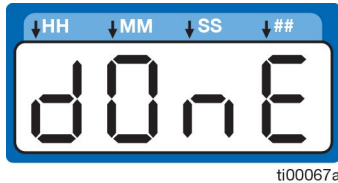

- The pump restarts the cycle in OFF mode.

- Remove the USB flash drive. Replace the USB cover and hand tighten the cover securely over the USB port (D).

Store Pump Program Settings to the Flash Drive

The pump program settings file is named:

GRACO/Config/config.bin. This file cannot be modified. Modification of the file or file name may cause it to be unusable.

- Plug the USB flash drive into the USB port (D).

NOTE: The pump stops as soon as the USB flash drive is plugged into it.

- The system automatically begins downloading data to the USB drive.

- The display reads data while the system downloads the files.



- When the download is finished, the display reads done.

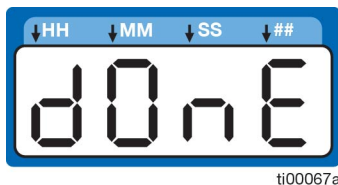

- The pump restarts the cycle in OFF mode.

- After the download is complete, press and hold the UP and DOWN ARROW buttons for 3 seconds to store the current setup to the USB flash drive.

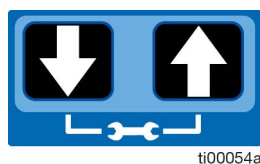

- The display reads data while the unit is downloading and storing the configuration on the USB drive.



- When the configuration is stored, the display reads done.

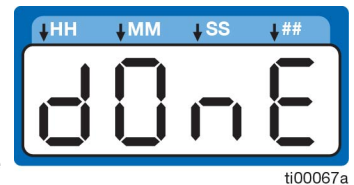

- The pump restarts the cycle in OFF mode.

- Remove the USB flash drive.

Upload Pump Program Settings to the Pump

- Plug the USB flash drive into the USB port (D).

NOTE:

The USB flash drive must contain file GRACO/Config/config.bin.

The pump stops as soon as the USB flash drive is plugged into it.

- The system automatically begins downloading data to the USB drive.

- The display reads data while the system downloads the files.



- When the download is finished, the display reads done.

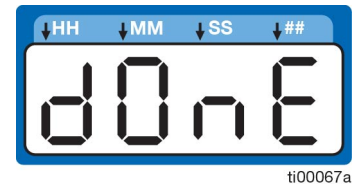

- The pump restarts the cycle in OFF mode.

- After the download is complete, press and hold the RESET button and the UP ARROW button for 3 seconds to upload the setup stored in the USB flash drive.

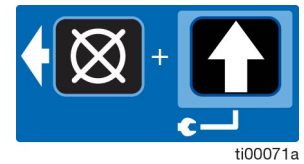

- The display reads data while the unit uploads the configuration data.



- When the upload is finished, the display reads done.

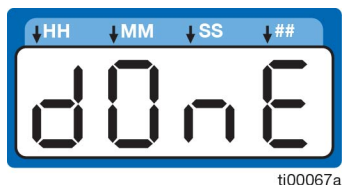

- The pump resumes operation.

- Remove the USB flash drive.

- After the USB flash drive is removed, press and hold the UP and DOWN ARROW buttons for 3 seconds to enter SETUP MODE (see **Enter Setup Mode**, page 26).

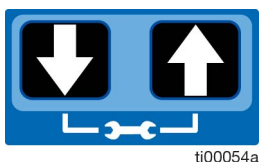

- In SETUP MODE, set the YEAR, MONTH, DATE and TIME (see **Set the Real Time Clock**, page 27).

- After pressing the ENTER button to set the TIME, press the RESET button to exit SETUP MODE.



View the UNIT DMS ID Number

- In RUN mode, press and hold the DOWN ARROW button.
- The Unit DMS ID number displays. The unit continues to normal operation while the DMS ID is displayed.



- Release the DOWN ARROW button after viewing the DMS ID number.

Operation / Data Log

During operation the pump stores information as Log and Summary Files.

Logs contain the following information:

- Log Name
- DMS ID Number
- Current Software Graco Part No.
- Current Software Version
- Date and Time of Upload

System Event Log

The System Event Log lists the date and time of the last 800 common system events, such as pump cycles, manual run, and setting changes with the most recent event listed first.

The log file is stored in a folder structure created by the pump DMS ID and download date. If multiple downloads are done on the same date, the existing files are written over.

The folder structure is as follows:

GRACO/{DMS_id}/{download date - YYYYmmDD}/EVENTLOG.CSV

Example: GRACO/00613/20160911/EVENTLOG.CSV.

Sample System Event Log

Example Event Log: The pump cycle of a typical lubrication system is shown below.

System Event Log

DMS ID Number: 00613

Software Part No.: 17J936

Software Version: 0703

09/29/2016 14:1400

Date	Time	Description
9/29/2016	14:13:02	Pump Run Off
9/29/2016	14:13:02	Program Variable Change
9/29/2016	14:12:39	Pump Run On
9/29/2016	14:12:34	Local Manual Run Initiated

Common System Events are listed below.

Pump Run On	The pump entered an on cycle and is operating and dispensing material.
Pump Run Off	The pump entered an off cycle and is not dispensing.
Pump Run Canceled	A pump on cycle was canceled by pressing the cancel button on the front panel and holding it for 3 seconds.
Program Variable Change	The setup mode was entered.
Local Manual Run Initiated	The manual run button was pressed, initiating a pump on cycle.
Remote Manual Run Initiated	The remote manual run button was pressed initiating a pump on cycle.
Successful Pin Code Entry	The pin code was successfully entered and the user has entered setup mode.
Cold Delay	The pump entered a cold delay
Firmware Update Completed	The firmware was updated successfully.

Error Log

The Error Log lists Set Time and Clear Time for the last 400 faults and warnings. The most recent event is listed first.

The log file is stored as:

GRACO/{DMS_id}/{download date - YYYYmmDD}/ERRORLOG.CSV

Example: GRACO/00613/20160911/ERRORLOG.CSV.

Sample Error Log

Error Log
 DMS ID Number: 00613
 Software Part No.:17J936
 Software Version:0703
 12/31/2016 23:04:00

Date	Time	Description
12/31/2015	23:03:54	Low Level Cleared
12/31/2015	23:03:42	Low Level Fault
12/31/2015	23:03:32	Low Level Warning
12/31/2015	23:03:22	Over Current
12/31/2015	23:03:19	Over Current Shut Down

Common Error Log entries are listed below.

Software Fault	An internal software error occurred. Contact Graco Customer Service.
Low Level Warning	The unit entered a low level warning mode and is running low on material. The pump continues to dispense material for the duration of the low level alarm time specified by the unit.
Low Level Fault	The alarm time in low level warning has elapsed. The unit will not pump until the reservoir is filled and the fault is cleared.
Motor Over-current Warning	The unit is out of expected motor current range. Check the system to determine that it is functioning correctly (i.e., no blocked lines). Continued operation at excessive motor currents will cause degradation in pump life.

High Temperature Warning	Internal temperature of the unit is above the designated operating temperature. Check the unit and system to determine that it is functioning correctly. Operating outside of the specified temperature range may cause reduced performance and possible unit failure.
Motor Over-current Fault	The unit is out of expected motor current range. Check the system to determine that it is functioning correctly (i.e., no blocked lines). Continued operation at excessive motor currents will cause degradation in pump life.
Low Temperature Warning	Internal temperature of the unit is below the designated operating temperature. Check the unit and system to determine that it is functioning correctly. Operating outside of the specified temperature may cause reduced performance and possible unit failure.
Low Power Fault Pump On	The power source does not have enough power to power the pump when it turns on. Replace power source.
Low Power Warning Cleared	The voltage of the power source dropped below and acceptable threshold. The warning was cleared either by user intervention, or by self-correction.
Low Power Fault Cleared	The voltage of the power source dropped below an acceptable threshold for longer than 15 minutes and the pump faulted out. The fault was cleared by the user.
USB Unable to Mount	The USB flash drive that was installed was unable to connect and communicate with the pump.
USB Unsupported Device	The USB flash drive is unsupported. Use a different flash drive.

Pump

USB File Not Found	The pump program setting file was not found or created correctly. Restore the setting file to the flash drive.
USB Folder Navigation	The pump program setting file was not found or created correctly. Restore the setting file to the flash drive.
USB Invalid File	The pump program settings file was not found or created correctly. Restore the setting file to the flash drive.
Failed Pin Code Entry	A failed attempt was made to enter the pin code password.

Functional Summary

The Functional Summary contains two types of data.

- The first report type, labeled User (under the Type heading in the first column of the Sample Functional Summary), only provides data compiled since the last time the Functional Summary was reset through present day (see A6 - Clearing the Functional and Technical User Summary, page 42).

This is very similar to the resettable car trip odometer.

- The second report type, labeled Factory (under the Type heading in the first column of the Sample Functional Summary), covers the cumulative life of the pump from the first day it was put into service through present day.

This is very similar to a car odometer.

The log file is stored as:

GRACO/pump_{DMS_id}/{download date - YYYYmmDD}/FUNCSUM.CSV

Example:

GRACO/pump_00025/20100911/FUNCSUM.CSV

Sample Functional Summary

Functional Summary														
DMS ID Number:00613 (Hold Down Arrow On Pump to View)														
Software Part No.:17J936														
Software Version:0703														
9/13/2016 11:15:35														
Type	Start Date	Lube Cycles	Pump Run	Powered On	Local Manual Run	Remote Manual Run	Average Run Time	Average Duty Cycle	Max Duty Cycle	Low Level Faults	Other Faults	Fault Hours	Low Level Warning	Other Warnings
User	9/13/2016	29	0 hrs	119 hrs	25	2	0:01:30	0.62%	0.62%	4	1	112 hrs	11	0
Factory	9/13/2016	29	0 hrs	119 hrs	25	2	0:01:30	0.62%	0.62%	4	1	112 hrs	11	0

Common Functional Summary Data entries are listed below.

Number of Cycles	The number of lubrication cycles the unit has started.
Total Run Hours	Total amount of hours the pump has been in the ON mode of the ON/OFF cycle.
Total Powered On Hours	Total number of hours that the unit has been powered on.
Local Manual Run	The number of times the manual run button was pressed.
Remote Manual Run	The number of times the remote manual run button was pressed.
Average Run Time	The average amount of time per lubrication cycle that the pump has been running (MM:SS).
Average Duty Cycle	The average percentage of time the unit has been pumping while it has been powered on.
Max Duty Cycle	The highest percentage of time for one lubrication cycle that the unit has been pumping while it has been powered on.
Total Low Level Faults	Total number of low level faults.
Total Other Faults	Faults other than low level or sensor feedback.
Total Fault Hours	Number of hours the system has been powered on in fault mode.
Total Low Level Warnings	Number of low level warning conditions.
Total Other Warnings	All other warnings, including temperature and motor current.

Technical Summary

The Technical Summary contains two types of data.

- The first report only provides data compiled since the Pump Summary was reset to present day (see A6 - Clearing the Functional and Technical User Summary).

This is very similar to the resettable trip odometer in your car.

- The second is a report that covers the cumulative life of the pump from the first day it was put into service to present day.

This is very similar to an odometer in your car.

The log file is stored as:

GRACO/{DMS_id}/{download date - YYYYmmDD}/TECHSUM.CSV

Example: GRACO/00025/20100911/TECHSUM.CSV

Common Technical Summary Data entries are listed below.

Average Input Board Voltage (DC)	The average input voltage measured by the internal circuit board.
Peak Input Board Voltage (DC)	The peak input voltage measured by the internal circuit board.
Average Motor Current	The average motor current measured by the unit.
Peak Motor Current	The peak motor current measured by the unit.
Average Internal Temperature	The average internal temperature seen by the unit.
Peak Internal Temperature	The peak internal temperature seen by the unit.
Low Internal Temperature	The lowest internal temperature seen by the unit.

Sample Technical Summary

Functional Summary								
DMS ID Number:00613 (Hold Down Arrow On Pump to View)								
Software Part No.: 17J936								
Software Version:0703								
9/13/2016 11:15:35								
Latest Values								
Temp	Voltage							
25C	11.846							
Type	Start Date	Average Board Voltage	Peak Board Voltage	Average Motor Current	Peak Motor Current	Average Internal Temp	Peak Internal Temp	Low Internal Temp
User	9/13/2016	11.842	11.908	2.426	2.945	29C	31C	21C
Factory	9/13/2016	11.842	11.908	2.426	2.945	29C	31C	21C

Advanced Programming

Identifies each option and when used.

Advanced Option	Model	Setting	Format/ Description	Why Use This?
A1	All Models	Lockout Code (Optional)	Secures setup modes with PIN	Prevents unauthorized users to adjusting settings.
A4	Telematic	Alarm Retry	Sets the number of automatic retries after a Cycle or Pressure Alarm. The Default is zero (0).	Establishes the number of time that the unit automatically retries lubrication after a cycle or pressure alarm to determine if a temporary or false signal can be cleared.
A5	Telematic	Active Alarm	Changes the alarm output behavior. The Default is zero (0).	<p>Uses alarm output to determine if a unit has an alarm and/or loses power.</p> <p>The output turns on when power is applied. It turns off when power is lost or when an alarm occurs.</p> <p>Normal operation (off) will only activate an alarm output during an alarm condition while the power is on.</p> <p>Can change (set to on) to activate alarm with power on and deactivate with power off or warning.</p> <p>Used to manage power outage.</p>
A6	DMS Equipped Models	Functional and Technical User Summary Reset	Clears the Functional and Technical User Summaries	Allows user to track lube events from a specific point (reset), i.e. a month to month evaluation.
A7	Telematic	Constant Alarm Output on Fault	Changes the alarm output behavior. The Default is off.	Changes the behavior of the low level output in a warning or fault from either toggling once per second or steadily on.
A9	Telematic	Toggle low level output on warning or fault	Changes the low level indication behavior. The Default is off.	Changes the behavior of the low level output in a warning or fault from either steadily on or toggling once per second,
A10	All	Low Level Reset Upon Power On	Clears low level fault upon power on. The Default is off.t.	Changes the behavior of the low level fault when powered.
A11	Telmatic	Warning off through alarm relay	Changes the alarm output behavior. The Default is off.	Changes the behavior of the alarm output in a warning condition to off.

Enter a PIN Code for the First Time

A1 - Set Up PIN Code

A PIN Code can be programmed into the pump to protect the settings from inadvertently being changed by unauthorized users.

1. Press the UP ARROW button for 10 seconds.



The LED next to the LOCK ICON on the display lights, indicating it is in PIN Mode.



2. The word OFF appears on the display. Press the UP and DOWN ARROW buttons to change to ON.

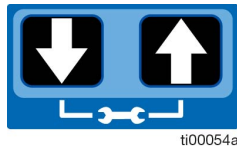

3. Press the ENTER button to enter the PIN Code.



4. The cursor automatically positions to enter the first character of the PIN Code. Use the UP and DOWN ARROW buttons to move through the numbers 0-9, until the first number in the PIN code is displayed in the field.

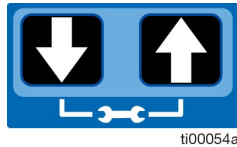

5. Press the ENTER button to set the number. The cursor automatically moves to the next number field.



6. Repeat steps 4 and 5 for each PIN Code prompt field.

7. Press the ENTER button to save the PIN Code and exit Advanced Setup.



Enter Advanced Setup

Press the UP ARROW button for 10 seconds.

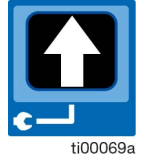

If the pump was previously set to require a PIN Code, the LED next to the LOCK ICON lights, indicating a PIN Code is required.

1. The cursor automatically positions to enter the first character of the PIN Code. Use the UP and DOWN ARROW buttons to move through the numbers 0-9, until the first number in the PIN code is displayed in the field.

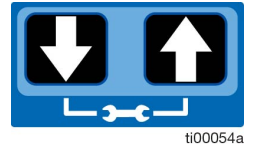





2. Press the ENTER button to set the number. The cursor automatically moves to the next number field.

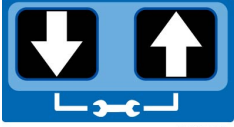

3. Repeat steps 1 and 2 for each PIN Code prompt field.

If the PIN Code entered is correct, the first editable character on the display flashes.



Select Advanced Setup Options

1. Press the UP and DOWN ARROW buttons to move between Advanced Options.  ti00054a
2. Press the ENTER button to set the selection.  ti00057a
3. When the correct number displays, press the ENTER button to set the number.  ti00057a
4. Repeat 2 - 3 to set the remaining fields.
5. Press the ENTER button to exit Advanced Programming.  ti00057a

A4 - Alarm Retry

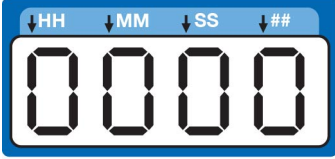
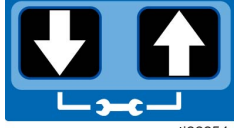

Programs the number of times the Electric Grease Jockey automatically retries running a lubrication cycle after a cycle or pressure alarm activates. The default setting is 0. For assistance in determining a reasonable number of Alarm Retries to program for the application, contact Graco Customer Service or your local Graco distributor.

To set the Alarm Retry:

1. The default value 0000 appears in the display.  ti00055a
2. Press the UP and DOWN ARROW buttons to move through numbers 0-9.  ti00054a
3. When the correct number displays, press the ENTER button to set the number.  ti00057a
4. Repeat 2 - 3 to set the remaining fields.
5. Press the ENTER button to exit Advanced Programming.  ti00057a



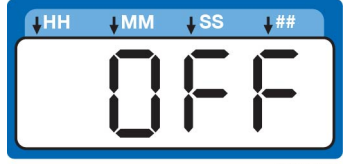
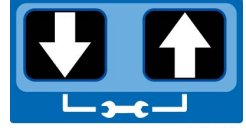



A5 - Active Alarm

Changes the alarm output behavior. Output is used to determine if a fault has occurred.

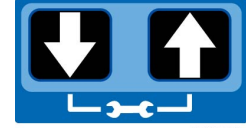
1. The default OFF displays.  ti00072a
2. Press the UP and DOWN ARROW buttons to change OFF to ON on the display to activate the alarm condition.  ti00054a
3. Press the ENTER button to exit Advanced Programming.  ti00057a

A6 - Clear the Functional and Technical User Summary (DMS™ Models only)

The Pump Summary shows run details since the last time the summary was cleared.

1. Press the UP and DOWN ARROW buttons to move through Advanced Options until Advanced Option A6 displays.  ti00054a
2. Press the ENTER button.  ti00057a
3. The display reads data.  ti00057a
4. Press the RESET button. Reset display, and the summary data is cleared.  ti00053a  ti00070a
5. Press the RESET or ENTER button to exit.  ti00053a  ti00057a

A7- Constant Alarm Output ON Fault

This changes the behavior of the alarm output in a fault from either toggling once per second (default) or steady on.

1. The default OFF displays. The alarm output toggles once per second.

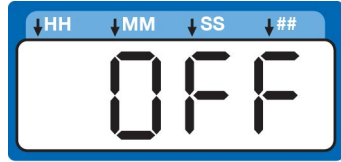

ti00072a

2. Press the UP and DOWN ARROW buttons to change OFF to ON on the display, and to change the alarm output to steady on.

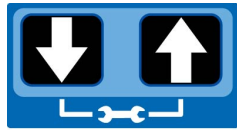

ti00054a

3. Press the ENTER button to exit Advanced Programming.



ti00057a

A9 - Toggle Low Level Output on Low Level Warning or Fault

This changes the behavior of the low level output in a warning or fault from either steady on (default) or toggling once per second.

1. The default OFF displays. The alarm output toggles once per second.

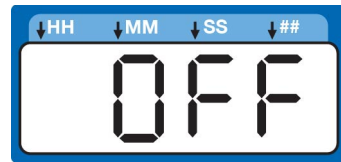

ti00072a

2. Press the UP and DOWN ARROW buttons to change OFF to ON on the display, and to change the alarm output to steady on.



ti00054a

3. Press the ENTER button to exit Advanced Programming.



ti00057a

A10 - Low Level Reset Upon Power On. (Models with Firmware 5.04 and later. DMS Models with Firmware 7.07 and later.)

This changes the behavior of the low level upon pump power on. When A10 is on, a low level fault clears when the pump power is cycled. The pump revolves 5 revolutions, checking to see if the low level condition is still present. If not, it self clears and continues. If a low level condition exists during the 5 revolutions, it goes into a low level fault.

Low Level ON LED illuminates (FIG. 35).

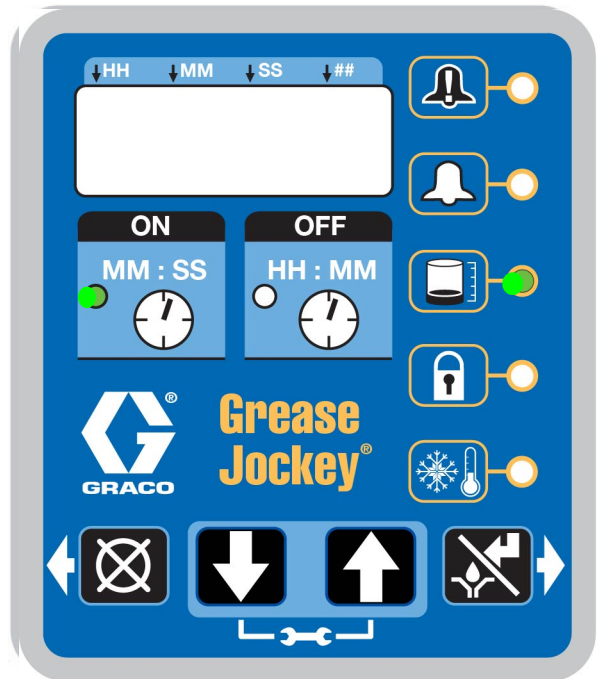

ti00088a

FIG. 35

1. The default OFF displays. The alarm output toggles once per second.

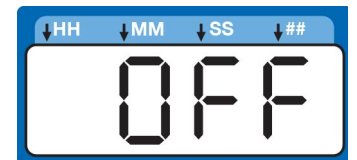

ti00072a

2. Press the UP and DOWN ARROW button to move through Advanced Options until Advanced Option A10 displays.

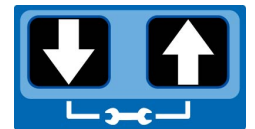

ti00054a

3. Press the ENTER button.



ti0005

A11- Warning Off Through Alarm Relay

This changes the behavior of the alarm output in a warning condition to always off.

1. The default OFF displays. The alarm output turns on during a warning condition.

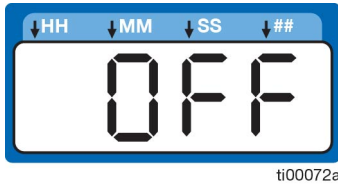

2. Press the UP and DOWN ARROW buttons to change OFF to ON on the display, and to change the alarm output to off during a warning condition.

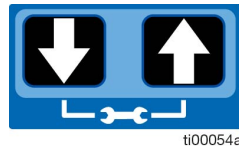

3. Press the ENTER button to exit Advanced Programming.



Time Control

After setup is complete, the pump automatically begins to run the OFF Time sequence (FIG. 36).

- The pump runs the programmed OFF sequence.

(Notice the OFF Time LED on the display lights and the OFF Time counts down on the display.)

- The example shown in FIG. 36 shows an OFF Time of 1 hour and 32 minutes before the lubrication cycle begins.



FIG. 36

- When the OFF Time count reaches zero (0), the pump turns on and runs for the programmed ON Time cycle (FIG. 37).

(Notice the ON Time LED is now illuminated on the display.)

- The example shown in FIG. 37 shows an ON Time of 6 minutes before the lubrication cycle ends.



FIG. 37

- When the ON Time count reaches zero(0), the pump shuts off and the system again runs the OFF Time cycle, and the OFF Time LED is now illuminated (FIG. 36).

This sequence repeats until the device is reprogrammed, or an alarm occurs.

- For firmware versions Basic 4.02 or earlier, or DMS 0709 or earlier, if power to the pump is lost during a lubrication cycle, when power is restored the pump resumes the cycle with the same amount of time remaining in the cycle when power was lost.
- For Firmware version Basic 4.03 or later, or DMS 0710 or later, if power to the pump is lost:

In the OFF state, it resumes the cycle with the same amount of time remaining in the cycle when power was lost.

In the ON or lubricating state, the ON time restarts.

Lubrication Mode (Pump On) Controls

For Telematic option models, the Lubrication Mode (Pump On) can be controlled by a pressure switch.

When the pressure control is set to anything but off, the display alternates between the active sensor (P1) and Backup Time.

When pressure control is set to off, the Lubrication Mode (Pump On) is controlled by On Time (see **Time Control**, page 44).

When pressure control is set, the lubrication cycle (Pump On) ends by meeting the pressure setting.

Pressure Control

- A single triggered count in a pressure based system (P1). It is typically a pressure switch on the end of a line of injectors.
- The display indicates that the sensor (P1), and the pressure switch for that sensor, are triggered.
 - 01 indicates the pressure switch has not been triggered
 - 00 indicates the pressure switch has been triggered

Backup Time

- While in Pressure mode, a Backup Time (maximum run time) needs to be set.
- If pressure requirements are met, the unit exits the lubrication cycle (Pump On), and enters the rest cycle (Pump Off).

Cold Delay

In DMS models, when the pump powers on when the temperature is below 14°F (-10°C), there is a 15 minute cold delay before the pump resumes running the program.

- When power to the unit cycles OFF then ON.
- Temperature is below 14°F (-10°C).
- Unit immediately begins the Cold Delay count down, and then the pump resumes.
- The LED next to the clock in the OFF field is illuminated (FIG. 38).
- The Cold Delay LED lights (FIG. 38).
- The display shows time remaining until the pump resumes. The example shown in FIG. 38 shows 8 minutes and 14 seconds left until the pump resumes.

Manual Run Cycle

To run an extra (non-programmed) lubrication cycle, push the Manual Start button.



FIG. 38

Alarms

Any time a Fault or Warning occurs, a combination of LEDs illuminate to notify that there is a problem and to help identify the kind of Fault or Warning that has occurred.

- Faults do not automatically clear. Warnings clear after a set time, if the condition is fixed.
- To clear a fault, press and hold the RESET button on the display button pad for 3 seconds.
- To clear a warning, instantly press and immediately release the RESET button.



ti00053a









ti00053a

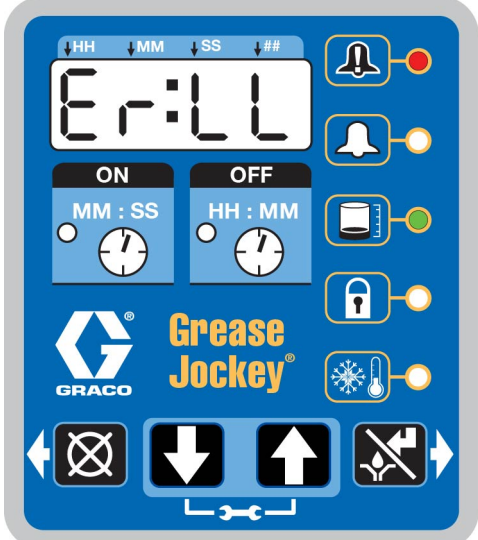

Fault and Warning Scenarios



The following pages describe the most likely faults or warnings that can be received.

Alarm Type	What it Looks Like	What it Indicates	Solution
<p>Low Level Warning</p>	<p style="text-align: right; font-size: small;">ti00076a</p>	<p>Level of lubricant in reservoir is low and additional lubricant needs to be added.</p> <p>Unit continues to operate as normal for a limited period of time until a low level alarm is triggered.</p>	<p>Add lubricant to reservoir.</p> <p>After lubricant is added, press the RESET button to clear the warning.</p> <p style="text-align: right; font-size: small;">ti00053a</p>

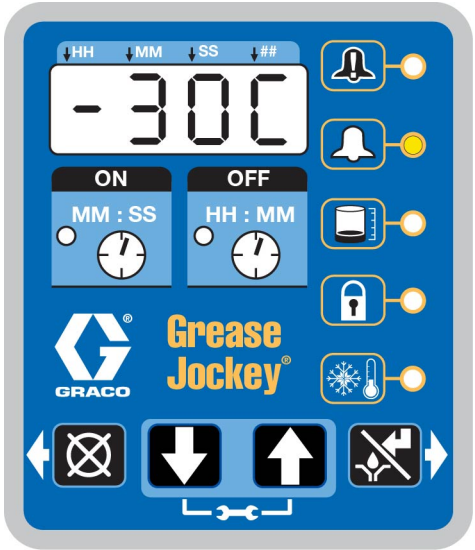

<p>Cycle / Pressure Warning</p>	 <p>ti00077a</p>	<p>System fails to relieve pressure or a lubrication cycle was not completed in the user-defined amount of time.</p> <p>Unit will continue to operate for the number of lubrication cycles set by the warning retry parameter (see Advanced Programming, page 44).</p> <p>If the warning condition clears itself on the next automatic lubrication cycle, the warning is cleared and the unit continues normal operation.</p>	<p>Examine system to determine if you have a plugged or broken line or other component failure, i.e., divider valve, injector.</p> <p>Press the RESET button to clear warning.</p>  <p>ti00053a</p>
<p>Low Level Fault</p>	 <p>ti00077a</p>	<p>Level of lubricant in reservoir is low and additional lubricant needs to be added.</p> <p>Unit stops pumping and displays amount of accumulated time since the alarm was triggered.</p>	<p>Add lubricant to reservoir.</p> <p>After lubricant is added, press the RESET button to clear the warning.</p>  <p>ti00053a</p>

<p>System Fault</p>	 <p>ti00078a</p>	<p>An internal fault has occurred.</p>	<p>Contact Graco Customer Service.</p>
<p>Cycle / Pressure Fault</p>	 <p>ti00580a</p>	<p>In pressure mode indicates that unit is over pressurized or a lubrication cycle was not completed in the user-defined amount of time.</p>	<p>Examine system to determine if you have a plugged or broken line or other component failure, i.e., divider valve, injector.</p> <p>Press and hold the RESET button to clear fault.</p>  <p>ti00053a</p>

<p>Motor Current Warning</p>	 <p style="text-align: right; font-size: small;">ti00079a</p>	<p>The measured motor current is above the recommended operating maximum value. Continued use at excessive motor currents could reduce life or cause permanent damage.</p> <p>Pump tries running cycle 90 times before shutting down. See Pump Over-current Protection, page 18.</p>	<p>Examine system to make sure it is operating correctly. A blocked line could create excessive motor current</p> <p>Examine pump to ensure that it is rotating properly.</p> <p>If necessary, contact Graco Customer Service.</p>
<p>Motor Current Fault</p>	 <p style="text-align: right; font-size: small;">ti00080a</p>	<p>The measured motor current was above the recommended operating maximum value 90 times. Continued use at excessive motor currents could reduce life or cause permanent damage.</p>	<p>Examine system to make sure it is operating correctly. A blocked line could create excessive motor current</p> <p>Examine pump to ensure that it is rotating properly.</p> <p>If necessary, contact Graco Customer Service.</p>

<p>Temperature Warning</p>	 <p style="text-align: right; font-size: small;">ti00081a</p>	<p>The internal temperature of the unit is out of its recommended operating range.</p> <p>Use of the unit outside of the recommended temperature range could cause degraded system performance and possible damage.</p>	<p>Ensure the unit is used in the correct operating environment for the specific temperature: -13° F to 158° F (-25° C to 70°C).</p> <p>If necessary contact Graco Customer Service.</p>
<p>USB Error</p>	 <p style="text-align: right; font-size: small;">ti00082a</p>	<p>An error occurred during a DMS operation.</p>	<p>Read the Troubleshooting section of this manual (page 73) for error numbers and fault descriptions.</p>

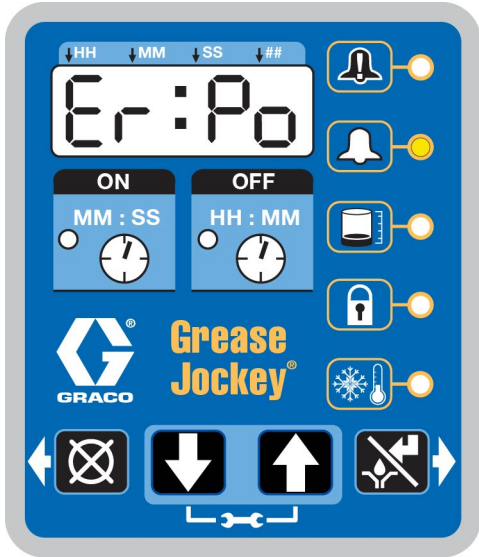
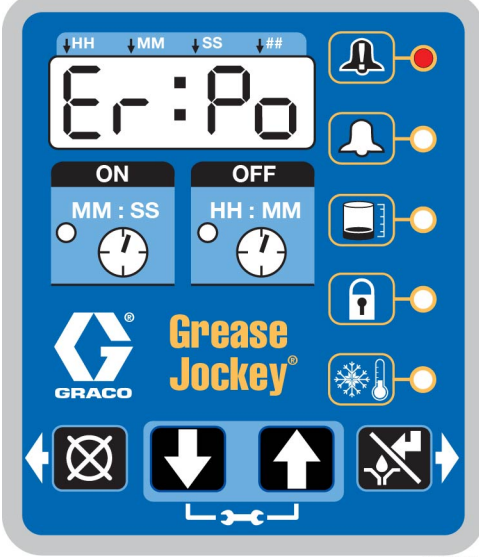
Additional Fault/Warning Scenarios for Firmware Versions 5.06 and Later for Non-DMS Models and 7.09 and later for DMS Models

Alarm Type	What it Looks Like	What it Indicates	Solution
<p>Low Power Warning</p>	 <p>ti00083a</p>	<p>If there is a voltage drop at the power source during operation, the pump will go into a low power warning condition.</p> <p>The unit will continue to operate for a total of 15 minutes before going into a Low Power Fault.</p> <p>Also if the pump power cycles on power up for a minimum of 3 times, the pump will display a low power warning.</p> <p>If the warning condition clears itself, the warning is cleared and the unit continues operation.</p>	<p>Check voltage and available current output at the power source of the pump.</p>
<p>Low Power Fault</p>	 <p>ti00084a</p>	<p>There is a low voltage condition at the power source.</p>	<p>Check voltage and available current output at the power source of the pump.</p> <p>Press and hold the RESET button to clear fault.</p>  <p>ti00053a</p>

Testing Installation

NOTE: Complete instructions for programming the Electric Grease Jockey pump begin on page 72.

1. Power up the pump and enter Setup Mode by pressing both the UP and DOWN ARROW buttons together for 3 seconds.

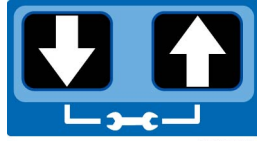

2. Button flashes green.
3. Press Reset button to exit test.



Manual Run Cycle

To run additional Run Time, push the button.

Manifold

There are two manifold sizes:

- 6 port manifold - use in lubrication systems with 6 or less lubrication points (FIG. 39 and FIG. 41).
- 12 port manifold - use in lubrication systems with 7 to 12 lubrication points (FIG. 39 and FIG. 40).

Parts: 6 port models

Ref	Part No	Description	Qty
101		INJECTOR (see Injector Parts, page 56)	
119	25C988	MANIFOLD, 6 port	1
121		STEM, manifold	1
122		NUT	1
123		WASHER	1
124		O-RING	1
126	24Z808	PLUG with O-Ring, manifold	

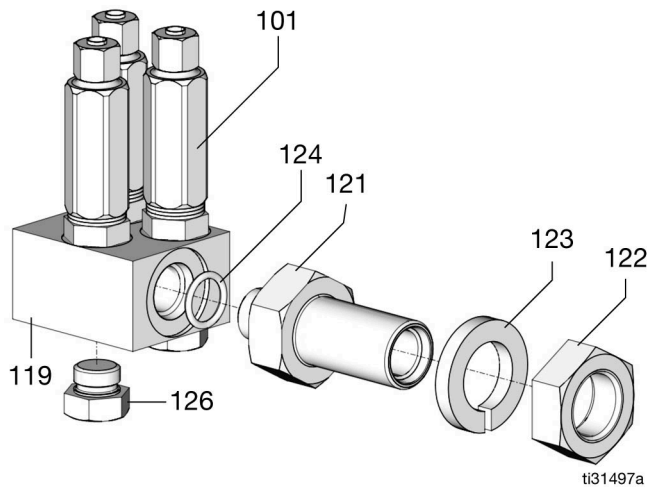

FIG. 39

Parts: 12 port models

Ref	Part No	Description	Qty
101		INJECTOR (see Injector Parts, page 56)	
120	25C989	MANIFOLD, 12 port	1
121		STEM, manifold	1
122		NUT	1
123		WASHER	1
124		O-RING	1
125	129752	PLUG, cap, hex head	2
126	24Z808	PLUG with O-Ring, manifold	

*In FIG. 40 the Manifold Stem (121) is shown installed in the bottom port. It can also be installed in the side ports.

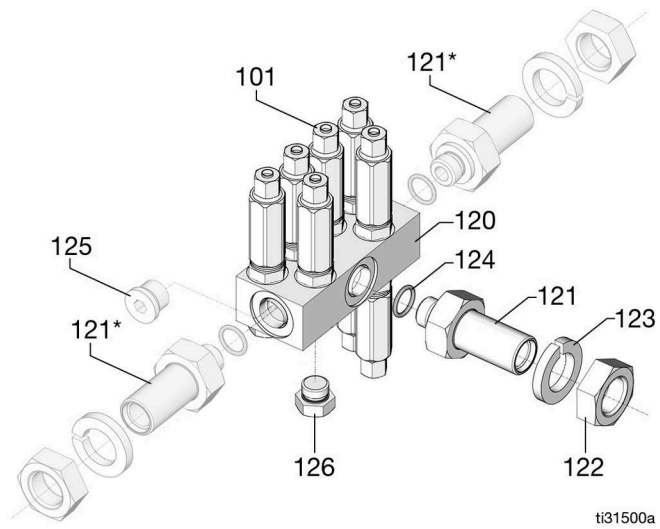

FIG. 40

Manifold Dimensions

6 Point Manifold Dimensions

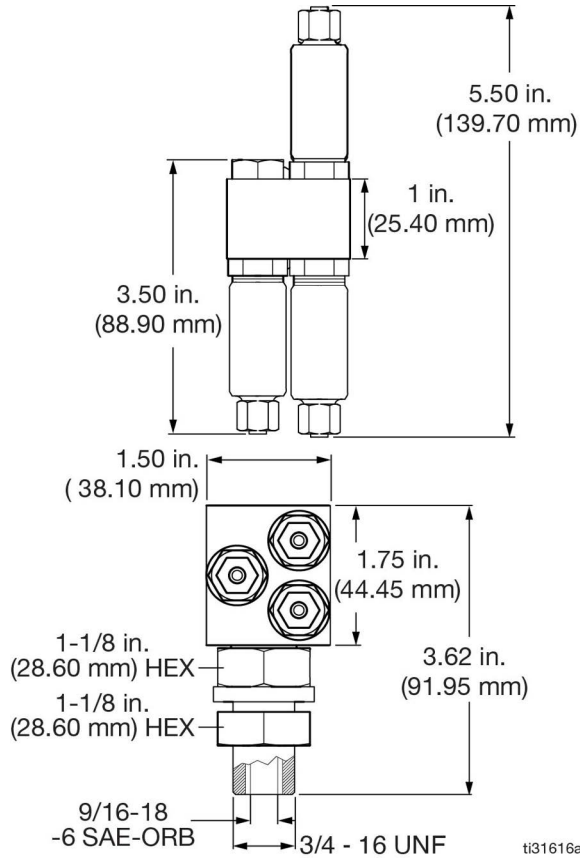

FIG. 41

ti31616a

12 Point Manifold Dimensions

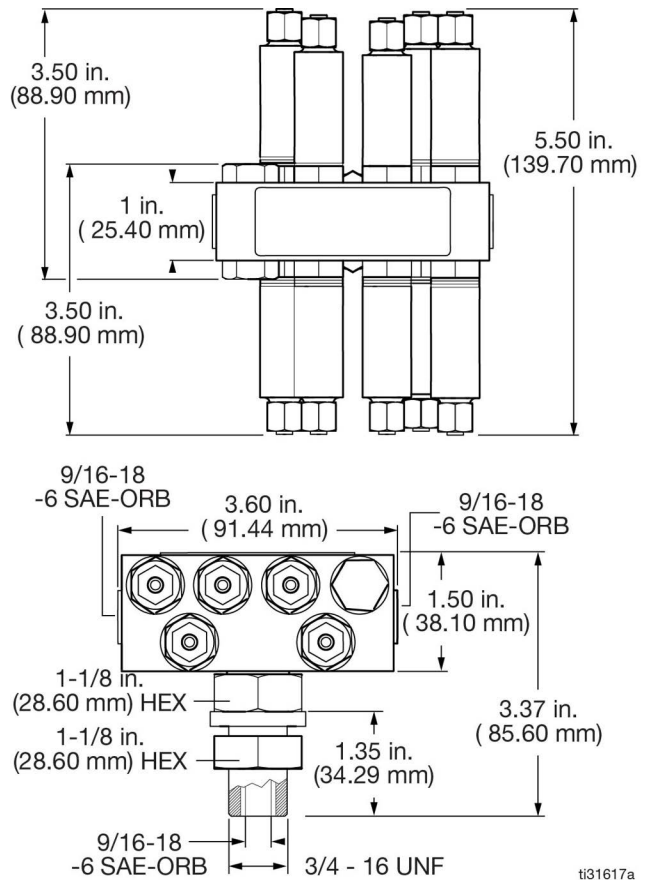

FIG. 42

ti31617a

Injector Manifold Assembly

Injector outputs can be combined for a common bearing point with a large grease requirement, but the output for a single injector cannot be split into multiple bearing points.

1. Install the manifold stem (121) and o-ring (124) in the inlet port of the injector manifold (119 or 120) (FIG. 39 and FIG. 40, page 54).

NOTE: The inlet port on the 12 point manifold (120) can be installed in the side or top inlet port.

2. Use plugs (126) to block any ports not used in the injector manifold (FIG. 39 and FIG. 40, page 54). Be sure the o-ring is installed on the plug. If additional lube points are needed, these plugs can be removed and replaced with appropriate sized injectors and lube lines.

Injectors

Parts

Ref	Part No	Description	Qty
101		SEAL, gasket	1
102		BODY, injector	1
103		CUP, retaining	1
104	556586	O-RING, 5-058	1
105	556660	NUT, sleeve assembly, 3/16 tube	1
110	557898	SPACER, output, model 24Z682; injector size #0	0
		SPACER, output, model 24Z683; injector size #1	1
		SPACER, output, model 24Z684; injector size #2	2
		SPACER, output, model 24Z685; injector size #3	3
		SPACER, output, model 24Z686; injector size #4	4
		SPACER, output, model 24Z681; injector size #8	4
112		SPRING, compression	1
114		BODY, valve	1
117		O-RING	1

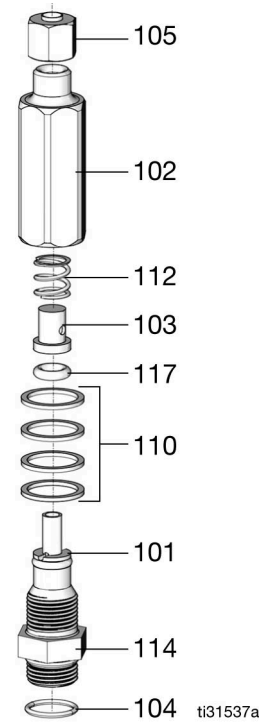

FIG. 43

Injector Dimensions

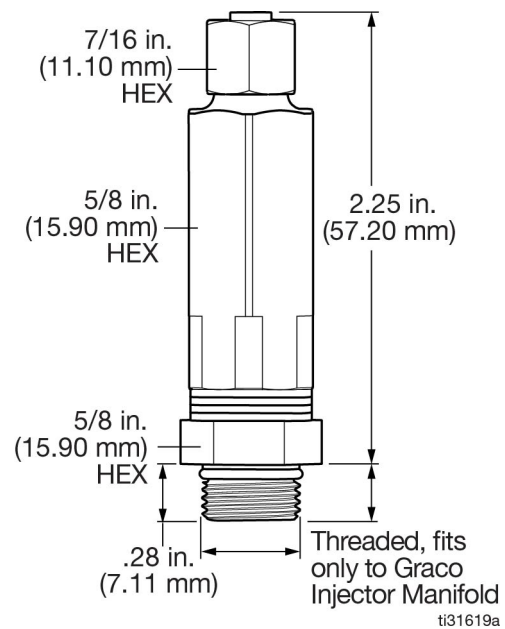

FIG. 44

Adjust the Grease Output Volume

Grease injectors provide precise lubrication to each grease point in the system. If an injector is not producing the correct amount of lubricant for a specific location on the vehicle, or if a replacement injector of correct size is not available, output spacer washers (110) can be installed to adjust the injector output volume (FIG. 43, page 56).

Use the Injector Identification and Usage Table to determine which size injector is appropriate for the grease location.

Injector Identification and Usage				
Part No.	Injector Size	Number of Washers	Output (in. ³)	Recommendations for Specific Lubrication Points
24Z682	0	0	0.002	Brake Shafts, transmissions, cross shafts, S cams
24Z683	1	1	0.005	Slack adjusters, 5th wheel pivot, and miscellaneous points
24Z684	2	2	0.009	Drag link, tie rod ends, power steering linkage
24Z685	3	3	0.012	King pins, spring pins, spring shackles
24Z686	4	4	0.015	Miscellaneous points
24Z681	8*	4	0.026	5th Wheel plate

**Size 8 high output injectors cannot be changed.*

To change output volume:

1. If the injector is installed in the manifold:
 - a. Follow the **Pressure Relief Procedure**, page 6.
 - b. Remove the feed line. Use a 5/8 in. deep well socket to remove the injector (101) from the manifold (119/120) (FIG. 45).

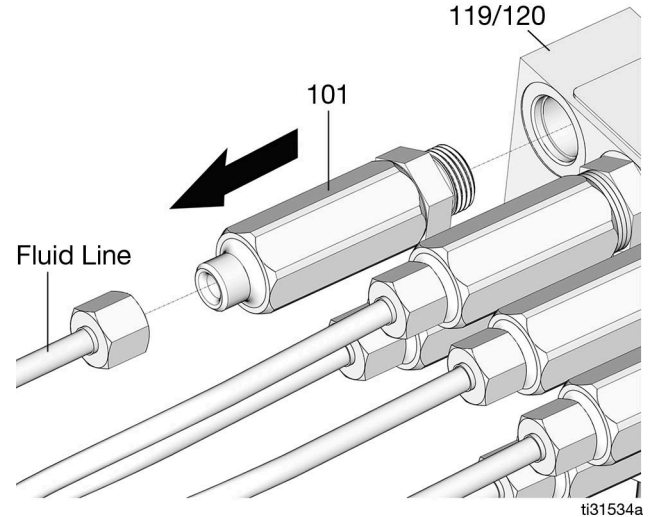

FIG. 45

For all injector adjustments:

- Place the injector (101) in a vise with the outlet end (tube connector) facing up.

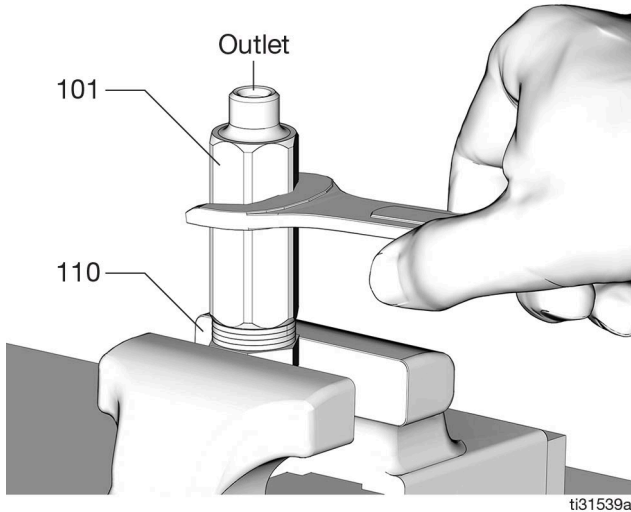

FIG. 46

- Use a 5/8 in. wrench to loosen and separate the injector body (102) from the valve assembly (114). Be careful not to misplace or damage the spring (112), retainer cap (103), and o-ring (117) (FIG. 43, page 56).
- Add or remove output spacers (110) (FIG. 46) from the injector valve assembly.

NOTE:

- Add spacers (110) to increase output volume.
- Remove spacers (110) to decrease output volume.

- Reassemble the injector valve assembly. Make sure that all parts removed during disassembly are reinstalled in the correct order as shown in FIG. 43 (page 56). Use a 5/8 in. wrench to tighten, using only enough force to seat the output spacers firmly (110). Torque to 8 ft-lb +/- 2 (10.8 +/- 2.7 N•m).
- Install injector (101) onto manifold (119/120). Slide a deep well socket over the injector and aligned with the hex nut flats (114) (FIG. 43, page 56). Torque to 8 ft-lb +/- 2 (10.8 +/- 2.7 N•m).

Manifold Installation

- Mount all injector manifolds on the vehicle frame rail, or a cross member, close to the lubrication points.
- Install injectors in locations that allow easy and safe servicing access.
- Install injectors in areas that minimize accidental injector damage by moving equipment.
- The unused ports in the manifolds should have plugs in them. If additional lube points are needed, these plugs can be removed and replaced with appropriate sized injectors and lines.
- Group injectors to minimize feed line length.

- Drill a 13/16 in. (20.65 mm) mounting hole through the frame rail or cross member.
- Slide the manifold stem (121) through the hole (make sure the injectors are facing the lubrication points) (FIG. 47).
- Slide the washer (123) over the stem, and screw nut (122) onto the stem (FIG. 47). Torque nut to 22 ft-lbs (29.83 N•m).

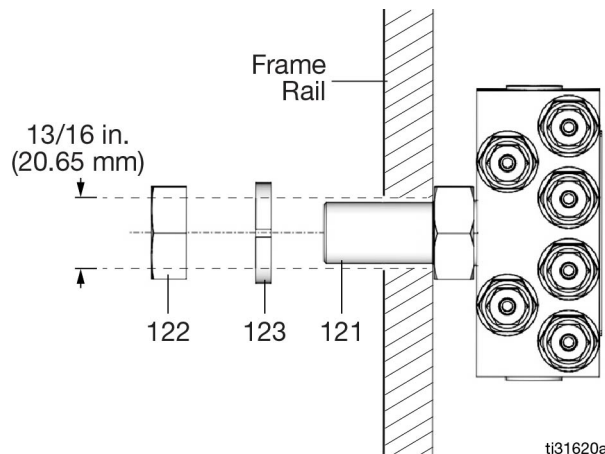
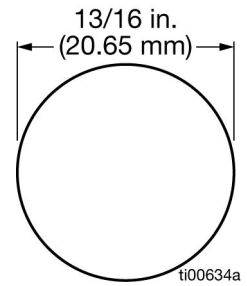

FIG. 47

Modules

NOTE: All installations may not include all of the points listed. The illustrations and instructions shown in the Modules section are provided for reference only. They may not be an exact representation of the truck or equipment. Lubrication points and locations are unique to each vehicle and installation will vary from vehicle to vehicle.

Front Left Module (FIG. 48)

Point No.	Description	Injector Size	Tube Color	Bundle	Recommended Lube Point Fitting P/N
1	KING PIN UPPER	3	Orange	3-Tube	556638 Elbow
2	TIE ROD	2	Black		15K740 Elbow and 556644 Connector
3	KING PIN LOWER	3	Blue		556638 Elbow
4	DRAG LINK	2	Orange	2-Tube Unmarked	15K740 Elbow and 556644 Connector
5	DRAG LINK	2	Black		15K740 Elbow and 556644 Connector
6	SPRING PIN	3	Black	Single	556638 Elbow
7	PLUG				
8	PLUG				
9	SLACK ADJUSTER	1	Orange	2-Tube #2	556638 Elbow
10	"S" CAM	0	Black		556638 Elbow
11	SPRING SHACKLE	3	Black	2-Tube #1	556638 Elbow
12	SPRING SHACKLE	3	Orange		556638 Elbow

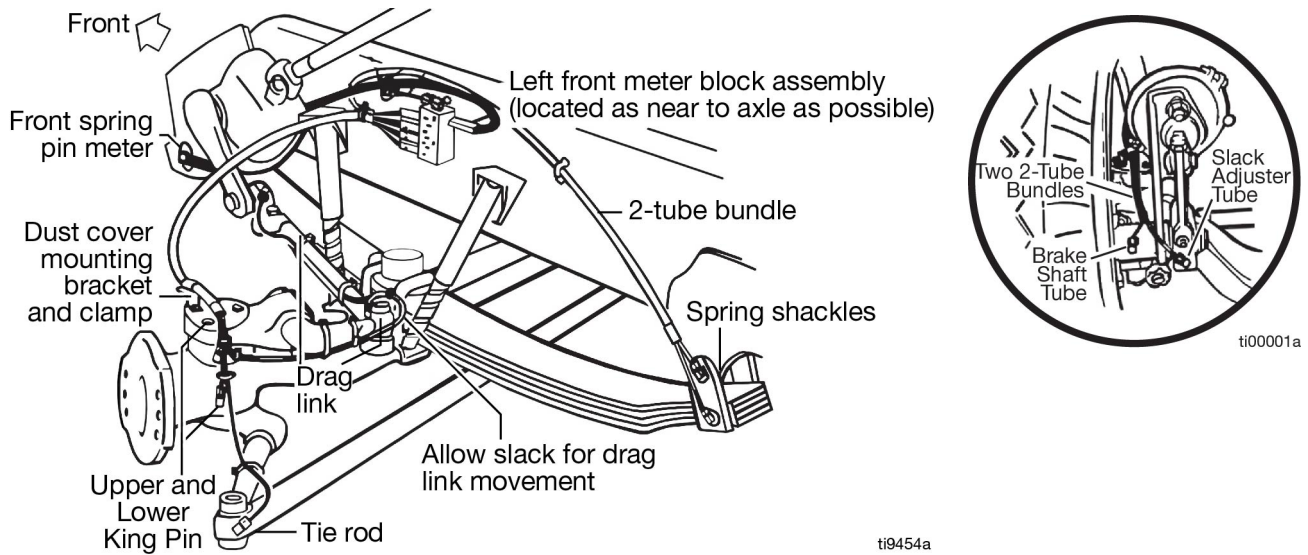

FIG. 48

Installation Instructions

1. Tie wrap the 3-tube bundle, 2-tube bundle and (2-tube #2, if present) marked bundle together as a group. These follow the air brake line over the wheel area.
2. Use double-strap ties (Part No. 25C980) to attach the tube to the air brake line. The strap should be snug, but not overtightened.
3. Anchor the first tie at the frame fitting and the last tie of this bundle at the fitting on the brake can. This prevents strain on the air hose.
4. Connect the upper king pin first.
5. When routing the lines to the lower king pin and tie rod connection, make sure there is clearance away from the wheel.
6. Tie the tie rod line (black) to the lower king pin fitting after the connection is made. Route the line up and over the tie rod arm to loop over the rear of the tie rod end. This reduces the chance of the line being snagged by road debris.
7. Run spring hanger lube lines along the side of the frame, attaching every 12-15 in. After attaching the first line to the upper fitting, secure the other lube line to that fitting, then connect into the lower spring hanger. This assures that the lube line will travel with the hanger.
8. Route the lube line for the spring pin (black, single) so it will be supported every 12-15 in. of travel.
9. The inlet for the module is through the stud. Use an elbow (Part No. 129755) or tee (Part No. 129759), depending on the routing of the main line. Alternate ports are on each end of the module.
10. **Optional:** Ports 7 & 8 on the modules are used for additional lube points. i.e., rear spring or clutch linkage.

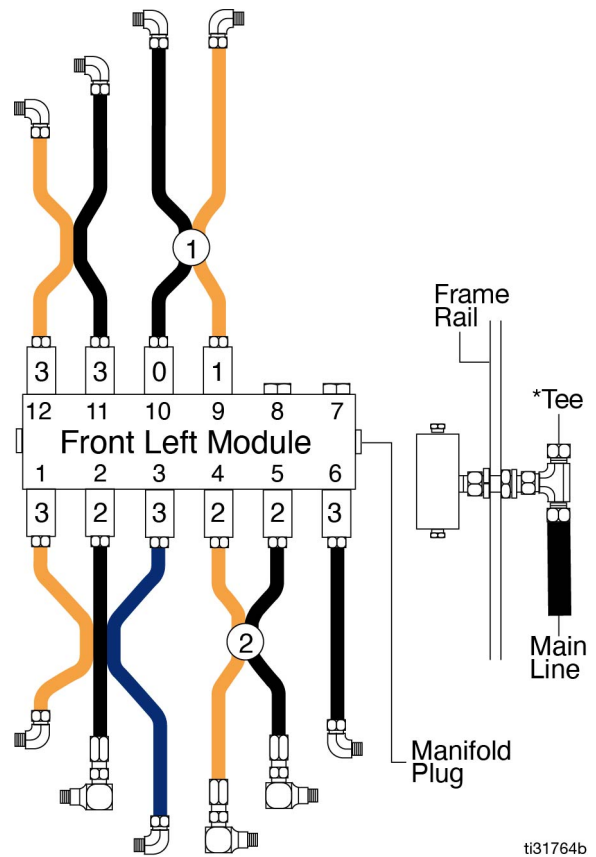

FIG. 49: *Tee 129759 shown. Can also use elbow 129755

Front Right Module (FIG. 50)

Point No.	Description	Injector Size	Tube Color	Bundle	Recommended Lube Point Fitting P/N
1	SPRING SHACKLE	3	Orange	2-Tube #1	556638 Elbow
2	SPRING SHACKLE	3	Black		556638 Elbow
3	PLUG				
4	PLUG				
5	CLUTCH C/SHAFT LH	0	Black	2-Tube Unmarked	15K783 St Elbow and 556644 Connector
6	CLUTCH C/SHAFT RH	0	Orange		556638 Elbow
7	SPRING PIN	3	Black	Single	556638 Elbow
8	SLACK ADJUSTER	1	Orange	2-Tube #2	556638 Elbow
9	"S" CAM	0	Black		556638 Elbow
10	KING PIN LOWER	3	Blue	3-Tube	556638 Elbow
11	TIE ROD	2	Black		15K740 Elbow and 556644 Connector
12	KING PIN UPPER	3	Orange		556638 Elbow

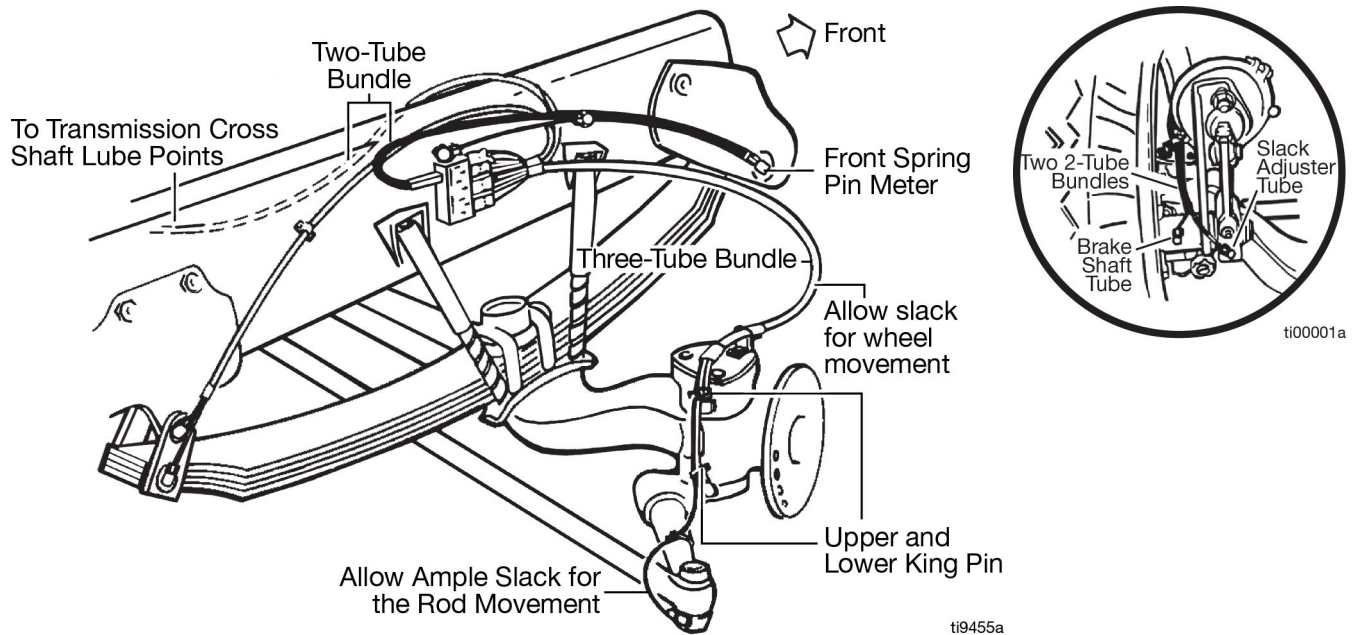

FIG. 50

Installation Instructions

1. Tie wrap the 3-tube bundle and 2-tube #2 marked bundle together as a group. These follow the air brake line over the wheel area.

NOTE: Skip Step 1 if there is not a 2-tube #2 tube bundle required for the installation.

2. Use double-strap ties (Part No. 25C980) to attach the tube to the air brake line. The strap should be snug, but not overtightened.
3. Anchor the first tie at the frame fitting and the last tie of this bundle at the fitting on the brake can. This prevents strain on the air hose.
4. Connect the upper king pin first.
5. When routing the lines to the lower king pin and tie rod connection, make sure there is clearance away from the wheel.
6. Tie the tie rod line (black) to the lower king pin fitting after the connection is made. Route the line up and over the tie rod arm to loop over rear of the tie rod end. This reduces the chance of the line being snagged by road debris.
7. Run clutch lines under or through the frame rail. Allow enough slack in the line for drive train movement. The left cross shaft lube point may be easier to access by removing the floor panel around the shift base.
8. Run spring hanger lube lines along side of frame, attaching every 12-15 in. After attaching the first line to the upper fitting, secure the other lube line to that fitting, then connect into the lower spring hanger. This assures that the lube line will travel with the hanger.
9. Route the lube line for the spring pin (black, single) so it will be supported every 12-15 in. of travel.
10. The inlet for the module is through the stud. Use an elbow (Part No. 556639) or tee (Part No. 556636) depending on the routing of the main line. Alternate ports are on each end of the module.
11. **Optional:** Ports 3 or 4 on the module are used for additional lube points. i.e., rear spring, assisted steering, throw out bearing.

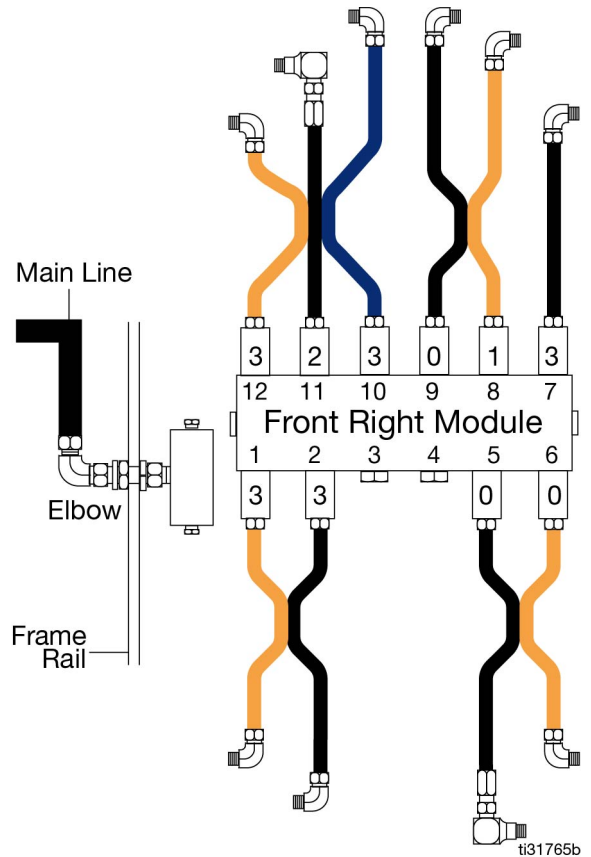

FIG. 51

Tandem Axle Module (FIG. 52)

Point No.	Description	Injector Size	Tube Color	Bundle	Recommended Lube Point Fitting P/N
1	PLUG				
2	PLUG				
3	"S" CAM	0	Black	2-Tube	556638 Elbow
4	SLACK ADJUSTER	1	Orange	Unmarked	
5	"S" CAM	0	Black	2-Tube	
6	SLACK ADJUSTER	1	Orange	Unmarked	
7	SLACK ADJUSTER	1	Orange	2-Tube	
8	"S" CAM	0	Black	Unmarked	
9	SLACK ADJUSTER	1	Orange	2-Tube	
10	"S" CAM	0	Black	Unmarked	
11	PLUG				
12	PLUG				

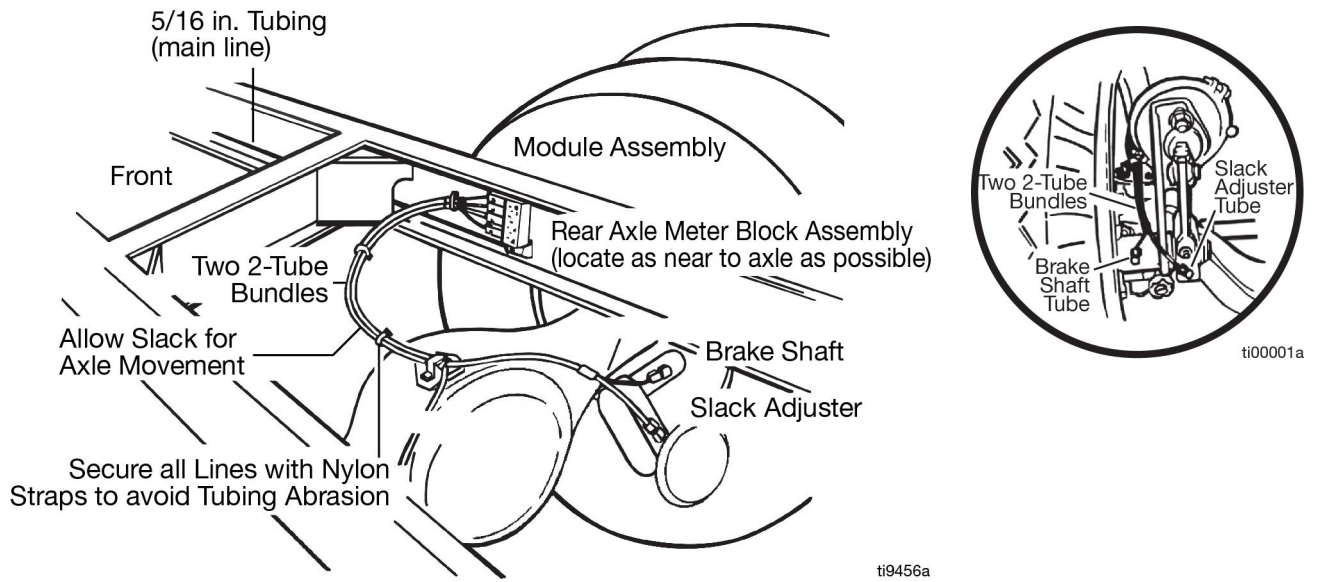

FIG. 52

Installation Instructions

1. Run each twin line to the brake slack adjuster and S cam following the air hoses from the control valve to the brake cams. This allows for enough slack in the lines for axle movement.
2. Use double-strap ties (Part No. 25C980) to attach tube to the air brake line. Strap should be snug, but not overtightened.
3. Make sure that the orange lines going to the slack adjusters have enough of a loop to allow movement of the actuator.
4. The main line connection is through an elbow (Part No. 556639) at one end. There may be a plug in the other end, another elbow or a straight fitting to allow grease to the next module.

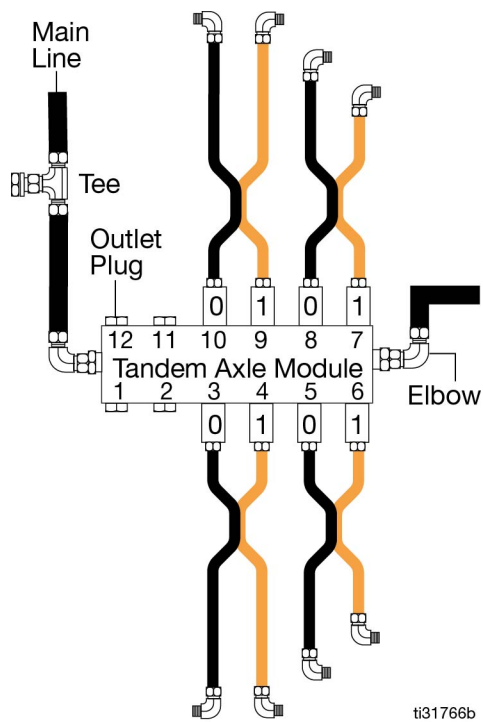

FIG. 53

5th Wheel Module (FIG. 54)

Point No.	Description	Injector Size	Tube Color	Bundle	Recommended Fitting P/N
1	FIFTH WHEEL PLATE	8	Orange	3-Tube	556644 Connector or 556638 Elbow
2	FIFTH WHEEL PIVOT	1	Black		
3	FIFTH WHEEL PLATE	8	Blue	3-Tube	
4	FIFTH WHEEL PLATE	8	Blue		
5	FIFTH WHEEL PIVOT	1	Black		
6	FIFTH WHEEL PLATE	8	Orange		

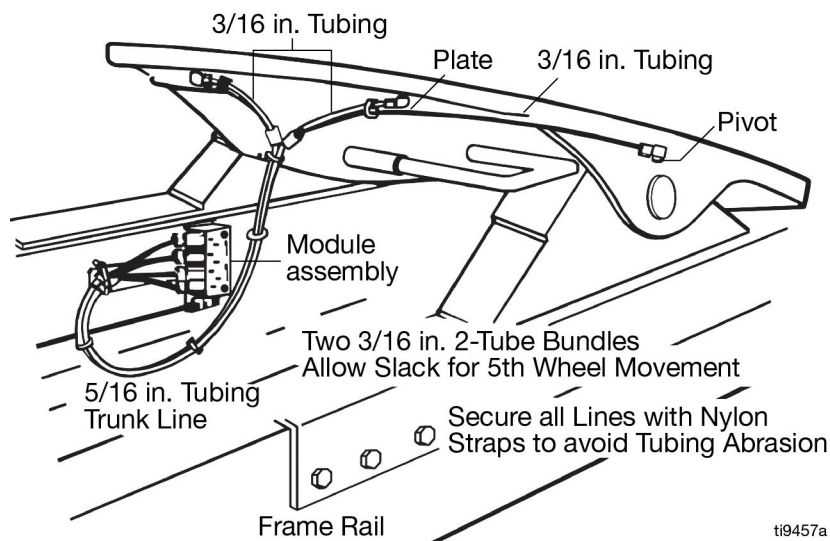

FIG. 54

Installation Instructions

1. Run the orange lines and the blue lines to the plate and the black lines to the pivot points. If there are more than 2 ports on the pivots, only 2 require auto lube.
2. Make sure that the lines do not rub on the 5th wheel, or its mounting components; the tubing can be pinched or wear through.

NOTE: Wrap the tubes with corrugated sheathing (user supplied) to protect the tube from rubbing.

3. The main line connection is through an elbow (Part No. 556640) at one end. There may be a plug in the other end, another elbow or a straight fitting to allow grease to the next module.

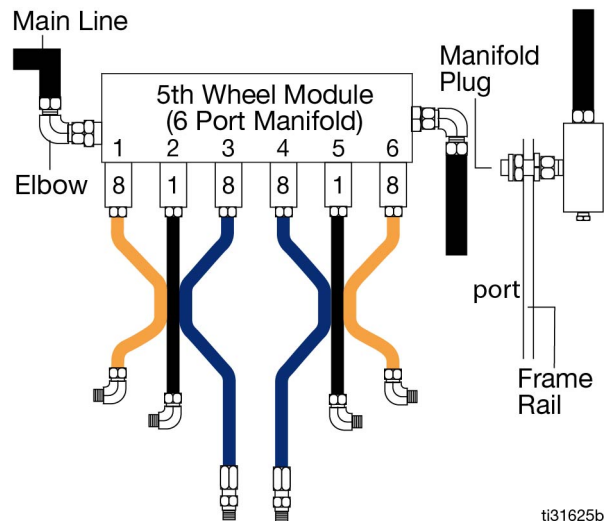

FIG. 55

Feed Line Tubes and Fittings

Feed Line Tubes (H)

Feed line tubes (H) come pre-filled with grease. The tube bundles in the table may be included with the system. Other tube lengths are available. Contact your local Graco distributor or Graco Customer Support for assistance.

Part No.	Bundle 10 feet (3.04 meters)	Bundle 15 feet (4.57 meters)	Color
564086	1 tube		Black
563984	2 tubes		Black, Orange
563994	3 tubes		Black, Orange, Blue
563786		1 tube	Black
563788		2 tubes	Black, Orange
563783		3 tubes	Black, Orange, Blue

Feed Line Installation

NOTICE

- When installing the fluid lines avoid routing them close to a heat source such as an exhaust manifold, muffler, turbocharger, etc. Exposure to heat will damage the fluid lines.
- Non-approved nylon or air brake tubing should not be used. Only use the supplied fluid lines. Non-approved nylon or air brake tubing may not be designed for exposure to heat or excessive abrasion which can result in erosion, snagging or cutting of the tubing.

Always use approved 3/16 in. (4.76 mm) OD tubing. The 3/16 in. (4.76 mm) tubing comes in three configurations.

- Single tubes: Black.
 - 2 tube bundles: Black with a black and orange tube inside sheath.
 - 3 tube bundle: Black, blue and orange tube inside a sheath.
- The orange tube is connected to the highest output injector.
 - The blue tube is connected to a lesser or equal output injector.
 - The black tube is connected to the lowest or equal output injector of the bundle group.

General Installation Instructions

NOTE: For specific installation instructions for the Module, see Left Front, Right Front, Rear and 5th Wheel Modules instructions beginning on page 59.

1. Measure the approximate lengths of fluid line tubes (H), leaving extra length for trimming at the lube points.

NOTE: Allow ample slack for tube movement and ease of installation

2. Align fluid line with the fitting.
3. Cut the tube with a tubing cutter.
4. Insert the end of the fluid line tube into the injector ferrule (FIG. 56).

NOTE: A self aligned ferrule is supplied with all 3/16 in. (4.76 mm) fittings. It is not necessary to remove the nut and ferrule to seat the tube into the fitting.

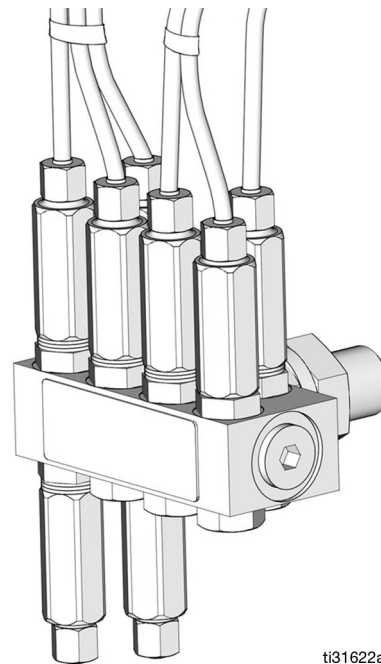

ti31622a

FIG. 56

5. Make sure the tube is well seated into each fitting.

Hand tighten the tube nut onto the injector and tighten 1 full turn beyond hand tight. Do not over tighten (FIG. 57).

NOTE: Tube nuts can be loosened and re-tightened a maximum of 8 times after the initial tightening. When re-tightening, only tighten 1/8 turn beyond hand tight.

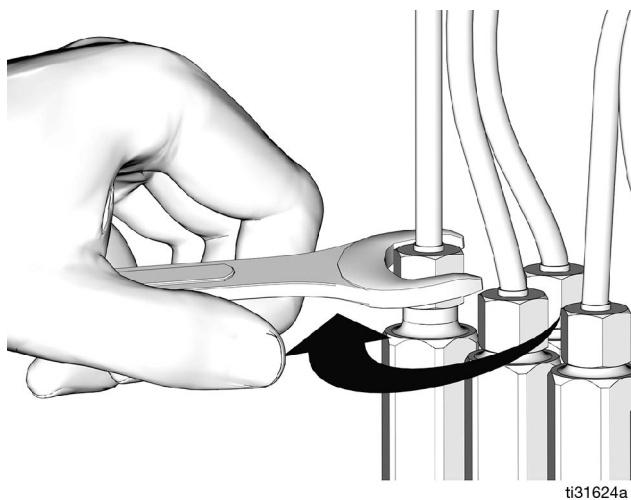

FIG. 57

Feed Line Fittings

Straight Connector - Part No. 556644

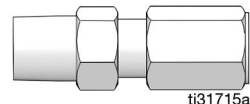

FIG. 58

Elbow Connector - Part No. 556638

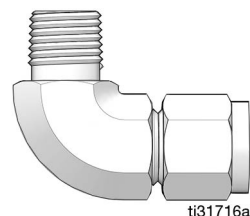

FIG. 59

Street Elbow - Part No. 15K740

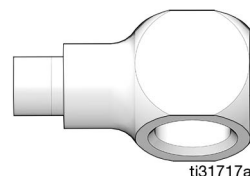

FIG. 60

Street Elbow - Part No. 15K783

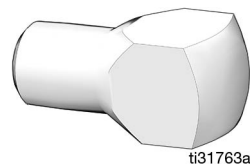

FIG. 61

Main Line Hose

Temperature

Do not exceed the fluid or ambient temperature specifications of the hose. The approved temperature range for the hose is -56°F to 302°F (-49°C to 150°C).

Routing

NOTICE

- When installing the fluid lines avoid routing them close to a heat source such as an exhaust manifold, muffler, turbocharger, etc. Exposure to heat will damage the fluid lines.
- Route hoses to minimize exposure to hazards. Do not expose the hose to excessive abrasion which can result in erosion, snagging or cutting of the hose cover.
- Non-approved air brake hoses should not be used. Only use the supplied fluid lines. Non-approved air brake hoses may not be designed for exposure to heat or excessive abrasion which can result in erosion, snagging or cutting of the hose cover.
- Do not install in a location where the hose could be kinked, crushed or flattened.
- Do not create a bend radius smaller / tighter than 4 inches (101 mm).

Route hoses to ensure the relative motion of the equipment bends the hose. Do not allow the hose to twist.

Pressure Rating

2250 psi (15.5 MPa, 155.1 bar).

End Fitting

37-degree JIC, 9/16-180 UNF swivel.

Determine the Main Line Hose Lengths

Hoses are available in three lengths. One end is crimped in the factory, the other end comes with a reusable fitting.

Part No.	Length
17S968	6 feet (1.82 meters)
17S969	12 feet (3.65 meters)
17S970	18 feet (5.48 meters)

After determining the final length of hose needed for the installation, connect the reusable swivel fitting (Part No. 131200), included with the hose, to the bare end of the hose (FIG. 62). Follow the Main Hose Assembly instructions in the **Main Line Hose Assembly**, page 69.

To determine the overall length of hose needed for each fluid line:

1. Measure the distance between the pump and the injectors.
2. Add an additional 2 percent to the hose length to accommodate for change in length due to pressurizing the hose. The hose length shrinks when the hose is pressurized.

Example: A 100 in. (2.54 m.) hose shrinks to 98 in. (2.49 m) when pressurized.

3. Add 1.43 in. (36.30 mm) to the total hose length to accommodate the depth of the socket after it is installed on the end of the hose (FIG. 62).

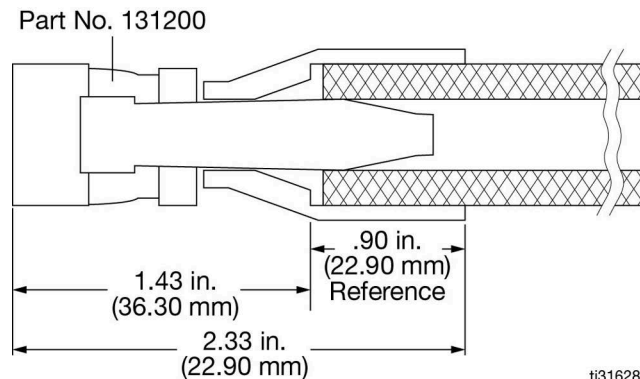

FIG. 62

Main Line Hose Assembly



SKIN INJECTION HAZARD

A hose that has been crushed or damaged in the vise may leak. High pressure fluid leaks will pierce skin. This may look like just a cut, but it is a serious injury that can result in amputation. Get immediate surgical treatment.

To reduce the risk of skin injection when testing or using the hose assembly:

- Inspect each hose assembly for cuts or damage.
- Verify that the hose assembly has not been crushed or damaged in the vise.
- Do not use a damaged hose assembly.

1. Secure end of hose in a vise (FIG. 63).

NOTE: Do not over tighten the vise and crush the hose. The vise should just be tight enough to hold the hose securely in place.

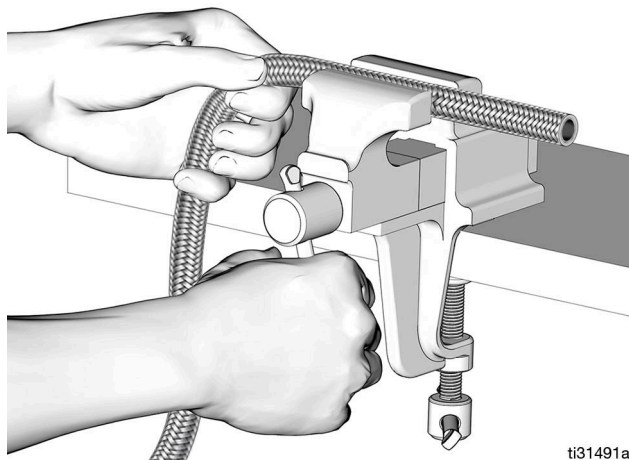

FIG. 63

ti31491a

2. Cut the hose square with a fine-tooth hacksaw or a cut-off wheel (FIG. 64).

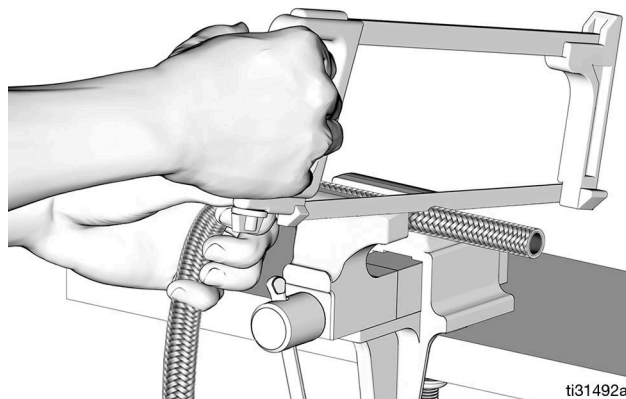

FIG. 64

ti31492a

3. Remove the hose (b) from the vise. Shake, or lightly tap, the cut end to remove debris and small hose pieces that result from cutting the hose.
4. Slide the socket (a) over the cut end of hose (b). Hand tighten the socket to hose by turning the socket counter-clockwise into hose (FIG. 65).

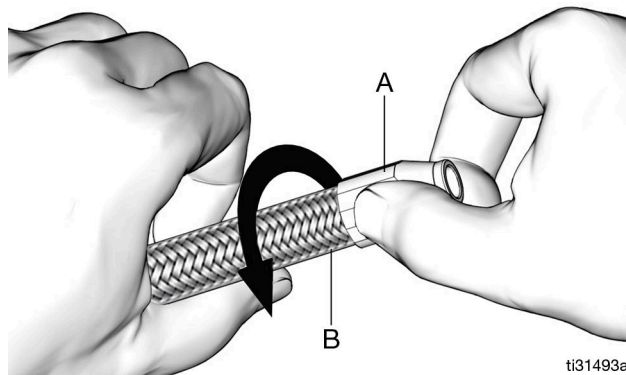

FIG. 65

ti31493a

5. Use a wrench to finish tightening the socket (a) until it bottoms out. Then back off 1/4 turn to 1/2 turn (FIG. 66).

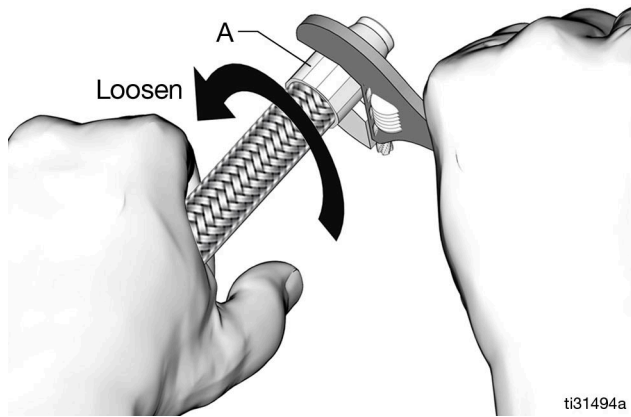

FIG. 66

6. Secure the socket (a) in the vise. Lubricate the nipple (c) and threads liberally with grease.

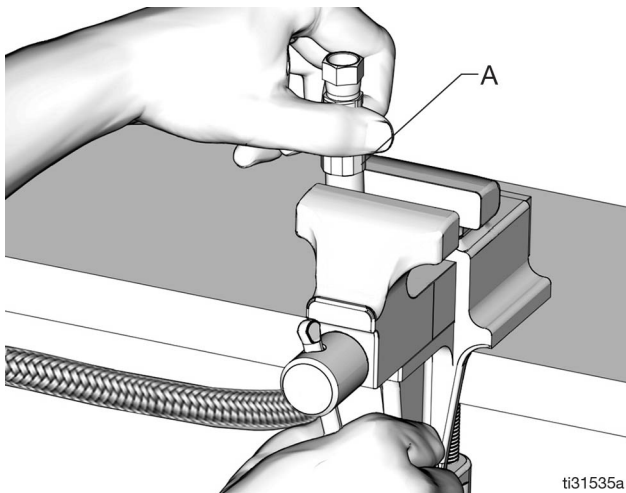

FIG. 67

7. Lightly push the nipple (c) into the socket (a). Screw the nipple clockwise into the socket and hose (FIG. 68).

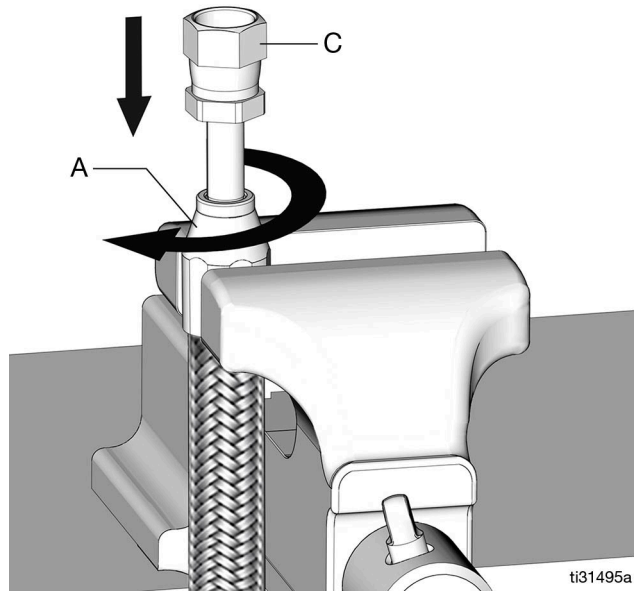

FIG. 68

8. Leave 1/32 in. to 1/16 in. (0.79 mm to 15.87 mm) clearance between the socket (a) and the hex (d) (FIG. 69).

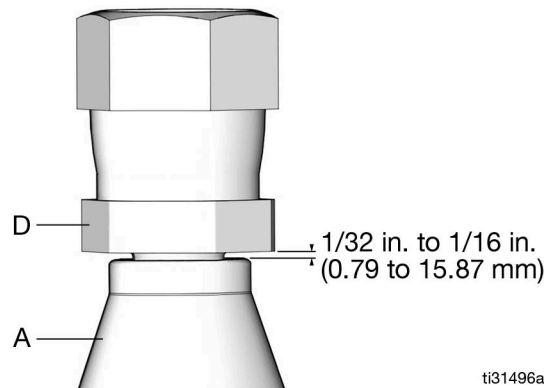

FIG. 69

Main Line Fittings

Straight Connector - Part No. 129763

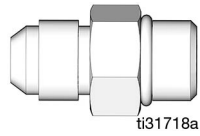

FIG. 70

Elbow Connector - Part No. 129755

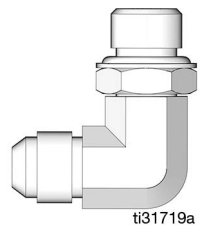

FIG. 71

Tee Fitting- Part No. 129759

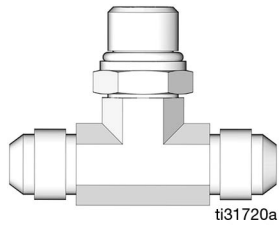

FIG. 72

Start the System and Operation

<p>AUTOMATIC SYSTEM ACTIVATION HAZARD</p> <p>The system is equipped with an automatic timer that activates the pump lubrication system when power is connected or when exiting the programming function. Unexpected activation of the system could result in serious injury, including skin injection and amputation.</p> <p>Before you install or remove the lubrication system components from the system, disconnect the battery and isolate all power supplies and relieve all pressure.</p>				

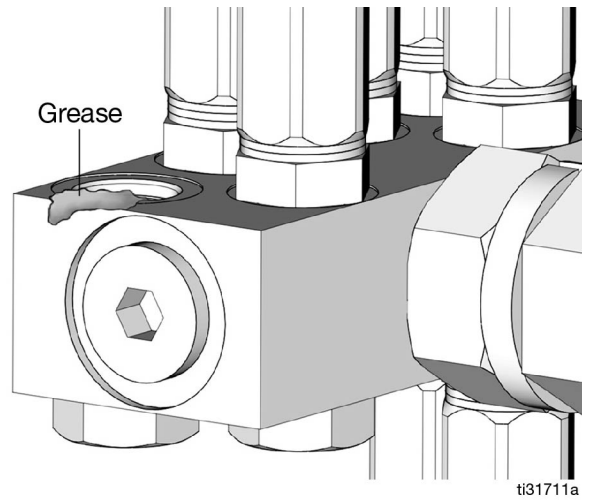

FIG. 73

Start the System

The system is ready to start after installation of the pump, main line, feed line, and modules.

Fill the Main Line



An automatic lubrication system must be free of air to generate enough pressure to discharge grease from the injectors. The main feed line must be filled with grease.

1. Remove a plug or injector from the top of each manifold assembly. Place a rag below the injector to capture excess grease.
2. Start the pump.
3. Watch for grease to come out of the manifold from the open outlet port (See Step 1). Allow grease to flow out of the port for up to one minute to be sure that the grease is free of air and flowing freely.

4. Stop the pump.
5. Reinstall the injector into the outlet port. Torque to 8 ft-lb +/- 2 (10.8 +/- 2.7 N•m).
6. The system is ready.

Operation

The following steps describe a typical lubrication cycle.

1. The pump starts.
2. The paddle stirs the grease in the reservoir.
3. The vent valve closes. Pressure builds in the system to approximately 1900 psi (13.1 MPa, 131 bar) and dispenses grease to all injectors in the system and provides lubrication to all of the lubrication points on the vehicle.

NOTE: The controller is factory set to 7 minutes ON time. This provides the pump with time to reach the maximum pressure; approximately 1900 psi (13.1 MPa, 131 bar).

4. If there is any additional ON time (time remaining after building to approximately 1900 psi (13.1 MPa, 131 bar)) the relief valve opens, and relieves pressure from the system back to the reservoir.
5. After the pump stops pumping grease. The vent valve opens and allows the grease and pressure in the fluid lines to flow back into the pump reservoir. The injectors reset.

- The pump rests (OFF time) for 2 hours and 53 minutes.

NOTE: This the factory set OFF time.

- The cycle repeats.

NOTE: See **Program the Pump**, page 25 for instructions to increase or decrease cycle time.

Typical Cycle

The illustration shown in FIG. 74 shows a typical pump cycle.

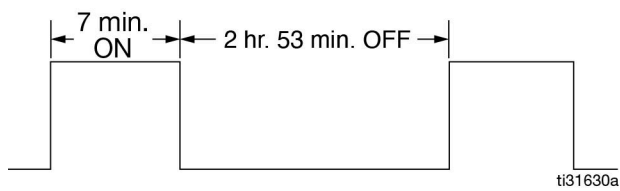

FIG. 74

Troubleshooting



Problem	Cause	Solution
Too much grease at all lube points	Lube cycle too frequent	Increase pump OFF/rest time.
Too much grease at one lube point	Injector is leaking	Remove and replace injector
Not enough grease at all lube points	Lube cycle is too infrequent	Decrease pump OFF /rest time.
No sign of fresh grease at all points	No grease, pump low level	Fill pump.
	Blown fuse or break in wiring circuit. Pump not working.	Check for electrical short circuit or broken wire, and repair.
	Main line broken	Check and replace Main Line Hose.
	Worn pump element and/or vent valve.	Using a 2500 psi (17.24 MPa, 172.4 bar) pressure gauge, check for pressure. The pump pressure should build to approximately 1900 psi (13.1 MPa, 131 bar). If it does not reach approximately 1900 psi (13.1 MPa, 131 bar) replace pump element and/or vent valve.
No sign of fresh grease at some lube points	Main line broken	Check and replace main line hose.
	Air lock in main line	Purge air from main line; page 72.
No sign of fresh grease at one lube point	Feed line damaged	Replace feed line.
	Injector inoperative	Replace injector.
	Lube point fitting has broken off	Remove broken fitting and replace
Main line damaged	Trapped and broken, rubbed through	Replace (re-route and/or protect the line to prevent the damage from happening again). Purge with grease to expel air before connecting new main line into system.
Feed line damaged	Hose is kinked, pinched, broken or punctured	Replace (re-route and/or protect the line to prevent the damage from happening again).
	Feed line has detached out of fitting	Refit line to the fitting using a new compression nut.
	Broken or damaged feed line fitting	Remove broken fitting and replace.
Unit does not power on	Incorrect/loose wiring	Refer to Installation instructions, page 6.
	Tripped external fuse due to internal component failure	Replace pump.

Problem	Cause	Solution
Pump runs continuously	Pump is not wired correctly	Check wiring. See Pump Wiring, page 16. Check for short circuit.
Can't set desired ON/OFF times	Maximum duty cycle is 33 percent (2 minutes OFF for each minute ON)	Adhere to allowable duty cycle.
Unit is not operating based on the time that was programmed	Time entered was misinterpreted as MM:SS instead of HH:MM (or visa versa)	Verify the unit was programmed as intended. See Program the Pump page 25. Note the dot designation for hours, minutes, seconds on the top row of the display.
Lubricant leaks past seal located on the bottom of the reservoir	Reservoir retaining tabs are cracked or broken	Replace reservoir.
	Reservoir is being pressurized during filling	Ensure vent hole is not plugged.
	Reservoir is being pressurized during filling due to rapid filling or overfilling reservoir	Ensure vent hole is not plugged. Fill reservoir slowly. Do not overfill reservoir and main line hose.
Pump stirring paddle is not rotating and pump is not pumping during ON cycle, but controller lights and functions	Failed motor	Replace pump.
Pump takes several minutes before it begins pumping	Pumping non-cold weather lubricant in cold weather	Adjust lube cycle time to accommodate the difference in pump run time. or Replace lubricant in pump, main line hose and fluid lines with a lubricant that is pump-able, rated for environmental conditions and application.
USB Error 00	Flash drive was removed during operation	Keep the flash drive plugged in until the unit has completed the operation.
USB Error 07	Flash drive unable to mount (initialize)	<ul style="list-style-type: none"> • Unplug the flash drive and re-install. • Cycle power and re-install the flash drive. • Retry using a different flash drive. If any of the above do not rectify the error, contact Graco Customer Service.
USB Error 11	Pump program setting file not found	Verify that the pump program setting folder structure and file are stored correctly on the flash drive. See Storing Pump Program Settings to the Flash Drive, page 32 for instructions.

Problem	Cause	Solution
USB Error 12	Pump program settings directory not found.	Verify that the pump program setting folder structure and file are stored correctly on the flash drive. See Storing Pump Program Settings to the Flash Drive, page 32 for instructions.
USB Error 13	Bad pump program settings file	The pump programs settings file is corrupt. Restore file to the flash drive. See Storing Pump Program Settings to the Flash Drive, page 32 for instructions.
	Setting file is from different firmware version	Program pump manually or recreate settings file from a pump that has the same firmware version. See Storing Pump Program Settings to the Flash Drive, page 32.
All other USB errors		<p>The following operations can be attempted if another error occurs using the USB.</p> <ul style="list-style-type: none"> • Unplug the flash drive and reinstall. • Cycle power and re-install the flash drive. • Retry using a different flash drive. <p>If any of the above do not rectify the error, contact Graco Customer Service.</p>



Maintenance

Frequency	Component	Required Maintenance
Daily and at refill	Refill Fitting	Keep refill fitting clean by covering it with dust cap (26) when not in use. Clean refill fitting using a clean dry cloth. Dirt and/or debris can damage pump and/or lubrication system.
Weekly	Pump Unit and Reservoir	Keep pump unit and reservoir clean using a clean dry cloth.
	Display	Keep display clean using a clean dry cloth.
Monthly	External Wiring Harness	Verify external harnesses are secure.
	Lube Points	Open feed line tube and check for fresh grease.
	Pump	Check for operation and grease level in reservoir.

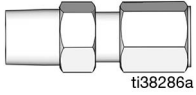
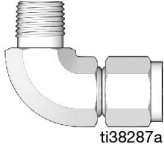
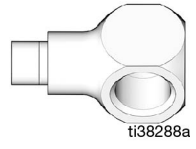

Change Greases

Always verify compatibility before mixing two greases together.

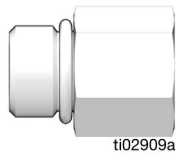
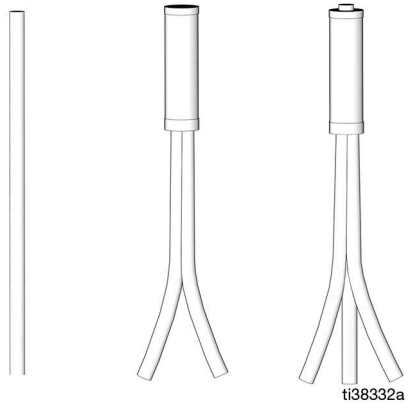
Service Parts

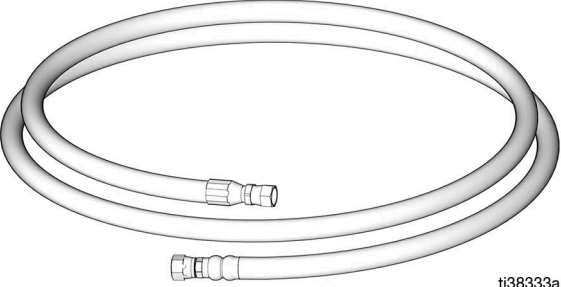
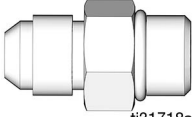
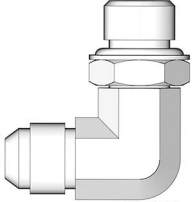
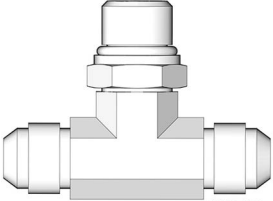
Part No.	Description	Illustration
Lube Point Fittings Brakes, King Pins, Drag Links, Tie Rods, Spring Pins, 5th Wheel		
556644	3/16 in. OD tube to 1/8 NPT straight connectors	
556638	3/16 in. OD tube to 1/8 NPT elbows	
15K740	1/4-28SAE (m) to 1/8 NPT (f) elbow, 90°	
15K783	1/8-, SAE short, elbow, 90°	
556660	Nut, 3/16 in. tube with captive sleeve	
129871	SAE 6 Male to 1/8 NPT female adapter	
15W165	3/16 in. tube 30 ft black, precharged	
564090	2 tube bundle 30 ft, precharged	
563796	3 tube bundle 30 ft, precharged	

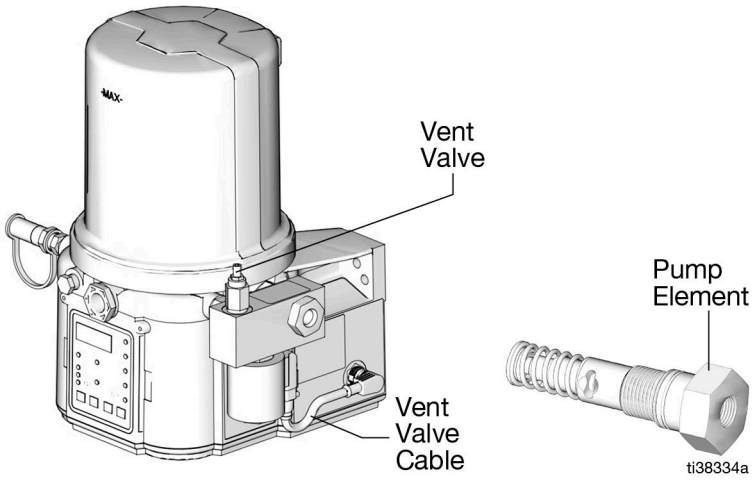
Part No.	Description	Illustration
Mainline Hose and Fitting		
17S968	6 ft (1.8 m) Mainline cut-to-length hose and fitting kit	 <p style="text-align: right; margin-right: 20px;">ti38333a</p>
17S969	12 ft (3.7 m) Mainline cut-to-length hose and fitting kit	
17S970	18 ft (5.5 m) Mainline cut-to-length hose and fitting kit	
129763	Straight connector, 6 ORB x 9/16 37° Flare	 <p style="text-align: center;">ti31718a</p>
129755	90° elbow, 6 ORB x 9/16 37° Flare	 <p style="text-align: center;">ti31719a</p>
129759	Tee fitting, 6 ORB x 9/16 37° Flare (2)	 <p style="text-align: center;">ti31720a</p>

Part No.	Description	Illustration
Pump		
24Z764	12 Volt Standard	
24Z959	24 Volt Standard	
24Z660	12 Volt, DMS and Illuminated Remote Run Button	
24Z958	24 Volt, DMS and Illuminated Remote Run Button	
26A848	24 Volt, DMS and Illuminated Remote Run Button, 1000 psi	
26C494	12 Volt, DMS with follower	
26C495	12 Volt Standard 1000 psi	
25V619	12 Volt Telematic Outputs and Illuminated Remote Run Button, 2000 psi	
2008338	12 Volt Telematic Outputs and Illuminated Remote Run Button, 1000 psi	
Pump Spares		
25C987	Electric Grease Jockey Pump Element	
25C965	Vent Valve assembly, 12 VDC	
25C966	Vent Valve assembly, 24 VDC	
129801	Vent Valve power cable	
Injectors and Manifolds		
24Z682	#0, Grease Injector Meter, Slack Adj, Zero Spacers	
24Z683	#1, Grease Injector Meter, S-Cams, 5th Wheel Pivot, One Spacer	
24Z684	#2, Grease Injector Meter, Tie Rod, Drag Links, Two Spacers	
24Z685	#3, Grease Injector Meter, King Pins, Spring Shackles, Three Spacers	
24Z686	#4, Grease Injector Meter, Spotter Truck 5th Wheel, Four Spacers	

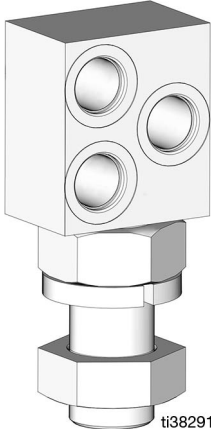
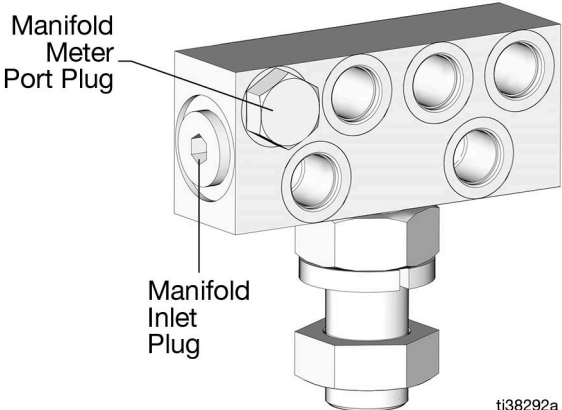
Part No.	Description	Illustration
24Z681	#8, Grease Injector Meter, 5th Wheel Plate, Round on the Hex, Four Spacers	
557898	Injector Spacers	
25C988	Bare Manifold with Stem, Nut and Washer, Six port (bare Block)	
25C989	Bare Manifold with Stem, Nut and Washer, 12 port (Bare Block)	
24Z808	Manifold Meter Port Plug with O-ring	
129752	Manifold Inlet Plugs	

Technical Specifications

Grease Jockey Automatic Lubrication System		
	US	Metric
Maximum fluid working pressure	2000 psi	13.79 MPa, 137.9 bar
	1000 psi	6.89 MPa, 68.9 bar
Fluid	Grease NLGI 000 - #2	
Grease Jockey Pump		
Pump Output Pressure	2000 psi	13.79 MPa, 137.9 bar
Power		
12 VDC	9 - 16 VDC; 7 A current, 84 W, inrush/locked rotor 12 A	
24 VDC	18 - 32 VDC; 4A current, 96 W, inrush/locked rotor 6 A	
Vent Valve		
Vent Valve Type	Normally open (vents pressure back to reservoir during pump OFF/rest time)	
Power		
12 VDC	1.6 A current, 19 W	
24 VDC	0.8 A current, 19 W	
Pump Elements	1	
Pump Output	0.5 in. ³ / minute per outlet	8.2 cm ³ / minute per outlet
Pump Outlet	9/16-18, -6 SAE ORB	
Reservoir Size	2 Liters	
IP Rating	IP69K	
Weight (Dry - includes power cord and plug)	13.3 lbs	6.03 kg
Wetted Parts	nylon 6/6 (PA), amorphous polyamide, zinc plated steel, carbon steel, alloy steel, stainless steel, nitrile rubber (buna-N), bronze, nickel plated alnico, chemically lubricated acetal, aluminum, PTFE	
Sound Data	<60 dB	
Main Fluid Line Hose		
Maximum Hose Pressure	2250 psi	15.5 MPa, 155.1 bar
Ambient and Fluid Temperature	-56°F to 302°F	-49°C to 150°C
Minimum Bend Radius	4 in.	10.1 cm
Hose Fitting	37° female JIC-6 swivel (9/16-18 UNF Threaded)	
Hose ID	5/16 in.	
Wetted Parts	AQP elastomer tube, polyester inner braid, single wire braid reinforcement, blue polyester braid cover	
Weight - hose alone without fittings	0.23 lbs /ft	0.27 kg /m

Grease Jockey Automatic Lubrication System		
	US	Metric
Injectors		
Maximum Operating Pressure	2000 psi	13.79 MPa, 137.9bar
Minimum Operating Pressure	450 psi	3.2 MPa, 31.5 bar
Reset Pressure	250 psi	1.72 MPa, 17.24 bar
Output Volume per Cycle		
Size 0 injector	0.002 cu. in.	0.033 cm ³
Size 1 injector	0.005 cu. in.	0.082 cm ³
Size 2 injector	0.009 cu. in.	0.15 cm ³
Size 3 injector	0.012 cu. in.	0.19 cm ³
Size 4 injector	0.015 cu. in.	0.25 cm ³
Size 8 injector	0.026 cu. in.	0.43 cm ³
Wetted Parts	aluminum, nitrile rubber (buna-N0, brass, carbon steel, alloy steel)	
Feed Line Tubing		
Outside Diameter	3/16 inch	
Maximum Operating Pressure	800 psi	5.5 MPa, 55 bar

California Proposition 65

 **WARNING:** This product can expose you to chemicals known to the State of California to cause cancer and birth defects or other reproductive harm. For more information, go to www.P65warnings.ca.gov.

Graco ILE On-Road Electric Grease Jockey (EGJ) Warranty

Graco warrants all equipment referenced in this document which is manufactured by Graco and bearing its name to be free from defects in material and workmanship on the date of sale to the original purchaser for use. With the exception of any special, extended, or limited warranty published by Graco, Graco will, for a period of sixty (60) months from the date of sale, repair or replace pump, pump element, injector meters and modules ("EGJ Parts") that are part of an ILE On-Road Electric Grease Jockey system, and only such EGJ Parts that are determined by Graco to be defective. The sixty-month warranty applies only to on-road trucking applications (e.g., on-road freight hauling) in low corrosion environments. For the avoidance of doubt, the sixty-month warranty does not apply to (1.) off-road applications (e.g., mining or agricultural operations) (2.) high corrosion environment applications (e.g., snow/ice removal operations), or (3.) electrical cables, tubes, hoses, and fittings. Applications other than on-road trucking are covered for a period of twelve (12) months from the date of sale. Further, this warranty applies only when the equipment is installed, operated and maintained in accordance with Graco's written recommendations.

Electric Grease Jockey Sixty (60) Month Warranty Summary		
Component Description	Application	Warranty Period
Pump, Pump Element, Injector Meters, Meter Modules	On-Road and Over-The-Road Trucking	60 months
Pump, Pump Element, Injector Meters, Meter Modules	Off-Road Trucking; Mixed-Use Trucking; Corrosive Environment	12 months
Electric Cables, hoses, tubes, and fittings	EGJ Applications listed above	12 months

This warranty does not cover, and Graco shall not be liable for general wear and tear, or any malfunction, damage or wear caused by faulty installation, misapplication, abrasion, corrosion, inadequate or improper maintenance, negligence, accident, tampering, or substitution of non-Graco component parts. Nor shall Graco be liable for malfunction, damage or wear caused by the incompatibility of Graco equipment with structures, accessories, equipment or materials not supplied by Graco, or the improper design, manufacture, installation, operation or maintenance of structures, accessories, equipment or materials not supplied by Graco.

This warranty is conditioned upon the prepaid return of the equipment claimed to be defective to an authorized Graco distributor for verification of the claimed defect. If the claimed defect is verified, Graco will repair or replace free of charge any defective parts. The equipment will be returned to the original purchaser transportation prepaid. If inspection of the equipment does not disclose any defect in material or workmanship, repairs will be made at a reasonable charge, which charges may include the costs of parts, labor, and transportation.

THIS WARRANTY IS EXCLUSIVE, AND IS IN LIEU OF ANY OTHER WARRANTIES, EXPRESS OR IMPLIED, INCLUDING BUT NOT LIMITED TO WARRANTY OF MERCHANTABILITY OR WARRANTY OF FITNESS FOR A PARTICULAR PURPOSE.

Graco's sole obligation and buyer's sole remedy for any breach of warranty shall be as set forth above. The buyer agrees that no other remedy (including, but not limited to, incidental or consequential damages for lost profits, lost sales, injury to person or property, or any other incidental or consequential loss) shall be available. Any action for breach of warranty must be brought within six months of the end of the applicable warranty period.

GRACO MAKES NO WARRANTY, AND DISCLAIMS ALL IMPLIED WARRANTIES OF MERCHANTABILITY AND FITNESS FOR A PARTICULAR PURPOSE, IN CONNECTION WITH ACCESSORIES, EQUIPMENT, MATERIALS OR COMPONENTS SOLD BUT NOT MANUFACTURED BY GRACO.

These items sold, but not manufactured by Graco (such as electric motors, switches, hose, etc.), are subject to the warranty, if any, of their manufacturer. Graco will provide purchaser with reasonable assistance in making any claim for breach of these warranties. In no event will Graco be liable for indirect, incidental, special or consequential damages resulting from Graco supplying equipment hereunder, or the furnishing, performance, or use of any products or other goods sold hereto, whether due to a breach of contract, breach of warranty, the negligence of Graco, or otherwise.

Graco Information

For the latest information about Graco products, visit www.graco.com.

For patent information, see www.graco.com/patents.

TO PLACE AN ORDER, contact your Graco distributor or call to identify the nearest distributor.

Phone: 612-623-6928 or Toll Free: 1-800-533-9655, Fax: 612-378-3590

All written and visual data contained in this document reflects the latest product information available at the time of publication. Graco reserves the right to make changes at any time without notice.

Original instructions. This manual contains English. MM 3A5082

Graco Headquarters: Minneapolis

International Offices: Belgium, China, Japan, Korea

GRACO INC. AND SUBSIDIARIES • P.O. BOX 1441 • MINNEAPOLIS MN 55440-1441 • USA
Copyright 2017 Graco Inc. All Graco manufacturing locations are registered to ISO 9001.

www.graco.com
Revision R, October 2024