

Air-Driven Agitators

3A4792R

EN

Radial piston, pneumatic motor driven agitators for maintaining suspension and even mixing in industrial paints and coatings. For professional use only.

See page 3 for model information, including maximum working pressure and approvals.

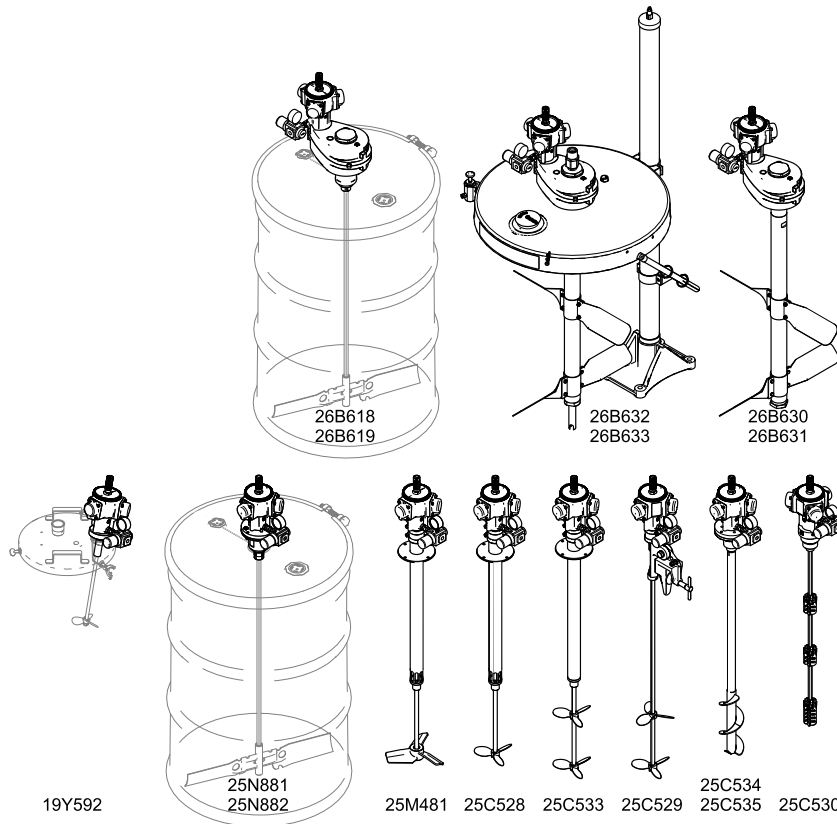

Important Safety Instructions

Read all warnings and instructions in this manual before using the equipment. Be familiar with the proper control and usage of the equipment. Save these instructions.





Contents

Contents	2	Parts	26
Related Manuals	2	Model 25C528	26
Models	3	Model 25C533	27
Safety Symbols	5	Model 25M481	28
Warnings	6	Model 25C529	29
Installation	9	Models 25C534, 25C535	30
Air Regulator and Mufflers	9	Model 25C530	31
Agitator	11	Models 25N881, 25N882	32
Grounding	16	Model 19Y592	33
Air Line Accessories	17	Models 26B630, 26B631, 238250	34
Air Requirements	18	Models 26B618, 26B619	36
Operation	19	Models 26B632, 26B633	38
Agitator Operation	19	Accessories	40
Back Gear Operation	19	Sensor Kit 25C373	40
Finding the Proper Agitator Speed	20	DataTrak Kit 25P394	40
Pressure Relief Procedure	20	Dimensions	41
Maintenance	21	Mounting Hole Layouts	44
Greasing the Air Motor	21	Air Consumption	45
Air Motor Muffler	21	Technical Specifications	46
Agitator Blades	21	Models 25C528, 25C533, 25M481	46
Cleaning the Shaft	22	Model 25C529	46
Cleaning an Agitator with a Siphon Kit	22	Models 25C534, 25C535	47
Servicing the Gear Reducer	22	Model 25C530	47
Service	24	Models 25N881, 25N882	47
Removing the Air Motor	24	Model 19Y592	48
Aligning the Outlet Housing — 25C534, 25C535 Only	25	Model 25C765	48
Inspecting the Shaft and Agitator Blades — Model 25C530 Only	25	Models 26B618, 26B619, 26B630, 26B631, 26B632, 26B633, 25T862	49
		California Proposition 65	49
		Graco Standard Warranty	50





Related Manuals

English Manual Number	Description
306287	Elevators and Pump Supports
308466	Stainless Steel, Passivated Drum Covers
3A5050	Motor Repair Manual
306670	Air Driven, 5 Gal. (19 Liter) Size Agitators

Models







Part	Maximum Working Pressure psi (kPa, bar)	Description	Recommended Agitator Rotation	Approvals	
25C528	70 psi (500 kPa, 5bar)	Stainless Steel Direct Drive, 30/55 Gallon, One SS 5.5" Propeller	Clockwise	  II 1/2 G Ex h IIB T4 Ga/Gb CML 24ATEX6027X IECEx CML 24.0020X 0°C ≤ Tamb ≤ 50°C	
25C533		Carbon Steel Direct Drive, 30/55 Gallon, Two Alum 5.5" Propellers	Clockwise		
25M481		Stainless Steel Direct Drive, 30/55 Gallon, One SS 8" Impeller	Clockwise		
25C534		Stainless Steel Direct Drive, Helix, Bung Mount	Clockwise		
25C535		Carbon Steel Direct Drive, Helix, Bung Mount	Clockwise		
25C530		Stainless Steel Direct Drive, 55 Gallon, Bung Mount, Expanding Blade	Counter Clockwise		
25N881		In-Drum, 1.5" Bung Mount	Clockwise	 II 2 G Ex h IIB T4 Gb	
25N882		In-Drum, 2" Bung Mount	Clockwise		
25C529			Carbon Steel Direct Drive, 55 Gallon, Side Mount, Two Aluminum 5.5" Propellers	Clockwise	

Models

Part	Maximum Working Pressure psi (kPa, bar)	Description	Recommended Agitator Rotation	Approvals
25C765	70 psi (500 kPa, 5 bar)	Kit, Motor with Air Regulator (to replace drive motor on existing agitator part numbers (206758, 207953, 222698, 206760, 203711, 204995, 206219) Note: Not to be used in corrosive environments. For shaft loading restrictions, see Model 25C765, Model 25C765 , page 48.	Clockwise	  II 2 G Ex h IIB T4 Gb
19Y592		Kit, Motor and parts (to retrofit an existing 5–10 gallon pail agitator part numbers 226086, 224572, 224571, 243340)	Clockwise	
26B618		6:1 Gear Reduction, In-Drum, Heavy Duty, 2" Bung Mount	Clockwise	 2575  II 1/2 G Ex h IIB T4 Ga/Gb CML 24ATEX6023X +1°C ≤ Ta ≤ +40°C
26B619		6:1 Gear Reduction, In-Drum, Heavy Duty, 1.5" Bung Mount	Clockwise	
26B630		6:1 Gear Reduction, Heavy Duty	Clockwise	
26B631		6:1 Gear Reduction, Heavy Duty, with Siphon Kit	Clockwise	
26B632		6:1 Gear Reduction, Heavy Duty, with Elevator and Drum Cover	Clockwise	
26B633		6:1 Gear Reduction, Heavy Duty, with Elevator, Drum Cover, and Siphon Kit	Clockwise	
25T862		Kit, Retrofit, motor and parts to retrofit back geared agitators	Clockwise	-----

Safety Symbols

Symbol	Meaning
	Burn Hazard
	Crush Hazard
	Equipment Misuse Hazard
	Fire and Explosion Hazard
	Entanglement Hazard
	Moving Parts Hazard
	Pressurized Equipment Hazard
	Splatter Hazard

Symbol	Meaning
	Splash Hazard
	Toxic Fluid or Fumes Hazard
	Ground Equipment
	Follow Pressure Relief Procedure
	Ventilate Work Area
	Wear Personal Protective Equipment
	Eliminate Ignition Sources



















Safety Alert Symbol

This symbol indicates: Attention! Become Alert! Look for this symbol throughout the manual to indicate important safety messages.

Warnings

The following warnings apply throughout this manual. Read, understand, and follow the warnings before using this equipment. Failure to follow these warnings can result in serious injury.

 <h2 style="margin: 0;">WARNING</h2>	
   	<p>FIRE AND EXPLOSION HAZARD</p> <p>Flammable fumes, such as solvent and paint fumes, in work area can ignite or explode. Paint or solvent flowing through the equipment can cause static sparking. To help prevent fire and explosion:</p> <ul style="list-style-type: none"> • Use equipment only in well-ventilated area. • Eliminate all ignition sources, such as pilot lights, cigarettes, portable electric lamps, and plastic drop cloths (potential static sparking). • Ground all equipment in the work area. See Grounding instructions. • Never spray or flush solvent at high pressure. • Keep work area free of debris, including solvent, rags and gasoline. • Do not plug or unplug power cords, or turn power or light switches on or off when flammable fumes are present. • Use only grounded hoses. • Hold gun firmly to side of grounded pail when triggering into pail. Do not use pail liners unless they are anti-static or conductive. • Stop operation immediately if static sparking occurs or you feel a shock. Do not use equipment until you identify and correct the problem. • Keep a working fire extinguisher in the work area.
 	<p>MOVING PARTS HAZARD</p> <p>Moving parts can pinch, cut or amputate fingers and other body parts.</p> <ul style="list-style-type: none"> • Keep clear of moving parts. • Do not operate equipment with protective guards or covers removed. • Equipment can start without warning. Before checking, moving, or servicing equipment, follow the Pressure Relief Procedure and disconnect all power sources.
  	<p>PRESSURIZED EQUIPMENT HAZARD</p> <p>Fluid from the equipment, leaks, or ruptured components can splash in the eyes or on skin and cause serious injury.</p> <ul style="list-style-type: none"> • Follow the Pressure Relief Procedure when you stop spraying/dispensing and before cleaning, checking, or servicing equipment. • Tighten all fluid connections before operating the equipment. • Check hoses, tubes, and couplings daily. Replace worn or damaged parts immediately.

 <h1 style="margin: 0;">WARNING</h1>	
 	<p>EQUIPMENT MISUSE HAZARD Misuse can cause death or serious injury.</p> <ul style="list-style-type: none"> • Do not operate the unit when fatigued or under the influence of drugs or alcohol. • Do not exceed the maximum working pressure or temperature rating of the lowest rated system component. See Technical Specifications in all equipment manuals. • Use fluids and solvents that are compatible with equipment wetted parts. See Technical Specifications in all equipment manuals. Read fluid and solvent manufacturer’s warnings. For complete information about your material, request Safety Data Sheets (SDSs) from distributor or retailer. • Do not leave the work area while equipment is energized or under pressure. • Turn off all equipment and follow the Pressure Relief Procedure when equipment is not in use. • Check equipment daily. Repair or replace worn or damaged parts immediately with genuine manufacturer’s replacement parts only. • Do not alter or modify equipment. Alterations or modifications may void agency approvals and create safety hazards. • Make sure all equipment is rated and approved for the environment in which you are using it. • Use equipment only for its intended purpose. Call your distributor for information. • Route hoses and cables away from traffic areas, sharp edges, moving parts, and hot surfaces. • Do not kink or over bend hoses or use hoses to pull equipment. • Keep children and animals away from work area. • Comply with all applicable safety regulations.
 	<p>TOXIC FLUID OR FUMES HAZARD Toxic fluids or fumes can cause serious injury or death if splashed in the eyes or on skin, inhaled, or swallowed.</p> <ul style="list-style-type: none"> • Read Safety Data Sheets (SDSs) to know the specific hazards of the fluids you are using. • Store hazardous fluid in approved containers, and dispose of it according to applicable guidelines.
	<p>BURN HAZARD Equipment surfaces and fluid that is heated can become very hot during operation. To avoid severe burns:</p> <ul style="list-style-type: none"> • Do not touch hot fluid or equipment.



WARNING



PERSONAL PROTECTIVE EQUIPMENT

Wear appropriate protective equipment when in the work area to help prevent serious injury, including eye injury, hearing loss, inhalation of toxic fumes, and burns. Protective equipment includes but is not limited to:

- Protective eye wear, and hearing protection.
- Respirators, protective clothing, and gloves as recommended by the fluid and solvent manufacturer.





SPECIFIC CONDITIONS OF USE

Equipment must comply with the following conditions to avoid a hazardous condition which can cause

- Electrostatic charging hazard. Clean surfaces with a damp cloth and read instructions for additional techniques to mitigate risk of electrostatic discharge
- The Ambient Temperature Range of each agitator depends on the air motor included in the assembly. Refer to **Models**, page 3 and **Technical Specifications**, page 46 in Instruction manual for additional information.



Installation

				
<p>To reduce the risk of fire and explosion, always maintain a minimum of 1 in. (25.4 mm) clearance between the rotating agitator parts and the container to prevent sparks from contact.</p>				

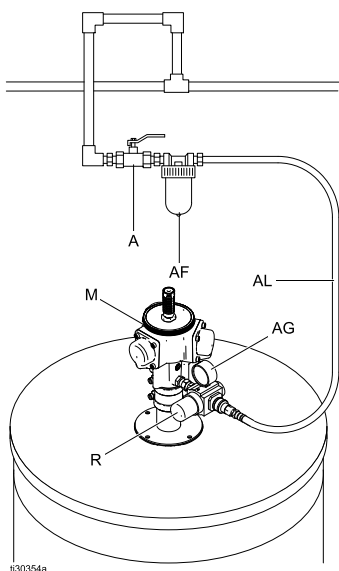

FIG. 1: Typical Installation

Reference	Description
A	Bleed-type Master Air Shutoff Valve
AF	Air Line Filter
M	Motor
AL	Supply Line, Air-In
AG	Air Pressure Gauge
R	Regulator

NOTE: Throughout the manual, reference numbers and letters in parentheses refer to callouts in figures and the parts drawings.

See **Air Line Accessories**, page 17 for parts not included in your system.

Air Regulator and Mufflers

The air motor is capable of operating in a clockwise or counterclockwise direction, depending on where the air regulator is mounted.

- When the air regulator is installed in one of the two lower ports on the motor, a clockwise rotation results, as viewed from the top of the motor.
- When installed on either side in one of the two upper ports, a counterclockwise rotation results.
- The port opposite the regulator must be plugged for the motor to operate.

The air regulator, mufflers, air gauge, nipple connector, and swivel connector are not factory installed. Follow the directions below to install these items:

1. Screw the swivel connector (F) into the desired port (upper or lower) in the motor (M).
2. Screw the nipple connector (G) into the air regulator (H) outlet. Note arrow directions on the regulator.
3. Attach the air regulator by screwing it into the swivel connector.
4. Install a plug (E) in the port opposite the regulator (this is necessary for motor operation).
5. Attach the air gauge (J) by screwing it into the hole in the top of the air regulator.
6. Install a plug (E) in the regulator in the port opposite the air gauge.
7. Screw one muffler (D) into the top of the motor.
8. Screw the second muffler into the open port on the far side of the motor from the regulator.
9. Install the third muffler in the open port above or below the regulator. An additional fitting may be needed (not provided) to space the regulator farther away from the motor.

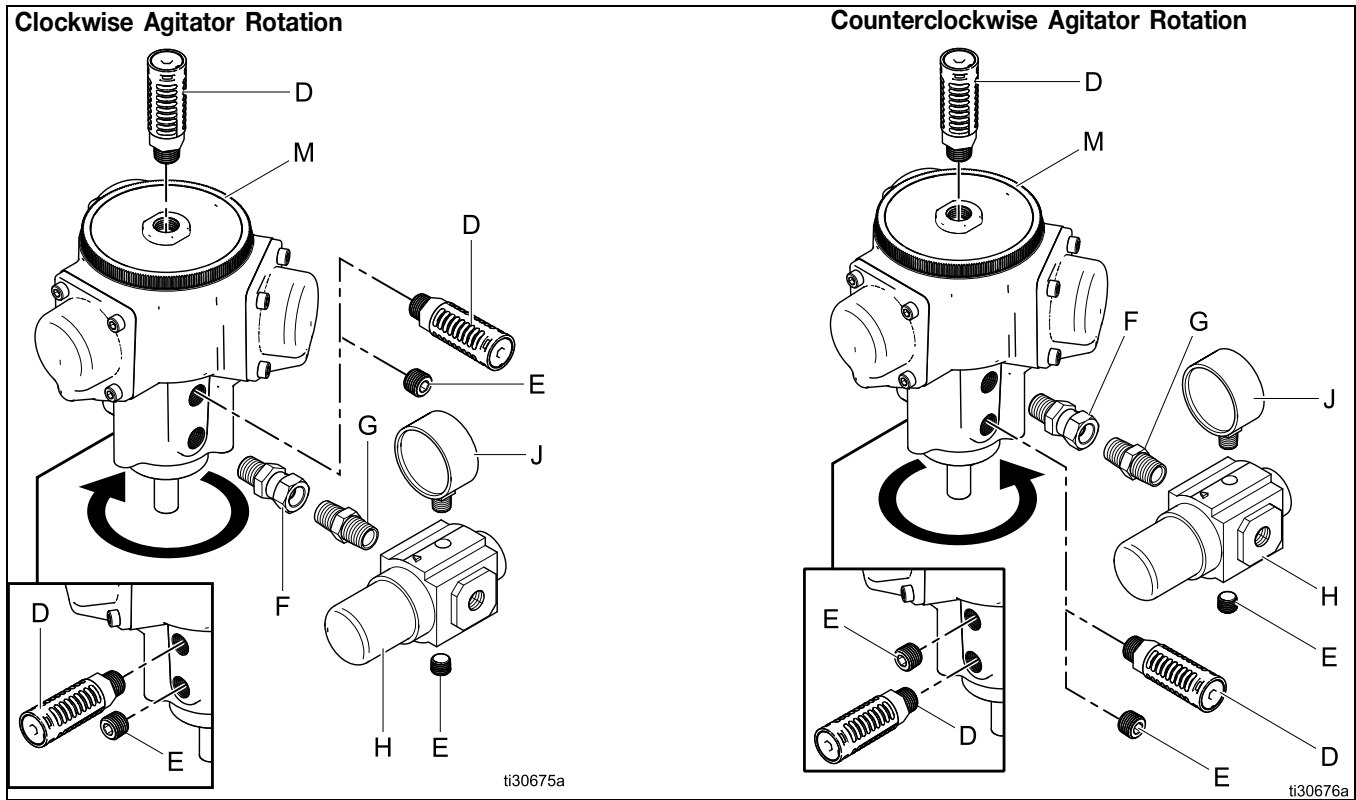

Note: Use of the third muffler is not necessary, but is beneficial for increased air circulation in humid conditions. If a third muffler is not used, the hole must be plugged (E).



Key:

- D Mufflers
- E Plugs
- F Swivel connector
- G Nipple connector
- H Air regulator
- J Air gauge
- M Air motor

Agitator

				
<p>To reduce the risk of fire and explosion, always maintain a minimum of 1 in. (25.4 mm) clearance between the rotating agitator parts and the container to prevent sparks from contact.</p>				

Models 25C528, 25C533, and 25M481

1. Mark and drill holes in the cover to mount the agitator. For dimensions, see **Mounting Hole Layouts**, page 44.
2. Install the agitator in the cover of the fluid supply tank with the gasket (29) in place. See:
 - **Model 25C528**, page 26
 - **Model 25C533**, page 27
 - **Model 25M481**, page 28
3. Position the air motor so the air line easily attaches to the air regulator inlet without obstructing any other system components.
4. Bolt in place (mounting bolts not included).

Model 25C529

Mount the agitator on the edge of the drum or tank and securely tighten the clamp screw (6). Squeeze the end of the retainer (17) to set in place. See **Model 25C529**, page 29.

To adjust the angle of the agitator in the drum, loosen the bracket screw (4), and position the air motor so the air line easily attaches to the air regulator inlet without obstructing any other system components.

Models 25C534 and 25C535

Install the agitator in the container cover by screwing the helix (5) through the drum bung hole and screwing the agitator housing (3) into the bung hole. Torque the socket head screw (2) to 150–170 in-lbs (17–19 N•m). Torque the hex head cap screw (14) to 80–100 in-lbs (9–11 N•m). See **Models 25C534, 25C535**, page 30.

Position the air motor so the air line easily attaches to the air regulator inlet without obstructing any other system components.

Model 25C530

To install the agitator in the container cover, lower the shaft (2) with folding blade assemblies (5, 6) through the drum bung hole, then screw the bung adapter (4) into the bung hole. See **Model 25C530**, page 31.

Position the air motor so the air line easily attaches to the air regulator inlet without obstructing any other system components.

Due to variability in drum heights, the lowest set of blades may contact the bottom of the drum. If the bung adapter (4) does not fully seat, or if resistance is felt when installing the agitator, move the blades up the shaft.

To move the blades, loosen the setscrews (SS) in the coupler and slide the assembly up or down to the desired position. The setscrew must always remain on the top, with the blades hanging down, so the blades are able to pass into and out of the bung hole.

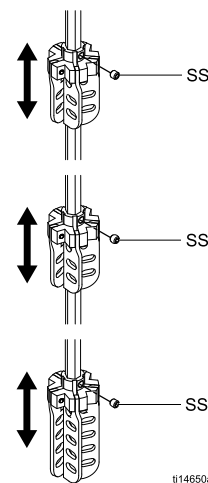



FIG. 2: Adjustable Blade Assemblies

				
<p>To reduce the risk of fire and explosion, when using a modified drum, check that there is no interference between the base of the drum and the shaft of the agitator to avoid sparks from contact.</p>				

NOTICE
<p>Keep the agitator tightly mounted to the drum bung to prevent damage to the threads from vibration.</p>

Angled Adapter 16H294 — Model 25C530 only

If the agitator is used on a drum with an off-center bung and the blades contact the side of the drum, the angled adapter 16H294 must be used.

1. Thread the locking ring (28) onto the angled adapter (27) by hand, as far as it will go.
2. Thread the angled adapter into the bung until it bottoms out, then back it out until the widest portion of the adapter top is pointing just to the left of drum center.

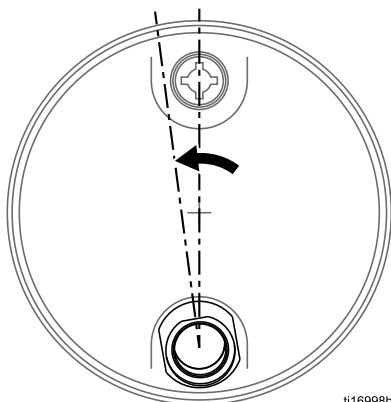

Fig. 3: Angled Adapter Just Left of Center

3. Turn down the locking ring until it contacts the drum. Use an appropriately sized pipe wrench or adjustable wrench to tighten the adapter until the widest portion of the adapter top is in line with the drum center.

Back Geared Agitator Models 26B618, 26B619, 26B630, 26B631, 26B632, and 26B633

See the following sections for part information:

- **Models 26B618, 26B619**, page 36
- **Models 26B630, 26B631, 238250**, page 34
- **Models 26B632, 26B633**, page 38

Assembling and Positioning the Agitator

With an Elevator

Mount the drum cover as described in manual 306287. The elevator must be in the down position when you do any work on the elevator, agitator, or drum cover assembly. Do not go under the elevator when it is

raised. Proceed to step 1 in the **Installation With or Without an Elevator**, page 12.

Without an Elevator

If your system does not have an elevator, install the Handles Kit 237524 to facilitate handling the drum cover and agitator. Two people are needed to safely lift and move the drum cover and agitator. Place two standard 55 U.S. gallon (45 Imperial gallon) barrels 14 in. (36 cm) apart. Center the drum cover on the barrels with the Graco logo centered and facing you, as shown in the following figure. Proceed to step 1 in the **Installation With or Without an Elevator**, page 12.

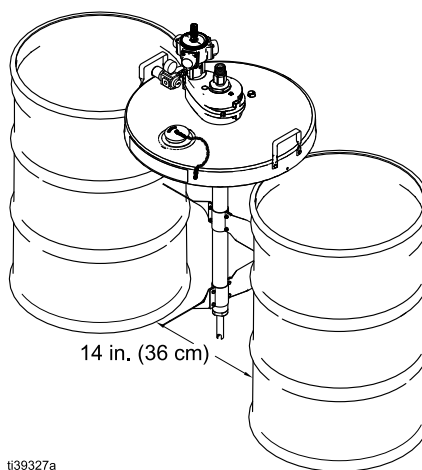

Fig. 4: Assembling and Positioning Agitator Without an Elevator

Installation With or Without an Elevator

1. Slide the agitator shaft through the large hole in the center of the drum cover.
2. Rotate the agitator so that the air motor is to the left of the shaft, as shown in Fig. 4. In this position, the three tapped holes in the bottom of the agitator align with the three through holes in the drum cover.
3. Thread the three hex head screws (25) up through the drum cover and into the agitator. Torque the screws to 75 in-lb (8.4 N•m).
4. Assemble one pair of agitator blades (28) so that the four through holes in the blade halves are lined up. For blade orientation, see **Models 26B630, 26B631, 238250**, page 34 and **Models 26B632, 26B633**, page 38.
5. Push four cap screws (31) through the four holes in the blades, and start the lock nuts (32) onto the cap screws.

6. Slide the loose blade assembly up the shaft, and position it approximately 13 in. (33 cm) from the bottom of the shaft.
7. Tighten the four lock nuts (32) evenly to draw the blades together until they are tight on the shaft. Torque the locknut to 50–55 in-lb (5.6–6.2 N•m). A gap will remain between the blade halves.
8. Repeat steps 4 and 5 with the second pair of agitator blades.
9. Position the second blade assembly near the bottom end of the shaft, but not on the bottom plug (20).
10. Rotate the lower blade assembly so that it is oriented 90 degrees relative to the upper blade assembly. Torque the lock nuts (32) to 50–55 in-lb (5.6–6.2 N•m). A gap will remain between the blade halves.

Installation for In-drum Heavy Duty Back Geared Agitator

1. Determine which size adapter nut (20) is needed. The adapter nuts in the kit are double-sided so that each adapter nut fits two agitator shaft sizes. Select the size you need by placing the adapters onto the built in agitator shaft in the drum. Use the smallest size that fits. There should only be a small amount of slop between the adapter nut and the shaft.
2. Thread the adapter into the gearbox output shaft (6) with the side you are going to use pointed down. Tighten it using the wrench flats.
3. Place the threaded bung housing adapter (34) onto the gearbox and align the bolt holes.
4. Thread the three bolts (28) into the gearbox and torque to 10 ft-lb (13.5 N•m).
5. Align the adapter nut to engage the built-in shaft in the 55-gallon drum.
6. Slowly screw the unit onto the threads on the center bung fitting of the 55-gallon drum. Hand tighten to secure the unit. The unit should not easily unthread from the drum.

Siphon Kit Installation

Use this procedure to install Siphon Kit 238250. See **Models 26B630, 26B631, 238250**, page 34.

1. Remove the top plug (5) and the bottom plug (20).
2. Replace the bottom plug (20) with the plain bearing (50d), and tighten the bearing with a wrench.
3. Work the PTFE o-ring (50e) onto the siphon tube retainer (50b). Leave the retaining nut (50c) on the siphon tube retainer, but do not tighten. Tighten the siphon tube retainer into the top of the agitator housing with a wrench.
4. Slide the siphon tube (50a) down through the retaining nut (50c), siphon tube retainer (50b), and agitator shaft (6) until the siphon tube touches the bottom of the drum. Raise the siphon tube approximately ¼ in. (approximately 6 mm) so that it does not touch the bottom of the drum. Hold the siphon tube at this height with one hand and tighten the retaining nut with the other hand. (Hand-tight is enough to hold the siphon tube in place.)

NOTICE

Barrel Heights Vary

Loosen the retaining nut on the siphon tube retainer before you raise the drum cover. If you do not loosen the retaining nut, the siphon tube may make contact with the bottom of the barrel when you lower the drum cover onto a new barrel, which could damage the siphon tube or the barrel.

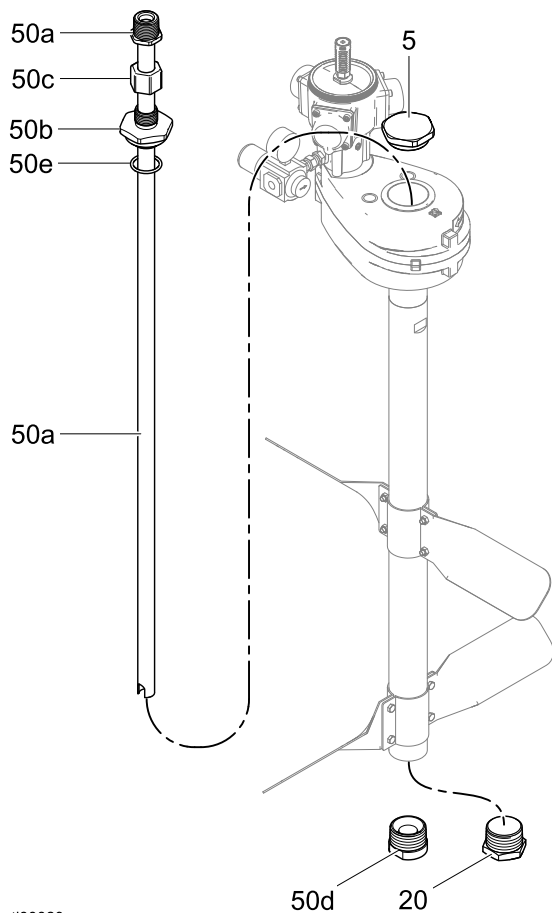

ti39329a

Fig. 5: Siphon Kit, Model 238250

Return Tube Kit 238884 (Accessory)

Return Tube Kit 238884 is available as an accessory. The kit must be ordered separately. Refer to the sheet packed with the kit for installation instructions.

Retrofit Kit 25T862

Retrofit Kit 25T862 is a drop-in replacement that provides a 6:1 gear reduction for the gearbox and air motor. Use Kit 25T862 on back-geared agitator models that have a 24:1 gear reduction, in operation with high-viscosity materials. These models are 231413, 231414, 238157, 240209, 24C522, and 24C293.

Use the installation procedure that matches your configuration:

- Installation in 26B618 or 26B619, page 14
- Installation in 26B630 or 26B631, page 15
- Installation in 26B632 or 26B633, page 15

NOTE: Use Retrofit Kit 25T862 only with the 25C765 radial piston air motor included in the kit. The user risks damage to the rotary vane air motor (part number 101140) if used with the 6:1 gearbox in this kit.

<p>To reduce the risk of fire and explosion, when using a modified drum, check that there is no interference between the base of the drum and the shaft of the agitator to avoid sparks from contact.</p>				

NOTICE
<p>Keep the agitator tightly mounted to the drum bung to prevent damage to the threads from vibration.</p>

Installation in 26B618 or 26B619

For In-Drum Heavy Duty Back Geared Agitator

For parts information, see **Models 26B618, 26B619**, page 36.

1. Follow the **Pressure Relief Procedure**, page 20.
2. Unscrew the gearbox unit from the center bung fitting of the 55-gallon drum.
3. Disengage and remove the unit from the built-in shaft in the 55-gallon drum.
4. Unscrew the three bolts (28) in the gearbox.
5. Remove the threaded bung housing adapter (34) from the gearbox.
6. Remove the adapter (20) by unscrewing it from the gearbox output shaft (6).
7. Replace the gearbox and the air motor unit with Retrofit Kit 25T862. Reinstall the agitator assembly by repeating installation steps 2–6 in Installation for In-drum Heavy Duty Back Geared Agitator, page 13.

Installation in 26B630 or 26B631

For Heavy Duty Back Geared Agitator without an Elevator

For parts information, see **Models 26B630, 26B631, 238250**, page 34.

1. Follow the **Pressure Relief Procedure**, page 20.
2. Remove and position the drum cover and agitator by following the instructions in **Assembling and Positioning the Agitator**, page 12 and **Without an Elevator**, page 12.
3. Carefully separate the gearbox output shaft (6a) from the agitator shaft (6b) using the wrench flats on both shaft sections.
4. Remove the agitator assembly from the drum cover by loosening the screws (25) that attach the gearbox to the drum cover.
5. Replace the gearbox and the air motor unit with Retrofit Kit 25T862.
6. Reinstall the agitator assembly with the motor to the left and align the gearbox threads with the mounting holes in the drum cover. Thread the three hex head screws (25) up through the drum cover and into the agitator. Torque the screws to 75 in-lb (8.4 N•m).
7. Reconnect the agitator shaft (6b) into the gearbox output shaft (6a). Tighten down using wrench flats.
8. Replace and position the drum cover and agitator back onto the drum of material.
5. Carefully separate the gearbox output shaft (6a) from the agitator shaft (6b) using the wrench flats on both shaft sections.
6. Remove the agitator assembly from the drum cover by loosening the screws (25) that attach the gearbox to the drum cover.
7. Replace the gearbox and the air motor unit with Retrofit Kit 25T862.
8. Reinstall the agitator assembly with the motor to the left and align the gearbox threads with the mounting holes in the drum cover. Thread the three hex head screws (25) up through the drum cover and into the agitator. Torque the screws to 75 in-lb (8.4 N•m).
9. Reconnect the agitator shaft (6b) into the gearbox output shaft (6a). Tighten down using wrench flats.
10. Raise the drum elevator (102) to the up position. Do not go under the elevator when it is raised.
11. Place the drum back in the original position underneath the agitator.
12. Slowly lower the elevator to the down position while carefully guiding the agitator back into the drum. Make sure that there is nothing in between the drum cover and the drum as the elevator lowers, including fingers and hands.

Installation in 26B632 or 26B633

For Heavy Duty Back Geared Agitator with an Elevator

For parts information, see **Models 26B632, 26B633**, page 38.

1. Follow the **Pressure Relief Procedure**, page 20.
2. Raise the drum elevator (102) to remove the agitator assembly from the drum of material.
3. Remove the drum and place it out of the way. Do not go under the elevator when it is raised.
4. Lower the elevator to the down position. The elevator must be in the down position to perform any work on the elevator, agitator, or drum cover assembly.
1. Determine the agitator shaft size: 7/16" (11.1 mm) or 1/2" (12.4 mm) square. Determine the size of the shaft adapter (9). Select the size by placing the adapters onto the built-in agitator shaft inside the drum. Use the smallest adapter that will fit. There should only be a small amount of slip between the adapter nut and the shaft.
2. Attach the shaft adapter (9) to the flat side of the motor shaft close to the bottom of the motor. Tighten the set screw (12) securely to 8–9 ft-lbs (11–12 N•m).

NOTE: There is approximately 1/2" (12 mm) of adjustment travel of the adapter shaft on the motor shaft if needed for later adjustment.
3. Torque the socket head screw (8) to 12.5–14ft-lbs (17–19 N•m).

Models 25N881 and 25N882

For parts information, see **Models 25N881, 25N882**, page 32.

Installation

- Place the threaded housing adapter (6) onto the motor plate (7) and secure with washers (13) and screws (11). Torque to 8–9 ft-lbs (11–12 N•m).
- Align the adapter nut to engage the built-in shaft in the 55-gallon drum.
- Slowly screw the unit onto the threads on the center bung fitting of the 55-gallon drum. Secure tightly so the motor does not rotate in the bung.

Motor Replacement Kit 25C765

Motor Replacement Kit 25C765 is a drop-in replacement for rotary vane air motor (part number 101140) used on existing agitator part numbers 206758, 207953, 222698, 206760, 203711, 204995, 206219. See **Model 25C528**, page 26. Ref No. 1 lists the items included with the kit. Use the agitator manual motor replacement procedure or parts page diagram to install the new motor.

NOTICE

Do not immerse or splash the bottom of the motor in fluids. The bearing at the bottom of the motor and the shaft may corrode.

Retrofit Kit 19Y592

Motor replacement kit 19Y592 is used to retrofit existing 5–10 gallon pail agitator part numbers 226086, 224572, 224571, 243340 that use rotary vane air motor part number 101687.

- Follow the **Pressure Relief Procedure**, page 20.
- Remove the cover from the pail.
- Remove the shaft/blade from the existing agitator by loosening the set screw in the coupling. Clean the shaft/blade.
- Remove the existing motor from the pail lid.
- Insert the new motor/sleeve into the existing collar and tighten the set screw.
- Insert the shaft in the new coupling and tighten the set screw. There is room to make slight adjustments for length as needed.
- Install the cover on the pail.
- Install the air line. The agitator speed is adjusted by adjusting the air regulator pressure.

NOTE: Agitator rotation direction is determined by the supply port used on the air motor. See **Air Regulator and Mufflers**, page 9.

NOTICE

Do not immerse or splash the bottom of the motor in fluids. The bearing at the bottom of the motor and the shaft may corrode.

Grounding



The equipment must be grounded to reduce the risk of static sparking. Static sparking can cause fumes to ignite or explode. Grounding provides an escape wire for the electric current.

A ground wire and clamp are not included. For a ground wire and clamp, order part number 237569.

To ground the agitator, do the following:

- For models **25C528, 25C533, 25M481, 26B618, 26B619, 26B630, 26B631, 26B632, and 26B633**: Connect one end of the ground wire (GW) to the ground connector (GC) on the rim of the drum cover. Connect the other end of the ground wire to a true earth ground.

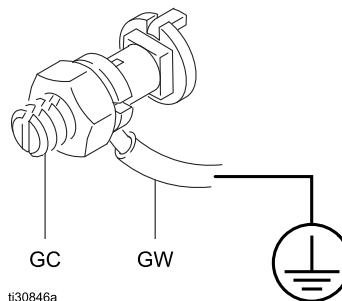

FIG. 6: Ground Connector - Models 25C528, 25C533, and 25M481

- For models **25C529, 25C530, 25C534, 25C535, 25N881, and 25N882**: Connect one end of the ground wire (GW) to the agitator ground connector (GC). Connect the other end of the ground wire to a true earth ground.

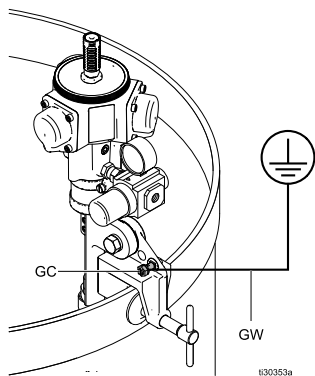

FIG. 7: Ground Connector - Model 25C529

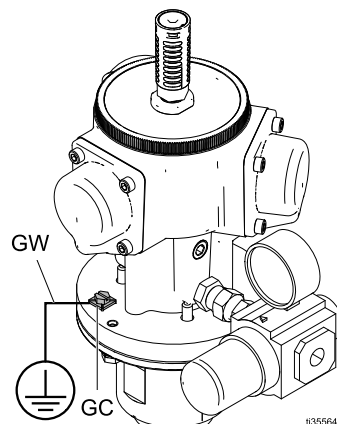

FIG. 10: Ground Connector - Models 25N881, 25N882

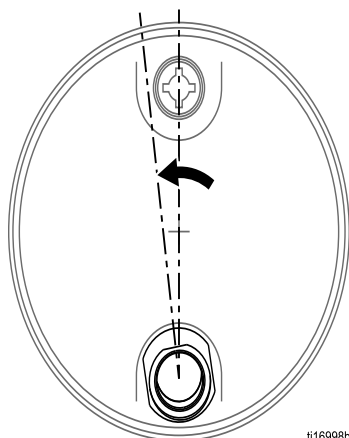

FIG. 8: Ground Connector - Model 25C530

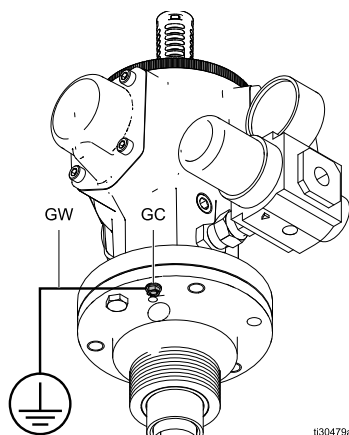

FIG. 9: Ground Connector - Models 25C534, 25C535

Air Line Accessories

Install the following accessories in the order shown below, using adapters as necessary.

Air Shutoff Valve

A bleed-type master air shutoff valve (A for mounting location) isolates the air line components for servicing. An air shutoff valve should be installed in the supply line and used to stop and start the agitator. If the valve is installed, you do not need to set the agitator speed each time it is used.

Order bleed-type air shutoff valves using the part numbers listed below:

Table 1: Bleed -Type Shutoff Valves

Part No.	Inlet/ Outlet npt	Max WPR			Material
		psi	bar	MPa	
110223	1/4 (fxf)	250	17.2	1.7	Brass
110224	3/8 (fxf)	250	17.2	1.7	Brass
110225	1/2 (fxf)	250	17.2	1.7	Brass
110226	3/4 (fxf)	250	17.2	1.7	Brass
113163	1 (fxf)	250	17.2	1.7	Brass
107142	1/2 (mxf)	250	17.2	1.7	Brass
107141	3/4 (mxf)	250	17.2	1.7	Brass

Air Line Filter

Air line filters remove harmful dirt, moisture, and oil from the compressed air supply. Order part 106148 for 3/8 npt or 106149 for 1/2 npt.

Install an air line filter (AF) to remove contaminants such as dirt, moisture, and oil from the compressed air supply. Air line filters (AF) remove harmful dirt and moisture from the compressed air supply. Order part 106148 for 3/8 npt or 106149 for 1/2 npt. See **Installation**, page 9.

Air Requirements

The air motor does not require lubricated air. See **Air Consumption**, page 45 for requirements.

Connect the supply air to the inlet side of the air regulator.

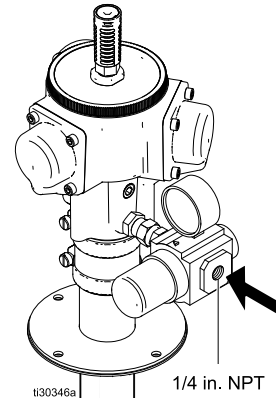

FIG. 11: Supply Air Hose Connection

Operation



Personal injury, such as splashing in the eyes, may result from pressure in the tank. Always follow the Pressure Relief Procedure, page 20 before opening the tank cover or fill port.

Personal injury or equipment damage may result from lifting/falling heavy equipment. To avoid personal injury or equipment damage:

- Do not lift the drum cover and agitator without proper assistance.
- Do not walk or stand beneath a raised elevator.

Agitator Operation

1. Start the agitator by opening the air shutoff valve (A). Regulate the speed with the air regulator knob (R).
2. Operate the agitator continuously when supplying paints or other fluids to the system.
3. Stop the agitator by closing the air shutoff valve or by reducing pressure with the air regulator knob.

NOTICE

Always maintain moderate agitator speed. Excessive agitator speed may cause vibration, foaming of fluid, and increased wear on parts. Always agitate fluid thoroughly before supplying it to the dispensing equipment. Continue agitating fluid while the dispensing equipment is being supplied.

Fill the fluid supply container to about 3 or 4 inches (75 to 100 mm) above the agitator blades to avoid excessive vibration that could cause damage to agitator.

Back Gear Operation

1. Turn the air regulator knob (R) counterclockwise to start at zero air pressure.
2. Open the air shutoff valve (A).
3. Use the air regulator knob (R) to adjust the agitator speed. Look through the inspection port and gradually increase the speed until you can see movement in the surface of the liquid. Do not increase the agitator speed so much that a vortex forms in the surface of the liquid. If the surface begins to vortex, decrease the agitator speed to prevent air entrainment.

NOTICE

Always maintain moderate agitator speed, which is approximately 50 rpm of the agitator blades. Excessive agitator speed may cause vibration, foaming of fluid, and increased wear on parts. Always agitate fluid thoroughly before supplying it to the dispensing equipment. Continue agitating fluid while the dispensing equipment is being supplied.

Finding the Proper Agitator Speed

NOTICE

To avoid damaging the equipment, do not operate the agitator at a high speed for a long period of time. Excessive agitator speed can cause foaming of fluid (making the fluid unusable), vibration, and increased wear on parts. Only agitate the fluid enough to maintain even mixing.

Agitators are used to keep solids in suspension, which assists in keeping solids from clogging the siphon tube. If solids have settled in the container, use a shaker or some other device to thoroughly agitate the fluid before installing and operating the agitator.

Below is a general procedure to find the suggested agitator speed. Consult your material supplier for specific recommendations on recommended agitation speeds.

1. Be sure ground wire is attached. See **Grounding**, page 16.
2. Fill the fluid supply container to about 3 or 4 inches (75 to 100 mm) above the agitator blade.
3. Open the air shutoff valve (A).
4. Start the agitator by gradually turning the air regulator knob (R) to increase air pressure until a vortex begins to form in the paint.
5. Reduce the speed slightly, then fill the fluid container.

When the container is full a vortex should not be seen. Material should only be moving at a fast enough speed to ensure adequate mixing.

6. Operate the agitator continuously while supplying paints or other fluids to the system.

Pressure Relief Procedure



This equipment stays pressurized until pressure is manually relieved. To help prevent serious injury from splashing fluid and moving parts, follow the Pressure Relief Procedure before cleaning, checking, or servicing the equipment.

1. Close the bleed-type air shutoff valve (A) to relieve pressure to the air regulator.
2. Disconnect the air line.

NOTICE

Keep the agitator upright. Do not lay it on its side or upside down, or liquid may flow down the shaft and into the gear reducer area.

Maintenance



Moving parts, such as an impeller blade, can cut or amputate fingers. To reduce the risk of serious injury, always shut off the agitator and disconnect the air line before checking or repairing the agitator.

Before performing any maintenance procedure, follow the **Pressure Relief Procedure**, page 20.

Greasing the Air Motor

After approximately 20 million revolutions or every three to four months (whichever comes first), grease the motor needle bearing. Recommended grease: MOBILGREASE XHP 222 SPECIAL or equivalent with minimum flash point temperature of 399.2° F (204° C).

1. Follow the **Pressure Relief Procedure**, page 20.
2. Remove the motor top cover (103).
3. Using a manual grease gun, push grease into the 21RC fitting (102) until grease is seen below the top washer (109a).

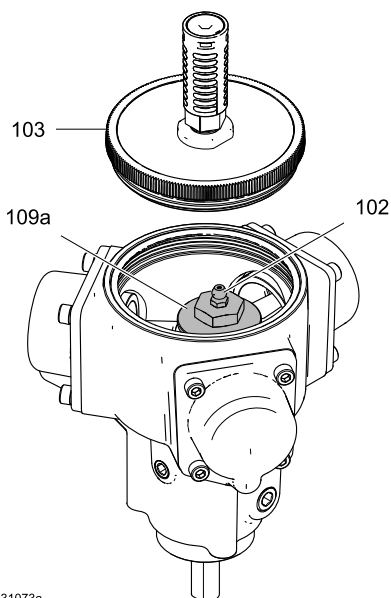

ti31073a

FIG. 12: Air Motor

Air Motor Muffler

Depending on the environment of the motor, periodically check the cleanliness of the air motor muffler. Dirty or clogged air mufflers result in decreased motor efficiency and may cause the motor to run irregularly. If the muffler is dirty or clogged, replace it with a new muffler.

Agitator Blades



Materials can become electrostatically charged when stirred or blended. To prevent fire and explosion, ground equipment and do not allow material to build up on agitator. Dried material could allow static build up and interfere with grounding.

Regularly check the agitator for dried material buildup. Clean using a rag soaked in solvent that is compatible with the spray material and the surfaces being cleaned. Additionally, extra precautions need to be taken if using lower conductive materials (<1,000 pS/m) such as:

- Avoid stirring/mixing at high speeds.
- Avoid insoluble mixtures.
- When possible, increase the material conductivity with additives.
- Use liquids with a high conductivity (>1000 pS/m)

Cleaning the Shaft

For models 25C528, 25C533, 25M481

Each week, clean any dried fluid from around the bearing (6) area of the shaft (7) and inspect the bearing for cracking or excessive wear.

For model 25C529

Each week, clean any dried fluid from around the bearing (18) and bracket (23) area of the shaft (21). Lubricate with several drops of light oil.

For models 26B618, 26B619, 26B630, 26B630, 26B631, 26B632, and 26B633

NOTICE

Keep the agitator upright. Do not lay it on its side or upside down, or liquid may flow down the shaft and into the gear reducer area.

Each week, clean any dried fluid/material on the shaft (6) near the housing (13). If any material is on the shaft (6) within ½ in. (13 mm) of the housing (13), it must be removed to prevent damage to the bearing seal (14*). If the flexible lips on the bearing seal are torn or worn such that they do not make contact all the way around the shaft, the seal must be replaced. A worn seal may allow foreign material into the bearing and cause premature failure. See **Servicing the Gear Reducer**, page 22 for instructions on getting access to the seal and for the Bearing Replacement Kit Part No.

*Included in Bearing Replacement Kit 238251.

Cleaning an Agitator with a Siphon Kit

Use the following procedure to flush and clean the siphon tube (50a) and agitator shaft (6).

1. Raise the agitator out of the drum.
2. Remove the plain bearing (50d) from the agitator shaft (6) and clean it.
3. Detach any attachments from the siphon tube. Flush the siphon tube.
4. Loosen the retaining nut (50c) and slowly lift the siphon tube (50a) out of the agitator.

5. Clean the inside and outside of the siphon tube (50a). Flush the inside of the agitator shaft (6). Clean the agitator blades (28) and the outside of the shaft.
6. Reassemble the siphon tube by doing the reverse of steps 2–4.

Servicing the Gear Reducer

You may want to have the Bearing Replacement Kit 238251 on hand before you begin this procedure. Bearing removal and installation instructions are included in the kit.

Disassembling

1. Follow the **Pressure Relief Procedure**, page 20, .
2. If your agitator has a siphon kit, perform steps 2–4 in **Cleaning an Agitator with a Siphon Kit**, page 22.

If your agitator does not have a siphon kit, proceed to step 3 below.
3. Remove the agitator from the drum of material. Separate the agitator from the agitator shaft (if applicable):
 - a. For an in-drum agitator:
 - i. Unscrew the gearbox unit from the center bung fitting of the 55-gallon drum. Disengage and remove the unit from the built-in shaft in the 55-gallon drum.
 - b. For an agitator without an elevator:
 - i. Remove and position the drum cover and agitator by following the instructions in see **Assembling and Positioning the Agitator**, page 12, see **Without an Elevator** page 12.
 - ii. Carefully separate the gearbox output shaft (6a) from the agitator shaft (6b) using the wrench flats on both shaft sections.
 - iii. Remove the agitator assembly from the drum cover by loosening the screws (25) that attach the gearbox to the drum cover.

- c. For an agitator with an elevator:
 - i. Raise the elevator (102), remove the drum and place it out of the way. Lower the elevator to the down position. The elevator must be in the down position when you do any work on the elevator, agitator, or drum cover assembly.
 - ii. Carefully separate the gearbox output shaft (6a) from the agitator shaft (6b) using the wrench flats on both shaft sections.
 - iii. Remove the agitator assembly from the drum cover by loosening the screws (25) that attach the gearbox to the drum cover.
4. Remove the two short bolts (11) and the two long bolts (19) that hold the upper housing (8) and the lower housing (13) together. Carefully lifting straight up, lift the upper housing off of the lower housing.
5. Turn the large gear (10) counter-clockwise to remove it from the agitator shaft. Lift the pinion(3) and gear assembly (16) out of the lower housing.
6. Turn the 50 mm nut (26) counter-clockwise to remove it from the agitator shaft (6).
2. Thread the 50 mm nut (26) onto the agitator shaft by turning it clockwise, and tighten it hand tight.
3. Make sure the small thrust balls (4) are in place.
4. Reposition the pinion/gear assembly (3, 16) in the lower housing, thread the large gear (10) onto the agitator shaft, and tighten the large gear hand tight.
5. Carefully lowering it straight down, reposition the upper housing (8) on the lower housing (13).
6. Replace the two short bolts (11) and the two long bolts (19) that hold the upper housing (8) and the lower housing (13) together, and torque the bolts to 75 in-lb (8.5 N•m).
7. Reposition the agitator onto the drum by repeating the instructions for your agitator from step 3 in reverse order. **For agitators with and without an elevator**, torque the three hex head screws (25) to 75 in-lb (8.5 N•m) when installing.
8. If your agitator has a siphon kit, reinstall it by performing the reverse of steps 2–4 in **Cleaning an Agitator with a Siphon Kit**, page 22.

Cleaning and Servicing

1. Clean any foreign material off of the outside of the upper housing (8) and the lower housing (13).

NOTE: Do not lose the two small thrust balls (4). One is in the upper housing (8), and one is in the lower housing (13).

2. Inspect the parts for any wear. If any of the parts are worn or damaged, replace them. The Bearing Replacement Kit contains replacement bearings and seals (items 2, 7, 9, 12, 14, and 15).

Reassembling

NOTE: See **Models 26B630, 26B631, 238250**, page 34 for proper bearing and seal placement and orientation.

1. Reposition the agitator shaft (6) through the lower housing (13).

NOTICE

To prevent damage to the bearings and seals, avoid scraping them against the threaded agitator shaft while you are lowering the lower housing in place.

Service



Moving parts, such as an impeller blade, can cut or amputate fingers. To reduce the risk of serious injury, always shut off the agitator and disconnect the air line before checking or repairing the agitator.

If the air motor requires more than installation of a service kit, it is usually quickest and easiest to send it to a Graco distributor for repair or replacement.

Motor rebuild kits are available. See manual 3A5050 for more information.

Removing the Air Motor

Models 25C528, 25C529, 25C533, 25M481

1. Follow the **Pressure Relief Procedure**, page 20.
2. Remove the air regulator by unscrewing the swivel fitting (12).
 - See **Model 25C528**, page 26
 - See **Model 25C529**, page 29
 - See **Model 25C533**, page 27
 - See **Model 25M481**, page 28
3. Loosen the upper clamp (2) and raise the motor so the upper two set screws (3) are accessible. Use a 1/8 inch hex to remove the set screws from the shaft.
4. Lift the air motor straight up off the shaft.

Models 25C534, 25C535

1. Follow the **Pressure Relief Procedure**, page 20.
2. Remove the air regulator by unscrewing the swivel fitting (11). **Models 25C534, 25C535**, page 30.
3. Remove the screws (14) holding the motor mounting plate (13) to the outlet housing (3).
4. Remove the socket head screws (2) holding the motor (1) to the mounting plate.
5. Raise the motor so the two set screws (9) in the shaft (4) are accessible. Use a 1/8 inch hex to remove the set screws from the shaft.

6. Lift the air motor straight up off the shaft.

Model 25C530

1. Follow the **Pressure Relief Procedure**, page 20.
2. Remove the air regulator by unscrewing the swivel fitting (9). See **Model 25C530**, page 31.
3. Using a 3/16 inch hex, remove the three set screws (8) on the bung adapter (4).
4. Raise the motor so the top two set screws (7) in the coupler (3) are accessible. Use a 1/8 inch hex to remove the top two set screws.
5. Lift the air motor (1) straight up off the coupler.

Models 25N881, 25N882

1. Follow the **Pressure Relief Procedure**, page 20.
2. Remove the air regulator by unscrewing the swivel fitting (5). **Models 25N881, 25N882**, page 32.
3. Remove the screws (11) holding the bung adapter (6) to the motor plate (7).
4. Lift the motor off the bung adapter (6) and remove the screws (8) that attach the motor plate (7) to the motor (1).

Models 26B618, 26B619, 26B630, 26B631, 26B632, 26B633

1. Follow the **Pressure Relief Procedure**, page 20.
2. Remove the radial piston air motor by unscrewing the set screws (18) that hold the air motor to the gearbox.
3. Lift the air motor and pinion gear (attached to motor output shaft).
4. Remove the pinion gear by unscrewing the set screw (18) to release from the output shaft of the air motor.
5. Remove the air regulator by unscrewing the swivel fitting (12).

Aligning the Outlet Housing — 25C534, 25C535 Only

NOTICE

Improper installation of the outlet housing could cause the agitator shaft to bind against the outlet housing bearing and damage it.

After repairing or replacing the outlet housing or air motor, perform the following steps:

1. Follow the **Pressure Relief Procedure**, page 20.
 2. Place the agitator in a vertical position and loosen the three outlet housing screws (14). **Models 25C534, 25C535**, page 30.
 3. Apply 25 psi (1.7 bar) minimum air pressure to the air regulator (12). Adjust the air regulator so the agitator shaft is barely turning.
 4. While the agitator shaft is turning, torque the three outlet housing screws to 80 to 100 in-lbs (9 to 11.3 N•m).
 5. If the agitator shaft binds, repeat steps 1 to 3 above.
- c. Slide the shaft (2) out of the coupler.
 - d. Slide the new shaft into the coupler. Use a 1/8 inch hex to tighten the two lower setscrews in the coupler. Torque to 65 in-lb (7.3 N•m).
 - e. Lower the bung adapter on the shaft or raise the shaft through the bung adapter and insert the air motor into the coupler. Use the 1/8 inch hex to tighten the two upper set screws (SS) in the coupler. Torque to 65 in-lb (7.3 N•m). See **Model 25C530**, page 31.
 - f. Raise the bung adapter and use a 3/16 inch hex to tighten the three setscrews (8) into the bung adapter. Torque to 80 in-lb (9 N•m).
 - g. Reinstall agitator into the drum.
7. If the blade needs replacing:
 - a. Use a 3 mm (1/8 inch) hex to remove the setscrew in the long (6) or short (5) blade hub and slide the hub/blade assembly off the shaft.
 - b. To install a new hub/blade assembly, slide it onto the shaft and tighten the set screw. The setscrew must always remain on the top, with the blades hanging down, so the blades pass into and out of the bung hole.
 - c. Reinstall the agitator into the drum.

Inspecting the Shaft and Agitator Blades — Model 25C530 Only

1. Follow the **Pressure Relief Procedure**, page 20.
2. Turn off/disconnect power to the agitator.
3. Remove the agitator.
4. Clean with a compatible solvent and inspect the shaft (2) and blades (5, 6) for wear or damage. See **Model 25C530**, page 31.
5. If no wear or damage is detected, reinstall the agitator into drum.
6. If the shaft needs replacing:
 - a. Remove the air motor following the steps in **Removing the Air Motor**, page 24.
 - b. Raise the bung adapter (4) to expose the bottom two setscrews (7) in the coupler (3). Use the 1/8 inch hex to remove them.

Parts

Model 25C528

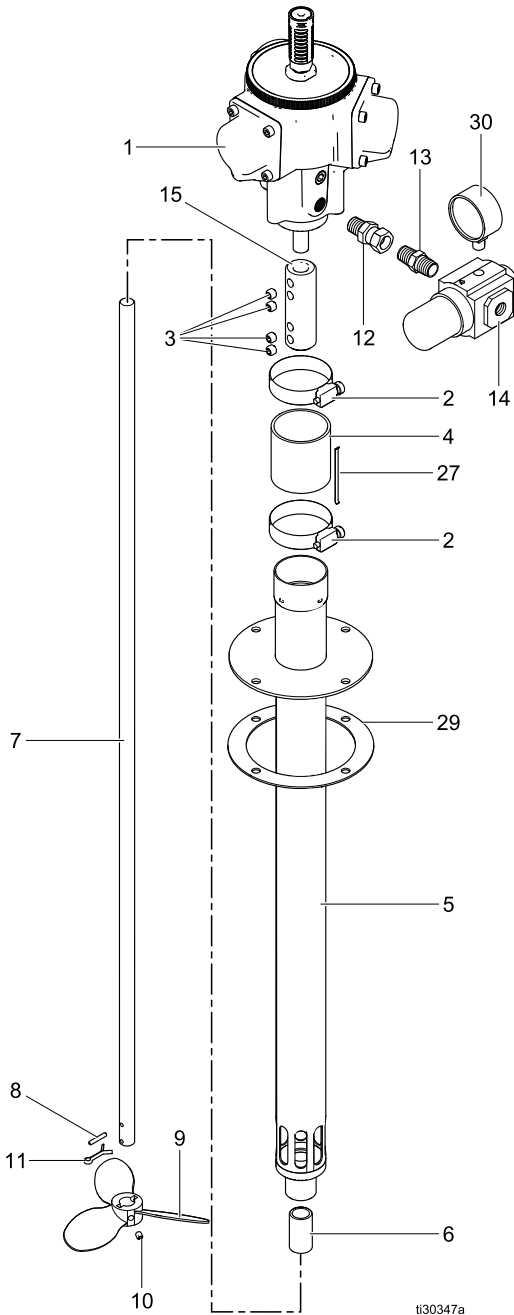

Ref.	Part	Description	Qty
1	25C765	MOTOR, Air, Rotary Piston; includes 12, 13, 14, and 30.	1
2	101368	CLAMP, Hose	2
3	100053	SCREW, Set, Socket Head; 5/16-18 x 0.25"; torque to 96-132 in-lb (11-15 N•m)	4
4	158865	COUPLING, Motor	1
5	222696	GUIDE, Agitator	1
6	115166	BEARING, Agitator, Press Fit	1
7	185389	SHAFT, Agitator	1
8	185401	PIN, Shear	1
9	185398	PROPELLER, Agitator	1
10	110248	SCREW, Set, Socket Head; #10-24 x 0.25"; torque to 15-20 in-lb (1.7-2.3 N•m)	1
11	100579	PIN, Cotter	1
12	156823	FITTING, Union, Swivel	1
13	156971	FITTING, Nipple, Short	1
14	116513	REGULATOR, Air	1
15	159858	COUPLING	1
19	100633	TOOL, Wrench, Allen (not shown)	1
20	101821	TOOL, Wrench, Allen (not shown)	1
27	065251	CABLE, Copper, Flat Braid, 0.33 ft	1
29	190192	GASKET, Guide, Agitator	1
30	104655	GAUGE, Pressure, Air	1
32▲	17P806	Safety Tag (not shown)	1

▲Replacement safety labels, signs, tags, and cards are available at no cost.

FIG. 13: Agitator Model 25C528

Model 25C533

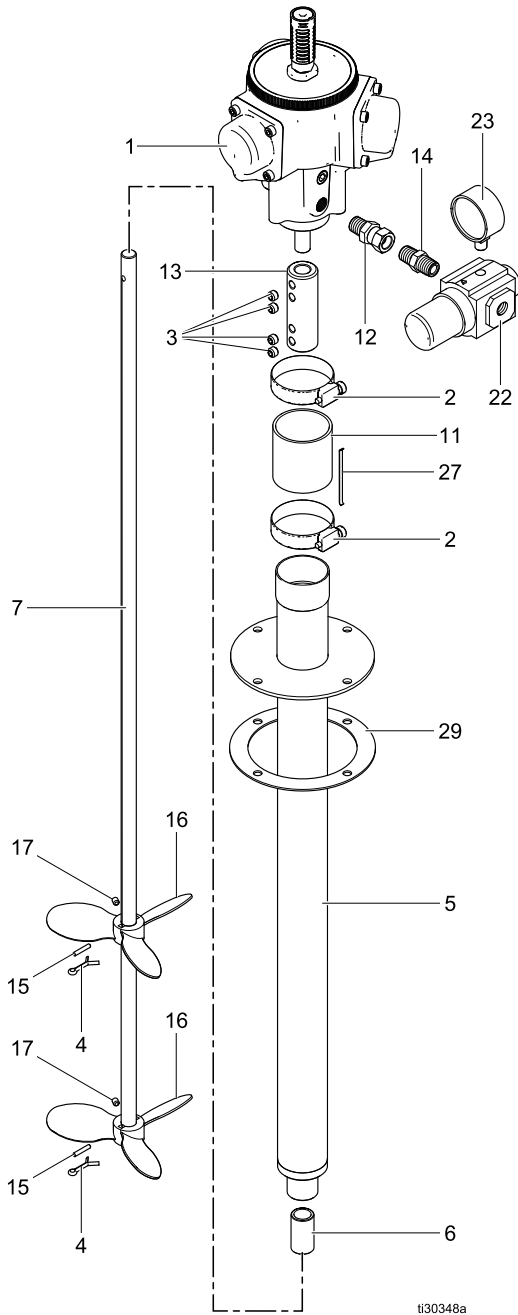

Ref.	Part	Description	Qty
1	25C765	MOTOR, Air, Rotary Piston; includes 12, 13, 14, and 30.	1
2	101368	CLAMP, Hose	2
3	100053	SCREW, Set, Socket Head; 5/16-18 x 0.25"; torque to 96-132 in-lb (11-15 N•m)	4
4	100579	PIN, Cotter	2
5	207622	GUIDE, Agitator	1
6	166565	BEARING, Agitator, Press Fit	1
7	172313	SHAFT, Agitator	1
8	100633	TOOL, Wrench, Allen (not shown)	1
9	101821	TOOL, Wrench, Allen (not shown)	1
11	158865	COUPLING, Motor	1
12	156823	FITTING, Union, Swivel	1
13	159858	COUPLING	1
14	156971	FITTING, Nipple, Short	1
15	160077	PIN, Shear	2
16	159854	PROPELLER, Agitator	2
17	101118	SCREW, Set, Socket Head; #10-24 x 0.25"; torque to 15-20 in-lb (1.7-2.3 N•m)	2
22	116513	REGULATOR, Air	1
23	104655	GAUGE, Pressure, Air	1
27	065251	CABLE, Copper, Flat Braid, 0.33 ft	1
29	190192	GASKET, Guide, Agitator	1
35▲	17P806	Safety Tag (not shown)	1

▲Replacement safety labels, signs, tags, and cards are available at no cost.

Fig. 14: Agitator Model 25C533

Model 25M481

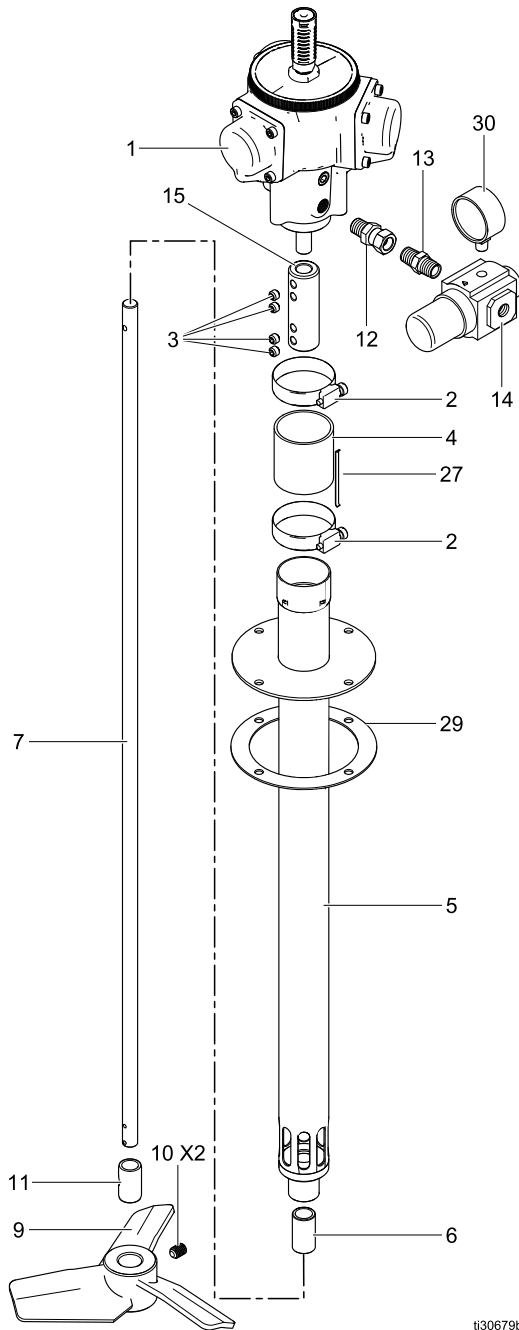

t30679b

FIG. 15: Agitator Model 25M481

Ref.	Part	Description	Qty
1	25C765	MOTOR, Air, Rotary Piston; includes 12, 13, 14, and 30.	1
2	101368	CLAMP, Hose	2
3	100053	SCREW, Set, Socket Head; 5/16-18 x 0.25"; torque to 96-132 in-lb (11-15 N•m)	4
4	158865	COUPLING, Motor	1
5	222696	GUIDE, Agitator	1
6	115166	BEARING, Agitator, Press Fit	1
7	185389	SHAFT, Agitator	1
9	17N708	IMPELLER, Hydrafoil; 8" Stainless Steel; includes item 10. Note: Install the impeller so that the bent portion of the blade is on the leading edge when turning clockwise.	1
10	---	SCREW, Set, Socket Head; 3/8-16 x 0.5"; torque to 180-200 in-lb (20-23 N•m)	2
11	17R167	SPACER, Shaft	1
12	156823	FITTING, Union, Swivel	1
13	156971	FITTING, Nipple, Short	1
14	116513	REGULATOR, Air	1
15	159858	COUPLING	1
19	100633	TOOL, Wrench, Allen (not shown)	1
20	101821	TOOL, Wrench, Allen (not shown)	1
27	065251	CABLE, Copper, Flat Braid, 0.33 ft	1
29	190192	GASKET, Guide, Agitator	1
30	104655	GAUGE, Pressure, Air	1
32▲	17P806	Safety Tag (not shown)	1
▲Replacement safety labels, signs, tags, and cards are available at no cost.			

Model 25C529

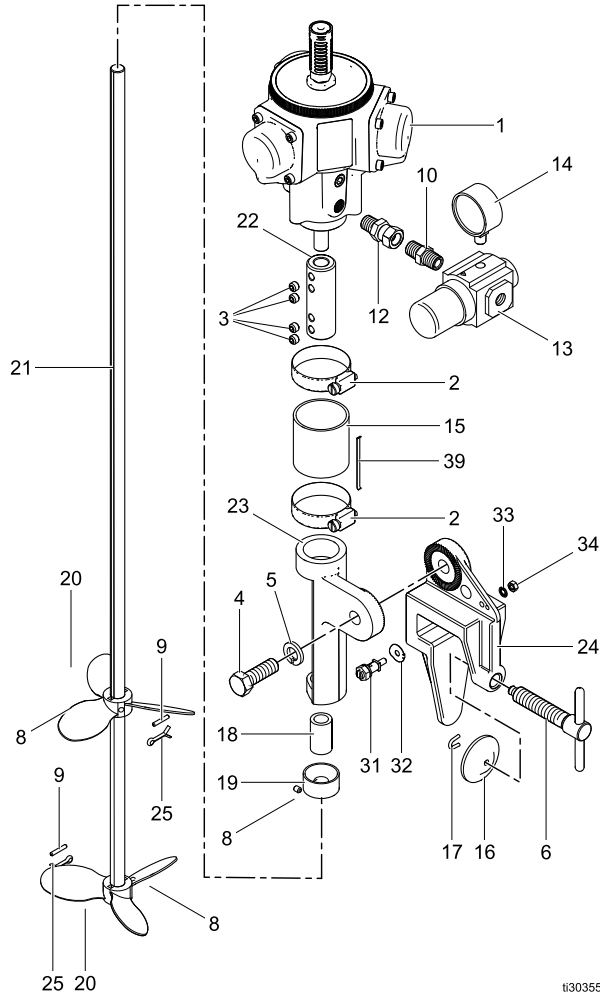
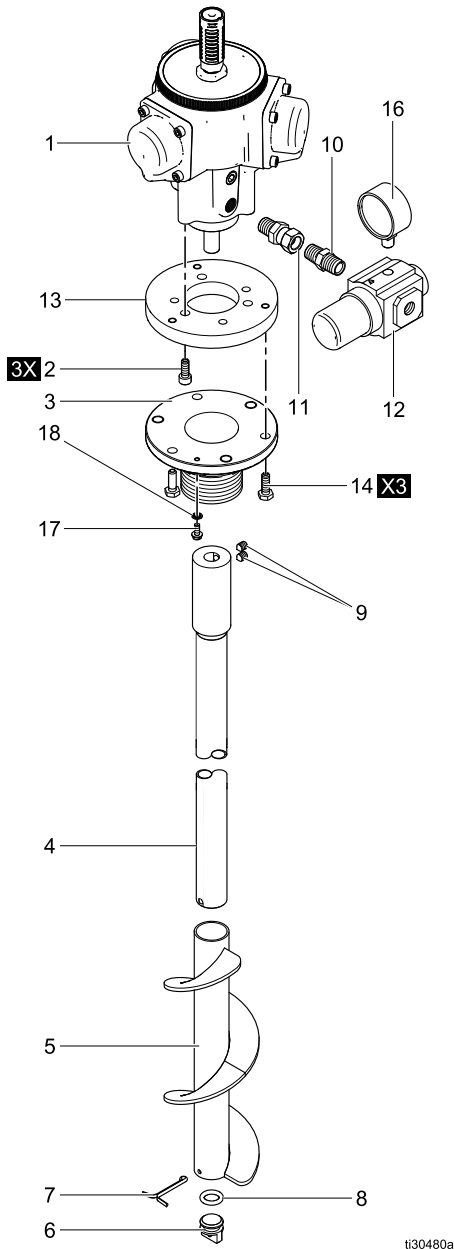

Fig. 16: Agitator Model 25C529

Ref.	Part	Description	Qty
1	25C765	MOTOR, Air, Rotary Piston; includes 12, 13, 14, and 30.	1
2	101368	CLAMP, Hose	2
3	100053	SCREW, Set, Socket Head; 5/16-18 x 0.25"; torque to 96-132 in-lb (11-15 N•m)	4
4	100017	SCREW, Cap, Hex Head; 1/2-13 x 1.5"; tighten securely; do not over-tighten	1
5	100018	WASHER, Lock, Spring	1
6	203399	CLAMP, Screw	1
7	100633	TOOL, Wrench, Allen (not shown)	1
8	101118	SCREW, Set, Socket Head; #10-24 x 0.25"; torque to 15-20 in-lb (1.7-2.3 N•m)	3
9	160077	PIN, Shear	2
10	156971	FITTING, Nipple, Short	1
11	101821	TOOL, Wrench, Allen (not shown)	1
12	156823	FITTING, Union, Swivel	1
13	116513	REGULATOR, Air	1
14	104655	GAUGE, Pressure, Air	1
15	158865	COUPLING, Motor	1
16	159056	PAD, Mounting, Screw	1
17	159057	RETAINER	1
18	104391	BEARING, Agitator, Press Fit	1
19	159704	CUP, Protector, Bearing	1
20	159854	PROPELLER, Agitator	2
21	172311	SHAFT, Agitator	1
22	159858	COUPLING	1
23	159863	BRACKET, Mounting	1
24	159864	CLAMP, Agitator	1
25	100579	PIN, Cotter	2
31	104029	CLAMP, Ground, Electric	1
32	104582	WASHER, Tab	1
33	100718	WASHER, Lock	1
34	110911	NUT, Hex; M5 x 8	1
37	186620	LABEL, Symbol, Ground (not shown)	1
39	065251	CABLE, Copper, Flat Braid, 0.33 ft	1
43▲	17P806	Safety Tag (not shown)	1

▲Replacement safety labels, signs, tags, and cards are available at no cost.

Models 25C534, 25C535



Ref.	Part	Description	Qty
1	25C765	MOTOR, Air, Rotary Piston; includes 12, 13, 14, and 30.	1
2	124313	SCREW, Socket Head; M6-1 x 16 mm, Stainless Steel; torque to 80-100 in-lb (9-11 N•m)	3
3	235535	HOUSING, Agitator Outlet, Stainless Steel (model 25C534)	1
	224876	HOUSING, Agitator Outlet, Carbon Steel (model 25C535)	1
4	235530	SHAFT, Agitator (model 25C534)	1
	224852	SHAFT, Agitator (model 25C535)	1
5	224393	HELIX, Agitator	1
6	187054	PLUG, Tube, Fluid	1
7	101946	PIN, Cotter; Stainless Steel	1
8	111312	PACKING, O-ring	1
9	112364	SCREW, Set, Socket Head; 1/4-20 x 0.38";	2
		torque to 35-40 in-lb (4-5 N•m)	
10	156823	FITTING, Nipple, Short	1
11	156971	FITTING, Union, Swivel	1
12	116513	REGULATOR, Air	1
13	187577	PLATE, Mounting, Motor	1
14	102023	SCREW, Cap, Hex Head; 1/4-20 x 0.75"; torque to 80-100 in-lb (9-11 N•m)	3
16	104655	GAUGE, Pressure, Air	1
17	111593	SCREW, Grounding, Slotted Hex Washer Head; #8-32 x 0.375"	1
18	157021	WASHER, Lock, Internal	1
19	186620	LABEL, Symbol, Ground (not shown)	1
27	403123	CAP, Plug (not shown)	1
30▲	17P806	Safety Tag (not shown)	1
▲Replacement safety labels, signs, tags, and cards are available at no cost.			

FIG. 17: Agitator Models 25C534, 25C535

Model 25C530

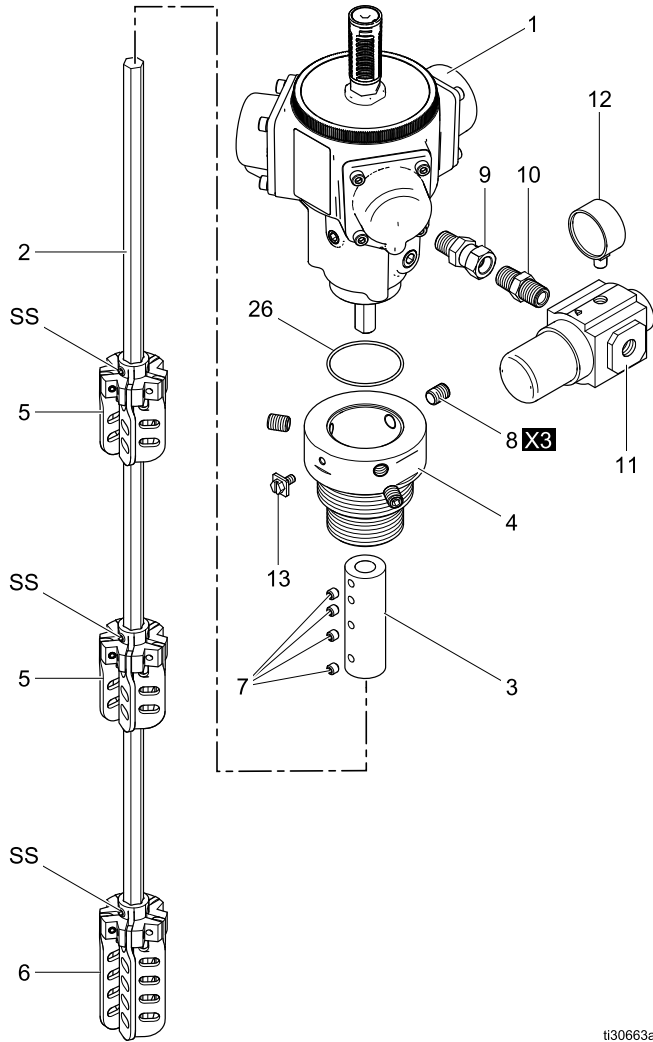
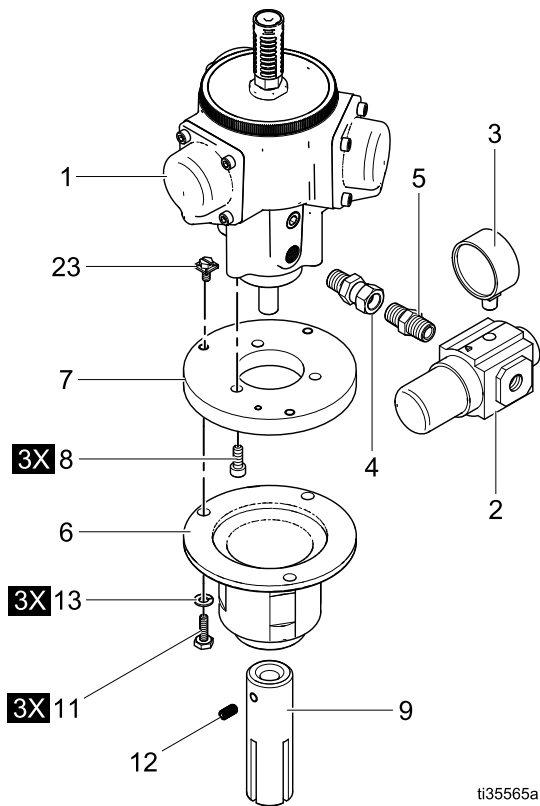

FIG. 18: Agitator Model 25C530

Ref.	Part	Description	Qty
SS	— — —	SCREW, Blade Set; tighten securely after adjusting; do not over-tighten	3
1	25C765	MOTOR, Air, Rotary Piston; includes 12, 13, 14, and 30.	1
2	16A867	SHAFT, Agitator	1
3	16A868	COUPLER, Agitator	1
4	16A872	ADAPTER, Bung, Double	1
5	24C860	AGITATOR, Arm, Short	2
6	24C861	AGITATOR, Arm, Long	1
7	102207	SCREW, Set, Socket Head; 1/4-20 x 0.25"; torque to 96-132 in-lb (11-15 N•m)	4
8	101679	SCREW, Set, Socket Head; 3/8-24 x 0.5"; torque to 80-100 in-lb (9-11 N•m)	3
9	156823	FITTING, Union, Swivel	1
10	156971	FITTING, Nipple, Short	1
11	116513	REGULATOR, Air	1
12	104655	GAUGE, Pressure, Air	1
13	116343	SCREW, Ground; M5 x .8	1
25	186620	LABEL, Symbol, Ground (not shown)	1
26	113082	PACKING, O-ring	1
27	16H294	ADAPTER, Angled, Expanding Blade (not shown)	1
28	16H295	RING, Locking (not shown)	1
30▲	17P806	Safety Tag (not shown)	1
▲Replacement safety labels, signs, tags, and cards are available at no cost.			

Models 25N881, 25N882



ti35565a

FIG. 19: Agitator Models 25N881, 25N882

Ref.	Part	Description	Qty.
1	25C765	MOTOR, Air, Radial Piston; includes items 2, 3, 4, and 5	1
2	116513	REGULATOR, Air	1
3	104655	GAUGE, Pressure, Air	1
4	156971	FITTING, Nipple, Short	2
5	156823	FITTING, Union, Swivel	1
6	16A521	HOUSING, Adapter, 1 1/2–11.5 NPSM (model 25N881)	1
	16A754	HOUSING, Adapter, 2–11.5 NPSM (model 25N882)	
7	18A192	PLATE, In-Drum Mounting	1
8	117028	SCREW, Socket Head, M6–1 x 16 mm; torque to 80–100 in-lb (9–11 N•m)	3
9	17X562	ADAPTER, Shaft, 7/16" Square	1
	17X563	ADAPTER, Shaft, 1/2" Square	1
11	555337	SCREW, Hex Head 1/4–20 x .750; torque to 80–100 in-lb (9–11 N•m)	3
12	131497	SCREW, Set, Cup pt, 1/4–20 x .500; Tighten securely on flat of motor shaft.; use a light strength anaerobic sealant	1
13	100016	WASHER, Lock	3
22	116343	SCREW, Ground	1
24▲	17P806	Safety Tag (not shown)	1

▲Replacement safety labels, signs, tags, and cards are available at no cost.

Model 19Y592

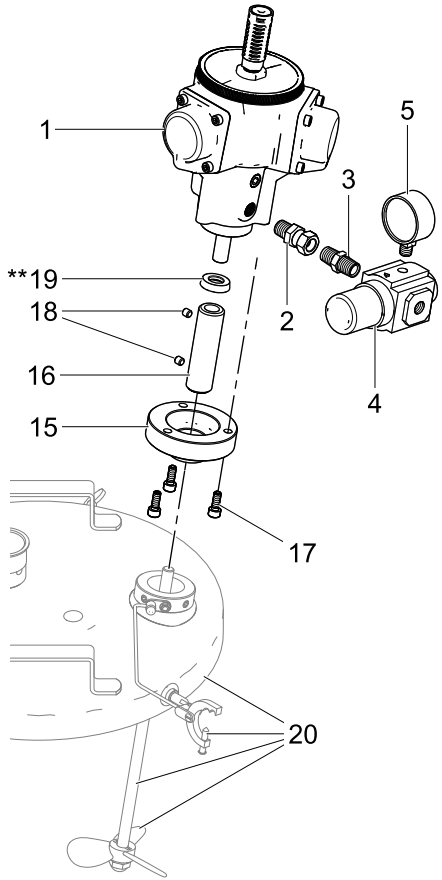

ti37867b

FIG. 1: Agitator Model 19Y592

** The splash seal lips (the concave surface) should face down (away) from the motor.

Ref.	Part	Description	Qty
1	25C765	MOTOR, Air, Radial Piston; includes items 2, 3, 4, and 5	1
2	156823	FITTING, Union, Swivel	1
3	156971	FITTING, Nipple, Short	1
4	116513	REGULATOR, Air	1
5	104655	GAUGE, Press Air	1
10▲	17Z460	Safety Tag (not shown)	1
15	25P708	ADAPTER, Agitator, Mount, 5 Gallon	1
16	25P709	COUPLER, Shaft, Agitator, 1/2 - 3/8 Inch	1
17	124313	SCREW, SHCS, M6-1X16M, SST	1
18	110272	SCREW, Set, SCH	1
19	19C987	SEAL, Splash	1
20	The pail cover, shaft, and blade are not part of the kit. See manual 306670 to order the pail cover and related parts.		
▲Replacement safety labels, signs, tags, and cards are available at no cost.			

Models 26B630, 26B631, 238250

6:1 Gear Reduction Agitator, Model 26B630 (includes items 1–34)

6:1 Gear Reduction Agitator with Siphon Kit, Model 26B631 (includes items 1–34 and 50a–50e)

Siphon Kit, Model 238250 (includes items 50a–50e)

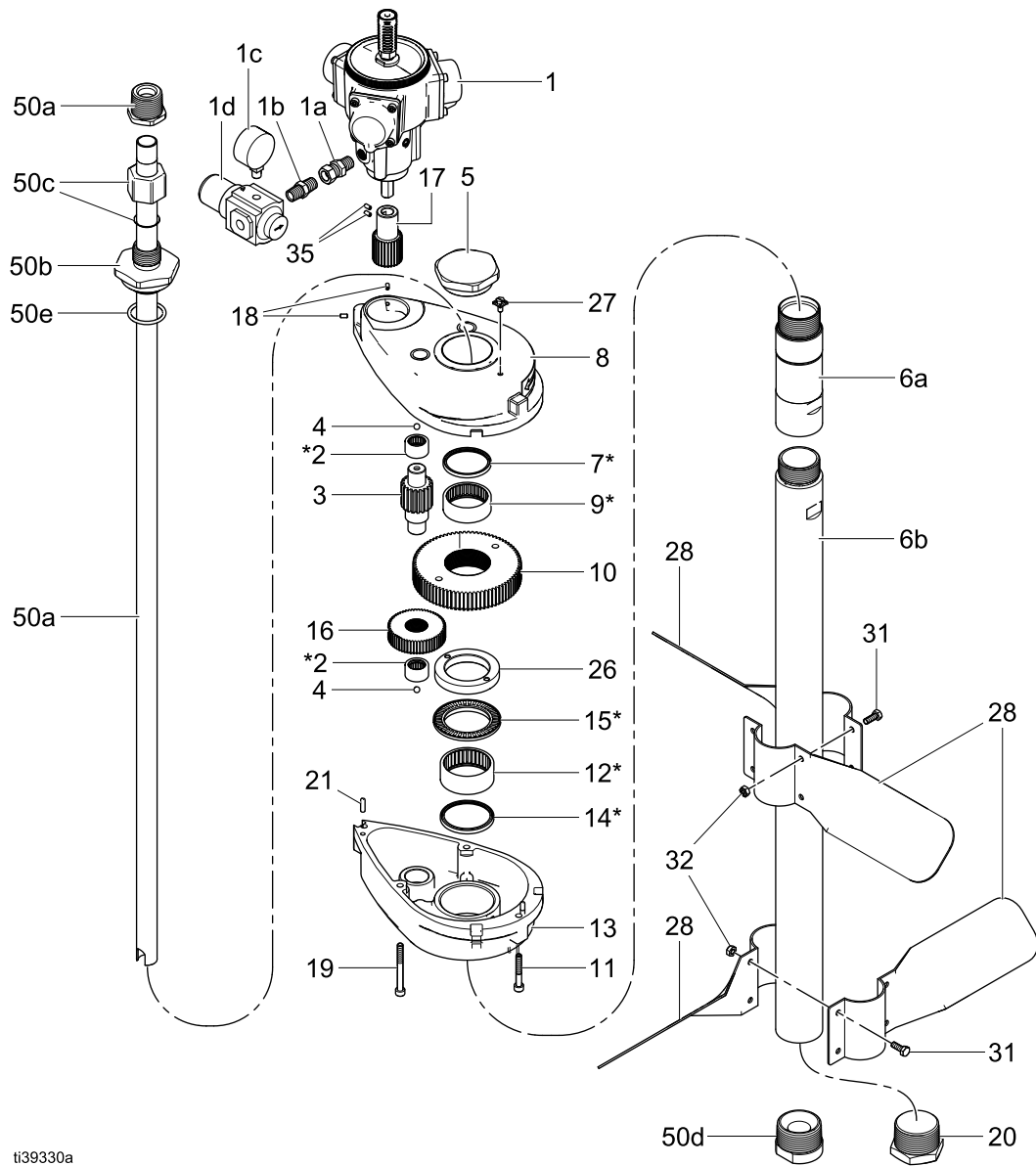

ti39330a

FIG. 1: Siphon Kit, Model 238250

Models 26B630, 26B631, 238250

Ref.	Part	Description	Qty
1†	25C765	KIT, MOTOR, RADIAL PISTON AIR (includes items 1a–1d)	1
1a	18A823	MOTOR, air	1
1b	156823	FITTING, union, swivel	1
1c	104655	GAUGE, press air	1
1d	116513	REGULATOR, air	1
2*	191004	BEARING, needle; 3/4"	2
3	18D110	GEAR, pinion #2	1
4	100069	BALL, thrust	2
5	191003	PLUG, top	1
6	24D311	KIT, agitator shaft (includes items 6a and 6b)	1
6a	16A519	SHAFT, agitator	1
6b	16C238	SHAFT, agitator	1
7*	113363	SEAL, bearing	1
8	194389	HOUSING, upper	1
9*	190980	BEARING, needle, 45 mm	1
10	18D111	GEAR #2	1
11	113357	SCREW, cap, socket head	2
12*	190978	BEARING, needle, 50 mm	1
13	194390	HOUSING, lower	1
14*	113359	SEAL, bearing	1
15*	190979	BEARING, needle, thrust; 50 mm	1
16	18D109	GEAR #1	1
17	18D108	GEAR, pinion #1	1
18	108161	SET SCREW, cup pt; SST	2
19	113356	SCREW, cap, socket head	2
20	191002	PLUG, bottom	1
21	105489	PIN, dowel	2
25	113358	SCREW, hex head; for mounting to drum cover (see Mounting Hole Layouts , page 44)	3
26	190976	NUT; 50 mm	1
27	116343	SCREW, ground	1
28	190985	BLADE, agitator	4
30▲	17P806	Safety Tag (not shown)	1
31	113413	SCREW, cap	8
32	113414	NUT, lock	8
35	103253	SCREW, set, hex soc	2
† Motor rebuild kits are available. For more information, see Service , page 24.			
* Included in Bearing Replacement Kit 238251.			
▲ Replacement safety labels, signs, tags, and cards are available at no cost.			

NOTE: Agitator Drive Kit 25T862 is available. The kit includes all of the above parts except items 6b, 20, 28, 31, and 32.

Siphon Kit, Model 238250

Ref.	Part	Description	Qty
50a	238161	TUBE, siphon	1
		FITTING, threaded	1
50b	190998	RETAINER, siphon tube	1
50c	190999	NUT, retaining	1
50d	191000	BEARING, plain	1
50e	164557	O-RING; PTFE	1

Models 26B618, 26B619

6:1 Gear Reduction Agitator, Drum Mounted, Models 26B619, and 26B618 (for drums with built-in shaft and blades)

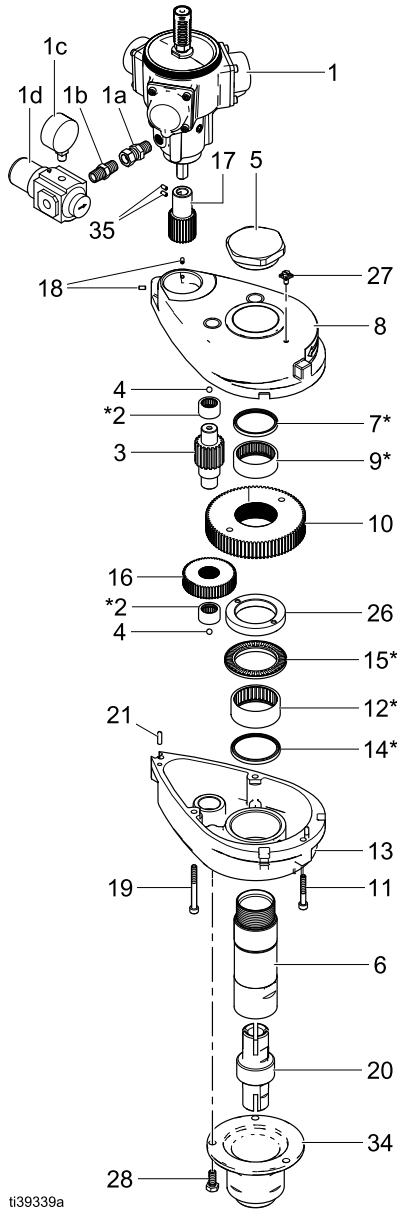

FIG. 1: Models 26B618, 26B619

Models 26B618, 26B619

Ref.	Part	Description	Qty.
1†	25C765	KIT, MOTOR, RADIAL PISTON AIR	1
1a	18A823	MOTOR, air	1
1b	156823	FITTING, union, swivel	1
1c	104655	GAUGE, press air	1
1d	116513	REGULATOR, air	1
2	191004	BEARING, needle; 3/4"	2
3	18D110	GEAR, pinion #2	1
4	100069	BALL, thrust	2
5	191003	PLUG, top	1
6	16A519	SHAFT, agitator	1
7*	113363	SEAL, bearing	1
8	194389	HOUSING, upper	1
9*	190980	BEARING, needle, 45 mm	1
10	18D111	GEAR #2	1
11	113357	SCREW, cap, socket head	2
12*	190978	BEARING, needle, 50 mm	1
13	194390	HOUSING, lower	1
14*	113359	SEAL, bearing	1
15*	190979	BEARING, needle, thrust; 50 mm	1
16	18D109	GEAR #1	1
17	—	GEAR, pinion #1	1
18	108161	SET SCREW, cup pt; SST	2
19	113356	SCREW, cap, socket head	2
20?	16H554	ADAPTER, nut, double-sided (7/16 and 3/8)	1
	16H555	ADAPTER, nut (1/2 and 5/8)	1
21	105489	PIN, dowel	2
25	113358	SCREW, hex head; for mounting to drum cover (see Mounting Hole Layouts , page 44)	3
26	190976	NUT; 50 mm	1

Ref.	Part	Description	Qty.
27	116343	SCREW, grounding	1
28	113358	SCREW, cap, hex	3
30▲	17P806	Safety Tag (not shown)	1
34◆	16A521	HOUSING, adapter (for 26B619)	1
	16A754	HOUSING, adapter (for 26B618)	1
35	103253	SCREW, set, hex soc	2
† Motor rebuild kits are available. For more information, see Service , page 24.			
* Included in Bearing Replacement Kit 238251.			
~ Item not saleable.			
◆ Included in Adapter Kit 24D588.			
▲ Replacement safety labels, signs, tags, and cards are available at no cost.			

NOTE: Agitator Drive Kit 25T862 is available. The kit includes all of the above parts except items 20 and 34.

Models 26B632, 26B633

Non-Siphon Agitator Package, 6:1 Gear Reduction, Model 26B632

Siphon Agitator Package, Model 26B633 (shown)

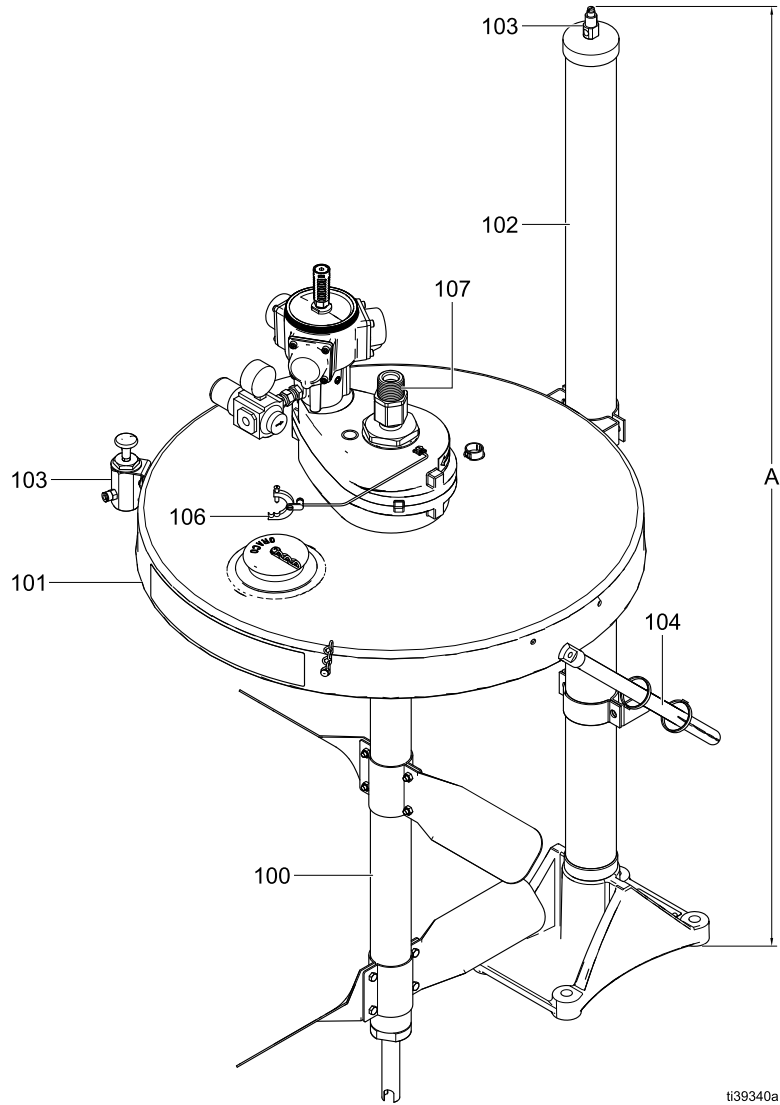

FIG. 1: Agitator Package, Model 26B633

Reference A =Raised height: 94 in. (239 cm)

Lowered height: 55 in. (140 cm)

Models 26B632, 26B633

Ref.	Part	Description	Qty.
100	26B630	AGITATOR, 6:1 GEAR REDUCTION; (for parts, see Models 26B630, 26B631, 238250, page 33)	1
101	238283	COVER, sst; see manual 308466	1
102	204385	ELEVATOR; see manual 306287	1
103	237579	AIR CONTROL KIT; see manual 306287	1
104	237578	COVER SUPPORT KIT; see manual 306287	1
105	238425	DESIGNATION PLATE KIT; Model 231413 (not shown)	1
	2001050	DESIGNATION PLATE KIT; Model 26B633 (not shown)	1
	2001051	DESIGNATION PLATE KIT; Model 26B632 (not shown)	1
106	237569	GROUND WIRE AND CLAMP	1
107	238250	SIPHON KIT; Model 231414 only; (for parts, see Models 26B630, 26B631, 238250, page 33)	1

Accessories

Sensor Kit 25C373

Use the Sensor Kit 25C373 for sensing motor revolution. The kit includes a sensor and sensor bracket for mounting to the air motor.

DataTrak Kit 25P394

Use the DataTrak Kit 25P394 for monitoring speed and totalizing revolutions of radial piston motor driven agitators.

Dimensions

Models 25C528 and 25C533

Model 25M481

Model 25C529

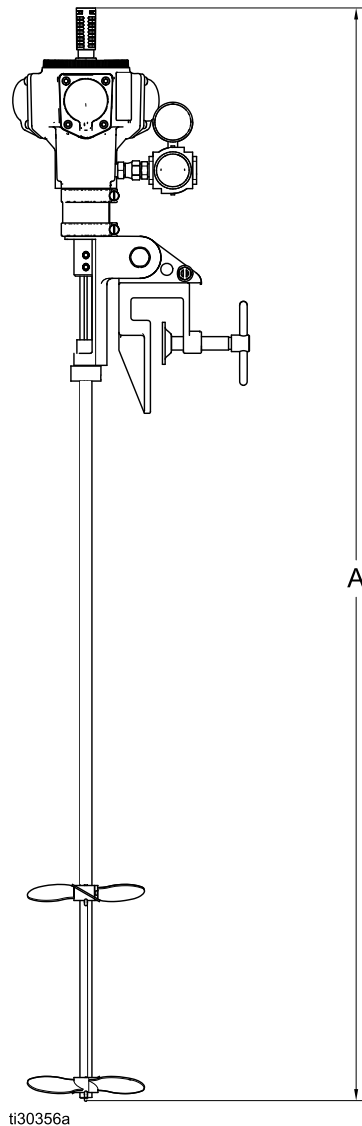
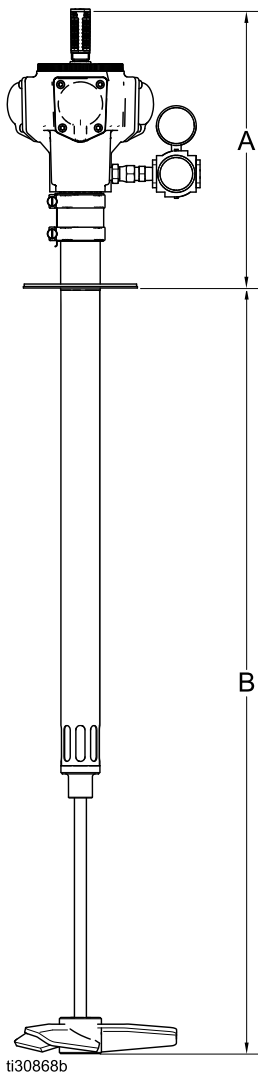
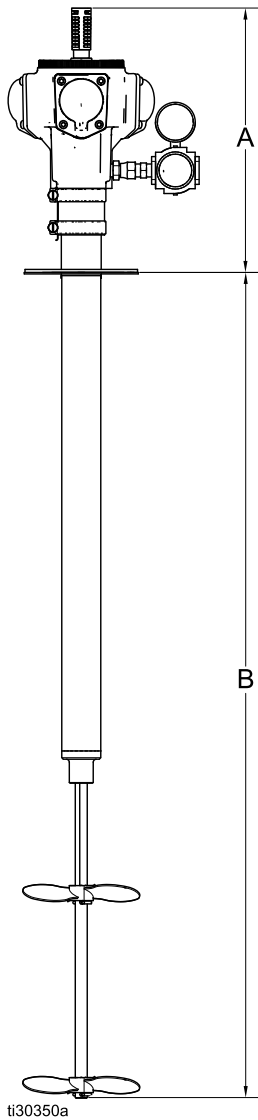

Reference A = 11.5 in. (29.3 cm)
Reference B Model 25C528 = 31.9 in (81.0 cm) Model 25C533 = 34.3 in. (87.2 cm)

Reference A = 11.5 in. (29.3 cm)
Reference B = 31.9 in (81.0 cm)

Reference A = 45.6 in. (115.8 cm)

Dimensions

Models 25C534 and 25C535

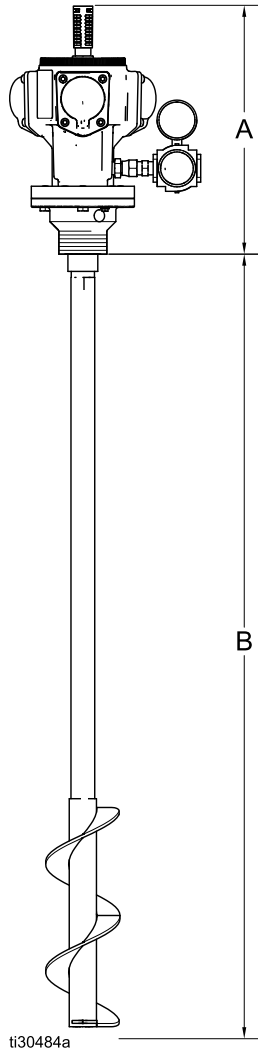

Model 25C530

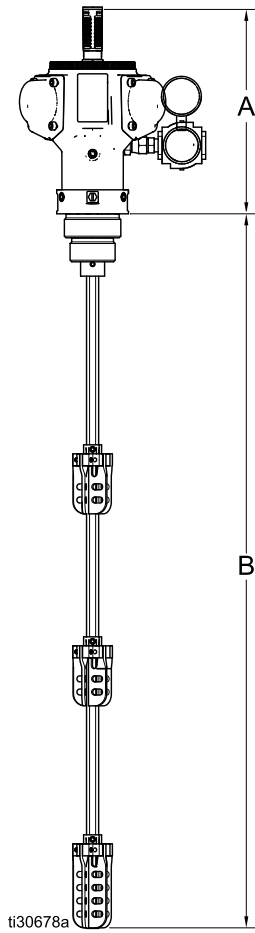

Models 25N881 and 25N882

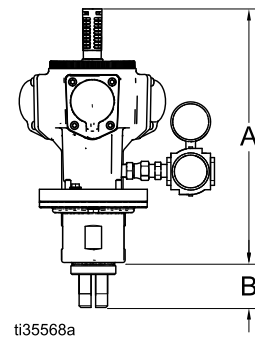

Reference A = 10.4 in. (26.3 cm)
Reference B = 32.2 in. (81.8 cm)

Reference A = 8.5 in. (21.6 cm)
Reference B = 29.8 in. (75.6 cm)

Reference A = 10.4 in. (26.3 cm)
Reference B = 32.2 (81.8 cm)

Models

26B631

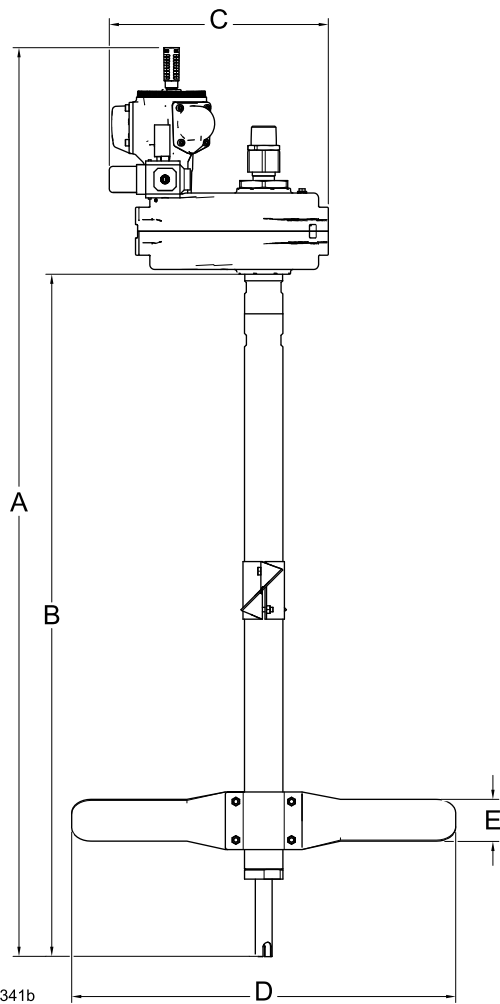

Reference A = 48 in. (1219 mm)
Reference B = 36 in. (914 mm)
Reference C = 10 in. (254 mm)
Reference D = 20 in. (508 mm)
Reference E = 3 in. (76 mm)

26B630

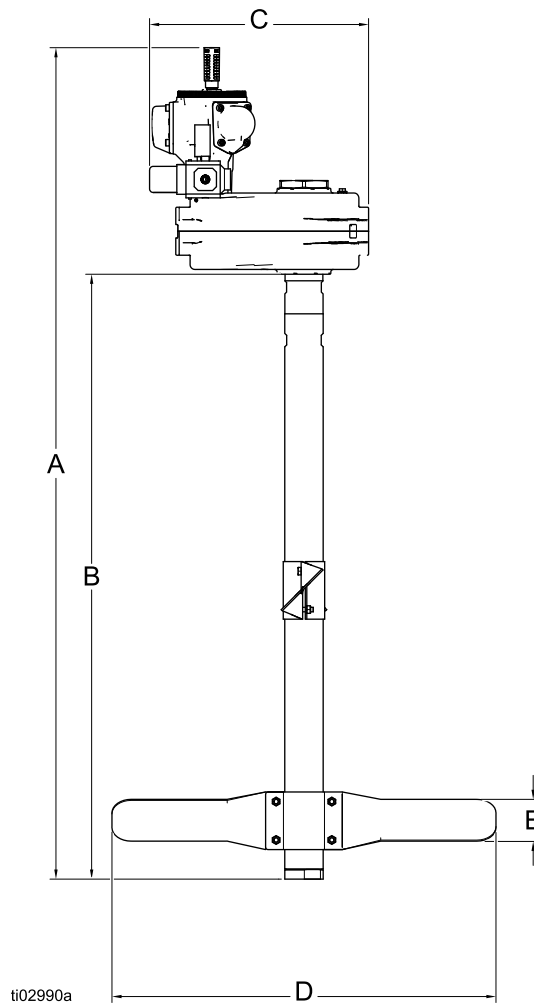

Reference A = 44 in. (1118 mm)
Reference B = 32 in. (813 mm)
Reference C = 10 in. (254 mm)
Reference D = 20 in. (508 mm)
Reference E = 3 in. (76 mm)

Mounting Hole Layouts

Models 25C528, 25C533, 25M481

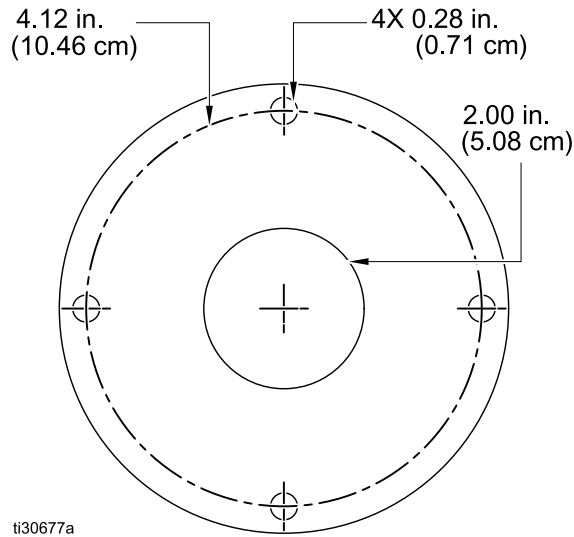

Models 26B618, 26B619, 26B630, 26B631, 26B632, 26B633, and 25T862

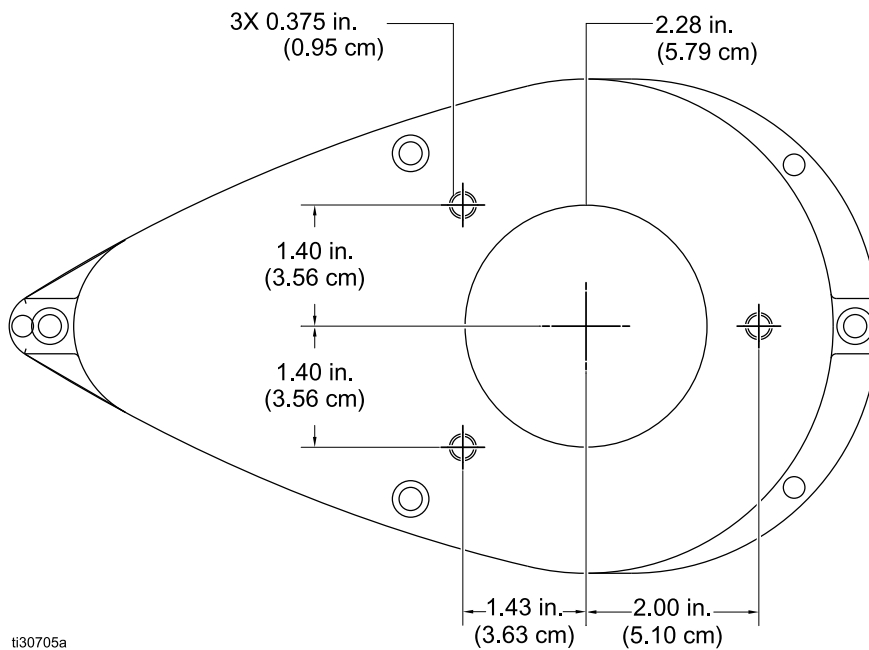

Air Consumption

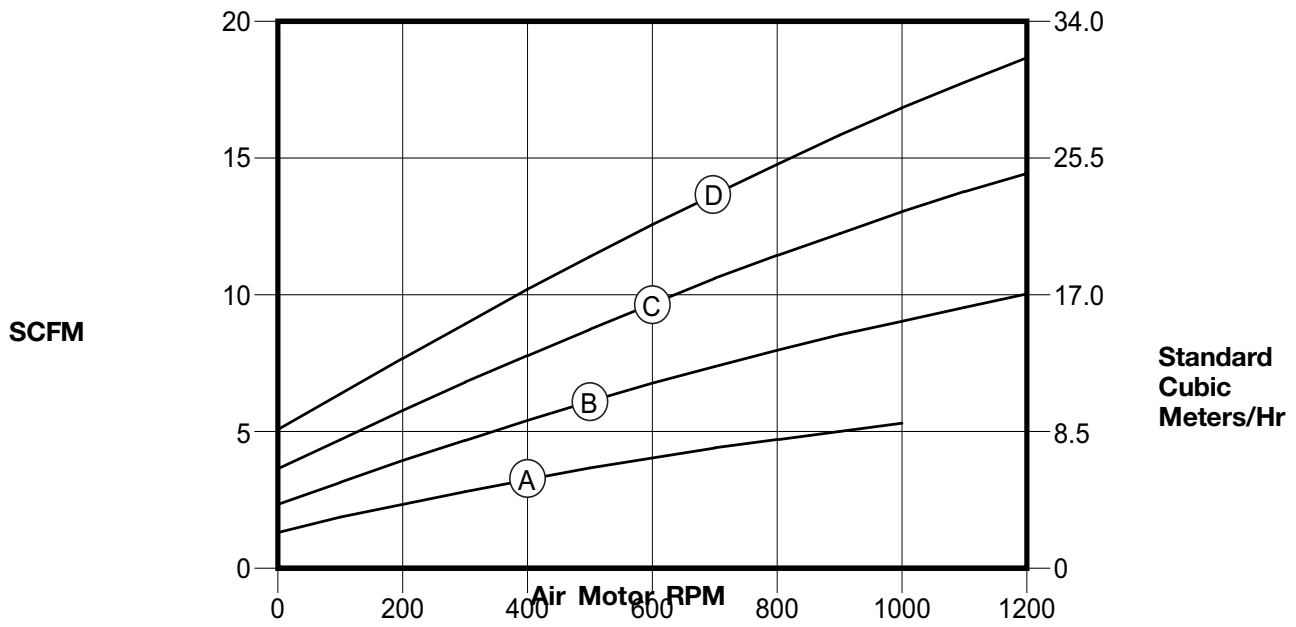

A — 20 psi (1.4 bar, 0.14 MPa)

B — 40 psi (2.8 bar, 0.28 MPa)

C — 60 psi (4.1 bar, 0.41 MPa)

D — 80 psi (5.5 bar, 0.55 MPa)

Technical Specifications

NOTE: Operating above recommended maximum speeds increases wear on components and decreases operating efficiencies.

Models 25C528, 25C533, 25M481

Air-Driven Agitators, Standard			
	25C528	25C533	25M481
Maximum Recommended Working Pressure	70 psig (5 bar)		
Air Consumption	See chart		
Maximum Recommended Speed	500 rpm		500 rpm
Maximum Allowable Process Fluid Temperature	194° F (90° C)		
Maximum Recommended Material Viscosity	1000 cP		500 cP
Wetted Parts	Stainless Steel, Polyether Ether Keytone	Carbon Steel, Aluminum, PTFE	Stainless Steel, Polyether Ether Keytone
Weight	11 lb (5 kg)	12 lb (5.4 kg)	13 lb (5.9 kg)
Sound Pressure Level at 70 psig, Maximum Recommended Speed	Less than 75 dBA		

Model 25C529

Air-Driven Agitator, Outboard	
Maximum Recommended Working Pressure	70 psig (5 bar)
Air Consumption	See chart
Maximum Recommended Speed	500 rpm
Maximum Recommended Material Viscosity	1000 cP
Wetted Parts	Aluminum, carbon steel, ductile iron, bronze
Weight	15 lb (6.8 kg)
Sound Pressure Level at 70 psig, Maximum Recommended Speed	Less than 75 dBA

Models 25C534, 25C535

Air-Driven Agitators, Twistork® Helix Mixer		
Maximum Recommended Working Pressure		70 psig (5 bar)
Air Consumption		See chart
Maximum Recommended Speed		500 rpm
Maximum Allowable Process Fluid Temperature		158° F (70° C)
Maximum Recommended Material Viscosity		1000 cP
Wetted Parts		
	25C535	Carbon Steel, Fluoroelastomer, Acetal
	25C534	304 and 316 Stainless Steel, Fluoroelastomer, Acetal
Weight		16 lb (7.3 kg)
Sound Pressure Level at 70 psig, Maximum Recommended Speed		Less than 75 dBA

Model 25C530

Air-Driven Agitators, Expanding Blade Mixer	
Maximum Recommended Working Pressure	70 psig (5 bar)
Air Consumption	See chart
Maximum Recommended Speed	500 rpm
Maximum Allowable Process Fluid Temperature	194° F (90° C)
Maximum Recommended Material Viscosity	1000 cP
Bung Adapter Sizes	1 1/2–11.5 npsm and 2–11.5 npsm
Wetted Parts	303, 304, 18–8 stainless steel
Weight	12 lb (5.4 kg)
Sound Pressure Level at 70 psig, Maximum Recommended Speed	Less than 75 dBA

Models 25N881, 25N882

Air-Driven Agitators, In Drum	
Maximum Recommended Working Pressure	70 psig (5 bar)
Air Consumption	See chart
Maximum Recommended Speed	100 rpm
Maximum Allowable Process Fluid Temperature	194° F (90° C)
Maximum Recommended Material Viscosity	500 cP
Bung Adapter Sizes	1 1/2–11.5 npsm and 2–11.5 npsm
Wetted Parts	N/A
Weight	11.4 lb (5.2 kg)
Sound Pressure Level at 70 psig, Maximum Recommended Speed	Less than 75 dBA

Model 19Y592

Air-Driven Agitator, In Pail	
Maximum Recommended Working Pressure	70 psig (5 bar)
Air Consumption	See chart
Maximum Recommended Speed	500 rpm
Maximum radial load allowed on shaft	30 lbf, 0.13 kN
Maximum thrust load allowed on shaft	11 lbf, 0.05 kN
Maximum Allowable Process Fluid Temperature	194° F (90° C)
Maximum Recommended Material Viscosity	500 cP
Weight	7.4 lb (3.4 kg)
Sound Pressure Level at 70 psig, Maximum Recommended Speed	Less than 75 dBA

Model 25C765

Air-Driven Agitator, In Pail	
Maximum Recommended Working Pressure	70 psig (5 bar)
Air Consumption	See chart
Maximum Recommended Speed	500 rpm
Maximum radial load allowed on shaft	30 lbf, 0.13 kN
Maximum thrust load allowed on shaft	11 lbf, 0.05 kN
Maximum Allowable Process Fluid Temperature	194° F (90° C)
Maximum Recommended Material Viscosity	500 cP
Weight	8 lb (3.6 kg)
Sound Pressure Level at 70 psig, Maximum Recommended Speed	Less than 75 dBA

Models 26B618, 26B619, 26B630, 26B631, 26B632, 26B633, 25T862

Air-Driven Back Geared Agitator	
Maximum Recommended Working Pressure	70 psi (0.5 MPa , 5 bar)
Air Consumption	See chart
Maximum Recommended Shaft RPM (agitator)	83 rpm
Recommended Material Viscosity	500 cP – 3000 cP
Wetted Parts	300 series stainless steel, nylon, acetal, PTFE
Weights: 26B618 26B619 26B630 26B631 26B632 26B633 25T862	11 lb (5 kg) 11 lb (5 kg) 40 lb (18.1 kg) 30 lb (13.6 kg) 129 lb (58.5 kg) 134 lb (60.8 kg) 18 lb (8.2 kg)
Gear Reducer Ratio	6:1
Sound Pressure Level at 70 psig, Maximum Recommended Speed	Less than 75 dBA
Span of agitator blades	20 in (508 mm)
Width of agitator blades	3 in. (76 mm)
Siphon tube ID	¾ in. (19 mm)

California Proposition 65

CALIFORNIA RESIDENTS

 **WARNING:** Cancer and reproductive harm — www.P65warnings.ca.gov.

Graco Standard Warranty

Graco warrants all equipment referenced in this document which is manufactured by Graco and bearing its name to be free from defects in material and workmanship on the date of sale to the original purchaser for use. With the exception of any special, extended, or limited warranty published by Graco, Graco will, for a period of twelve months from the date of sale, repair or replace any part of the equipment determined by Graco to be defective. This warranty applies only when the equipment is installed, operated and maintained in accordance with Graco's written recommendations.

This warranty does not cover, and Graco shall not be liable for general wear and tear, or any malfunction, damage or wear caused by faulty installation, misapplication, abrasion, corrosion, inadequate or improper maintenance, negligence, accident, tampering, or substitution of non-Graco component parts. Nor shall Graco be liable for malfunction, damage or wear caused by the incompatibility of Graco equipment with structures, accessories, equipment or materials not supplied by Graco, or the improper design, manufacture, installation, operation or maintenance of structures, accessories, equipment or materials not supplied by Graco.

This warranty is conditioned upon the prepaid return of the equipment claimed to be defective to an authorized Graco distributor for verification of the claimed defect. If the claimed defect is verified, Graco will repair or replace free of charge any defective parts. The equipment will be returned to the original purchaser transportation prepaid. If inspection of the equipment does not disclose any defect in material or workmanship, repairs will be made at a reasonable charge, which charges may include the costs of parts, labor, and transportation.

THIS WARRANTY IS EXCLUSIVE, AND IS IN LIEU OF ANY OTHER WARRANTIES, EXPRESS OR IMPLIED, INCLUDING BUT NOT LIMITED TO WARRANTY OF MERCHANTABILITY OR WARRANTY OF FITNESS FOR A PARTICULAR PURPOSE.

Graco's sole obligation and buyer's sole remedy for any breach of warranty shall be as set forth above. The buyer agrees that no other remedy (including, but not limited to, incidental or consequential damages for lost profits, lost sales, injury to person or property, or any other incidental or consequential loss) shall be available. Any action for breach of warranty must be brought within two (2) years of the date of sale.

GRACO MAKES NO WARRANTY, AND DISCLAIMS ALL IMPLIED WARRANTIES OF MERCHANTABILITY AND FITNESS FOR A PARTICULAR PURPOSE, IN CONNECTION WITH ACCESSORIES, EQUIPMENT, MATERIALS OR COMPONENTS SOLD BUT NOT MANUFACTURED BY GRACO. These items sold, but not manufactured by Graco (such as electric motors, switches, hose, etc.), are subject to the warranty, if any, of their manufacturer. Graco will provide purchaser with reasonable assistance in making any claim for breach of these warranties.

In no event will Graco be liable for indirect, incidental, special or consequential damages resulting from Graco supplying equipment hereunder, or the furnishing, performance, or use of any products or other goods sold hereto, whether due to a breach of contract, breach of warranty, the negligence of Graco, or otherwise.

FOR GRACO CANADA CUSTOMERS

The Parties acknowledge that they have required that the present document, as well as all documents, notices and legal proceedings entered into, given or instituted pursuant hereto or relating directly or indirectly hereto, be drawn up in English. Les parties reconnaissent avoir convenu que la rédaction du présente document sera en Anglais, ainsi que tous documents, avis et procédures judiciaires exécutés, donnés ou intentés, à la suite de ou en rapport, directement ou indirectement, avec les procédures concernées.

Graco Information

For the latest information about Graco products, visit www.graco.com.

For patent information, see www.graco.com/patents.

TO PLACE AN ORDER, contact your Graco distributor or call to identify the nearest distributor.

Toll Free Phone Number: 1-800-328-0211

All written and visual data contained in this document reflects the latest product information available at the time of publication. Graco reserves the right to make changes at any time without notice.

Original instructions. This manual contains English. MM

Graco Headquarters: Minneapolis

International Offices: Belgium, China, Japan, Korea

GRACO INC. AND SUBSIDIARIES • P.O. BOX 1441 • MINNEAPOLIS MN 55440-1441 • USA
Copyright 2023, Graco Inc. All Graco manufacturing locations are registered to ISO 9001.

www.graco.com
Revision R, October 2024