

# Electric Direct Drive Agitators

3A4553J

EN

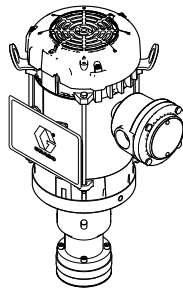
***Low shear, electric, direct drive agitator for mixing and maintaining suspension of industrial coating stored in fluid tanks. For professional use only.***

See page 3 for model information, including maximum working pressure and approvals.

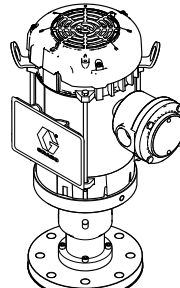


## Important Safety Instructions

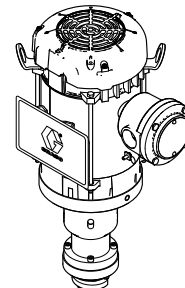
Read all warnings and instructions in this manual before using the equipment. Be familiar with the proper control and usage of the equipment. Save these instructions.



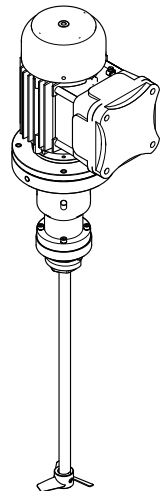
25C453  
25C575



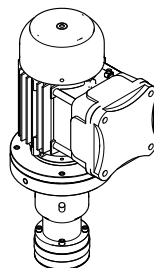
25C454



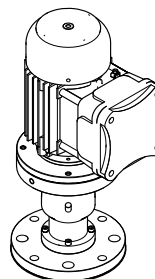
25C462  
25C470  
25C471



25C465  
25C472  
25C473



25C464  
25C576



25C463


# Contents

<b>Contents</b> .....	<b>2</b>
<b>Models</b> .....	<b>3</b>
<b>Safety Symbols</b> .....	<b>5</b>
<b>General Warnings</b> .....	<b>6</b>
<b>Installation</b> .....	<b>9</b>
Shaft and Impeller Size .....	9
VFD .....	12
Grounding the Agitator .....	13
<b>Operation</b> .....	<b>15</b>
<b>Maintenance</b> .....	<b>16</b>
<b>Service</b> .....	<b>17</b>
<b>Parts</b> .....	<b>18</b>
<b>Power Usage Charts</b> .....	<b>24</b>
<b>Dimensions</b> .....	<b>27</b>
<b>Technical Specifications</b> .....	<b>29</b>
<b>California Proposition 65</b> .....	<b>30</b>
<b>Graco Standard Warranty</b> .....	<b>31</b>

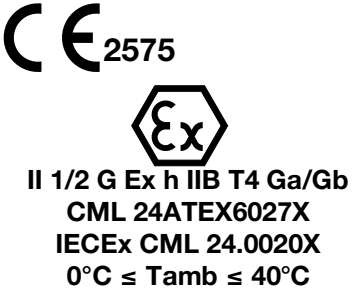
## Models

The Electric Direct Drive Agitator requires power from a variable frequency drive (VFD) to control speed and is not to be used without one. See manual 3A4793 for a listing of part numbers for related VFD controls, to be ordered separately.

### UL Listed Explosion Proof Inverter Duty Motor.

Part No.	Description	Motor Hazardous Location Approvals
25C453+	3" Quick-clamp Flange Mount Agitator Motor	
25C575+	4" Quick-clamp Flange Mount Agitator Motor	
25C454+	7.5" OD Flange Mount Agitator Motor (3" 150# ANSI Flange Mounting Holes)	
25C462*	Pressure Tank Agitator Assembly (5 Gallon)	
25C470*	Pressure Tank Agitator Assembly (10 Gallon)	
25C471*	Pressure Tank Agitator Assembly (15 Gallon)	

### ATEX Listed Explosion Proof Inverter Duty Motor

Part No.	Description	Agitator Approvals
25C464+	3" Quick-clamp Flange Mount Motor	
25C576+	4" Quick-clamp Flange Mount Motor	
25C463+	7.5" OD Flange Mount Motor (3" 150# ANSI Flange Mounting Holes)	
25C465*	Pressure Tank Agitator Assembly (5 Gallon)	
25C472*	Pressure Tank Agitator Assembly (10 Gallon)	
25C473*	Pressure Tank Agitator Assembly (15 Gallon)	

+ Does not come with shaft or impeller. See **Shaft and Impeller Size**, page 9, for proper shaft length and impeller diameter part numbers, to be ordered separately.



\* These models include a shaft and impeller, but do not include pressure tanks. These models are for the replacement of existing air motor driven pressure tank agitators. See manual 308369 for corresponding pressure tank part numbers, to be ordered separately.

### Optional Gear Reducer Kits

Optional gear reducer kits are available for both the UL and ATEX motors. See **Optional 4.8 to 1 Gear Reducer Kits**, page 10 for more information.

### Hazardous Location Approved Combinations



The following agitator assemblies are approved for hazardous locations. An approved assembly consists of one component from each column. The approved assemblies can be used with or without the gear reducer.







Part No.	Optional Gear Reducer	Shaft *	Impeller *	Combination Approvals	
25C464	25N645	17P005	17N704		
		17P006			
		17P007			
		17P008			
		17P009			
		17P010			
25C576		17P011	17N708		 <p>II 1/2 G Ex h IIB T4 Ga/Gb CML 24ATEX6027X IECEX CML 24.0020X 0°C ≤ Tamb ≤ 40°C</p>
		17P012			
		17P013			
		17P014			
		17P015			
		17P016			
25C463		17P017	17N712		
		17P018			
		17P019			
		17P020			
		17P021			
		17P022			
		17P023			

\* See Shaft and Impeller Size, page10 for shaft and impeller details.

# Safety Symbols

The following safety symbols appear throughout this manual and on warning labels. Read the table below to understand what each symbol means.

Symbol	Meaning
	Burn Hazard
	Crush Hazard
	Electric Shock Hazard
	Equipment Misuse Hazard
	Fire and Explosion Hazard
	Entanglement Hazard
	Splash Hazard

Symbol	Meaning
	Toxic Fluid or Fumes Hazard
	Ground Equipment
	Follow Pressure Relief Procedure
	Ventilate Work Area
	Wear Personal Protective Equipment
	Eliminate Ignition Sources
















## Safety Alert Symbol

This symbol indicates: Attention! Become Alert! Look for this symbol throughout the manual to indicate important safety messages.

## General Warnings

The following warnings are for the setup, use, grounding, maintenance, and repair of this equipment. The exclamation point symbol alerts you to a general warning and the hazard symbols refer to procedure-specific risks. When these symbols appear in the body of this manual, refer back to these Warnings. Product-specific hazard symbols and warnings not covered in this section may appear throughout the body of this manual where applicable.

 <b>DANGER</b>	
 	<p><b>SEVERE ELECTRIC SHOCK HAZARD</b></p> <p>This equipment uses high voltage power. Improper contact with high voltage equipment will cause death or serious injury.</p> <ul style="list-style-type: none"><li>• Turn off and disconnect power at main switch before disconnecting any cables and before servicing equipment.</li><li>• This equipment must be grounded. Connect only to grounded power source.</li><li>• All electrical wiring must be done by a qualified electrician and comply with all local codes and regulations.</li></ul>

 <h1 style="margin: 0;">WARNING</h1>	
   	<p><b>FIRE AND EXPLOSION HAZARD</b></p> <p>Flammable fumes, such as solvent and paint fumes, in <b>work area</b> can ignite or explode. Paint or solvent flowing through the equipment can cause static sparking. To help prevent fire and explosion:</p> <ul style="list-style-type: none"> <li>• Use equipment only in well ventilated area.</li> <li>• Eliminate all ignition sources; such as pilot lights, cigarettes, portable electric lamps, and plastic drop cloths (potential static arc).</li> <li>• Ground all equipment in the work area. See <b>Grounding the Agitator</b>, page 13.</li> <li>• Never spray or flush solvent at high pressure.</li> <li>• Keep work area free of debris, including solvent, rags and gasoline.</li> <li>• Do not plug or unplug power cords, or turn power or light switches on or off when flammable fumes are present.</li> <li>• Use only grounded hoses.</li> <li>• Hold gun firmly to side of grounded pail when triggering into pail. Do not use pail liners unless they are antistatic or conductive.</li> <li>• <b>Stop operation immediately</b> if static sparking occurs or you feel a shock, Do not use equipment until you identify and correct the problem.</li> <li>• Keep a working fire extinguisher in the work area.</li> </ul>
 	<p><b>EQUIPMENT MISUSE HAZARD</b></p> <p>Misuse can cause death or serious injury.</p> <ul style="list-style-type: none"> <li>• Do not operate the unit when fatigued or under the influence of drugs or alcohol.</li> <li>• Do not exceed the maximum working pressure or temperature rating of the lowest rated system component. See <b>Technical Specifications</b> in all equipment manuals.</li> <li>• Use fluids and solvents that are compatible with equipment wetted parts. See <b>Technical Specifications</b> in all equipment manuals. Read fluid and solvent manufacturer’s warnings. For complete information about your material, request SDS from distributor or retailer.</li> <li>• Do not leave the work area while equipment is energized or under pressure.</li> <li>• Check equipment daily. Repair or replace worn or damaged parts immediately with genuine manufacturer’s replacement parts only.</li> <li>• Do not alter or modify equipment. Alterations or modifications may void agency approvals and create safety hazards.</li> <li>• Make sure all equipment is rated and approved for the environment in which you are using it.</li> <li>• Use equipment only for its intended purpose. Call your distributor for information.</li> <li>• Route hoses and cables away from traffic areas, sharp edges, moving parts, and hot surfaces.</li> <li>• Do not kink or over bend hoses or use hoses to pull equipment.</li> <li>• Keep children and animals away from work area.</li> <li>• Comply with all applicable safety regulations.</li> </ul>
 	<p><b>MOVING PARTS HAZARD</b></p> <p>Moving parts can pinch, cut or amputate fingers and other body parts.</p> <ul style="list-style-type: none"> <li>• Keep clear of moving parts.</li> <li>• Do not operate equipment with protective guards or covers removed.</li> <li>• Before checking, moving, or servicing equipment, disconnect all power sources.</li> </ul>
	<p><b>TOXIC FLUID OR FUMES HAZARD</b></p> <p>Toxic fluids or fumes can cause serious injury or death if splashed in the eyes or on skin, inhaled, or swallowed.</p> <ul style="list-style-type: none"> <li>• Read Safety Data Sheet (SDS) to know the specific hazards of the fluids you are using.</li> <li>• Store hazardous fluid in approved containers, and dispose of it according to applicable guidelines.</li> </ul>



# WARNING



## **BURN HAZARD**

Equipment surfaces and fluid that is heated can become very hot during operation. To avoid severe burns:

- Do not touch hot fluid or equipment.



## **PERSONAL PROTECTIVE EQUIPMENT**

Wear appropriate protective equipment when in the work area to help prevent serious injury, including eye injury, hearing loss, inhalation of toxic fumes, and burns. Protective equipment includes but is not limited to:

- Protective eyewear and hearing protection.
- Respirators, protective clothing, and gloves as recommended by the fluid and solvent manufacturer.



# Installation

## Shaft and Impeller Size

Flange-mounted and quick-clamp flange mounted agitators need shafts and blades. See below to determine the length of the shaft and the recommended impeller diameter.

### Recommended Impeller Diameter\*

Impeller Kit Number	Inside Tank Diameter "T"	Stainless Steel Impeller Diameter "D"
17N704	12" (30 cm) or less	4" (10 cm)
17N708	12" (30 cm) to 22" (56 cm)	8" (20 cm)
17N712	22" to 36" (56 to 91.5 cm)	12" (30 cm)**

\*Recommended impeller blade diameter is generally determined by taking the inside dimension of the tank, drum, or vessel (T in FIG. 1) and multiplying by 0.35.

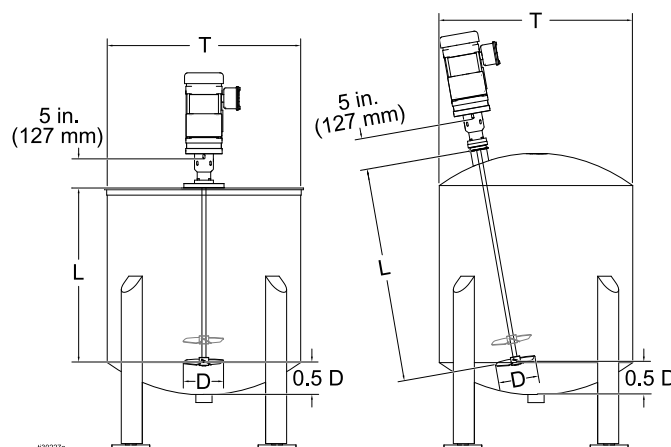
\*\*Speed is limited by material viscosity and tank diameter for 12" (30 cm) impeller. See **Finding the Proper Agitator Speed**, page 15.

To determine the shaft length ("A" in **Recommended Impeller Diameter\***):

1. Find the distance from the bottom of the tank up 1/2 the impeller diameter (i.e., 2", 4", or 6") (See 0.5 D in FIG. 1).
2. From that point, measure to the lid mounting surface (L).
3. Add measurement in step 2 (L) to the length of the bearing housing (5" or 127 mm).

Example: Shaft length "A" = L + 5 inches (127 mm).

**NOTE:** Round each measurement up or down to nearest shaft length in Table **Recommended Impeller Diameter\***.



**FIG. 1: Measure for Shaft Length**

### Shaft Length Part Numbers




Shaft Part No.	Length "A" in (cm)
17P005	54 (137)
17P006	52 (132)
17P007	50 (127)
17P008	48 (122)
17P009	46 (117)
17P010	44 (112)
17P011	42 (107)
17P012	40 (101)
17P013	38 (97)
17P014	36 (91)
17P015	34 (86)
17P016	32 (81)
17P017	30 (76)
17P018	28 (71)
17P019	26 (66)
17P020	24 (61)
17P021	22 (56)
17P022	20 (51)
17P023	18 (46 cm)

### Optional 4.8 to 1 Gear Reducer Kits

- Use Kit 25N644 for mounting onto UL listed motor assemblies (see **UL Listed Explosion Proof Inverter Duty Motor.**, page 3).
- Use Kit 25N645 for mounting onto ATEX listed motor assemblies (see **ATEX Listed Explosion Proof Inverter Duty Motor**, page 3).

Kits include the gear reducer and mounting hardware. To install and mount the gear reducer, see **Gear Reducer Kit Installation**, page 13.

### Motor, Bearing Housing, and Impeller Installation

				
<p>All electrical wiring must be done by a qualified electrician and comply with all local codes and regulations. Only trained and qualified personnel who have read and who understand the information in this manual should install this equipment.</p> <p>Always maintain a minimum of 1 in. (25.4 mm) clearance between rotating agitator parts and container to prevent sparks from contact.</p> <p>Personal injury or equipment damage may result from lifting/falling heavy equipment. To avoid personal injury or equipment damage:</p> <ul style="list-style-type: none"> <li>• Do not lift the drum cover and agitator without proper assistance.</li> <li>• Do not walk or stand beneath a raised elevator.</li> </ul>				

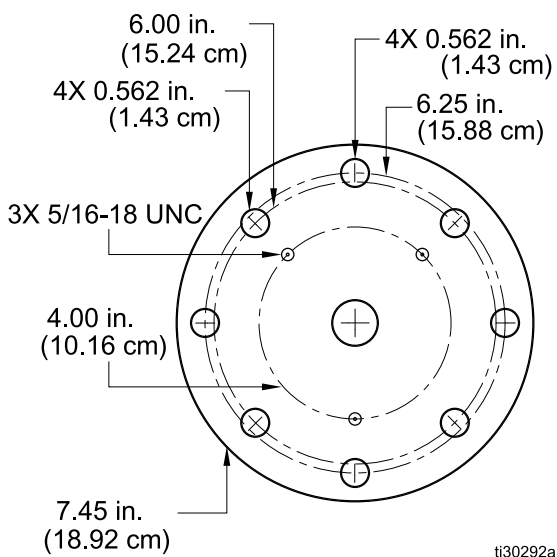
For best results, do not remove any protective wrappings from any of the agitator parts until just prior to assembly and installation. Store all parts indoors, in clean dry air.

FIG. 2 shows the holes for installing agitator flanges (part numbers 25C454 and 25C453) to the mounting surface. Holes required in the mounting surface are:

**Shaft hole:** 1" - 2" (2.54 cm - 5.08 cm)

**Mounting the flange (3 methods):**

- (3) holes to mount to Graco drum lids that have mounting surface for back-gear agitator housings.
- (4) holes for 3" 150# ANSI flange pattern (6" diameter bolt circle). This pattern is for new installations.
- (4) holes for mounting to an existing Graco LSA supplied agitator mounting pattern (6.25" diameter bolt circle).



**Fig. 2: Agitator Mounting Hole Dimensions**

Motor and bearing housing weigh approximately 50 lbs (22.6 kg). Verify that adequate personnel are available or a secure lifting device is available for use in positioning and installing.

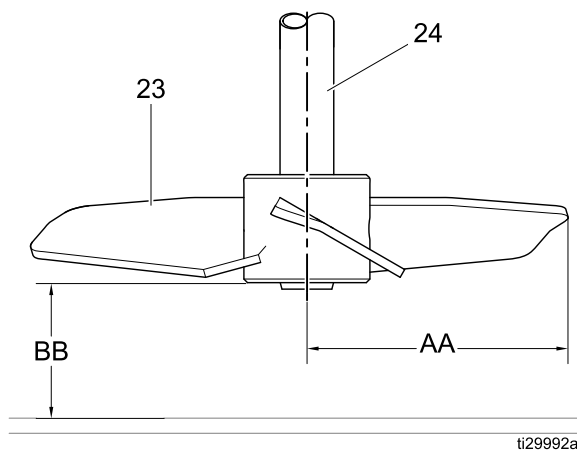
**NOTE:** Eye bolts (26) are shipped loose to be attached for lifting the agitator. See attachment location (**Parts**, page 18).

1. Install bearing housing/flange assembly per the following:
  - a. For flange mount: See **Models 25C454 and 25C463**, page 18 for parts identification. Place gasket (20) and bearing housing/flange assembly (A) on tank cover. Install flat washers, mounting bolts, and nuts (not provided). Tighten securely.
  - b. For quick-clamp flange mount: See **Models 25C453, 25C575, 25C464, 25C576**, page 20

for parts identification. Place bearing housing/flange assembly (A) on top of quick-clamp gasket (not provided) and existing quick-clamp flange on tank. Attach with clamp (not provided) and tighten securely.

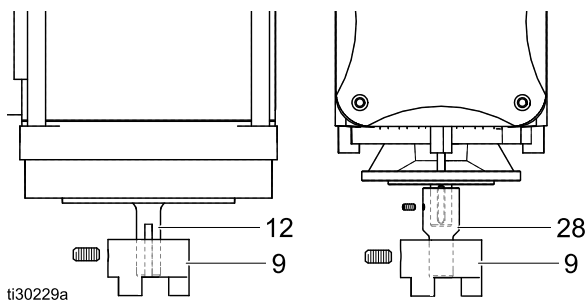
- c. For pressure tank: See **Models 25C462, 25C470, 25C471, 25C465, 25C472, 25C473**, page 22 for parts identification. Place gasket (21) and bearing housing/flange assembly (A) on pressure tank cover. Install and secure with lock washer (32) and nut (22). Tighten securely to prevent assembly from rotating.

2. Install the retaining ring (6) in the machined slot in the agitator shaft (24).
3. Slide shaft through the bearing housing/flange assembly from the top side of the bearing housing until the retaining ring rests on the upper bearing.
4. Slide the impeller (23) (see FIG. 3) onto the shaft (24) so the blade is pushing material down with the blade turning clockwise when viewed from above. Shaft can be moved up and down in the bearing housing to install the impeller.
5. Position the impeller along the shaft as required: The distance from the tank bottom to the lowest impeller blade (BB) should be 1/2 to 1-1/2 times the impeller blade diameter (blade diameter is determined by measuring the distance from the tip of the impeller to the shaft center (AA) and multiplying by two).



**FIG. 3: Impeller Installation**

6. Secure the impeller by tightening the set screws (23a). See **Parts**, page 18.
7. Place coupling (7) onto agitator shaft above the retaining ring and tighten set screw (7a) securely.
8. Place spider disk coupling (8) on top.
9. For UL motors: Fasten motor flange (10) to bearing housing with 4 cap screws (5). For ATEX motors: Place the adapter (28) on the motor shaft and secure with set screw (29). Attach the adapter flange (30) to the motor (12) with 4 socket head cap screws (31).
10. For UL motors: Place coupling (9) flush to the bottom of the motor shaft. See FIG. 4, left side. Securely tighten set screw in coupling. For ATEX motors: Place coupling (9) flush to the bottom of the adapter (28). See FIG. 4, right side.



**FIG. 4: Coupling on Motor Shaft**

11. Place motor on motor flange (10) and secure with 4 cap screws (13). Rotate motor to desired location based on the electrical connection. If motor is to be removed often, motor can be secured to the motor flange with the supplied wing screws (labeled as 13 in parts list).

## VFD

See the VFD manufacturer’s manual for information on installation and operation of the VFD.

For a Graco supplied VFD, see manual 3A4793 for information on VFD installation and operation.

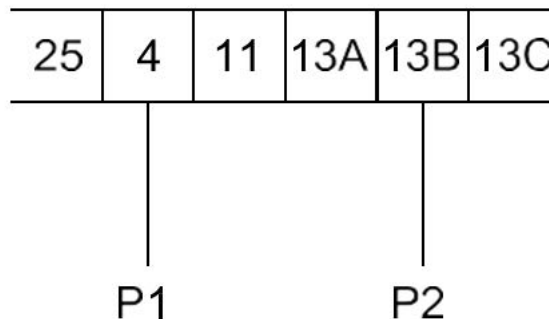
## Connect VFD to Motor

<b>NOTICE</b>
To avoid equipment damage, do not plug the motor directly into a wall socket. The motor must be wired to a VFD.

Follow the instructions in the motor manufacturer’s manual provided with this agitator to connect the VFD to the motor. Wire size, fuse size, and other electrical devices must comply with all local codes and regulations.

Motors are equipped with an automatic thermal protective device. Review the warning label on the motor stating the requirement for connecting to the control circuit terminals of the VFD. UL and NEC require connection of motor thermostat leads P1 and P2 into the control portion of a manual reset start circuit.

For Graco supplied VFDs, motor thermostat leads P1 and P2 connect to terminals 4 and 13B on the VFD, as shown below.

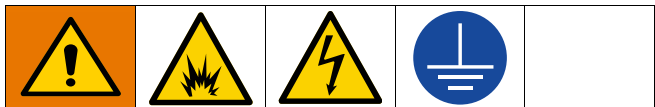


**FIG. 5: MOTOR THERMOSTAT LEADS**

For ATEX motors, follow the thermal protection wiring requirements described in the ATEX motor manual. The ATEX motor manual is included with the agitator.

For Non-Graco supplied VFD — see the motor Installation manual for instructions to connect to the VFD.

## Grounding the Agitator

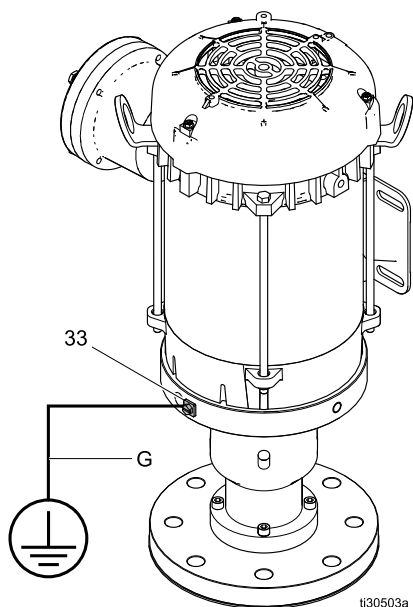


The equipment must be grounded to reduce the risk of static sparking and electric shock. Electric or static sparking can cause fumes to ignite or explode. Improper grounding can cause electric shock. Grounding provides an escape wire for the electric current.

The drum cover and all electrically conductive objects or devices in the dispensing area must be properly grounded. Check your local electrical code for detailed grounding instructions for your area and type of equipment.

**To ground the agitator**, connect one end of the ground wire (G) to the ground connector on the agitator (33). Connect the other end of the ground wire to a true earth ground.

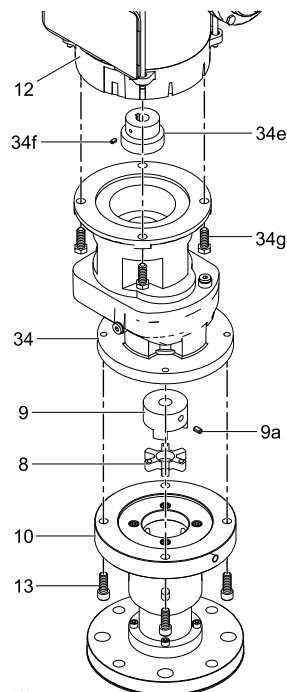
**NOTE:** Ground wire is not supplied. *To order separately, use part number 237569, Wire Assembly, 25 FT.*



**FIG. 6: Agitator Ground Wire**

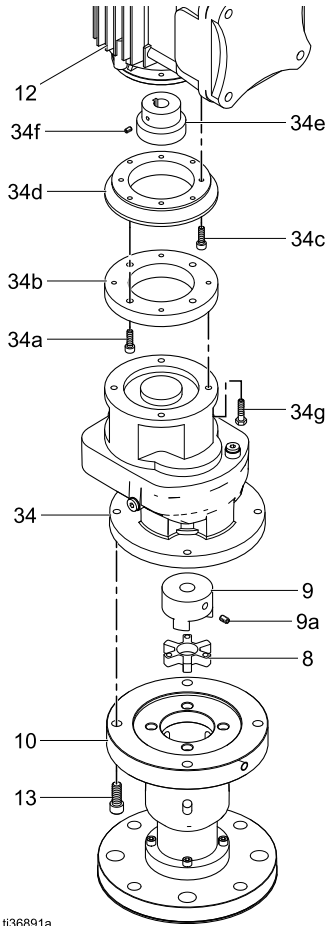
## Gear Reducer Kit Installation

The following figures illustrate how to install the gear reducer kits onto UL and ATEX listed motor assemblies.



**FIG. 7: Mounting Kit 25N644 onto UL Motor and Bearing Housing Assembly**

Ref No.	Part No.	Description	Qty
8	—	DISK, SPIDER, HYTREL ALIGNMENT	1
9	—	COUPLING, ALIGNMENT, 0.62" BORE DIAMETER	1
9a	—	SCREW, SET	1
10	—	FLANGE, MOUNT, MOTOR	1
12	—	MOTOR, UL Listed; 3/4, 230/460, TEFC, XP, 60 HZ (model 25C454)	1
	—	MOTOR, ATEX; 0.37 kW, 230/400, TEFC, XP, 50 HZ (model 25C463)	1
13	—	SCREW, CAP, SOCKET HEAD; 3/8-16 x 1"	4
	—	SCREW, WING; 3/8-16 x 1.5" (Not Shown)	4



Ref No.	Part No.	Description	Qty
34	25N644 25N645	FLANGE, MOUNT, OUTPUT	1
34a	—	SCREW, SOCKET HEAD CAP	4
34b	—	FLANGE, SPACER	1
34c	—	SCREW, SOCKET HEAD CAP	4
34d	—	FLANGE, ADAPTER	1
34e	—	COLLAR	1
34f	—	SCREW, SET	1
34g	—	SCREW, CAP	4

**FIG. 8: Mounting Kit 25N645 onto ATEX Motor and Bearing Housing Assembly**

# Operation



To reduce the risk of serious injury, including cuts, amputation of fingers by the agitator blades, and splashing in the eyes or on the skin, always power off and disconnect power to the VFD before raising, checking, or repairing the agitator.

Equipment surfaces and fluid that is heated can become very hot during operation, resulting in severe burns. To avoid severe burns do not touch hot fluid or equipment.

## General Operation

Use the VFD to start, stop, and adjust the agitator speed. See the VFD manufacturer’s manual for operating information. For a Graco supplied VFD, see manual 3A4793 for operating information.

Agitators are used to maintain solids in suspension. If solids have settled in the container, use a shaker or some other device to bring product back in suspension before installing and operating the agitator.

Activate the agitator to mix fluid thoroughly before supplying fluid to the dispensing equipment. Continue mixing fluid while the dispensing equipment is being supplied.

**NOTE:** Always use moderate agitation speeds. Excessive agitator speed may cause vibration, foaming of fluid, and increased wear on parts.

## Finding the Proper Agitator Speed

1. Fill the fluid supply container to about 3 or 4 inches (75 to 100 mm) above the agitator blade.
2. Start the agitator and gradually increase the speed until a vortex begins to form in the fluid.

3. Reduce the speed slightly, then fill the fluid container.

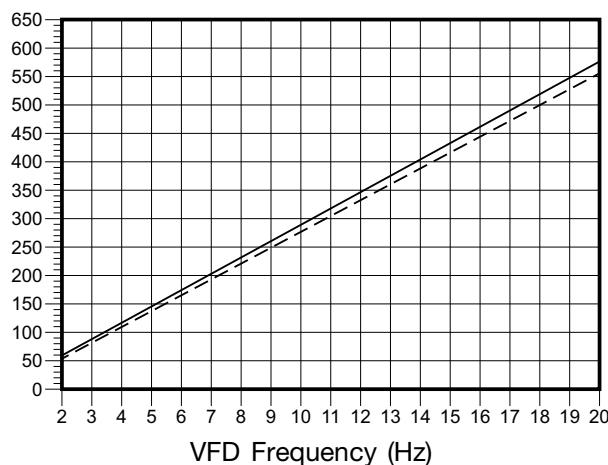
**NOTE:** Speed is limited to approximately 300 rpm for the 12” (30 cm) impeller.

If using a Graco supplied VFD, the agitator speed can be calculated by using the formula below, or determined by the graph below using the VFD frequency.

Example 1: (AIB) x C = D	
Example 2: (10 hz / 60 hz) x 1725 rpm = 292 rpm	
A	VFD Frequency
B	Motor Frequency
C	Motor Speed
D	Agitator RPM




**NOTE:** Divide agitator speed by 5 when agitator installation contains the optional gear reducer.

Agitator Shaft Speed



**FIG. 9: — UL Motor Agitator Shaft Speed – – – ATEX Motor Agitator Shaft speed**

# Maintenance

				
<p>Moving parts, such as an impeller blade, can pinch or amputate fingers. To reduce risk of injury, always power off and disconnect power from the VFD before raising, checking, or repairing the agitator.</p>				

## Routine Periodic Maintenance

Check and retighten all cap screws every six months or during down times if they occur more frequently.

## Check Screw and Bolt Tightness

Within the first two weeks of operation, check all cap screws and set screws to make sure the screws are tightened. Retighten as required.

## Bearings





Bearings are sealed and do not require lubrication. Inspect yearly to verify bearings are running smoothly and not damaged. Replace if necessary with a new bearing housing.

## Gear Reducer

The gear reducer is filled with synthetic oil and should be replaced after every 20,000 operating hours or after every four years. Consult the gear reducer manual shipped with the gear reducer for instructions on replacing the lubrication oil.



# Service

				
<ul style="list-style-type: none"> <li>• Moving parts, such as an impeller blade, can pinch or amputate fingers. To reduce risk of injury, always disconnect power from the agitator before performing maintenance or service.</li> <li>• Improper handling of hazardous fluids or inhaling toxic fumes can cause serious injury due to splashing in the eyes, ingestion, or bodily contamination.</li> </ul>				

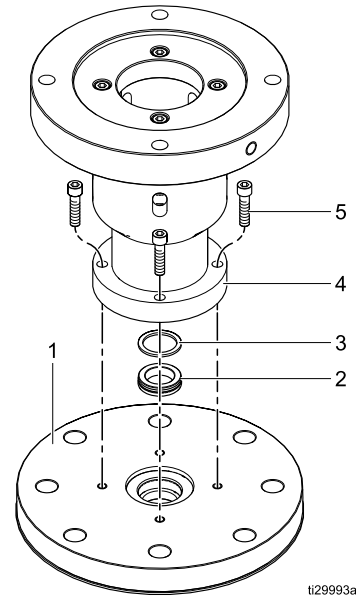
## Shaft Seal Removal and Replacement

The shaft seal (2) and spacer (3) are located at the bottom of the agitator flange (1). The shaft seal should be inspected periodically, per usage, for wear or damage, and replaced if necessary.

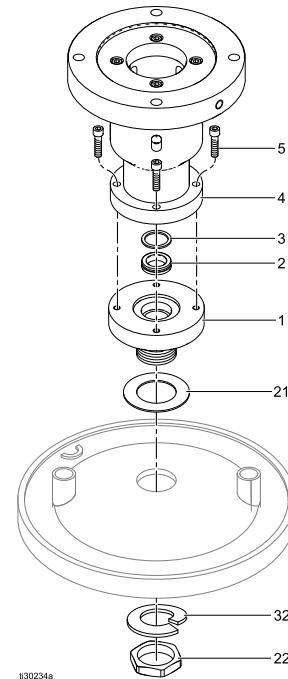
To inspect and replace the shaft seal follow the steps below.

1. Disconnect the VFD power supply.
2. Remove the motor and the agitator shaft by reversing the steps in **Motor, Bearing Housing, and Impeller Installation**, page 10.
3. Remove the cap screws (5) holding the bearing housing (4) in place.
4. Remove the bearing housing.
5. Remove the spacer (3) and shaft seal (2).
6. Inspect the seal for damage. Replace if necessary.
7. To reinstall, place the new seal spring-side down in the flange (1) with spacer on top of it.
8. Place the bearing housing on the flange and secure with the cap screws. Tighten securely.

9. Complete the procedure by following the steps in **Motor, Bearing Housing, and Impeller Installation**, page 10.



**FIG. 10: Shaft Seal Replacement for Flange/Quick-clamp Mount**



**FIG. 11: Shaft Seal Replacement for Pressure Tank**



Ref No.	Part No.	Description	Qty
A	N/A	ASSEMBLY, HOUSING/FLANGE, BEARING	1
1*	17N898	FLANGE, MOUNTING, 3" LID 150#	1
2*	17N588	SEAL, PTFE	1
3*	15Y360	SPACER, SEAL, ASME SHAFT	1
4*	25C455	HOUSING, BEARING	1
5*	112222	SCREW, CAP, SOCKET HEAD 1/4-20 x 1"	8
6	17N949	RING, RETAINING, HEAVY DUTY	1
7	122761	COUPLING, ALIGNMENT, 0.75" BORE DIAMETER	1
7a	N/A	SCREW, SET	
8	122760	DISK, SPIDER, HYTREL ALIGNMENT	1
9	16P923	COUPLING, ALIGNMENT, 0.62" BORE DIAMETER	1
9a	N/A	SCREW, SET	1
10	17N899	FLANGE, MOUNT, MOTOR	1
12	25C967	MOTOR, UL Listed 3/4, 230/460, TEFC, XP, 60 HZ (model 25C454)	1
	25C968	MOTOR, ATEX 0.37 kW, 230/400, TEFC, XP, 50 HZ (model 25C463)	1

Ref No.	Part No.	Description	Qty
13	C19837	SCREW, CAP, SOCKET HEAD 3/8-16 x 1"	4
	17P459	SCREW, WING; 3/8-16 x 1.5 " (Not Shown)	4
20	17N963	GASKET, AGITATOR 7.5" Diameter	1
23+	See Table 3	IMPELLER, 4"; KIT	1
		IMPELLER, 8"; KIT	1
		IMPELLER, 12"; KIT	1
23a	N/A	SCREW, SET	1
24+	See Table 4	SHAFT, AGITATOR	1
26	17R748	BOLT, EYE; 3/8-16 x 1.5"	2
28	17P777	ADAPTER, MOTOR, ATEX	1
29	108161	SCREW, SET, SOCKET HEAD M4 x 0.7 x 8 mm	1
30	17P776	FLANGE, MOTOR, ATEX	1
31	107530	SCREW, CAP, SOCKET HEAD M6 x 1 x 12 mm	4
33	116343	SCREW, GROUND, WASHER HEAD M5 x 8 mm	1
44▲	17R088	LABEL, WARNING	1

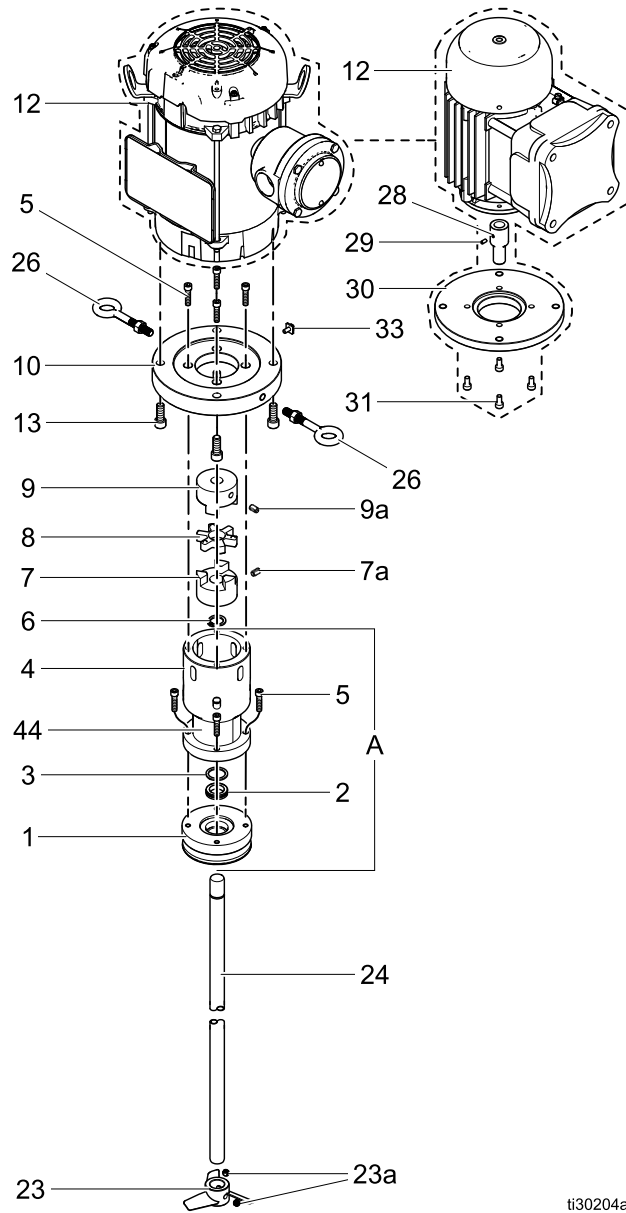
\* Part of factory-assembled item A.

+ Not included with 25C454 or 25C463. Must be ordered separately.

▲ Replacement Danger and Warning labels, signs, tags, and cards are available at no cost.

# Models 25C453, 25C575, 25C464, 25C576

## Quick-Clamp Mount



ti30204a

FIG. 13

Ref No.	Part No.	Description	Qty
A	N/A	ASSEMBLY, HOUSING/FLANGE, BEARING	1
1*	17N901	FLANGE, AGITATOR, 3" QUICK-CLAMP (models 25C453, 25C464)	1
	17P566	FLANGE, AGITATOR, 4" QUICK-CLAMP (models 25C575, 25C576)	1
2*	17N588	SEAL, PTFE	1
3*	15Y360	SPACER, SEAL, ASME SHAFT	1
4*	25C455	HOUSING, BEARING	1
5*	112222	SCREW, CAP, SOCKET HEAD 1/4-20 x 1"	8
6	17N949	RING, RETAINING, HEAVY DUTY	1
7	122761	COUPLING, ALIGNMENT, 0.75" BORE DIAMETER	1
7a	N/A	SCREW, SET	1
8	122760	DISK, SPIDER, HYTREL ALIGNMENT	1
9	16P923	COUPLING, ALIGNMENT, 0.62" BORE DIAMETER	1
9a	N/A	SCREW, SET	1
10	17N899	FLANGE, MOUNT, MOTOR	1
12	25C967	MOTOR, UL LISTED 3/4, 230/460, TEFC, XP, 60 HZ (model 25C453 and 25C575)	1
	25C968	MOTOR, ATEX 0.37 kW, 230/400 V, TEFC, XP 50 HZ (model 25C464 and 25C576)	1

13	C19837	SCREW, CAP, SOCKET HEAD 3/8-16 x 1"	4
	17P459	SCREW, WING; 3/8-16 x 1.5" (Not Shown)	4
23+	See Table 3	IMPELLER, 4"; KIT	1
		IMPELLER, 8"; KIT	1
		IMPELLER, 12"; KIT	1
23a	N/A	SCREW, SET	2
24+	See Table 4	SHAFT, AGITATOR	1
26	17R748	BOLT, EYE; 3/8-16 x 1.5"	2
28	17P777	ADAPTER, MOTOR, ATEX	1
29	108161	SCREW, SET, SOCKET HEAD M4 x 0.7 x 8 mm	1
30	17P776	FLANGE, MOTOR, ATEX	1
31	107530	SCREW, CAP, SOCKET HEAD, M6 x 1 x 12 mm	4
33	116343	SCREW, GROUND, WASHER HEAD M5 x 8 mm	1
44▲	17R088	LABEL, WARNING	1

\* Part of factory-assembled item A.

+ Not included with 25C453, 25C575, 25C464, or 25C576. Must be ordered separately.

▲ Replacement Danger and Warning labels, signs, tags, and cards are available at no cost.



Ref No.	Part No.	Description	Qty
A	N/A	ASSEMBLY, HOUSING/FLANGE, BEARING	1
1*	17N900	FLANGE, AGITATOR, PRESSURE TANK	1
2*	17N588	SEAL, PTFE	1
3*	15Y360	SPACER, SEAL, ASME SHAFT	1
4*	25C455	HOUSING, BEARING	1
5*	112222	SCREW, CAP, SOCKET HEAD 1/4-20 x 1"	8
6	17N949	RING, RETAINING, HEAVY DUTY	1
7	122761	COUPLING, ALIGNMENT, 0.75" BORE DIAMETER	1
7a	N/A	SCREW, SET	1
8	122760	DISK, SPIDER, HYTREL ALIGNMENT	1
9	16P923	COUPLING, ALIGNMENT, 0.62" BORE DIAMETER	1
9a	N/A	SCREW, SET	1
10	17N899	FLANGE, MOUNT, MOTOR	1
12	25C967	MOTOR, UL Listed 3/4, 230/460, TEFC, XP, 60 HZ (models 25C462, 25C470, 25C471)	1
	25C968	MOTOR, ATEX 3/4, 230/460, TEFC, XP, 60 HZ (models 25C465, 25C472, 25C473)	1

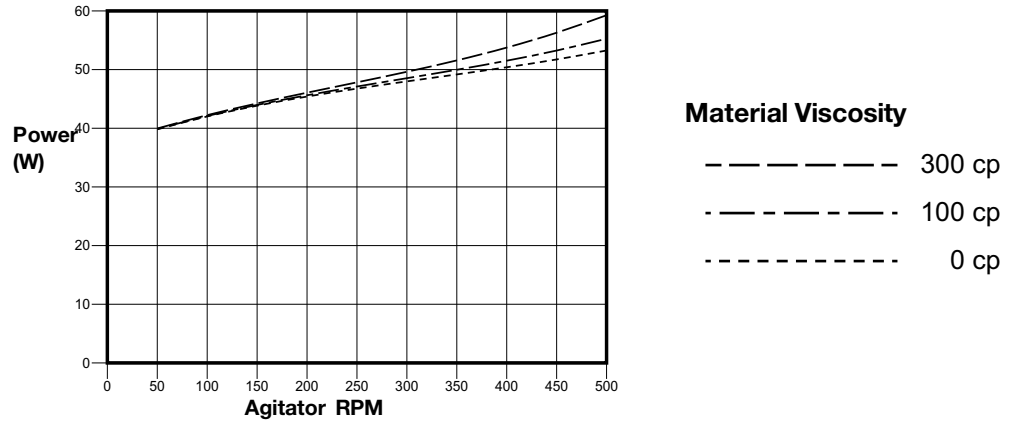
13	C19837	SCREW, CAP, SOCKET HEAD 3/8-16 x 1"	4
	17P459	SCREW, WING; 3/8-16 x 1.5" (Not Shown)	4
21	196309	GASKET	1
22	188784	NUT	1
23+	17N70 4	IMPELLER, 4"; KIT (models 25C462, 25C470, 25C465, 25C4712)	1
		IMPELLER, 4"; KIT (models 25C471, 25C473)	2
23a	N/A	SCREW, SET	1
24	17P015	SHAFT, 34" (25C471, 25C473)	1
	17P020	SHAFT, 24" (25C470, 25C472)	1
	17P023	SHAFT, 18" (25C462, 25C465)	1
26	17R748	BOLT, EYE 3/8-16x1.5"	2
28	17P777	ADAPTER, MOTOR, ATEX	1
29	108161	SCREW, SET, SOCKET HEAD M4 x 0.7 x 8 mm	1
30	17P776	FLANGE, MOTOR, ATEX	1
31	107530	SCREW, CAP, SOCKET HEAD M6 x 12 mm	4
32	17N542	WASHER, LOCK	1
33	116343	SCREW, GROUND, WASHER HEAD M5 x 8 mm	1
44▲	17R088	LABEL, WARNING	1

\* Part of factory-assembled item A.

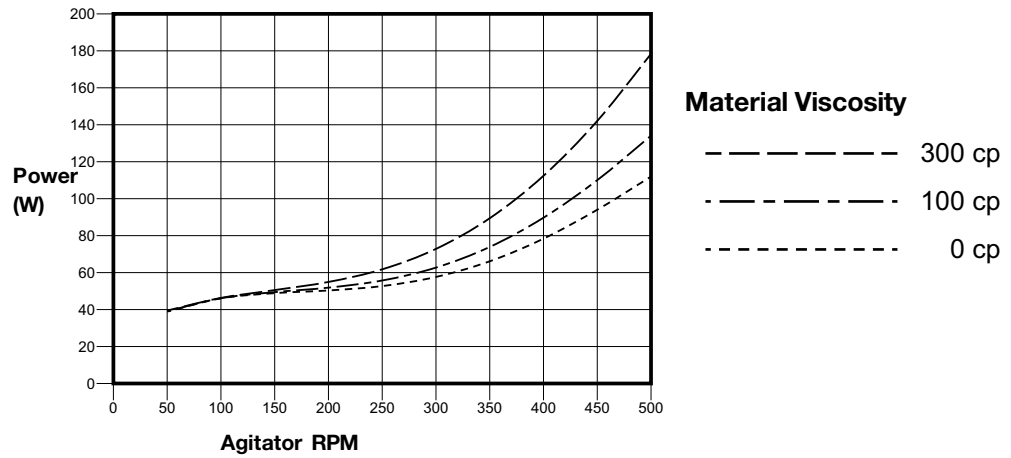
▲ Replacement Danger and Warning labels, signs, tags,  
and cards are available at no cost.

# Power Usage Charts

In the following charts, the power measured includes the VFD power usage. That power was measured with 480 VAC 3 ph line voltage with no gear reductions.

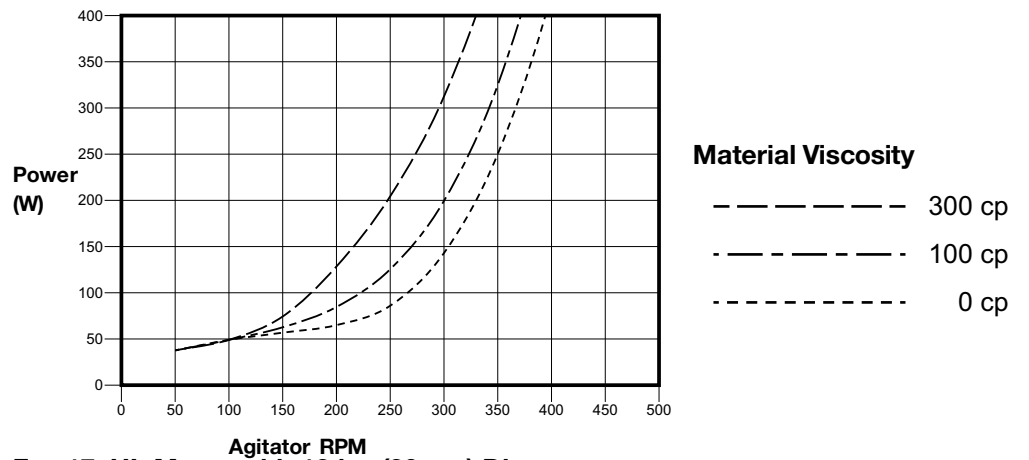


**FIG. 15: UL Motor with 4 in. (10 cm) Diameter Impeller**

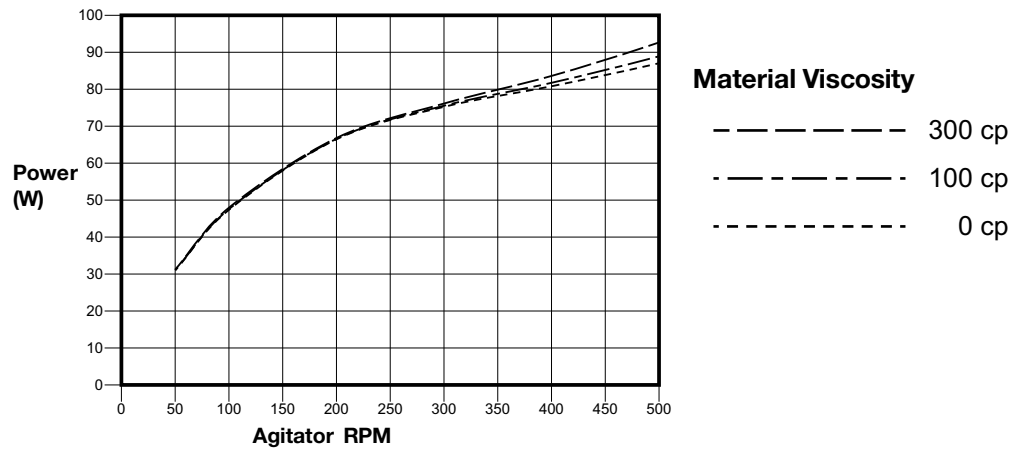


**FIG. 16: UL Motor with 8 in. (20 cm) Diameter Impeller**

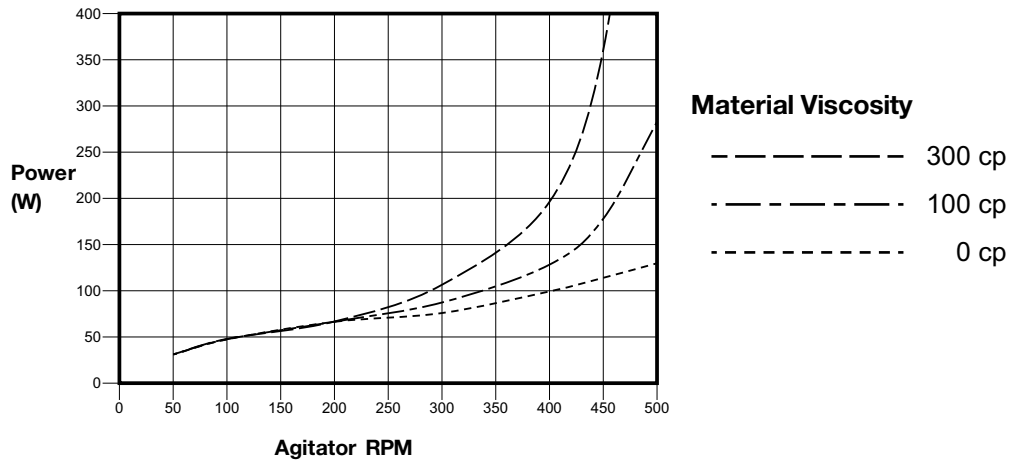




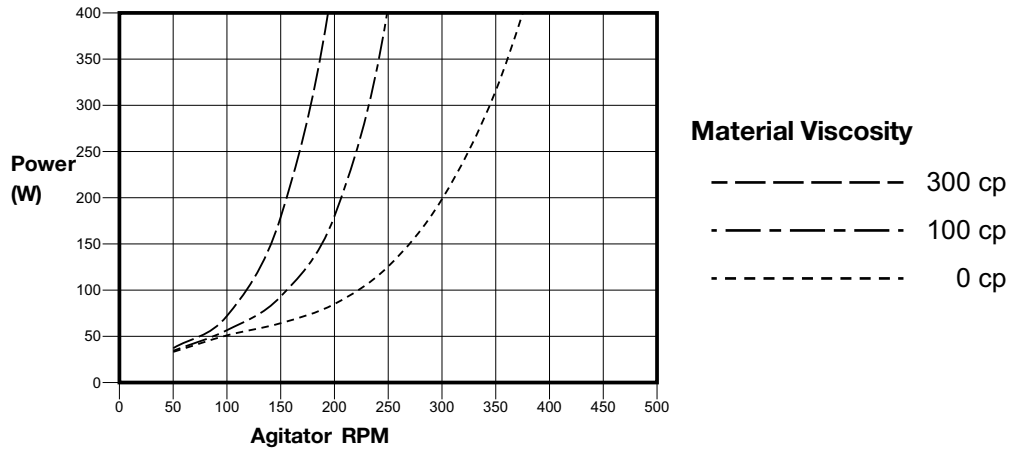
**FIG. 17: UL Motor with 12 in. (30 cm) Diameter Impeller**



**FIG. 18: ATEX Motor with 4 in. (10 cm) Diameter Impeller**

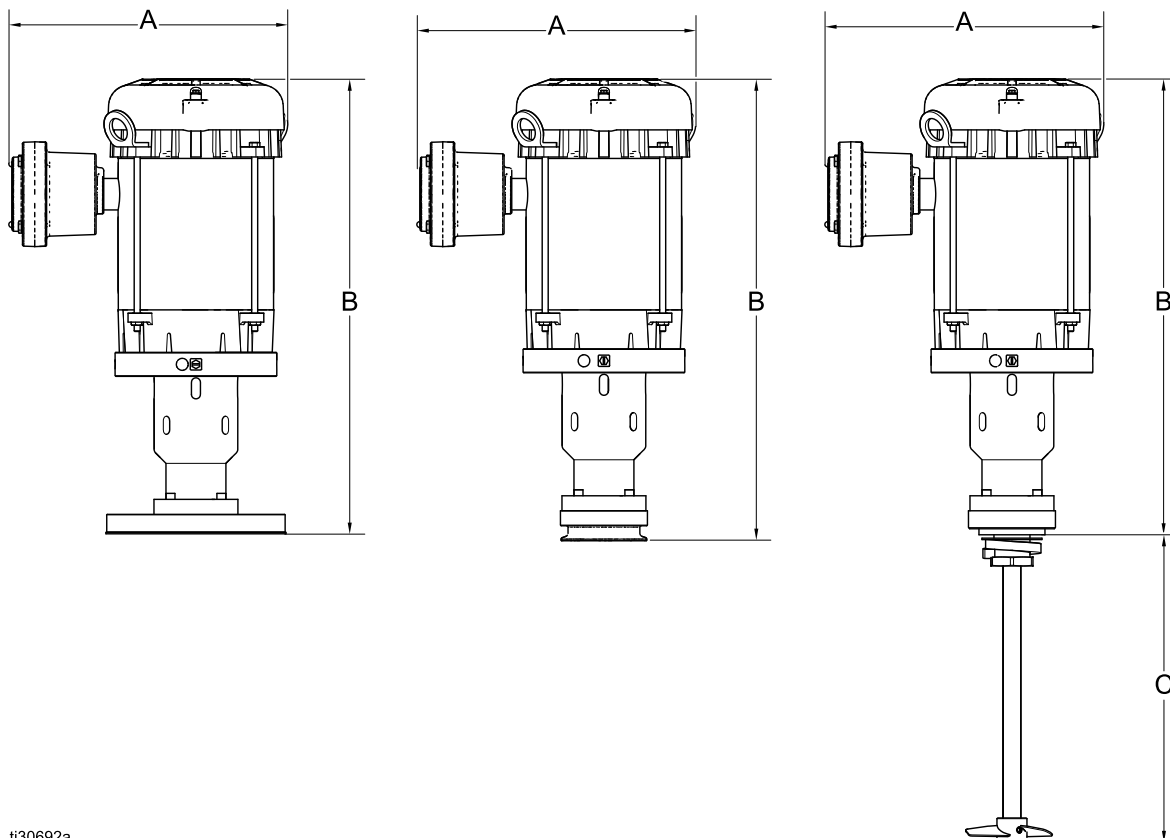


**FIG. 19: ATEX Motor with 8 in. (20 cm) Diameter Impeller**



**FIG. 20: ATEX Motor with 12 in. (30 cm) Diameter Impeller**

# Dimensions



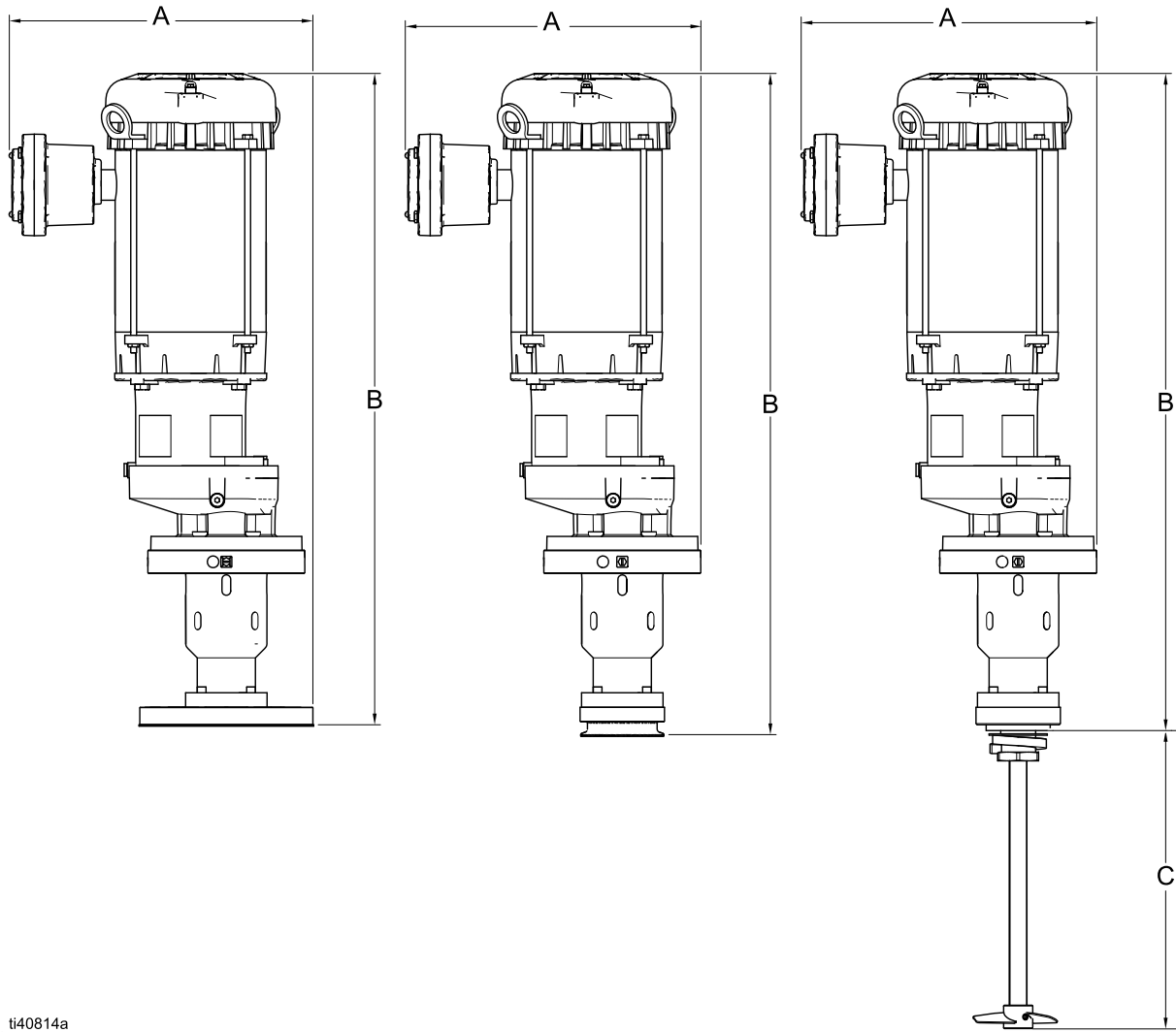
ti30692a

**FIG. 21:**

## Assemblies without Gear Reducers

Reference	Flange Mount Models in. (cm)		Quick Clamp Models in. (cm)		Pressure Tank Mount Models in. (cm)	
	UL	ATEX	UL	ATEX	UL	ATEX
	25C454	25C463	25C453, 25C575	25C464, 25C576	25C462, 25C470, 25C471	25C465, 25C472, 25C473
A	11.62 (29.5)	8.84 (22.5)	11.62 (29.5)	8.84 (22.5)	11.62 (29.5)	8.84 (22.5)
B	20.44 (51.9)	17.75 (45.1)	20.84 (52.9)	17.75 (45.1)	20.48 (52.0)	17.75 (45.1)
C	-	-	-	-	5 Gallon 12.80 (32.5)	
	-	-	-	-	10 Gallon 18.80 (47.8)	
	-	-	-	-	15 Gallon 32.80 (83.3)	

Dimensions



ti40814a  
**FIG. 22**

**Assemblies with Gear Reducers**

Reference	Flange Mount Models in. (cm)		Quick Clamp Models in. (cm)		Pressure Tank Mount Models in. (cm)	
	UL	ATEX	UL	ATEX	UL	ATEX
	25C454	25C463	25C453, 25C575	25C464, 25C576	25C462, 25C470, 25C471	25C465, 25C472, 25C473
A	13.03 (33.2)	11.37 (28.9)	12.70 (32.3)	10.99 (27.9)	12.70 (32.3)	10.99 (27.9)
B	28.04 (71.2)	24.67 (62.7)	28.48 (72.3)	25.12 (63.8)	28.23 (71.7)	24.87 (63.2)
C	-	-	-	-	5 Gallon 12.80 (32.5)	
	-	-	-	-	10 Gallon 18.80 (47.8)	
	-	-	-	-	15 Gallon 32.80 (83.3)	

# Technical Specifications

<b>Electric Direct Drive Agitators</b>	
Motor Power	UL: 3/4 hp <sup>□</sup>
	ATEX: 0.37 kW
Motor Hazardous Location Approvals	UL: Explosion Proof Class 1 Group C&D Class 2 Group F&G T3C
	ATEX/IECEX : Ex II 2G Ex d IIB T4 Gb (see declarations included with motors)
Motor Electrical Requirements	UL: 230/460 VAC, 60 Hz, 3 Phase
	ATEX/IECEX: 230/400 VAC, 50 Hz, 3 Phase
Maximum Recommended Agitator Shaft Speed	500 rpm*
Minimum Recommended Motor Speed**	2 hz, 58 rpm (UL), 2 hz, 56 rpm (ATEX/IECEX)
Weight (Motor, Bearing Housing, Shaft, Blade)	55–65 lb. (25–30 kg)
Wetted Parts	300 series SST
Maximum Allowable Process Fluid Temperature	194° F (90° C)
Recommended Maximum Material Viscosity	300 cP
Noise Data (Sound Pressure Level)	Less than 75 dBA
Ambient and Operating Temperature Range (limited by motor)	32° F to 104° F (0° C to 40° C)

\* See **Finding the Proper Agitator Speed**, page 15, for instructions on calculating agitator speed.

\*\* The minimum recommended speed is based on an operating environment temperature of 72° F (22° C). Higher environmental temperatures may require higher speeds for adequate motor cooling.

## California Proposition 65

CALIFORNIA RESIDENTS

 **WARNING:** Cancer and reproductive harm – [www.P65warnings.ca.gov](http://www.P65warnings.ca.gov).

# Graco Standard Warranty

Graco warrants all equipment referenced in this document which is manufactured by Graco and bearing its name to be free from defects in material and workmanship on the date of sale to the original purchaser for use. With the exception of any special, extended, or limited warranty published by Graco, Graco will, for a period of twelve months from the date of sale, repair or replace any part of the equipment determined by Graco to be defective. This warranty applies only when the equipment is installed, operated and maintained in accordance with Graco's written recommendations.

This warranty does not cover, and Graco shall not be liable for general wear and tear, or any malfunction, damage or wear caused by faulty installation, misapplication, abrasion, corrosion, inadequate or improper maintenance, negligence, accident, tampering, or substitution of non-Graco component parts. Nor shall Graco be liable for malfunction, damage or wear caused by the incompatibility of Graco equipment with structures, accessories, equipment or materials not supplied by Graco, or the improper design, manufacture, installation, operation or maintenance of structures, accessories, equipment or materials not supplied by Graco.

This warranty is conditioned upon the prepaid return of the equipment claimed to be defective to an authorized Graco distributor for verification of the claimed defect. If the claimed defect is verified, Graco will repair or replace free of charge any defective parts. The equipment will be returned to the original purchaser transportation prepaid. If inspection of the equipment does not disclose any defect in material or workmanship, repairs will be made at a reasonable charge, which charges may include the costs of parts, labor, and transportation.

**THIS WARRANTY IS EXCLUSIVE, AND IS IN LIEU OF ANY OTHER WARRANTIES, EXPRESS OR IMPLIED, INCLUDING BUT NOT LIMITED TO WARRANTY OF MERCHANTABILITY OR WARRANTY OF FITNESS FOR A PARTICULAR PURPOSE.**

Graco's sole obligation and buyer's sole remedy for any breach of warranty shall be as set forth above. The buyer agrees that no other remedy (including, but not limited to, incidental or consequential damages for lost profits, lost sales, injury to person or property, or any other incidental or consequential loss) shall be available. Any action for breach of warranty must be brought within two (2) years of the date of sale.

**GRACO MAKES NO WARRANTY, AND DISCLAIMS ALL IMPLIED WARRANTIES OF MERCHANTABILITY AND FITNESS FOR A PARTICULAR PURPOSE, IN CONNECTION WITH ACCESSORIES, EQUIPMENT, MATERIALS OR COMPONENTS SOLD BUT NOT MANUFACTURED BY GRACO.** These items sold, but not manufactured by Graco (such as electric motors, switches, hose, etc.), are subject to the warranty, if any, of their manufacturer. Graco will provide purchaser with reasonable assistance in making any claim for breach of these warranties.

In no event will Graco be liable for indirect, incidental, special or consequential damages resulting from Graco supplying equipment hereunder, or the furnishing, performance, or use of any products or other goods sold hereto, whether due to a breach of contract, breach of warranty, the negligence of Graco, or otherwise.

## **FOR GRACO CANADA CUSTOMERS**

The Parties acknowledge that they have required that the present document, as well as all documents, notices and legal proceedings entered into, given or instituted pursuant hereto or relating directly or indirectly hereto, be drawn up in English. Les parties reconnaissent avoir convenu que la rédaction du présente document sera en Anglais, ainsi que tous documents, avis et procédures judiciaires exécutés, donnés ou intentés, à la suite de ou en rapport, directement ou indirectement, avec les procédures concernées.

# Graco Information

For the latest information about Graco products, visit [www.graco.com](http://www.graco.com).

For patent information, see [www.graco.com/patents](http://www.graco.com/patents).

**TO PLACE AN ORDER**, contact your Graco distributor or call to identify the nearest distributor.

**Toll Free Phone Number:** 1-800-328-0211

*All written and visual data contained in this document reflects the latest product information available at the time of publication. Graco reserves the right to make changes at any time without notice.*

Original instructions. This manual contains English. MM

**Graco Headquarters:** Minneapolis

**International Offices:** Belgium, China, Japan, Korea

**GRACO INC. AND SUBSIDIARIES • P.O. BOX 1441 • MINNEAPOLIS MN 55440-1441 • USA**  
**Copyright 2023, Graco Inc. All Graco manufacturing locations are registered to ISO 9001.**

[www.graco.com](http://www.graco.com)  
Revision J, October 2024