

ProBell® Speed Controller

3A3953E
EN

For speed control of a ProBell rotary applicator as part of a paint coating system. For professional use only. Not approved for use in explosive atmospheres or hazardous locations.



Important Safety Instructions

Read all warnings and instructions in this manual and in your ProBell® Rotary Applicator manual. **Save these instructions.**

100 psi (0.7 MPa, 7.0 bar) Maximum Air Inlet Pressure

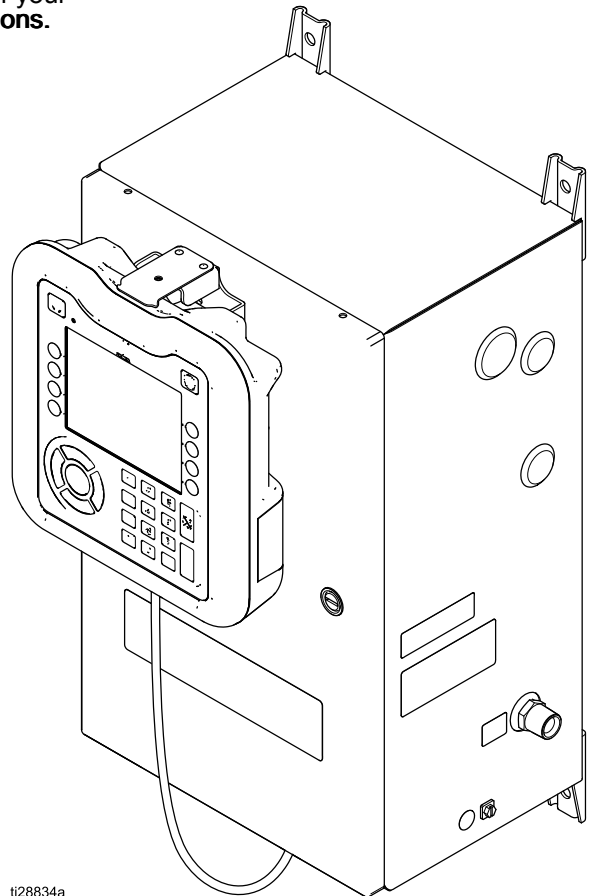

Contents

Models.....	2	Wiring the Optional Interlock Input.....	14
Related Manuals	2	Troubleshooting.....	15
Warnings	3	Repair.....	18
ProBell System Information	5	Prepare for Service	19
System Connections and Features	6	Replace the Fiber Optic Sensor	19
Component Identification.....	7	Replace A Solenoid Valve	20
Installation.....	8	Replace the Control Module.....	21
Mount the Controller.....	8	Replace the Voltage to Pressure	
Install the System Logic Controller	9	Regulator	23
Ground the Controller.....	9	Replace the Pressure Switch	24
Controller Connections.....	10	Replace the Bearing Air Filter	24
Connect Air Lines.....	11	Parts.....	25
Connect Communication Cables	11	Kits and Accessories.....	29
Connect Fiber Optic Cable.....	13	Technical Specifications.....	31
Connect Power	13	California Proposition 65	31
Set Speed Control Identity	13	Graco Standard Warranty.....	32
Wiring the System Status Output	14		

Models







Model	Description	Certification
24Z219	Includes Speed Controller, Power Supply, System Logic Controller and CAN cables.	
24Z220	Includes only the Speed Controller.	

Related Manuals

Manual in English	Description
334452	ProBell® Rotary Applicator, Instructions/Parts
334626	ProBell® Rotary Applicator, Hollow Wrist, Instructions/Parts
3A3657	ProBell® Electrostatic Controller
3A3954	ProBell® Air Controller
3A3955	ProBell® System Logic Controller
3A4384	ProBell® System CGM Installation Kit
3A4232	ProBell® Cart Systems
3A4346	ProBell® Hose Bundles Kit
3A4738	ProBell® Relective Speed Detection Kit
3A4799A	ProBell® Air Filters Kit

Warnings

The following warnings are for the setup, use, grounding, maintenance, and repair of this equipment. The exclamation point symbol alerts you to a general warning and the hazard symbols refer to procedure-specific risks. When these symbols appear in the body of this manual, refer back to these Warnings. Product-specific hazard symbols and warnings not covered in this section may appear throughout the body of this manual where applicable.

 <h2 style="margin: 0;">WARNING</h2>	
   	<p>FIRE AND EXPLOSION HAZARD</p> <p>Flammable fumes, such as solvent and paint fumes, in work area can ignite or explode. Paint or solvent flowing through the equipment can cause static sparking. To help prevent fire and explosion:</p> <ul style="list-style-type: none"> • Use equipment only in well ventilated area. • Eliminate all ignition sources; such as pilot lights, cigarettes, portable electric lamps, and plastic drop cloths (potential static sparking). • Ground all equipment in the work area. See Grounding instructions. • Never spray or flush solvent at high pressure. • Keep work area free of debris, including solvent, rags and gasoline. • Do not plug or unplug power cords, or turn power or light switches on or off when flammable fumes are present. • Use only grounded hoses. • Hold gun firmly to side of grounded pail when triggering into pail. Do not use pail liners unless they are anti-static or conductive. • Stop operation immediately if static sparking occurs or you feel a shock. Do not use equipment until you identify and correct the problem. • Keep a working fire extinguisher in the work area.
 	<p>ELECTRIC SHOCK HAZARD</p> <p>This equipment must be grounded. Improper grounding, setup, or usage of the system can cause electric shock.</p> <ul style="list-style-type: none"> • Turn off and disconnect power at main switch before disconnecting any cables and before servicing or installing equipment. • Connect only to grounded power source. • All electrical wiring must be done by a qualified electrician and comply with all local codes and regulations.



WARNING



EQUIPMENT MISUSE HAZARD

Misuse can cause death or serious injury.



- Do not operate the unit when fatigued or under the influence of drugs or alcohol.
- Do not exceed the maximum working pressure or temperature rating of the lowest rated system component. See **Technical Specifications** in all equipment manuals.
- Use fluids and solvents that are compatible with equipment wetted parts. See **Technical Specifications** in all equipment manuals. Read fluid and solvent manufacturer's warnings. For complete information about your material, request the Safety Data Sheet (SDS) from distributor or retailer.
- Turn off all equipment and follow the **Pressure Relief Procedure** when equipment is not in use.
- Check equipment daily. Repair or replace worn or damaged parts immediately with genuine manufacturer's replacement parts only.
- Do not alter or modify equipment. Alterations or modifications may void agency approvals and create safety hazards.
- Make sure all equipment is rated and approved for the environment in which you are using it.
- Use equipment only for its intended purpose. Call your distributor for information.
- Route hoses and cables away from traffic areas, sharp edges, moving parts, and hot surfaces.
- Do not kink or over bend hoses or use hoses to pull equipment.
- Keep children and animals away from work location.
- Comply with all applicable safety regulations.



PERSONAL PROTECTIVE EQUIPMENT

Wear appropriate protective equipment when in the work location to help prevent serious injury, including eye injury, hearing loss, inhalation of toxic fumes, and burns. This protective equipment includes but is not limited to:

- Protective eyewear, and hearing protection.
- Respirators, protective clothing, and gloves as recommended by the fluid and solvent manufacturer.

ProBell System Information

The ProBell Speed Controller is an optional component in the ProBell Rotary Applicator system. The Speed Controller directs the turbine air and braking air to the applicator. The controller uses a fiber optic signal from the ProBell applicator to provide precise closed-loop control of the cup rotational speed.

This manual covers information specific to the Speed Controller. It includes information on installation, troubleshooting, repair, and parts. See the ProBell Rotary Applicator manual (334452 or 334626) for all system information, including how to install and connect the whole system, required interlocks, system grounding, and required electrical tests. The applicator manual also contains all operation information. See the System Logic Controller Manual (3A3955) for details on how to set up parameters for the Speed Controller.

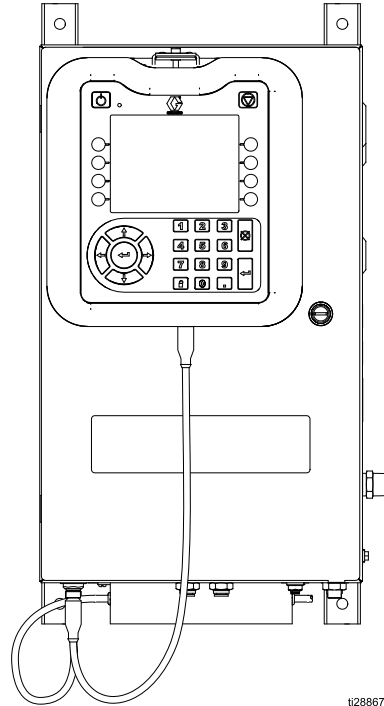











Figure 1 Speed Controller with System Logic Controller (Model 24Z219)

System Connections and Features

Air Line	Port Label	Speed Controller Connections	Electronic Air Controller Connections	Manual Air Controller Connections
B (Bearing Air)		√*		√*
BK (Braking Air)		√		
BR (Bearing Air Return)		√*		√*
DT (Dump Valve Trigger)			√	√
PT (Paint Valve Trigger)			√	√
SI (Shaping Air Inner)			√	√
SO (Shaping Air Outer)			√	√
ST (Solvent Trigger)			√	√
TA (Turbine Air)		√*		√*
Auxiliary Triggers (for system flexibility)	1, 2, 3,		√	√

* In systems with a speed controller, a bearing air, bearing air return, and turbine air must be used on the speed controller, not the manual air controller.

Component Identification

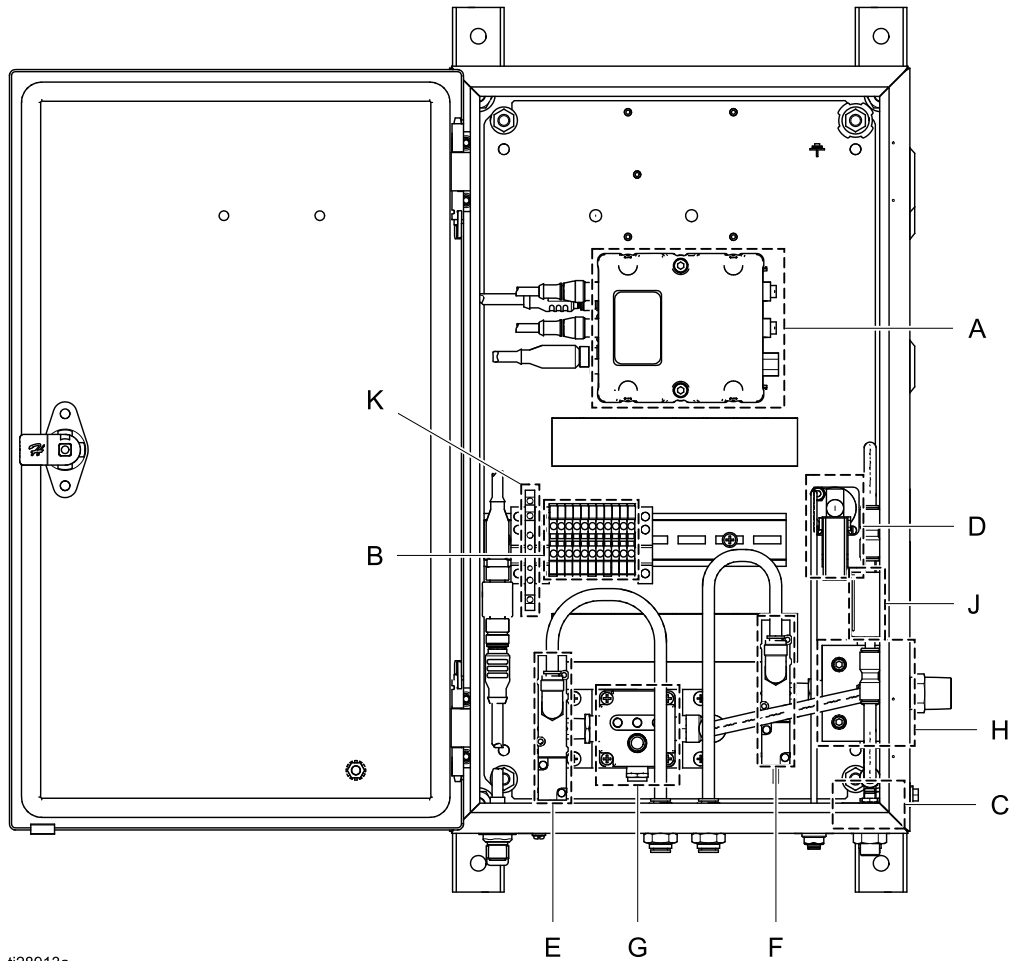



ti28913a

Ref.	Component
A	Control Module — Manages the operation of all components in the Speed Controller
B	Terminal Blocks — Provide electrical wire connections
C	Fiber Optic Sensor Module — Receives the fiber optic signal from the applicator regarding turbine speed
D	Pressure Switch — Verifies that the bearing air is at least 70 psi
E	Turbine Air Solenoid — Activates air to run the turbine
F	Brake Air Solenoid — Activates air to slow the turbine
G	Voltage to Pressure (V2P) Regulator — Converts voltage to pressure for turbine air control
H	Air Manifold — Directs incoming air to the controller components
J	Air Filter — Supplementary coalescing air filter, protects the bearing from any particles that get through the main air filtering system.
K	Optocoupler — Isolated output to communicate an error to the PLC

Installation

Mount the Controller

				
To reduce the risk of fire or explosion, do not install equipment approved only for a non-hazardous location in a hazardous location.				

Note

Install the speed controller in a non-hazardous location only.

The speed controller can be mounted on the cart or wall mounted. The box comes with four mounting brackets installed in a vertical orientation. Remove and turn the brackets if a horizontal orientation works better for your installation.

Wall Mounting

The pre-installed mounting brackets can be used to mount the controller on any flat wall. Mount the Speed Controller in the non-hazardous area, as close to the applicator as possible to minimize pressure loss in the air lines.

1. Determine the mounting location. Ensure that the wall is strong enough to support the weight of the mounting brackets and the controller. See [Technical Specifications, page 31](#).
2. See the Dimensions or use the box as a template to mark the mounting hole locations.
3. Drill holes and use four screws to attach the speed controller to the wall.

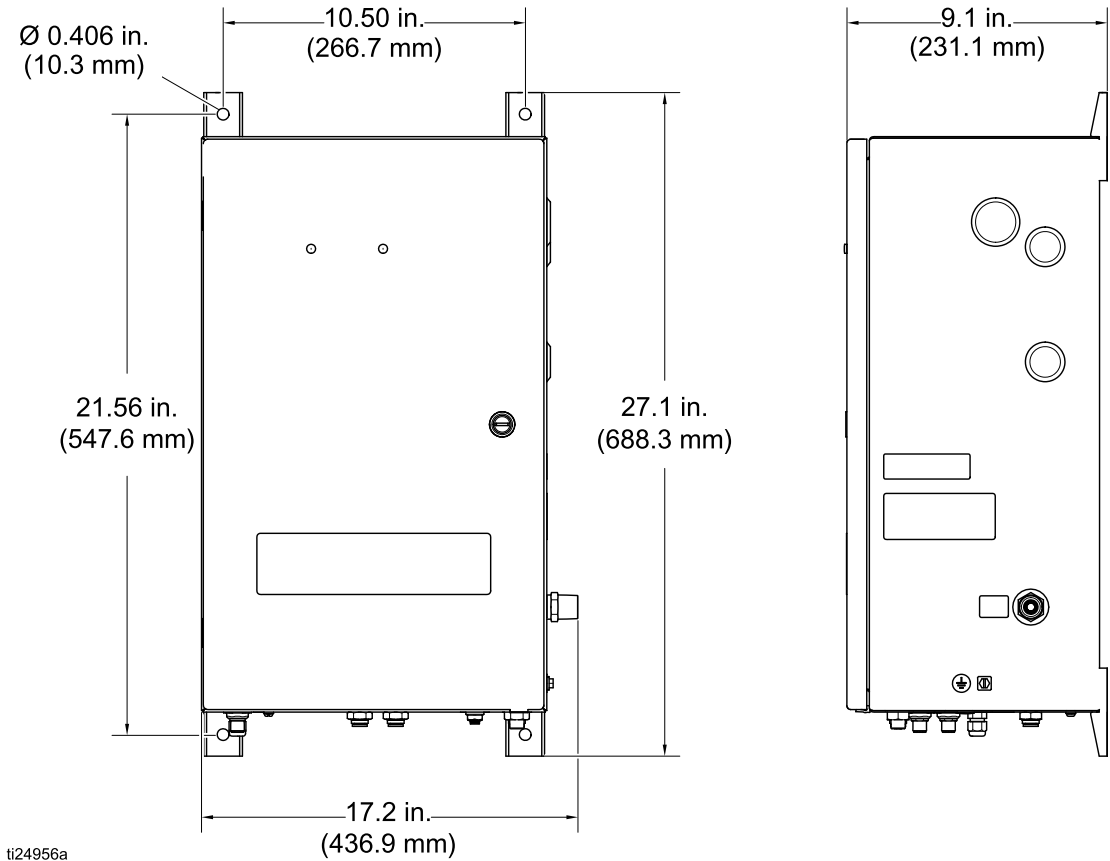

ti24956a

Cart Mounting

For some ordering options, the speed controller will be mounted on the cart at the factory. If the cart was ordered separately, use the four screws (provided) to mount the speed controller box on the cart.

Install the System Logic Controller

To protect it from damage during shipping, the System Logic Controller is packaged separately. It is already loaded with the necessary software.

1. Snap the System Logic Controller (101) into the bracket (102) on the front of the Speed Controller enclosure (1).
2. Connect a Graco CAN cable (105) from the CAN port on the System Logic Controller to another open CAN port in the control system.

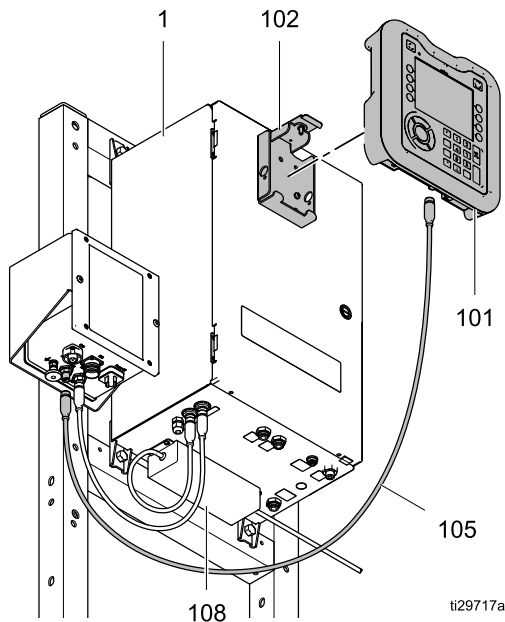

Figure 2 Model 24Z219, shown with Cart and Electrostatic Controller (both sold separately)

Ground the Controller

<p>The equipment must be grounded to reduce the risk of static sparking and electric shock. Electric or static sparking can cause fumes to ignite or explode. Improper grounding can cause electric shock. Grounding provides an escape wire for the electric current.</p>				

For full system grounding instructions and requirements, see the ProBell Rotary Applicator manual (334452 or 334626). Use the ground wire and clamp provided to ground the Speed Controller to a true earth ground.

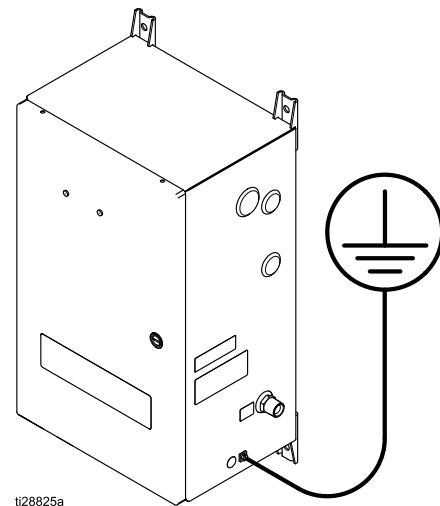
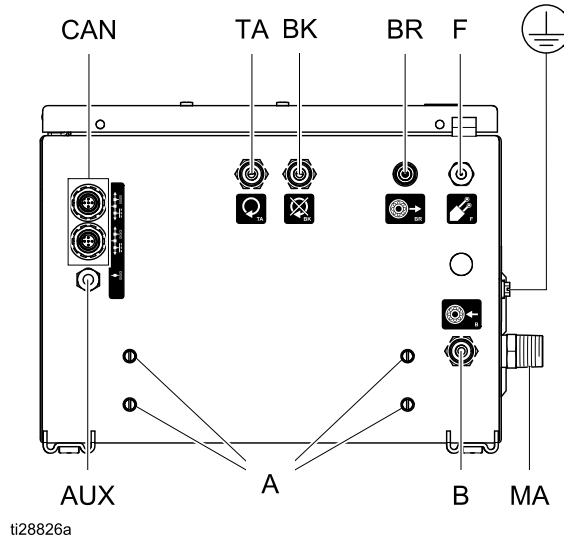

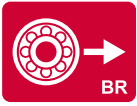

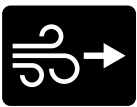



Figure 3 Ground the Controller

Controller Connections

Overview



Ref.	Port Label	Label Color	Description
A			Mounting Holes for Power Supply
B		Red	Bearing Air — Use 8 mm (5/16 in) OD tube
BK		Purple	Braking Air — Use 8 mm (5/16 in) OD tube with 1 mm (0.04 in) wall to minimize pressure drop.
BR		Red	Bearing Air Return — Use 4 mm (5/32 in.) tubing.
CAN		Black	Graco CAN / Power (24 VDC)
F		Black	Fiber Optic Speed Sensor Port
MA		Black	Main Air Port — 1/2 in. npt
TA		Brown	Turbine Air — Use 8 mm (5/16 in) OD tube with 1 mm (0.04 in) wall to minimize pressure drop.
AUX		Black	Auxiliary port for optional optocoupler wiring.

Connect Air Lines

The Graco Speed Controller is labeled with the same reference letters as the applicator, for easier matching: turbine air (TA), braking air (BK), bearing air (B), and bearing air return (BR).

NOTICE

Use filtered air to prevent contamination of the paint finish and to prevent damage to the air bearing. Air that is not adequately filtered can clog bearing air passages and cause bearing failure. The ProBell Rotary Applicator manual contains detailed filtering specifications.

Note

For the turbine air (TA), braking air (BK) and bearing air (B) lines, use 8 mm (5/16 in) OD tube with 1 mm (0.04 in) wall. For the bearing air return (BR), use 4 mm (5/32 in) tube.

NOTICE

Take great care to connect the air lines to the correct ports. Incorrect air line connections will damage the applicator.

1. Connect the air lines to the applicator first. See your applicator manual for instructions.
2. Connect the turbine air line into fitting TA, the braking air line into fitting BK, and the bearing air line into fitting B. Connect the bearing air return line into the smaller fitting BR.
3. Connect the main air supply line into the air fitting on the side of the box.

Note

Once the air is applied, it will flow freely out Port B. The controller has no option to turn this air off.

Connect Communication Cables

The speed controller communicates to the rest of the system using Graco CAN. Each component and the power supply must be on the Graco CAN network. The best connection pattern depends on whether or not the system design includes the ProBell Air Controller.

1. Connect the power supply (AA, 108) to the lower/rear Graco CAN port on the Speed Controller (EE). There must be a termination resistor Part 120999 (109) installed on the splitter inside the speed controller where the power supply is connected. This resistor is installed at the factory on Model 24Z219, but must be done by the customer on Model 24Z220.
2. Connect a Graco CAN cable (105) from the system logic controller (DD) to the Electrostatic Controller (CC) or directly to the speed controller for non-electrostatic systems.
3. Connect a Graco CAN cable from the Speed Controller (EE) to the next system component.
 - a. **Single Gun Without ProBell Air Controller:** The Graco CAN cable connects from the Speed Controller (EE) to the Electrostatic Controller (CC).

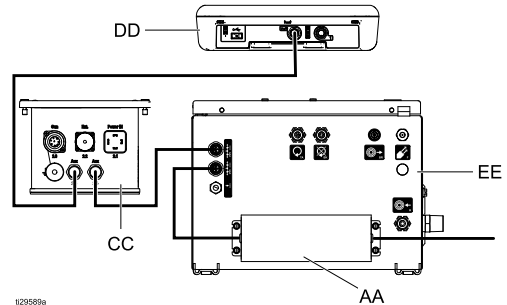

- b. **Single Gun With ProBell Air Controller:** The Graco CAN cable connects from the Speed Controller (EE) to the Air Controller (BB). An additional Graco CAN cable connects from the Air Controller (BB) to the Electrostatic Controller (CC).

Because of system variability, only one Graco CAN cable (105) comes with Model 24Z219. Other cables must be purchased at desired length to complete the installation.

Single Gun Network with ProBell Air Controller

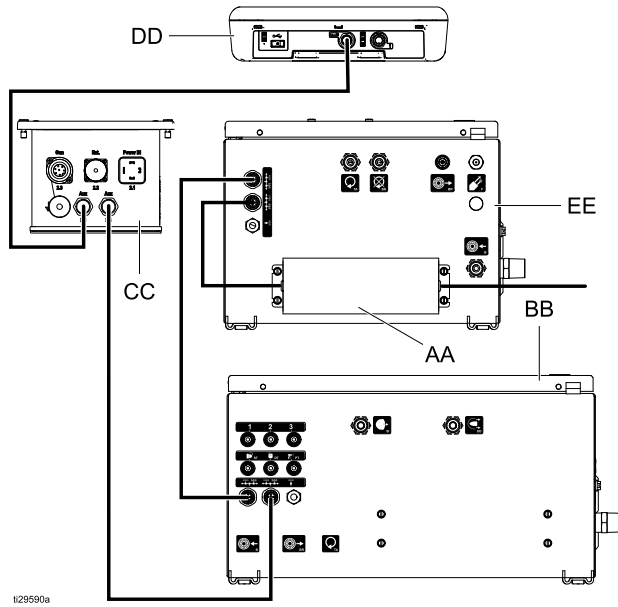

Note

For systems without an electrostatic controller (CC), connect the system logic controller directly to an open CAN port on either the speed controller (EE) or electronic air controller (BB).

Two Gun Network

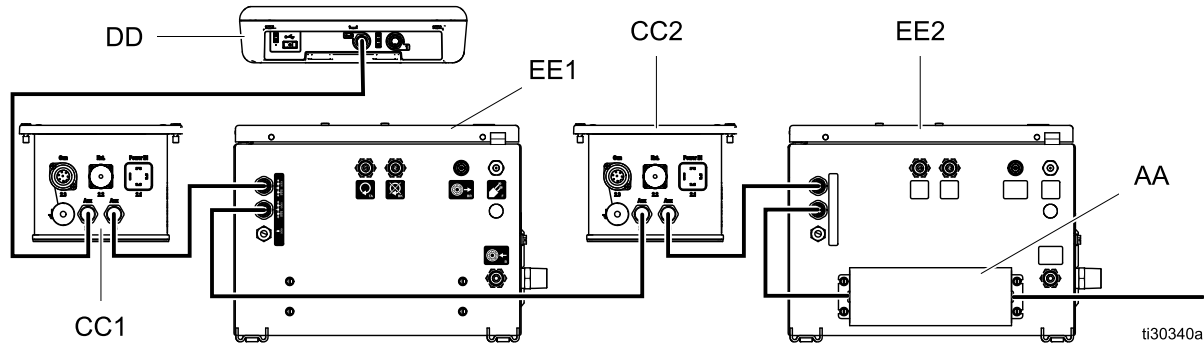

Other configurations (not shown) are possible. Follow these rules when building the CAN network.

- Connect controllers in series.
- A termination resistor must be installed on the power supply port.
- Remove all other termination resistors from the system.
- Set identities on all controllers in a two gun network.

Connect Fiber Optic Cable

The speed controller uses a fiber optic signal provided by a magnetic pickup sensor assembly in the applicator manifold. Connect the fiber optic cable from Port F on the Speed Controller to Port F on the applicator manifold. The amount of fiber extending past the nut should be 0.44 in. (11.2 mm) on the Speed Controller side. On the applicator side, the amount of extended fiber is either 0.11 in. (2.8 mm) for the standard style or 1.48 in. (37.6 mm) for the hollow wrist style. See the detailed instructions in your ProBell Applicator manual, especially if you need to cut or repair the cable, so the dimensions at each end remain accurate.

Connect Power

One power supply is required in the CAN network, typically mounted on the bottom of the Speed Controller or the Air Controller.

1. Connect a power cord to the power supply connector. A cord (106) suitable for use in North America is provided with the power supply. The power supply is included in Model 24Z219, but sold separately from Model 24Z220.
2. Connect the other end of the cord to AC power. See [Technical Specifications, page 31](#).

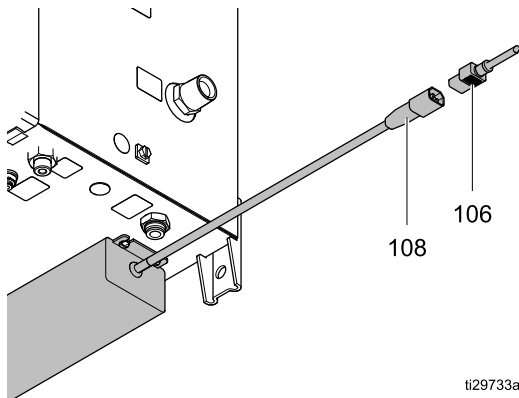

ti29733a

Set Speed Control Identity

The speed controller comes preset from the factory to control one applicator. In two-applicator systems, the identity of the control module must be set in order to communicate with the system logic controller properly.

1. Remove plug to access control module rotary switch by pushing from the inside of the box with a screwdriver.
2. Using a screwdriver, set the control module rotary switch to "1" for the speed controller that controls the second applicator.

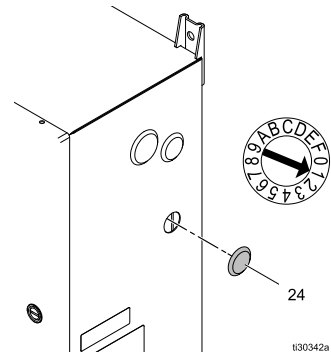

ti30342a

3. Replace the plug.
4. Restart the system by removing and reapplying power.

Wiring the System Status Output

The System Status Output provides a means to signal connected devices that the turbine is spinning.

The System Status Output is active when the system is in Gun Off mode. The System Status Output is inactive in all other operation modes. See the System Logic Controller manual (3A3955) for more information on operation modes.

The System Status Output uses an optocoupler to protect the Graco ProBell air control box from outside voltages.

- Optocoupler ports A1+ and A2- are wired to the control module.
- Optocoupler ports 13+ and 14 are wired to the external device or PLC.

For active-low signals/sourcing input: Connect GND to 14. Assuming the input signal is at non ground, monitor when 13+ is connected to GND to tell when the System Status output is active.

For active-high signals/sinking input: Connect 24 VDC to 13+. Monitor when 14 is connected to 24 VDC to tell when the System Status Output is active.

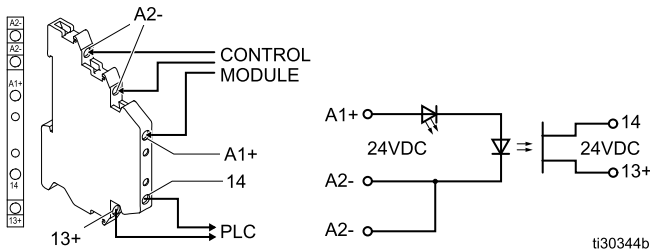

Function	A1+ (relative to A2-)	PLC
System Status Output Active	24 VDC	13+ and 14 connected
System Status Output Inactive	Less than 13.5 VDC	13+ and 14 not connected

Wiring the Optional Interlock Input

The Optional Interlock Input provides a means to signal the System Logic Controller to stop the ProBell system. This normally open contact turns the applicator off when activated. If the ProBell speed controller reads the input as CLOSED it interrupts system operation and puts the gun into Gun Off mode. If the input is read as OPEN, the system operates normally.

The optional interlock optocoupler does not come pre-installed and must be purchased and installed separately. Install kit 24Z226 to use the Optional Interlock Input.

Remove the wires in the existing terminal blocks and install in the Optocoupler ports as shown below.

	Speed Controller Terminal
Optocoupler Port 14	7
Optocoupler Port 13+	8

NOTICE

To prevent damage to equipment, do not use these terminal blocks without an optocoupler present.

The Optional Interlock Input uses an optocoupler to protect the Graco ProBell air control box from outside voltages.

- Optocoupler ports 13+ and 14 are wired to the control module.
- Optocoupler ports A1+ and A2- are wired to the external device or PLC.

Apply the 24 VDC signal to A1+ and GND to A2-. Only one A2- port needs to be connected to GND, as the two ports labeled A2- are connected internally.

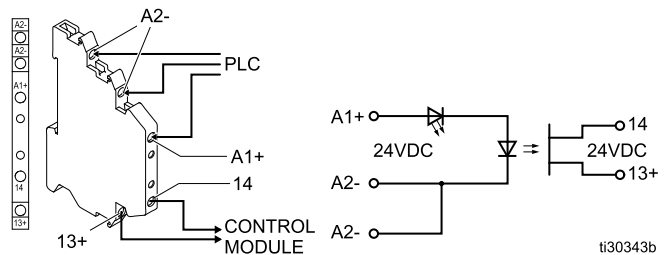

A1+ (relative to A2-)	Function
24 VDC	Interlock Activated (system stop)
Less than 13.5 VDC	Interlock Inactive (system run)

Troubleshooting

- For the paired Error codes, those that end in a 1 indicate a problem with Gun 1. Those that end in a 2 indicate a problem with Gun 2.
- References to screens pertain to the screens on the System Logic Controller.

Table 1 Control Module LED Diagnostics

Module Status LED Signal	Diagnosis	Solution
Green on	The system is powered up.	— — —
Yellow	Internal communication is in progress.	— — —
Red solid	Hardware failure	Replace the module.
Red flashing fast	The system is uploading software.	— — —
Red flashing slow	Token error	Remove the token and upload the software token again.

Table 2 Communication Errors

Code	Event Type	Name	Description	Solution
CAD1 or CAD2	Alarm	Communication Error Speed Control	The System Logic Controller does not see the Speed Controller.	<ul style="list-style-type: none"> • Verify Graco CAN connection on bottom of Speed Controller. • Check status LEDs on the control module. • Cycle power.
CA00	Alarm	Communication Error Logic Controller	System Logic Controller communication is intermittent.	Verify Graco CAN connections on the System Logic Controller are making contact..
CDD1 or CDD2	Alarm	Duplicate Speed Controller	The System Logic Controller sees two or more Speed Controllers set to the same gun.	<ul style="list-style-type: none"> • The speed controller has the same CAN ID as another module. • Adjust the selector switch on the FCM. See Set Speed Control Identity, page 13 for instructions.

Table 3 Speed Errors

Code	Event Type	Name	Description	Remedy
K1D1 or K1D2	Alarm	Speed Low Alarm	Actual turbine speed is lower than the alarm limit for longer than the alarm time (as set on Gun Screen 4).	<ul style="list-style-type: none"> • Verify inlet air pressure and flow is sufficient. • Check turbine air hose on the Speed Controller is not pinched. • Increase the alarm or deviation time.
K2D-1or K2D2	Deviation	Speed Low Deviation	Actual turbine speed is lower than the deviation limit for longer than the deviation time (as set on Gun Screen 4).	
K3D1 or K3D2	Deviation	Speed High Deviation	Actual turbine speed is higher than the deviation limit for longer than the deviation time (as set on Gun Screen 4).	<ul style="list-style-type: none"> • Verify that the voltage to pressure regulator in the Speed Controller is working properly • Verify that the brake solenoid is operating properly. • Increase the alarm or deviation time
K4D1 or K4D2	Alarm	Speed High Alarm	Actual turbine speed is higher than the alarm limit for longer than the alarm time (as set on Gun Screen 4) or speed has exceeded 65k RPM.	
K5D1 or K5D2	Alarm	Speed Controller Calibration	When calibrating turbine voltage to pressure feedback voltage, the control module detects a fault in the voltage.	<ul style="list-style-type: none"> • Relieve the inlet air pressure on speed control enclosure. Retry Calibration. • Verify cable connection between voltage to pressure regulator and connector 6 on speed control on FCM. Retry calibration. • Replace cable 17K902. • Replace voltage to pressure regulator.
K6D1 or K6D2	Alarm	Turbine V2P Feedback Error	System cannot detect feedback from turbine V2P.	
K7P1 or K7P2	Alarm	Speed Control Pressure Unknown	Manual air controls only. The system cannot determine the pressure switch state.	<ul style="list-style-type: none"> • Verify wiring on the pressure switch.
K8D1 or K8D2	Alarm	Speed Control Feedback	Turbine speed feedback was not detected	<ul style="list-style-type: none"> • Verify Fiber Optic connection on speed control box. • Verify Fiber Optic connection on applicator. • Confirm ends of the fiber optic cable are in good shape.

Table 4 Solenoid Errors

Code	Event Type	Name	Description	Remedy
WJ11 or WJ12	Alarm	Air Solenoid Removed	System does not detect the turbine air solenoid.	Verify wiring on terminals 1 and 2 in the Speed Controller.
WJ21 or WJ22	Alarm	Brake Solenoid Removed	System does not detect the brake air solenoid.	Verify wiring on terminals 3 and 4 in the Speed Controller.

Table 5 Pressure Switch Errors

Code	Event Type	Name	Description	Remedy
K9D1 or K9D2	Alarm	Bearing Air Pressure Switch Status Unknown	Pressure switch state cannot be determined.	<ul style="list-style-type: none"> Verify that inlet air pressure is greater than 70 psi, air flow is sufficient, and wiring on pressure switch is connected.
K9P1 or k9P2	Alarm	Bearing Air Removed	Speed Controller no longer detects bearing air.	

Table 6 Maintenance Advisories



Code	Event Type	Name	Description	Remedy
MD91	Advisory	Maintenance Valve Turbine Gun 1	Gun 1 Turbine valve is due for maintenance	<ul style="list-style-type: none"> Perform required maintenance Clear advisory and clear valve count on corresponding Maintenance Screen
MD92	Advisory	Maintenance Valve Turbine Gun 2	Gun 2 Turbine valve is due for maintenance	
MDA1	Advisory	Maintenance Valve Brake Gun 1	Gun 1 brake valve is due for maintenance	
MDA2	Advisory	Maintenance Valve Brake Gun 2	Gun 2 brake valve is due for maintenance	
MMUX	Advisory	Maintenance USB Logs Full	USB maintenance logs are full.	<ul style="list-style-type: none"> Use a USB drive to save maintenance logs

Repair

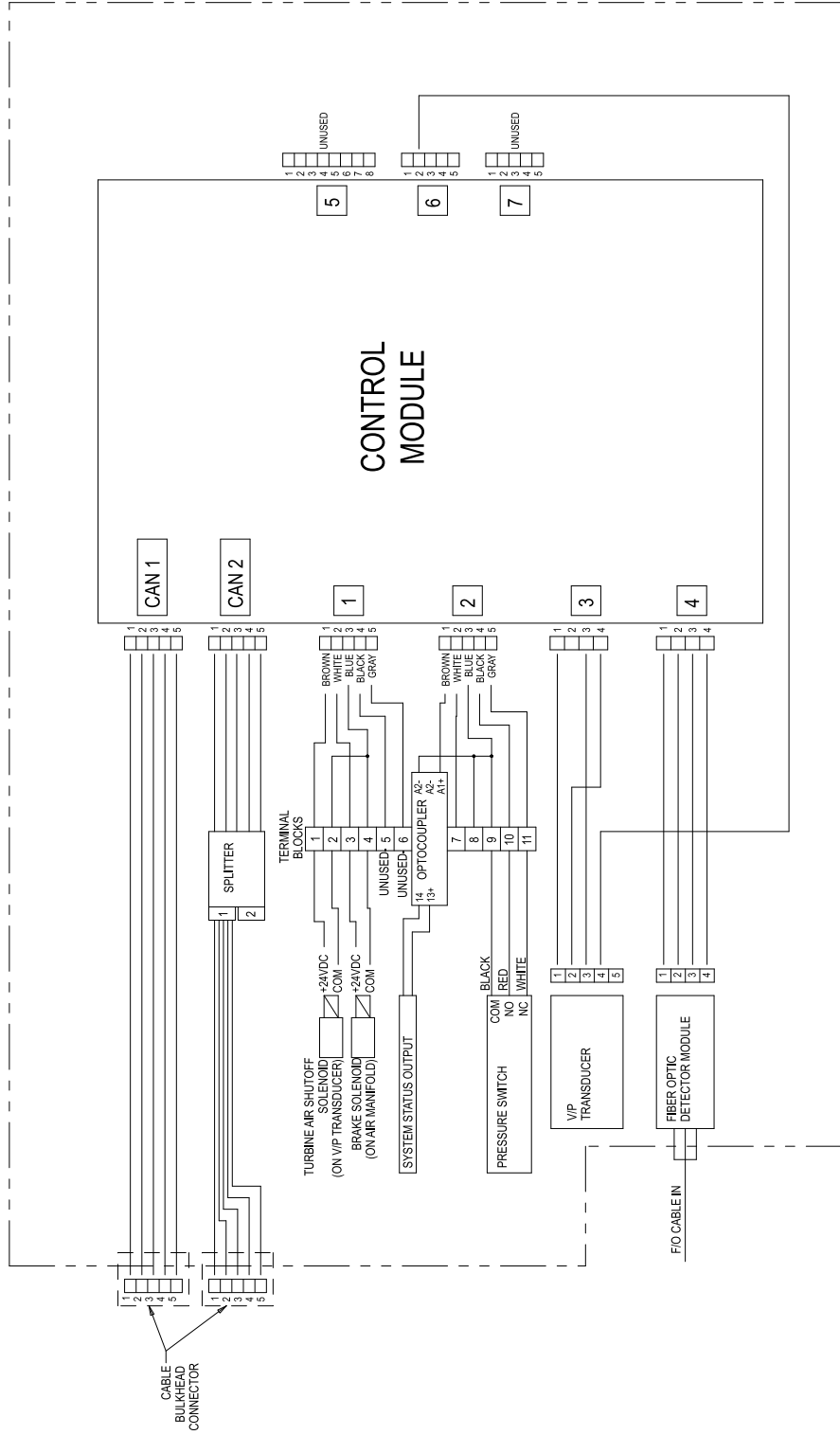
Electrical Schematic



Prepare for Service

				
<ul style="list-style-type: none"> • To avoid electric shock, remove power from the system before servicing. • All electrical wiring must be done by a qualified electrician and comply with all local codes and regulations. • Do not substitute or modify system components. • Read . 				

NOTICE

To avoid equipment damage, the bearing air must be on while the turbine is spinning and must not be turned off until the cup comes to a complete stop.

1. Verify that the cup is not rotating.
2. Close the air shutoff valve on the speed controller air supply line.
3. Unplug the power supply.

Replace the Fiber Optic Sensor

Follow these directions to replace the fiber optic sensor (19, Kit 24Z524).

1. Follow directions in [Prepare for Service, page 19](#).
2. Disconnect M8 cable (52) and fiber optic cable from the sensor assembly (19).
3. Loosen and remove the nut, then remove the fiber optic sensor assembly (19).

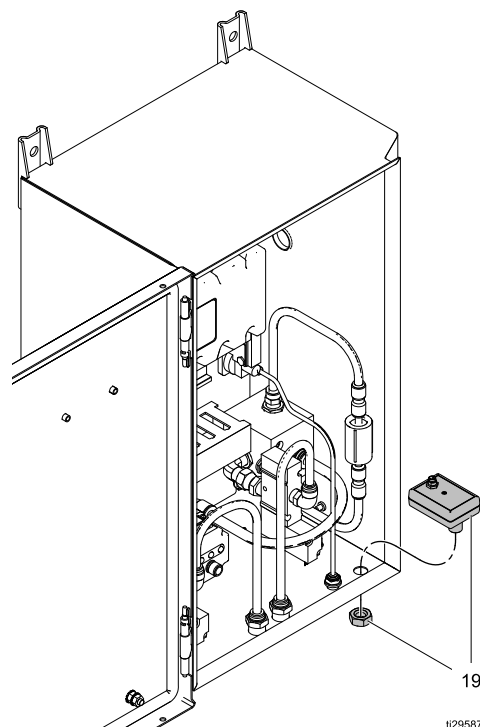

4. Install the new fiber optic sensor assembly (19) and tighten the nut. Do not overtighten.
5. Reconnect the M8 cable (52) and the fiber optic cable to the sensor assembly.

Replace A Solenoid Valve

Follow these directions to replace either the turbine air solenoid or the brake air solenoid (Kit 116463).

1. Follow directions in [Prepare for Service, page 19](#).
2. Disconnect air tubing (42).
3. Disconnect electrical wires. For the **turbine** solenoid (TA), disconnect the wires from terminal blocks 1 and 2. For the **brake** air solenoid (BK), disconnect the wires from terminal blocks 3 and 4.
4. Loosen the swivel on fitting (27). Remove the solenoid assembly.
5. Remove fitting (29) and muffler (14) from the solenoid (28).
6. Apply thread sealant to the threads on the fittings (27, 29). Tighten the fittings and the muffler (14) into the new solenoid (28).
7. Install the solenoid assembly and tighten the swivel on fitting (27).
8. **Turbine Air Solenoid (TA):** Connect the wires to terminal blocks 1 and 2. It doesn't matter which wire goes to which terminal.
9. **Brake Air Solenoid (BK):** Connect the wires to terminal blocks 3 and 4. It doesn't matter which wire goes to which terminal.
10. Reconnect air tubing (42).
11. Test using maintenance screens on System Logic Controller. See manual 3A3955, System Logic Controller, for more information.

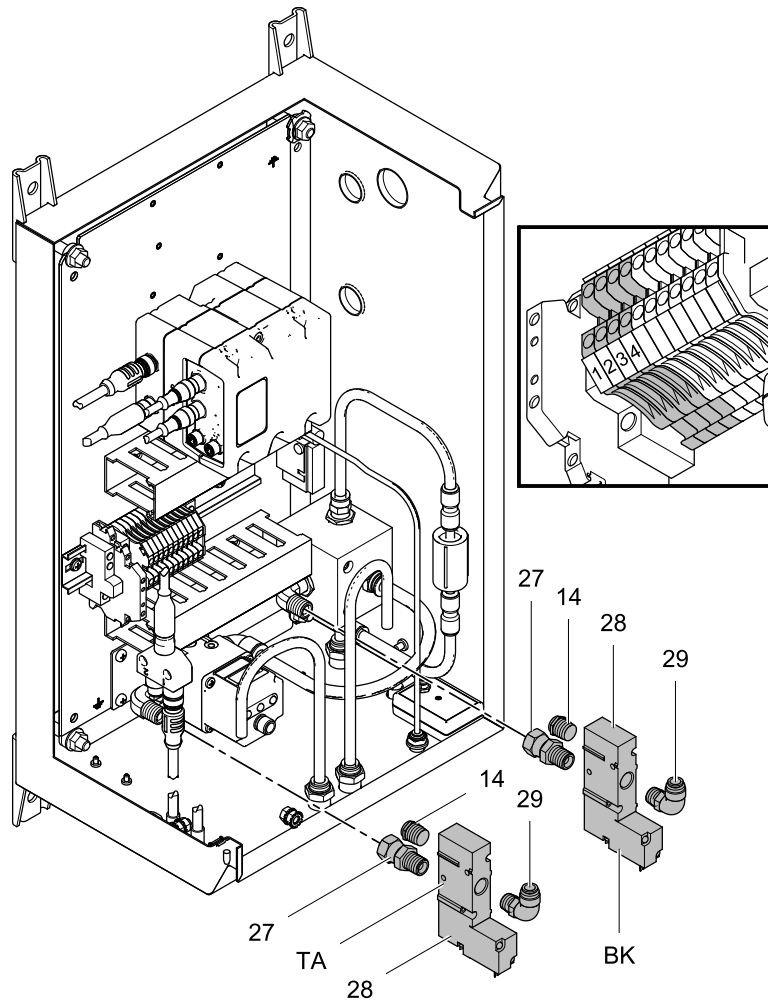

Replace the Control Module

Follow these instructions to replace the control module (Refs. 2 and 6). Order Kit 25C423, which includes the module and the necessary software token.

1. Follow directions in [Prepare for Service, page 19](#).
2. Label each cable with the number of the connection port. Disconnect all cables from both the base (2) and the control module (6).
3. Remove the module door (5).
4. Loosen the fasteners (6a) and remove the control module (6).
5. Remove fasteners (3, 4), then remove the base (2).
6. Install the new base (2). Tighten fasteners (3, 4).
7. Install the new control module (6). Tighten the fasteners (6a).
8. Reinstall the module door (5).
9. Refer to the labels to reconnect each cable. If you did not use labels, remove the wire duct cover. Refer to the schematic and the following table for connection information.
10. Load the correct software onto the control module, using the token.

NOTICE

The module will not work if the software is not installed. See directions in the System Logic Controller manual for loading the software.

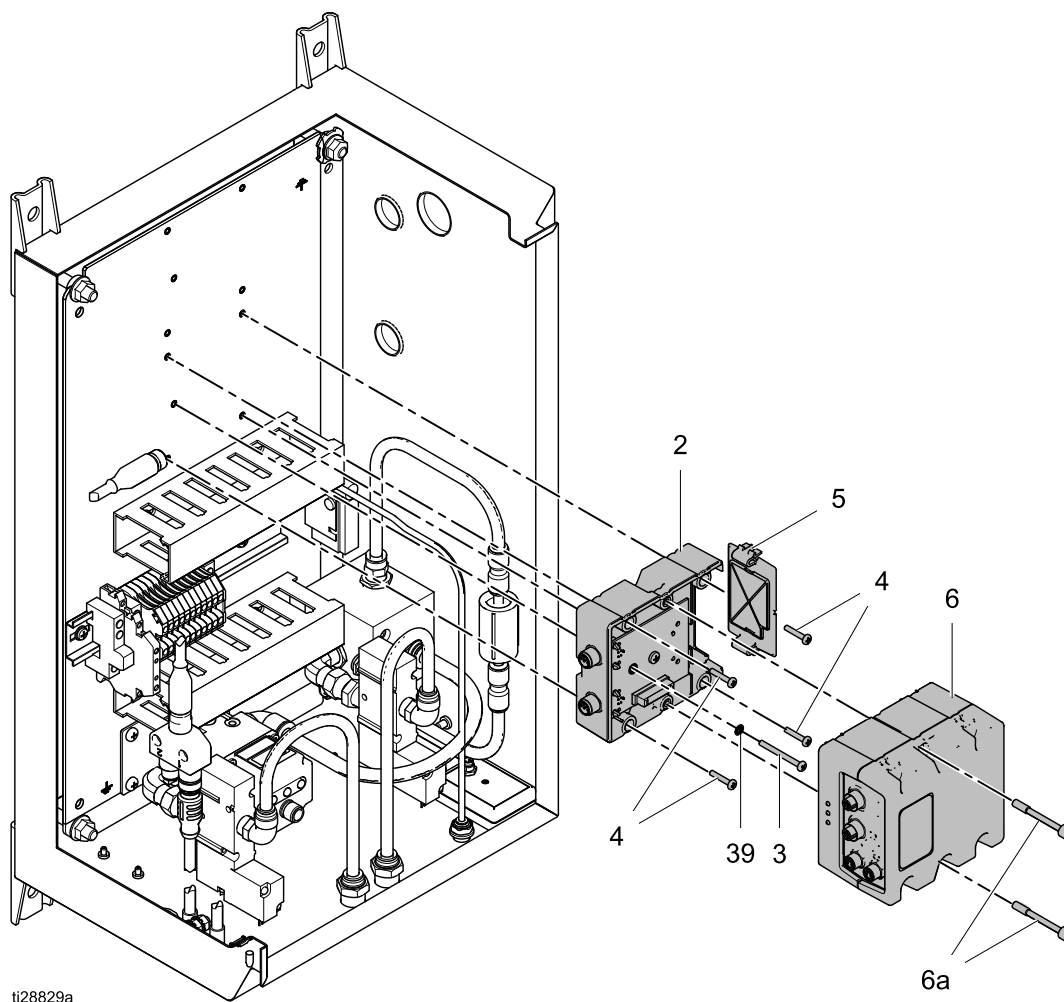

Repair

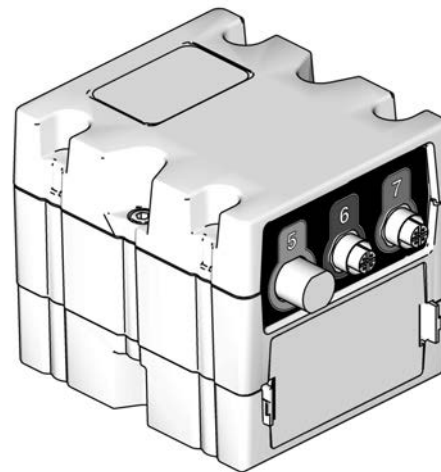
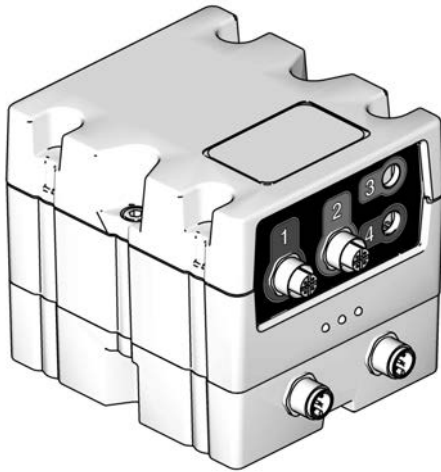

Module Connection	Purpose	System Connection
1	Turbine and Brake Air	Terminal Blocks 1–4
2	Pressure switch	Terminal Blocks 9–11
	System Status Optocoupler	Optocoupler (64)
3	Voltage to Pressure (V2P) Regulator	Cable (44), M8, 4–pin
4	Fiber/Optic Sensor	Cable (52), M8, 4–pin
5	Unused	
6	Voltage to Pressure (V2P) Regulator	Cable (44), M12, 5–pin
7	Unused	

Replace the Voltage to Pressure Regulator

Follow these directions to replace the voltage to pressure (V2P) regulator (9).

1. Follow directions in [Prepare for Service, page 19](#).
2. Remove the turbine air solenoid (28). See [Replace A Solenoid Valve, page 20](#).
3. Disconnect cable (44) and tube (40).
4. Remove screws (58) to remove the regulator assembly, including the bracket (57).
5. Remove screws (57a) to disconnect the regulator from the bracket.
6. Remove the elbow (15), muffler (14), and the reducer bushing (36).
7. Apply thread sealant to the threads on the elbow (15) and the reducer bushing (36). Tighten the elbow, the muffler, and the bushing into the new regulator (9).
8. Use screws (57a) to attach the new regulator (9) to the bracket.
9. Use screws (58) to attach the assembly to the controller box.
10. Reconnect the cable (44) and tube (40).
11. Reinstall the turbine air solenoid (28). See [Replace A Solenoid Valve, page 20](#).
12. Calibrate the regulator. See *Calibration Screen* in *Initial Setup* in the System Logic Controller manual (3A3955).

Note

For better accuracy, perform a “zero clear” as detailed in the instruction manual that is included with the V2P regulator. The unit should be powered on with no air applied.

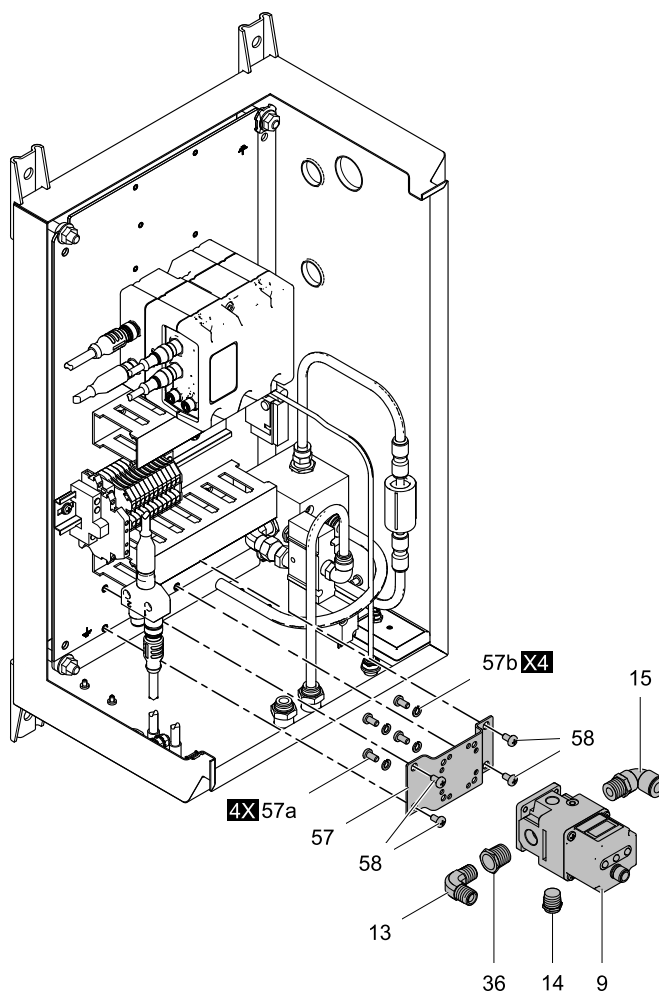

1128830a

Replace the Pressure Switch

Follow these directions to replace the pressure switch (20, Kit 26A292).

1. Follow directions in [Prepare for Service, page 19](#).
2. Disconnect the air tubing (41).
3. Disconnect the wires (66) from the pressure switch (20).
4. Remove two screws (47), then remove the pressure switch assembly.
5. Use screws (47) to attach the pressure switch assembly to the box.
6. Reconnect the wires (66).

Pressure Switch Wire	Terminal Block
COM	9
NO	10
NC	11

7. Reconnect the air tubing (41).

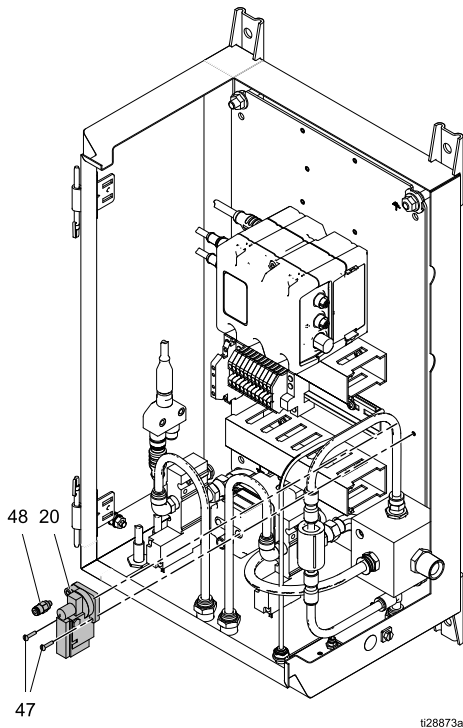

Replace the Bearing Air Filter

Follow these directions to replace the bearing air filter (80).

1. Follow directions in [Prepare for Service, page 19](#).
2. Remove connectors (81) from each side.
3. Install the new filter (80) on the bottom fitting (81).
Note the flow direction arrow on the filter. The flow should go from the air manifold block to the bulkhead on the enclosure.
4. Reattach the push-to-connect fitting (81) at the top.

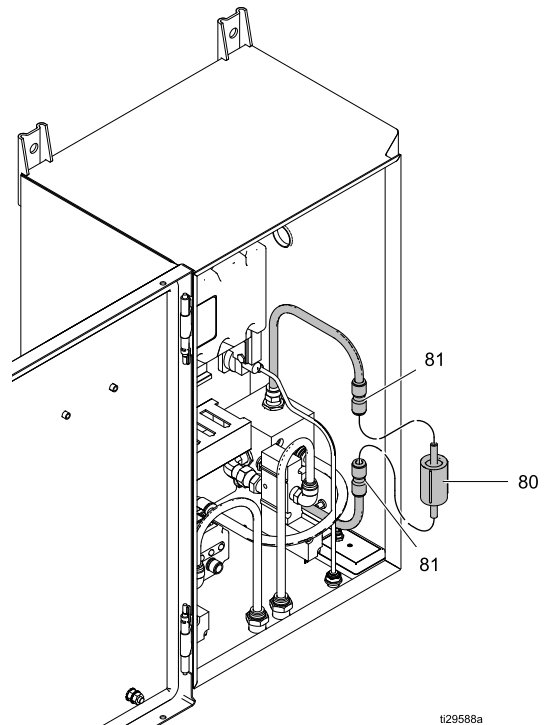

Parts

Model 24Z219—Speed Controller with System Logic Controller and Power Supply

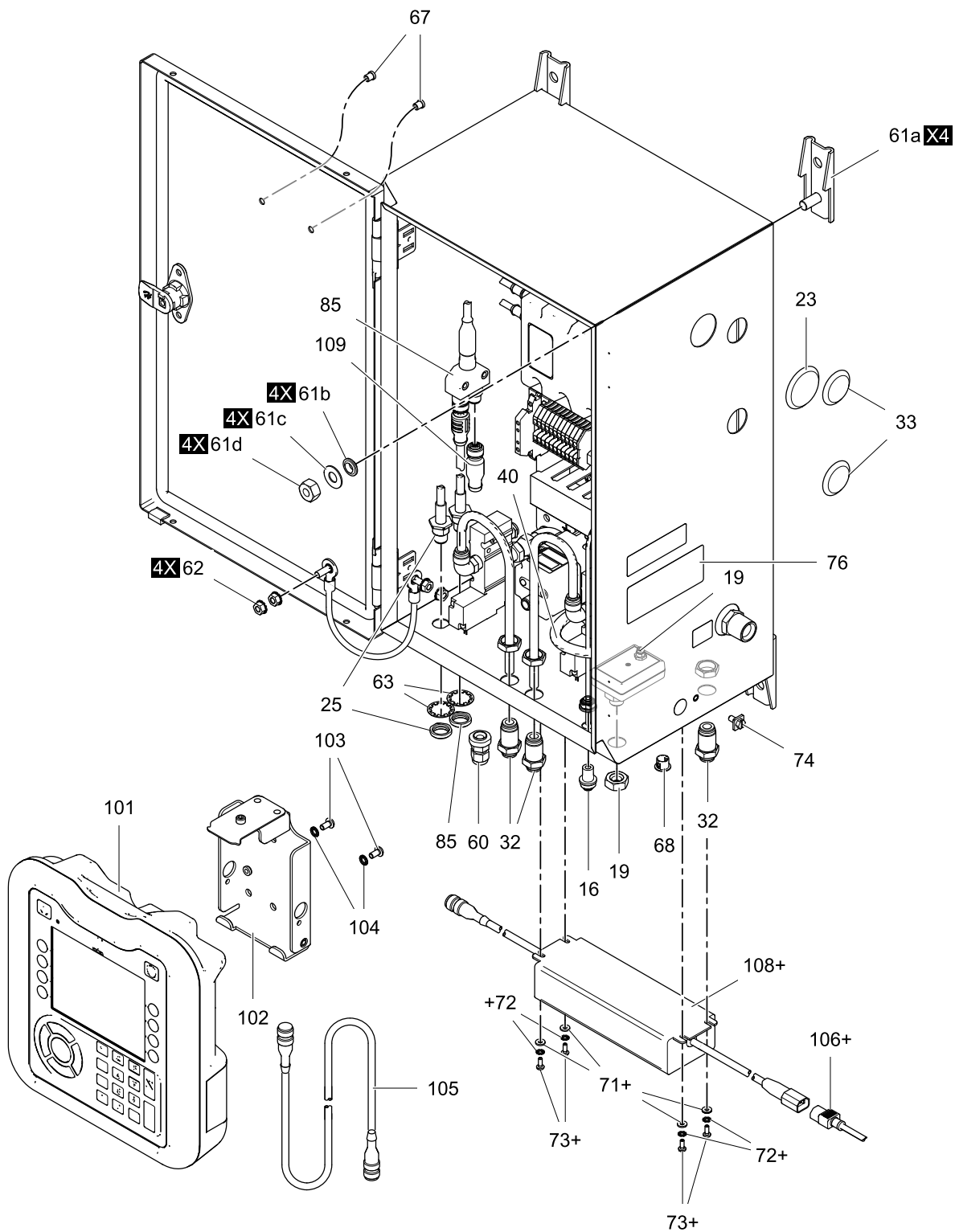

ti28838a

Model 24Z219-Speed Controller with System Logic Controller and Power Supply

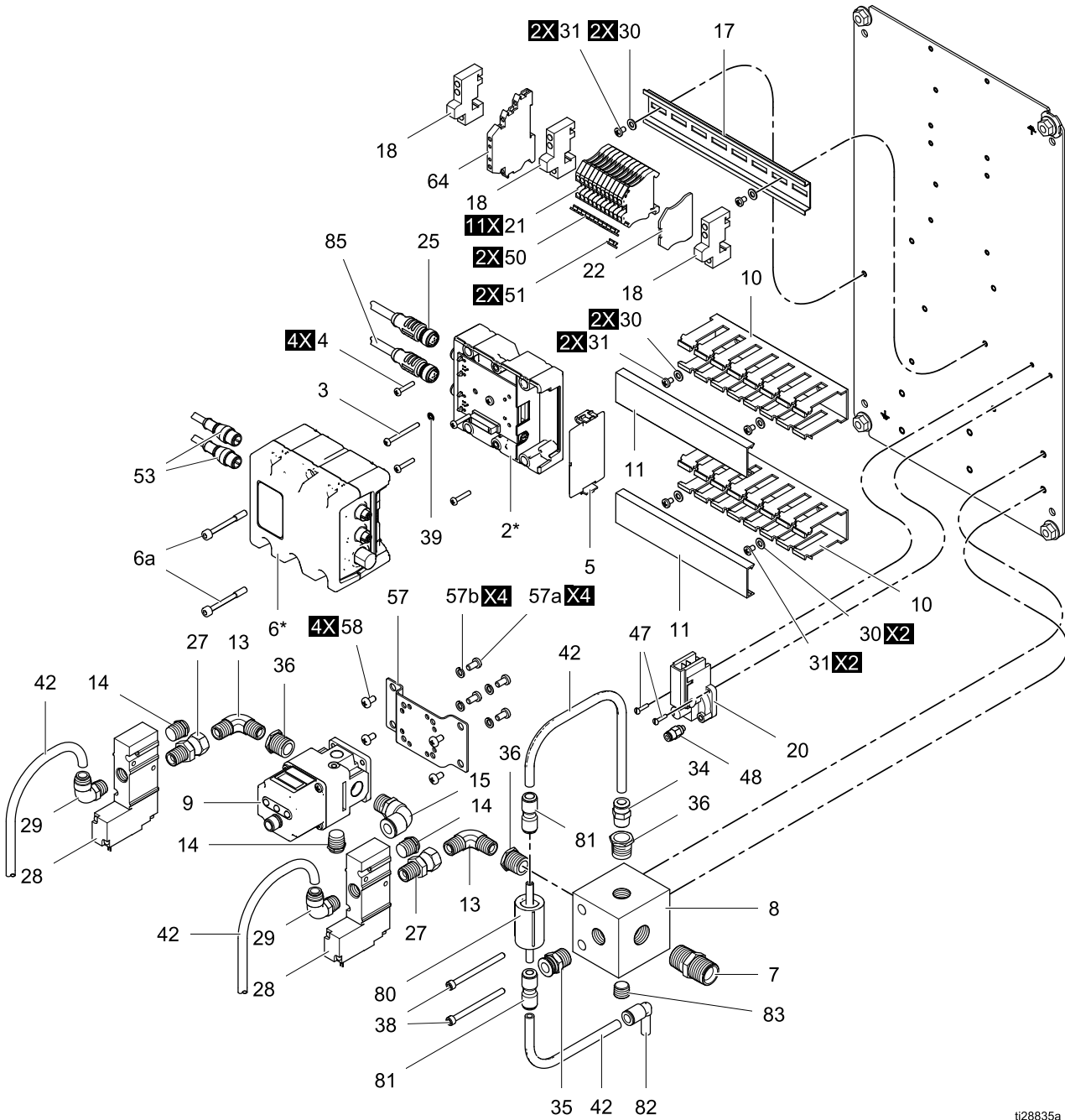

t28835a

Model 24Z219—Speed Controller with System Logic Controller and Power Supply

Ref	Part	Description	Qty
1	— — —	ENCLOSURE	1
2*	289697	BASE, control module	1
3	— — —	SCREW, machine, pan head, 6–32 x 1 1/2 in.	1
4	— — —	SCREW, machine, pan head, 6–32 x 0.75 in.	4
5	277674	DOOR, control module	1
6*	289696	MODULE, control	1
7	158491	NIPPLE, 1/2–14 npt	1
8	— — —	MANIFOLD	1
9	17G386	REGULATOR, voltage to pressure, 3/8 npt	1
10	— — —	DUCT, wire	1
11	— — —	COVER, wire duct	1
13	110249	ADAPTER, elbow, 1/4–18 npt	2
14	112173	MUFFLER	3
15	16F151	ELBOW, swivel, 3/8 npt	1
16	121818	BULKHEAD, tube, 5/32 OD	1
17	— — —	RAIL, mounting	1
18	112446	BLOCK, clamp end	3
19	24Z524	MODULE, fiber optic sensor	1
20	26A292	SWITCH, pressure; includes connector (Ref. 48) and screw (Ref. 47)	1
21	120419	BLOCK, terminal	11
22	120490	COVER, end	1
23	— — —	PLUG, button	1
25	— — —	CABLE, CAN, M12 female 5-pin QD connector to M12 male 5-pin bulkhead	1
27	156823	UNION, swivel, 1/4–18 npt to 1/4–18 npsm	2
28	116463	VALVE, solenoid, 3-way	2
29	115948	ELBOW, 1/4 npt(m) to 5/16T	2
30	110874	WASHER, flat	6
31	112144	SCREW, machine, pan head #8–32 x 0.25in.	6
32	— — —	BULKHEAD, union, tube, 5/16 OD	3
33	— — —	PLUG	2
34	115950	CONNECTOR, 1/4npt(m) to 5/16 T	1
35	15T546	FITTING, straight, 3/8 T x 3/8 npt(m)	1
36	C19675	BUSHING, reducer, 3/8 x 1/4	3

Ref	Part	Description	Qty
38	514930	SCREW, cap, socket head, #10–32 x 2.5in.	2
39	100272	WASHER, lock, #6	1
40	054134	TUBE, 3/8 OD	1 ft.
41	598095	TUBE, 5/32 OD,	1 ft.
42	054776	TUBE, 5/16 OD	3.5 ft.
44	17K902	HARNESS, M8 (4-pin) x M12 (5-pin)	1
47	100171	SCREW, pan head, #4–40 x 0.5 in.	2
48	— — —	CONNECTOR, 5/32 tube	1
49	— — —	CONNECTOR, terminal	3
50	— — —	MARKER, terminal block, 1–10	2
51	— — —	MARKER, terminal block, 11–20	2
52	17N184	CABLE, M8, 4-pin	1
53	— — —	CABLE, CAN, M12–5-pin	2
57	17D921	BRACKET, regulator	1
58	103833	SCREW, machine, #10–32 x 3/8 in.	4
60	111987	CONNECTOR, cord strain relief	1
61	— — —	BRACKET, mounting	1
62	— — —	WIRE, ground	1
63	101390	WASHER, lock	2
64	24Z226	OPTOCOUPLER, terminal block	1
65	— — —	LABEL, port identification	1
66	— — —	WIRE, 3 Conductor, 18 AWG, shielded	1
67	— — —	PLUG	2
68	125946	PLUG	1
71+	151395	WASHER, flat	4
72+	103181	WASHER, lock	4
73+	100518	SCREW, machine, pan head, #6–32 x 3/8 in.	4
74	116343	SCREW, ground	1
76▲	17K394	LABEL, warning	1
80	17M754	FILTER, coalescing	1
81	— — —	FITTING, reducer	2
82	— — —	ELBOW	1
83	100721	PLUG, pipe	1
85	— — —	CABLE, splitter, bulkhead	1
101	24Z223	MODULE, System Logic Control	1

Parts

Ref	Part	Description	Qty
102	277853	BRACKET, mounting	1
103	106084	SCREW, cap, M5-0.8 x 10 mm	2
104	111307	WASHERS, lock	2
105	121001	CABLE, CAN, 1 m (3.3 ft)	1
106 ⁺	245202	CORD SET with North America NEMA 5-15 male plug, 13A, 120V, 10 ft. (3 m), (not shown)	1
	121056	CORD SET with Continental Europe CEE 7/7 male plug, 16A, 250V, 8 ft. (2.4 m), (not shown)	1
	124864	CORD SET with Australia AS/NZS 3112 male plug, 10A, 250V, 8 ft. (2.4 m), (not shown)	1
	121057	CORD SET with United Kingdom BS 1363 plug, 8 ft (2.4 m), 10A, 250V	1
107	223547	WIRE, ground, 25ft. (7.6 m); not shown	1

Ref	Part	Description	Qty
108	24Z224	POWER SUPPLY, 24VDC, 2.5A, 60W; includes core (Ref. 106), washers (Refs. 71, 72) and screws (Ref. 73)	1
109	120999	RESISTOR, termination	1

▲ Replacement safety labels, tags, and cards are available at no cost.

* Included in Kit 25C423, replacement Control Module with Software.

+ Included in Kit 24Z224 Power Supply.

Kits and Accessories

Graco CAN Cables

Part	Length
130193	0.5 m (1.6 ft.)
121001	1 m (3.3 ft.)
121002	1.5 m (4.9 ft.)
121003	3 m (9.8 ft.)

Reflective Speed Sensor Kit 24Z183

Part	Description	Qty
— — —	CABLE, M8, 4-pin, 2m (6.6ft)	1
— — —	SENSOR, fiber optic	1
25A537	CABLE, fiber optic, for applicator	1
— — —	GLAND, cable, strain relief	2

ProBell Gateway Installation Kit 24Z574

Part	Description	Qty
24Z578	TOKEN, programming	1
130193	CABLE, CAN, 0.5 m	1
121901	SUPPRESSOR	2
— — —	SCREW, machine, 6-32 x 1-1/2	1
100272	WASHER, lock, #6	1
— — —	SCREW, #6-32 x 0.75 in.	4
— — —	Grommet, bulkhead, cable entry	1

Optocoupler Kit 24Z226

Part	Description	Qty
— — —	Block, terminal, optocoupler	1

Communication Gateway Kits

Part	Description
CGMDN0	DeviceNet
CGMEP0	EhterNet IP
24W462	Modbus TCP
CGMPN0	PROFINET

Fiber Optic Cables

Part	Length	Style
24Z190	36 ft (11 m)	Standard
24Z191	66 ft (20 m)	Standard
24Z192	99 ft (30 m)	Standard
24Z193	36 ft (11 m)	Hollow Wrist
24Z194	66 ft (20 m)	Hollow Wrist
24Z195	99 ft (30 m)	Hollow Wrist

Fiber Optic Cable Repair and Accessories

Kit Number	Description
24W875	Fiber Optic Repair Kit — Includes fittings for one double-strand fiber optic cable and a cutter tool.
24W876	Fiber Optic Bulkhead Fitting, stainless steel, Qty. 2 — Accepts Graco fiber optic cable fittings. Fits 1/2 in. (13 mm) panel hole.
24W877	Fiber Optic Bulkhead, plastic, Qty. 2 — Accepts bare fiber optic cable. Fits 5/16 in. (8 mm) panel hole.
24W823	Fiber Optic Cutter Tool, Qty. 3
24X009	Marker Numbers for Fiber Optic Cable Ends, pack of 30 (#1 and #2).

Power Supply Kit 24Z224

Part	Description	Qty
— — — —	POWER SUPPLY, 24VDC, 2.5A, 60W	1
245202	CORD, power, USA, 10 ft. (3 m), 13A, 120V (not shown)	1
151395	WASHER, flat	4
103181	WASHER, lock	4
100518	SCREW, machine, pan head, #6-32 x 3/8 in.	4

ProBell Token Programming Kit 17M465

System Logic Controller Screen Protector 15V511

Technical Specifications

ProBell Speed Controller		
	US	Metric
Maximum air working pressure	100 psi	0.69 MPa, 7.0 bar
Turbine speed, maximum operating	60,000 rpm	
Bearing air, minimum required	70 psi	0.5 MPa, 5.0 bar
Air connection	1/2" npt	
Maximum operating voltage	24 VDC, 2.5A	
Power connection for part 24Z224	Straight IEC 320-C13 male connector. Also included with part 24Z219: North America NEMA 5-15 male plug Australia AS/NZS 3112 male plug Continental Europe CEE 7/7 male plug United Kingdom, BS 1363 male plug	
External power requirements for part 24Z224	100–240 VAC, 50/60 Hz, 2A maximum draw, 15 amp circuit breaker is recommended	
Operating temperature range	32° to 122°F	0° to 50°C
Storage temperature range	-22° to 140°F	-30° to 60°C
Weight (Model 24Z219)	34 lb	15.4 kg

California Proposition 65

CALIFORNIA RESIDENTS

 **WARNING:** Cancer and reproductive harm — www.P65warnings.ca.gov.

Graco Standard Warranty

Graco warrants all equipment referenced in this document which is manufactured by Graco and bearing its name to be free from defects in material and workmanship on the date of sale to the original purchaser for use. With the exception of any special, extended, or limited warranty published by Graco, Graco will, for a period of twelve months from the date of sale, repair or replace any part of the equipment determined by Graco to be defective. This warranty applies only when the equipment is installed, operated and maintained in accordance with Graco's written recommendations.

This warranty does not cover, and Graco shall not be liable for general wear and tear, or any malfunction, damage or wear caused by faulty installation, misapplication, abrasion, corrosion, inadequate or improper maintenance, negligence, accident, tampering, or substitution of non-Graco component parts. Nor shall Graco be liable for malfunction, damage or wear caused by the incompatibility of Graco equipment with structures, accessories, equipment or materials not supplied by Graco, or the improper design, manufacture, installation, operation or maintenance of structures, accessories, equipment or materials not supplied by Graco.

This warranty is conditioned upon the prepaid return of the equipment claimed to be defective to an authorized Graco distributor for verification of the claimed defect. If the claimed defect is verified, Graco will repair or replace free of charge any defective parts. The equipment will be returned to the original purchaser transportation prepaid. If inspection of the equipment does not disclose any defect in material or workmanship, repairs will be made at a reasonable charge, which charges may include the costs of parts, labor, and transportation.

THIS WARRANTY IS EXCLUSIVE, AND IS IN LIEU OF ANY OTHER WARRANTIES, EXPRESS OR IMPLIED, INCLUDING BUT NOT LIMITED TO WARRANTY OF MERCHANTABILITY OR WARRANTY OF FITNESS FOR A PARTICULAR PURPOSE.

Graco's sole obligation and buyer's sole remedy for any breach of warranty shall be as set forth above. The buyer agrees that no other remedy (including, but not limited to, incidental or consequential damages for lost profits, lost sales, injury to person or property, or any other incidental or consequential loss) shall be available. Any action for breach of warranty must be brought within two (2) years of the date of sale.

GRACO MAKES NO WARRANTY, AND DISCLAIMS ALL IMPLIED WARRANTIES OF MERCHANTABILITY AND FITNESS FOR A PARTICULAR PURPOSE, IN CONNECTION WITH ACCESSORIES, EQUIPMENT, MATERIALS OR COMPONENTS SOLD BUT NOT MANUFACTURED BY GRACO. These items sold, but not manufactured by Graco (such as electric motors, switches, hose, etc.), are subject to the warranty, if any, of their manufacturer. Graco will provide purchaser with reasonable assistance in making any claim for breach of these warranties.

In no event will Graco be liable for indirect, incidental, special or consequential damages resulting from Graco supplying equipment hereunder, or the furnishing, performance, or use of any products or other goods sold hereto, whether due to a breach of contract, breach of warranty, the negligence of Graco, or otherwise.

FOR GRACO CANADA CUSTOMERS

The Parties acknowledge that they have required that the present document, as well as all documents, notices and legal proceedings entered into, given or instituted pursuant hereto or relating directly or indirectly hereto, be drawn up in English. Les parties reconnaissent avoir convenu que la rédaction du présente document sera en Anglais, ainsi que tous documents, avis et procédures judiciaires exécutés, donnés ou intentés, à la suite de ou en rapport, directement ou indirectement, avec les procédures concernées.

Graco Information

For the latest information about Graco products, visit www.graco.com. For patent information, see www.graco.com/patents.

To place an order, contact your Graco Distributor or call to identify the nearest distributor.

Phone: 612-623-6921 **or Toll Free:** 1-800-328-0211 **Fax:** 612-378-3505

All written and visual data contained in this document reflects the latest product information available at the time of publication.

Graco reserves the right to make changes at any time without notice.

Original Instructions. This manual contains English, MM 3A3953

Graco Headquarters: Minneapolis

International Offices: Belgium, China, Japan, Korea

GRACO INC. AND SUBSIDIARIES • P.O. BOX 1441 • MINNEAPOLIS, MN 55440-1441 • USA

Copyright 2016, Graco Inc. All Graco manufacturing locations are registered to ISO 9001.

www.graco.com
Revision E, October 2024