

10:1 Dyna-Star[®] Pump Module with Auto-Fill Shutoff

3A3429E
EN

Provides lubricant flow and pressure to operate a single line parallel automatic lubrication system. For automatic lubrication systems only. For professional use only.



Important Safety Instructions

Read all warnings and instructions in this manual and related manuals. Save all instructions.

Single Line Parallel Automatic Lubrication Systems

24Y408: 60 Pound Pump Module

24Y407: 90 Pound Pump Module

25C948: 60# Pump Module with low level sensor

25C949: 90# Pump Module with low level sensor

3500 psi (24 MPa, 240 bar) Maximum Lubricant Outlet Pressure

3500 psi (24 MPa, 240 bar) Maximum Hydraulic Fluid Inlet Pressure

5000 psi (34 MPa, 344.7 bar) Maximum Refilling Inlet Pressure

Related Manuals

Manual	Description
312350	Dyna-Star Hydraulic Reciprocator and Pump
309099	Vent Valve Kit
333393	Fill Valve
3A2960	GLC2200 Lubrication Controller

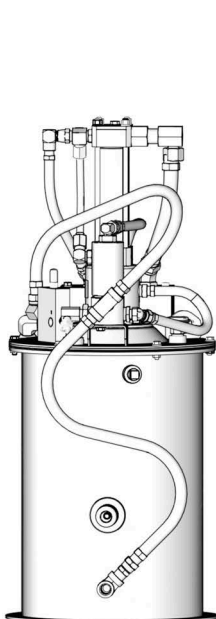

Model 25C948

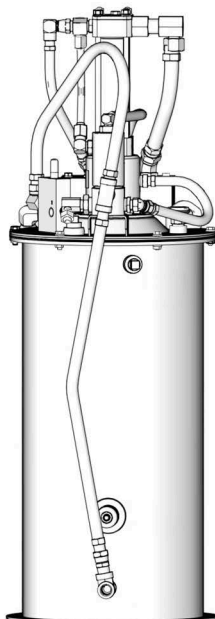

Model 25C949

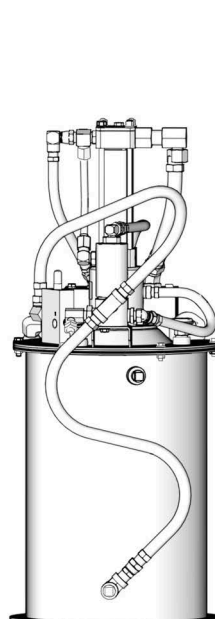

Model 24Y408

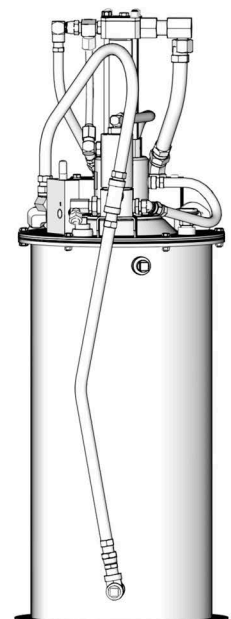









Model 24Y407

Table of Contents







Warnings	3
Installation	5
Grounding	5
Pump Module	5
Typical Installation (with pressure relief valve) . . .	7
Low Level Sensor	8
Typical Installation (with fill valve)	10
Operation	12
Pressure Relief Procedure	12
Pump Module Operation	12
Auto-Fill Shut Off (S)	13
Refilling the Reservoir	13
Shut Down	15
Service	16
Troubleshooting	16
Parts Drawing	18
Parts List	20
Technical Data	22
Dimensions	23
Graco Information	24

Warnings

The following warnings are for the setup, use, grounding, maintenance, and repair of this equipment. The exclamation point symbol alerts you to a general warning and the hazard symbols refer to procedure-specific risks. When these symbols appear in the body of this manual or on warning labels, refer back to these Warnings. Product-specific hazard symbols and warnings not covered in this section may appear throughout the body of this manual where applicable.

 <h1 style="margin: 0;">WARNING</h1>	
 	<p>FIRE AND EXPLOSION HAZARD</p> <p>When flammable fluids are present in the work area, such as gasoline and windshield wiper fluid, be aware that flammable fumes can ignite or explode. To help prevent fire and explosion:</p> <ul style="list-style-type: none"> • Use equipment only in well ventilated area. • Eliminate all ignition sources, such as cigarettes and portable electric lamps. • Ground all equipment in the work area. • Keep work area free of debris, including rags and spilled or open containers of solvent and gasoline. • Do not plug or unplug power cords or turn lights on or off when flammable fumes are present. • Use only grounded hoses. • Stop operation immediately if static sparking occurs or you feel a shock. Do not use equipment until you identify and correct the problem. • Keep a working fire extinguisher in the work area.
    	<p>SKIN INJECTION HAZARD</p> <p>High-pressure fluid from dispensing device, hose leaks, or ruptured components will pierce skin. This may look like just a cut, but it is a serious injury that can result in amputation. Get immediate surgical treatment.</p> <ul style="list-style-type: none"> • Do not point dispensing device at anyone or at any part of the body. • Do not put your hand over the fluid outlet. • Do not stop or deflect leaks with your hand, body, glove, or rag. • Follow the Pressure Relief Procedure when you stop dispensing and before cleaning, checking, or servicing equipment. • Tighten all fluid connections before operating the equipment. • Check hoses and couplings daily. Replace worn or damaged parts immediately.
	<p>TOXIC FLUID OR FUMES HAZARD</p> <p>Toxic fluids or fumes can cause serious injury or death if splashed in the eyes or on skin, inhaled, or swallowed.</p> <ul style="list-style-type: none"> • Read Safety Data Sheet (SDS) to know the specific hazards of the fluids you are using. • Store hazardous fluid in approved containers, and dispose of it according to applicable guidelines.

⚠️ WARNING



 	<p>EQUIPMENT MISUSE HAZARD</p> <p>Misuse can cause death or serious injury.</p> <ul style="list-style-type: none"> • Do not operate the unit when fatigued or under the influence of drugs or alcohol. • Do not exceed the maximum working pressure or temperature rating of the lowest rated system component. See Technical Data in all equipment manuals. • Use fluids and solvents that are compatible with equipment wetted parts. See Technical Data in all equipment manuals. Read fluid and solvent manufacturer's warnings. For complete information about your material, request Safety Data Sheet (SDS) from distributor or retailer. • Turn off all equipment and follow the Pressure Relief Procedure when equipment is not in use. • Check equipment daily. Repair or replace worn or damaged parts immediately with genuine manufacturer's replacement parts only. • Do not alter or modify equipment. Alterations or modifications may void agency approvals and create safety hazards. • Make sure all equipment is rated and approved for the environment in which you are using it. • Use equipment only for its intended purpose. Call your distributor for information. • Route hoses and cables away from traffic areas, sharp edges, moving parts, and hot surfaces. • Do not kink or over bend hoses or use hoses to pull equipment. • Keep children and animals away from work area. • Comply with all applicable safety regulations.
 	<p>MOVING PARTS HAZARD</p> <p>Moving parts can pinch, cut or amputate fingers and other body parts.</p> <ul style="list-style-type: none"> • Keep clear of moving parts. • Do not operate equipment with protective guards or covers removed. • Pressurized equipment can start without warning. Before checking, moving, or servicing equipment, follow the Pressure Relief Procedure and disconnect all power sources.
	<p>BURN HAZARD</p> <p>Equipment surfaces and fluid that is heated can become very hot during operation. To avoid severe burns:</p> <ul style="list-style-type: none"> • Do not touch hot fluid or equipment.
	<p>PERSONAL PROTECTIVE EQUIPMENT</p> <p>Wear appropriate protective equipment when in the work area to help prevent serious injury, including eye injury, hearing loss, inhalation of toxic fumes, and burns. Protective equipment includes but is not limited to:</p> <ul style="list-style-type: none"> • Protective eyewear, and hearing protection. • Respirators, protective clothing, and gloves as recommended by the fluid and solvent manufacturer.

Installation

Read and follow instructions supplied with each system component.

				
<p>LIFTING HAZARD This equipment is heavy. Lifting or moving heavy equipment incorrectly can cause serious injury such as muscle strain or back injuries. To avoid injury:</p> <ul style="list-style-type: none"> • Do not lift or move this equipment without assistance. • Always use a lifting device secured to the pump lift ring when moving or installing this equipment. See Technical Data, page 22 for pump weight. 				

Grounding

				
<p>The equipment must be grounded to reduce the risk of static sparking. Static sparking can cause fumes to ignite or explode. Grounding provides an escape wire for the electric current.</p>				

For Mobile Installations

Mount reservoir (K) (FIG. 2, page 7) to a grounded chassis member.

For Non-mobile Installations (FIG. 1)

1. Remove ground screw (gs) and insert through eye in ring terminal at the end of the ground wire.
2. Fasten ground screw (gs) back into pump and tighten securely.
3. Connect other end to a true earth ground.

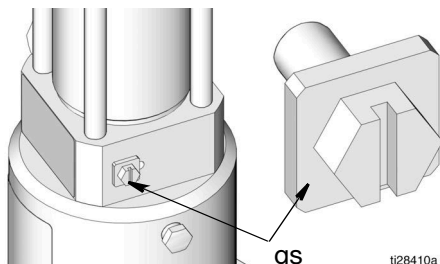





FIG. 1

Pump Module

Mount the reservoir (K) on sturdy, flat surface with 6 (six), 3/8-inch diameter bolts. Locate the high pressure lubricant supply lines (W) and hydraulic lines (T and G) for easy access once installed.

- The hydraulic system must be depressurized before connecting high pressure lubricant supply lines (W).
 - Be sure breather (J) is not plugged before filling reservoir (K).
 - The hydraulic oil supply must be 10 μ filtered or better and supply 0.5 - 3.0 gpm (1.9 - 11.4 lpm) at 300 psi - 3500 psi (21 bar - 241 bar (2.1 MPa - 24 MPa).
1. Install Ball Valve (A) (user provided) in the 3/8-inch High Pressure Hydraulic Line (G) (FIG. 2, page 7).
 2. Connect the 3/4-inch hydraulic tank line (T) (FIG. 2, page 7) to the tank hydraulic connection swivel (PP) (FIG. 9, page 11).
 3. Connect the 24 VDC timer controlled signal to the 3-way solenoid valve (JJ) (FIG. 9, page 11).
 4. Connect high pressure lubricant supply line (W) (FIG. 2, page 7) to the lubricant output connection (CC) (FIG. 8, page 11).
 5. Ground system (see **Grounding**).
 6. Connect the 3/8-inch high pressure hydraulic line (G) (FIG. 2, page 7) to the high pressure hydraulic connection swivel (Y) (FIG. 9, page 11).





Inlet and Outlet Components

				
<p>COMPONENT RUPTURE HAZARD The maximum working pressure of the inlet and outlet components in the system vary. Over-pressurizing an inlet or outlet can cause it to rupture resulting in property damage and serious injury such as skin injection or injury from splashing fluid. To reduce the risk of component rupture:</p> <ul style="list-style-type: none"> • Be sure to know the maximum working pressure of each inlet and outlet component in the system. • Never exceed the maximum working pressure of the inlet and outlet components. 				

Setting the Hydraulic Pressure and Flow Rate

1. Set the hydraulic pump pressure to the lowest pressure needed using the pressure reducing valve (NN). This setting should be between 250 - 350 psi (1.7 to 2.4 MPa, 17.0 to 24.1 bar).
2. Set the hydraulic flow rate to pump at lowest rate/cycles needed using flow control valve (KK) to get desired pump speed.
3. With a primed pump and sufficient hydraulic supply, the pump starts when the timer activates the solenoid valve. The pump stops when the timer deactivates the solenoid valve.

Refilling Pump (P) Requirements

				
<p>The remote filling station pump stalls (dead-heads) when the reservoir is full, causing the supply system pressure to rise to the maximum output pressure of the filling station pump. To help prevent equipment damage or serious injury caused by pressurized fluid, such as skin injection or injury from splashing fluid, always use a remote filling station pump with a maximum output pressure of 5000 psi (34 MPa, 344.7 bar) and use a refill line with a pressure rating equal to or greater than the refill pump.</p>				

Refilling Line (D) Requirements

To relieve the stall pressure in the refilling line (D) a pressure relief valve (H) (FIG. 2, page 7) or a fill valve (Z) (FIG. 7, page 10) **must** be installed in the system.

Systems without Fill Valve

A pressure relief valve (H) and overflow container (N) for collecting excess fluid that drains during pressure relief, must be installed in an easily accessible location between the remote filling station pump (P) and the Auto-Fill Shut Off (S). This pressure relief valve is used to relieve pressure in the refilling line (D) and to reset the Auto-Fill Shut Off. See **Typical Installation**, page 7.

A Pressure Relief Kit: 247902 is available from Graco. Contact your distributor or Graco Customer Service for additional information about this kit.

Systems with Fill Valve (Z)

Install the fill valve (Z) in an easily accessible location between the remote fill station pump (P) and Auto-Fill Shut Off Valve (S). See **Typical Installation**, page 10.

The fill valve is used to relieve pressure in the refilling line (D) and to reset the Auto-Fill Shut Off (S). See the fill valve instruction manual 333393. Graco fill valve, part no. 77X542 is available. Contact your local Graco distributor.

Typical Installation

Systems with Pressure Relief Valve in the Refilling Line

The installation shown is only a guide for selecting and installing system components. Contact your Graco distributor for assistance in planning a system.

NOTE: The remote filling station pump stalls (dead-heads) when the reservoir is full. If the pump does not stall (dead-head) there is a leak in the system.

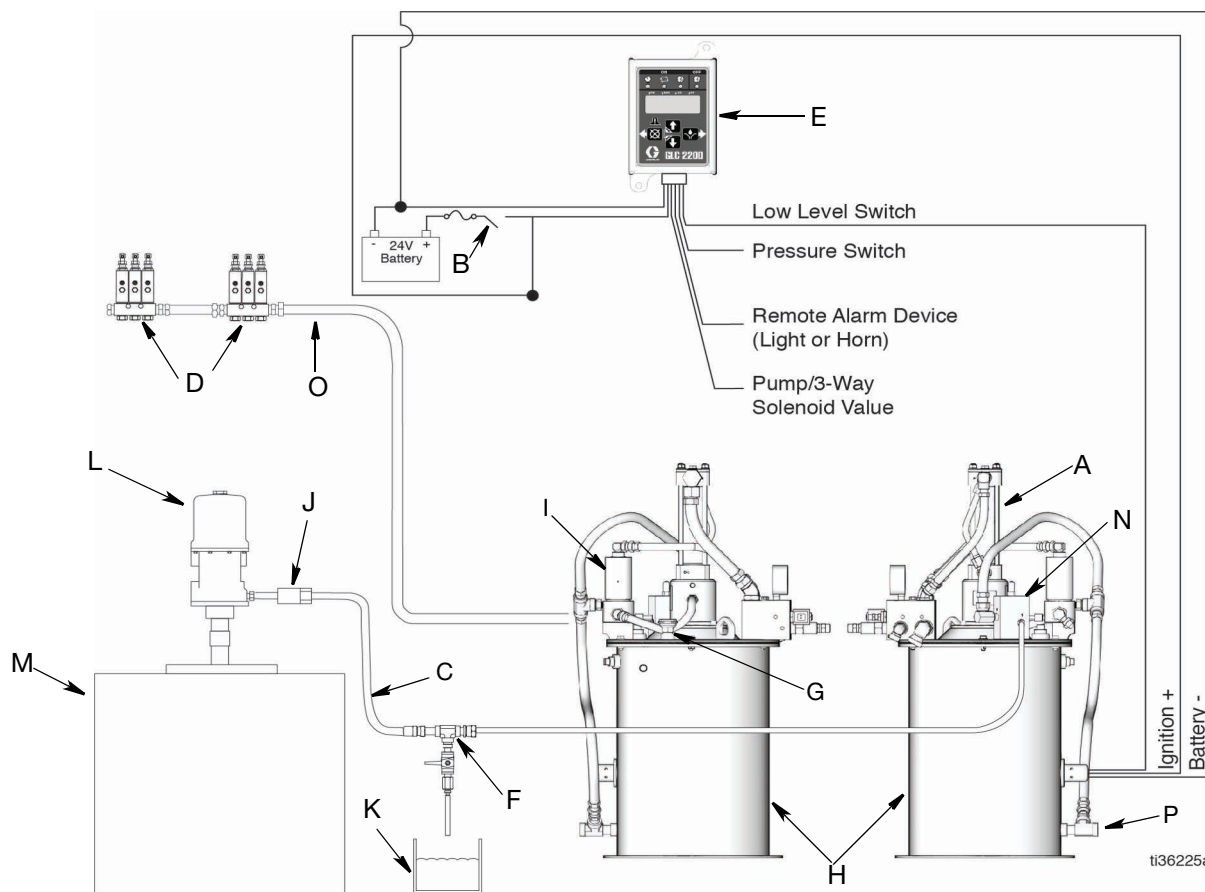

FIG. 2

Key:

- A Pump
- B Ignition switch
- C Refilling Line
- D Injector banks
- E Lubrication controller
- F Pressure Relief Valve*
- G Breather
- H Reservoir
- I Vent Valve
- J Filter (recommended if grease/environment is contaminated)
- K Fluid overflow container*
- L Pump - remote filling station
- M Reservoir - remote filling station
- N Auto-Fill Shut Off
- O High-pressure lubricant supply line
- P Low level sensor

* A pressure relief valve (F) and overflow container (K) for collecting excess fluid that drains during pressure relief **must** be installed in an easily accessible location between the remote filling station pump (L) and the Auto-Fill Shut Off (N). This pressure relief valve is used to relieve pressure in the refilling line and to reset the Auto-Fill Shut Off.

Low Level Sensor

When grease is present the LED is green. When the lubricant level in the reservoir reaches approximately 30% (low level), the LED turns amber. See the table and FIG. 3.

Condition	LED Color	Out 2 (Pin #2) (See Fig. 12,)
Grease present	Green	0VDC
No grease present	Amber	24 VDC

At 30% capacity, the amber low level signals the tank is reaching a point where the operator should refill the tank. There is still lubricant in the tank and immediate shutdown is not required.

If you are using a GLC2200 (part number 24N468, Series F or later only), the system enters a low level warning condition (LL03) after the switch input is closed for more than 1 second. However, the pump continues to operate.

Graco GLC2200 (part number 24N468, Series F or later only) can be used to run the pump and monitor the low level. Refer to FIG. 5 for Low Level Sensor wiring in systems controlled with a GLC2200. A Low Level Sensor cable (part number 129072) and a GLC2200 Wiring Harness (part number 24P314) are required.

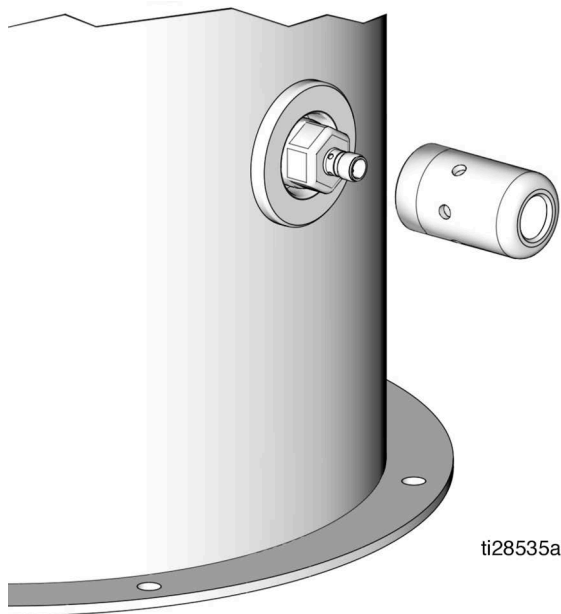

FIG. 3

Keep the sensor protective cover (12c on page 17) installed to prevent sensor damage.

Low level sensor wiring instructions begin below.

Low Level Sensor Wiring with GLC2200 Lube Controller

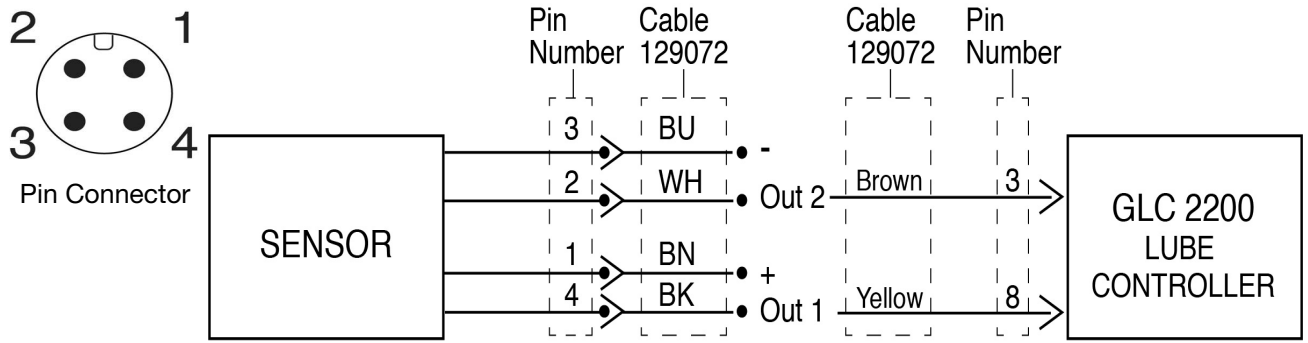
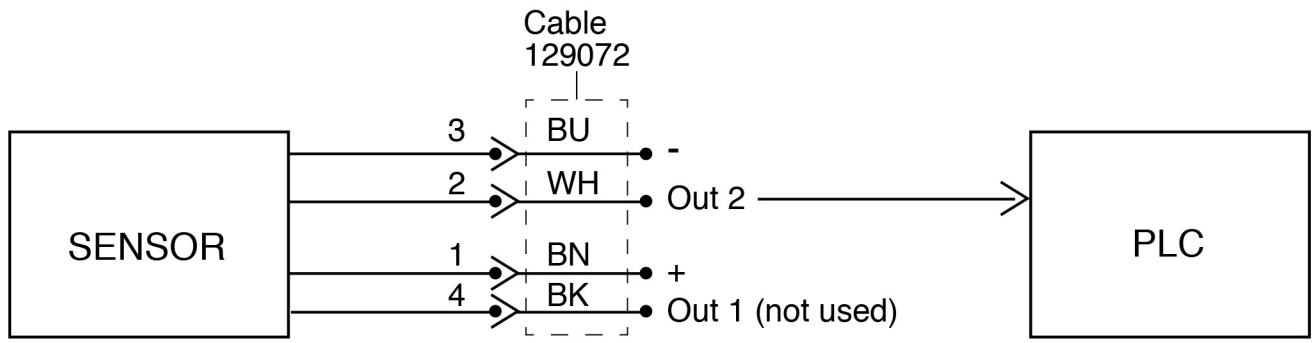

FIG. 4

Sensor behaves as a source style sensor



Sensor behaves as a source style sensor

ti28995a

FIG. 5

Low Level Sensor Wiring with GLC4400

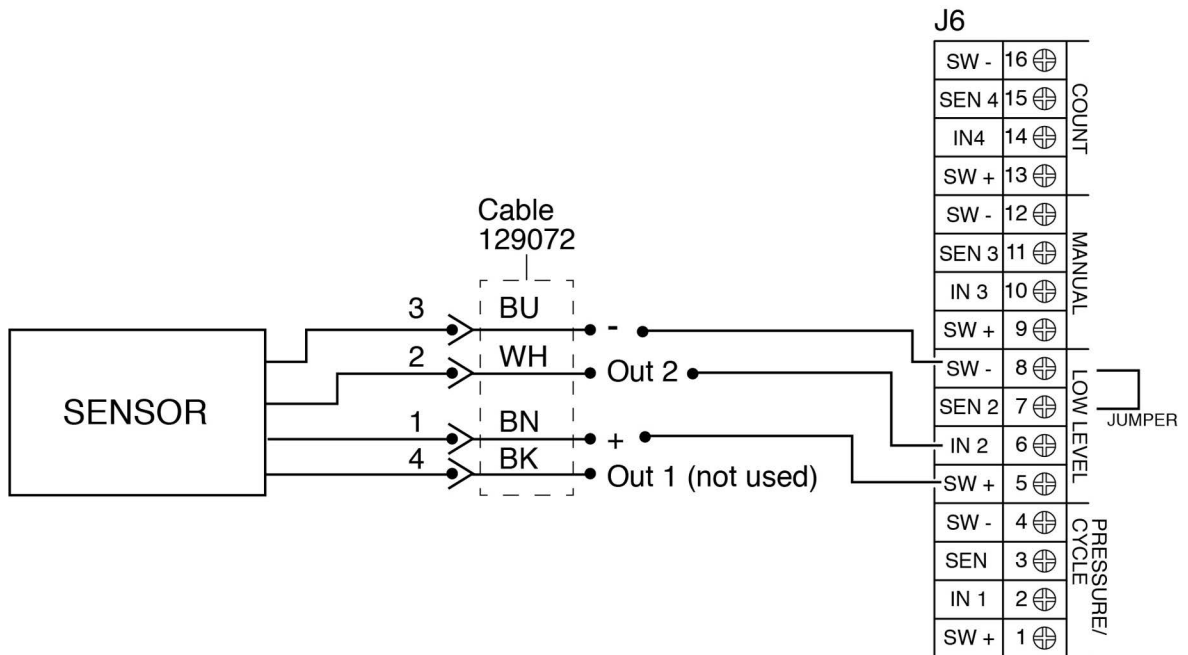

ti31998a

FIG. 6

Typical Installation

Systems with Fill Valve in the Refilling Line

The installation shown is only a guide for selecting and installing system components. Contact your Graco distributor for assistance in planning a system.

NOTE: The remote filling station pump stalls (dead-heads) when the reservoir is full. If the pump does not stall (dead-head) there is a leak in the system.

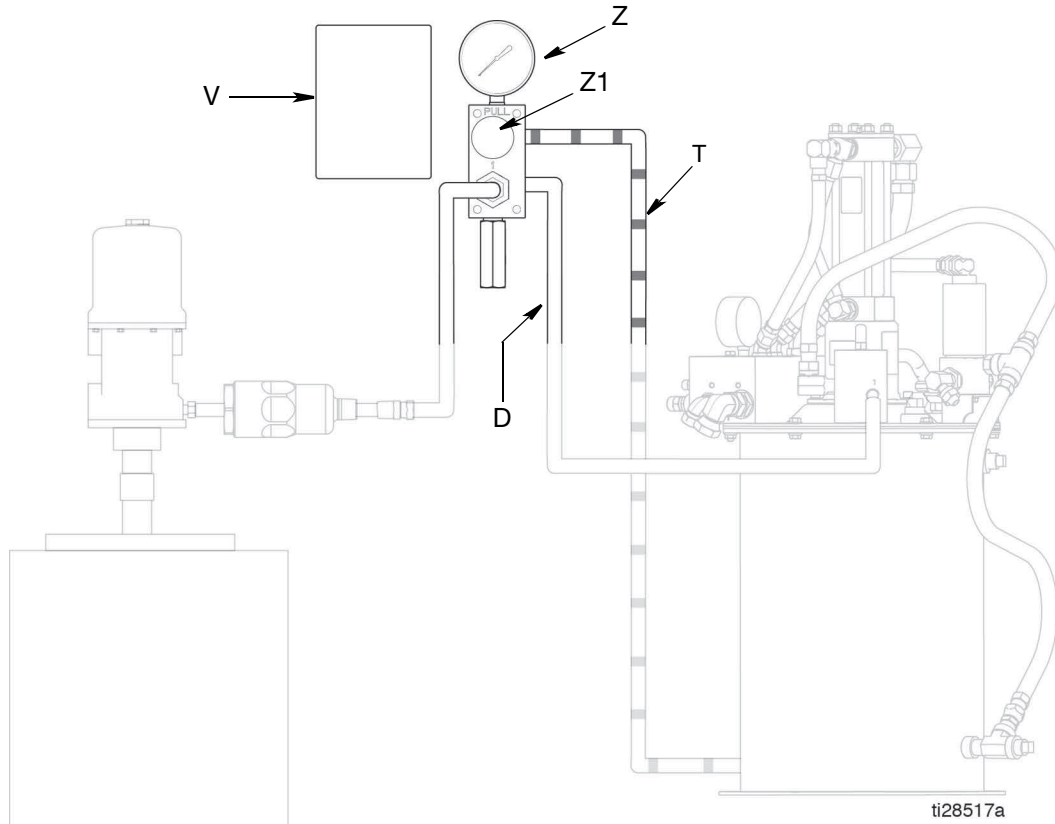

FIG. 7

Key:

- D Refilling Line
- T Pressure Relief Line
- V Instruction Label
- Z Fill Valve◆
- Z1 Pressure Relief Knob

◆ Install the fill valve (Z) in an easily accessible location between the remote fill station pump (P) and Auto-Fill Shut Off Valve (S).

The fill valve is used to relieve pressure in the refilling line and to reset the Auto-Fill Shut Off.

NOTE: The components highlighted in FIG. 7 identify the unique features in a Fill Valve installation. See Typical Installation on page 7 for a complete list of the other system components.

Vent Valve Connection

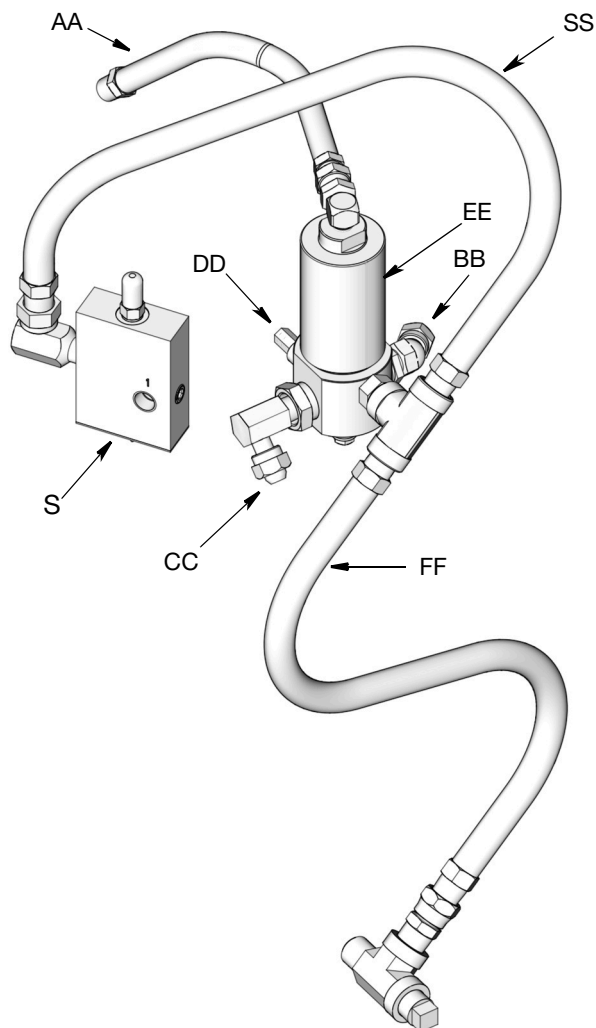

FIG. 8

Key:

- AA Vent Valve hydraulic control line
- BB Pump output connection line
- CC Lubricant output
- DD Pressure relief valve
- EE Vent valve
- FF Vent line
- SS Refilling line
- S Auto-Fill Shut Off

Control Module Connection

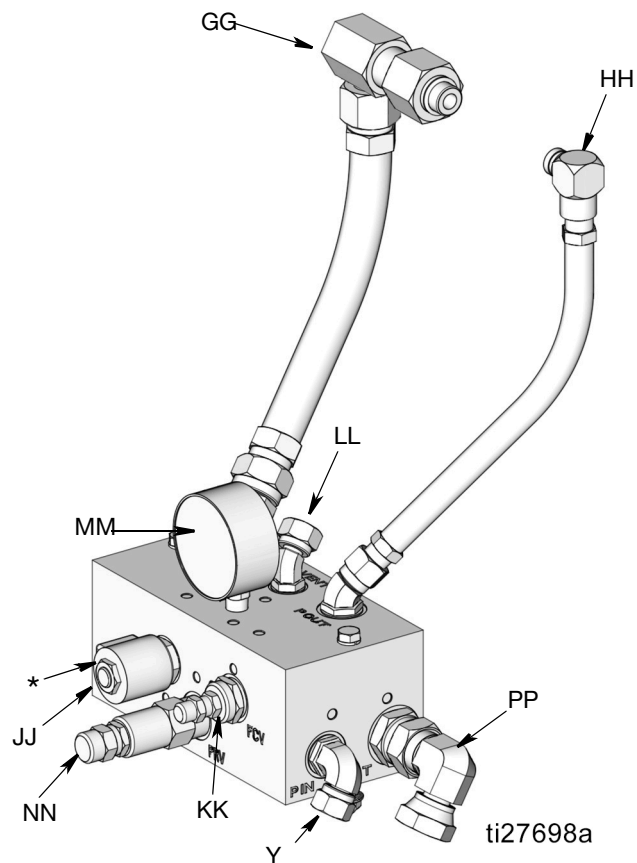

FIG. 9

Key:

- GG Pump tank line
- HH Pump high pressure hydraulic line
- JJ 3-way solenoid valve
- KK Flow control valve
- LL Vent valve hydraulic control
- MM Regulated hydraulic pressure gauge
- NN Pressure reducing valve
- PP Hydraulic tank connection (swivel)
- Y High pressure hydraulic connection (swivel)

*coil should always be installed with lettering facing out

Operation

NOTE: Unless otherwise noted, the reference letters used in the following instructions refer to FIG. 2, page 7.

Pressure Relief Procedure



Follow the Pressure Relief Procedure whenever you see this symbol.



This equipment stays pressurized until pressure is manually relieved. To help prevent serious injury from pressurized fluid, such as skin injection, splashing fluid and moving parts, follow the Pressure Relief Procedure when you stop dispensing and before cleaning, checking, or servicing the equipment.

1. Disable hydraulic supply to pump (B) by isolating it from the high pressure hydraulic supply using ball valve (A).
2. Do one of the following:
 - Cycle the timer [lubrication controller (F)] to open the 3-way solenoid valve to reduce trapped hydraulic pressure.

or

 - Open pressure reducing valve (NN) to reduce trapped hydraulic pressure (FIG. 9, page 11).
- NOTE:** The gauge (MM) on control module should read zero pressure after performing this step.
3. Disconnect power from lubrication controller (F).
4. **Relieve pressure** in high pressure supply lines (W) using two wrenches working in opposite directions to **slowly loosen fitting only** until fitting is loose and no more lubricant or air is leaking from fitting.

Pump Module Operation

Pump Modules for injector-based, Automatic Lubrication Systems: provide lubricant flow and pressure to operate a single line parallel automatic lubrication system. The module requires a hydraulic power supply and a timed signal from a lubrication controller. Based on these signals, the pump module provides lubricant flow and pressure to operate the injectors and vents the injector system to reset the injectors.

NOTICE
<p>Never allow pump to run dry of the fluid being pumped. A dry pump will quickly accelerate to a high speed, possibly damaging the pump. If your pump accelerates quickly, or is running too fast, stop the pump immediately and check the fluid supply.</p>

1. Upon receiving a signal from a 24-volt lubrication controller (F), the 3-way solenoid valve opens, starting the pump (B) and closes the vent valve (L).
2. The pump builds pressure until the pressure switch in the system sends a signal to the lubrication controller (F) ending the cycle, or the pump (B) stalls.
3. The lubrication controller (F) terminates the 24-volt signal to the 3-way solenoid valve.
4. The 3-way solenoid valve closes, stopping the pump (B) and opening the vent valve (L) into the reservoir (K).
5. The pressure reducing valve (NN) and flow control valve (KK) control the pump output pressure and cycle rate (FIG. 9, page 11).

Auto-Fill Shut Off

The Auto-Fill Shut Off (S) is used for refilling the grease tank/reservoir in an automatic lubrication system.

NOTE: For systems without a fill valve, see **Refilling Systems without a Fill Valve** instructions beginning on page 13. For systems with a fill valve, see **Refilling Systems with a Fill Valve** beginning on page 14.

As grease is added to the reservoir, it pushes the diaphragm up to the top of the reservoir. The diaphragm then pushes the valve pin and closes the inlet fluid path.

When the fluid refilling path closes, the refilling line (D) pressurizes and brings the refilling pump (P) to a pressurized stall condition.

NOTE: The operator must monitor system while filling tank to reduce the risk of accidental fluid overflow.

Refilling the Reservoir

Refilling Systems without a Fill Valve

1. Connect refilling line (D) from remote filling station pump (P) to the Auto-fill Shutoff inlet (FIG. 2, page 7).
2. Turn on remote filling station pump (P) and fill reservoir (K) until the indicator pin on the Auto-Fill Valve (S) pushes up as shown in FIG. 10. Pressure in the refill pump (P) builds and the pump stalls.

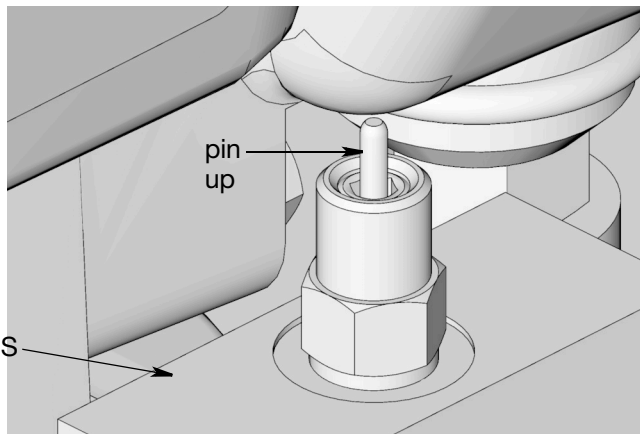
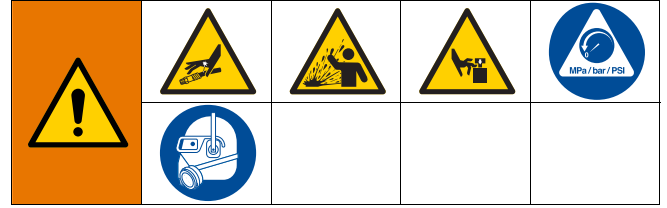

FIG. 10

3. Turn off air supply to refill pump (P).



4. Relieve pressure between the remote filling station pump (P) and the Auto-Fill Shut Off (S):
 - a. Open ball valve (bv) (FIG. 11). Pressure will be released and excess fluid will drain out of the drain tube (dt) and into the lubrication collection container (N).

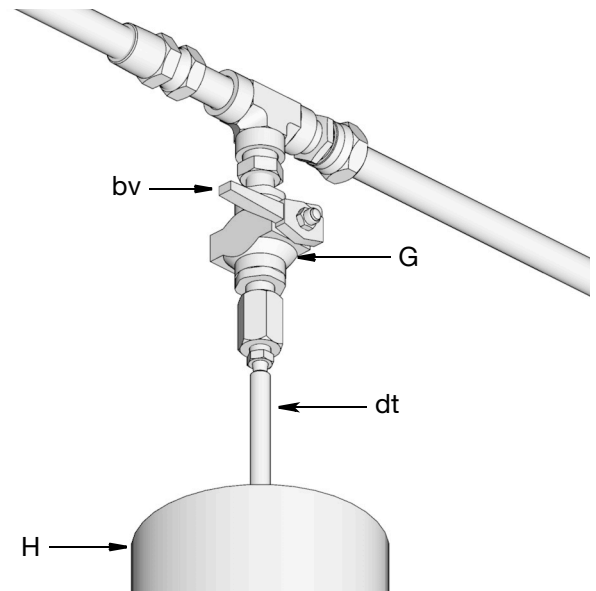

FIG. 11: In line installation shown

- b. Close ball valve (bv) when all pressure has been relieved.

NOTE: The pin may not drop and the Auto-Fill Shut Off may not reset because the tank is full. However, when the pump begins using the grease, the pin resets. The pin must reset before the next cycle of refilling.

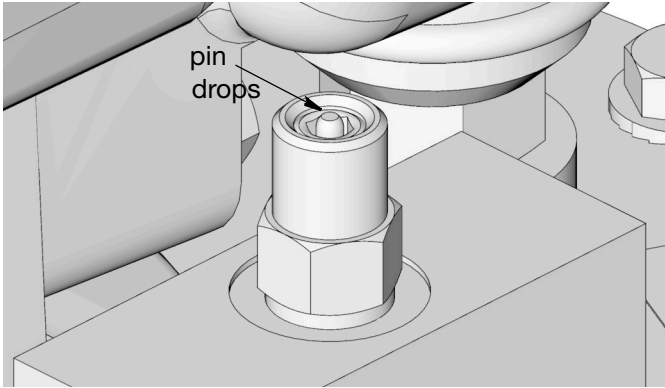

FIG. 12

5. Disconnect lubrication supply hose from the Auto-Fill Shut Off (S).
6. Install plugs in the Auto-Fill Shut Off inlet and the refilling line (D) to prevent contaminants from entering the pump.

Refilling Systems with a Fill Valve

1. Prior to starting the fill, pull out and hold black pressure relief knob (Z1) long enough to relieve line pressure between fill valve (Z) (FIG. 13) and Auto-Fill Shut Off (S).

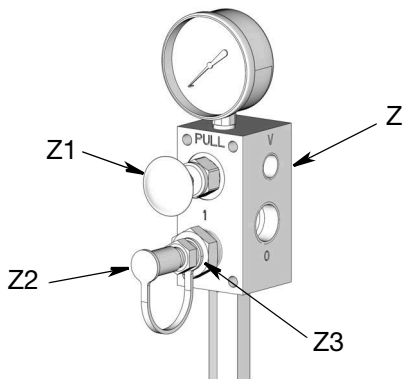

FIG. 13

2. Verify the Auto-Fill Shut Off (S) pin is down, indicating it is reset (FIG. 14).

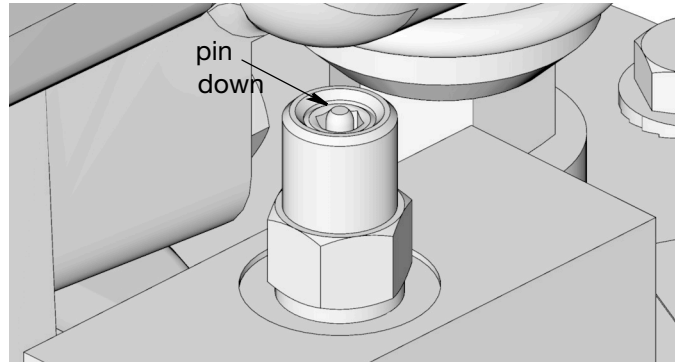

FIG. 14

3. Remove the yellow dust cover (Z2) from fill coupler (Z3) (FIG. 13, page 14).
4. Connect the refilling line (D) between the remote filling station's pump (P) and fill coupler (Z3) port marked with an "1" (FIG. 13, page 14).
5. Start the remote filling station pump (P).
6. When reservoir (K) is filled:
 - the remote filling station pump (P) stalls (dead-heads),
 - the Auto-Fill Shut Off (S) pin pops up (FIG. 15),
 - the gauge pressure in the refilling line (D) rises to the fill pump's set pressure.

NOTE: If the pump does not stall (dead-head) there is a leak in the system.

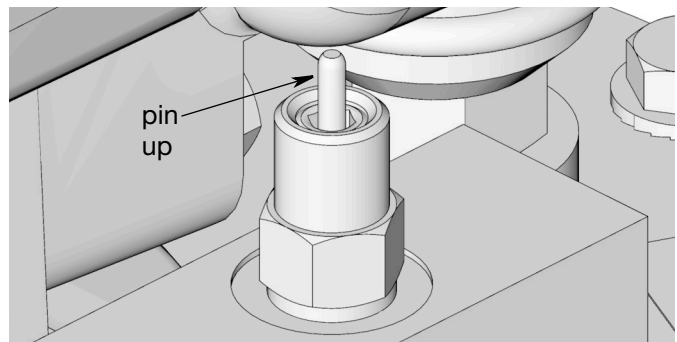
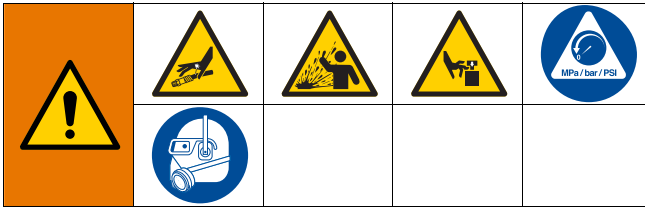

FIG. 15



7. Relieve pressure between remote filling station pump (P) and the fill valve (Z):
 - a. Turn off the remote filling station pump (P).
 - b. Pull out and hold black pressure relief knob (Z1) long enough to relieve line pressure between fill valve (Z) and Auto-Fill Shut Off Valve (S) and between the remote filling station pump (P) and fill valve (Z).

NOTE: The length of time it takes to vent varies depending on the system design and installation. In some installations it may be necessary to repeat Step b to ensure pressure is relieved.

- c. Disconnect the refilling line (D) at the fill coupler (Z3).
- d. Replace the yellow dust cover (Z2).

Shut Down

(For these instructions, see FIG. 2, page 7).

1. For normal system shut down, disconnect power to lubricator controller (F) by turning off the ignition switch.
2. Turn of hydraulic supply by closing ball valve (A).

Service

Use only Genuine Graco Repair Parts.

See separate system component manuals for service instructions. For pump service see manual 312350. For vent valve service see manual 309099.

Troubleshooting



Problem	Cause	Solution
System does not build sufficient pressure.	Pump (B) malfunction.	Refer to manual 312350.
	Pump (B) turned off too soon.	Increase lubrication controller (F) "pump on" setting. Increase hydraulic flow rate to pump (F).
	Solenoid (JJ) malfunction.	Repair or replace solenoid (JJ).
	Too low or no hydraulic supply.	Turn pressure up or supply on.
	Vent valve (L) seal failure.	Replace seal.
	Vent valve (L) needle/seat failure.	Replace needle and seat.
	Reservoir (K) out of grease.	Fill reservoir (K).
	Broken or leaky supply/branch line.	Tighten connections and/or replace line(s).
	Injector failure.	Repair or replace injector.
Lubricant dispensed from pressure relief valve.	System pressure set too high.	Decrease hydraulic pressure to pump.
	Pump (B) runs too fast.	Reservoir (K) out of lubricant. Leak in distribution system.
Lubricant coming out of breather (J).	Reservoir (K) overfilled because Auto-Fill Shut Off (S) did not shut the refilling line (D).	Replace the Auto-Fill Shut Off (S) diaphragm (9) and Auto-Fill Shut Off valve (8).

Problem	Cause	Solution
Pump (B) will not start.	No hydraulic supply.	Verify/check hydraulic supply.
	Solenoid (JJ) malfunction.	Replace solenoid (JJ).
	No electrical supply to lubrication controller (F).	Turn on electrical supply.
	Lubrication controller (F) malfunction.	Refer to lubrication controller manual.
	Pump (B) malfunction.	Refer to pump manual 312350.
Refilling pump (P) slows down or stalls and no output at the fill valve (Z).	Auto-Fill Shut Off Valve (S) has not reset	Relieve all refilling line (D) pressure. see page 13.
		Make sure Auto-Fill Shut Off (S) pin is down. See FIG. 14, page 14.
Refilling pump (P) runs continuously but does not stall.	Leakage in the system	Inspect the refilling line (D) and correct any leaks.

Parts Drawing

(See Parts List, page 20)

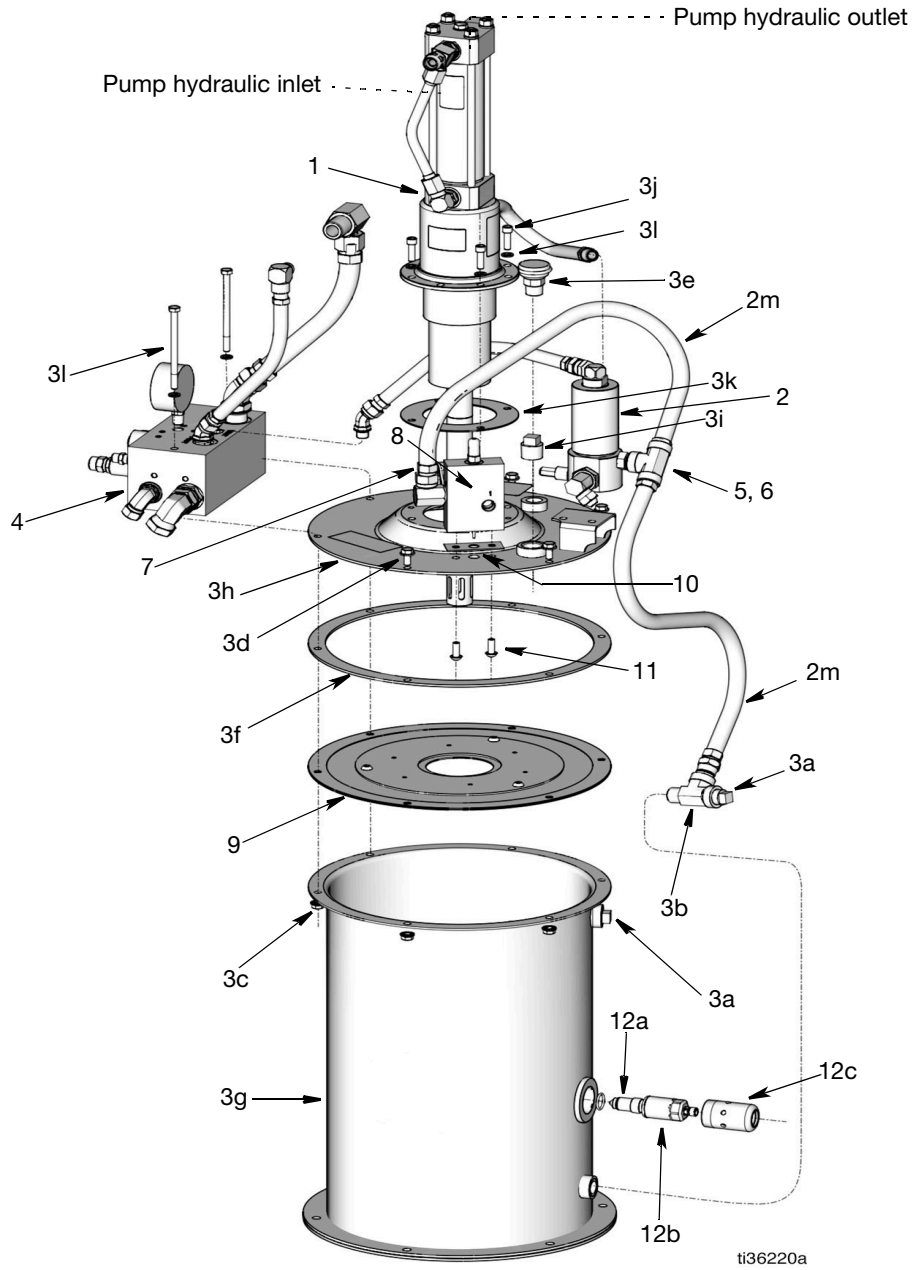

Parts Drawing

Vent Valve Kit (2): 243170

Control Module Kit (4): 247538

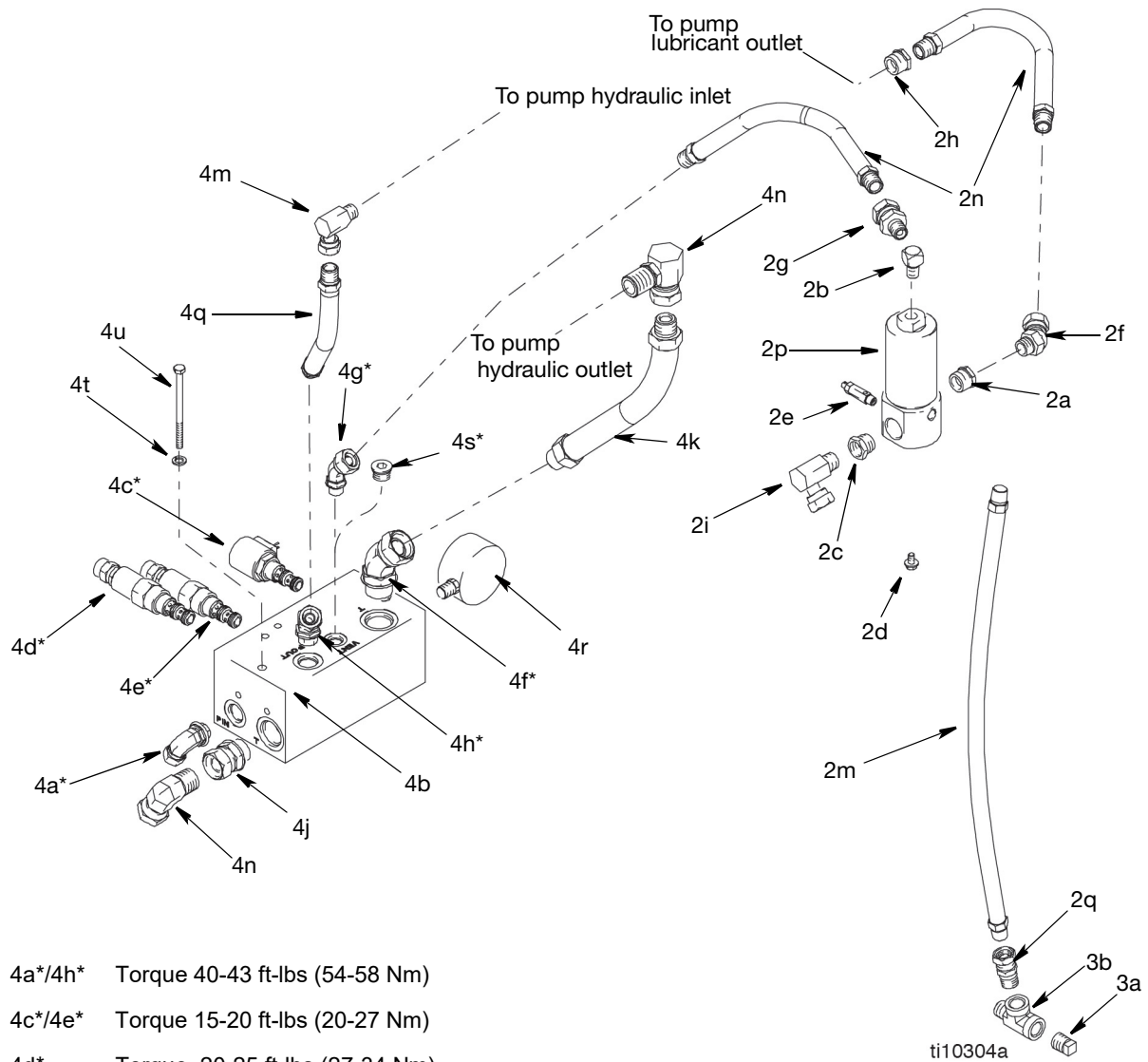

- 4a*/4h* Torque 40-43 ft-lbs (54-58 Nm)
- 4c*/4e* Torque 15-20 ft-lbs (20-27 Nm)
- 4d* Torque 20-25 ft-lbs (27-34 Nm)
- 4f* Torque 68-75 ft-lbs (92-102 Nm)
- 4g* Torque 22-24 ft-lbs (30-33 Nm)
- 4s* Allows user to plug vent line for use in systems without a vent valve

* Lubricate o-ring with oil before installation

Parts List

Model 24Y408: Dyna-Star 10:1 Pump Module, 60# for Single Line, Parallel, Automatic Lubrication Systems

Model 24Y407: Dyna-Star 10:1 Pump Module, 90# for Single Line, Parallel, Automatic Lubrication Systems

Model 25C948: Dyna-Star 10:1 Pump Module, 60# for Single Line, Parallel, Automatic Lubrication Systems with Low Level Indicator

Model 25C949: Dyna-Star 10:1 Pump Module, 90# for Single Line, Parallel, Automatic Lubrication Systems with Low Level Indicator

Ref. No.	Part No.	Description	Qty
1	2008088◆★	PUMP, Dyna-Star 60#, see manual 312350	1
	247443†❖	PUMP, Dyna-Star 120#, see manual 312350	
2	243170	KIT, installation, vent valve	1
2a	100505	BUSHING, pipe	1
2b	100840	ELBOW, street	1
2c	100896	FITTING, bushing, pipe	1
2d		SCREW, cap, hex hd	2
2e	115122	VALVE, pressure relief	1
2f	161889	UNION, adapter	1
2g	157705	UNION, swivel	1
2h	158212	BUSHING	1
2i	155470	UNION, union, swivel, 90 degree	1
2m	194995	HOSE, vent; 1/2 in.	2
2n	238370	HOSE	2
2p	242063	VALVE, vent	1
2q	156684	UNION, adapter	1
3		Reservoir Assembly	
3a	100737	PLUG, pipe	2
3b	108126	TEE, pipe	1
3c		NUT, flanged, hex	6
3d		SCREW, cap, flange head	4
3e	115254	BREATHER	1
3f	194868	GASKET, cover	1
3g	15R105★	PAIL, reservoir, 60#	1
	194907†	PAIL, reservoir, 90#	1
	17L287◆	PAIL reservoir, 60#	1
	17L354❖	PAIL reservoir, 90#	1
3h	16X912	COVER, reservoir	1
3i	104663	PLUG, pipe	1
3j	101864	SCREW, cap	4
3k	15M442	GASKET, pump	1
3l	100214	WASHER, lock	6
4	247538	KIT, installation control module	1
4a	112581	ADAPTER, male	1

Ref. No.	Part No.	Description	Qty
4b	121207	MODULE, hydraulic control	1
4c		VALVE, 3-way solenoid	1
4d		VALVE, flow regulating	1
4e	121206	VALVE, pressure reducing	1
4f	115757	ADAPTER, straight thread	1
4g	115758	ADAPTER, straight thread	1
4h	115760	ADAPTER, straight thread	1
4j	115763	ADAPTER, straight thread	1
4k	115776	HOSE, 3/4 in. X 3/4 in. NPT	1
4m	115829	UNION, swivel, 90 degree	1
4n	160327	UNION, adapter 90 degree	2
4q	238370	HOSE, coupled, 1 ft.	1
4r	802072	GAUGE, pressure	1
4s	108984	PLUG, hollow, hex	1
4t		WASHER, lock	6
4u		SCREW, cap, hex hd	2
5		TEE, pipe	1
6		ADAPTOR	1
7	217430	ADAPTOR	1
8	16V582	AUTO-FILL SHUTOFF	1
9	16V748	DIAPHRAM	1
10	16V396	SEAL, AUTO-FILL SHUTOFF	1
11	16X389	SCREW, cap, button head	2
12	17L392◆❖	Low level sensor	1
12a		Packing, O-ring	1
12b		Sensor, low level	1
12c		ADAPTOR, cover	1

- ★ For Model 24Y408
- † For Model 24Y409
- ◆ For Model 25C948
- ❖ For Model 25C949

* Installation kits for custom user provided lubricant reservoirs not shown.

Technical Data

Pump Module with Auto-Fill Shutoff	US	Metric
Maximum hydraulic input pressure	3500 psi	24.0 MPa, 240 bar
Pump wetted parts	see manual 312350	
Vent valve wetted parts	see manual 309099	
Reservoir wetted parts	steel, buna-n rubber	
Maximum delivery @ 60 cpm	1.1 lb/min, 34.8 in ³ /min	570 cm ³ /min
Regulated hydraulic pressure operating range	250 to 350 psi	1.7 to 2.4 MPa, 17.0 to 24.1 bar
Hydraulic flow rate operating range	0.5 to 3.0 gpm	1.9 to 11.4 liter/min
Maximum hydraulic fluid temperature	200°F	93.33°C
Lubricant outlet pressure range	2500 to 3500 psi	17.0 to 24.0 MPa, 170 to 240 bar
Fill port size - Auto-fill Shutoff	3/8 inch npt (FIG. 2, S, page 7)	
Hydraulic inlet port size	3/8 inch nps swivel (FIG. 9, Y, page 11)	
Hydraulic tank line size	3/4 inch nps swivel (FIG. 9, Z, page 11)	
Lubricant outlet port size	1/2 inch nps swivel (FIG. 2 U, page 7)	
Grease capacity		
Model 24Y407, 25C949	90 lb.	41 kg
Model 24Y408, 25C948	60 lb.	27 kg
Mounting holes for pump module	six, 7/16 inch holes on 13 7/8 inch bolt circle	
Reservoir diameter	12 3/4 inch	324 mm
Pump module height		
Model 24Y407, 25C949	42.75 inch	1086 mm
Model 24Y408, 25C948	35.15 inch	893 mm
Electrical requirements	Timed 24 VDC signal	
Electrical power requirements	14.7 Watts	
Filtration (hydraulic fluid)	10μ (microns) or better	
Sound Pressure*	77 dB(A)	
*Sound pressure reading taken with pump operating at 66 cycles per minute. Sound pressure measured per CAGI-PNEUROP, 1971.		

Dimensions

Model 24Y408
Model 25C948

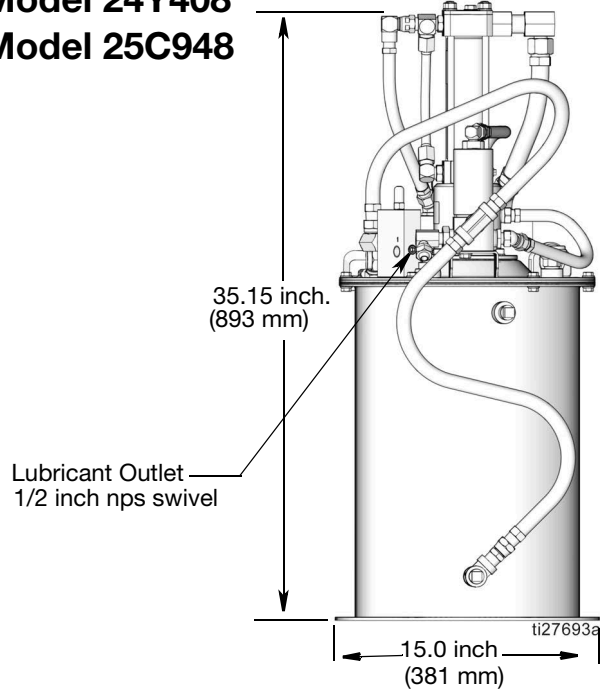

Mounting Diagram

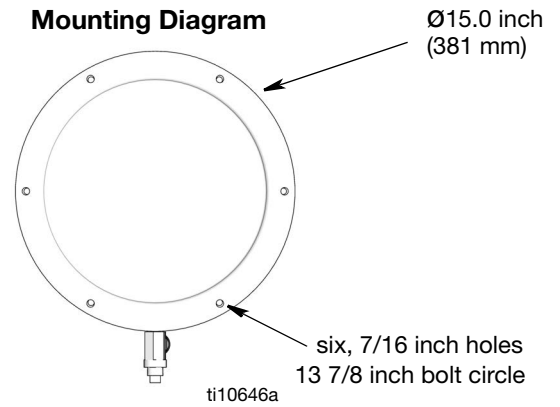

Model 24Y407
Model 25C949

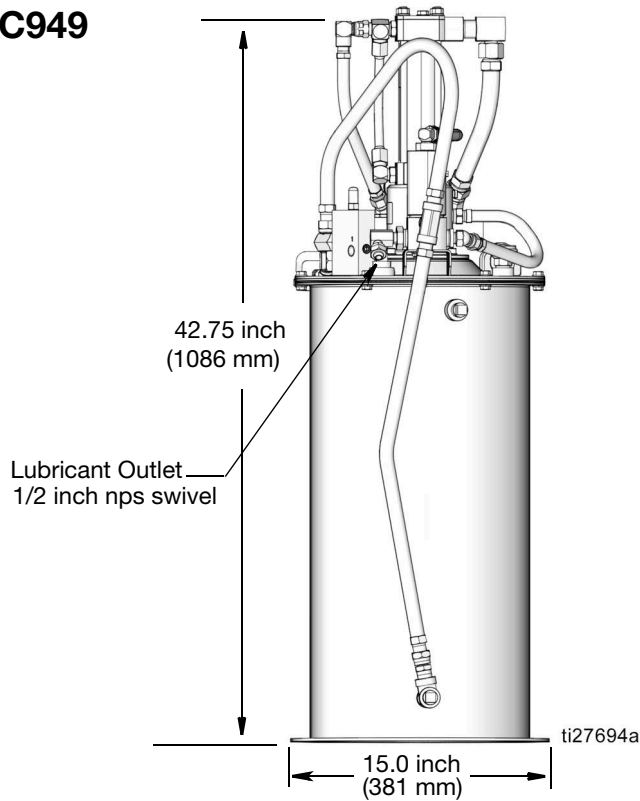

Mounting Diagram

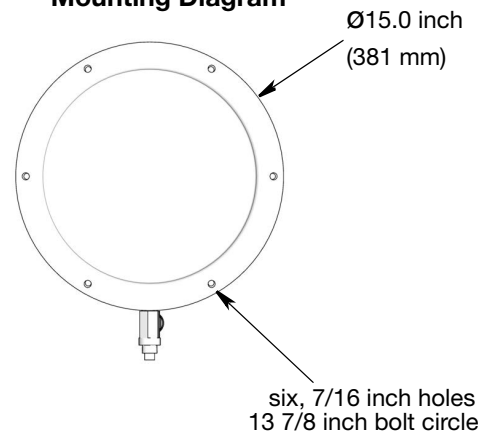

Graco Standard Warranty

Graco warrants all equipment referenced in this document which is manufactured by Graco and bearing its name to be free from defects in material and workmanship on the date of sale to the original purchaser for use. With the exception of any special, extended, or limited warranty published by Graco, Graco will, for a period of twelve months from the date of sale, repair or replace any part of the equipment determined by Graco to be defective. This warranty applies only when the equipment is installed, operated and maintained in accordance with Graco's written recommendations.

This warranty does not cover, and Graco shall not be liable for general wear and tear, or any malfunction, damage or wear caused by faulty installation, misapplication, abrasion, corrosion, inadequate or improper maintenance, negligence, accident, tampering, or substitution of non-Graco component parts. Nor shall Graco be liable for malfunction, damage or wear caused by the incompatibility of Graco equipment with structures, accessories, equipment or materials not supplied by Graco, or the improper design, manufacture, installation, operation or maintenance of structures, accessories, equipment or materials not supplied by Graco.

This warranty is conditioned upon the prepaid return of the equipment claimed to be defective to an authorized Graco distributor for verification of the claimed defect. If the claimed defect is verified, Graco will repair or replace free of charge any defective parts. The equipment will be returned to the original purchaser transportation prepaid. If inspection of the equipment does not disclose any defect in material or workmanship, repairs will be made at a reasonable charge, which charges may include the costs of parts, labor, and transportation.

THIS WARRANTY IS EXCLUSIVE, AND IS IN LIEU OF ANY OTHER WARRANTIES, EXPRESS OR IMPLIED, INCLUDING BUT NOT LIMITED TO WARRANTY OF MERCHANTABILITY OR WARRANTY OF FITNESS FOR A PARTICULAR PURPOSE.

Graco's sole obligation and buyer's sole remedy for any breach of warranty shall be as set forth above. The buyer agrees that no other remedy (including, but not limited to, incidental or consequential damages for lost profits, lost sales, injury to person or property, or any other incidental or consequential loss) shall be available. Any action for breach of warranty must be brought within two (2) years of the date of sale.

GRACO MAKES NO WARRANTY, AND DISCLAIMS ALL IMPLIED WARRANTIES OF MERCHANTABILITY AND FITNESS FOR A PARTICULAR PURPOSE, IN CONNECTION WITH ACCESSORIES, EQUIPMENT, MATERIALS OR COMPONENTS SOLD BUT NOT MANUFACTURED BY GRACO. These items sold, but not manufactured by Graco (such as electric motors, switches, hose, etc.), are subject to the warranty, if any, of their manufacturer. Graco will provide purchaser with reasonable assistance in making any claim for breach of these warranties.

In no event will Graco be liable for indirect, incidental, special or consequential damages resulting from Graco supplying equipment hereunder, or the furnishing, performance, or use of any products or other goods sold hereto, whether due to a breach of contract, breach of warranty, the negligence of Graco, or otherwise.

FOR GRACO CANADA CUSTOMERS

The Parties acknowledge that they have required that the present document, as well as all documents, notices and legal proceedings entered into, given or instituted pursuant hereto or relating directly or indirectly hereto, be drawn up in English. Les parties reconnaissent avoir convenu que la rédaction du présente document sera en Anglais, ainsi que tous documents, avis et procédures judiciaires exécutés, donnés ou intentés, à la suite de ou en rapport, directement ou indirectement, avec les procédures concernées.

Graco Information

For the latest information about Graco products, visit www.graco.com.

For patent information, see www.graco.com/patents.

TO PLACE AN ORDER, contact your Graco distributor or call to identify the nearest distributor.

Phone: 612-623-6928 or Toll Free: 1-800-533-9655, Fax: 612-378-3590

*All written and visual data contained in this document reflects the latest product information available at the time of publication.
Graco reserves the right to make changes at any time without notice.*

Original instructions. This manual contains English. MM 3A3429

Graco Headquarters: Minneapolis

International Offices: Belgium, China, Japan, Korea

GRACO INC. AND SUBSIDIARIES • P.O. BOX 1441 • MINNEAPOLIS MN 55440-1441 • USA
Copyright 2016, Graco Inc. All Graco manufacturing locations are registered to ISO 9001.

www.graco.com

Revision E, November 2024