

LineLazer V 250SPS and 250DC Self-Propelled Line Striper

3A3394L

EN

For the application of line striping materials. For professional use only. For outdoor use only. Not for use in explosive atmospheres or hazardous locations.

Maximum Operating Speed: 10 mph (16 kph)

Maximum Operating Pressure: 3300 psi (22.8 MPa, 228 bar)



IMPORTANT SAFETY INSTRUCTIONS

Read all warnings and instructions in this manual and in related manuals.
Be familiar with the controls and the proper usage of the equipment.
Save these instructions.

Model	Guns	Pressurized Bead System	Description
17H471 / 17H471V	2	No	LLV 250DC
17H472	3	No	LLV 250DC
17H473	2	Yes - 2 Tank	LLV 250DC
25P365	2	Yes - 2 Tank	LLV 250DC
17H474 / 17H474V	3	Yes - 2 Tank	LLV 250DC
17H466	1	No	LLV 250SPS
17H467 / 17H467V	2	No	LLV 250SPS
17H468	1	Yes - 1 Tank	LLV 250SPS
17J951 / 17J951V	2	Yes - 1 Tank	LLV 250SPS
17H469	2	Yes - 2 Tank	LLV 250SPS

Related Manuals:	
3A3393	Operation
311254	Gun
309277	Pump
3A3428	Auto-Layout Applications Methods
332230	Pressurized Bead System (PBS)
3A6981	Steering Cable Replacement
3B0122	Gallon Counter Replacement

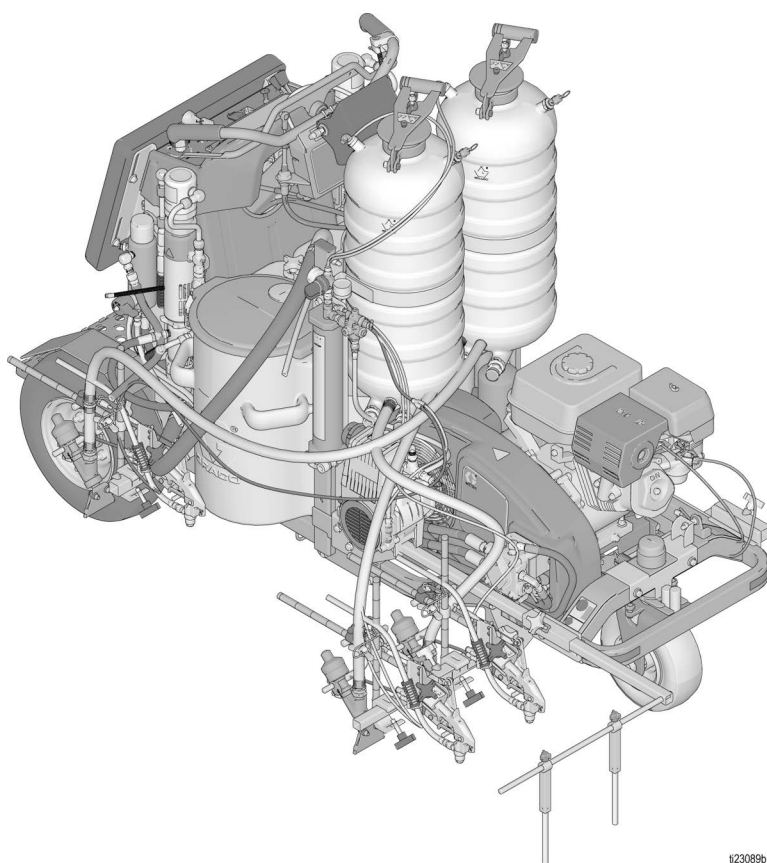

t23089b













*Use only genuine Graco replacement parts.
The use of non-Graco replacement parts may void warranty.*

Contents









Warnings	3	Front Wheel Replacement	41
Important Laser Information for Units with Laser Option 6		Removal	41
Component Identification (LLV 250DC Shown)	7	Installation	41
Component Identification (Controls)	8	Parking Brake Service	42
Grounding Procedure		Removal	42
(For Flammable Materials Only)	9	Installation	42
Pressure Relief Procedure	9	Rear Wheel and Wheel Motors	43
Ground Drive Belt Replacement	10	Rear Wheel Removal	43
Removal	10	Rear Wheel Installation	43
Installation	10	Wheel Motor Removal	43
Oil Reservoir Belt Replacement	11	Wheel Motor Installation	44
Removal	11	Wheel Sensor Replacement	44
Installation	11	Recycling and Disposal	46
Hydraulic System Purging	12	Rechargeable Battery Disposal	46
Ground Drive Pump Replacement	14	End of Product Life	46
Removal	14	Troubleshooting	47
Installation	14	General	47
Oil Reservoir Pump Replacement	15	Notes	51
Removal	15	Parts	52
Installation	16	Parts List	53
Hydraulic Gun Manifold Replacement	18	Parts	54
Removal	18	Parts List	55
Installation	19	Parts (24U235/24U235V Control Panel)	56
Paint Pump Replacement	21	Parts List	57
Removal	21	Parts	58
Installation	21	Parts List	59
Hydraulic Motor Replacement	22	Parts	60
Removal	22	Parts List	61
Installation	22	Parts (Front Wheel)	62
Clutch Replacement	23	Series A	62
Removal	23	Series B	62
Installation	24	Parts List - Series A	63
Engine Replacement	26	Parts List - Series B	63
Removal (Honda)	26	Parts (Gun Mount)	64
Installation (Honda)	27	Parts List	65
Removal (Vanguard)	28	Parts	66
Installation (Vanguard)	29	Parts List	67
Touch-Pad Display	30	Parts (Pump)	68
Control Board Replacement	31	Parts List (Pump)	69
Removal	31	Wiring Diagram (Honda)	70
Installation	32	Wiring Parts List (Honda)	71
Battery Replacement	34	Wiring Diagram (Vanguard)	72
Removal	34	Wiring Parts List (Vanguard)	73
Installation	34	Hydraulic Diagram	74
Fuse Replacement	35	Hydraulic Parts List	75
Forward/Reverse Cable Replacement	36	California Proposition 65	76
Removal	36	Graco Standard Warranty	77
Installation	37		
Steering Cable Replacement	38		
Removal	38		
Installation	40		

Warnings

The following warnings are for the setup, use, grounding, maintenance, and repair of this equipment. The exclamation point symbol alerts you to a general warning and the hazard symbols refer to procedure-specific risks. When these symbols appear in the body of this manual or on warning labels, refer back to these Warnings. Product-specific hazard symbols and warnings not covered in this section may appear throughout the body of this manual where applicable.





 <h1 style="margin: 0;">WARNING</h1>	
 	<p>TRAFFIC HAZARD</p> <p>Being struck by other vehicles may result in serious injury or death.</p> <ul style="list-style-type: none"> • Do not operate in traffic. • Use appropriate traffic control in all traffic areas. • Follow local highway and transportation regulations for traffic control (for example: Manual on Uniform Traffic Control Devices, U.S. Department of Transportation).
    	<p>FIRE AND EXPLOSION HAZARD</p> <p>Flammable fumes, such as solvent and paint fumes, in work area can ignite or explode. Paint or solvent flowing through the equipment can cause static sparking. To help prevent fire and explosion:</p> <ul style="list-style-type: none"> • Use equipment only in well ventilated area. • Do not fill fuel tank while engine is running or hot; shut off engine and let it cool. Fuel is flammable and can ignite or explode if spilled on hot surface. • Eliminate all ignition sources; such as pilot lights, cigarettes, portable electric lamps, and plastic drop cloths (potential static arc). • Ground all equipment in the work area. See Grounding instructions. • Never spray or flush solvent at high pressure. • Keep work area free of debris, including solvent, rags and gasoline. • Do not plug or unplug power cords, or turn power or light switches on or off when flammable fumes are present. • Use only grounded hoses. • Hold gun firmly to side of grounded pail when triggering into pail. Do not use pail liners unless they are anti-static or conductive. • Stop operation immediately if static sparking occurs or you feel a shock. Do not use equipment until you identify and correct the problem. • Keep a working fire extinguisher in the work area.
    	<p>SKIN INJECTION HAZARD</p> <p>High-pressure spray is able to inject toxins into the body and cause serious bodily injury. In the event that injection occurs, get immediate surgical treatment.</p> <ul style="list-style-type: none"> • Do not aim the gun at, or spray any person or animal. • Keep hands and other body parts away from the discharge. For example, do not try to stop leaks with any part of the body. • Always use the nozzle tip guard. Do not spray without nozzle tip guard in place. • Use Graco nozzle tips. • Use caution when cleaning and changing nozzle tips. In the case where the nozzle tip clogs while spraying, follow the Pressure Relief Procedure for turning off the unit and relieving the pressure before removing the nozzle tip to clean. • Equipment maintains pressure after power is shut off. Do not leave the equipment energized or under pressure while unattended. Follow the Pressure Relief Procedure when the equipment is unattended or not in use, and before servicing, cleaning, or removing parts. • Check hoses and parts for signs of damage. Replace any damaged hoses or parts. • This system is capable of producing 3300 psi. Use Graco replacement parts or accessories that are rated a minimum of 3300 psi. • Always engage the trigger lock when not spraying. Verify the trigger lock is functioning properly. • Verify that all connections are secure before operating the unit. • Know how to stop the unit and bleed pressure quickly. Be thoroughly familiar with the controls.

! WARNING





	<p>CARBON MONOXIDE HAZARD</p> <p>Exhaust contains poisonous carbon monoxide, which is colorless and odorless. Breathing carbon monoxide can cause death.</p> <ul style="list-style-type: none"> Do not operate in an enclosed area.
 	<p>EQUIPMENT MISUSE HAZARD</p> <p>Misuse can cause death or serious injury.</p> <ul style="list-style-type: none"> Do not operate the unit when fatigued or under the influence of drugs or alcohol. Do not exceed the maximum working pressure or temperature rating of the lowest rated system component. See Technical Data in all equipment manuals. Use fluids and solvents that are compatible with equipment wetted parts. See Technical Data in all equipment manuals. Read fluid and solvent manufacturer's warnings. For complete information about your material, request Safety Data Sheet (SDS) from distributor or retailer. Do not leave the work area while equipment is energized or under pressure. Turn off all equipment and follow the Pressure Relief Procedure when equipment is not in use. Check equipment daily. Repair or replace worn or damaged parts immediately with genuine manufacturer's replacement parts only. Do not alter or modify equipment. Alterations or modifications may void agency approvals and create safety hazards. Make sure all equipment is rated and approved for the environment in which you are using it. Use equipment only for its intended purpose. Call your distributor for information. Route hoses and cables away from traffic areas, sharp edges, moving parts, and hot surfaces. Do not kink or over bend hoses or use hoses to pull equipment. Keep children and animals away from work area. Comply with all applicable safety regulations.
	<p>PRESSURIZED ALUMINUM PARTS HAZARD</p> <p>Use of fluids that are incompatible with aluminum in pressurized equipment can cause serious chemical reaction and equipment rupture. Failure to follow this warning can result in death, serious injury, or property damage.</p> <ul style="list-style-type: none"> Do not use 1,1,1-trichloroethane, methylene chloride, other halogenated hydrocarbon solvents or fluids containing such solvents. Do not use chlorine bleach. Many other fluids may contain chemicals that can react with aluminum. Contact your material supplier for compatibility.
 	<p>MOVING PARTS HAZARD</p> <p>Moving parts can pinch, cut or amputate fingers and other body parts.</p> <ul style="list-style-type: none"> Keep clear of moving parts. Do not operate equipment with protective guards or covers removed. Pressurized equipment can start without warning. Before checking, moving, or servicing equipment, follow the Pressure Relief Procedure and disconnect all power sources.
 	<p>ENTANGLEMENT HAZARD</p> <p>Rotating parts can cause serious injury.</p> <ul style="list-style-type: none"> Keep clear of moving parts. Do not operate equipment with protective guards or covers removed. Do not wear loose clothing, jewelry or long hair while operating equipment. Equipment can start without warning. Before checking, moving, or servicing equipment, follow the Pressure Relief Procedure and disconnect all power sources.



WARNING

	<p>TOXIC FLUID OR FUMES HAZARD</p> <p>Toxic fluids or fumes can cause serious injury or death if splashed in the eyes or on skin, inhaled, or swallowed.</p> <ul style="list-style-type: none"> • Read Safety Data Sheet (SDS) to know the specific hazards of the fluids you are using. • Store hazardous fluid in approved containers, and dispose of it according to applicable guidelines.
	<p>BURN HAZARD</p> <p>Equipment surfaces and fluid that's heated can become very hot during operation. To avoid severe burns:</p> <ul style="list-style-type: none"> • Do not touch hot fluid or equipment.
	<p>PERSONAL PROTECTIVE EQUIPMENT</p> <p>Wear appropriate protective equipment when in the work area to help prevent serious injury, including eye injury, hearing loss, inhalation of toxic fumes, and burns. This protective equipment includes but is not limited to:</p> <ul style="list-style-type: none"> • Protective eyewear, and hearing protection. • Respirators, protective clothing, and gloves as recommended by the fluid and solvent manufacturer.
	<p>BATTERY HAZARD</p> <p>The battery may leak, explode, cause burns, or cause an explosion if mishandled. Contents of an open battery can cause severe irritation and/or chemical burns. If on skin, wash with soap and water. If in eyes, flush with water for at least 15 minutes and get immediate medical attention.</p> <ul style="list-style-type: none"> • Only use the battery type specified for use with the equipment. See Technical Data. • Replace battery only in well-ventilated area and away from flammable or combustible materials, including paints and solvents. • Do not dispose of battery in fire or heat above 50°C (122°F). The battery is capable of exploding. • Do not throw into fire. • Do not expose battery to water or rain. • Do not disassemble, crush, or penetrate the battery. • Do not use or charge a battery that is cracked or damaged. • Follow local ordinances and/or regulations for disposal.

Important Laser Information for Units with Laser Option

 WARNING	
	<p>LASER LIGHT HAZARD: AVOID DIRECT EYE CONTACT</p> <p>Eye exposure to Class IIIa/3R levels of laser light can potentially present an eye (retinal) injury hazard, including spot blindness or other retinal injury. To avoid direct eye exposure:</p> <ul style="list-style-type: none"> • Never look directly in to a laser beam or point the beam into the eyes of others, even at long distances. • Never shine the laser at mirror like surfaces which can cause specular reflections of the beam. • Always set the laser at a height and angle that prevents the beam from shining into people's eyes. • Immediately terminate laser emissions if personnel, animals or reflective objects approach the beam. • Always turn off laser when unattended. • Do not remove any warning labels from the laser. • Only properly trained laser operators are to use this product. • Never allow beams to be aimed toward traffic, vehicles, or heavy equipment. Even when not damaging at long distances, the high brightness of lasers can distract or disrupt vehicle operations. • Never point a laser at an aircraft or law enforcement personnel. This is considered a felony in most locations, with the possibility of jail time, heavy fines or both. • Do not disassemble laser product. Return to factory for all service procedures. • Laser must be turned OFF when cleaning the lens, so as not to create unwanted laser refraction.
	<p>LASER RADIATION HAZARD</p> <p>Use of controls or adjustments or performance of procedures other than those specified herein may result in hazardous radiation exposure.</p> <ul style="list-style-type: none"> • Do not attempt to open or disassemble the laser housing under any circumstances. Doing so may cause exposure to potentially hazardous levels of laser radiation. • No serviceable parts within. Unit is factory sealed.
	<p>FIRE AND EXPLOSION HAZARD</p> <p>Connecting directly to a generator source can create a short or sparking under certain conditions.</p> <ul style="list-style-type: none"> • Only connect GL1700 to a dedicated 12 volt DC battery source.

Component Identification (LLV 250DC Shown)

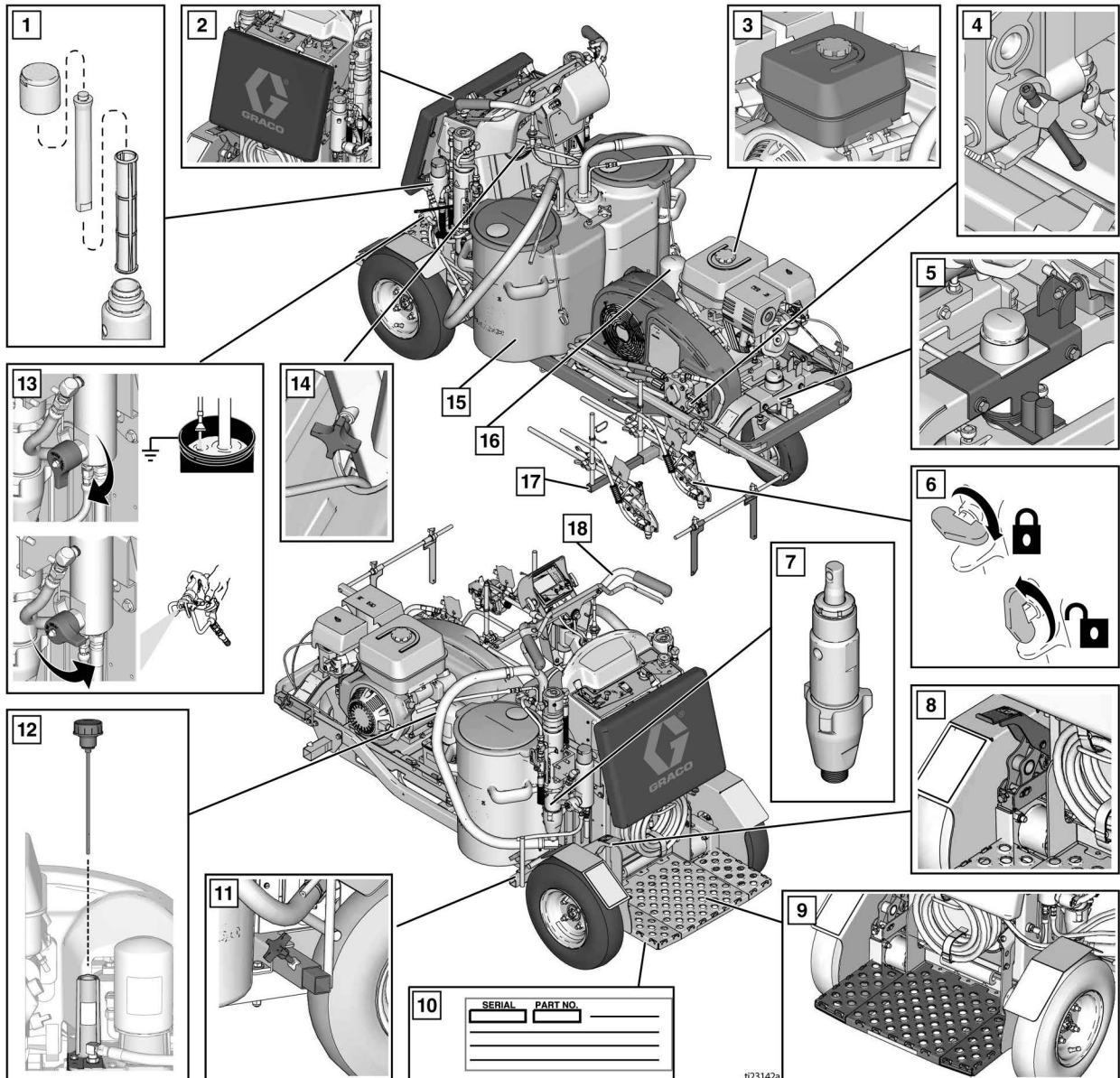

1	Paint filter, both sides
2	Adjustable pad
3	Engine fuel cap
4	Wheel motor bypass valve
5	Straight line adjuster
6	Gun trigger lock
7	Displacement pump, both sides
8	Brake
9	Operator platform

10	Serial label under operator platform
11	Rear gun arm mount, both sides
12	Hydraulic fill cap/dipstick
13	Prime/drain valve, both sides
14	Handle bar height adjustment knob
15	Two paint hoppers (15 gallon/56 liter)
16	Hydraulic oil filter
17	Front gun mount, both sides
18	Steering handle

*LLV 250SPS has only 1 paint hopper and 1 pump.

Component Identification (Controls)

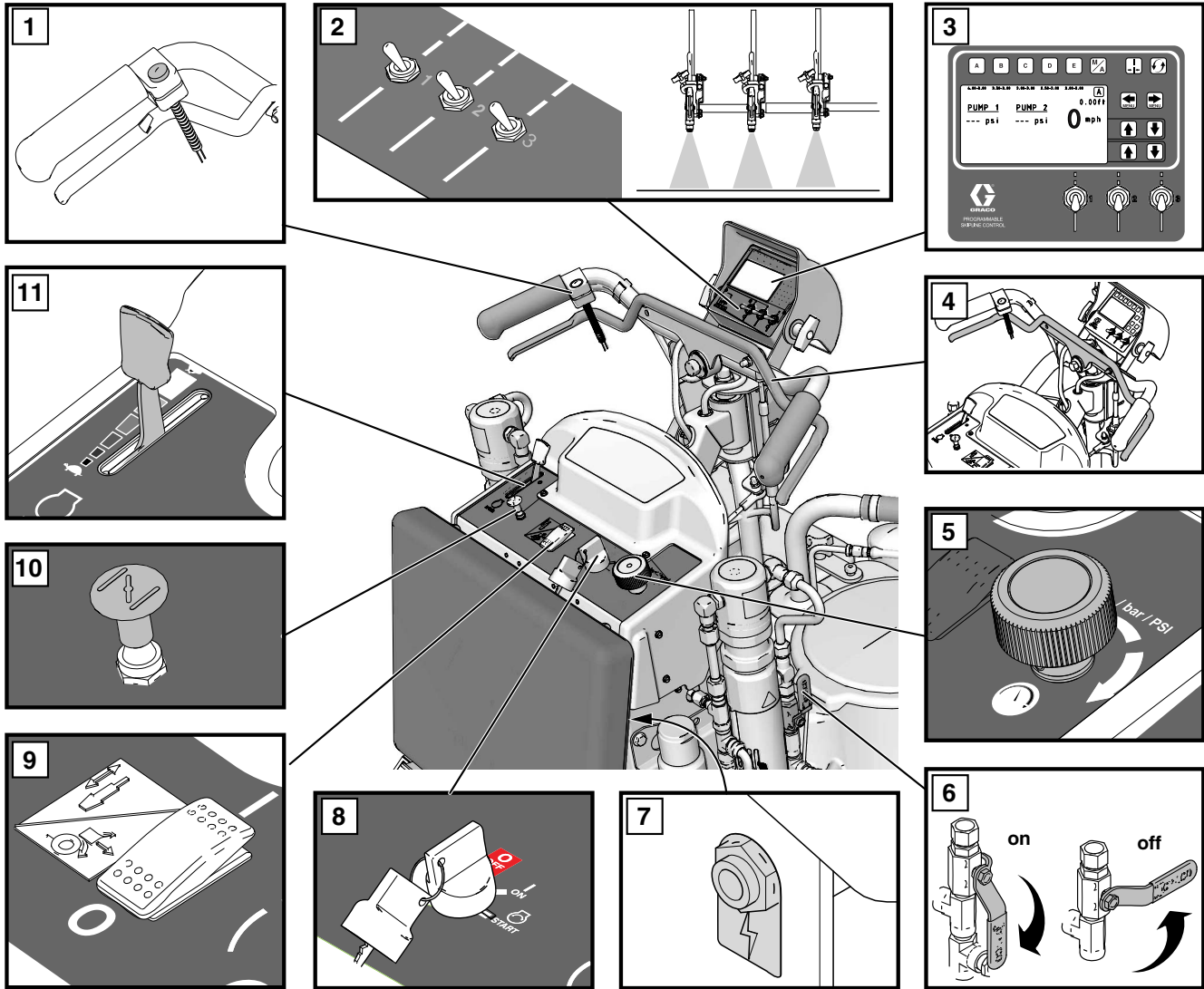

ti23143a

1	Gun trigger control
2	Gun 1, 2, 3 selector
3	Display
4	Forward/reverse lever
5	Pressure control
6	Hydraulic pump valve, both sides

7	12V accessory jack
8	Engine key switch, OFF - ON - Start
9	Engine clutch switch
10	Engine choke
11	Engine throttle

Grounding Procedure (For Flammable Materials Only)

--	--	--	--	--

This equipment must be grounded to reduce the risk of static sparking. Static sparking can cause fumes to ignite or explode. Grounding provides an escape wire for the electric current.

1. Position striper so that the tires are not on pavement.
2. Striper is shipped with a grounding clamp. Grounding clamp must attach to grounded object (e.g. metal sign post).

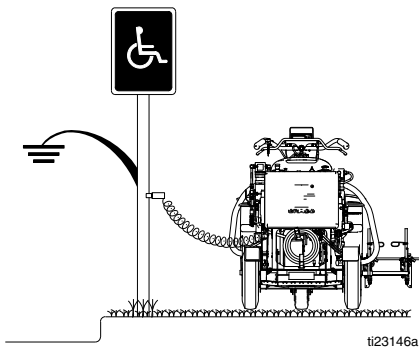

Pressure Relief Procedure

This equipment stays pressurized until pressure is manually relieved. To help prevent serious injury from pressurized fluid, such as skin injection, splashing fluid and moving parts, follow the Pressure Relief Procedure when you stop dispensing and before cleaning, checking, or servicing the equipment.

1. Perform **Grounding Procedure** if using flammable materials.

2. Set pump valve(s) to **OFF** (250SPS has one pump valve; 250DC has two pump valves). Turn engine **OFF**.

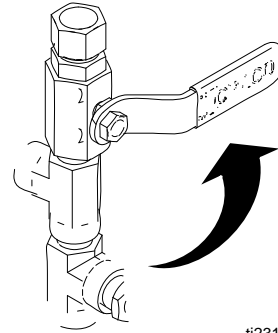

3. Turn pressure control to lowest setting. Trigger all guns to relieve pressure.

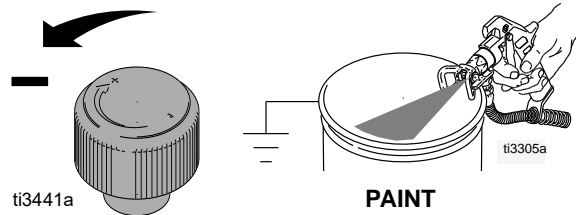

4. Engage all gun trigger locks. Turn prime valve(s) down (250SPS has one prime valve; 250DC has two prime valves).

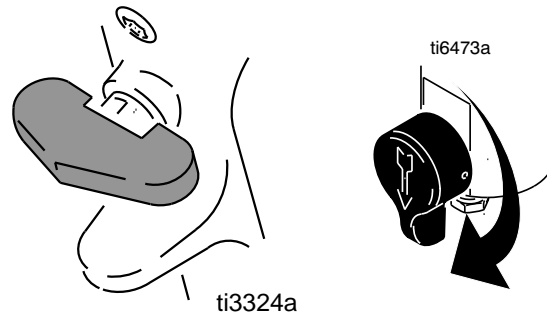

5. If you suspect the spray tip or hose is clogged or that pressure has not been fully relieved:
 - a. **VERY SLOWLY** loosen the tip guard retaining nut or the hose end coupling to relieve pressure gradually.
 - b. Loosen the nut or coupling completely.
 - c. Clear the obstruction in the hose or tip.

Ground Drive Belt Replacement

Removal



1. If equipped with a Pressurized Bead System, remove pressurized bead tanks and compressor, see Pressurized Bead System manual 332230.
2. Loosen four screws and remove belt cover.

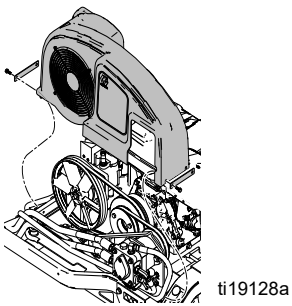

3. Loosen two hold-down bolts.

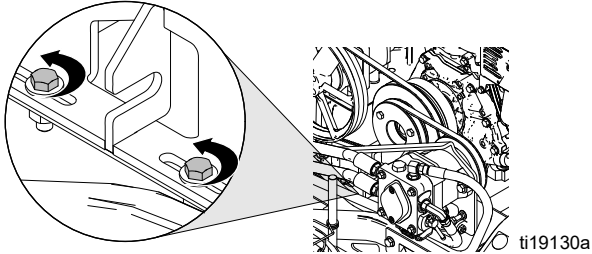

4. Loosen tension bolt to bring two pulleys closer together to create slack in the belt.

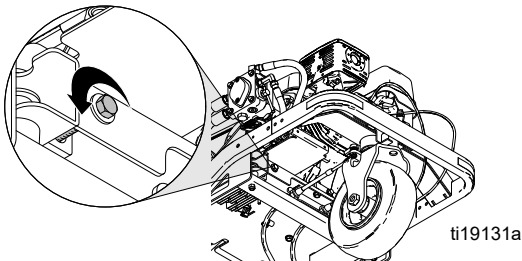

5. Remove belt.

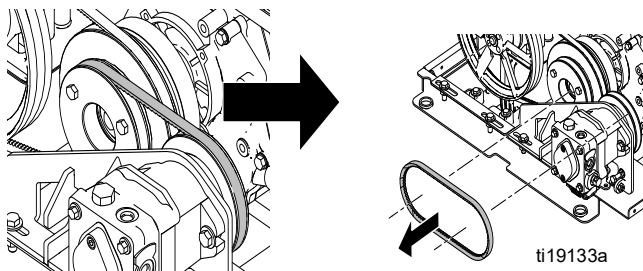

Installation

1. Install belt onto pulleys.

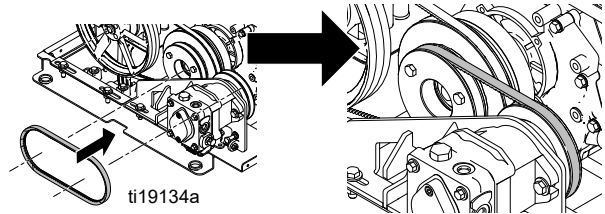

2. Tighten tensioning bolt to move two pulleys apart and tighten belt to proper tension (see table).

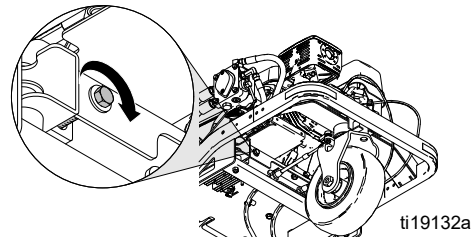

Ground Drive Belt Tension Recommendations		
New Belt	Tension	53 +/- 2 Lbf (236 +/- 9 N)
	Frequency	167 +/- 3 Hz
Used Belt	Tension	45 +/- 2 Lbf (200 +/- 9 N)
	Frequency	155 +/- 3 Hz

Gates Sonic Tension Meter

Settings: M = MASS = 85 g/m

W = # of belts = 1

S = Span = 157 mm

3. Install mounting plate and tighten two hold-down bolts.

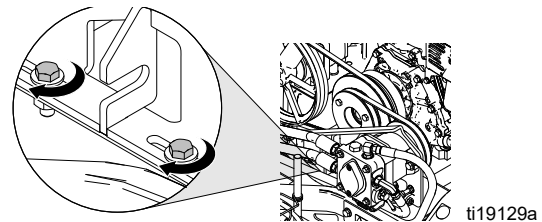

4. Replace belt cover and tighten four screws.

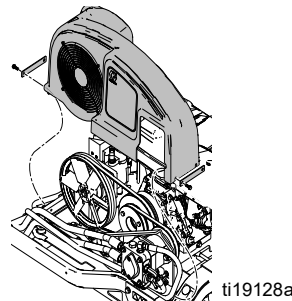

5. If equipped with a Pressurized Bead System, install pressurized bead tanks and compressor, see Pressurized Bead System manual 332230.

Oil Reservoir Belt Replacement



Removal

NOTE: Ground drive belt must be removed before oil reservoir belt can be replaced, see **Ground Drive Belt Replacement**, page 10.

1. Loosen four hold-down bolts.

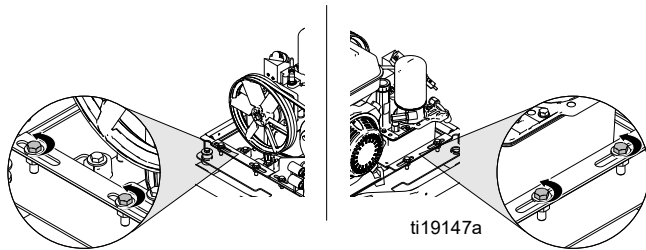

2. Loosen two adjustment bolts to bring pulleys closer together to create slack in the belt.

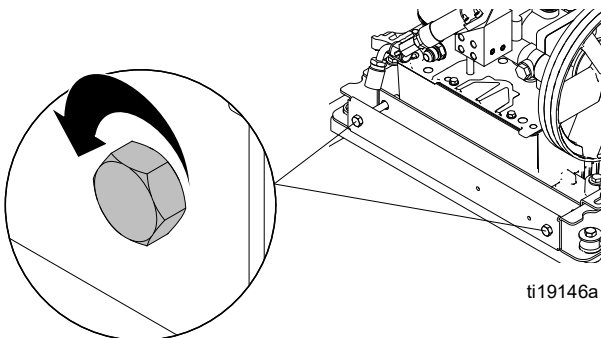

3. Remove belt.

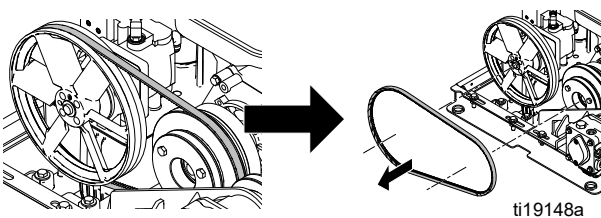

Installation

1. Replace belt.

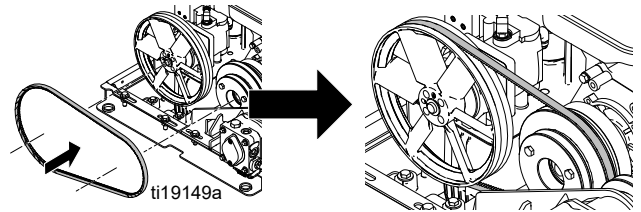

2. Tighten two adjustment bolts evenly and maintain belt alignment. Tighten belt to proper tension (see table).

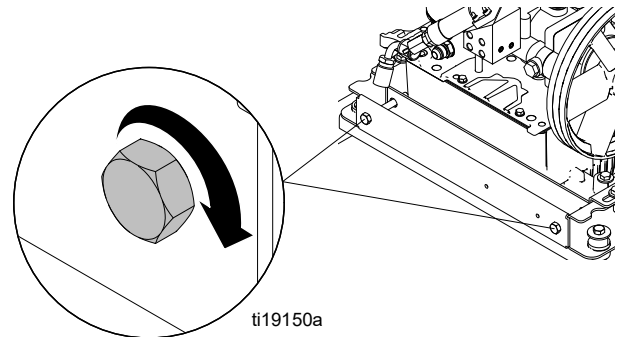

Oil Reservoir Belt Tension Recommendations		
New Belt	Tension	55 +/- 2 Lbf (245 +/- 9 N)
	Frequency	114 +/- 2 Hz
Used Belt	Tension	48 +/- 2 Lbf (214 +/- 9 N)
	Frequency	106 +/- 2 Hz

Gates Sonic Tension Meter

Settings: M = MASS = 85 g/m

W = # of belts = 1

S = Span = 236 mm

3. Tighten four hold-down bolts.

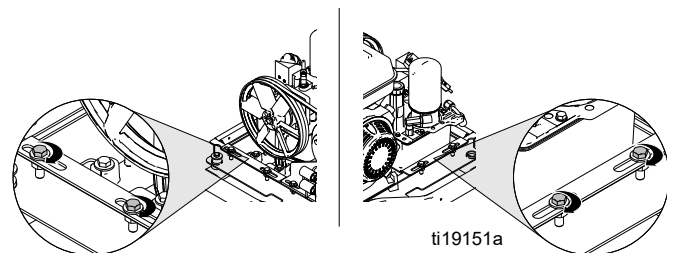

4. Install **Ground Drive Belt** and tighten to proper tension, see **Ground Drive Belt Replacement**, page 10.

Hydraulic System Purging

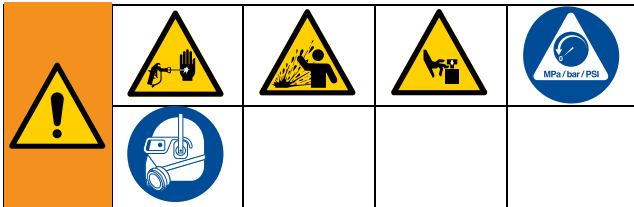

This equipment stays pressurized until pressure is manually relieved. To help prevent serious injury from pressurized fluid, such as skin injection, splashing fluid and moving parts, follow the Pressure Relief Procedure when you stop dispensing and before cleaning, checking, or servicing the equipment.

Follow this procedure after replacing any hydraulic component other than the hydraulic gun manifold which is self-purging.

1. Perform **Pressure Relief Procedure**, page 9.
2. Set LineStriper on blocks so wheels are off ground.

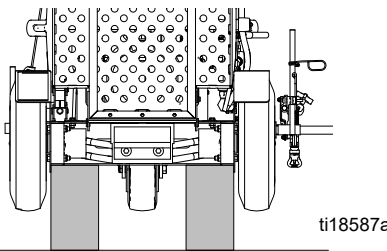

3. Fill oil reservoir to "Full" range.

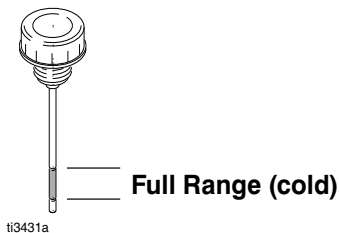

4. Make sure drive wheel release is closed (+).

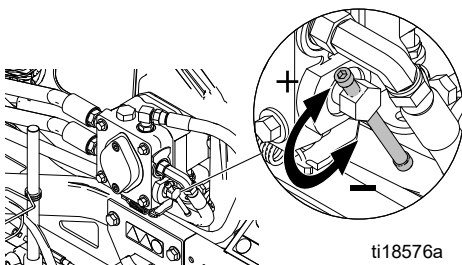

5. Start engine and run at low speed.

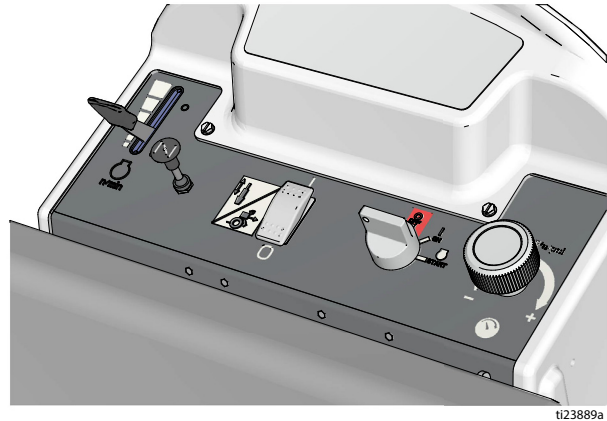

6. Turn on the Main Power Switch to engage clutch.

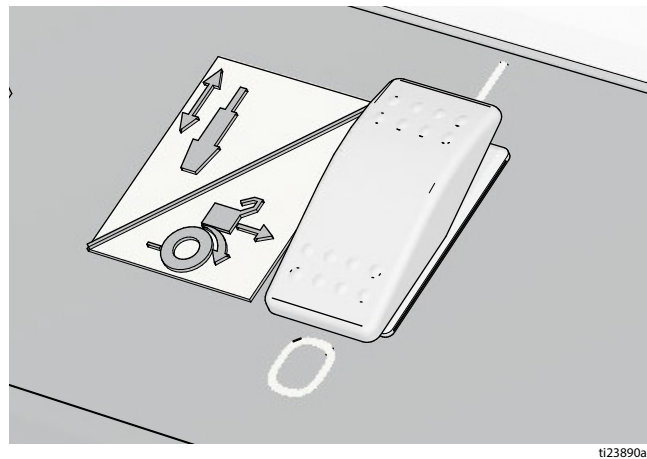

7. Slowly pull forward/reverse control lever in forward and reverse directions 10 times.

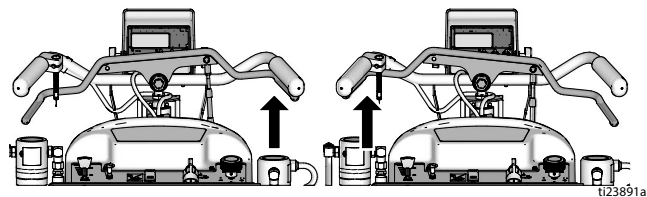

NOTE: Both rear wheels should turn in the correct direction. If one wheel is not turning, carefully restrain the spinning wheel to purge out the wheel that is not turning.

- Turn the prime valve down and open the hydraulic pump valve. Allow the paint pump to stroke 10 times and then close the hydraulic pump valve.

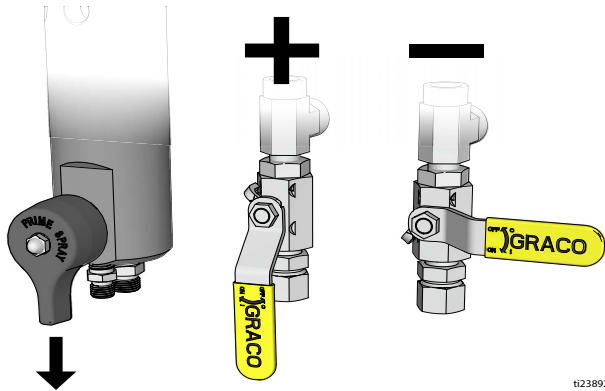

- Repeat step 8 for the other pump.
- The hydraulic gun manifold is self-purging.
- Use the key switch to turn engine off. Check oil level. Top off to "Full" range.

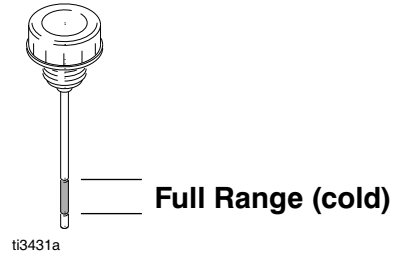

Ground Drive Pump Replacement

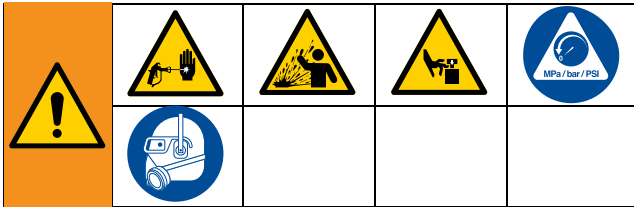

This equipment stays pressurized until pressure is manually relieved. To help prevent serious injury from pressurized fluid, such as skin injection, splashing fluid and moving parts, follow the Pressure Relief Procedure when you stop dispensing and before cleaning, checking, or servicing the equipment.

Removal

1. Perform **Pressure Relief Procedure**, page 9.
2. Remove ground drive belt, see **Ground Drive Belt Replacement**, page 10.
3. Use allen wrench to remove two set screws (71) from pulley (64).
4. Slide pulley (64) off shaft and save key (60).

5. Disconnect all fittings and hoses from pump (63).

NOTE: Oil will spill out of hoses. Have rags and waste pail nearby.

6. Remove nut (3) and disconnect tie rod (40) underneath pump (63).
7. Remove two mounting bolts (82) and washers (55) to remove pump (63) from bracket.

Installation

1. Insert pump (63) into bracket (62) and install two mounting bolts (82) and washers (55).
2. Install tie rod (40) with nut (3) to lever underneath pump (63).
3. Connect all fittings and hoses to pump (63).
4. Install key (60) onto pump shaft and slide pulley (64) onto shaft.
5. Align pulley to outer clutch groove and tighten two set screws (71).
6. Install ground drive belt and tighten to proper tension, see **Ground Drive Belt Replacement**, page 10.
7. Purge Hydraulic System see, **Hydraulic System Purging**, page 12.

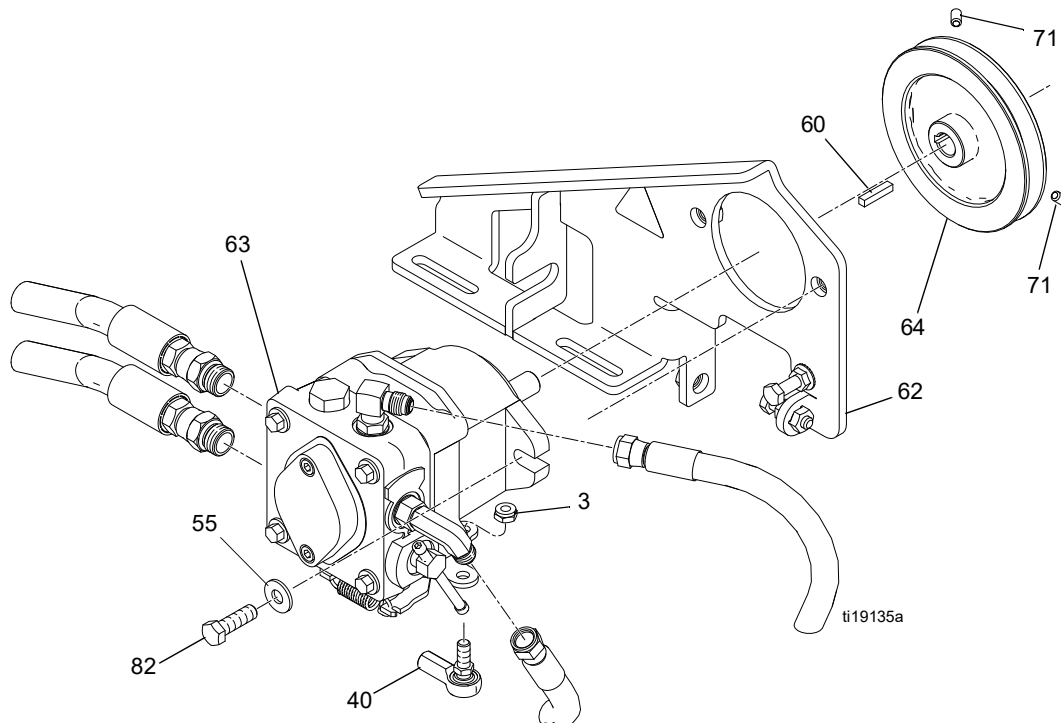

Oil Reservoir Pump Replacement

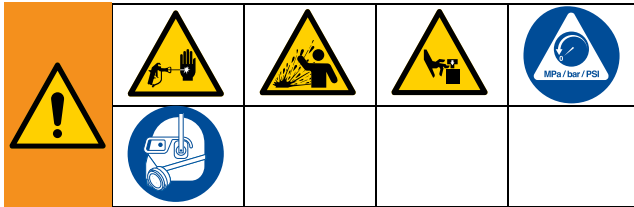

This equipment stays pressurized until pressure is manually relieved. To help prevent serious injury from pressurized fluid, such as skin injection, splashing fluid and moving parts, follow the Pressure Relief Procedure when you stop dispensing and before cleaning, checking, or servicing the equipment.

Removal

1. Perform **Pressure Relief Procedure**, page 9.
2. Remove belt cover, see **Oil Reservoir Belt Replacement**, page 11.
3. Remove oil filter and disconnect five hydraulic hoses from oil reservoir.

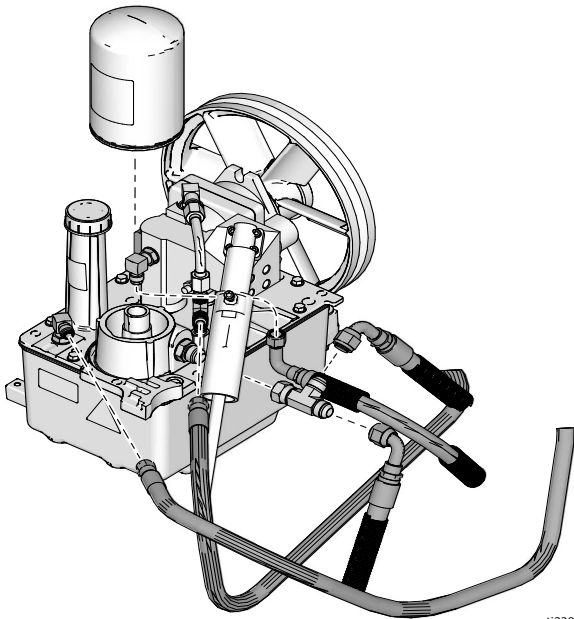

ti23901a

4. Loosen nut and slide cable sleeve down to gain access to the two cable set screws.

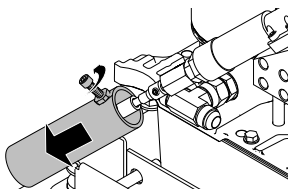

ti19144a

3A3394L

5. Loosen two set screws and cable.

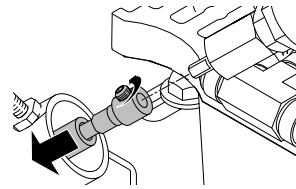

ti19142a

6. Remove eight screws and oil reservoir cover with pump.

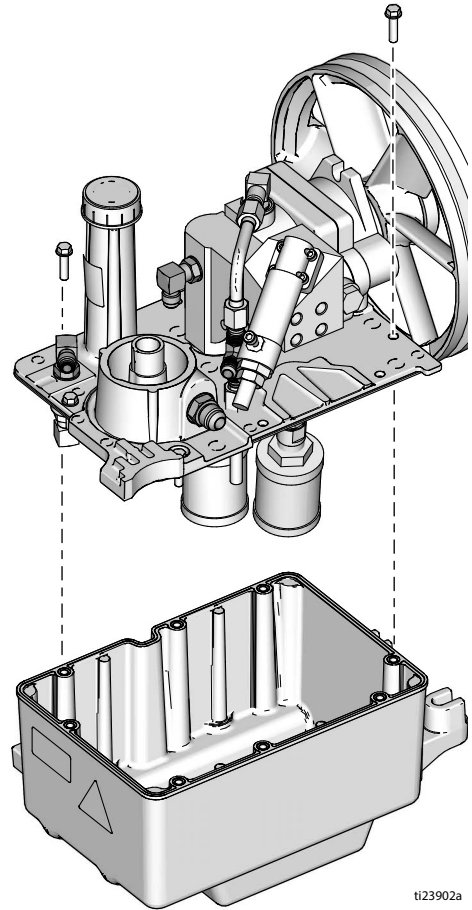

ti23902a

7. Remove pulley from pump. Remove four screws and pump from reservoir cover.

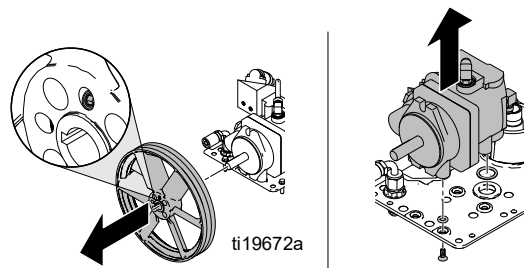

ti19672a

Installation

1. Install pump onto oil reservoir cover with four screws. Make sure the five o-rings are in place.

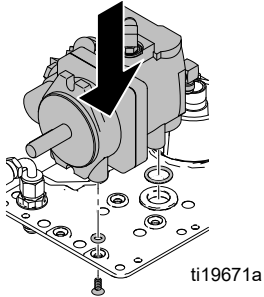

2. If hydraulic oil is contaminated in reservoir, drain reservoir and remove contamination. Install oil reservoir cover with eight screws to the oil reservoir base.

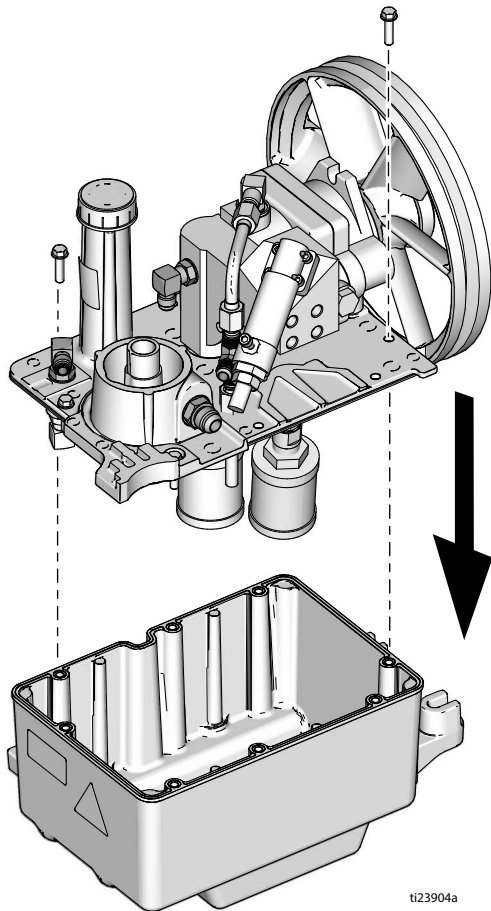

3. Install pulley on pump shaft and maintain belt alignment to inner groove of the clutch pulley. Tighten two pulley screws.

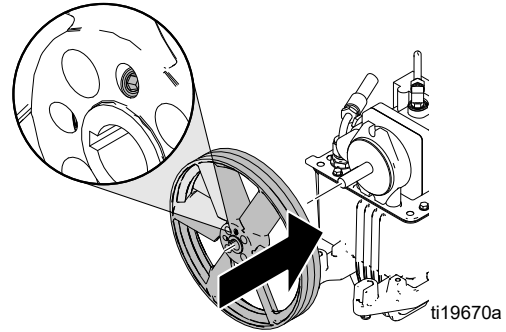

4. Turn pressure control knob clockwise until seated.



5. Turn hydraulic pump pressure control clockwise until seated then counterclockwise 1/6 turn.

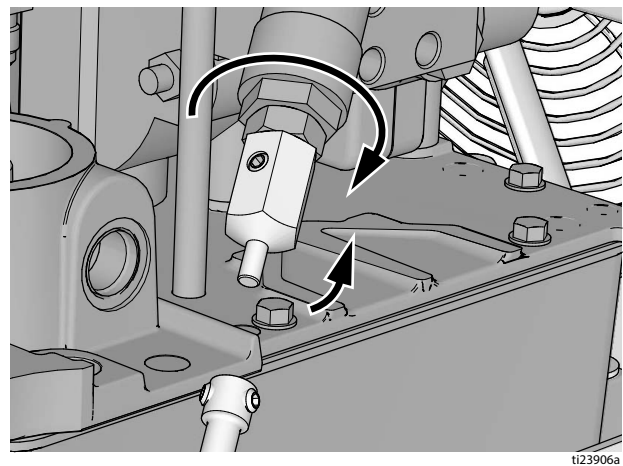

6. Install cable and tighten two set screws.

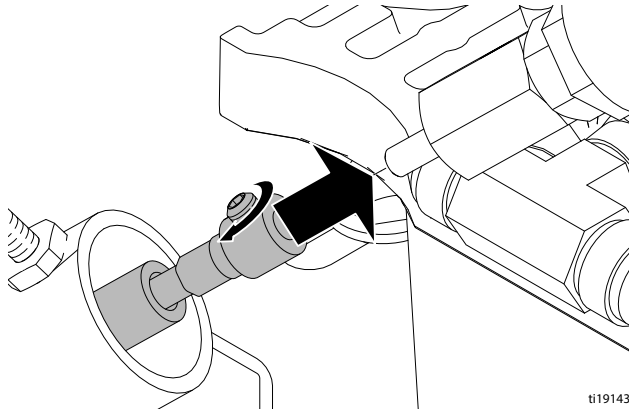

ti19143b

7. Slide cable sleeve up and tighten screw.

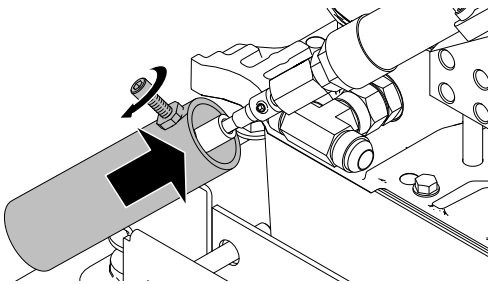

ti19145a

8. Connect five hydraulic hoses to fittings on oil reservoir. Replace oil filter.

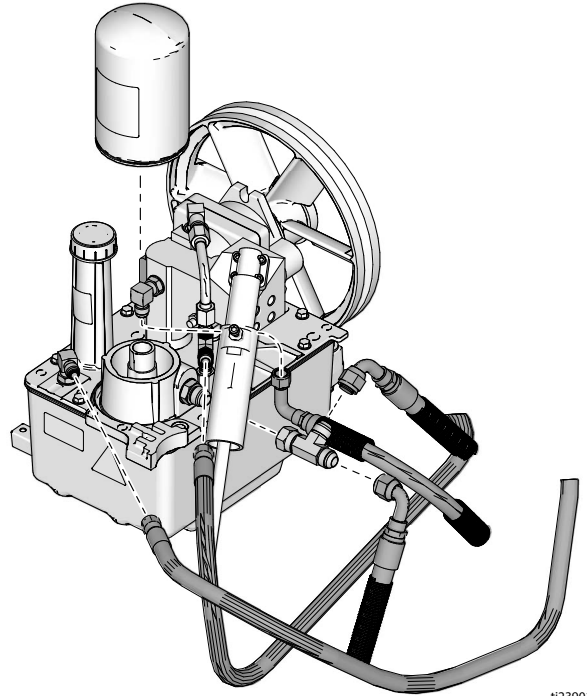

ti23901a

9. Install and tension belts, see **Oil Reservoir Belt Replacement**, page 11 and **Ground Drive Belt Replacement**, page 10.
10. Fill reservoir and purge hydraulic system, see **Hydraulic System Purging**, page 12.

Hydraulic Gun Manifold Replacement



Removal

1. Remove tank lid(s) and siphon tube(s).

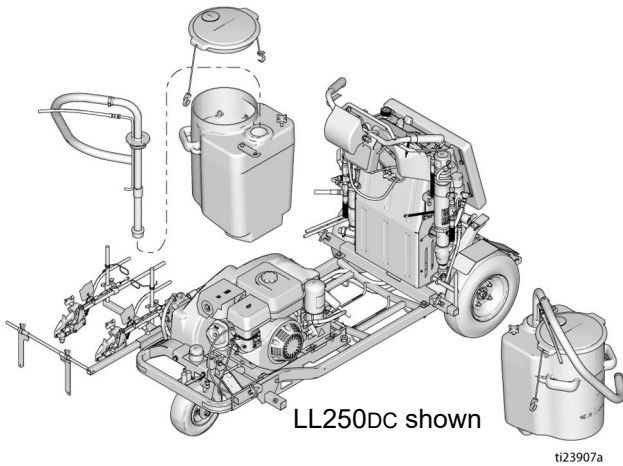

2. Remove tank(s) from unit.
3. Remove six screws and then remove front shield from unit.

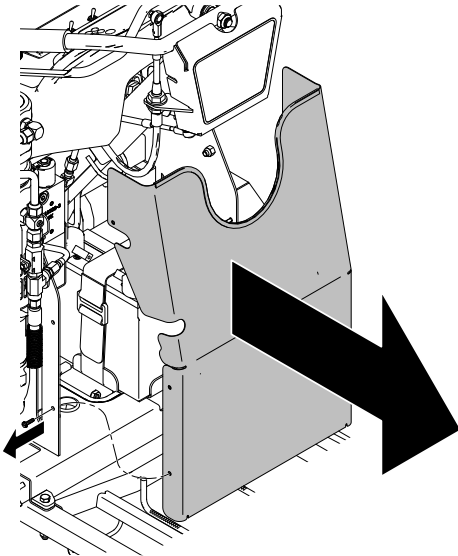

4. Remove four screws and pad.

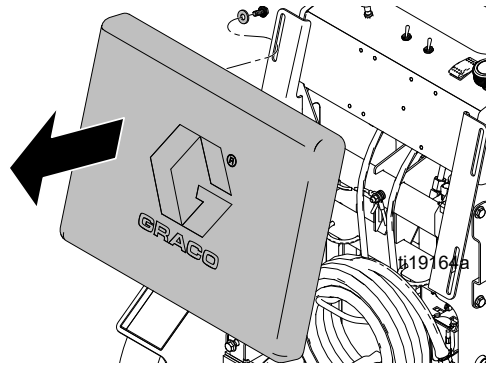

5. Label wire harnesses **GUN 1**, **GUN 2**, and **GUN 3**. Disconnect three wire harnesses from solenoids.

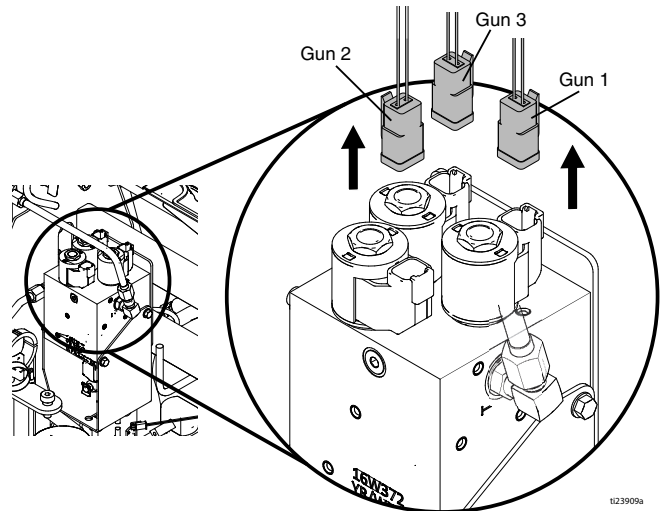

6. Label gun cables **GUN 1**, **GUN 2**, and **GUN 3**. Disconnect gun cables from actuators.

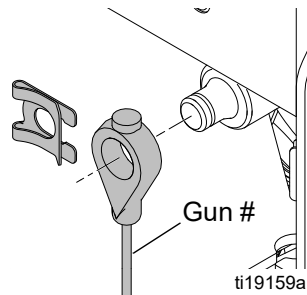

7. Use a needle-nose pliers to remove gun cables from bracket.

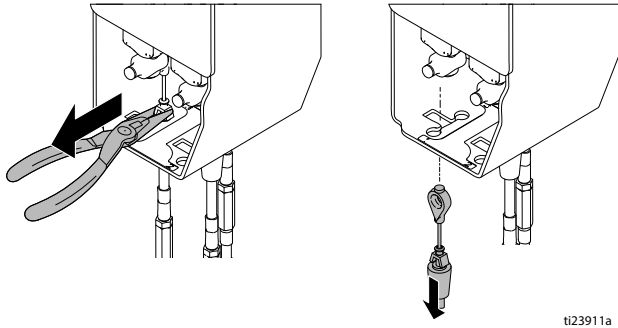

8. Use wrench to disconnect manifold tubes by the paint pump. **NOTE:** Oil will spill. Use a rag to contain the oil.

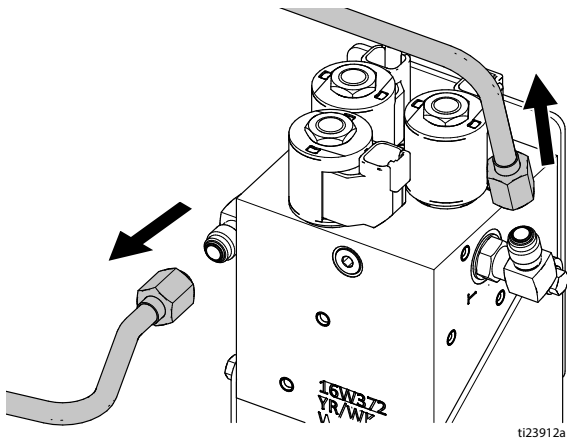

9. Disconnect manifold tubes at manifold.
10. Remove two mounting bolts and slide hydraulic manifold down and out from unit.

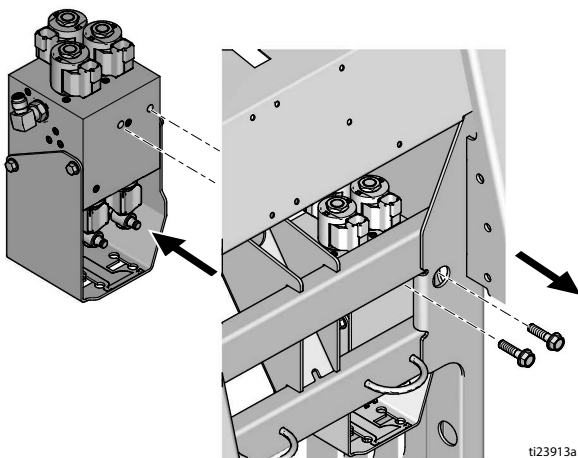

Installation

1. Slide hydraulic manifold in and up into unit. Install and tighten two mounting bolts.

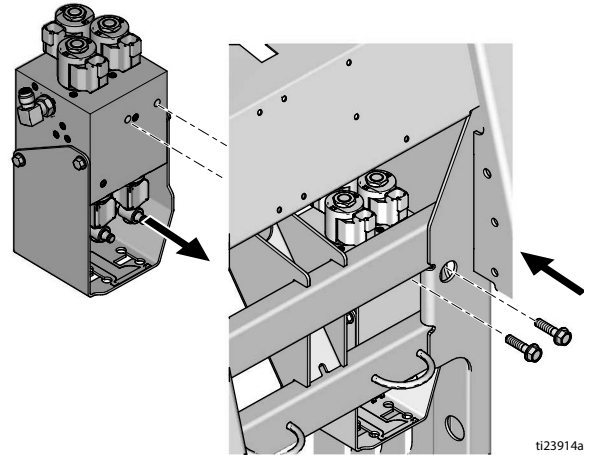

2. Loosely install manifold tubes to manifold.
3. Loosely install manifold tubes by the paint pump. Tighten four nuts.

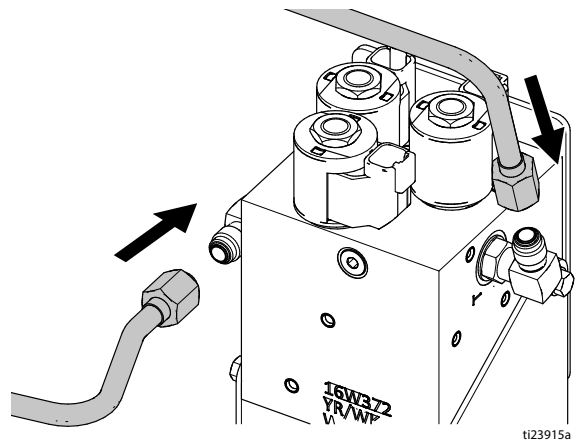

Hydraulic Gun Manifold Replacement

4. Observe label on bracket. Push labeled gun cables into manifold brackets.

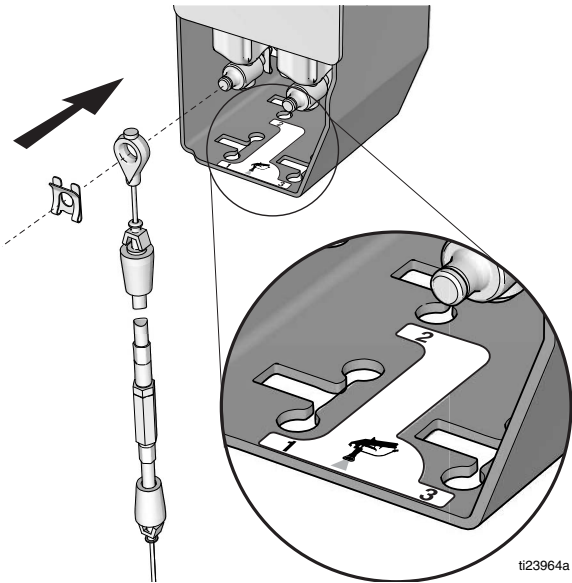

5. Connect gun cables to actuators.

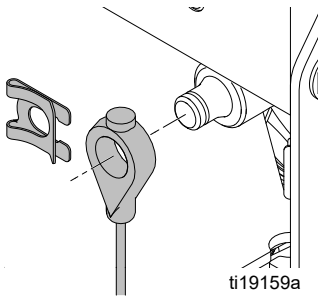

6. Connect three wire harnesses to solenoids.

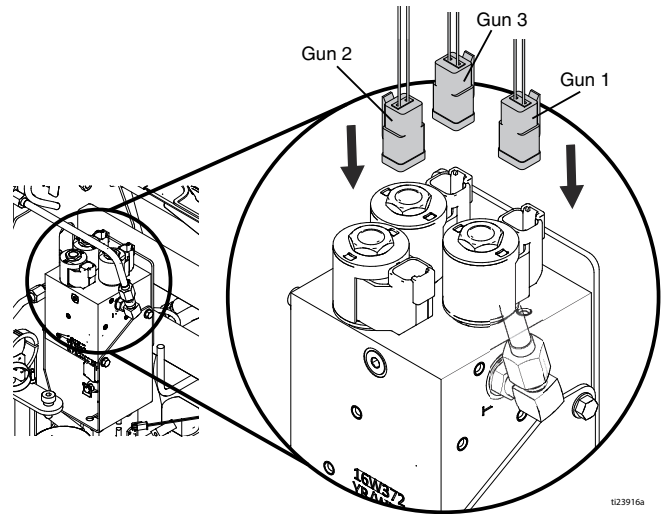

7. Install pad and tighten four screws.
8. Install front shield to unit and tighten six screws.
9. Install tank(s), lid(s) and insert siphon tube(s) into tank(s).

NOTE: The hydraulic gun manifold is self-purging.

Paint Pump Replacement

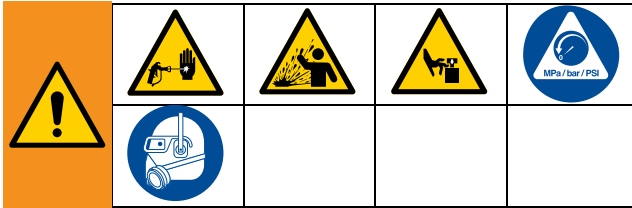

This equipment stays pressurized until pressure is manually relieved. To help prevent serious injury from pressurized fluid, such as skin injection, splashing fluid and moving parts, follow the Pressure Relief Procedure when you stop dispensing and before cleaning, checking, or servicing the equipment.

Removal

1. Perform **Pressure Relief Procedure**, page 9.
2. Disconnect suction tube (120).
3. Disconnect hose (123) and fitting (95) from paint pump (107). Note orientation of fitting (95) for installation.
4. Remove screw (115), nut (116) and pump guard (114).
5. Use hammer to loosen pump jam nut (106).
6. Slide down retainer (104) and remove pin (105).
7. Unscrew and remove paint pump (107).

Installation

1. Extend pump rod out of pump (107).
2. Insert pump rod into hydraulic motor rod and install pin (105) and retainer (104).
3. Thread pump (107) into hydraulic motor housing until pump bottoms out. Unscrew pump one full turn and orient pump outlet as noted in **Removal** step 3.
4. Use hammer to tighten pump jam nut (106).
5. Install guard (114) with screw (115) and nut (116).
6. Install fitting (95) and connect hose (123).
7. Connect suction tube (120).

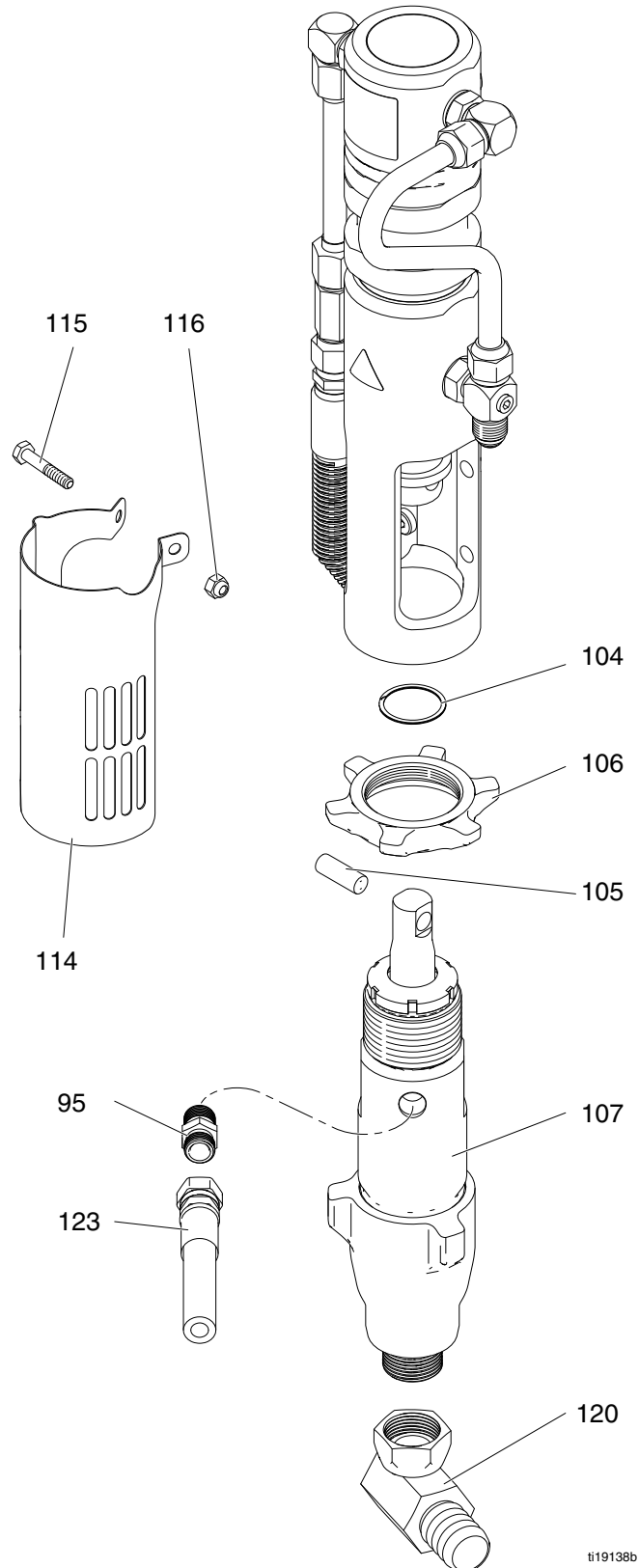

ti19138b

Hydraulic Motor Replacement

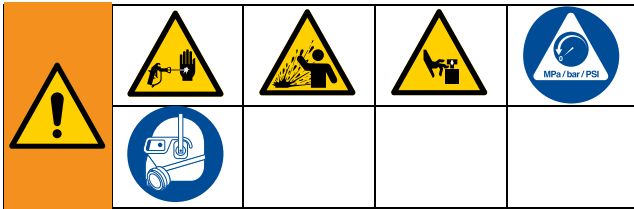

This equipment stays pressurized until pressure is manually relieved. To help prevent serious injury from pressurized fluid, such as skin injection, splashing fluid and moving parts, follow the Pressure Relief Procedure when you stop dispensing and before cleaning, checking, or servicing the equipment.

Removal

1. Perform **Pressure Relief Procedure**, page 9.
2. Remove paint pump, see **Paint Pump Replacement**, page 21.
3. Disconnect fitting (108) above ball valve (109).
NOTE: Oil will spill out of hoses. Have rags and waste pail nearby.
4. Disconnect hose (74) for pump 1 or tube (98) for pump 2.
5. Disconnect pump counter (112) with 2 screws (113).

NOTICE

Use a screwdriver to lift pump piston up to gain access to mounting bolts and avoid contact with piston. Contact with pump mounting bolts can scratch and damage the pump piston.

6. Remove four mounting bolts (116) from hydraulic motor and remove motor from sprayer.

Installation

1. Install hydraulic motor with four mounting bolts (116).

NOTICE

Use a screwdriver to lift pump piston up to gain access to mounting bolts and avoid contact with piston. Contact with pump mounting bolts can scratch and damage the pump piston.

2. Install pump counter (112) with two screws (113).
3. Connect hose (74) or tube (98) to fitting.
4. Connect fitting (108) above ball valve (109).
5. Install paint pump, see **Paint Pump Replacement**, page 21.
6. Purge hydraulic system, see **Hydraulic System Purging**, page 12.

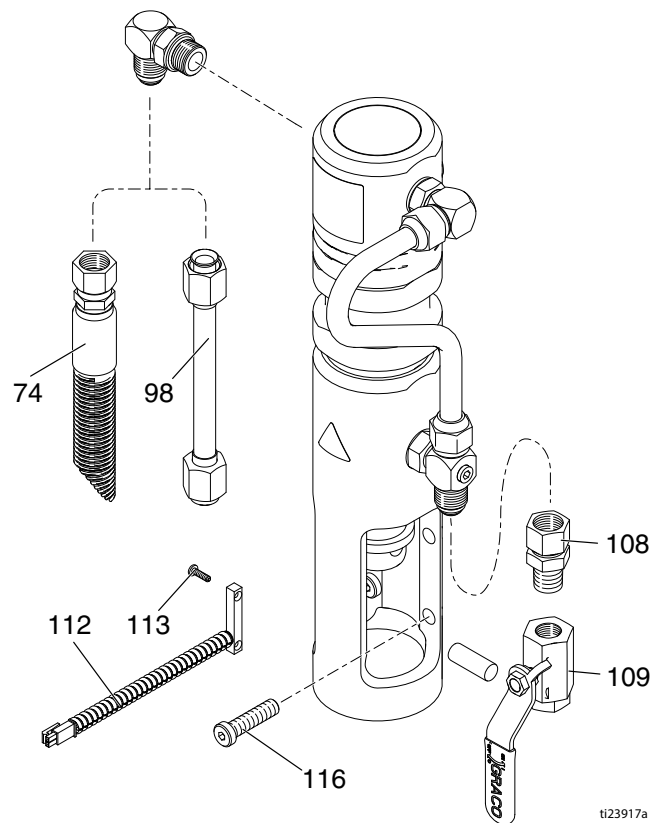

ti23917a

Clutch Replacement



Removal

1. Remove ground drive belt, page **Ground Drive Belt Replacement**, page 10.
2. Remove oil reservoir belt, see **Oil Reservoir Belt Replacement**, page 11.
3. Remove two hold-down bolts for the ground drive pump bracket.

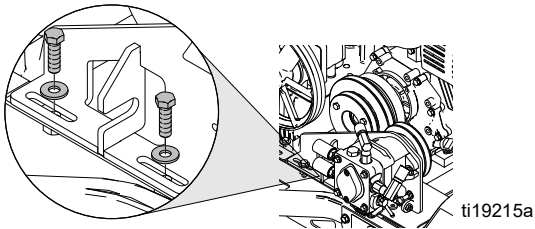

4. Unscrew tensioning bolt from the ground drive pump bracket.

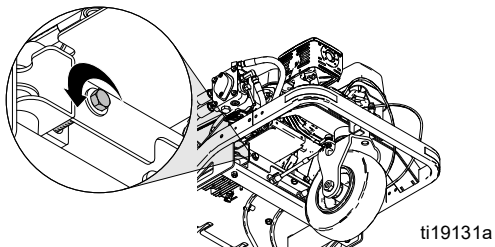

5. Move ground drive pump assembly aside.

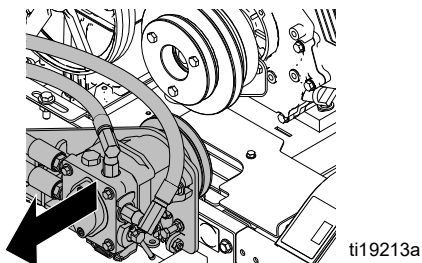

6. Remove three bolts (81) and pulley (61).

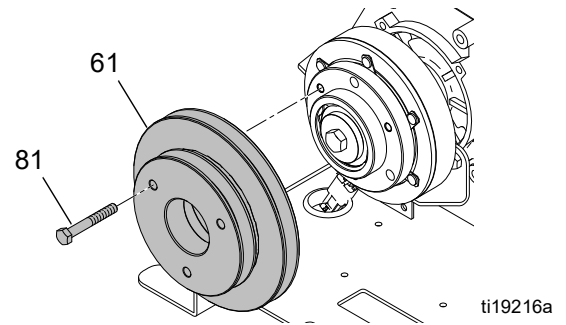

7. Remove engine recoil starter and place a screwdriver through the recoil starter cup.

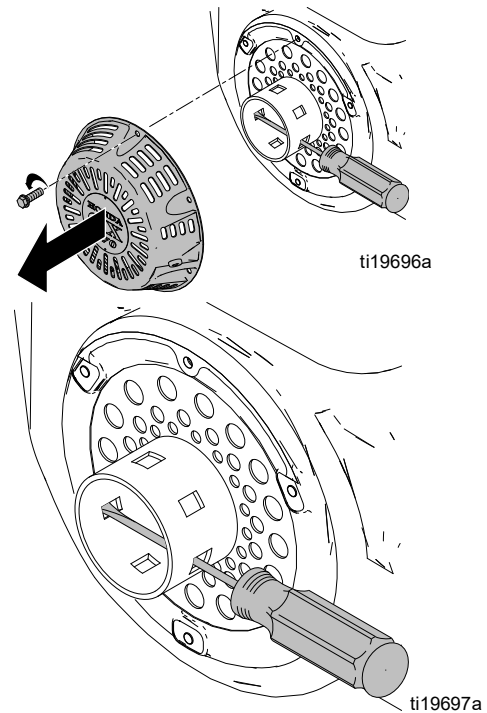

8. Remove center bolt (59) and remove clutch (57).

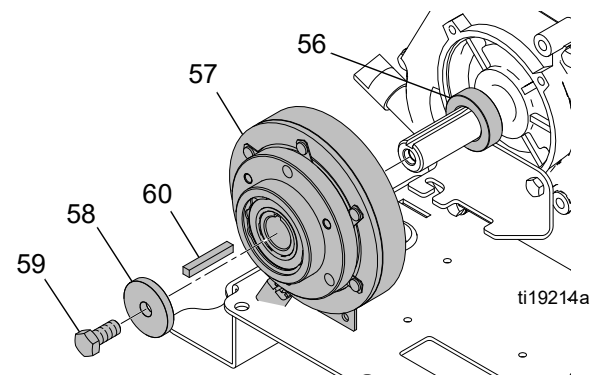

9. Disconnect clutch connector to main wire harness.

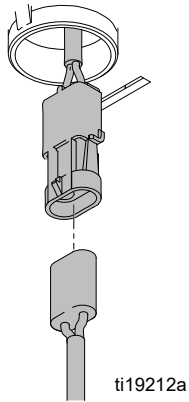

3. Install heavy washer (58) and bolt (59) onto crankshaft. Torque bolt to 45 +/- 5 ft-lb (61 +/- 7 N•m). Use screwdriver in recoil starter cup to hold crankshaft.

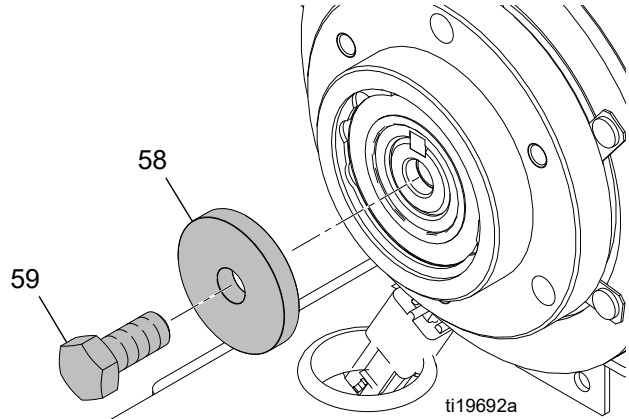

Installation

1. Install spacer (56) and key (60) onto crankshaft. Slide clutch (57) onto crankshaft.

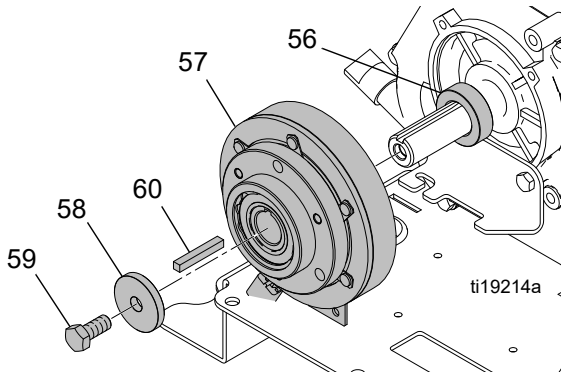

4. Install pulley (61) and torque three screws (81) to 10 ft-lb (13 N•m).

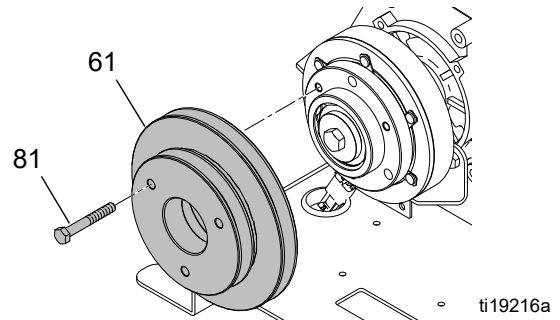

2. Align clutch and wire in bracket.

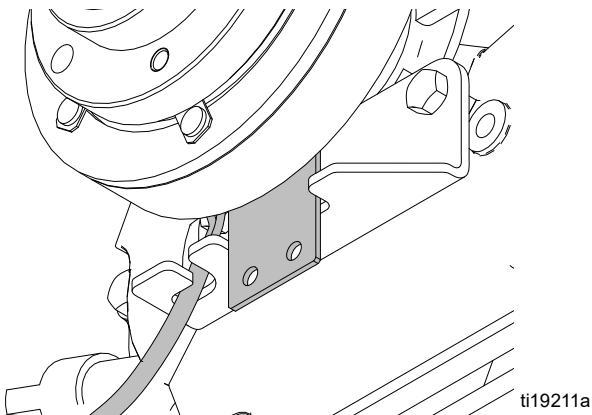

5. Install recoil starter onto engine.

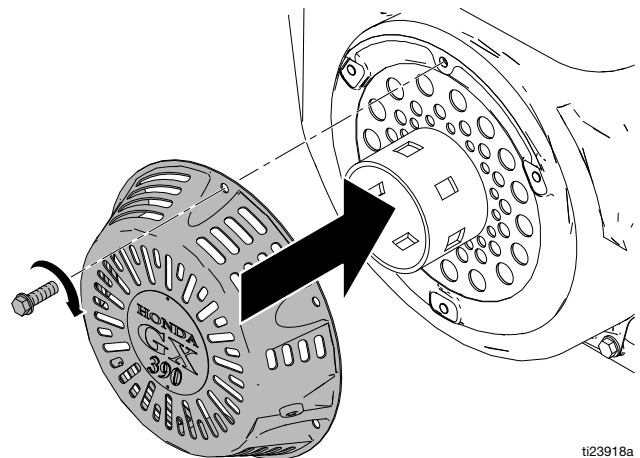

6. Connect clutch to wire harness.

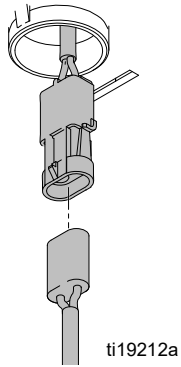

7. Install ground drive pump assembly with tensioning and two hold-down bolts.

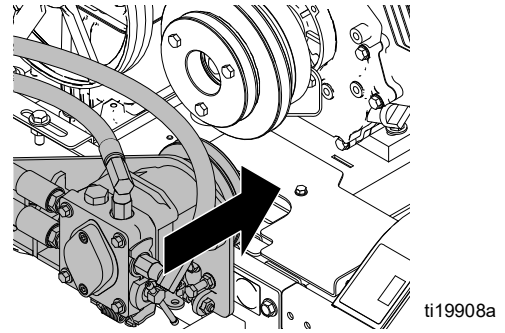

8. Install and tension belts, see **Oil Reservoir Belt Replacement**, page 11 and **Ground Drive Belt Replacement**, page 10.

Engine Replacement



Removal (Honda)

1. Remove clutch, see **Clutch Replacement**, page 23.

NOTICE

To reduce the risk of battery damage and shorts, always disconnect **NEGATIVE** (black wire) first.

2. Disconnect two negative (black) battery wires at battery. Negative battery post is located above platform on the left side.
3. Disconnect seven wires from engine.

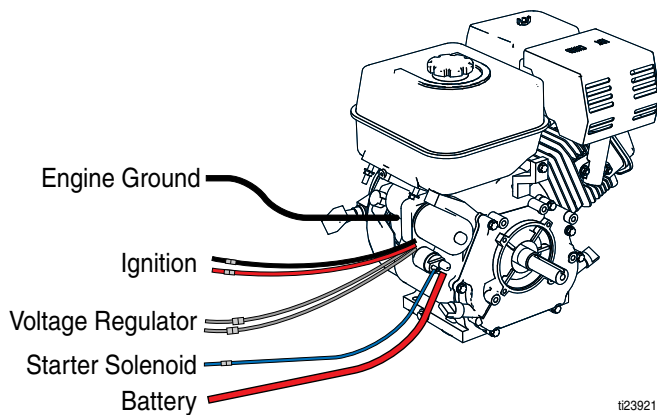

4. Remove air filter cover, element and base.

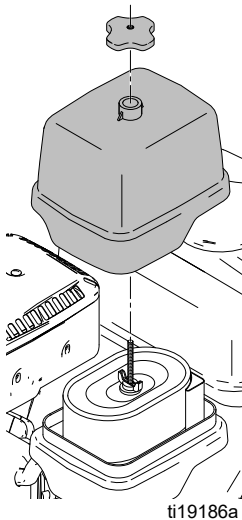

5. Disconnect throttle cable.

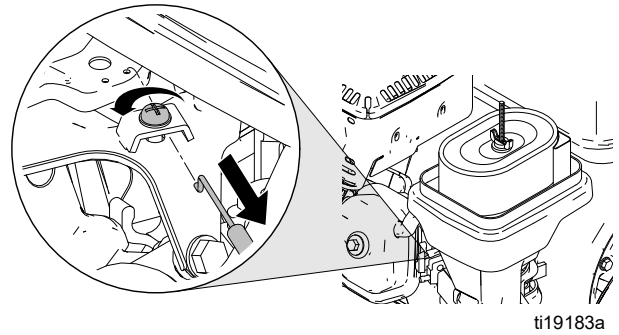

6. Disconnect choke cable.

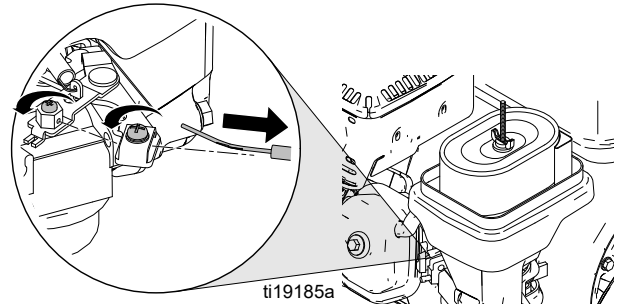

7. Remove four mounting bolts from engine.

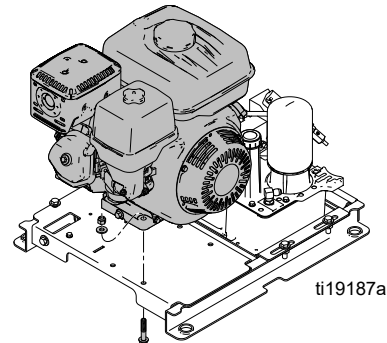

8. Remove engine. **NOTE:** Engine voltage regulator is located below engine mounting plate. Remove two screws and disconnect wires.

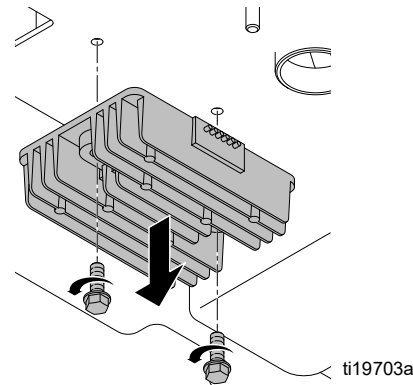

Installation (Honda)

1. Install engine voltage regulator below engine mounting plate with two screws. Connect regulator to wire harness.

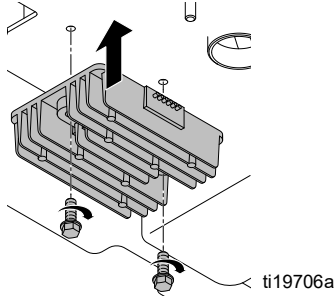

2. Install engine and tighten four mounting bolts and nuts.

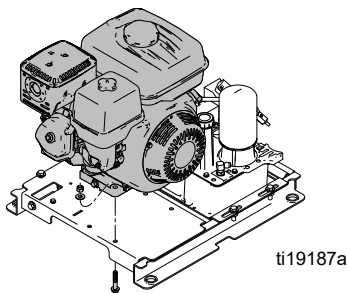

3. Install choke cable:
 - a. Make sure choke knob is pressed down.
 - b. Insert choke cable wire into hex-shaped pivot.
 - c. Insert cable sheathing under cable clamp and tighten screw.
 - d. Tighten screw on hex-shaped pivot.
 - e. Verify proper operation of engine choke.

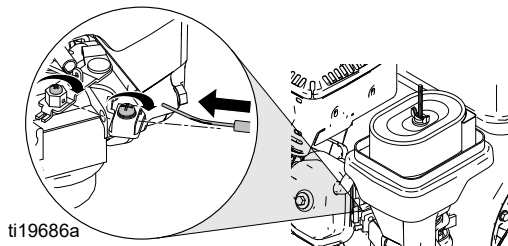

4. Install throttle cable.
 - a. Place speed lever to high speed.
 - b. Insert "Z" bend wire into hole furthest from pivot.
 - c. Place cable sheathing under clamp and pull cable against high speed stop screw.
 - d. Tighten screw on cable clamp.
 - e. Verify proper operation of speed lever.

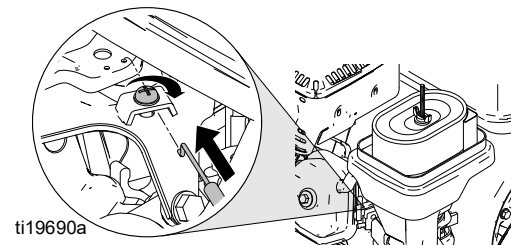

5. Install air filter base, element and cover.

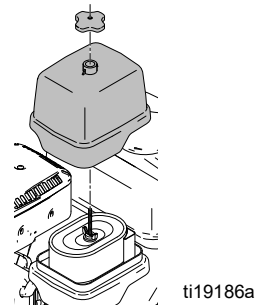

6. Connect seven wires to engine.

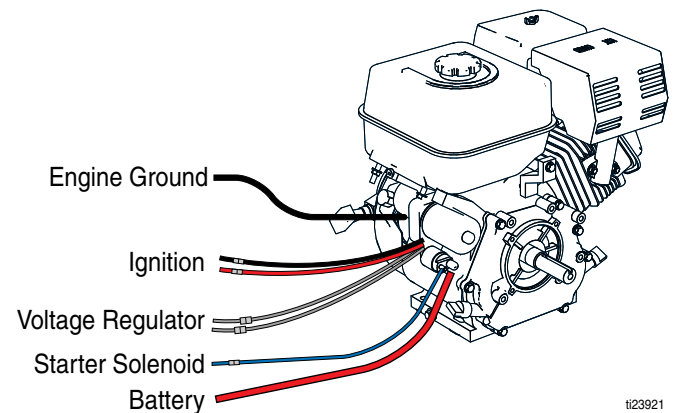

7. Install clutch, see **Clutch Replacement**, page 23.
8. Connect two negative (black) wires at battery.
9. Add gas and oil to engine (see Operation manual).
10. Start engine and verify high speed of 3600 rpm.

Removal (Vanguard)

1. Remove clutch, see **Clutch Replacement**, page 23.

NOTICE

To reduce the risk of battery damage and shorts, always disconnect NEGATIVE (black wire) first.

2. Disconnect two negative (black) battery wires at battery. Negative battery post is located above platform on the left side.
3. Disconnect eight wires from engine. Remove relay (486) and relay mounting bracket (485).

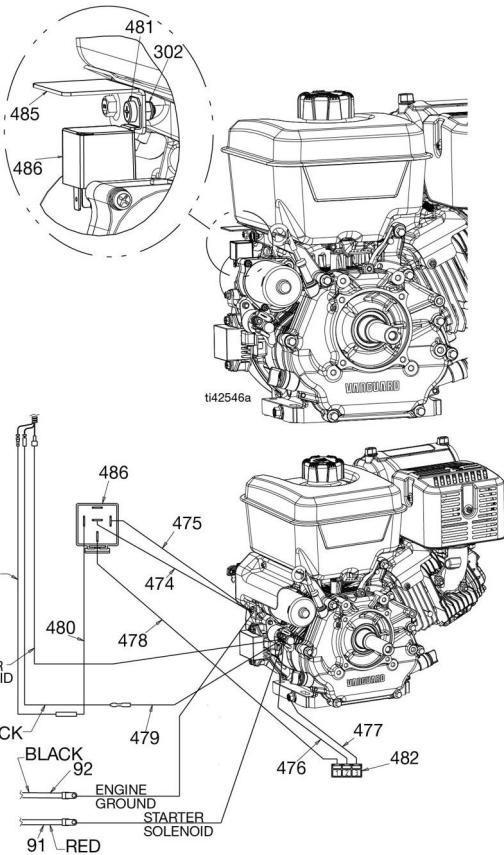

4. Disconnect throttle cable (A).

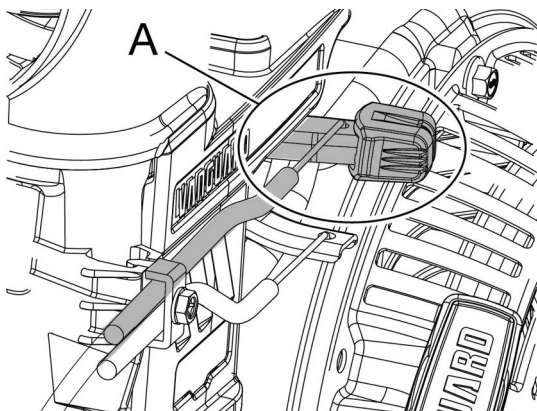

5. Disconnect choke cable (B).

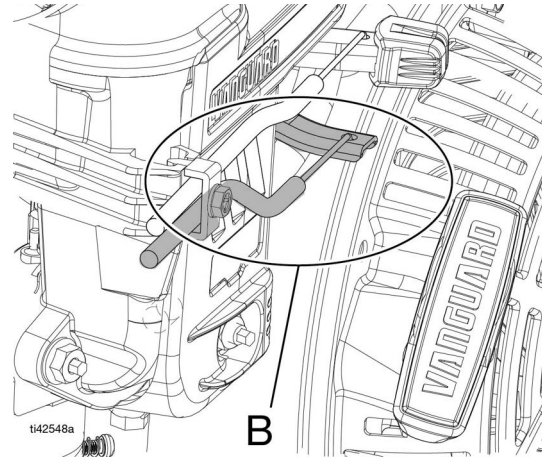

6. Remove four mounting bolts from engine.

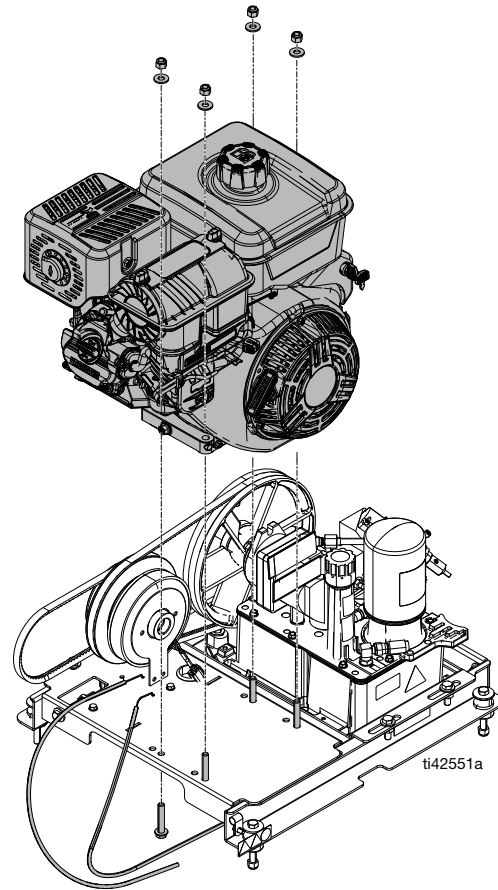

7. Remove engine.

Installation (Vanguard)

1. Install engine and tighten four mounting bolts and nuts.

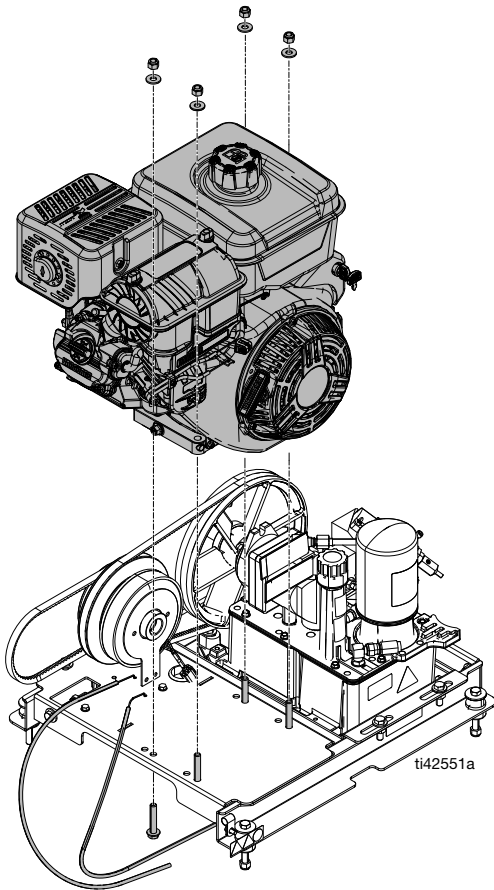

2. Install choke cable:
 - a. Remove and discard throttle and choke lever end caps.
 - b. Insert Z-bend of throttle cable (A) into throttle lever.
 - c. Insert Z-bend of choke cable (B) into choke lever.
 - d. Remove and discard single clasp (C) and screw (F) shown below.
 - e. Remove double clasp (C) and screw (F), relocate to secure throttle (top position) and choke (bottom position) cables as shown.
 - f. Assure throttle and choke levers (E) both on the engine and control panel are set to the low and open position, respectively.

- g. Tighten screw (F) on double clasp (C) to set position of throttle (A) and choke (B) cables.

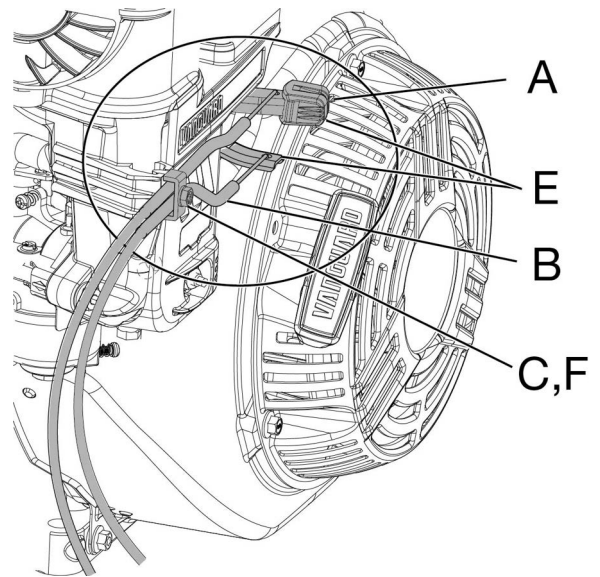

3. Connect eight wires to engine. Install relay mounting bracket (485) and relay (486).

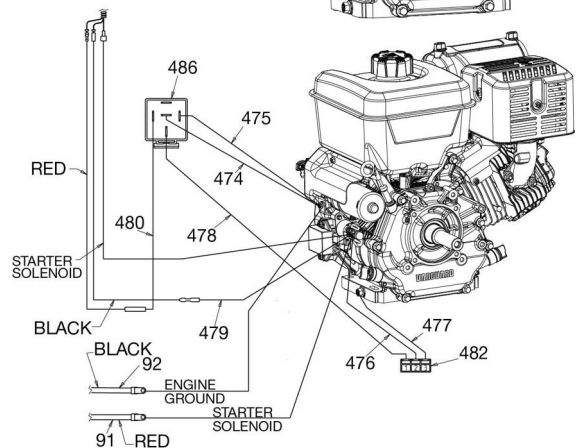
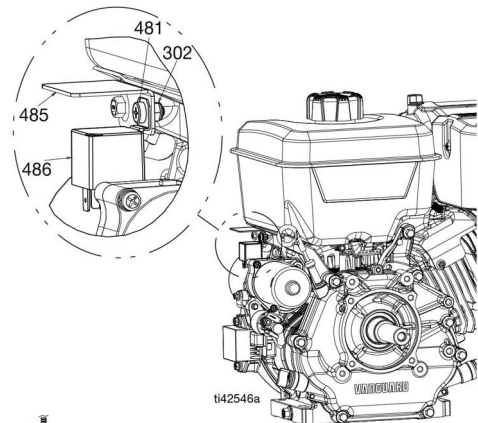

4. Install clutch, see **Clutch Replacement**, page 23.
5. Connect two negative (black) wires at battery.
6. Add gas and oil to engine (see Operation manual).
7. Start engine and verify high speed of 3600 rpm.

Touch-Pad Display

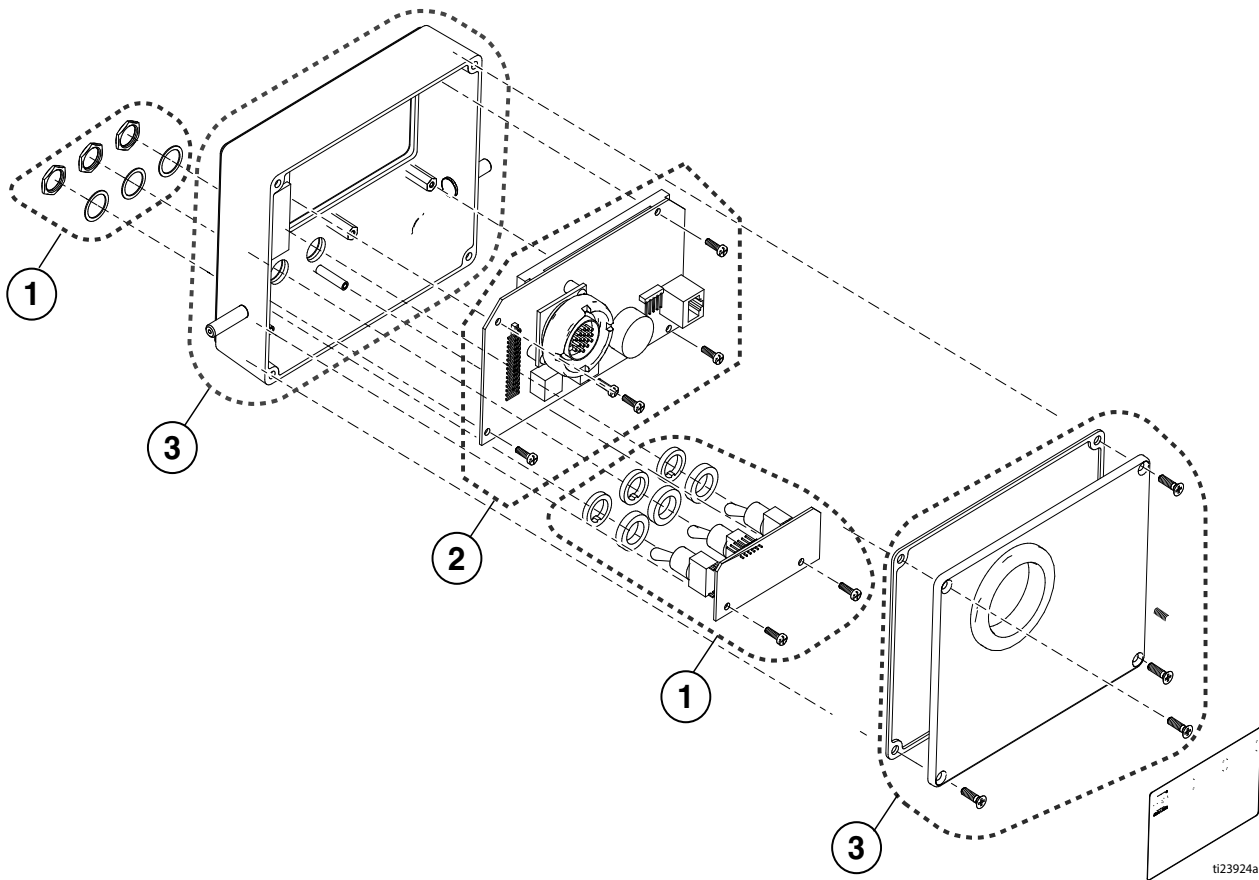

NOTICE

To avoid electrostatic-discharge (ESD) always use wrist strap 112190 when servicing the touch-pad display.

1. Toggle switch kit.
 - a. Torque screws to 3-5 in-lb (0.34-0.56 N•m)
 - b. Torque nuts to 3-5 in-lb (0.34-0.56 N•m)
2. Display kit. Remove protective film from display face.
 - a. Torque screws to 3-5 in-lb (0.34-0.56 N•m)
3. Membrane switch kit.
 - a. Torque screws to 1-2 in-lb (0.11-0.23 N•m)

Control Board Replacement

Removal

1. To disconnect power remove fuse, see **Fuse Replacement**, page 35.
2. Remove siphon tube(s) and lid(s).

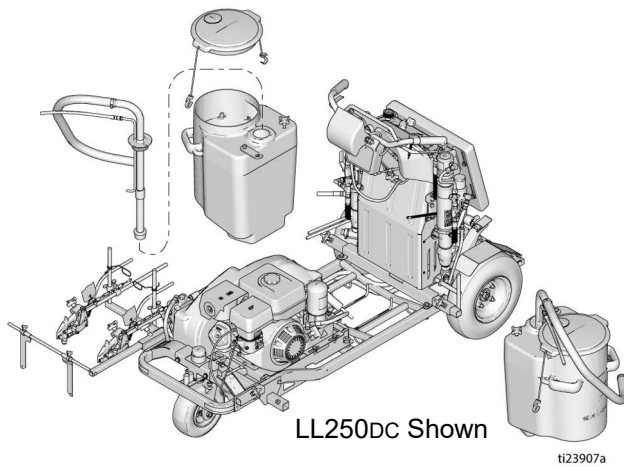

3. Remove tank(s) from unit.
4. Remove six screws and then remove front shield from unit.

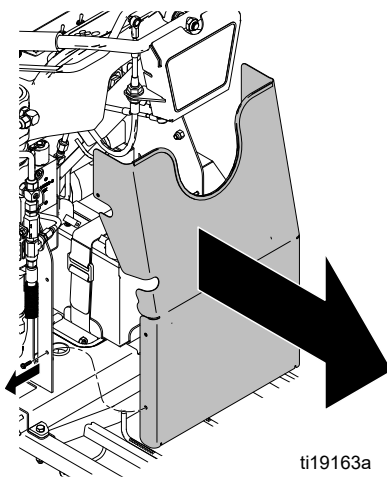

5. Remove four screws and remove pad.

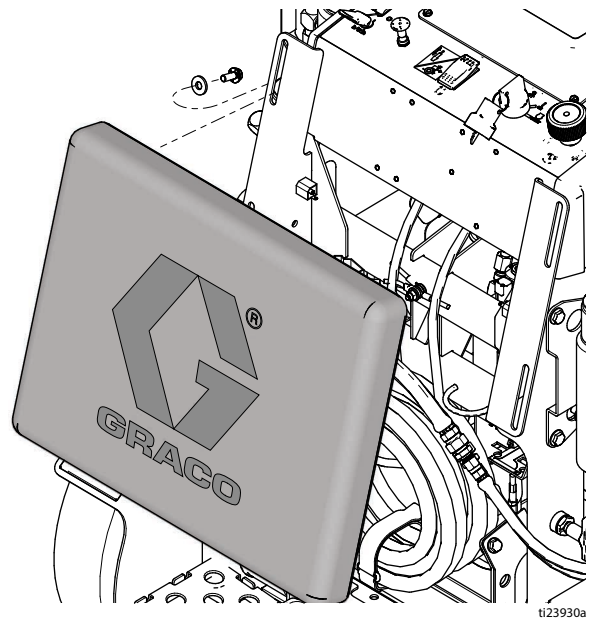

6. Remove six screws and control shroud.

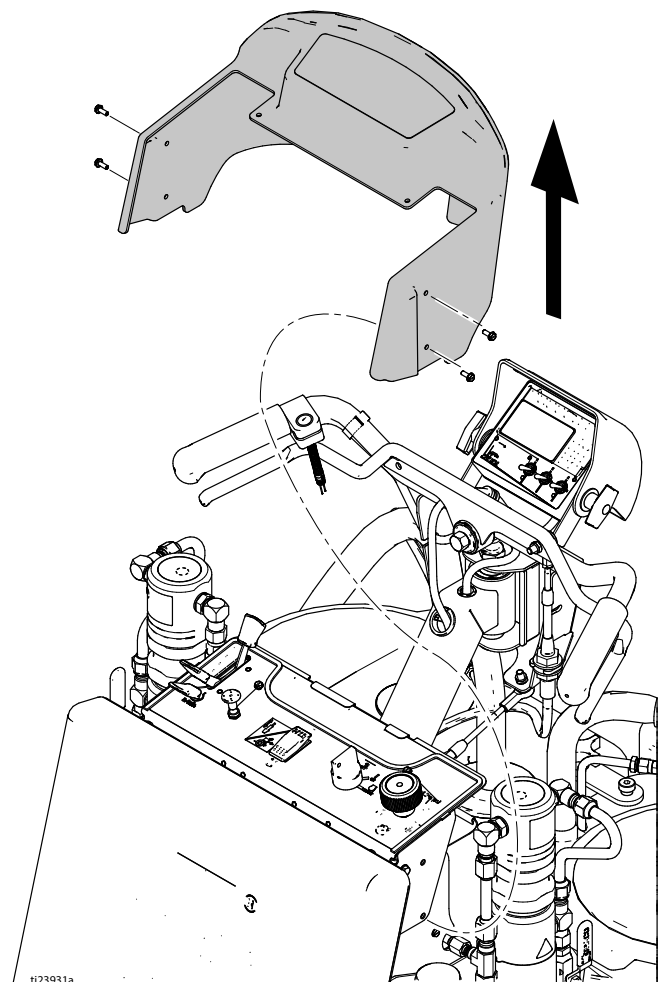

Control Board Replacement

7. Remove two screws and splash shield.

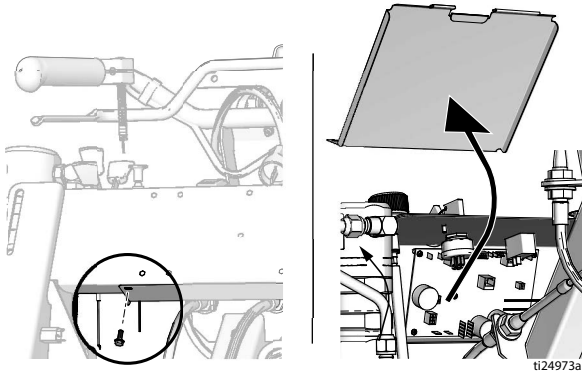

8. Disconnect all wires from control board.
9. Remove eight control board mounting screws and then remove control board.

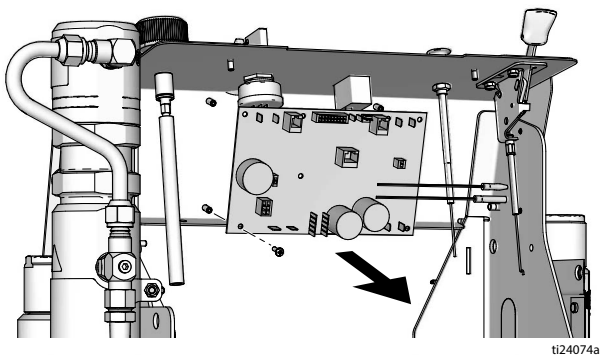

Installation

1. Install control board with eight mounting screws.

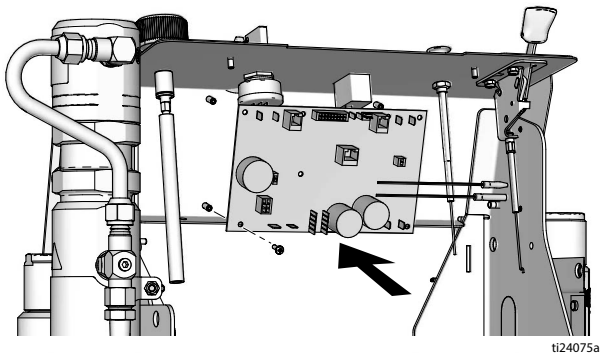

2. Before connecting wires to control board, make sure that all wires are routed above the two steering cables.

3. Connect all wires to control board. See, **Notes**, page 51. Pump number 1 is on the left when you stand in the operator position.
4. Bundle and secure wires with a cable tie just inboard of the choke cable.
5. Bundle and secure wires with a cable tie just outboard of the key switch.
6. Install fuse, see **Fuse Replacement**, page 35. Check control, switches and display.
7. Install splash shield with two screws.

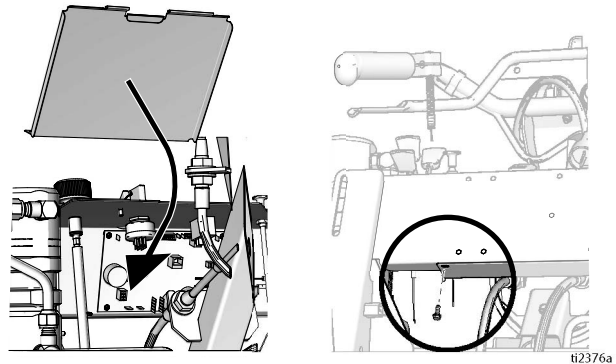

8. Install control shroud with six screws. See **Removal** step 6.
9. Install pad and tighten four screws.

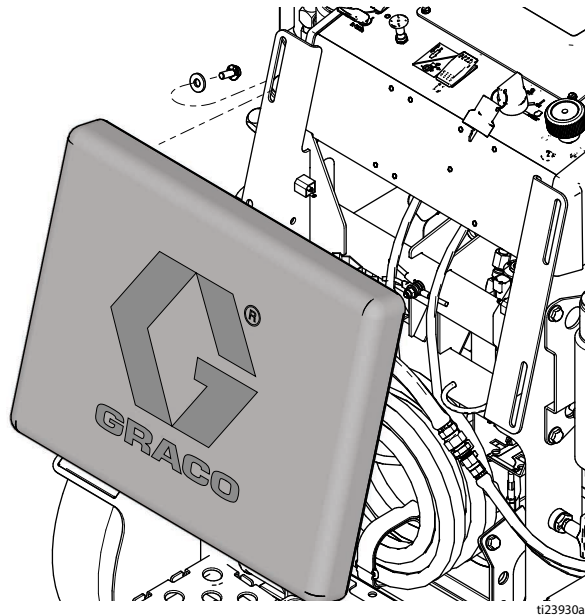

10. Install front shield and tighten six screws.

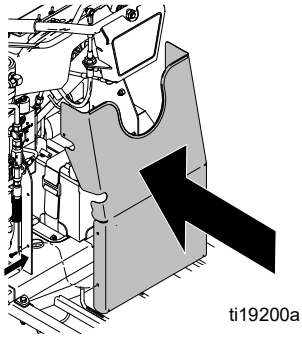

11. Install tank(s), lid(s) and siphon tube(s).

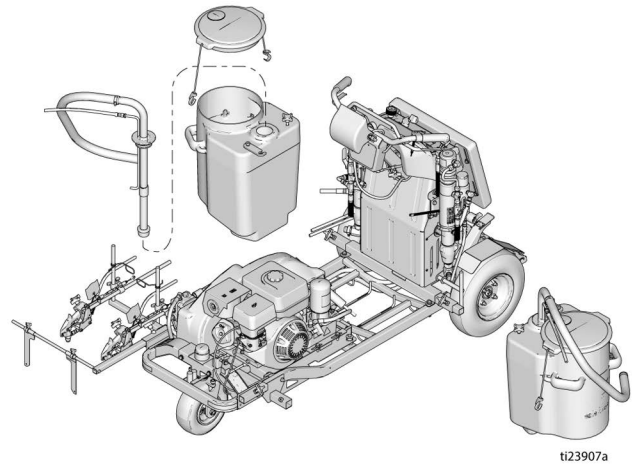

12. If control board was replaced select language, units, and calibrate distance sensor (see Operation manual).

Battery Replacement



Removal

1. Battery may be removed from the back of the unit by sliding it out above the operator platform.
2. Loosen straps and move coiled hoses above the operators platform.
3. Loosen hold down strap from battery.

NOTICE

To reduce the risk of battery damage and shorts, always disconnect NEGATIVE (black wire) first.

4. Disconnect two black wires from battery.

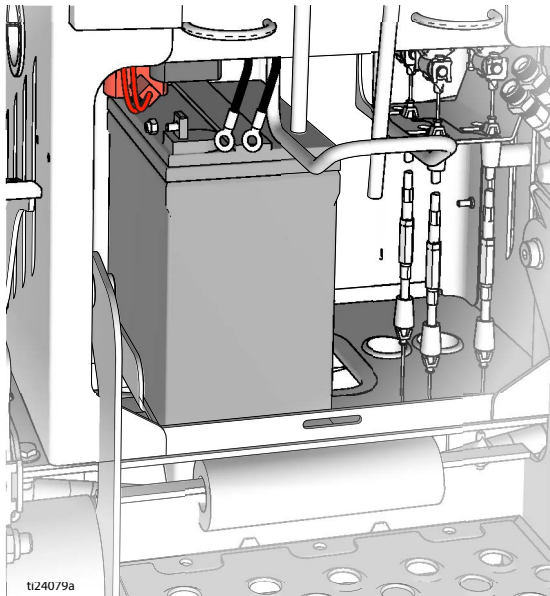

5. Lift battery and slide it back onto the platform. Disconnect two red wires from battery.

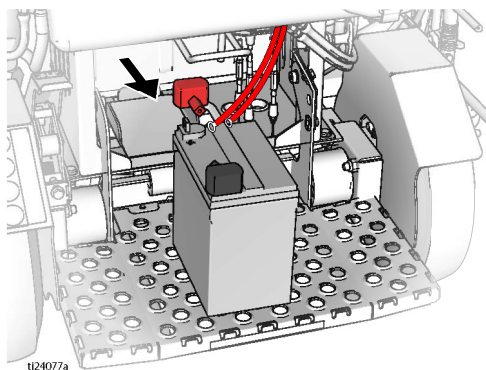

6. Remove battery.

Installation

NOTICE

To reduce the risk of battery damage and shorts, always connect NEGATIVE (black wire) last.

1. Place battery on operator platform. Connect two red wires to positive (+) post of the battery.

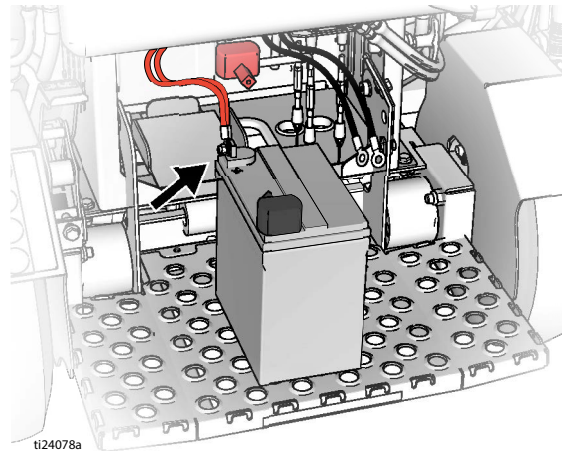

2. Pickup and slide battery into mounting position. Install battery hold down strap.
3. Connect two black wires to negative (-) post of the battery.

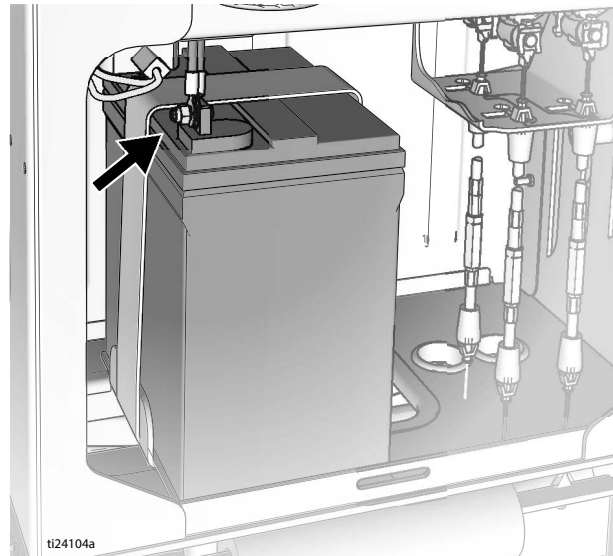

4. Place coiled paint hoses over bracket and secure with straps.

Fuse Replacement

1. Remove fuse cover.
2. Use needle-nose pliers to remove old fuse and inspect it for an open circuit.
3. If fuse is open, a wire has shorted to the frame or auxiliary lighting requires too much power. Check wiring or reduce auxiliary lighting before replacing fuse.
4. Use needle-nose pliers to install new fuse.
5. Replace cover.

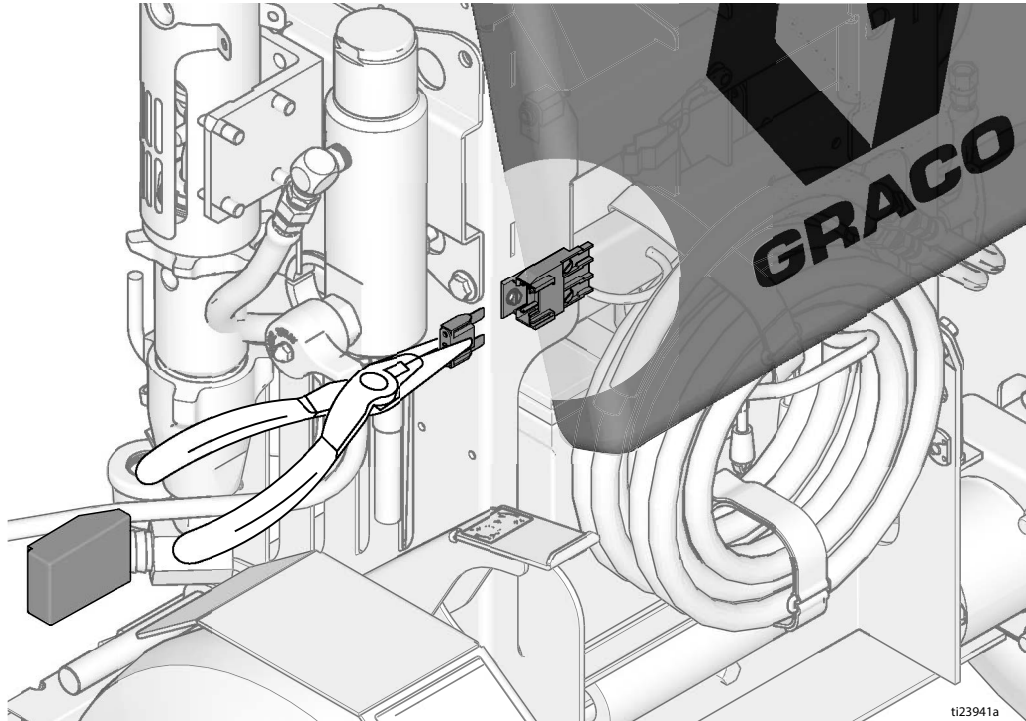

Forward/Reverse Cable Replacement



Removal

1. If equipped with a Pressurized Bead System, remove pressurized bead tanks and compressor. See Pressurized Bead System manual 332230.
2. Remove tank lids and siphon tubes.

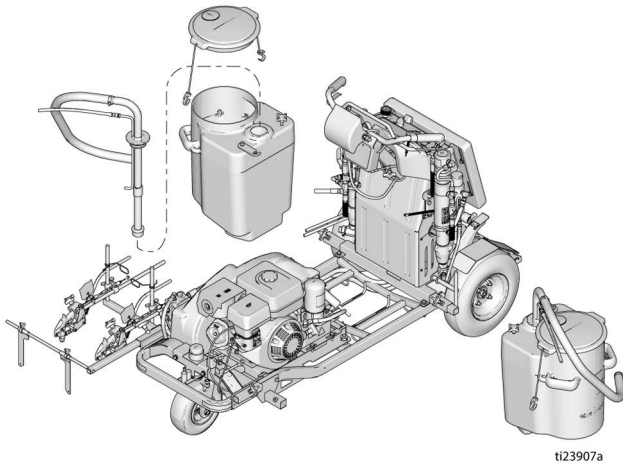

ti23907a

3. Remove tanks from unit.
4. Remove six screws and front shield from unit.

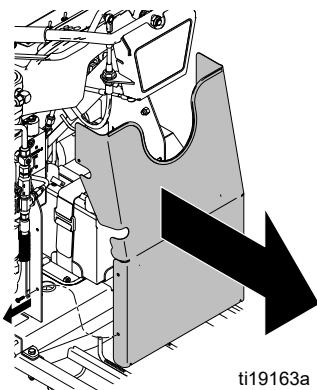

ti19163a

5. Loosen four screws and remove belt cover.

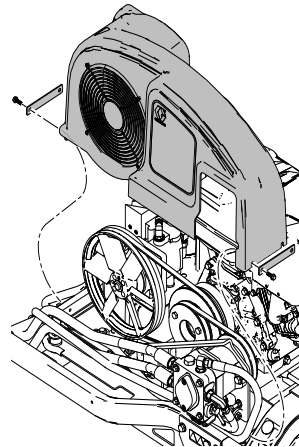

ti19128a

6. At the handlebar, remove locknut (3) and ball joint (40) from handlebar forward/reverse lever. Remove ball joint (40) from cable (148) and save if not replacing. Loosen two nuts on cable (148) and remove from bracket.

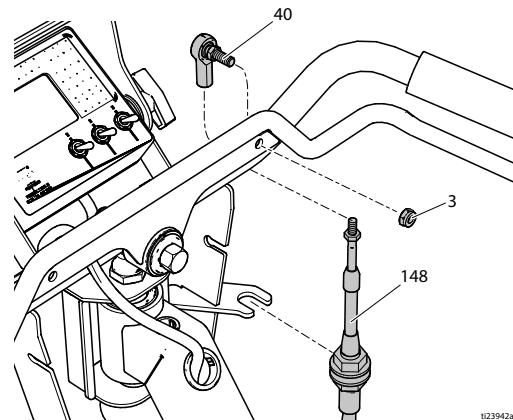

ti23942a

7. At the ground drive pump, remove locknut (3) and ball joint (40) from ground drive pump. Remove ball joint from cable and save if not replacing. Loosen two nuts on cable (148) and remove from bracket (62).

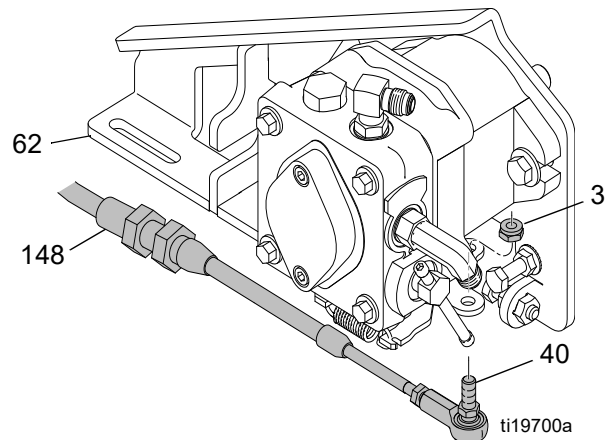

ti19700a

8. Install new cable (148) as old cable is removed to follow same route through frame.

Installation

1. Install new cable (148) by following same route as old cable is being removed.
2. At ground drive pump bracket (62), install cable (148) in bracket slot and tighten two nuts. Install ball joint (40) onto cable and attach ball joint (40) to ground drive pump with locknut (3).

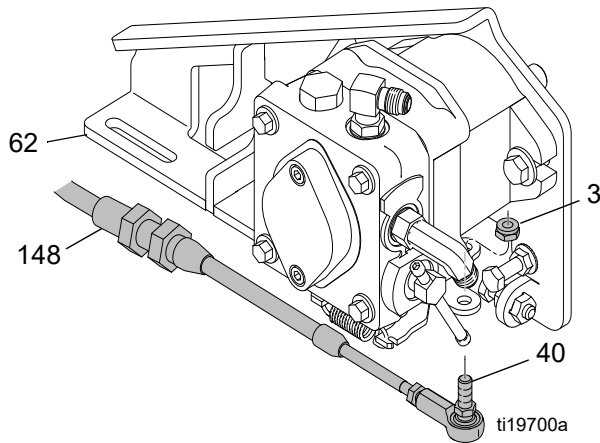

3. Install cable (148) into handlebar bracket and tighten two nuts. Install ball joint (40) onto cable. Install ball joint into handlebar forward/reverse lever and tighten locknut (3).

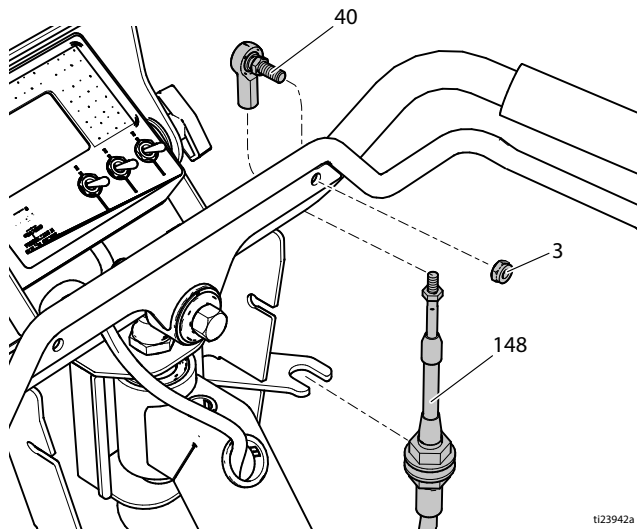

4. Verify that the handlebar forward/reverse lever does not touch handlebar grips. Adjust cable and ball joints if needed.
5. Install belt cover and tighten four screws.
6. Install front shield onto unit and tighten the six screws.
7. Install tanks onto unit.
8. Install siphon tubes and tank lids.
9. If equipped with a Pressurized Bead System, install pressurized bead tanks and compressor. See Pressurized Bead System manual 332230.

Steering Cable Replacement



Removal

1. Loosen four screws and remove pad.

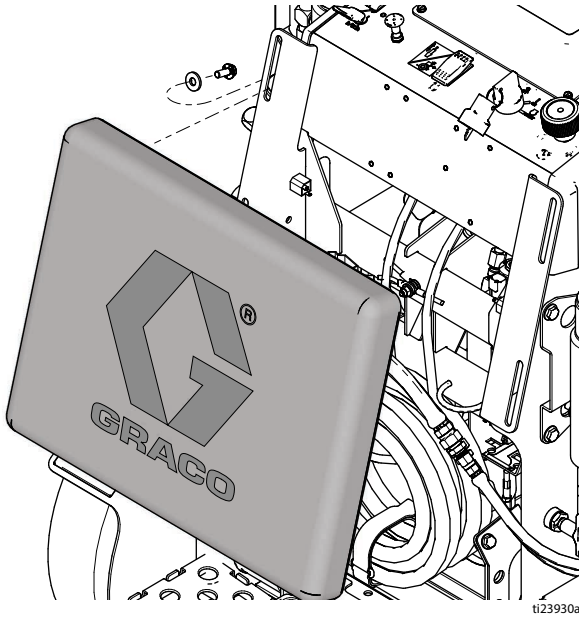

2. Remove six screws and control shroud.

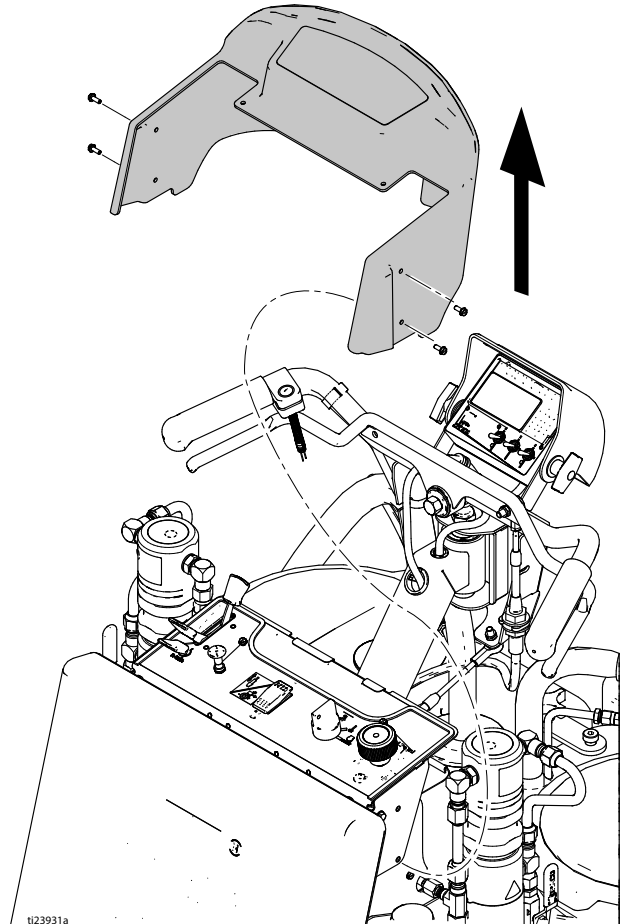

3. Apply parking brake. Raise front wheel off the ground and support frame on two jack stands.

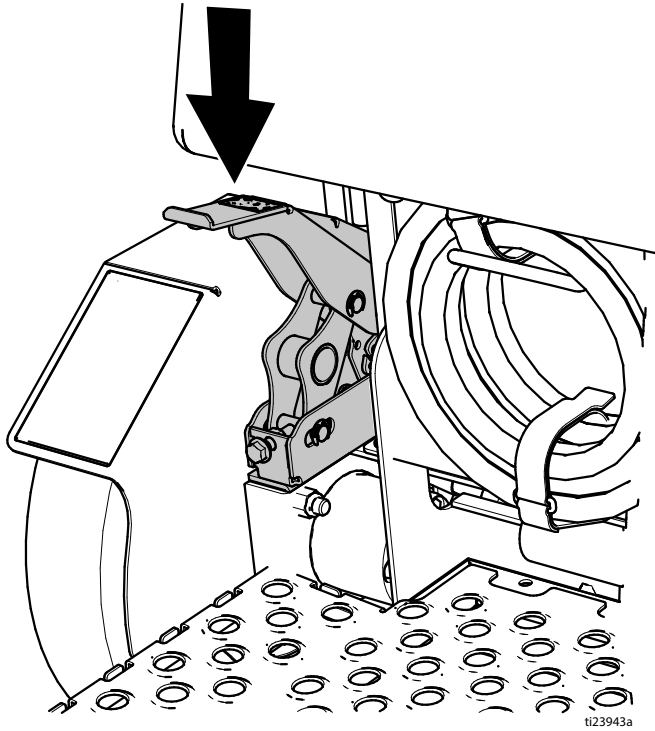

5. On front wheel fork, remove locknut (3) and ball joint (40) from fork. Remove ball joint (40) from cable (48) and save if not replacing. Loosen two nuts on cable (48) and remove from bracket.

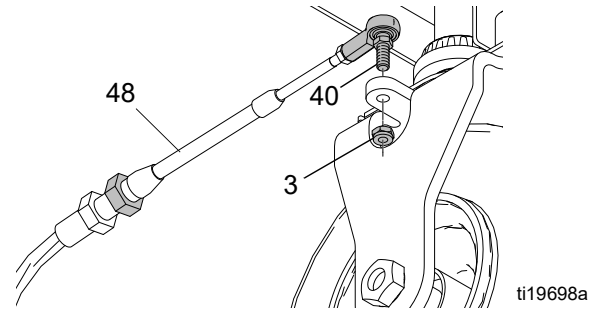

4. At the handlebar, remove locknut (3) and ball joint (40) from handlebar. Remove ball joint (40) from cable (48) and save if not replacing. Loosen two nuts on cable (48) and remove from bracket.

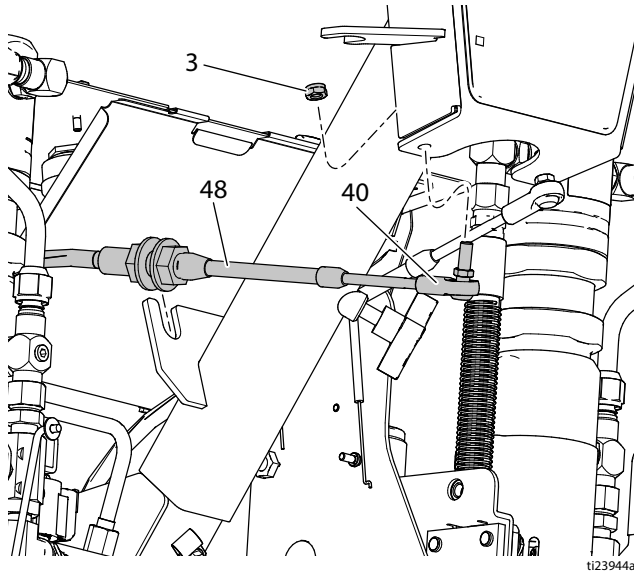

6. Note position of cable (48) and cut off all cable ties that retain cable to frame. Install new cable as old cable is removed to follow same route through frame.

Installation

1. Install new cable (48) by following same route as old cable is being removed.
2. At front wheel, adjust front nut on cable (48) to match the threads on the other side of front fork. Install cable (48) into frame bracket and tighten rear nut.

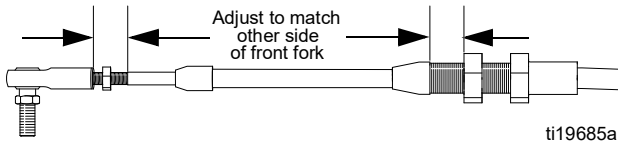

3. Install ball joint (40) onto cable (48) and match threads on other side of front fork. Install ball joint (40) into fork and tighten locknut (3).

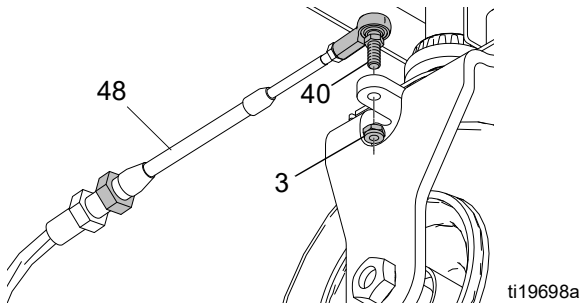

4. At handlebar, adjust front nut on cable (48) to match threads on other side of handlebar. Install cable (48) into bracket and tighten rear nut.

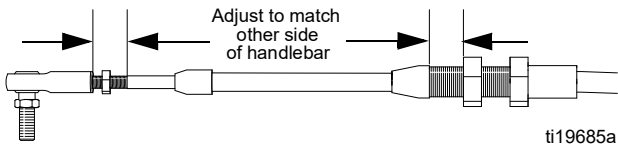

5. Install ball joint (40) onto cable (48) and match threads on other side of handlebar. Install ball joint (40) into handlebar and tighten locknut (3).

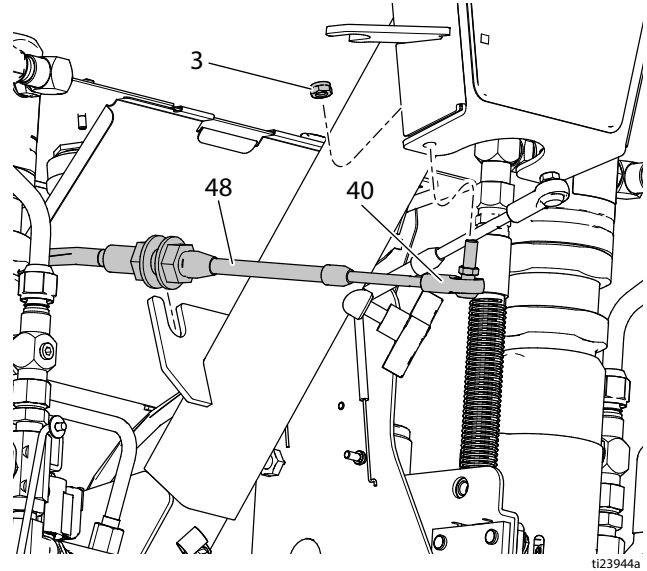

6. Verify that handlebar is aligned straight with frame. If misaligned, adjust nuts on cable (48) to straighten handlebar to frame.
7. At handlebar, loosen front nut on each cable (48) by three full rotations. Tighten rear nut on both cables three full rotations. Verify both front and rear nuts are tight against bracket.

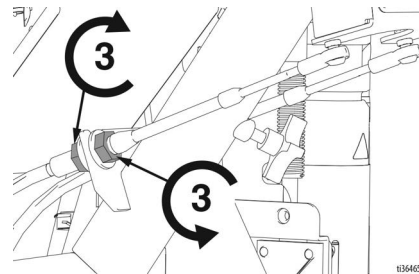

8. Verify that front wheel self-centers and that steering is tight and responsive. Ball joint (40) should rotate easily on the ball. If needed, remove ball joint from fork and adjust ball joint on cable (48).
9. Install pad and tighten four screws.
10. Remove jack stands and test drive sprayer to check steering. Adjust if needed. Install cable ties in locations noted in step 6 of Removal.
11. Verify straight line tracking and adjust if necessary (see Operation manual).
12. Install control shroud and tighten six screws.

Front Wheel Replacement



Removal

1. Apply parking brake. Raise front wheel off ground and support frame on two jack stands.

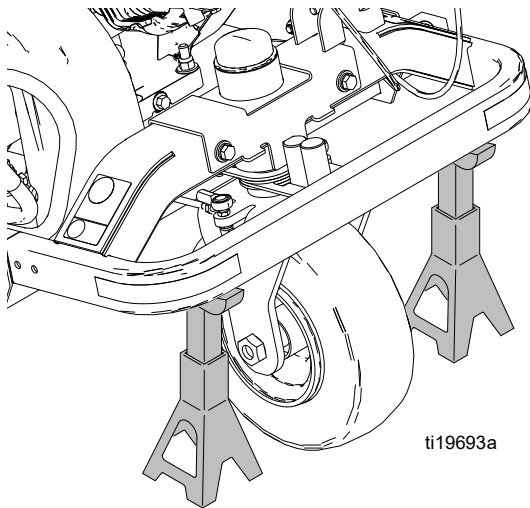

2. Remove locknut (39) from axle bolt (37) and remove axle bolt (37) from fork (34).

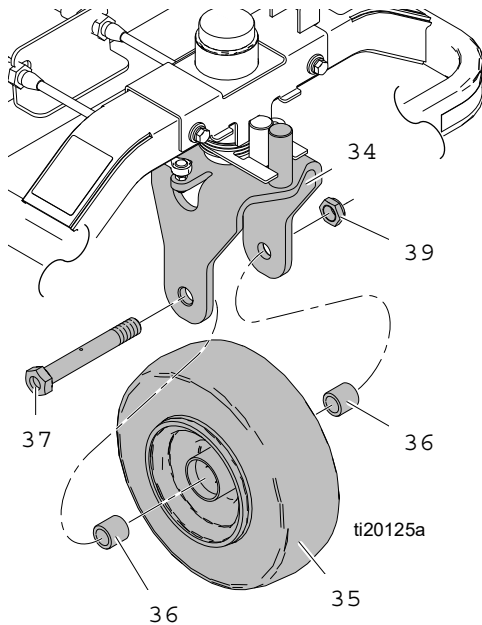

3. Remove two spacers (36) and wheel (35) from fork (34).

Installation

1. Insert two spacers (36) into wheel (35) and slide into fork (34).

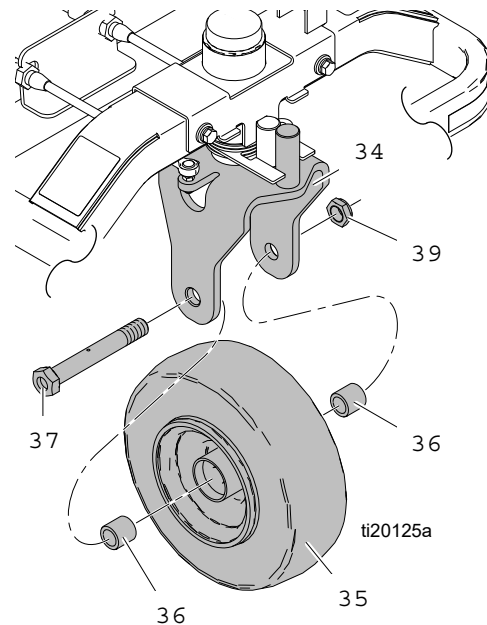

2. Insert axle bolt (37) through fork (34), spacers (36) and wheel (35).
3. Tighten locknut (39) onto axle bolt (37).
NOTE: When properly tightened, the wheel should not wobble to the left or right and should stop coasting quickly.
4. Remove jack stands and test drive sprayer to verify straight line tracking. Adjust if necessary (see Operation manual).

Parking Brake Service



Removal

1. Remove tire, wheel hub, and fender. See, **Wheel Motor Removal**, page 43.
2. Remove clips (13) from three pins (A). Remove pins and levers.
3. Use screwdriver to remove spring (15). Remove clip (13) and pin (B).
4. Replace damaged or worn parts.

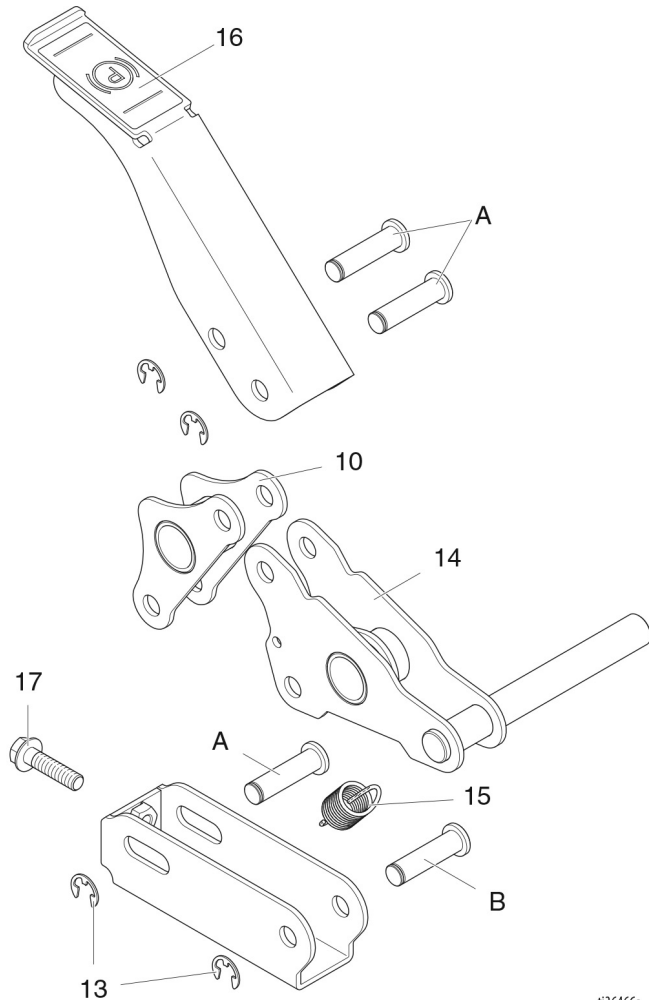

ti36466a

Installation

1. Install lever (14) with pin (B) and clip (13).
2. Use screwdriver to install spring (15).
3. Install levers (10, 16) with three pins (A) and clips (13).
4. Install fender, wheel hub, and tire. See, **Wheel Motor Removal**, page 43.
5. Adjust screw (17) to hold tire when brake lever (16) is depressed.

Rear Wheel and Wheel Motors



Rear Wheel Removal

1. Set LineStriper on blocks so wheels are off ground.

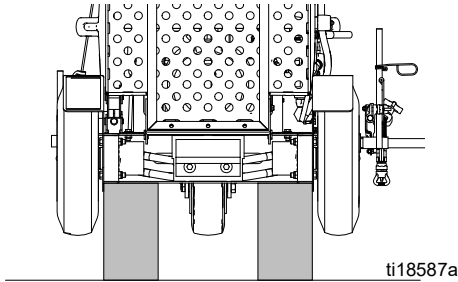

2. Remove four lug nuts (22) and wheel (16).

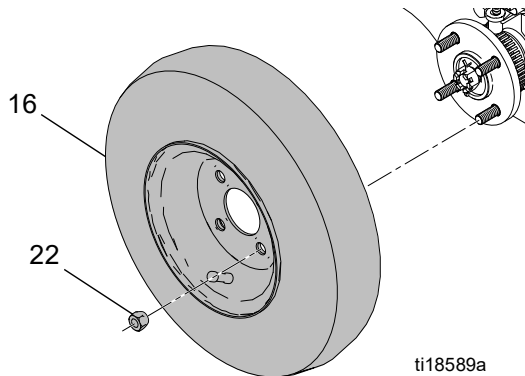

Rear Wheel Installation

1. Replace wheel and install lug nuts. Alternately tighten lug nuts opposite of each other.
2. Tilt LineStriper on side and remove blocks.

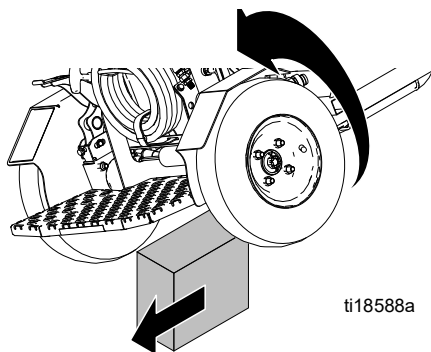

3. Inflate rear tires to 55 +/- 5 psi (380 +/- 34 kPa).

Wheel Motor Removal

1. Place jack under frame near wheel and raise jack.
2. Remove four lug nuts (22) and wheel (16).

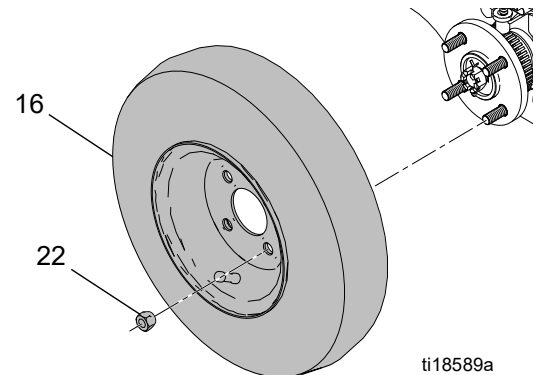

3. Remove pin (56), castle nut (21b) and wheel hub (22b). Wheel hub may require a wheel puller; not supplied by Graco.

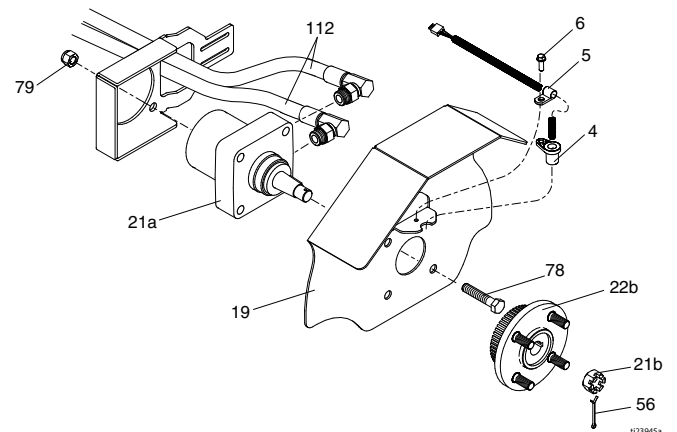

4. Remove screw (6) and distance sensor (4) with clamp (5).
5. Remove four bolts (78), lock nuts (79) from fender (19).
6. Disconnect two hydraulic hoses (112) from wheel motor (21a) and remove wheel motor.

Wheel Motor Installation

1. Connect two hydraulic hoses (112) to wheel motor (21a) and insert wheel motor (21a) into frame (1).
2. Install wheel motor (21a) and fender (19) with four bolts (78) and lock nuts (79).
3. Install distance sensor (4) and clamp (5) with screw (6) on to fender (19).

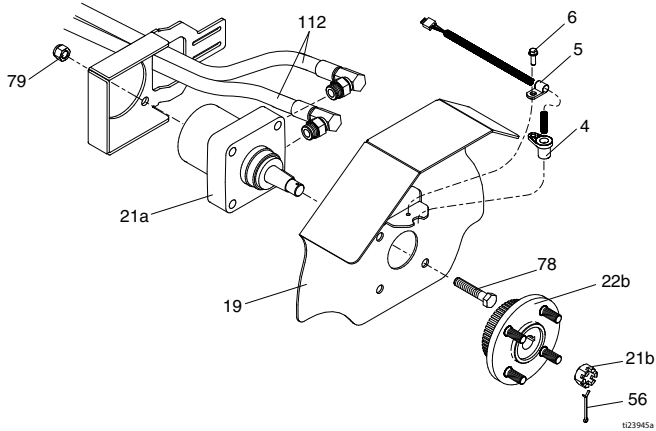

4. Install wheel hub (22b), castle nut (21b), and pin (56).
5. Install wheel (16) and four lug nuts (22). Alternately tighten lug nuts opposite each other.

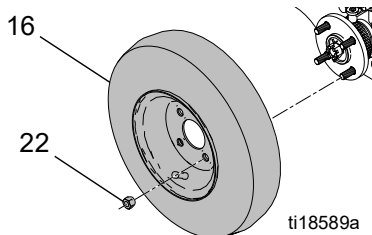

6. Purge hydraulic system. See **Hydraulic System Purging**, page 12.

Wheel Sensor Replacement

Removal

1. Loosen four screws and remove pad.

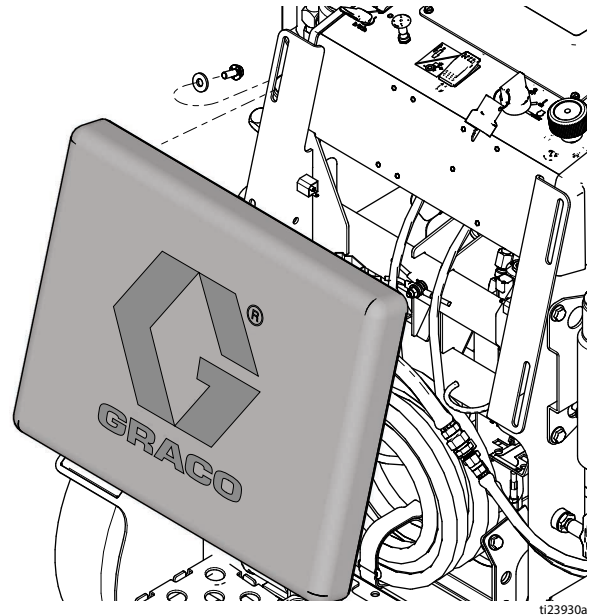

2. Place jack under frame on the side opposite of the brake and raise jack.
3. Remove four lug nuts (22) and wheel (16).

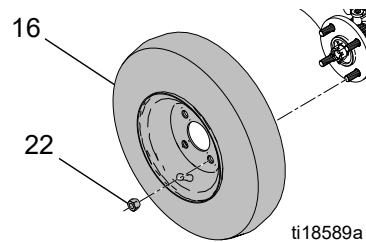

4. Disconnect wheel sensor connector from wire harness.

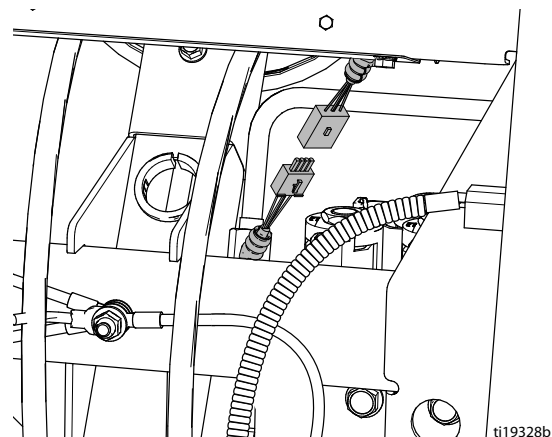

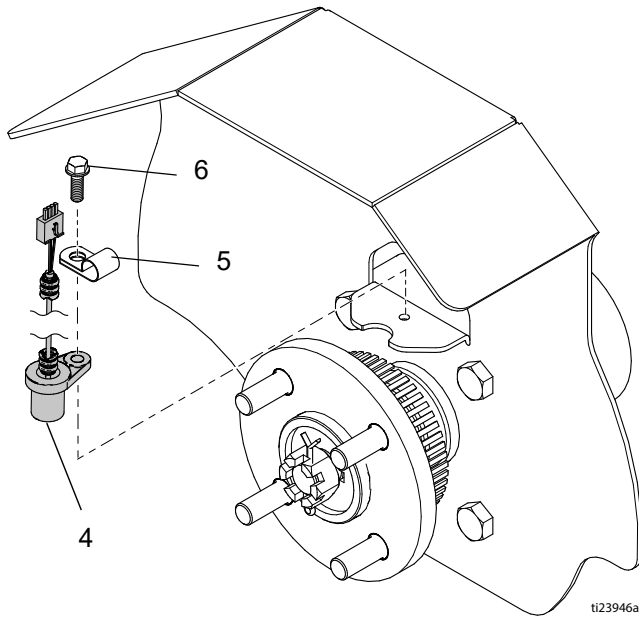

- Use wrench to remove screw (6), clamp (5), and wheel sensor (4).

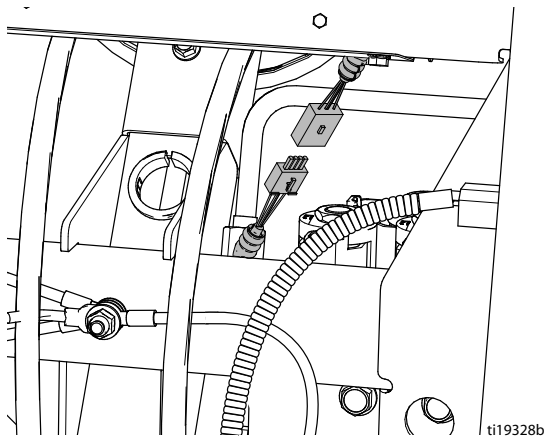

Installation

- Install wheel sensor (4) and clamp (5) with screw (6). See **Removal** step 5.
- Connect wheel sensor connector to wire harness.



- Verify sensor is working by turning on the main power switch and press   to display the **MEASURE** screen.

- Press gun trigger control button and rotate hub by hand exactly three turns.

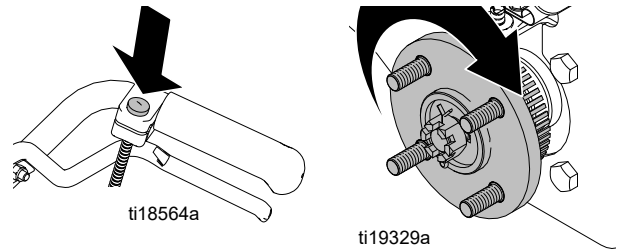

NOTE: Sensor is working properly if the measure display reads 12.3 to 12.7 ft (3.75 to 3.87 m).

- Install wheel (16) and four lug nuts (22).

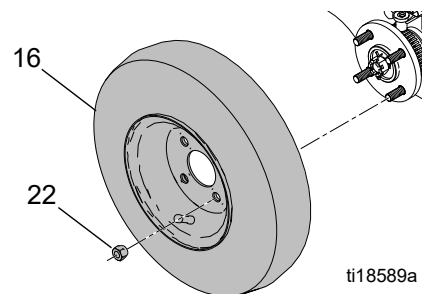

- Lower jack.
- Install pad and tighten four screws.

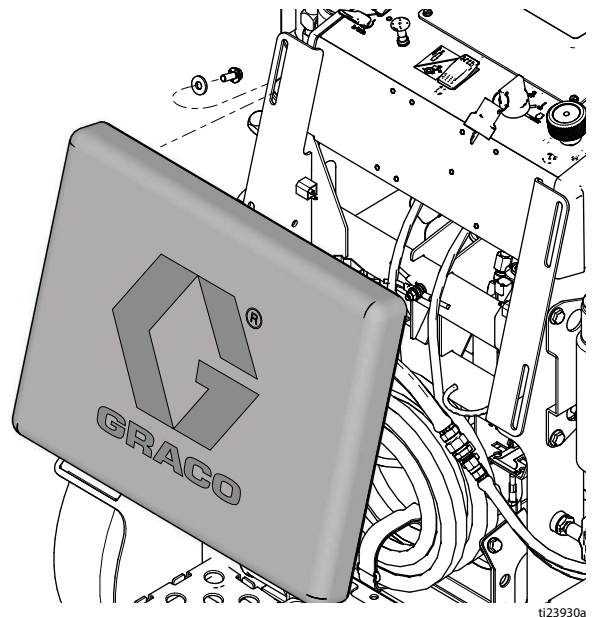

- Calibrate sprayer. See Operation manual.

Recycling and Disposal

Rechargeable Battery Disposal

Do not place batteries in the trash. Recycle batteries according to local regulations. In the USA and Canada, call 1-800-822-8837 to find recycling locations or go to www.call2recycle.org.

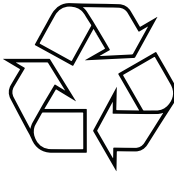
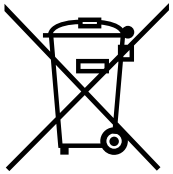

End of Product Life

At the end of the product's useful life, dismantle and recycle it in a responsible manner.

- Perform the **Pressure Relief Procedure**, page 9.
- Drain and dispose of fluids according to applicable regulations. Refer to the material manufacturer's Safety Data Sheet.
- Remove motors, batteries, circuit boards, LCDs (liquid crystal displays), and other electronic components. Recycle according to applicable regulations.
- Do not dispose of batteries or electronic components with household or commercial waste.



- Deliver remaining product to a recycling facility.

Troubleshooting

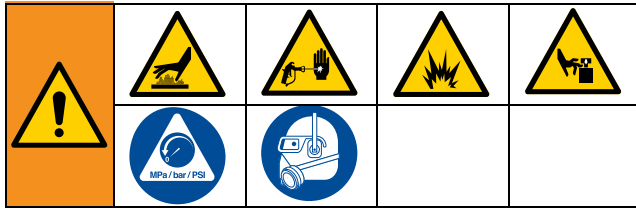

General

Problem	Cause	Solution
Engine will not crank	Battery is discharged.	Turn key switch to ON. Choke engine and pull recoil starter rope.
	Key switch is defective.	Replace key switch.
	Engine relay is defective.	Replace engine relay.
	Main wire harness is defective.	Replace wire harness, see Notes , page 51.
Engine cranks slow	Excessive hydraulic load. Engine clutch switch is on.	Turn engine clutch switch OFF.
Engine will not start	Engine is out of gas.	Refill gas tank. See engine manual.
	Fuel shut-off lever is OFF.	Move fuel shut-off lever to ON position.
	Engine oil level is low.	Check oil level and add oil if necessary. See engine manual.
	Engine is cold.	Use engine choke.
	Spark plug cable is disconnected or damaged.	Connect spark plug cable or replace spark plug cable.
	Key switch is defective.	Replace key switch.
	Main wire harness is disconnected or defective.	Reconnect or replace main wire harness
High engine speed at no load	Improperly adjusted high speed setting.	Reset high speed to 3600 - 3700 engine rpm at no load.
	Worn engine governor.	Adjust or replace engine governor.
Machine will not drive	Engine clutch switch is OFF.	Turn engine clutch switch ON.
	Hydrostatic drive bypass valve is open.	Close wheel motor bypass valve to engage drive. See Operation manual
	Hydraulic fluid is low.	Shut off striper and add fluid*.
	Drive cable is disconnected or broken.	Reconnect or replace cable.
	Clutch wire harness is disconnected or broken.	Reconnect or replace harness as necessary.
	Clutch does not work.	Replace clutch.
	Ground drive belt is worn or broken.	Adjust or replace ground drive belt.
	Ground Drive Pump is worn or not working.	Replace ground drive pump.
	Wheel motor(s) worn or not working.	Replace wheel motor.

Problem	Cause	Solution
Engine operates, but displacement pump does not operate	Engine clutch switch is OFF.	Turn engine clutch switch ON.
	Pump ball valve is OFF.	Turn pump ball valve ON.
	Pressure setting is too low.	Turn pressure adjusting knob clockwise to increase pressure. See Operation manual.
	Prime/drain valve is closed and system is pressurized.	Open prime/drain valve.
	Hydraulic fluid too low.	Shut off sprayer. Add fluid*.
	Oil reservoir belt is worn, broken, or off the pulley.	Replace oil reservoir belt, see Oil Reservoir Belt Replacement , page 11.
	Tip is clogged.	Reverse tip to clean. See Operation manual.
	Displacement pump piston rod is stuck due to dried paint.	Repair pump. See Pump manual.
	Hydraulic motor not shifting.	Set pump valve OFF. Turn pressure down. Turn engine OFF. Pry rod up or down until hydraulic motor shifts.
Displacement pump operates, but output is low on upstroke	Piston ball is not seating.	Service piston ball. See Pump manual.
	Piston packings are worn or damaged.	Replace packings. See Pump manual.
Displacement pump operates but output is low on downstroke and/or on both sides	Suction tube strainer is clogged.	Clean strainer.
	Suction tube air leak.	Tighten suction tube.
	Pressure setting is too low.	Increase pressure. See Operation manual.
	Fluid filter or tip is clogged or dirty.	Clean filter and tip. See Operation manual or gun manual.
	Engine speed is too low.	Increase throttle setting. See Operation manual.
	Intake valve ball is packed with material or is not seating properly.	Clean intake valve. See Pump manual.
	Pump packings are worn or damaged.	Replace pump packings. See Pump manual.
	Large pressure drop in hose with heavy materials.	Use larger diameter hose and/or reduce overall length of hose. Use of more than 100 ft x 1/4 in. hose significantly reduces performance of sprayer. Use 3/8 in. hose for optimum performance.
	Oil reservoir hydraulic filter is dirty or clogged.	Change hydraulic filter and hydraulic oil.
	Intake line to pump inlet is not tight.	Tighten intake line to pump inlet.
Pump is difficult to prime	Suction tube strainer is clogged.	Clean strainer
	Suction tube air leak.	Tighten suction tube
	Drain line to paint hopper is clogged.	Clean drain line
	Intake valve is leaking.	Clean intake valve. Be sure ball seat is not nicked or worn and that ball seats well. Reassemble valve.
	Pump packings are worn.	Replace pump packings. See Pump manual.
	Paint is too thick.	Thin the paint according to supplier recommendations.
	Engine speed is too high.	Decrease throttle setting before priming pump. See Operation manual.

Problem	Cause	Solution
Low stall or run pressure shown on display	Pressure setting too low.	Turn pressure adjusting knob clockwise to increase pressure. See Operation manual.
	New pump or new packings.	Pump break-in period takes up to 100 gallons of material.
	Faulty transducer.	Replace transducer.
Excessive paint leakage into throat packing nut	Throat packing nut is loose.	Remove throat packing nut spacer. Tighten throat packing nut just enough to stop leakage.
	Throat packings are worn or damaged.	Replace packings. See Pump manual.
	Displacement rod is worn or damaged.	Replace rod. See Pump manual.
Fluid is spitting from gun	Air in pump or hose.	Check and tighten all fluid connections. Reprime pump. See Operation manual.
	Tip is partially clogged.	Clear tip. See Gun manual.
	Fluid supply is low or empty.	Refill fluid supply. Prime pump. See Operation manual. Check fluid supply often to prevent running pump dry.
Excessive leakage around hydraulic motor piston rod wiper	Piston rod seal worn or damaged.	Replace hydraulic motor piston rod wiper and seal.
Sprayer overheats	Paint buildup on hydraulic components.	Clean hydraulic components.
	Hydraulic oil level is low.	Fill with hydraulic oil. See Operation manual.
Excessive hydraulic pump noise	Low hydraulic fluid level.	Shut off sprayer. Add fluid*.
	Pulleys loose on hydraulic pumps.	Remove belt guard. Check and tighten loose pulley.
Display does not turn on	Key switch is not turned on.	Turn key switch to ON position.
	Main fuse is blown.	Replace fuse. See Fuse Replacement , page 35.
	Cable between display and main board is disconnected or damaged.	Reconnect or replace cable.
	Display board failure.	Replace display board.
Gallon (liter) counter not adding fluid volume	Fluid pressure not high enough.	Must be over 800 psi (55 bar) for counter to add.
	Broken or disconnected pump counter wire, both pumps.	Check wires and connections. Replace any broken wires.
	Missing or damaged magnet, both pumps.	Reposition or replace magnet on pump, see Parts manual (Pump parts) for magnet location.
	Bad sensor, both pumps.	Replace sensor. See Hydraulic Motor Replacement , page 22.
Distance not adding properly (MEASURE mode will be inaccurate and speed will be wrong)	Machine not calibrated.	Perform calibration procedure. See Operation manual.
	Rear tire pressure is too low or too high.	Adjust tire pressure to 55 +/- 5 psi (380 +/- 34 kPa).
	Gear teeth missing or damaged (right side when standing on platform).	Replace distance gear/wheel hub. See Rear Wheel and Wheel Motors , page 43.
	Distance sensor is loose or broken.	Reconnect or replace sensor. See Wheel Sensor Replacement , page 44.
Mils not calculating or calculates wrong	Distance sensor.	See "Distance not adding properly".
	Gallon counter.	See "Gallon (liter) counter not adding fluid volume".
	Line width not entered.	Set line width for each gun. See Operation manual.
	Bad or damaged display board.	Replace display board.

Problem	Cause	Solution
Pressure control knob does not rotate	Knob is jammed.	Pull back cover where remote cable connects to hydraulic pump and turn counter-clockwise (ccw) until free.
Pressure control knob rotates freely with no pressure change	Set screw at hydraulic pump connection is loose.	Remove cover and adjust cable. See Oil Reservoir Pump Replacement , page 15, step 4.
	Remote cable is broken or disconnected.	Replace or reconnect cable. See Oil Reservoir Pump Replacement , page 15, step 4.
Gun does not trigger	Engine clutch switch is not turned ON.	Turn engine clutch switch ON.
	Gun selector switch is OFF.	Turn gun selector switch ON.
	Display is in AUTO MODE and speed is less than 0.7 mph (1.1 kph).	Increase ground speed to be greater than 0.7 mph (1.1 kph).
	System pressure is too low.	Increase fluid pressure up to at least 1000 psi.
	Gun cable is disconnected or broken.	Reconnect or replace cable.
	Disconnected or broken wires from control board to solenoid.	Reconnect or replace wires.
Gun triggering is slow	Gun cable is pinched or kinked.	Change gun cable routing or replace cable.
	System pressure is too low.	Increase fluid pressure up to at least 1000 psi.
AUTO Mode		
Line spacing is not accurate	Wrong line pattern loaded	Reload the correct pattern.
	Machine not calibrated	Perform calibration routine (see Operation manual).
Gun does not trigger	See Gun does not trigger , page 50.	
PARKING LAYOUT Mode		
Gun does not apply dots	Gun selector switch is OFF	Turn gun selector switch ON.
	Dot size setting is too small	Increase dot size.
	Pressure is too low	Increase pressure to 1000 psi.

* Use only Graco approved hydraulic fluid 169236 (5 gallons / 18.9 liter) or 207428 (1 gallon / 3.8 liter)

Parts

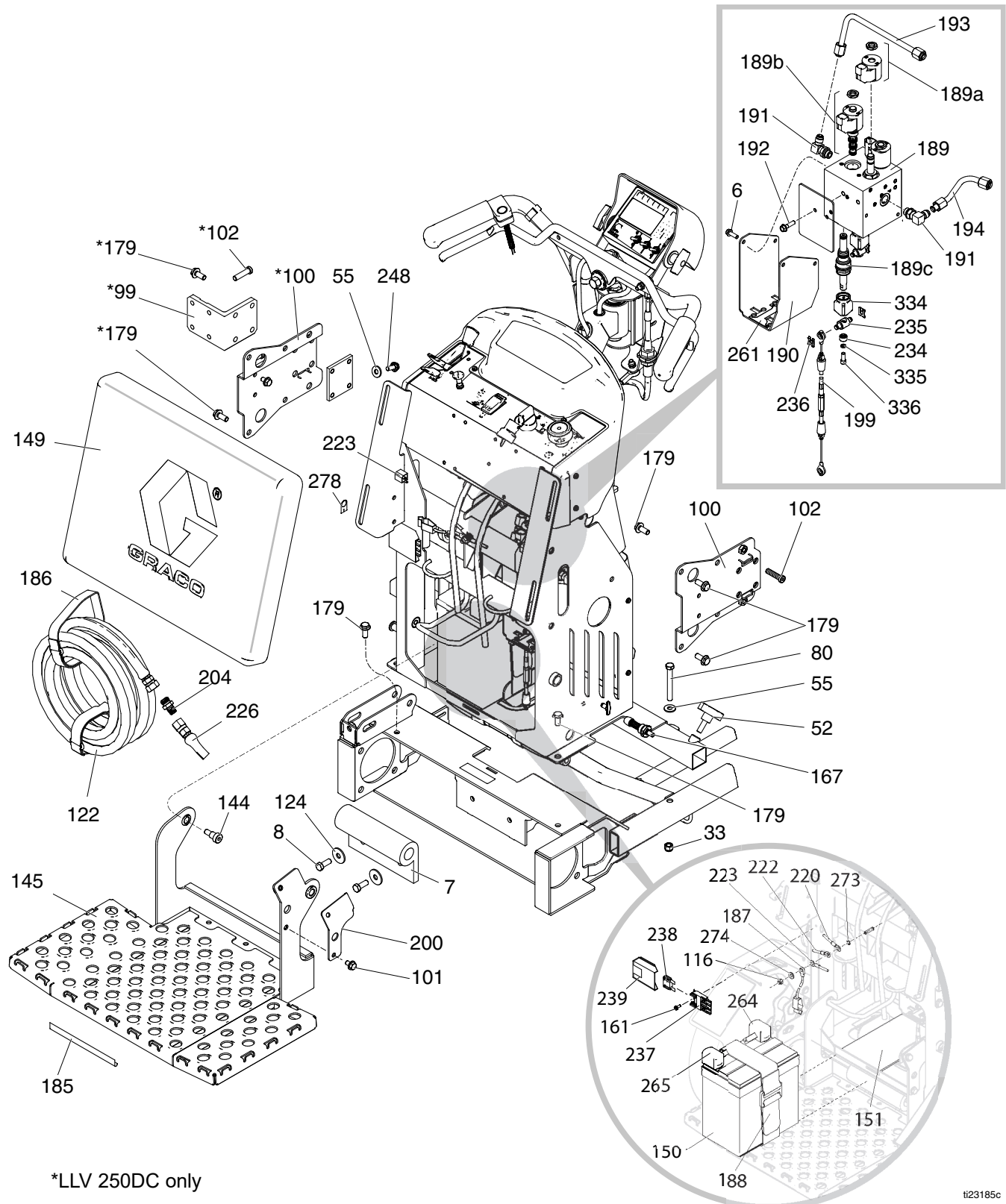

*LLV 250DC only

ti23185c

Parts List

Ref.	Part	Description	Qty.	Ref.	Part	Description	Qty.
6	260212	SCREW, hex washer hd, thd form	4	189c	24V560	KIT, repair, actuator, piston (includes 234, 235, 236, 334, 335, 336)	1
7	16M279	BUMPER, platform	1				
8	100101	SCREW, cap, hex hd	2	190	16W373	BRACKET, manifold, hydraulic, gun	1
33	101566	NUT, lock	2				
52	111145	KNOB, pronged	2	191	116829	FITTING, 90 degree	2
55	100023	WASHER, flat	6	192	15C753	SCREW, mach, hex wash hd	2
80	120721	SCREW, cap, 3/8-16, hexhd	2	193	24M625	TUBE, supply, hydraulic	1
99	16W544	BRACKET, mount, second pump, LL250, paint	1	194	24M626	TUBE, supply, hydraulic	1
100	16M717	BRACKET, mount, pump, LL250, paint	2	199	24N492	KIT, repair, gun cable (includes 236)	1
101	111801	SCREW, cap, hex hd	1	200	16N380	BRACKET, pin ramp	1
102	107210	SCREW	8	204	196177	ADAPTER, nipple	2
116	102040	NUT, lock, hex	1	220	16X078	HARNESS, wire	1
122				222	16N541	WIRE, negative battery	1
	*191239	HOSE, coupled 3/8 x 11 ft	2	223	16N540	HARNESS, light connection	1
	**124884	HOSE, coupled 3/8 x 22 ft	1	226	245798	KIT, repair, hose	3
124	108851	WASHER, flat	2	234	16W656	BUSHING, manifold, cable, gun	3
144	126108	SCREW, shoulder, skt hd	2	235	16W655	ADAPTER, manifold, cable, gun	3
145	24L909	FRAME, platform, painted, LL250	1	236	126111	RETAINER, circlip, external, 8mm	6
149	278421	PAD, foam	1	237	126095	HOLDER, fuse	1
150	115753	BATTERY, 33 AH, sealed	1	238	126096	FUSE, 30A	1
151	801972	PAD, battery	1	239	126097	COVER, fuse holder	1
161	118444	SCREW, mach, slot hex wash hd	1	248	110963	SCREW, cap, flange head	4
167	24D618	PIN, handle, Grindlazer	1	261	16Y454	LABEL, gun indicator	1
179	111192	SCREW, cap flang hd	12	264	801958	PROTECTOR, terminal, red	1
185	290159	LABEL, reflective	1	265	801959	TERMINAL, protector, black	1
186	114271	STRAP, retaining	2	273	558685	WASHER, 1/4 external tooth lock	1
187	237686	WIRE, ground assembly w/ clamp	1	274	110755	WASHER, plain	1
188	126071	STRAP, battery	1	278	16P138	LABEL, energy source	2
189	16W372	MANIFOLD, hydraulic, three pis- ton	1	334	16P450	BELLOWS, constant volume	3
189a	24N577	KIT, repair, coil, hydraulic manifold	1	335	105510	WASHER, lock, spring, (hi collar)	3
189b	24N490	KIT, repair, solenoid (includes 189a)	1	336	126242	SCREW, cap, sch	3
					* LLV 250DC		
					** LLV 250SPS		

Parts

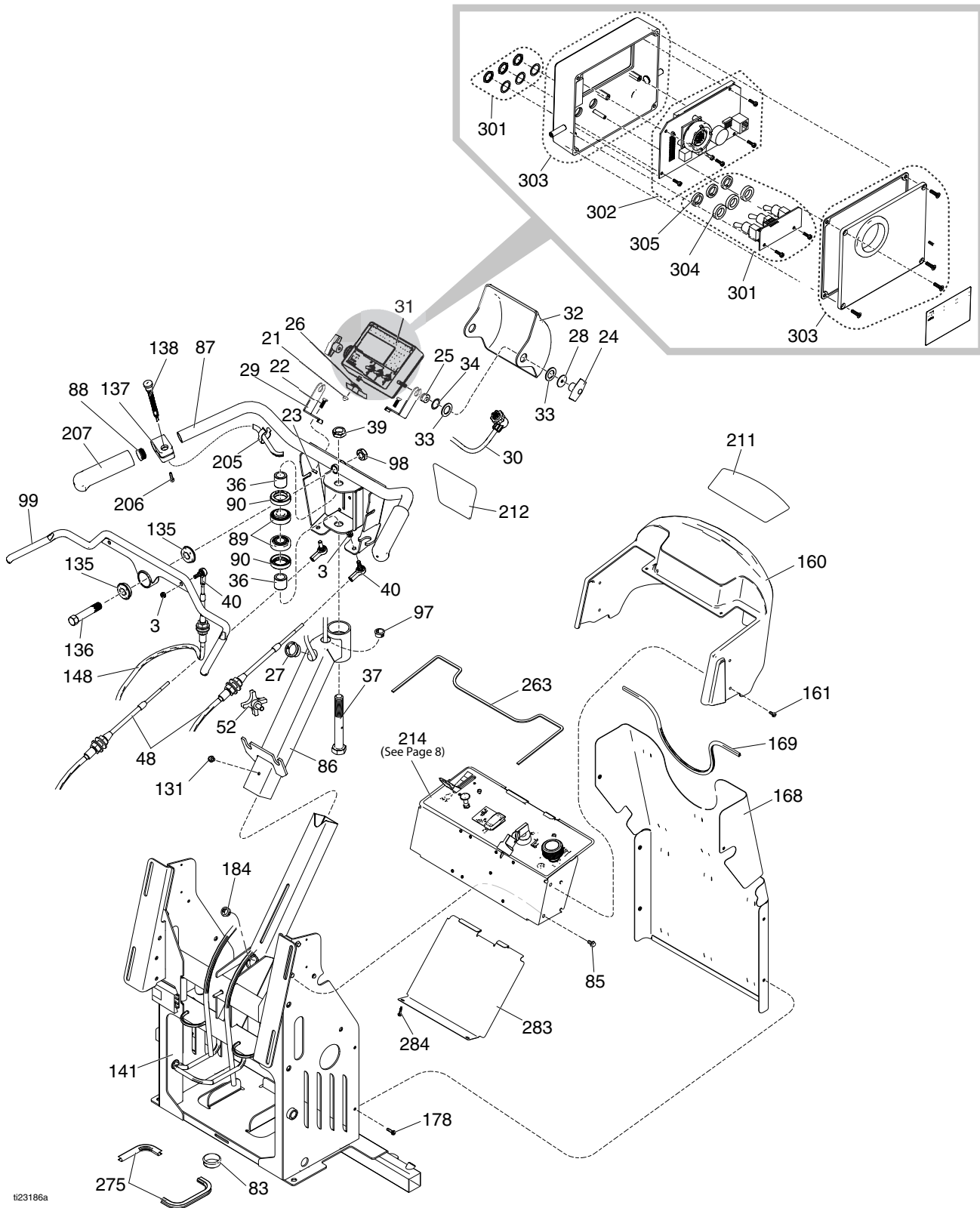

Parts List

Ref.	Part	Description	Qty.	Ref.	Part	Description	Qty.
3	102393	NUT, lock	3	99	24M196	HANDLE, control, forward/reverse	1
21	116424	NUT	1	131	112798	SCREW, thread forming, hex hd	1
22	100022	SCREW, cap, hex hd	2	135	119532	BEARING, flanged	2
23	102040	NUT, lock	2	136	15E780	PIN, fork	1
24	115480	KNOB, T-handle	2	137	15K162	BLOCK	1
25	118886	GROMMET, isolator	2	138	16N401	SWITCH, push button	1
26	108868	CLAMP	1	141	16M702	FRAME, upright, LL250, paint	1
27	127372	BUSHING	1	148	16M274	CABLE, forward/reverse, push/pull	1
28	159346	WASHER	2	160	16X069	COVER, display, LL250, painted	1
29	16X072	BRACKET, control, mount	2	161	118444	SCREW, mach, slot hex wash hd	6
30	24U233	CABLE, 18 conductor	1	168	24N496	KIT, repair, shield, paint (includes 169)	1
31	24U234	BOX, control	1	169	114225	TRIM, edge protection	1
32	17B211	COVER, control box, LL250, painted	1	178	107439	SCREW, mach, hex hd	6
33	116477	WASHER, flat, nylon	4	184	127372	BUSHING, strain relief	1
34	116038	WASHER, wave, spring	2	205	178342	CLIP, spring	1
36	193658	SPACER, seal	2	206	C20004	SCREW, cap	1
37	113471	SCREW, cap, hex hd	1	207	114659	GRIP, handle	2
39	112405	NUT, lock	1	211	16X127	LABEL, brand, LineLazer, dash	1
40	125792	BALL, joint, rod end	3	212	16X125	LABEL, brand, LineLazer, top	1
48	16M273	CABLE, steering push/pull, LL250	2	214	24U235	PLATE, control, complete, Honda	1
52	111145	KNOB, pronged	1		24U235V	PLATE, control, complete, Vanguard	1
83	113677	BUSHING, nylon	3	263	16N548	GASKET, control	1
85	107257	SCREW, thd forming	6	275	126215	TRIM, edge, protection	1
86	24N494	KIT, repair, support, steering (includes 89, 90)	1	283	16P554	PLATE, cover, control board	1
87	24L900	BAR, handle, LL250	1	284	16M007	SCREW, drill, hex washer head	2
88	120151	RETAINER, caplug	2	301	24V564	KIT, board, toggle switch	1
89	113485	BEARING, cup/cone	2	302	24V565	KIT, display, repair	1
90	115503	SEAL, grease	2	303	24V566	KIT, switch, membrane	1
97	119569	BUSHING, strain relief	1	304	16Y924	SPACER, toggle switch	3
98	119554	NUT, lock, nylon, thin pattern	1	305	127543	SEAL, toggle switch	3

Parts (24U235/24U235V Control Panel)

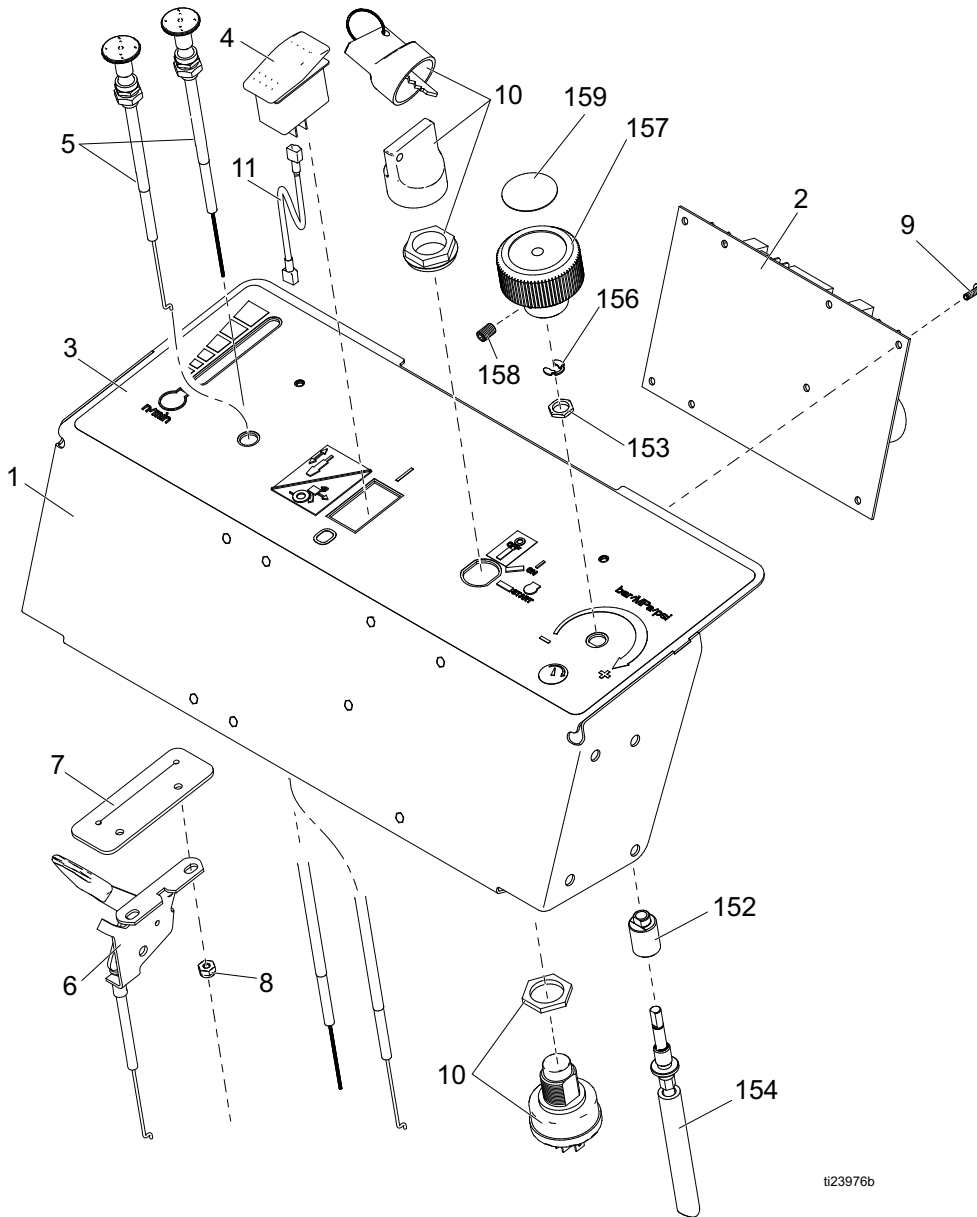

ti23976b

Parts List

Ref.	Part	Description	Qty.	Ref.	Part	Description	Qty.
1	16X077	PLATE, control, LL250	1	11	17C064	WIRE, positive	1
2	24V561	KIT, repair, control board (includes 9)	1	152	16Y411	BUSHING, pressure control mount	1
3	16X074	LABEL	1	153	119775	NUT, panel	1
4	17C063	SWITCH, rocker, SPST	1	154	24V563	SHAFT, flexible	1
5	16M508	CABLE, choke, Honda	1	156	115999	RING, retaining	1
	19F998	CABLE, choke, Vanguard	1	157	16Y408	KNOB, pressure control	1
6	16M509	CONTROL, throttle	1	158	101962	SCREW, set, sch, 1/4-20	1
7	16N549	GASKET, throttle	1	159	15A464	LABEL, control	1
8	109466	NUT, lock, hex	2				
9	111839	SCREW, mach, pnh, sems	8		24U235	PLATE, control (includes 1, 2, 3, 4, 5, 6, 7, 8, 9, 10, 11)	1
10	16X075	SWITCH, ignition	1				

Parts

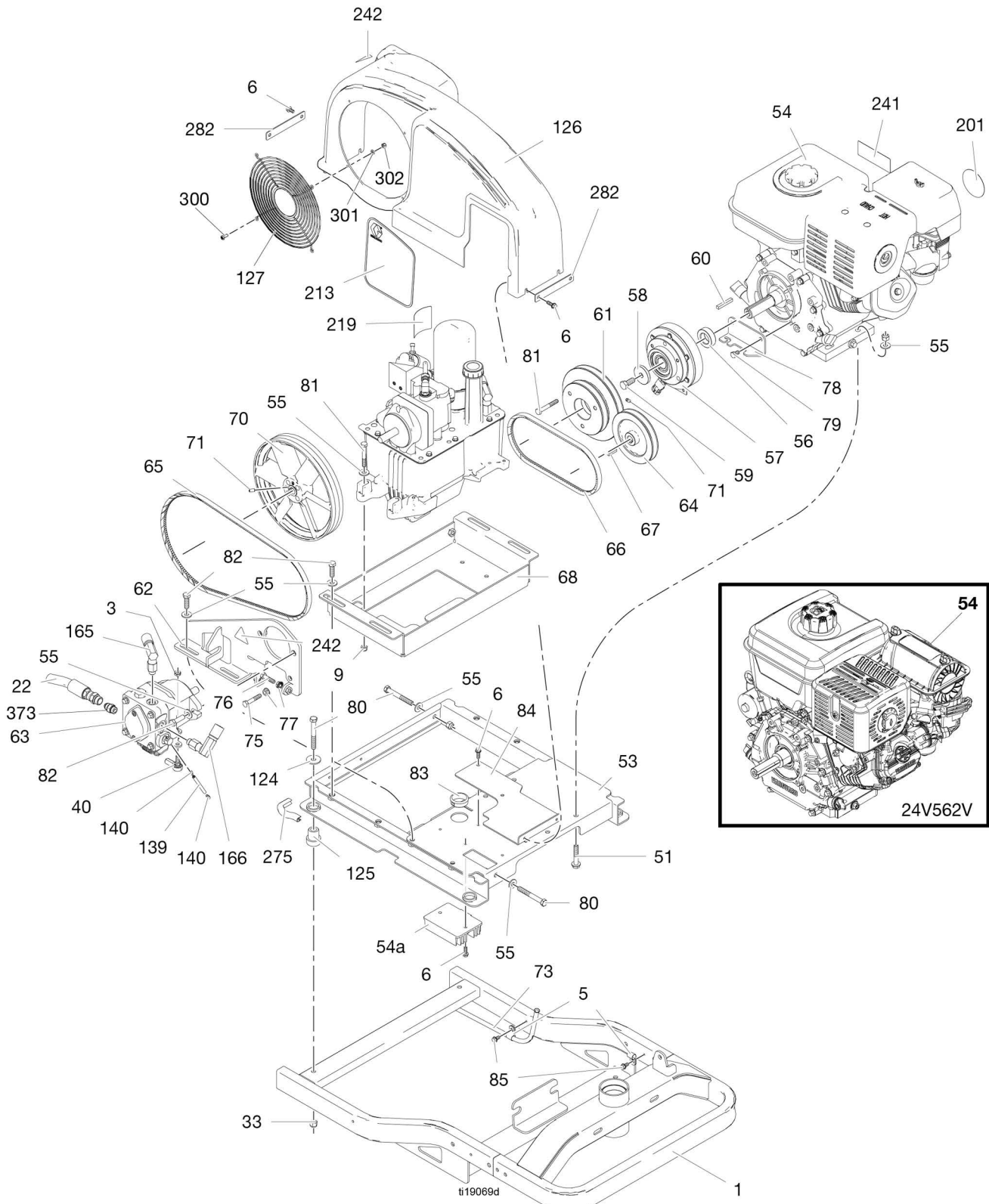

Parts List

Ref.	Part	Description	Qty.	Ref.	Part	Description	Qty.
1	24L896	FRAME, painted, LL250	1	78	16M082	BRACKET, clutch, anti-rotation	1
3	102393	NUT, lock	1	79	112406	SCREW, cap, hex hd	2
5	108868	CLAMP, wire	1	80	120721	SCREW, cap, 3/8-16, hexhd	7
6	260212	SCREW, hex washer hd, thd form	8	81	108481	SCREW, cap, hex hd	5
9	111040	NUT, lock, insert, nylock, 5/16	2	82	100004	SCREW, cap, hex hd	6
22	18H276	KIT, hose	2	83	113677	BUSHING, nylon	1
33	101566	NUT, lock	3	84	16M715	BRACKET, mount, belt guard, LL250	1
40	125792	BALL, joint, rod end	1	85	107257	SCREW, thd forming	1
51	114982	SCREW, cap, flng hd	4	124	108851	WASHER, plain	4
53	16M072	FRAME, mount, engine, paint	1	125	119695	DAMPENER, engine mount	4
54	24V562	KIT, repair, engine, GX390 (includes 54a, 60, 202, 241)	1	126	24N498	KIT, repair, guard, belt (includes 6, 127, 242, 282, 300)	1
	25P364	KIT, repair, engine, GX390 (includes 54a, 60, 202, 241) (China only)	1	127	117284	GRILL, fan guard	1
	24V562V	KIT, repair, engine, Vanguard 14HP ES (includes 60, 241)	1	139	15R309	ROD, standoff, 1/4 in. od x 2.75 in. LG	1
54a	24N502	KIT, repair, rectifier, voltage	1	140	111006	SCREW, cap	2
55	100023	WASHER, flat	11	158	101962	SCREW, set, 1/4-20	2
56	16M075	SPACER, clutch, 1.00 id x .5 thk	1	166	16M276	HOSE, coupled, feed line, LL250	2
57	125877	CLUTCH, electric, LL250	1	190	124941	FITTING, long elbow, hydraulic	1
58	16M076	WASHER, 7/16 id x .25 thk	1	191	116829	FITTING, 90 degree	1
59	116596	SCREW, cap, hex head, Honda	1	202	126072	KIT, Honda remote choke (not shown)	1
	116645	SCREW, cap, hex head, Vanguard	1	213	16X126	LABEL, brand, LineLazer, DC, side	1
60	125919	KEY, parallel, square, 1/4	1	219	189892	LABEL, Graco logo	1
61	16M077	PULLEY, double	1	241▲	194126	LABEL, warning	1
62	24N499	KIT, repair, bracket, hydro pump (includes 75, 76, 77, 242)	1	242▲	16M768	LABEL, pinch hazard iso	2
63	247930	KIT, repair, hydraulic pump	1	275	126215	TRIM, edge, protection	1
64	16M078	PULLEY, 5 o.d. x 15mm	1	282	16P547	PLATE, backer, belt guard, paint	2
65	125793	BELT, vee, tri-power, AX44	1	300	260387	SCREW, pan hd, x recess	4
66	125876	BELT, vee, tri-power, AX26	1	301	116876	WASHER, flat	4
67	117222	KEY, square	1	302	116969	NUT, lock	4
68	16M084	TRAY, hyd reservoir, LL250, paint	1	337	129636	SPRING	1
70	16U205	PULLEY, fan	1	373*	2004330	FITTING, adapter, JIC to orb	2
71	120087	SCREW, set, 1/4 in. x 1/2 in.	2				
75	100678	SCREW, cap hex hd	1				
76	100521	SCREW, cap hex hd	1				
77	110996	NUT, hex, flange head	2				

* Included in Kit 18H276.

▲ Replacement warning labels may be ordered free of charge.

Parts

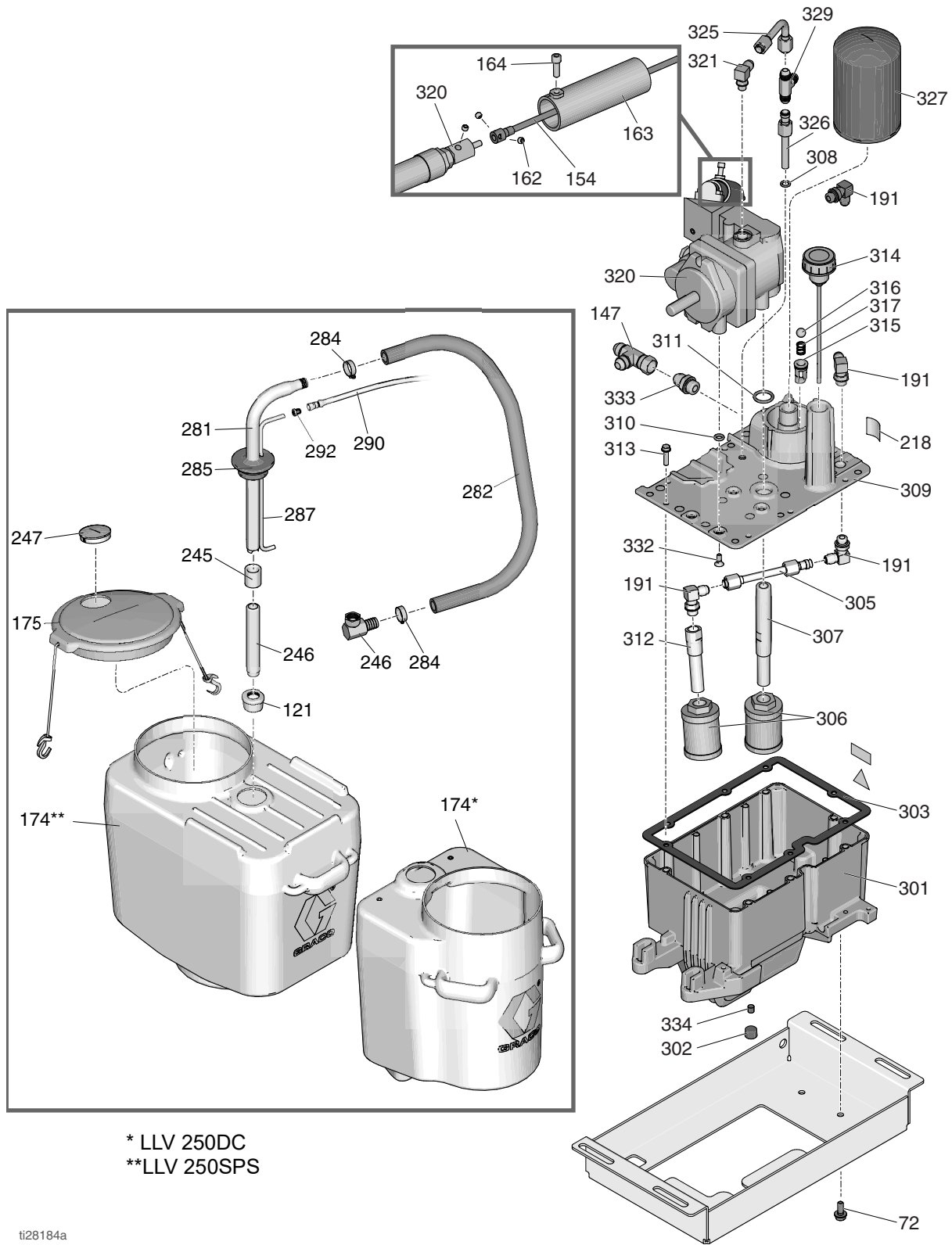

ti28184a

Parts List

Ref.	Part	Description	Qty.	Ref.	Part	Description	Qty.
52	111145	KNOB, pronged	2	302	101754	PLUG, pipe	1
72	125794	SCREW, taptite, hex washer hd	2	303	120604	GASKET, reservoir	1
121	181072	KIT, repair, strainer	2	305	24K967	TUBE, supply, hydraulic	1
128	16X081	BRACKET, dual tank retaining	2	306	116919	FILTER	2
144	126108	SCREW, shoulder, socket head	2	307	15E587	TUBE, suction	1
147	124770	FITTING, #8 jic tee, swivel	1	308	154594	PACKING, o-ring	1
154	24V563	KIT, repair, shaft, flexible (includes 162)	1	309	16M160	COVER, reservoir, LL250, painted	1
162	112303	SCREW, set, sch	2	310	107188	PACKING, o-ring	4
163	15C958	GUARD, control, pressure	1	311	156401	PACKING, o-ring	1
164	112166	SCREW, cap, sch	1	312	16M112	TUBE, suction, hydraulic, LL250	1
174				313	119426	SCREW, mach, hex washer hd	8
	*278720	RESERVOIR, 15 gallon	2	314	120726	CAP, breather, filler	1
	**278452	RESERVOIR, 25 gallon	1	315	198841	RETAINER, ball, pressure bypass	1
175	24V687	KIT, pail, lid assembly	2	316	100084	BALL, metallic	1
191	116829	FITTING, 90 degree	4	317	116967	SPRING, compression	1
217	15K440	LABEL, brand, GH/EH cooling	1	320	16X083	KIT, repair, pump, 250SPS (includes 310, 311, 332)	1
218	16P142	LABEL, hydraulic only icon	1	321	110792	FITTING, elbow, male, 90 deg	1
245	114967	COUPLING, pipe, 1 in.	2	325	17A581	KIT, repair, case drain (includes 308)	1
246	189674	TUBE, intake	2	326	17A582	TUBE, hydraulic case, drain	1
247	127375	PLUG, 3"	2	327	246173	KIT, repair, oil filter (includes 315, 316, 317)	1
254▲	189285	LABEL, caution	1	329	127686	FITTING, tee	1
281	15F149	TUBE, suction	2	332	117471	SCREW, mach, hex flat head	4
282	194306	HOSE, fluid	2	333	120184	FITTING, hydraulic	1
283	198119	FITTING, elbow, barbed	2	334	116618	MAGNET	1
284	101818	CLAMP, hose	4				
285	278722	GASKET, pail	2				
287	16X071	TUBE, drain line	2				
290	248008	HOSE, cpld, 1/4 in. x 44 in.	2				
292	196180	BUSHING	2				
301	15J513	TANK, reservoir, blue	1				

▲ Replacement warning labels may be ordered free of charge.

* LLV 250DC

** LLV 250SPS

Parts (Front Wheel)

Series A

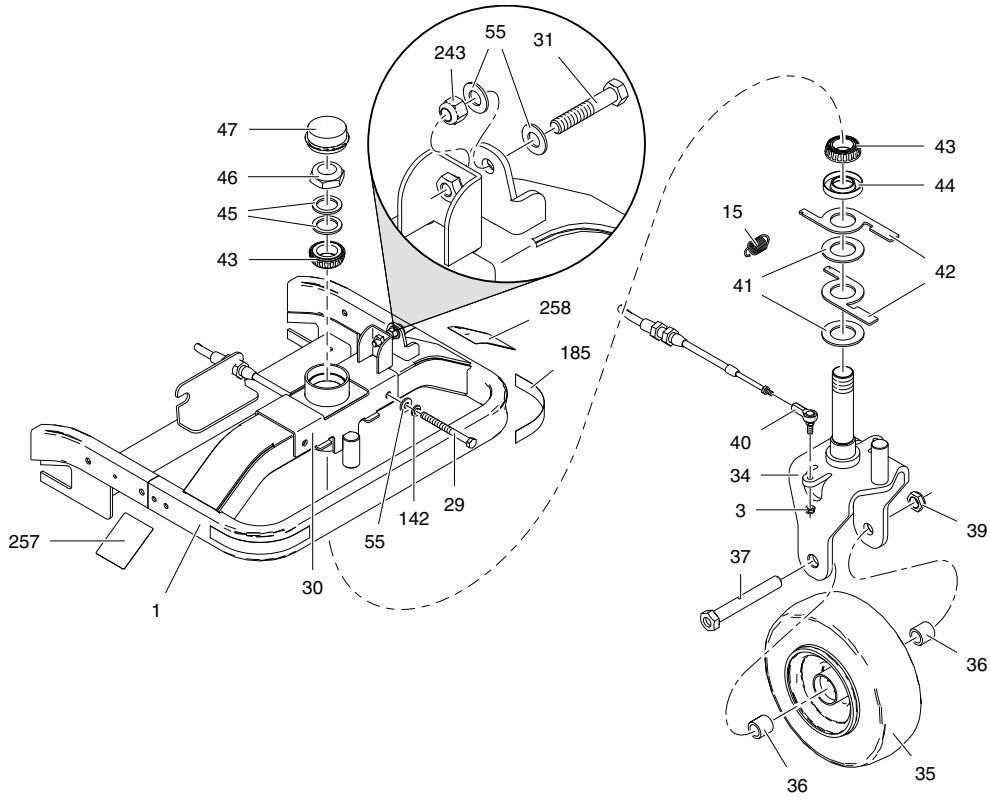

Series B

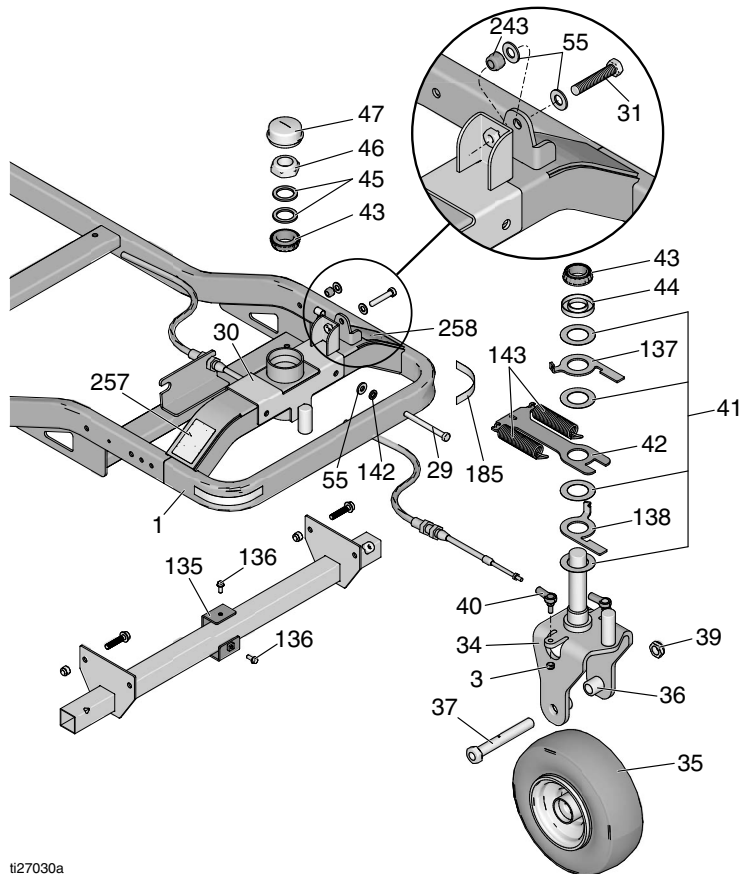

Parts List - Series A

Ref.	Part	Description	Qty.
1	24L896	FRAME, painted, LL250	1
3	102393	NUT, lock	2
15*	15V264	SPRING, extension	1
29	113743	SCREW, cap, hex hd	2
30	24L902	ADJUSTER, caster, weldment, LL250	1
31	126204	SCREW, cap, hex hd	1
34	24L897	CASTER, painted, LL250	1
35	16W284	WHEEL, foam filled (LL250 SPS, DC)	1
36	193658	SPACER, seal	2
37	113471	SCREW, cap, hex hd	1
39	112405	NUT, lock	1
40	125792	BALL, joint, rod end	2
41*	125893	WASHER, thrust, 1-1/2 in. id	2
42*	16M267	LEVER, self centering, LL250	2
43	126112	BEARING, tapered 1 1/4, cone	2
44	125892	SEAL, bearing, 1-1/4 shaft	1
45	126064	SHIM, caster	2
46	125890	NUT, 1 1/4-12 unf	1
47	126063	CAP, dust	1
55	100023	WASHER, flat	4
142	100133	WASHER, lock, 3/8	2
185	290159	LABEL, reflective	2
243	101714	NUT, lock	1
257	16P143	LABEL, release hydraulic drive	1
258	16P144	LABEL, caster wheel adjustment	1

* Replace with upgrade Kit 24Y509

Parts List - Series B

Ref.	Part	Description	Qty.
1	24L896	FRAME, painted, LL250	1
3	102393	NUT, lock	2
29	113743	SCREW, cap, hex hd	2
30	24L902	ADJUSTER, caster, weldment, LL250	1
31	126204	SCREW, cap, hex hd	1
34	24L897	CASTER, painted, LL250	1
35	16W284	WHEEL, foam filled (LL250 SPS, DC)	1
36	193658	SPACER, seal	2
37	113471	SCREW, cap, hex hd	1
39	112405	NUT, lock	1
40	125792	BALL, joint, rod end	2
41*	17H372	WASHER, thrust, 1-1/2 in. id	4
42*	17H377	BRACKET, steering, self centering	1
43	126112	BEARING, tapered 1 1/4, cone	2
44	125892	SEAL, bearing, 1-1/4 shaft	1
45	126064	SHIM, caster	2
46	125890	NUT, 1 1/4-12 unf	1
47	126063	CAP, dust	1
55	100023	WASHER, flat	4
135*	17H386	BRACKET	1
136*	260213	SCREW	2
137*	17H387	LEVER, upper	1
138*	17H388	LEVER, lower	1
143*	17H374	SPRING	2
142	100133	WASHER, lock, 3/8	2
185	290159	LABEL, reflective	2
243	101714	NUT, lock	1
257	16P143	LABEL, release hydraulic drive	1
258	16P144	LABEL, caster wheel adjustment	1

* Included in Kit 24Y509

Parts List

Ref.	Part	Description	Qty.	Ref.	Part	Description	Qty.
*9	111040	NUT, lock, insert, nylock, 5/16	4	172d	119647	SCREW, cap, socket, flthd	2
*11	24N170	BRACKET, mount, pointer complete	2	172f	15F750	KNOB, holder, gun	1
*18	24N171	ARM, pointer, complete	1	172g	15F209	STUD, pull, trigger	1
*32	17H445	INDICATOR, pointer	2	172h	24Y991	KIT, pivot	1
33	101566	NUT, lock	4	172j	16N788	STUD, cable, gun, circlip	1
49	24N350	BRACKET, gun arm	1	172k	119664	BEARING, sleeve	1
50▲	16P136	LABEL, injection read manual iso	2	172m	15F214	LEVER, actuator	1
*52	111145	KNOB, pronged	5	172n	24Y991	KIT, pivot	1
*86	114653	SCREW, cap, flange hd	4	173	248157	KIT, accessory, gun, flex	2
*87	17H438	WASHER, spring, wave	1	199†	24N492	KIT, repair, cable, gun, solenoid (includes 236)	2
*88	17H441	COLLAR, screw, set	1	226	245798	KIT, repair, hose	2
*89	114966	KNOB, pronged	2	227	188135	GUIDE, cable	2
*90	100527	WASHER, plain	4	228	17J408	ARM, extension, third gun	1
116	102040	NUT, lock, hex	3	229	17J424	EXTENSION, vertical gun arm	2
170	17J407	ARM, extension, bar, weldment	1	236	126111	RETAINER, circlip, external, 8mm	2
171	24Y645	KIT, clamp	2	*310	17H719	HOSE, pointer	2
172	24M638	BAR, gun holder, LLV 250SPS & 250DC	2				
172a	287569	KIT, repair, gun holder (includes 172f, 172k)	1				
172b	16M850	BRACKET, cable, gun,	1				
172c	17J145	ARM, holder, gun	1				

▲ Replacement warning labels may be ordered free of charge.

* Included in Pointer Accessory Kit 24N162

† Kit contains 1 cable and 2 retainer clips

Parts

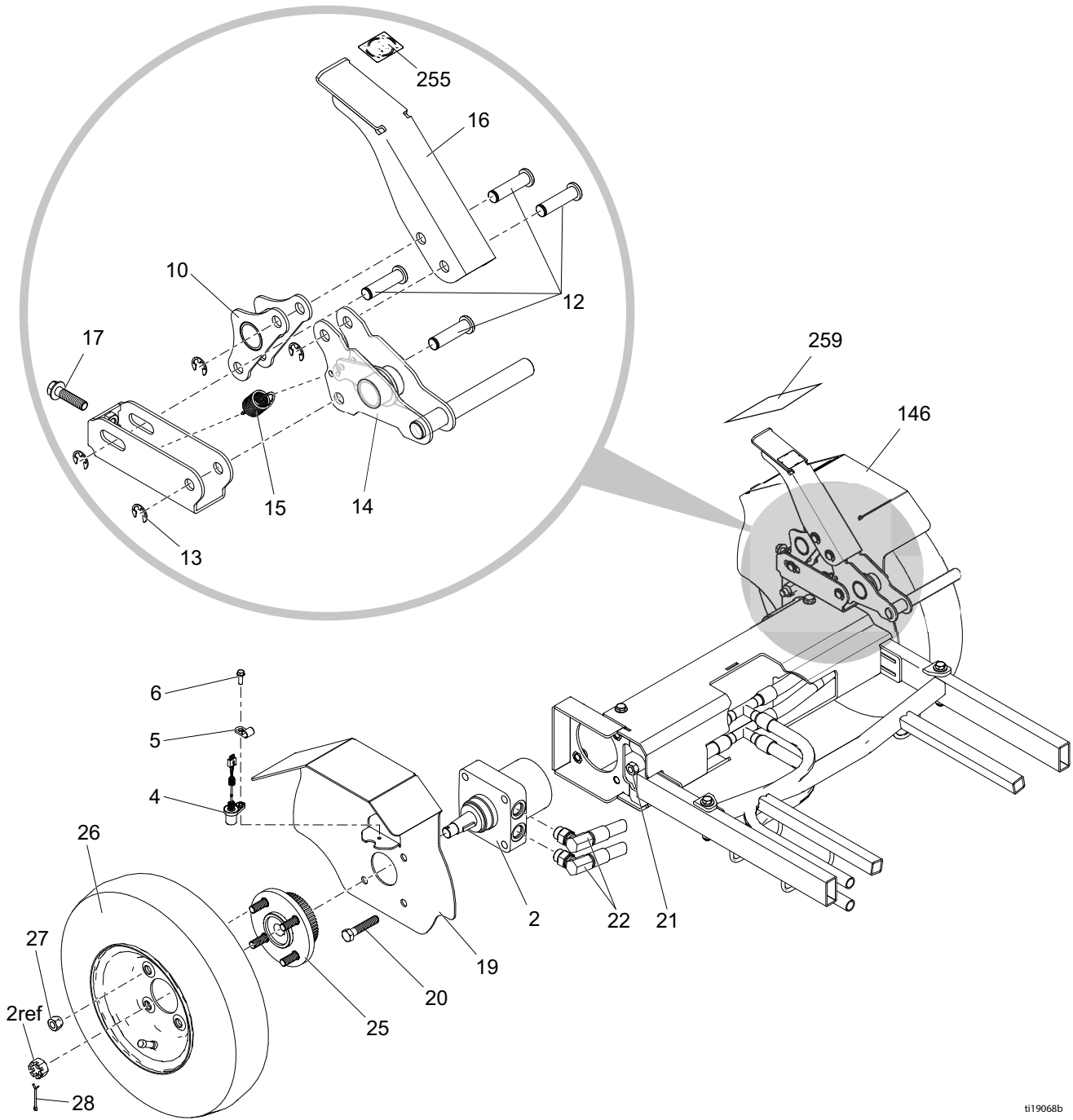

t119068b

Parts List

Ref.	Part	Description	Qty.	Ref.	Part	Description	Qty.
2	125929	MOTOR, wheel	2	20	114766	BOLT, cap hex head	8
4	15K357	SENSOR, distance	1	21	801020	NUT, lock, hex	8
5	108868	CLAMP, wire	1	22	18H276	KIT, hose	2
6	260212	SCREW, hex washer hd, thd form	1	25	24N508	KIT, repair, hub and gear assy	2
10	24M214	BRACKET, plate, pivot, brake, LL250	1	26	245340	KIT, repair, tire	2
12	16M656	PIN, brake	4	27	125481	NUT, wheel, 1/2-20	8
13	126073	RING, retaining, e ring, 1/2 dia	4	28	100104	PIN, cotter	2
14	24M215	BRACKET, lock, brake, LL250	1	146	16N394	FENDER, wheel, left, LL250, paint	1
15	15V264	SPRING, extension	1	255▲	16P141	LABEL, parking brake icon	1
16	16M743	PEDAL, brake, LL250	1	259▲	16P139	LABEL, multiple hazard iso	1
17	112785	SCREW, hex hd, flanged	1	▲ Replacement warning labels may be ordered free of charge.			
19	16M753	FENDER, wheel, right, LL250, paint	1				

Parts (Pump)

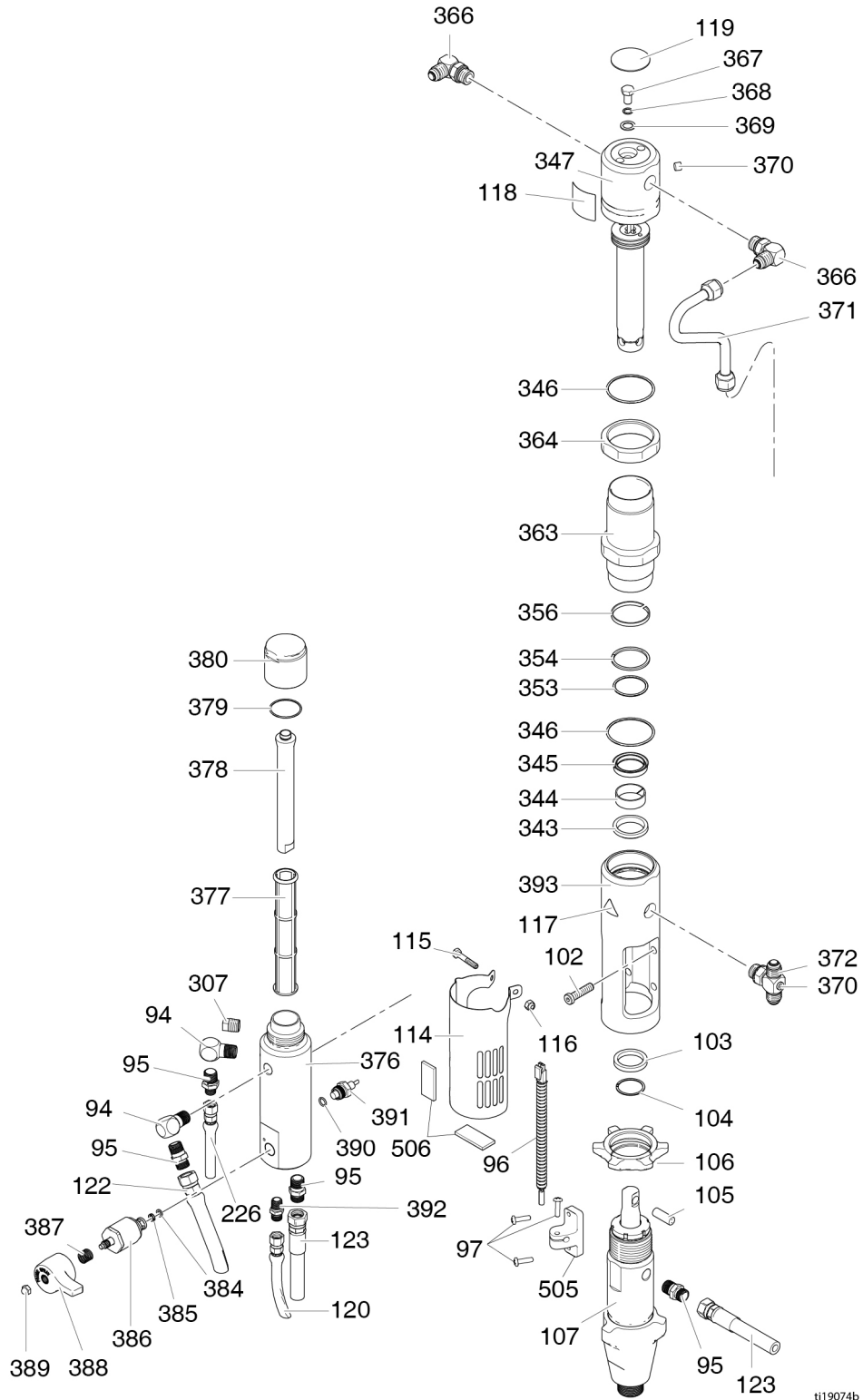

t119074b

Parts List (Pump)

Ref.	Part	Description	Qty.	Ref.	Part	Description	Qty.
94*	196179	ELBOW, street	2	364	15A726	NUT, jam	1
95*	196178	ADAPTER, nipple	4	366	117607	FITTING, elbow std thd	2
96†	2006321	SWITCH, reed w/connector	1	367	106276	SCREW, cap, hex head	1
97†	114528	SCREW, mach, phillips, pnhd	3	368	155685	PACKING, o-ring	1
102	107210	SCREW	4	369	178179	WASHER, sealing	1
103	287186	KIT, repair, magnet	1	370	100139	PLUG, pipe	2
104	116551	RING, retaining	1	371	15F519	TUBE, hydraulic, supply	1
105	197443	PIN, pump	1	372	119841	FITTING, tee, branch	1
106	193394	NUT, retaining	1	376*	15H561	MANIFOLD	1
107	277068	KIT, repair, pump 200HS (includes 95, 103, 104, 105)	1	377*	24V455	FILTER, 50 mesh, ultra	1
114	15F911	GUARD, pump rod	1	378*	15C766	TUBE, diffusion	1
115	100058	SCREW, cap, hex hd	1	379*	117285	PACKING, o-ring	1
116	102040	NUT, lock, hex	1	380*	287285	KIT, repair, filter cap (includes 378, 379)	1
117▲	15H108	LABEL, pinch point	1	384*	193710	SEAL, seat, valve	1
118	15B804	LABEL, Graco logo	1	385*	193709	SEAT, valve	1
119▲	15B063	LABEL	1	386*	245103	KIT, repair, drain valve (includes 384, 385, 387, 388, 389)	1
120	24V064	KIT, repair, suction hose	1	387*	114708	SPRING, compression	1
122	191239	HOSE, coupled, 3/8 in. x 11 ft	1	388*	15G563	HANDLE, valve	1
123	245797	KIT, repair, hose	1	389*	116424	NUT, cap	1
226	245798	HOSE, coupled, 1/4 in. x 7 ft	1	390*	111457	PACKING, o-ring	1
307*	15G331	PLUG, pipe	1	391*	24N516	KIT, repair, transducer (includes 390)	1
343	117739	WIPER, rod	1	392*	196181	FITTING, nipple	1
344	112342	NUT, jam	1	393	15A728	MANIFOLD, adapter	1
345	112561	PACKING, block	1	505†	2006622	BRACKET, reed	1
346	117283	PACKING, o-ring	2	506†	2006691	GASKET, foam	2
347	288754	KIT, repair, trip rod/piston (includes 118, 119)	1				
353	108014	PACKING, o-ring	1				
354	178226	SEAL, piston	1				
356	178207	BEARING, piston	1				
363	246176	SLEEVE, hydraulic, cylinder (includes 346)	1				

* Included in Filter Repair Kit 24N517

† Included in Magnet Repair Kit 287186

▲ Replacement warning labels may be ordered free of charge.

Wiring Diagram (Honda)

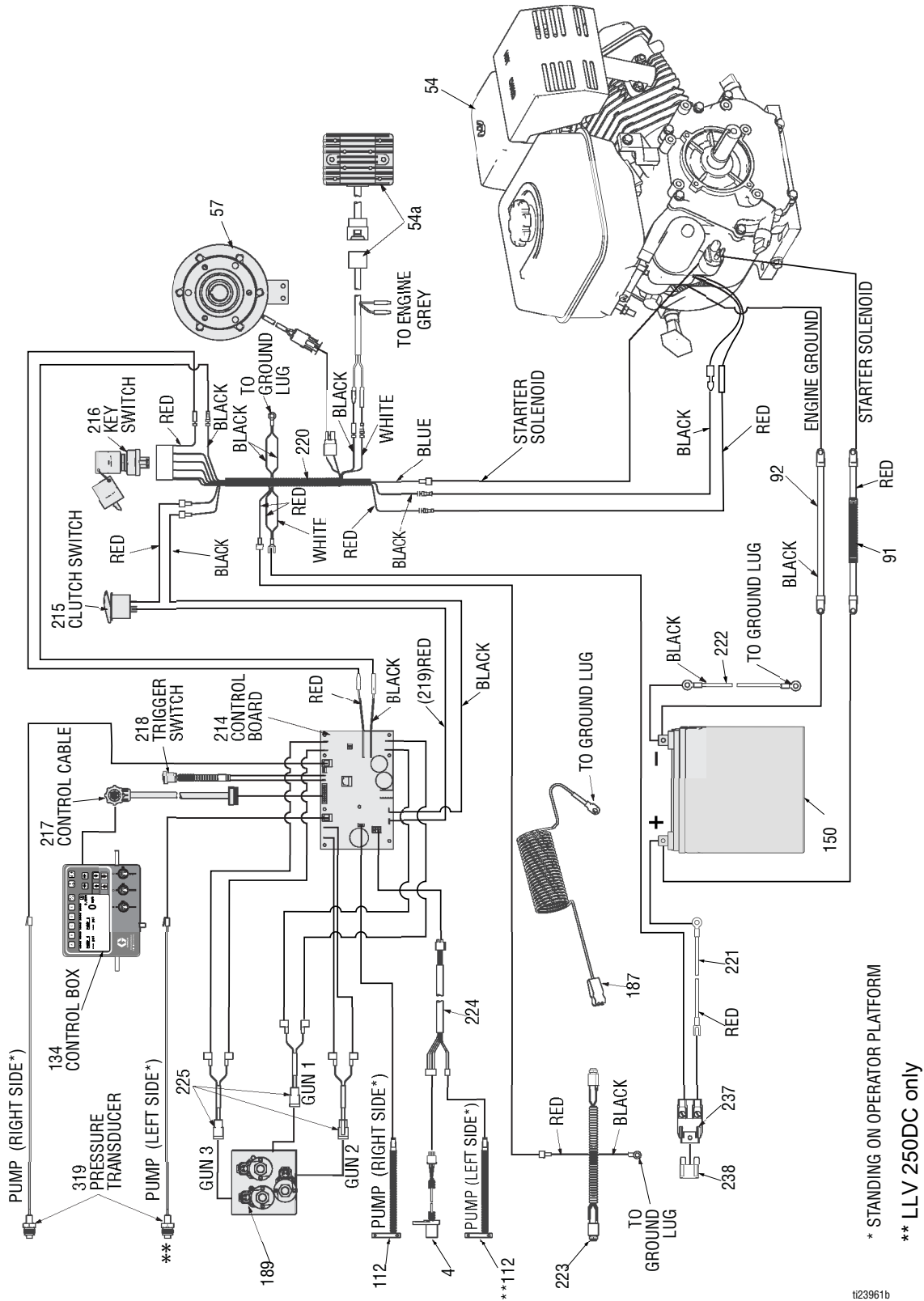

* STANDING ON OPERATOR PLATFORM

** LLV 250DC only

ti23961b

Wiring Parts List (Honda)

Ref.	Part	Description	Qty.	Ref.	Part	Description	Qty.
4	15K357	SENSOR, distance	1	189a	24N577	COIL, solenoid, hydraulic, manifold (included in 189)	2
54	24V562	KIT, repair, engine, GX390 (includes 54a)	1	214b	24V561	KIT, repair, control board	1
	25P364	KIT, repair, engine, GX390 (includes 54a) (China only)	1	215	17C063	SWITCH, rocker, SPST	1
54a	24N502	VOTLAGE REGULATOR	1	216	16X075	SWITCH, ignition	1
57	125877	CLUTCH, electric, LL250	1	217	24U233	CABLE, 18 conductor	1
91	16X079	CABLE, battery, positive		218	16N401	SWITCH, pushbutton	1
92	16X080	CABLE, battery, negative		219	17C064	WIRE, positive	1
112	119720	SWITCH, reed w/connector	2	220	16X078	HARNESS, wire, LL250DC	1
134	24U234	CONTROL, box, handlebar (includes 134a, 134b, 134c)	1	221	16N542	WIRE, positive battery	1
134a	24V565	KIT, display, repair	1	222	16N541	WIRE negative battery	1
134b	24V564	KIT, board, toggle switch	1	223	16N540	HARNESS, light connection	1
134c	24V566	KIT, switch, membrane	1	224	16N539	HARNESS, sensor adapter	1
150	115753	BATTERY, 33 AH, sealed	1	225	16N543	HARNESS, wire, hydraulic actuator	3
187	237686	WIRE, ground assembly w/ clamp	1	237	126095	HOLDER, fuse	1
189	24U862	MANIFOLD, hydraulic, three piston	1	238	126096	FUSE, 30A	1
				319	24N516	KIT, repair, transducer	1

Wiring Parts List (Vanguard)

Ref.	Part	Description	Qty.	Ref.	Part	Description	Qty.
4	15K357	SENSOR, distance	1	219	17C064	WIRE, positive	1
54	24V562V	KIT, repair, engine, Vanguard 14HP ES	1	220	16X078	HARNESS, wire, LL250DC	1
57	125877	CLUTCH, electric, LL250	1	221	16N542	WIRE, positive battery	1
91	16X079	CABLE, battery, positive		222	16N541	WIRE negative battery	1
92	16X080	CABLE, battery, negative		223	16N540	HARNESS, light connection	1
112	119720	SWITCH, reed w/connector	2	224	16N539	HARNESS, sensor adapter	1
134	24U234	CONTROL, box, handlebar (includes 134a, 134b, 134c)	1	225	16N543	HARNESS, wire, hydraulic actuator	3
134a	24V565	KIT, display, repair	1	237	126095	HOLDER, fuse	1
134b	24V564	KIT, board, toggle switch	1	238	126096	FUSE, 30A	1
134c	24V566	KIT, switch, membrane	1	319	24N516	KIT, repair, transducer	1
150	115753	BATTERY, 33 AH, sealed	1	474	19F898	ADAPTER, jumper	1
187	237686	WIRE, ground assembly w/ clamp	1	475	19F899	ADAPTER, jumper	1
189	24U862	MANIFOLD, hydraulic, three piston	1	478	19F902	ADAPTER, jumper	1
189a	24N577	COIL, solenoid, hydraulic, manifold (included in 189)	2	479	19F903	ADAPTER, jumper	1
214b	24V561	KIT, repair, control board	1	480	19F904	ADAPTER, jumper	1
215	17C063	SWITCH, rocker, SPST	1	482	19F993	CONNECTOR	1
216	16X075	SWITCH, ignition	1	483	19F994	BOX, gel	1
217	24U233	CABLE, 18 conductor	1	484	19F995	TAPE, mounting, foam	1
218	16N401	SWITCH, pushbutton	1	485	19F997	BRACKET, relay	1
				486	19F992	RELAY	1

Hydraulic Diagram

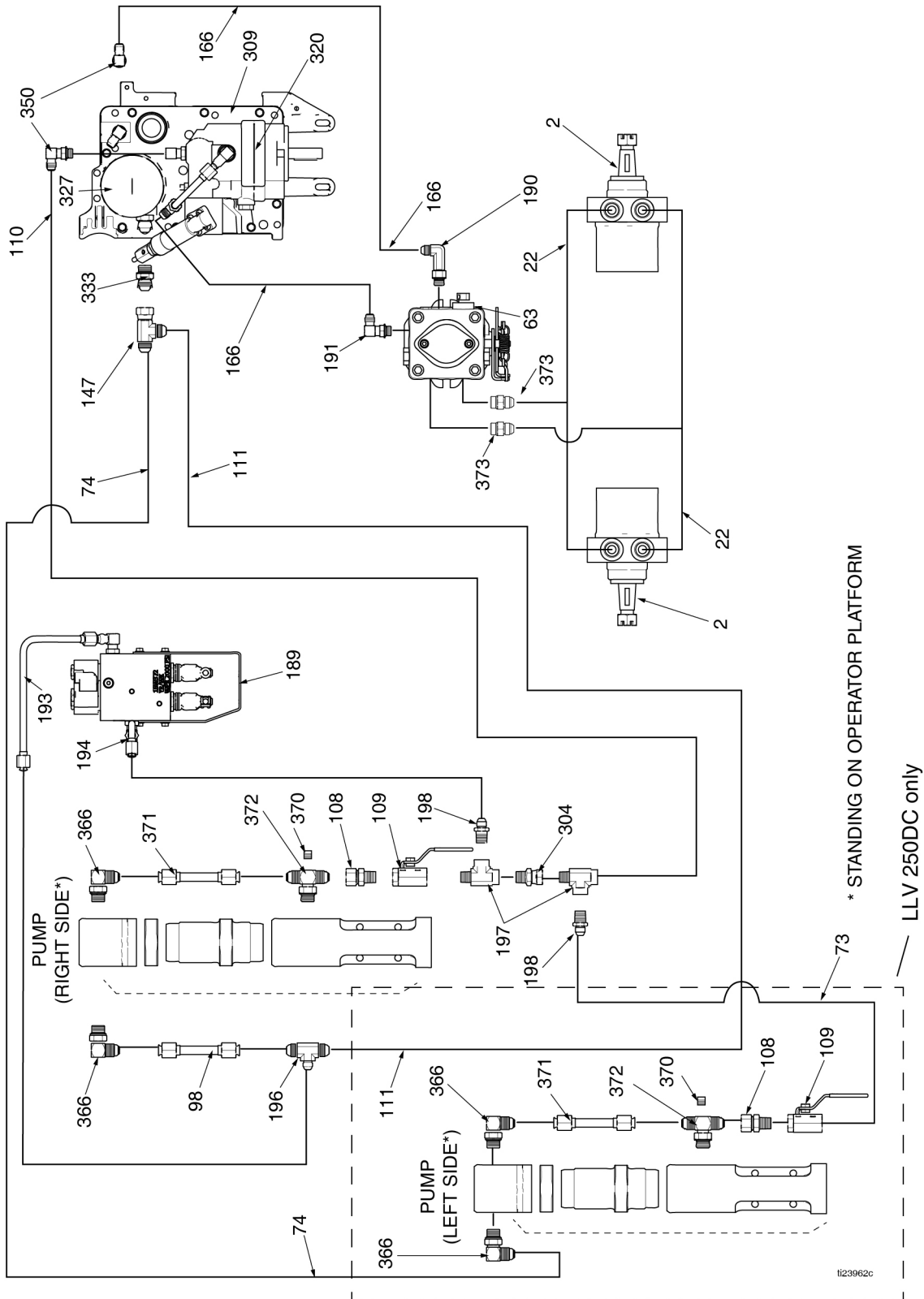

Hydraulic Parts List

Ref.	Part	Description	Qty.	Ref.	Part	Description	Qty.
2	125929	MOTOR, wheel	2	191	116829	FITTING, 90 degree, w/adjustable	1
22	18H276	KIT, hose	2	193	24M625	TUBE, supply, hydraulic	1
63	247930	KIT, repair, hydraulic pump	1	194	24M626	TUBE, supply, hydraulic	1
73	16X838	HOSE, hydraulic, supply 2nd pump	1	196	126082	FITTING, tee, #8 x #8 x #6 JIC	1
74	16X839	HOSE, hydraulic, return 2nd pump	1	197	126080	FITTING, tee, street	2
98	16P776	TUBE, supply, hydraulic	1	198	126081	FITTING, nipple, 3/8-18 x #6 JIC	2
108	117328	FITTING, nipple, straight	2	304	155665	UNION, adapter	1
109	117441	VALVE, ball	2	309	16M160	COVER, reservoir, LL250, painted	1
110	287175	KIT, repair, hose, hydraulic supply	1	320	16X083	KIT, repair, pump, 250SPS	1
111	287176	KIT, repair, hose, hydraulic return	1	327	246173	KIT, repair, oil filter	1
147	124770	FITTING, tee, 1/2 JIC, swivel	1	333	120184	FITTING, hydraulic	1
166	16M276	HOSE, coupled, feed line, LL250	2	350	116829	FITTING, 90 degree, w/adjustable o-ring	2
189	24U862	MANIFOLD, hydraulic, three piston (includes three 189a, 189b and 189c)	1	366	117607	FITTING, elbow std thd	4
189a	24N577	COIL, solenoid, hydraulic, manifold	1	370	100139	PLUG, pipe	2
189b	24N490	KIT, repair, solenoid (includes 189a)	1	371	15F519	TUBE, hydraulic, supply	2
189c	24V560	KIT, repair, actuator piston	1	372	119841	FITTING, tee, branch	2
190	124941	FITTING, long elbow, hydraulic	1	373*	2004330	FITTING, adapter, JIC to orb	2

* Included in Kit 18H276.

California Proposition 65

CALIFORNIA RESIDENTS

 **WARNING:** Cancer and reproductive harm – www.P65warnings.ca.gov.

Graco Standard Warranty

Graco warrants all equipment referenced in this document which is manufactured by Graco and bearing its name to be free from defects in material and workmanship on the date of sale to the original purchaser for use. With the exception of any special, extended, or limited warranty published by Graco, Graco will, for a period of twelve months from the date of sale, repair or replace any part of the equipment determined by Graco to be defective. This warranty applies only when the equipment is installed, operated and maintained in accordance with Graco's written recommendations.

This warranty does not cover, and Graco shall not be liable for general wear and tear, or any malfunction, damage or wear caused by faulty installation, misapplication, abrasion, corrosion, inadequate or improper maintenance, negligence, accident, tampering, or substitution of non-Graco component parts. Nor shall Graco be liable for malfunction, damage or wear caused by the incompatibility of Graco equipment with structures, accessories, equipment or materials not supplied by Graco, or the improper design, manufacture, installation, operation or maintenance of structures, accessories, equipment or materials not supplied by Graco.

This warranty is conditioned upon the prepaid return of the equipment claimed to be defective to an authorized Graco distributor for verification of the claimed defect. If the claimed defect is verified, Graco will repair or replace free of charge any defective parts. The equipment will be returned to the original purchaser transportation prepaid. If inspection of the equipment does not disclose any defect in material or workmanship, repairs will be made at a reasonable charge, which charges may include the costs of parts, labor, and transportation.

THIS WARRANTY IS EXCLUSIVE, AND IS IN LIEU OF ANY OTHER WARRANTIES, EXPRESS OR IMPLIED, INCLUDING BUT NOT LIMITED TO WARRANTY OF MERCHANTABILITY OR WARRANTY OF FITNESS FOR A PARTICULAR PURPOSE.

Graco's sole obligation and buyer's sole remedy for any breach of warranty shall be as set forth above. The buyer agrees that no other remedy (including, but not limited to, incidental or consequential damages for lost profits, lost sales, injury to person or property, or any other incidental or consequential loss) shall be available. Any action for breach of warranty must be brought within two (2) years of the date of sale.

GRACO MAKES NO WARRANTY, AND DISCLAIMS ALL IMPLIED WARRANTIES OF MERCHANTABILITY AND FITNESS FOR A PARTICULAR PURPOSE, IN CONNECTION WITH ACCESSORIES, EQUIPMENT, MATERIALS OR COMPONENTS SOLD BUT NOT MANUFACTURED BY GRACO. These items sold, but not manufactured by Graco (such as electric motors, switches, hose, etc.), are subject to the warranty, if any, of their manufacturer. Graco will provide purchaser with reasonable assistance in making any claim for breach of these warranties.

In no event will Graco be liable for indirect, incidental, special or consequential damages resulting from Graco supplying equipment hereunder, or the furnishing, performance, or use of any products or other goods sold hereto, whether due to a breach of contract, breach of warranty, the negligence of Graco, or otherwise.

FOR GRACO CANADA CUSTOMERS

The Parties acknowledge that they have required that the present document, as well as all documents, notices and legal proceedings entered into, given or instituted pursuant hereto or relating directly or indirectly hereto, be drawn up in English. Les parties reconnaissent avoir convenu que la rédaction du présente document sera en Anglais, ainsi que tous documents, avis et procédures judiciaires exécutés, donnés ou intentés, à la suite de ou en rapport, directement ou indirectement, avec les procédures concernées.

Graco Information

For the latest information about Graco products, visit www.graco.com.

For patent information, see www.graco.com/patents.

TO PLACE AN ORDER, contact your Graco distributor or call 1-800-690-2894 to identify the nearest distributor.

*All written and visual data contained in this document reflects the latest product information available at the time of publication.
Graco reserves the right to make changes at any time without notice.*

Original instructions. This manual contains English. MM 3A3394

Graco Headquarters: Minneapolis

International Offices: Belgium, China, Japan, Korea

GRACO INC. AND SUBSIDIARIES • P.O. BOX 1441 • MINNEAPOLIS MN 55440-1441 • USA
Copyright 2016, Graco Inc. All Graco manufacturing locations are registered to ISO 9001.

www.graco.com

Revision L, August 2024