

LineLazer™ V 200HS / 200DC Airless Line Stripers

Standard Series and High Production (HP) Series

3A3390H

EN

For the application of line striping materials.
For professional use only.
For outdoor use only.
Not for use in explosive atmospheres or hazardous locations.

Maximum Operating Pressure: 3300 psi (22.8 MPa, 228 bar)



Important Safety Instructions

Read all warnings and instructions in this manual and in related manuals.
 Be familiar with the controls and the proper usage of the equipment.
 Save these instructions.

Related Manuals:			
3A3426	Operation	309277	Pump
311254	Gun	3A3428	Auto-Layout Applications Methods
332230	Bead System	3B0122	Gallon Counter Replacement

LineLazer V 200HS
Standard Series

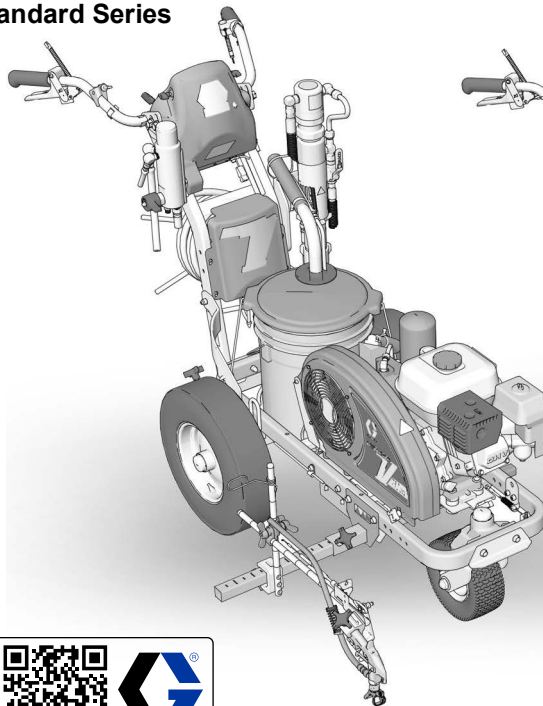

LineLazer V 200DC

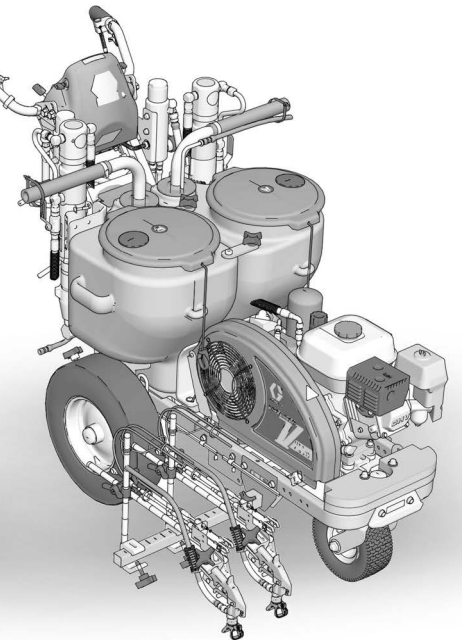



SERVICE
to every customer, every time

??



??





www.graco.com/techsupport

Use only genuine Graco replacement parts.
 The use of non-Graco replacement parts may void warranty.



Contents

Tip Selection	4
LineLazer V 200HS Parts (Standard & HP Series)	5
LineLazer V 200DC Parts (Standard & HP Series)	6
Notes	7
Parts Drawing - LineLazer V 200HS	8
Parts List - LineLazer V 200HS	9
Parts Drawing - LineLazer V 200DC	10
Parts List - LineLazer V 200DC	11
Parts Drawing - LineLazer V 200HS / 200DC	12
Parts List - LineLazer V 200HS / 200DC	13
Gun Holder and Arm	13
Gun Trigger	13
Parts Drawing - LineLazer V 200HS / 200DC	14
Parts List - LineLazer V 200HS / 200DC	15
Handle/Controls	15
Filter - 200HS	15
Parts Drawing - LineLazer V 200DC	16
Parts List - LineLazer V 200DC	17
Filters A & B	17
Parts Drawing - LineLazer V 200HS	18
Parts List - LineLazer V 200HS	19
Parts Drawing - LineLazer V 200DC	20
Parts List - LineLazer V 200DC	21
Parts Drawing - LineLazer V 200HS / 200DC	22
Parts List - LineLazer V 200HS / 200DC	23
Parts Drawing - LineLazer V 200HS / 200DC	24
Parts List - LineLazer V 200HS / 200DC	25
Main Control Board Replacement	26
Display Assembly Replacement	27
Wiring Diagram 200HS (Standard Series)	28
Wiring Diagram 200DC (Standard Series)	29
Wiring Diagram 200HS (HP Auto Series/HP Reflective Series)	30
Wiring Diagram 200DC (HP Auto Series/HP Reflective Series)	31
Technical Specifications	32
Graco Standard Warranty	38
Graco Information	38

Manual	Language
3A3390	English
3A3813	French
3A3814	Spanish
3A3821	Dutch
3A3824	German
3A3827	Italian
3A3705	Russian
3A3831	Polish
3A3815	Chinese
3A3816	Korean
3A3817	Japanese

Models

LineLazer V 200HS & 200DC										
	Model:	Standard 1 Manual Gun	Standard 2 Manual Guns	HP Auto 1 Auto Gun	HP Auto 1 Manual Gun 1 Auto Gun	HP Auto 2 Auto Guns	HP Reflective 1 Manual Gun 1 PBS Tank	HP Reflective 1 Auto Gun 1 PBS Tank	HP Reflective 2 Auto Guns 1 PBS Tank	HP Reflective 2 Manual Guns 1 PBS Tank
200HS	17H459	✓								
	25P342	✓								
	17H461		✓							
	25P343		✓							
	17K582			✓						
	17H462			✓ with laser						
	17K637				✓					
	17H463				✓ with laser					
	17K583					✓				
	25P344					✓				
	17H464					✓ with laser				
	25P345					✓ with laser				
	17H460						✓			
	17J964							✓		
	17K585								✓	
17H465								✓ with laser		
200DC	17Y269					✓ with laser				
	25P350					✓ with laser				
	17Y270							✓ with laser		
	25P348							✓ with laser		
	17Y231		✓							
	25P346		✓							
	17Y232					✓				
	25P349					✓				
	17Y233								✓	
	25P347								✓	
	17Y648									✓

* All auto guns can be actuated manually.

Tip Selection

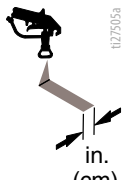
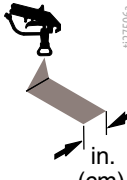
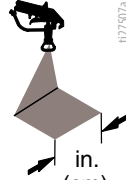
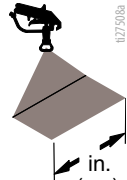
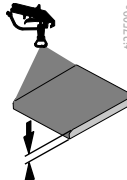
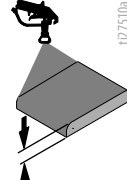
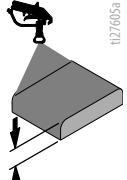
 127606a	 127505a in. (cm)	 127506a in. (cm)	 127507a in. (cm)	 127508a in. (cm)	 127509a	 127510a	 127605a
LL5213*	2 (5)				✓		
LL5215*	2 (5)					✓	
LL5217		4 (10)				✓	
LL5219		4 (10)					✓
LL5315*		4 (10)			✓		
LL5317		4 (10)			✓		
LL5319		4 (10)				✓	
LL5321		4 (10)				✓	
LL5323		4 (10)				✓	
LL5325		4 (10)					✓
LL5327		4 (10)					✓
LL5329		4 (10)					✓
LL5331		4 (10)					✓
LL5333		4 (10)					✓
LL5335		4 (10)					✓
LL5355		4 (10)					✓
LL5417			6 (15)		✓		
LL5419			6 (15)		✓		
LL5421			6 (15)		✓		
LL5423			6 (15)			✓	
LL5425			6 (15)			✓	
LL5427			6 (15)			✓	
LL5429			6 (15)			✓	
LL5431			6 (15)				✓
LL5435			6 (15)				✓
LL5621				12 (30)	✓		
LL5623				12 (30)	✓		
LL5625				12 (30)	✓		
LL5627				12 (30)	✓		
LL5629				12 (30)	✓		
LL5631				12 (30)		✓	
LL5635				12 (30)		✓	
LL5639				12 (30)			✓

* Use 100 mesh filter to reduce tip clogs.

LineLazer V 200HS Parts (Standard & HP Series)

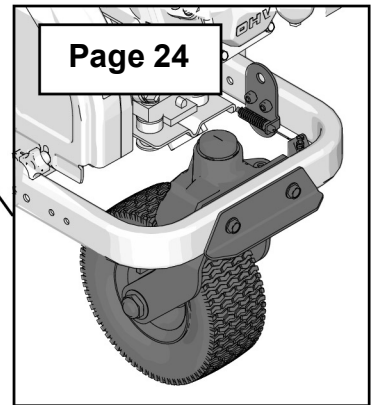
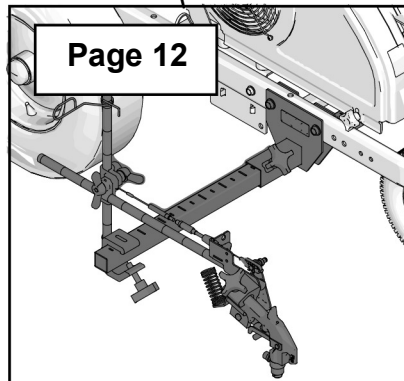
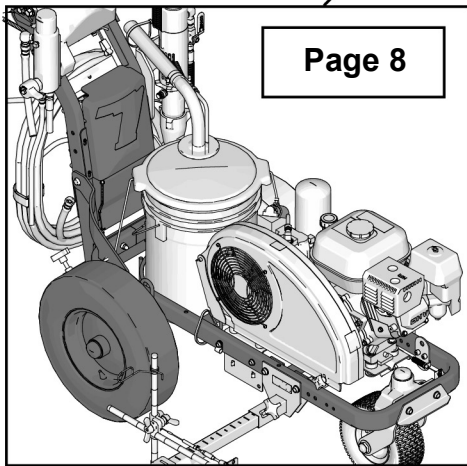
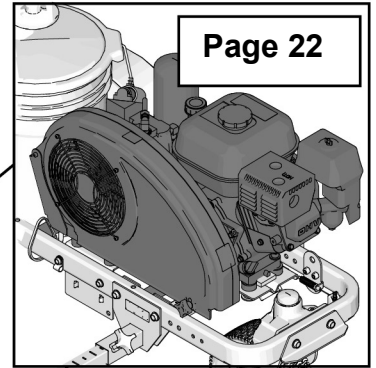
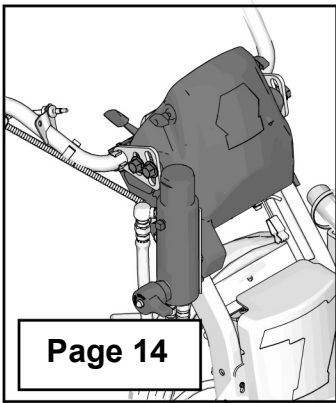
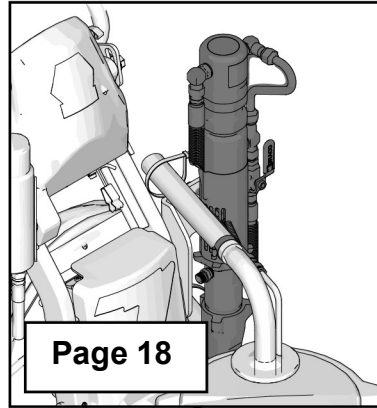
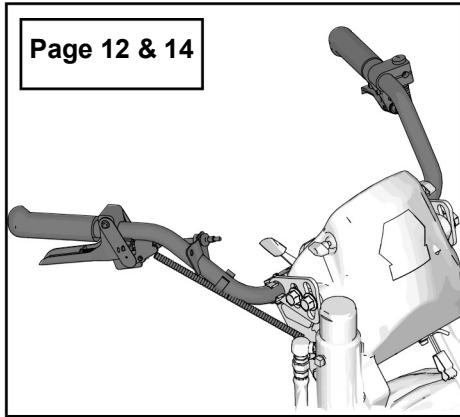



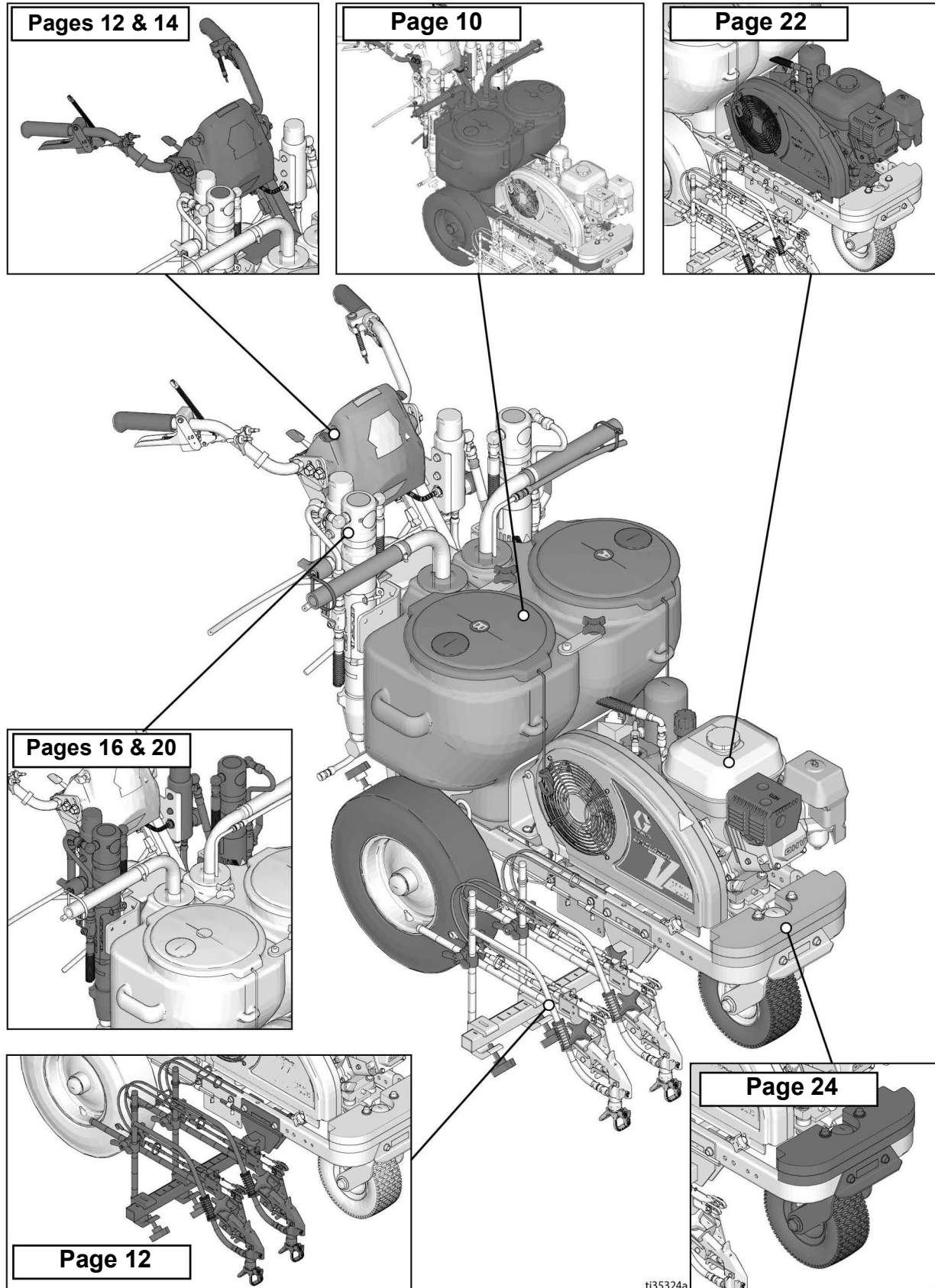

ti28065a

LineLazer V 200DC Parts (Standard & HP Series)



Parts Drawing - LineLazer V 200HS

-  Torque to 45-55 ft-lbs
(61.0-74.5 N·m)
-  Torque to 17-23 ft-lbs
(23.0-31.1 N·m)
-  Rear tire pressure 58-62 psi
(3.9-4.2 bar)
-  Torque to 190-210 in-lbs
(21.4-23.7 N·m)
-  Torque to 130-150 in-lbs
(14.6-16.9 N·m)

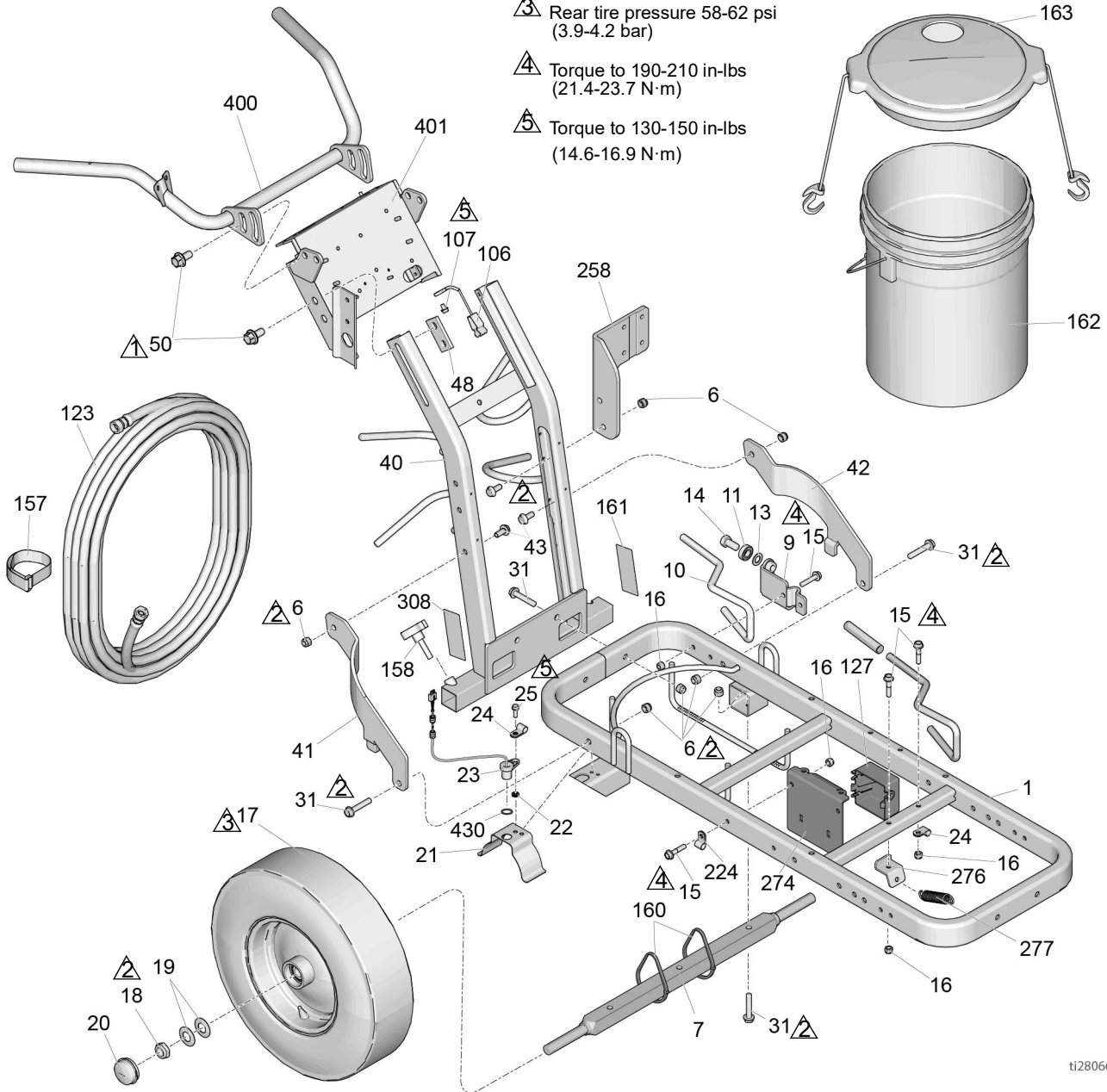





ti28066a

Parts List - LineLazer V 200HS

Ref	Part	Description	Qty	Ref	Part	Description	Qty
1	287623	FRAME, linestriper, painted	1	48	17J125	BRACKET, slide	2
6	101566	NUT, lock	12	50	17J136	SCREW, hex, flange head	8
7	193405	AXLE	1	106	237686	WIRE, ground	1
9	198891	BRACKET	1	107	107257	SCREW, thread forming, hex hd	1
10	198930	ROD, brake	1	123	124884	HOSE, coupled, 3/8"x22'	1
11	198931	BEARING	1	127	15F369	BOX	1
13	195134	SPACER	1	157	114271	STRAP, retaining	1
14	113961	SCREW, cap, hex hd	1	158	108471	KNOB, pronged	1
15	112960	SCREW, flange, hex	5	160	404989	STRAP, tie	5
16	111040	NUT, lock, insert, nylock, 5/16	5	161▲	17K394	LABEL, warning fire & skin	1
17	111020	WHEEL, pneumatic w/o sensor ring	1	162	115077	PAIL, plastic	1
	255162	WHEEL, pneumatic w/ sensor ring	1	163	24U241	KIT, pail, cover	1
18	112405	NUT, lock	2	224	17H721	CLAMP, wire	1
19	112825	WASHER	4	258	17H681	BRACKET, mount, pump, hydraulic	1
20	114648	CAP, dust	2	274	17J549	BRACKET, reservoir	1
21	15J088	SHIELD, distance sensor	1	276	15F441	BRACKET, frame	1
22	15K452	SPACER, round	1	277	119696	SPRING, extension	1
23	15K357	SENSOR, distance	1	308▲	17K392	LABEL, safety, warning	1
24	108868	CLAMP, wire	2	400	24Y641	BAR, handle	1
25	260212	SCREW, hex washer hd, thd form	2	401	24Y642	PLATE, control	1
31	114982	SCREW, cap, flange hd	6	430	155500	PACKING, o-ring	1
40	24Y665	FRAME, handle upright, painted	1				
41	15F576	BRACE, right, painted	1				
42	15F577	BRACE, left, painted	1				
43	128977	SCREW, cap button hd	4				

▲ Replacement safety labels, tags, and cards are available at no cost.

Parts Drawing - LineLazer V 200DC

-  Torque to 45-55 ft-lbs
(61.0-74.5 N·m)
-  Torque to 17-23 ft-lbs
(23.0-31.1 N·m)
-  Rear tire pressure 58-62 psi
(3.9-4.2 bar)
-  Torque to 190-210 in-lbs
(21.4-23.7 N·m)
-  Torque to 130-150 in-lbs
(14.6-16.9 N·m)

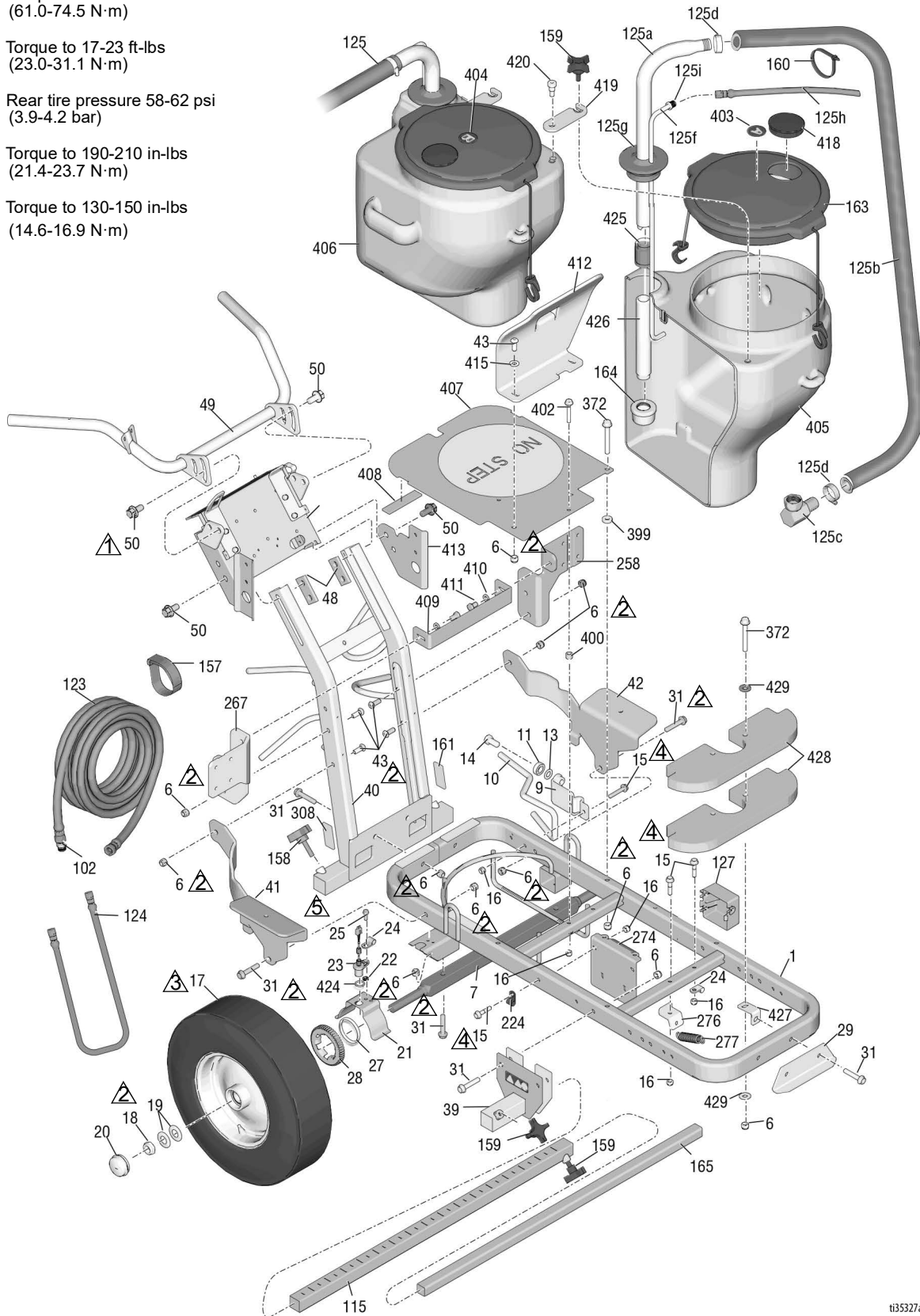

t135327a

Parts List - LineLazer V 200DC

Ref	Part	Description	Qty	Ref	Part	Description	Qty
1	287623	FRAME, linstriper, painted	1	157	114271	STRAP, retaining	2
6	101566	NUT, lock	12	158	108471	KNOB, pronged	1
7	193405	AXLE	1	159*	111145	KNOB, pronged	4
9	198891	BRACKET	1	160	404989	STRAP, tie	9
10	198930	ROD, brake	1	161▲	17K394	LABEL, warning fire & skin	1
11	198931	BEARING	1	163*	24U241	KIT, pail, cover	1
13	195134	SPACER, ball, guide	1	164	187147	STRAINER, inlet	2
14	113961	SCREW, cap, hex hd	1	165	17J408	ARM, extension, third gun	1
15	112960	SCREW, flange, hex	5	224	17H721	CLAMP, wire, 5/8 dia.	2
16	111040	NUT, lock, insert, nylock, 5/16	5	258	17Y049	BRACKET, mount, pump, hydraulic, left	1
17	111020	WHEEL, pneumatic w/o sensor ring	1	267	17Y047	BRACKET, mount, pump, hydraulic, right	
	255162	WHEEL, pneumatic w/ sensor ring	2	274	17J549	BRACKET, reservoir	1
18	112405	NUT, lock	2	276	15F441	BRACKET, frame	1
19	112825	WASHER, Belleville	4	277	119696	SPRING, extension	1
20	114648	CAP, dust	2	308▲	17K392	LABEL, safety, warning	1
21	15J088	SHIELD, distance sensor	1	372	125626	SCREW, hex hd, flanged	3
22	15K452	SPACER, round	1	399	16A719	WASHER, flat	1
23	15K357	SENSOR, distance	1	400	197449	SPACER	1
24	108868	CLAMP, wire	2	402	114653	SCREW, cap, flange head	1
25	260212	SCREW, hex washer hd, thd form	2	403*	17Y328	LABEL, identification, letter "A"	1
27	15K700	RING, sensor gear	1	404*	17Y329	LABEL, identification, letter "B"	1
28	15J575	GEAR, signal	1	405*	17Y026	RESERVOIR, 11 gallon, left	1
29	240991	BRACKET, caster, front	1	406*	17Y025	RESERVOIR, 11 gallon, right	1
31	114982	SCREW, cap, flange hd	6	407	17Y054	PLATE, bucket holder	1
39	17H528	BRACKET, gun arm	1	408	17P800	BUMPER	4
40	24Y665	FRAME, handle upright, painted	1	409	17Y050	BRACKET, reservoir, support	1
41	17Y059	BRACE, right, painted	1	410	100133	WASHER, lock, 3/8	2
42	17Y058	BRACE, left, painted	1	411	100575	SCREW, cap, hex hd	2
43	128977	SCREW, cap button hd	4	412	17Y055	SUPPORT, reservoir, front	1
48	17J125	BRACKET, slide	2	413	17Y104	BRACKET, manifold, filter	1
49	24Y641	BAR, handle	1	415	100731	WASHER	2
50	17J136	SCREW, hex, flange head	8	418*	127375	PLUG, 3.0" hole	2
102	196176	ADAPTER, nipple	2	419*	16X081	BRACKET, dual tank retaining	2
115	17J407	ARM, extension, bar, weldment	1	420*	126108	SCREW, shoulder, socket head	2
123	191239	HOSE, cpld, 3/8" x 11'10"	2	424	155500	PACKING, o-ring	1
124	245227	HOSE, cpld, 1/4" x 7'	2	425	114967	COUPLING, pipe, 1"	2
125	24V064	HOSE, suction/drain (includes 125a-125i)	2	426	189674	TUBE, intake	2
125a	15F149	TUBE, suction	2	427	17Y903	BRACKET, weight	2
125b	194306	HOSE, fluid	2	428	17Y900	BLOCK, weight, painted	2
125c	198119	FITTING, elbow, barbed	2	429	100132	WASHER, flat	4
125d	101818	CLAMP, hose	2				
125f	16X071	TUBE, drain line	2				
125g	278722	GASKET, pail	2				
125h	248008	HOSE, coupled, 1/4"x44"	2				
125i	196180	BUSHING	2				
127	15F369	BOX	1				

* Available in Dual Hopper Kit 25N622.

▲ Replacement safety labels, tags, and cards are available at no cost.

Parts Drawing - LineLazer V 200HS / 200DC

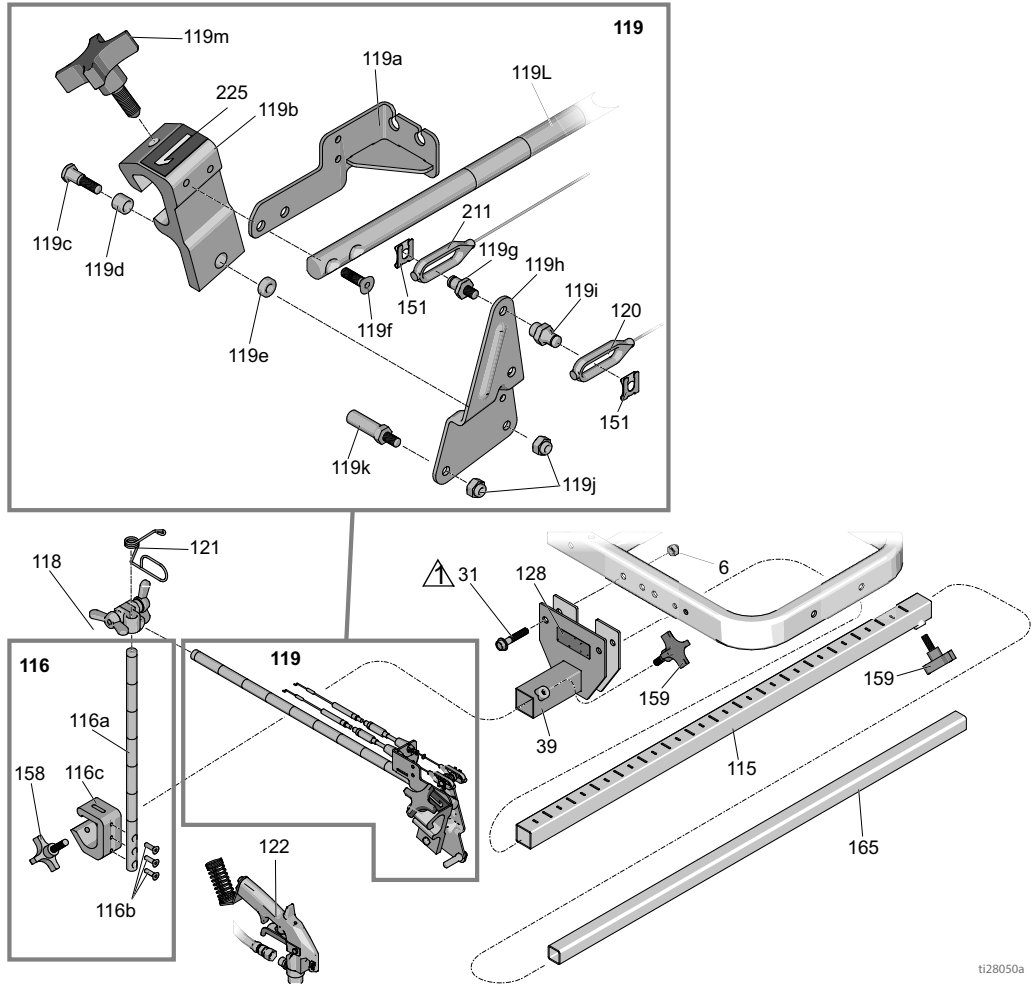

 Torque to 17-23 ft-lbs
(23.0-31.1 N·m)

 Torque to 18-22 in-lbs
(2.0-2.4 N·m)

ti28050a

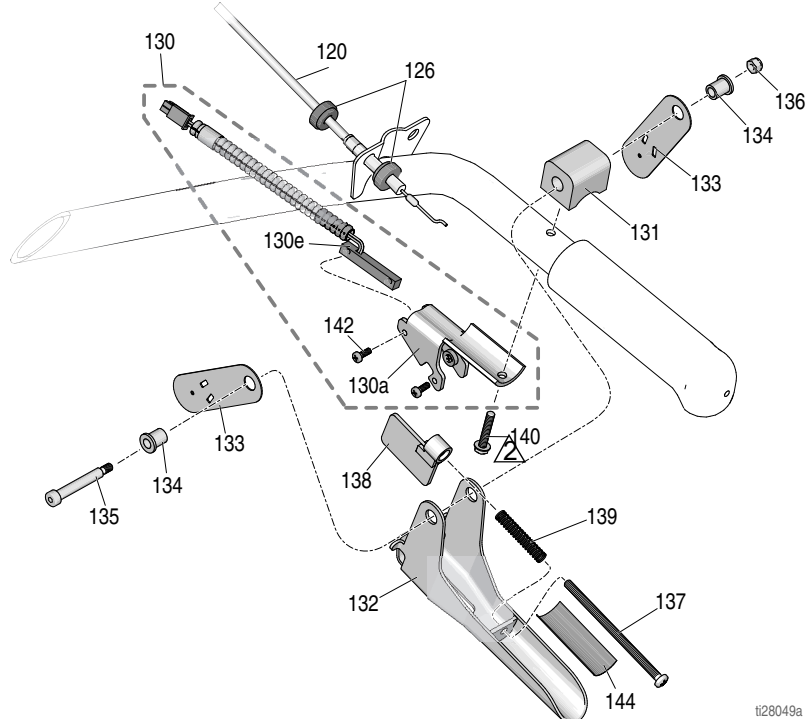

ti28049a

Parts List - LineLazer V 200HS / 200DC

Gun Holder and Arm

Ref.	Part	Description	Qty.
6	101566	NUT, lock	2
31	114982	SCREW, cap, flange hd	2
39	17H528	BRACKET, gun arm	1
115	17J407	ARM, extension, bar	1
116	17J424	BAR, height adjustment, assy	1
116a	17J139	BAR, gun, height, adjustment	1
116b	113428	SCREW, mach, hex, hd	3
116c	17J153	BRACKET, gun holder	1
118	24Y645	KIT, clamp, double wing nut	1
119	25A529	ARM, gun holder, linelazer (includes 151)	1
119a	24Y919	BRACKET, cable	1
119b*	15F216	HOLDER, gun	1
119c	17J575	FASTENER, special	1
119d*	119664	BEARING, sleeve	1
119e	17J576	SPACER, special	1
119f	119647	SCREW, cap, socket	2
119g	17H673	STUD, cable, gun	1
119h	15F214	LEVER, actuator	1
119i	17H674	ADAPTER, cable, gun	1
119j	102040	NUT, lock hex	2
119k	15F209	STUD, pull, trigger	1
119l	17J145	ARM, holder, gun	1
119m*	15F750	KNOB, holder, gun	1
120	25A488	CABLE, gun, manual (includes 126, 151)	1
121	188135	GUIDE, cable	1
122	248157	GUN, flex, basic	1
128▲	16P136	LABEL, safety, warning, ISO	1
151	126111	RETAINER, circlip, external, 8mm	2
158	108471	KNOB, pronged	1
159	111145	KNOB, pronged	2
165	17J408	ARM, extension, third gun	1
211	25A487	CABLE, gun, automatic (includes 151, 212, 213)	1
225	17C043	LABEL, number "1"	1
	17C046	LABEL, number "2"	1

* Included in Gun Holder Repair Kit 287569

▲ Replacement safety labels, tags, and cards are available at no cost.

Gun Trigger

Ref.	Part	Description	Qty.
120	25A488	CABLE, gun, manual (includes 126, 151)	1
126	15F624	NUT, cable, gun (knurled)	2
130	25A636	BRACKET, trigger w switch	1
130a	276907	BRACKET, magnet	1
130e	17J237	SWITCH, reed	1
131	198896	BLOCK, mounting	1
132	245676	HANDLE	1
133	198895	PLATE, lever, pivot	2
134	111017	BEARING, flange	2
135	116941	SCREW, shoulder, skt hd	1
136	116969	NUT, lock	1
137	112381	SCREW, mach, pan head	1
138	117268	BRACKET, interrupter	1
139	117269	SPRING	1
140	128803	SCREW, thd forming, hex washer	1
142	117317	SCREW, plastite, pan head	2
144	17K587	LABEL, notice, adjustment	1

Parts Drawing - LineLazer V 200HS / 200DC

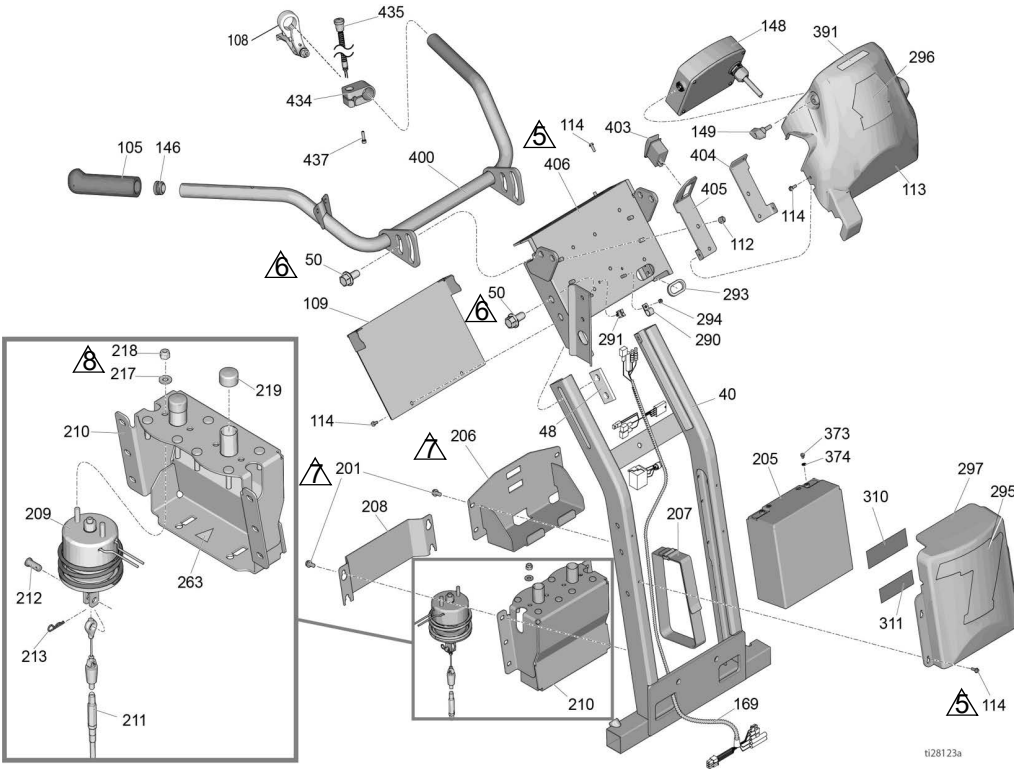

NOTICE	
<p>Do not allow the solenoid wires to make a sharp bend as shown. Doing so may lead to wire breakage. Place an approximate 0.75" radius bend in the wires exiting the solenoid.</p>	

- Torque to 35-45 ft-lbs (47.4-61.0 N·m)
- Torque to 190-210 in-lbs (21.4-23.7 N·m)
- Torque to 365-385 in-lbs (41.2-43.4 N·m)
- Torque to 25-30 in-lbs (2.8-3.3 N·m)
- Torque to 18-22 in-lbs (2.0-2.4 N·m)
- Torque to 45-55 ft-lbs (61.0-74.5 N·m)
- Torque to 130-150 in-lbs (14.6-16.9 N·m)
- Torque to 65-75 in-lbs (7.3-8.4 N·m)

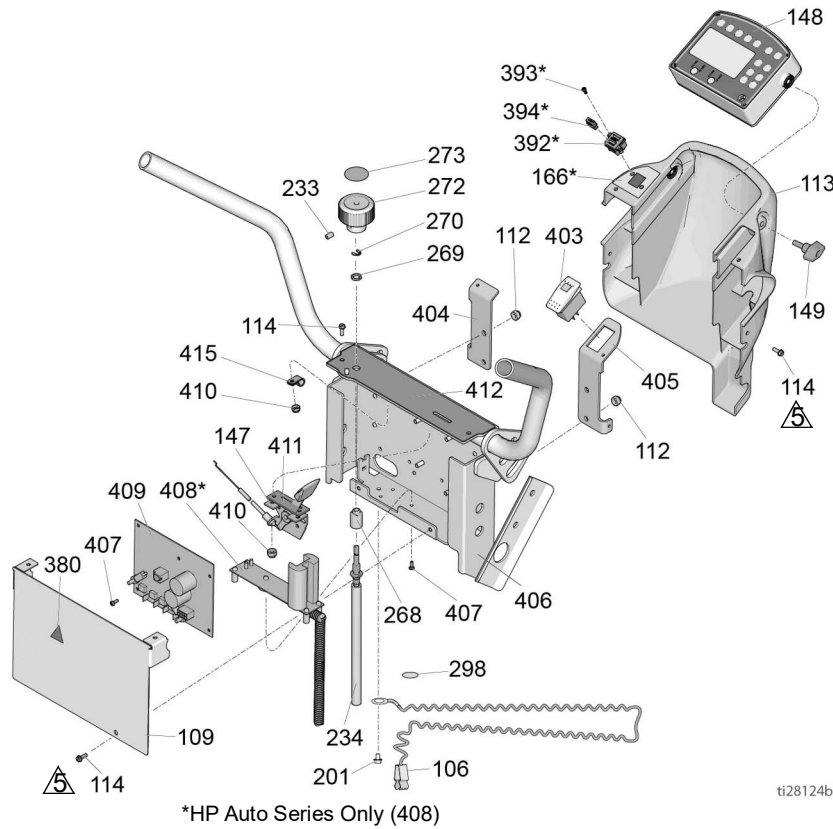

ti28124b

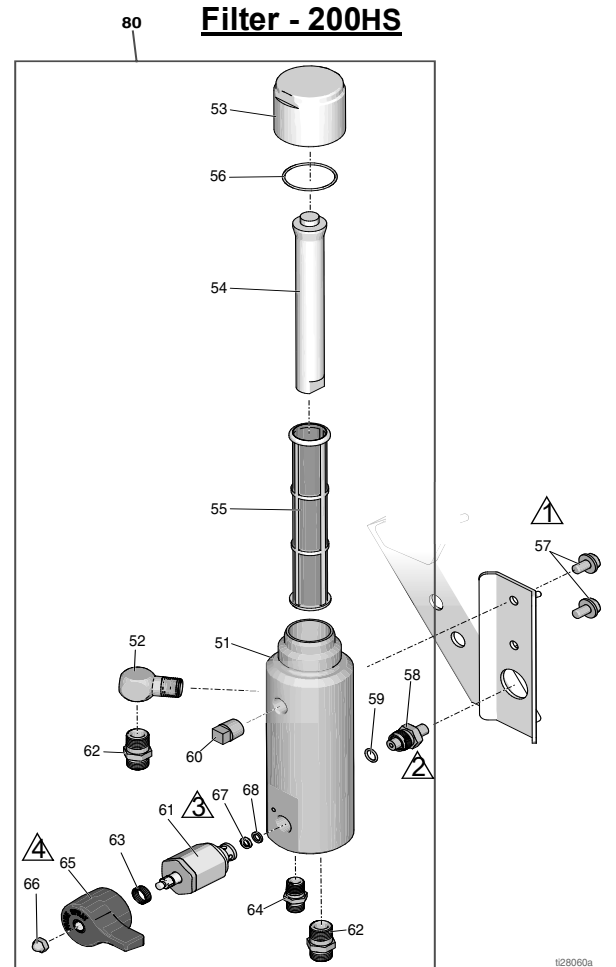

ti28000a

Parts List - LineLazer V 200HS / 200DC

Handle/Controls





Ref	Part	Description	Qty	Ref	Part	Description	Qty
				380	189930	LABEL, caution	1
				391	17P925	LABEL, A+ Service, QR	1
				392*	17Z084	BOARD, assembly (includes 166, 393, 394)	1
				393*	17V519	SCREW, pan hd	2
				394*	131718	COVER, dust, usb	2
40	24Y665	FRAME, handle upright, painted	1	400	24Y641	BAR, handle	1
48	17J125	BRACKET, slide	2	403	128855	SWITCH, rocker	1
50	17J136	SCREW, hex, flange head	8	404	17J126	BRACKET, shroud	1
105	114659	GRIP, handle	2	405	17J128	BRACKET, switch	1
106	237686	WIRE, ground, assembly	1	406	24Y642	PLATE, control	1
108	194310	LEVER, actuator	1	407	120593	SCREW, mach, torx	11
109	17J123	PLATE, cover	1	408*	25A495	KIT, repair, charger board (includes 407)	1
112	102040	NUT, lock, hex	4	409		See Main Control Board Replacement , page 26	1
113	17J135	COVER, control, painted (Standard Series)	1	410	111280	NUT, locking	3
	17V517	COVER, control, painted (HP Auto Series)	1	411	15F776	GASKET, throttle	1
114	128978	SCREW, mach, slot hex wash hd	12	412	17J456	LABEL	1
146	120151	PLUG	2	415	119736	CLAMP	1
147	24Y643	CONTROL, throttle (includes 410, 411, 415)	1	434*	15K162	BLOCK	1
148		See Display Assembly Replacement , page 27	1	435*	17J236	SWITCH, push button	1
149	16W408	KNOB, t-handle, 1/4-20 thd stud	2	437*	C20004	SCREW, cap	1
166*	17V520	LABEL, usb	1				
	16D576	LABEL, made in USA (Standard Series)	1				
169	17J617	WIRE, harness	1				
201	107257	SCREW, thd forming	10				
205*	24X370	BATTERY, 22 AH, sealed (includes 373, 374)	1				
206*	17H644	SHELF, battery	1				
207*	126949	STRAP, battery	1				
208*	17H650	COVER, solenoid, automatic	1				
209*	25A486	SOLENOID, module (includes 212, 213, 217, 218)	1				
210*	24Y777	BRACKET, solenoid	1				
211*	25A487	CABLE, gun, solenoid, auto (includes 151, 212, 213)	1				
212*	128711	PIN, clevis, 5/16	1				
213*	15R598	CLIP, cotter, hairpin	1				
217*	110755	WASHER, plain	2				
218*	121114	NUT, hex, self locking	2				
219*	128712	CAP, dust	2				
233	101962	SCREW, set, sch	2				
234	25A255	SHAFT, flexible	1				
263*	15H108	LABEL, safety, warning, pinch	1				
268	17H698	BUSHING, pressure control, mount	1				
269	119775	NUT, panel	1				
270	115999	RING, retaining	1				
272	16Y408	KNOB, pressure control	1				
273	15A464	LABEL, control	1				
290	128856	CLAMP	2				
291	114687	CLIP, retainer	2				
293	17H701	GROMMET	1				
294	115483	NUT	2				
295	17K378	LABEL	1				
296	17K379	LABEL	1				
297	17K377	COVER, battery, painted	1				
298	16W503	LABEL, safety, ground	1				
310*	17K397	LABEL	1				
311*	17K396	LABEL	1				
373*	128131	SCREW	2				
374*	111307	WASHER	2				

*HP Auto Series only

Filter - 200HS

Ref	Part	Description	Qty
51	17K166	MANIFOLD	1
52	196179	FITTING, elbow, street	1
53	287285	CAP, filter (includes 54, 56)	1
54	15C766	TUBE, diffusion	1
55	25A465	FILTER, fluid	1
56	117285	PACKING, o-ring	1
57	111801	SCREW, cap, hex hd	2
58	24N516	TRANSDUCER, pressure control (includes 59)	1
59	111457	O-RING	1
60	15G331	PLUG, pipe	1
61	245103	VALVE, drain, assy (includes 63, 65, 66, 67, 68)	1
62	196178	ADAPTER, nipple	2
63	114708	SPRING, compression	1
64	196181	FITTING, nipple	1
65	15G563	HANDLE, valve	1
66	116424	NUT, cap	1
67	193709	SEAT, valve	1
68	193710	SEAL, seat, valve	1
80	25A877	KIT, repair, filter manifold	1

Parts Drawing - LineLazer V 200DC

-  Torque to 35-45 ft-lbs
(47.4-61.0 N·m)
-  Torque to 190-210 in-lbs
(21.4-23.7 N·m)
-  Torque to 365-385 in-lbs
(41.2-43.4 N·m)
-  Torque to 25-30 in-lbs
(2.8-3.3 N·m)

B-SIDE

A-SIDE

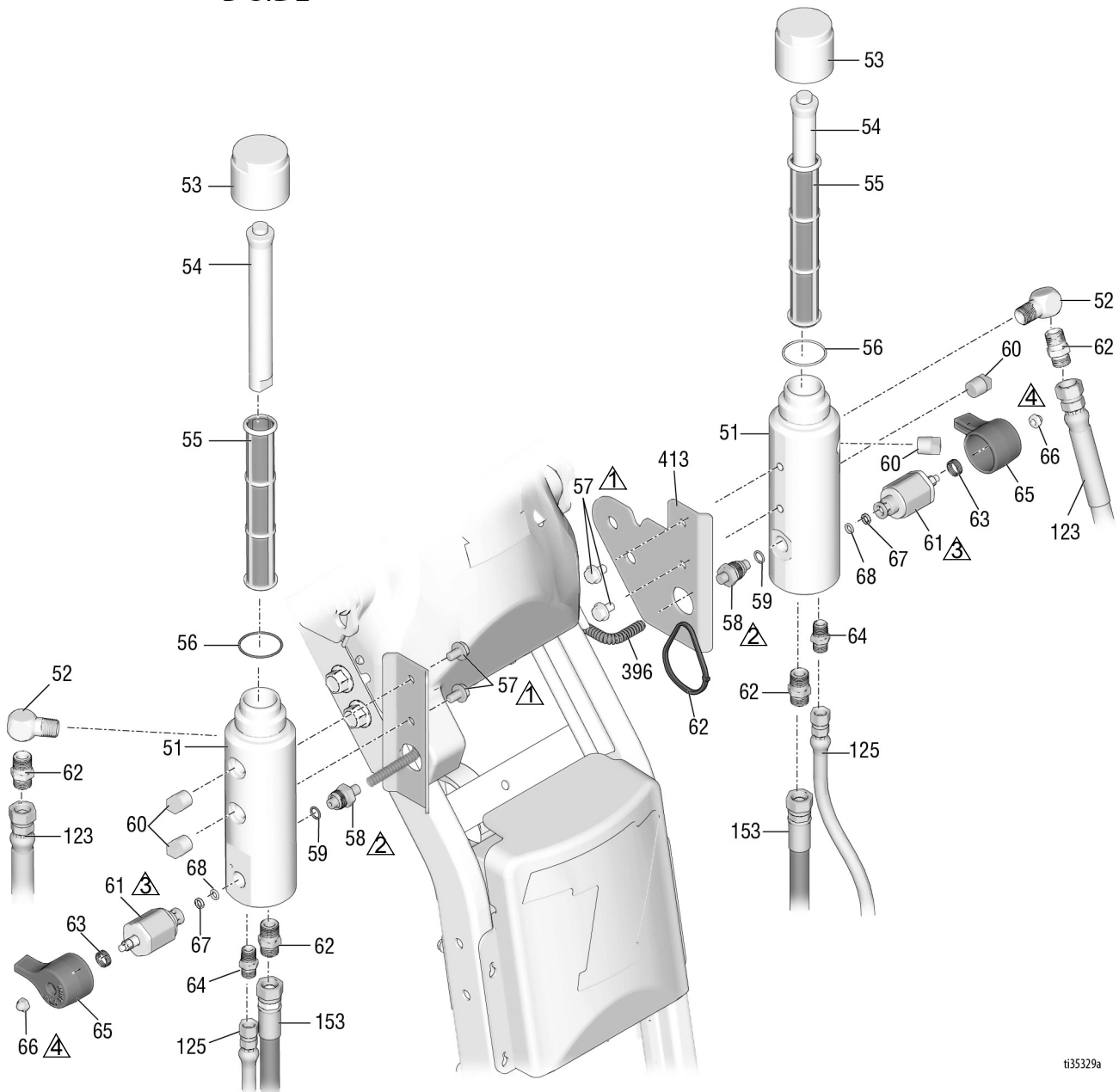

t35329a

Parts List - LineLazer V 200DC

Filters A & B

Ref	Part	Description	Qty	Ref	Part	Description	Qty
				65†	15G563	HANDLE, valve	1
				66†	116424	NUT, cap	1
51†	17K166	MANIFOLD	1	67†	193709	SEAT, valve	1
52†	196179	FITTING, elbow, street	1	68†	193710	SEAL, seat, valve	1
53†	17E680	CAP, filter	1	123	191239	HOSE, cpld, 3/8" x 11' 10"	2
54†	15C766	TUBE, diffusion	2	125	24V064	HOSE, suction/drain	2
55†	24V455	FILTER, fluid	1	153	245226	HOSE, cpld, 3/8" x 3'	1
56†	117285	PACKING, o-ring	1	197	17H720	STRAP, tie, black, 5"	1
57	111801	SCREW, cap, hex hd	2	396	17Y320	CONDUIT, sleeve, round, 7"	1
58†	248024	TRANSDUCER, pressure control	2	413	17Y104	BRACKET, manifold, filter	1
59†	111457	PACKING, o-ring	2				
60†	15G331	PLUG, pipe	1			Filter Manifold 'A' Kit, P/N 25N741	
61†	287879	VALVE, drain, assy	1			Filter Manifold 'B' Kit, P/N 25N742	
62†	196178	ADAPTER, nipple	1			† Included in Manifold 'A' or 'B' Kit	
63†	114708	SPRING, compression	1				
64†	196181	FITTING, nipple	1				

Parts Drawing - LineLazer V 200HS

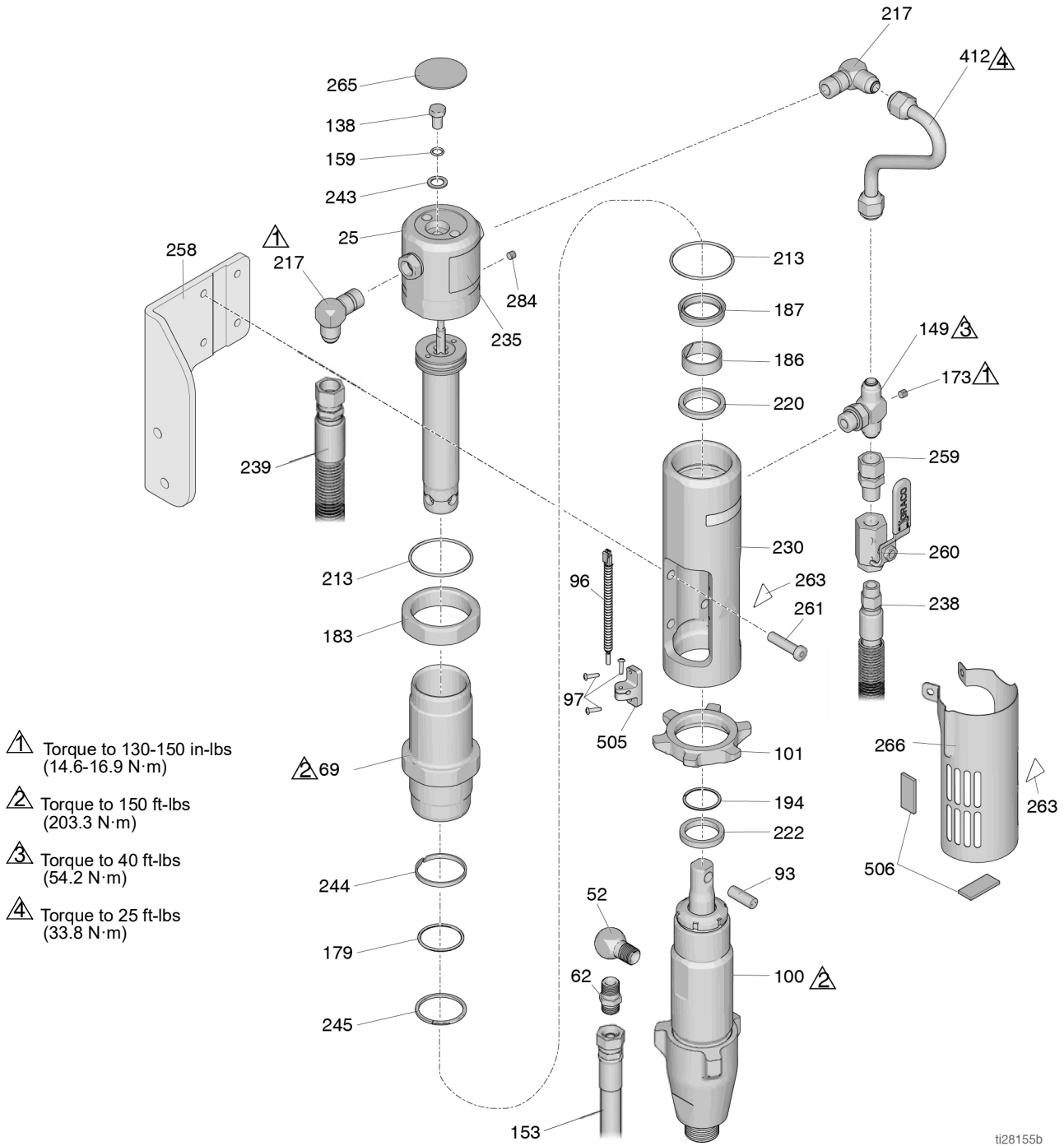

Parts List - LineLazer V 200HS

Ref.	Part	Description	Qty.	Ref.	Part	Description	Qty.
25	288754	KIT, repair, trip rod/piston	1	230	15A728	MANIFOLD, adapter	1
52	196179	FITTING, elbow, street	1	235	15B804	LABEL, graco logo	1
62	196178	ADAPTER, nipple	2	238	287175	HOSE, hydraulic, supply	1
69	246176	KIT, repair, sleeve, cylinder	1	243*	178179	WASHER, sealing	1
93	197443	PIN, pump	1	239	287176	KIT, repair, hose	1
96†	2006321	SWITCH, reed w/ connector	1	244*‡	178207	BEARING, piston	1
97†	114528	SCREW, mach, Phillips, pnhd	3	245*‡	178226	SEAL, piston	1
100	277068	PUMP, displacement	1	258	17H681	BRACKET, mount, pump, hydraulic	1
138*	106276	SCREW, cap, hex head	1	259	117328	FITTING, nipple, straight	1
101	193394	NUT, retaining	1	260	117441	VALVE, ball	1
149	119841	FITTING, tee, branch, str thd	1	261	107210	SCREW	4
159*	155685	PACKING, o-ring	1	263*▲	15H108	LABEL, warning, pinch point	2
153	245226	HOSE, coupled 3/8 x 3'	1	265▲	15B063	LABEL, safety, warning, hot surface	1
173	100139	PLUG, pipe	1	266	24X474	COVER, assy, pump rod	1
179*‡	108014	PACKING, o-ring	1	284*	100139	PLUG, pipe	1
183	15A726	NUT, jam	1	412	15F519	TUBE, hydraulic, supply	1
186*	112342	BEARING, rod	1	505†	2006622	BRACKET, reed	1
187‡	112561	PACKING, block	1	506†	2006691	GASKET, foam	2
194	116551	RING, retainer	1				
213*‡	117283	PACKING, o-ring	2				
217	117607	FITTING, elbow, std thd	2				
220*‡	117739	WIPER, rod	1				
222	287186	KIT, repair, magnet	1				

* Included in Trip Rod/Piston/Cap Repair Kit 288754

‡ Included in Hydraulic Seal Repair Kit 246174

† Included in Magnet Repair Kit 287186

▲ Replacement safety labels, tags, and cards are available at no cost.

Parts Drawing - LineLazer V 200DC

▲ Torque to 130-150 in-lbs
(14.6-16.9 N·m)

▲ Torque to 150 ft-lbs
(203.3 N·m)

▲ Torque to 40 ft-lbs
(54.2 N·m)

▲ Torque to 25 ft-lbs
(33.8 N·m)

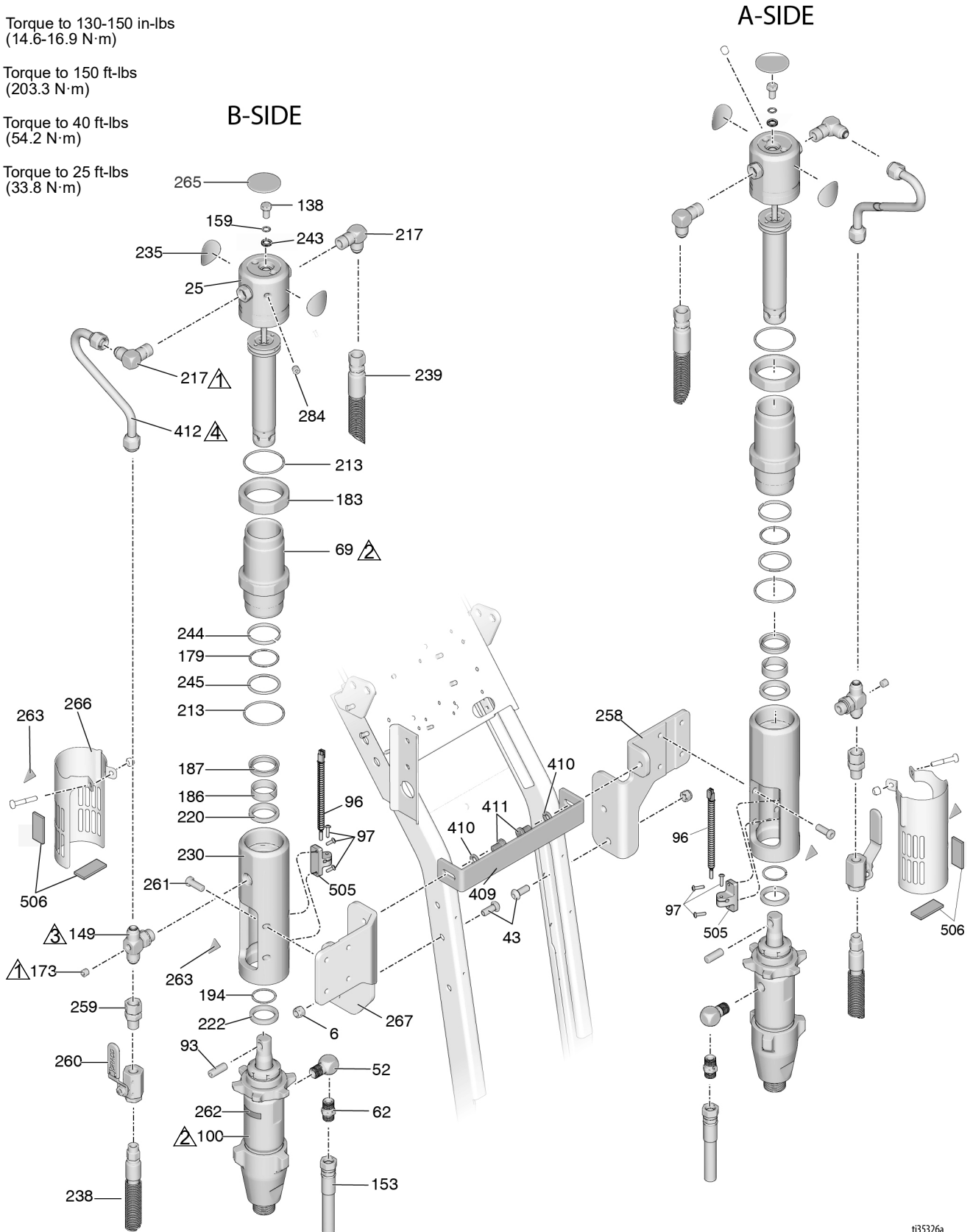

t35326a

Parts List - LineLazer V 200DC

Ref.	Part	Description	Qty.	Ref.	Part	Description	Qty.
6	101566	NUT, lock	4	239	287176	KIT, repair, hose	2
25	288754	KIT, repair, trip rod/piston	2	244*‡	178207	BEARING, piston	2
43	128977	SCREW, cap, button head, 3/8 x 1.0	4	245*‡	178226	SEAL, piston	2
52	196179	FITTING, elbow, street	2	258	17Y049	BRACKET, mount, pump, hydraulic, left	1
62	196178	ADAPTER, nipple	2	259	117328	FITTING, nipple, straight	2
69	246176	KIT, repair, sleeve, cylinder	2	260	117441	VALVE, ball	2
93	197443	PIN, pump	2	261	107210	SCREW	8
96†	2006321	SWITCH, reed 'A' side	1	262	194072	LABEL, endurance pump	2
97†	114528	SCREW, mach, Phillips, pnhd	3	263*▲	15H108	LABEL, warning, pinch point	4
100	277068	PUMP, displacement	2	265▲	15B063	LABEL, safety, warning, hot surface	2
138*	106276	SCREW, cap, hex head	2	266	24X474	COVER, assy, pump rod	2
149	119841	FITTING, tee, branch, str thd	2	267	17Y047	BRACKET, mount, pump, right	1
153	245226	HOSE, coupled 3/8 x 3'	2	284+	100139	PLUG, pipe	2
159*	155685	PACKING, o-ring	2	412	15F519	TUBE, hydraulic, supply	2
173	100139	PLUG, pipe	2	217	110755	WASHER, plain	4
179*‡	108014	PACKING, o-ring	2	213	15R598	CLIP, cotter, hairpin	2
183	15A726	NUT, jam	2	409	17Y050	BRACKET, reservoir, support, rear	1
186*	112342	BEARING, rod	2	410	100133	WASHER, lock, 3/8	2
187‡	112561	PACKING, block	2	411	100575	SCREW, cap, hex hd	2
194	116551	RING, retainer	2	414	2006322	SWITCH, reed, 'B' side	1
213*‡	117283	PACKING, o-ring	4	505†	2006622	BRACKET, reed	1
217	117607	FITTING, elbow, std thd	4	506†	2006691	GASKET, foam	2
220*‡	117739	WIPER, rod	2				
222	287186	KIT, repair, magnet	2				
230	15A728	MANIFOLD, adapter	2				
235	17Y328	LABEL, "A"	2				
	17Y329	LABEL "B"	2				
238	287175	HOSE, hydraulic, supply	2				
243*	178179	WASHER, sealing	2				

* Included in Trip Rod/Piston/Cap Repair Kit 288754

‡ Included in Hydraulic Seal Repair Kit 246174

† Included in Magnet Repair Kit 287186

▲ Replacement safety labels, tags, and cards are available at no cost.

Parts Drawing - LineLazer V 200HS / 200DC

 Torque to 115-135 in-lbs
(12.9-15.2 N·m)

 Torque to 190-210 in-lbs
(21.4-23.7 N·m)

 Torque to 58-62 in-lbs
(6.5-7.0N·m)

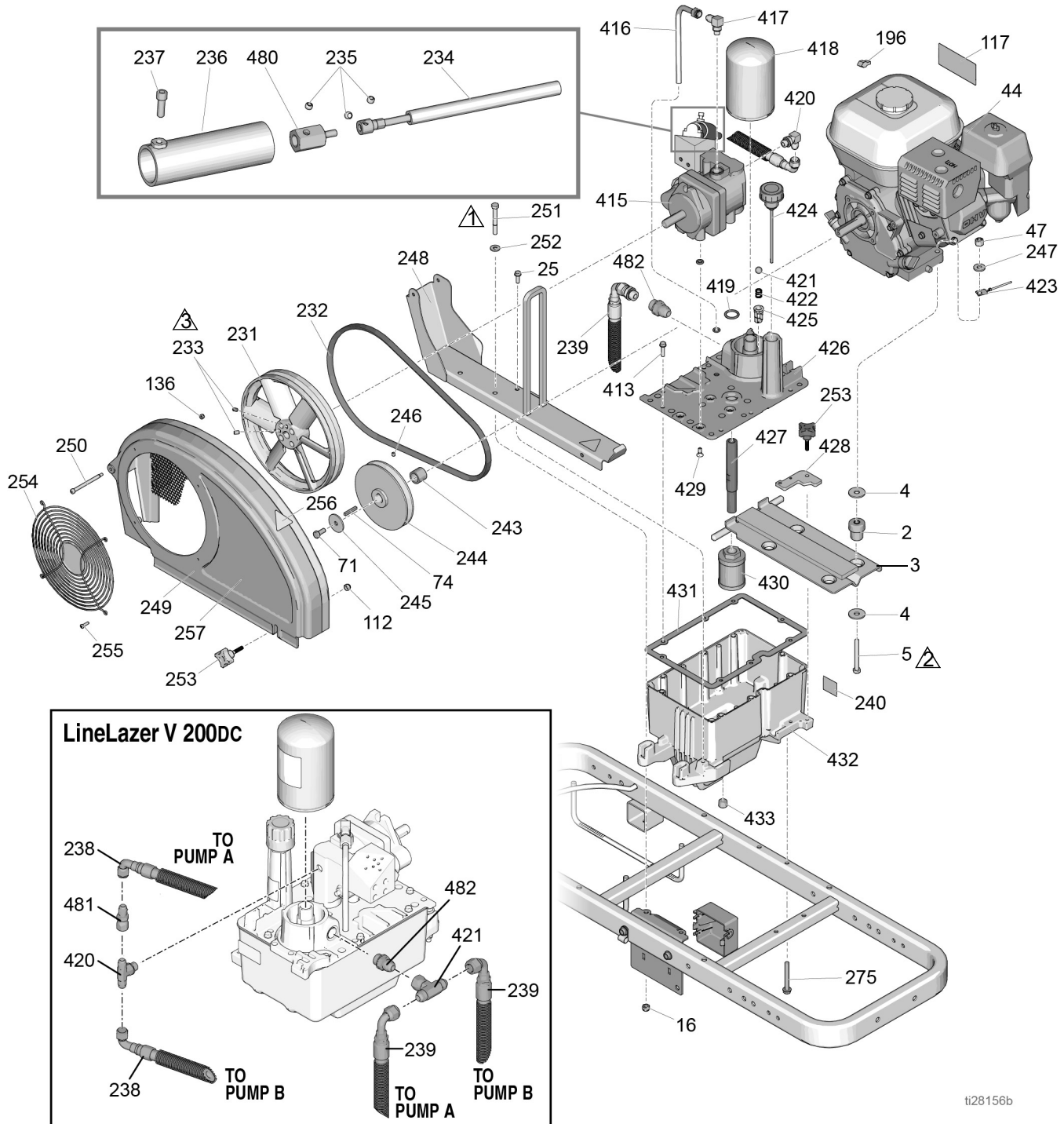

ti28156b

Parts List - LineLazer V 200HS / 200DC

Ref.	Part	Description	Qty.	Ref.	Part	Description	Qty.
2	15E888	DAMPENER, motor mount	4	254	117284	GRILL, fan, guard	1
3	15F485	BRACKET, mount, engine	1	255	115477	SCREW, mach, torx pan hd	4
4	108851	WASHER, plain	8	256▲	16M768	LABEL, warning, entanglement	2
5	113664	SCREW, cap, hex hd	4	257	17H689	LABEL, brand, LLV 200 HS	1
16	111040	NUT, lock, insert, nylock, 5/16	2		17Y292	LABEL, brand, LLV 200DC	1
25	260212	SCREW, hex, washer hd, thd form	2	275	120981	SCREW, mach, hex washer hd	2
44	116080	ENGINE	1	413	119426	SCREW, mach, hex washer hd	8
	25P296	ENGINE (China only)	1	414	107188	PACKING, o-ring	4
47	110838	NUT, lock	4	415	287179	KIT, repair, pump (includes 235, 414, 419, 429, 480)	1
71	108842	SCREW, cap, hex hd	1	416	246167	KIT, repair, case drain	1
74	117632	KEY, square, 3/16 x 1.25	1	417	110792	FITTING, elbow, male, 90°	1
112	102040	NUT, lock, hex	1	418	246173	KIT, repair, oil filter	1
117▲	194126	LABEL, warning	1	419	156401	PACKING, o-ring	1
136	116969	NUT, lock	1	420	116829	FITTING, elbow, hydraulic (200HS)	1
196	114956	TERMINAL, wire tap, insulated	1		17V730	FITTING, tee (200DC)	1
231	16U205	PULLEY, fan	1	421	100084	BALL, metallic	1
232	119433	BELT	1	422	116967	SPRING, compression	1
233	120087	SCREW, set, 1/4 x 1/2	2	423	240997	CONDUCTOR, ground	1
234	25A255	SHAFT, flexible, hydraulic control	1	424	120726	CAP, breather, filler	1
235	112303	SCREW, set, socket w/ patch	3	425	198841	RETAINER, ball, pressure bypass	1
236	15C958	GUARD, pressure control	1	426	15M057	COVER, reservoir	1
237	112166	SCREW, cap, sch	7	427	15E587	TUBE, suction	1
239	15C364	HOSE, hydraulic, return	2	428	15E476	BRACKET, retainer, motor	1
240	15K440	LABEL, brand, GH EH cooling	1	429	117471	SCREW, mach, hex flat head	4
243	15B314	SLEEVE, motor shaft	1	430	116919	FILTER, screen, suction	1
244	15E758	PULLEY, 5.50 in.	1	431	120604	GASKET, reservoir	1
245	112717	WASHER	1	432	15J513	TANK, reservoir	1
246	100002	SCREW, set, sch	1	433	101754	PLUG, pipe, 3/8 nptf	1
247	100023	WASHER, flat	4	480	16Y407	ADAPTER	1
248	288261	RAIL, belt guard, assy	1	481	127596	FITTING, swivel (200DC)	1
249	288734	GUARD, belt (includes 136, 250, 254, 255)	1	482	120184	FITTING, hydraulic	1
250	119434	SCREW, shoulder, skt hd	1				
251	802277	SCREW, machine	2				
252	100527	WASHER, plain	2				
253	15D862	NUT, hand	2				

▲ Replacement safety labels, tags, and cards are available at no cost.

Parts Drawing - LineLazer V 200HS / 200DC

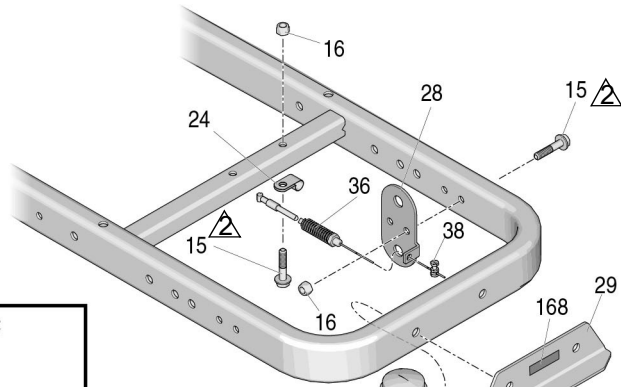

- Torque to 17-23 ft-lbs (23.0-31.1 N·m)
- Torque to 190-210 in-lbs (21.4-23.7 N·m)
- Torque to 23-27 ft-lbs (31.1-36.6 N·m)
- Torque to 60-80 in-lbs (6.7-9.0 N·m)
- Torque to 17-23 ft-lbs (23.0-31.1 N·m)

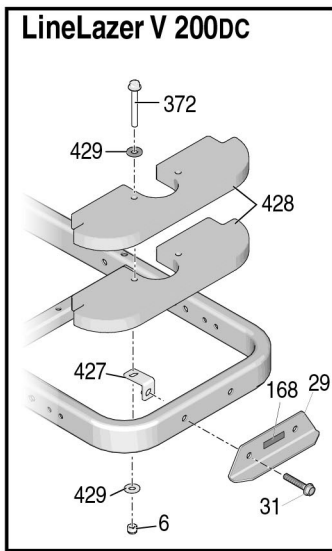

see page 10

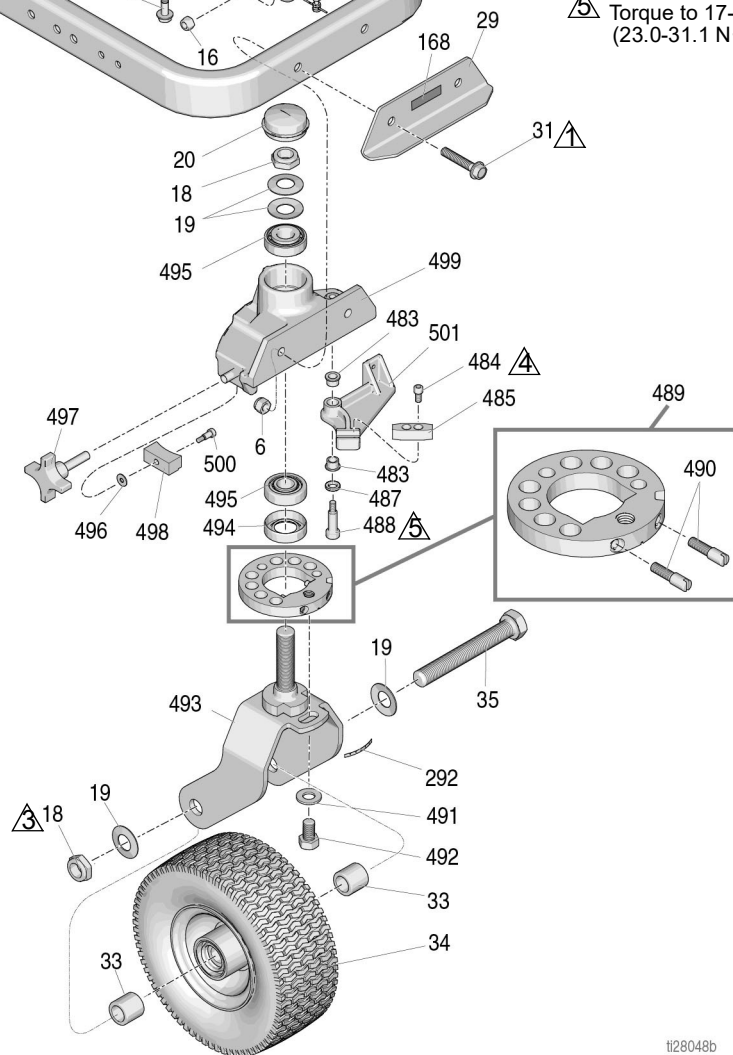

ti28048b

Parts List - LineLazer V 200HS / 200DC

Ref	Part	Description	Qty	Ref	Part	Description	Qty
6	101566	NUT, lock	2	483*‡	114548	BEARING, bronze	2
15	112960	SCREW, cap, flange hd	3	484*‡	110754	SCREW, cap, sch	2
16	111040	NUT, lock, insert, nylon, 5/16	3	485*‡	193662	STOP, wedge	1
18*‡	112405	NUT, lock	2	487*‡	15J603	SPACER, round	1
19*‡	112825	WASHER	4	488*‡	120476	BOLT, shoulder	1
20*‡	114648	CAP, dust	1	489*‡	17H486	DISK, adjuster, assembly	1
24	108868	CLAMP, wire	1	490*‡	17G762	SCREW, disk adjuster	2
28‡	15F910	BRACKET, cable	1	491*‡	113962	WASHER	1
29	240991	BRACKET, caster, front	1	492*	114681	SCREW, cap, hex hd	1
	25N653	KIT, weight, front	1	493*‡	17H485	FORK	1
31	114982	SCREW, cap, flange hd	2	494*‡	113484	SEAL, grease	1
33*‡	193658	SPACER, seal	2	495*‡	113485	BEARING, cup/cone	2
34*	114549	WHEEL, pneumatic	1	496*‡	112776	WASHER, plain	1
35*	113471	SCREW, cap, hex hd	1	497*‡	181818	KNOB, pronged	1
36‡	241445	CABLE	1	498*‡	193661	JAW	1
38‡	114802	STOP, wire	1	499*‡	15G952	CASTER	1
168	17H683	LABEL, EZ-Align	1	500*‡	108483	SCREW, shoulder	1
292*‡	17H489	LABEL, disk adjustment	1	501*‡	193528	ARM, detent	1
372	125626	SCREW, hex, hd, flanged	2				
427	17Y903	BRACKET, weight	2				
428	17Y900	BLOCK, weight	2				
429	100132	WASHER, flat	4				
						* Included in Swivel Wheel Repair Kit 240719	
						‡ Included in Swivel Wheel Repair Kit 241105	
						† Included in Weight Kit 25N653	

Main Control Board Replacement

1. Disconnect battery.

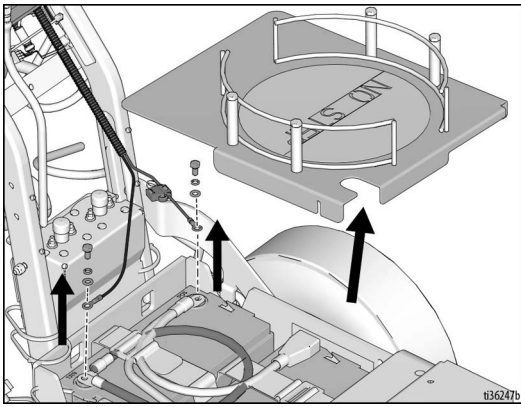
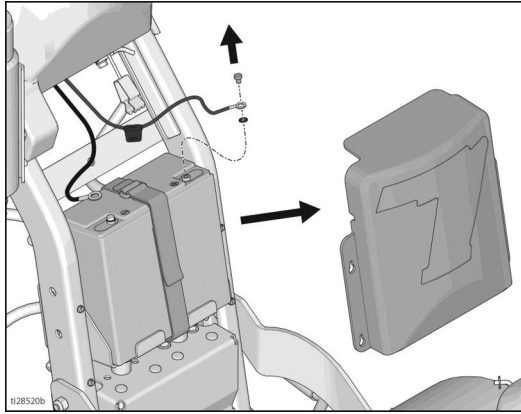

2. Remove screws on control board cover.

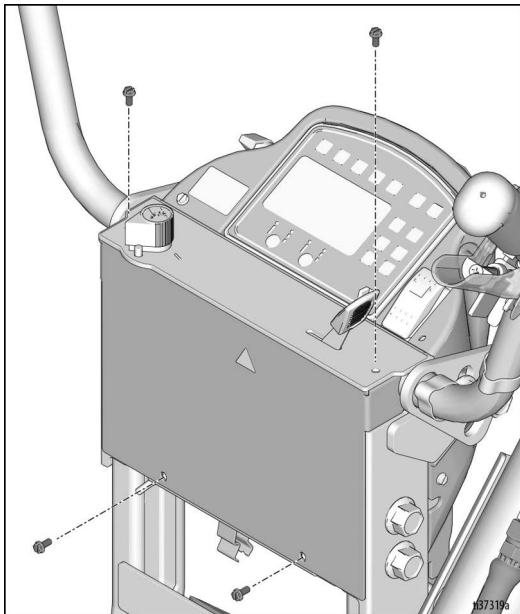

3. View label on surface of control board to find control board part number (PN). Use table below to select the correct replacement kit.

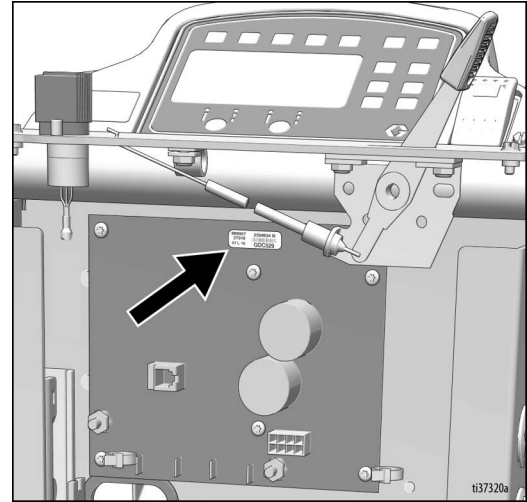

Control Board PN	Replacement Kit #
24Y310 or 25M844	25A493
24Y311 or 25M834	25A494
25N848	25N788
25N849	25N789

Display Assembly Replacement

1. Disconnect battery.

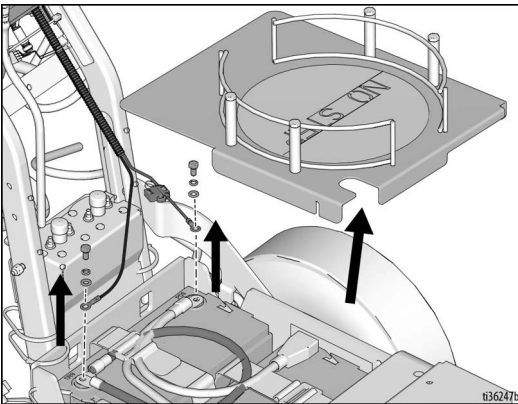
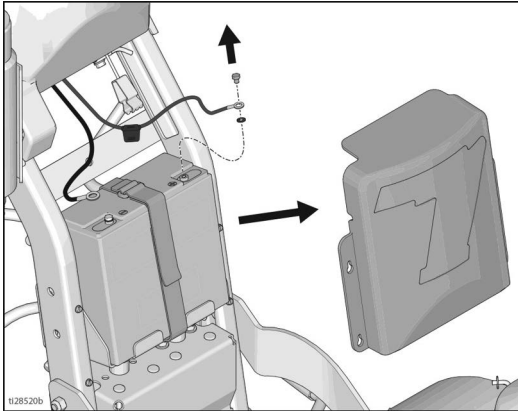

2. Remove screws on control board cover.

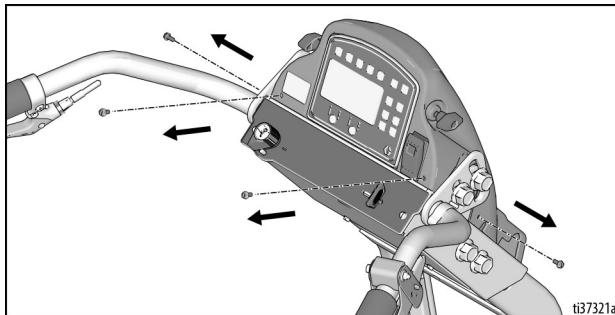

3. Lift display shroud off of unit. Carefully remove the display assembly from the shroud by loosening the hand nuts on either side.

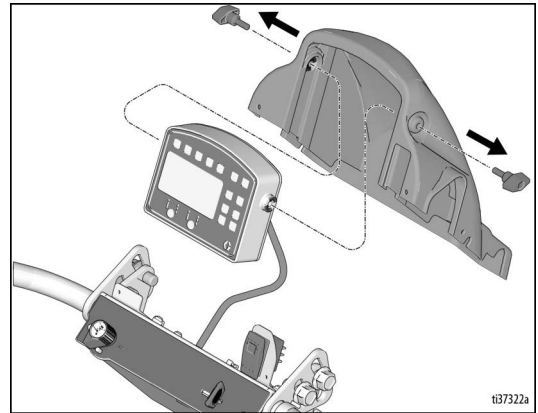

4. Remove the four screws from the back of the display assembly. Loosen the strain relief nut. Slide back panel to the side, being careful not to damage the wires connecting the display to the board.
5. View label on surface of display board to find display board part number (PN). Use table below to select the correct replacement kit.

Control Board PN	Replacement Kit #
24Y644	25A498
17V686	17W550
17Z168	25N791

Wiring Diagram 200HS (Standard Series)

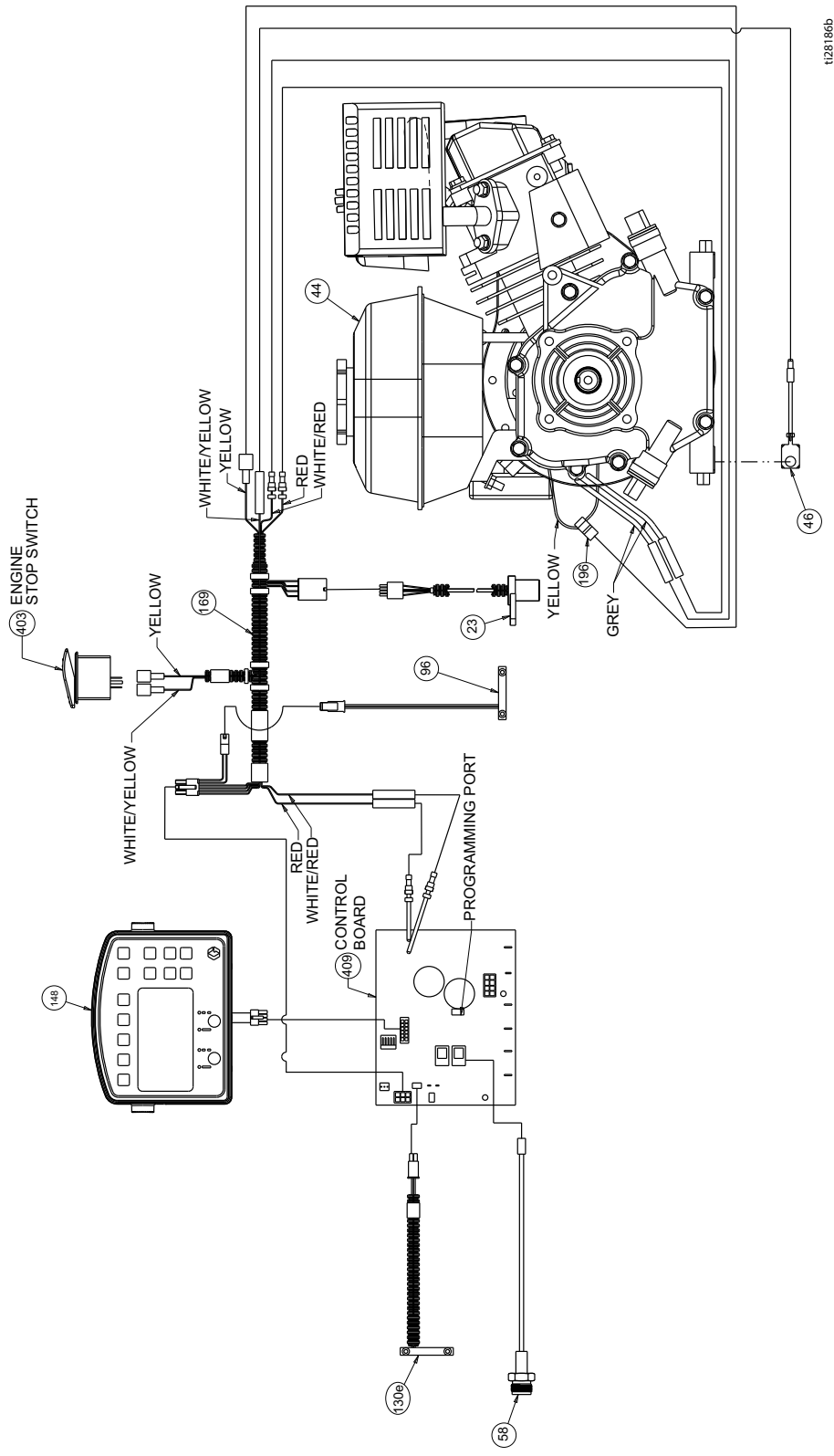

t1281865

Wiring Diagram 200DC (Standard Series)

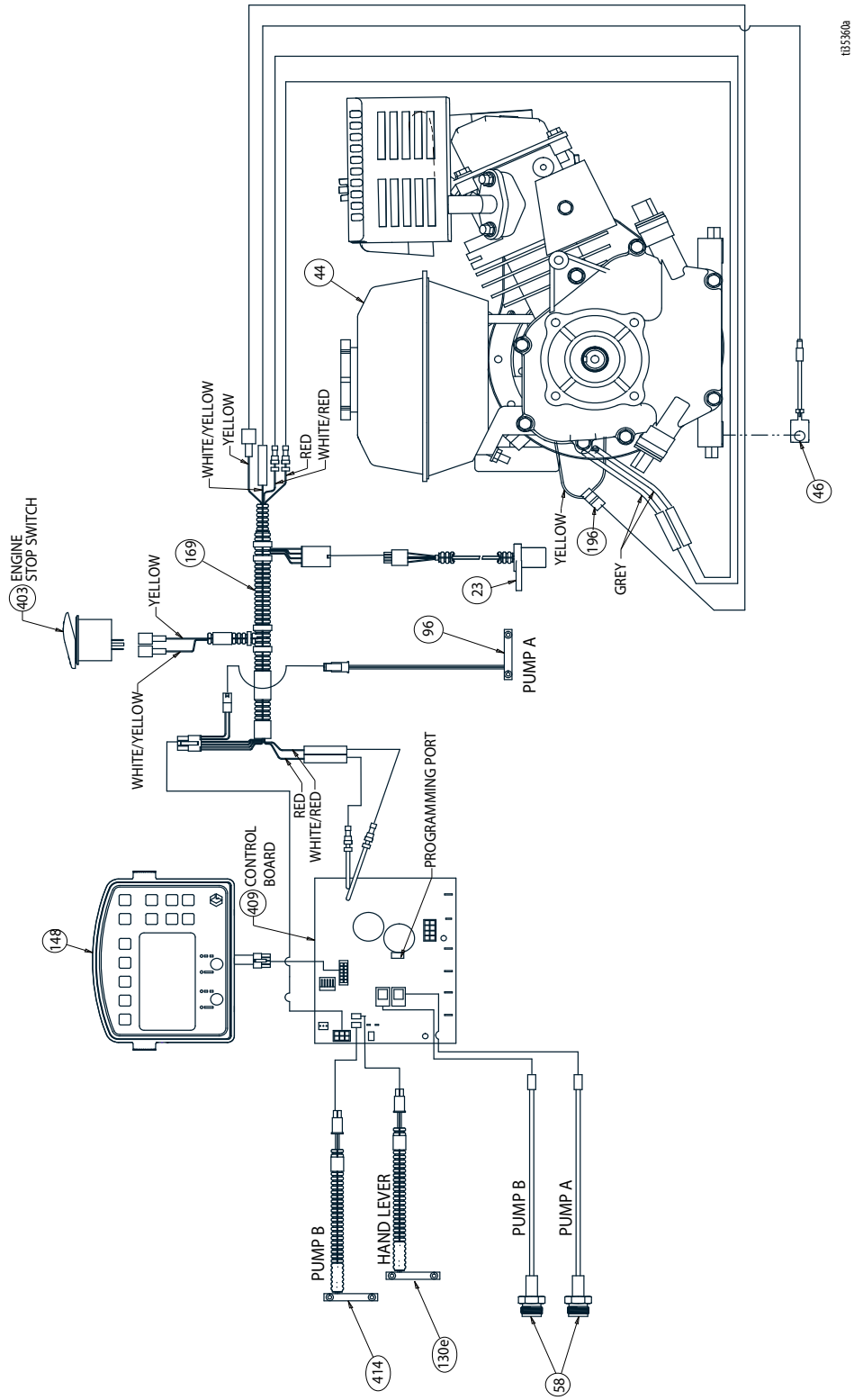

Wiring Diagram 200HS (HP Auto Series/HP Reflective Series)

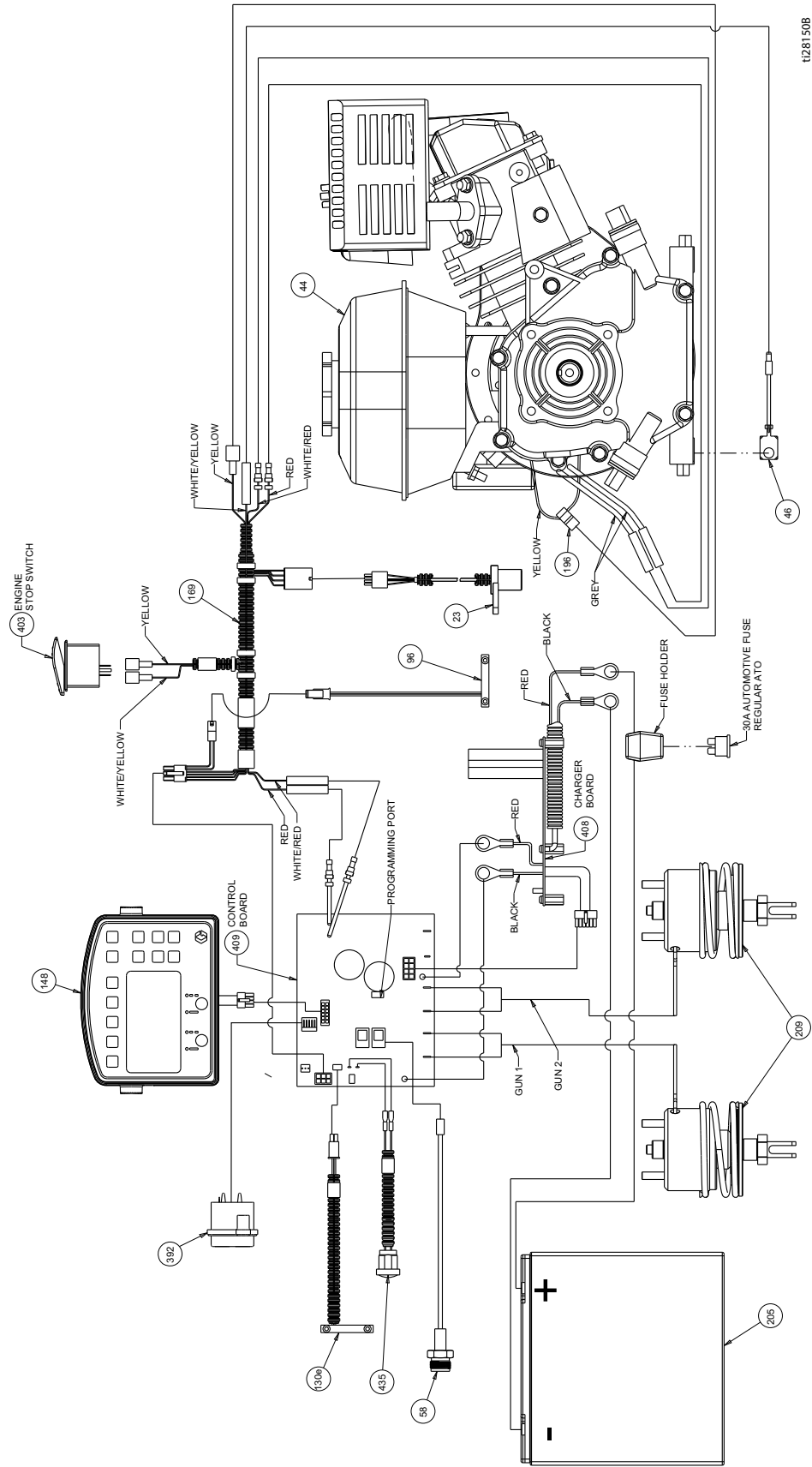

Wiring Diagram 200DC (HP Auto Series/HP Reflective Series)

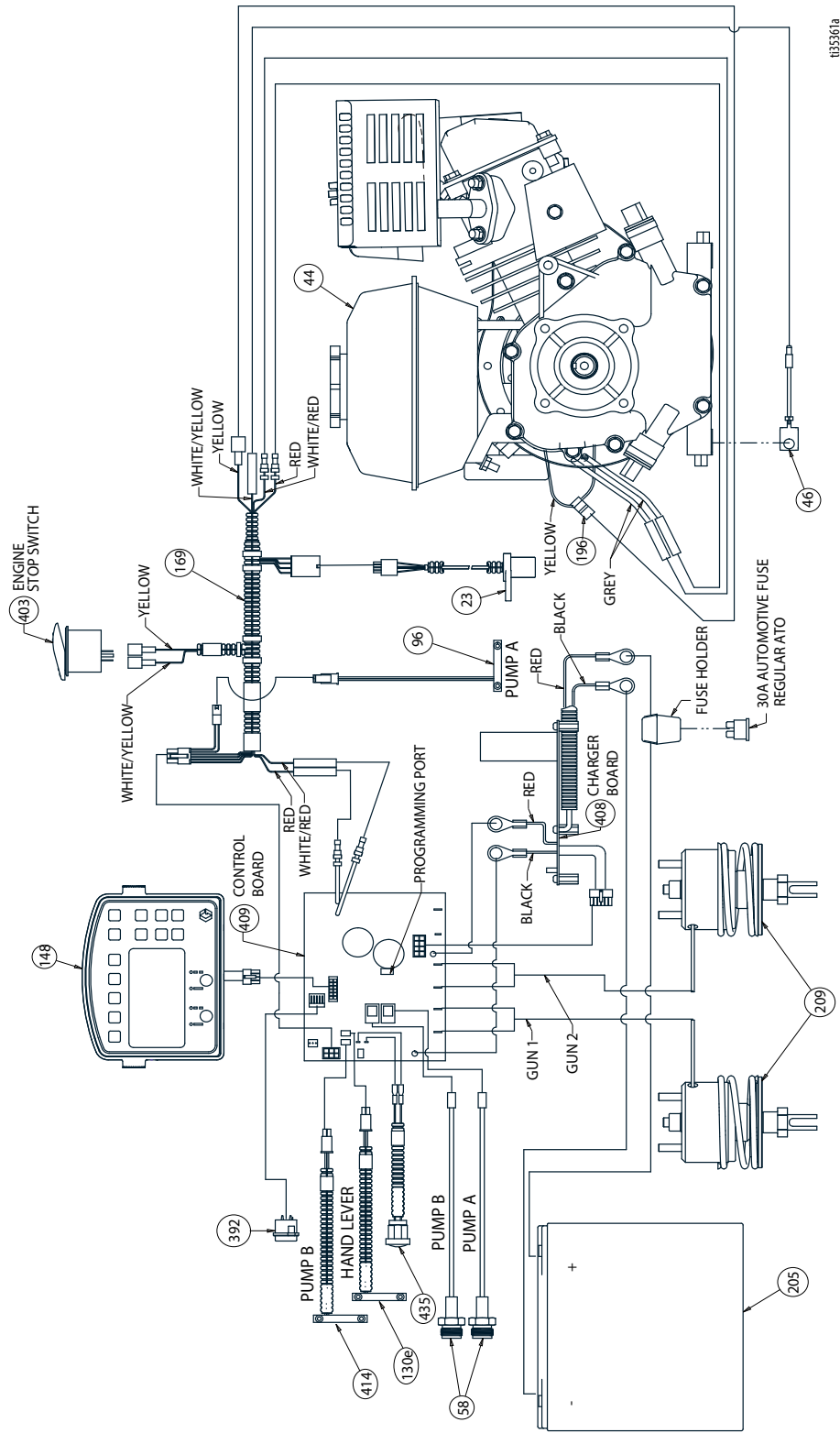

135361a

Technical Specifications

LineLazer V 200HS Standard Series (Models 17H459, 17H461)		
	U.S.	Metric
Dimensions		
Height (with handle bar down)	Unpackaged - 44.5 in. Packaged - 52.5 in.	Unpackaged - 113.03 cm Packaged - 133.35 cm
Width	Unpackaged - 34.25 in. Packaged - 37.0 in.	Unpackaged - 87.0 cm Packaged - 93.98 cm
Length (with platform down)	Unpackaged - 68.75 in. Packaged - 73.5 in.	Unpackaged - 174.63 cm Packaged - 186.69 cm
Weight (dry - no paint)	Unpackaged - 306 lbs Packaged - 373 lbs	Unpackaged - 139 kg Packaged - 169 kg
Noise (dBa)		
Sound Power per ISO 3744:	103.1	
Sound Pressure measured at 3.3 feet (1m):	86.5	
Vibration (m/s²) (8 hours daily exposure)		
Hand Arm (per ISO 5349)	1.6	
Whole Body (per ISO 2631)	0.4	
Power Rating (Horse Power)		
Power Rating (Horse Power) per SAE J1349	6.5 HP @ 3600 rpm	4.84 kW @ 3600 rpm
Maximum Delivery	2.15 gpm	8.14 lpm
Maximum Tip Size 1 gun 2 gun	.047 .034	
Inlet paint strainer	16 mesh	1190 micron
Outlet paint strainer	50 mesh	297 micron
Pump inlet size	1 in. NSPM (m)	
Pump outlet size	3/8 NPT (f)	
Maximum working pressure	3300 psi	228 bar, 22.8 MPa
Maximum fluid working pressure	3300 psi	228 bar, 22.8 MPa
Maximum free-flow delivery	2.15 gpm	8.14 lpm
Cycles per gallon/liter	62 cpg	16.4 cpl
Hydraulic reservoir capacity	1.25 gallons	4.73 liters
Hydraulic pressure	1825 psi	124 bar
Electrical Capacity	84 W @ 3800 rpm	
Battery	12V, 22Ah, Sealed lead acid, Deep cycle	

Wetted Parts: PTFE, Nylon, polyurethane, V-Max, UHM-WPE, fluoroelastomer, acetal, leather, tungsten carbide, stainless steel, chrome plating, nickel-plated carbon steel, ceramic

LineLazer V 200DC Standard Series (Model 17Y231)		
	U.S.	Metric
Dimensions		
Height (with handle bar down)	Unpackaged - 44.5 in. Packaged - 52.5 in.	Unpackaged - 113.03 cm Packaged - 133.35 cm
Width	Unpackaged - 34.25 in. Packaged - 37.0 in.	Unpackaged - 87.0 cm Packaged - 93.98 cm
Length (with platform down)	Unpackaged - 68.75 in. Packaged - 73.5 in.	Unpackaged - 174.63 cm Packaged - 186.69 cm
Weight (dry - no paint)	Unpackaged - 411lbs Packaged - 477 lbs	Unpackaged - 186 kg Packaged - 216 kg
Noise (dBa)		
Sound Power per ISO 3744:	103.1	
Sound Pressure measured at 3.3 feet (1m):	86.5	
Vibration (m/s²) (8 hours daily exposure)		
Hand Arm (per ISO 5349)	1.6	
Whole Body (per ISO 2631)	0.4	
Power Rating (Horse Power)		
Power Rating (Horse Power) per SAE J1349	6.5 HP @ 3600 rpm	4.84 kW @ 3600 rpm
Maximum Delivery	2.15 gpm	8.14 lpm
Maximum Tip Size 1 gun 2 gun	.047 .034	
Inlet paint strainer	16 mesh	1190 micron
Outlet paint strainer	50 mesh	297 micron
Pump inlet size	1 in. NSPM (m)	
Pump outlet size	3/8 NPT (f)	
Maximum working pressure	3300 psi	228 bar, 22.8 MPa
Maximum fluid working pressure	3300 psi	228 bar, 22.8 MPa
Maximum free-flow delivery	2.15 gpm	8.14 lpm
Cycles per gallon/liter	62 cpg	16.4 cpl
Hydraulic reservoir capacity	1.25 gallons	4.73 liters
Hydraulic pressure	1825 psi	124 bar
Electrical Capacity	84 W @ 3800 rpm	
Battery	12V, 22Ah, Sealed lead acid, Deep cycle	

Wetted Parts: PTFE, Nylon, polyurethane, V-Max, UHMWPE, fluoroelastomer, acetal, leather, tungsten carbide, stainless steel, chrome plating, nickel-plated carbon steel, ceramic

LineLazer V 200HS HP Auto Series (Models 17K582, 17H462, 17K637, 17H463, 17K583, 17H464)		
	U.S.	Metric
Dimensions		
Height (with handle bar down)	Unpackaged - 44.5 in. Packaged - 52.5 in.	Unpackaged - 113.03 cm Packaged - 133.35 cm
Width	Unpackaged - 34.25 in. Packaged - 37.0 in.	Unpackaged - 87.0 cm Packaged - 93.98 cm
Length (with platform down)	Unpackaged - 68.75 in. Packaged - 73.5 in.	Unpackaged - 174.63 cm Packaged - 186.69 cm
Weight (dry - no paint)	Unpackaged - 322 lbs Packaged - 389 lbs	Unpackaged - 146 kg Packaged - 176 kg
Noise (dBa)		
Sound Power per ISO 3744:	103.1	
Sound Pressure measured at 3.3 feet (1m):	86.5	
Vibration (m/s²) (8 hours daily exposure)		
Hand Arm (per ISO 5349)	1.6	
Whole Body (per ISO 2631)	0.4	
Power Rating (Horse Power)		
Power Rating (Horse Power) per SAE J1349	6.5 HP @ 3600 rpm	4.84 kW @ 3600 rpm
Maximum Delivery	2.15 gpm	8.14 lpm
Maximum Tip Size		
1 gun	.047	
2 gun	.034	
Inlet paint strainer	16 mesh	1190 micron
Outlet paint strainer	50 mesh	297 micron
Pump inlet size	1 in. NSPM (m)	
Pump outlet size	3/8 NPT (f)	
Maximum working pressure	3300 psi	228 bar, 22.8 MPa
Maximum fluid working pressure	3300 psi	228 bar, 22.8 MPa
Maximum free-flow delivery	2.15 gpm	8.14 lpm
Cycles per gallon/liter	62 cpg	16.4 cpl
Hydraulic reservoir capacity	1.25 gallons	4.73 liters
Hydraulic pressure	1825 psi	124 bar
Electrical Capacity	84 W@ 3600 rpm	
Battery	12V, 22Ah, Sealed lead acid, Deep cycle	

Wetted Parts: PTFE, Nylon, polyurethane, V-Max, UHM-WPE, fluoroelastomer, acetal, leather, tungsten carbide, stainless steel, chrome plating, nickel-plated carbon steel, ceramic

LineLazer V 200DC HP Auto Series (Models 17Y232, 17Y269)		
	U.S.	Metric
Dimensions		
Height (with handle bar down)	Unpackaged - 44.5 in. Packaged - 52.5 in.	Unpackaged - 113.03 cm Packaged - 133.35 cm
Width	Unpackaged - 34.25 in. Packaged - 37.0 in.	Unpackaged - 87.0 cm Packaged - 93.98 cm
Length (with platform down)	Unpackaged - 68.75 in. Packaged - 73.5 in.	Unpackaged - 174.63 cm Packaged - 186.69 cm
Weight (dry - no paint)	Unpackaged - 427 lbs Packaged - 494 lbs	Unpackaged - 194 kg Packaged - 224 kg
Noise (dBa)		
Sound Power per ISO 3744:	103.1	
Sound Pressure measured at 3.3 feet (1m):	86.5	
Vibration (m/s²) (8 hours daily exposure)		
Hand Arm (per ISO 5349)	1.6	
Whole Body (per ISO 2631)	0.4	
Power Rating (Horse Power)		
Power Rating (Horse Power) per SAE J1349	6.5 HP @ 3600 rpm	4.84 kW @ 3600 rpm
Maximum Delivery	2.15 gpm	8.14 lpm
Maximum Tip Size 1 gun 2 gun	.047 .034	
Inlet paint strainer	16 mesh	1190 micron
Outlet paint strainer	50 mesh	297 micron
Pump inlet size	1 in. NSPM (m)	
Pump outlet size	3/8 NPT (f)	
Maximum working pressure	3300 psi	228 bar, 22.8 MPa
Maximum fluid working pressure	3300 psi	228 bar, 22.8 MPa
Maximum free-flow delivery	2.15 gpm	8.14 lpm
Cycles per gallon/liter	62 cpg	16.4 cpl
Hydraulic reservoir capacity	1.25 gallons	4.73 liters
Hydraulic pressure	1825 psi	124 bar
Electrical Capacity	84 W@ 3600 rpm	
Battery	12V, 22Ah, Sealed lead acid, Deep cycle	

Wetted Parts: PTFE, Nylon, polyurethane, V-Max, UHM-WPE, fluoroelastomer, acetal, leather, tungsten carbide, stainless steel, chrome plating, nickel-plated carbon steel, ceramic

LineLazer V 200HS HP Reflective Series (Models 17H460, 17J964, 17K585, 17H465)		
	U.S.	Metric
Dimensions		
Height (with handle bar down)	Unpackaged - 44.5 in. Packaged - 52.5 in.	Unpackaged - 113.03 cm Packaged - 133.35 cm
Width	Unpackaged - 34.25 in. Packaged - 37.0 in.	Unpackaged - 87.0 cm Packaged - 93.98 cm
Length (with platform down)	Unpackaged - 68.75 in. Packaged - 73.5 in.	Unpackaged - 174.63 cm Packaged - 186.69 cm
Weight (dry - no paint)	Unpackaged - 417 lbs Packaged - 484 lbs	Unpackaged - 189 kg Packaged - 219kg
Noise (dBa)		
Sound Power per ISO 3744:	103.1	
Sound Pressure measured at 3.3 feet (1m):	86.5	
Vibration (m/s²) (8 hours daily exposure)		
Hand Arm (per ISO 5349)	1.6	
Whole Body (per ISO 2631)	0.4	
Power Rating (Horse Power)		
Power Rating (Horse Power) per SAE J1349	6.5 HP @ 3600 rpm	4.84 kW @ 3600 rpm
Maximum Delivery	2.15 gpm	8.14 lpm
Maximum Tip Size 1 gun 2 gun	.047 .034	
Inlet paint strainer	16 mesh	1190 micron
Outlet paint strainer	50 mesh	297 micron
Pump inlet size	1 in. NSPM (m)	
Pump outlet size	3/8 NPT (f)	
Maximum working pressure	3300 psi	228 bar, 22.8 MPa
Maximum fluid working pressure	3300 psi	228 bar, 22.8 MPa
Maximum free-flow delivery	2.15 gpm	8.14 lpm
Cycles per gallon/liter	62 cpg	16.4 cpl
Hydraulic reservoir capacity	1.25 gallons	4.73 liters
Hydraulic pressure	1825 psi	124 bar
Electrical Capacity	84 W@ 3600 rpm	
Battery	12V, 22Ah, Sealed lead acid, Deep cycle	

Wetted Parts: PTFE, Nylon, polyurethane, V-Max, UHM-WPE, fluoroelastomer, acetal, leather, tungsten carbide, stainless steel, chrome plating, nickel-plated carbon steel, ceramic

LineLazer V 200DC HP Reflective Series (Models 17Y233, 17Y270, 17Y648)		
	U.S.	Metric
Dimensions		
Height (with handle bar down)	Unpackaged - 44.5 in. Packaged - 52.5 in.	Unpackaged - 113.03 cm Packaged - 133.35 cm
Width	Unpackaged - 34.25 in. Packaged - 37.0 in.	Unpackaged - 87.0 cm Packaged - 93.98 cm
Length (with platform down)	Unpackaged - 68.75 in. Packaged - 73.5 in.	Unpackaged - 174.63 cm Packaged - 186.69 cm
Weight (dry - no paint)	Unpackaged - 522 lbs Packaged - 589 lbs	Unpackaged - 237 kg Packaged - 267 kg
Noise (dBa)		
Sound Power per ISO 3744:	103.1	
Sound Pressure measured at 3.3 feet (1m):	86.5	
Vibration (m/s²) (8 hours daily exposure)		
Hand Arm (per ISO 5349)	1.6	
Whole Body (per ISO 2631)	0.4	
Power Rating (Horse Power)		
Power Rating (Horse Power) per SAE J1349	6.5 HP @ 3600 rpm	4.84 kW @ 3600 rpm
Maximum Delivery	2.15 gpm	8.14 lpm
Maximum Tip Size 1 gun 2 gun	.047 .034	
Inlet paint strainer	16 mesh	1190 micron
Outlet paint strainer	50 mesh	297 micron
Pump inlet size	1 in. NSPM (m)	
Pump outlet size	3/8 NPT (f)	
Maximum working pressure	3300 psi	228 bar, 22.8 MPa
Maximum fluid working pressure	3300 psi	228 bar, 22.8 MPa
Maximum free-flow delivery	2.15 gpm	8.14 lpm
Cycles per gallon/liter	62 cpg	16.4 cpl
Hydraulic reservoir capacity	1.25 gallons	4.73 liters
Hydraulic pressure	1825 psi	124 bar
Electrical Capacity	84 W@ 3600 rpm	
Battery	12V, 22Ah, Sealed lead acid, Deep cycle	

Wetted Parts: PTFE, Nylon, polyurethane, V-Max, UHM-WPE, fluoroelastomer, acetal, leather, tungsten carbide, stainless steel, chrome plating, nickel-plated carbon steel, ceramic

Graco Standard Warranty

Graco warrants all equipment referenced in this document which is manufactured by Graco and bearing its name to be free from defects in material and workmanship on the date of sale to the original purchaser for use. With the exception of any special, extended, or limited warranty published by Graco, Graco will, for a period of twelve months from the date of sale, repair or replace any part of the equipment determined by Graco to be defective. This warranty applies only when the equipment is installed, operated and maintained in accordance with Graco's written recommendations.

This warranty does not cover, and Graco shall not be liable for general wear and tear, or any malfunction, damage or wear caused by faulty installation, misapplication, abrasion, corrosion, inadequate or improper maintenance, negligence, accident, tampering, or substitution of non-Graco component parts. Nor shall Graco be liable for malfunction, damage or wear caused by the incompatibility of Graco equipment with structures, accessories, equipment or materials not supplied by Graco, or the improper design, manufacture, installation, operation or maintenance of structures, accessories, equipment or materials not supplied by Graco.

This warranty is conditioned upon the prepaid return of the equipment claimed to be defective to an authorized Graco distributor for verification of the claimed defect. If the claimed defect is verified, Graco will repair or replace free of charge any defective parts. The equipment will be returned to the original purchaser transportation prepaid. If inspection of the equipment does not disclose any defect in material or workmanship, repairs will be made at a reasonable charge, which charges may include the costs of parts, labor, and transportation.

THIS WARRANTY IS EXCLUSIVE, AND IS IN LIEU OF ANY OTHER WARRANTIES, EXPRESS OR IMPLIED, INCLUDING BUT NOT LIMITED TO WARRANTY OF MERCHANTABILITY OR WARRANTY OF FITNESS FOR A PARTICULAR PURPOSE.

Graco's sole obligation and buyer's sole remedy for any breach of warranty shall be as set forth above. The buyer agrees that no other remedy (including, but not limited to, incidental or consequential damages for lost profits, lost sales, injury to person or property, or any other incidental or consequential loss) shall be available. Any action for breach of warranty must be brought within two (2) years of the date of sale.

GRACO MAKES NO WARRANTY, AND DISCLAIMS ALL IMPLIED WARRANTIES OF MERCHANTABILITY AND FITNESS FOR A PARTICULAR PURPOSE, IN CONNECTION WITH ACCESSORIES, EQUIPMENT, MATERIALS OR COMPONENTS SOLD BUT NOT MANUFACTURED BY GRACO. These items sold, but not manufactured by Graco (such as electric motors, switches, hose, etc.), are subject to the warranty, if any, of their manufacturer. Graco will provide purchaser with reasonable assistance in making any claim for breach of these warranties.

In no event will Graco be liable for indirect, incidental, special or consequential damages resulting from Graco supplying equipment hereunder, or the furnishing, performance, or use of any products or other goods sold hereto, whether due to a breach of contract, breach of warranty, the negligence of Graco, or otherwise.

FOR GRACO CANADA CUSTOMERS

The Parties acknowledge that they have required that the present document, as well as all documents, notices and legal proceedings entered into, given or instituted pursuant hereto or relating directly or indirectly hereto, be drawn up in English. Les parties reconnaissent avoir convenu que la rédaction du présente document sera en Anglais, ainsi que tous documents, avis et procédures judiciaires exécutés, donnés ou intentés, à la suite de ou en rapport, directement ou indirectement, avec les procédures concernées.

POUR LES CLIENTS DE GRACO PARLANT FRANCAIS

Les parties reconnaissent avoir convenu que la rédaction du présent document ainsi que de tous les documents, avis et procédures judiciaires exécutés, donnés ou intentés à la suite de ou en rapport, directement ou indirectement, avec les procédures concernées, sera en anglais.

ADDITIONAL WARRANTY COVERAGE

Graco does provide extended warranty and wear warranty for products described in the "Graco Contractor Equipment Warranty Program".

Graco Information

For the latest information about Graco products, visit www.graco.com.

For patent information, see www.graco.com/patents.

TO PLACE AN ORDER, contact your Graco distributor or call 1-800-690-2894 to identify the nearest distributor.

All written and visual data contained in this document reflects the latest product information available at the time of publication. Graco reserves the right to make changes at any time without notice.

Original instructions. This manual contains English. MM 3A3390

Graco Headquarters: Minneapolis

International Offices: Belgium, China, Japan, Korea

GRACO INC. AND SUBSIDIARIES • P.O. BOX 1441 • MINNEAPOLIS MN 55440-1441 • USA
Copyright 2016, Graco Inc. All Graco manufacturing locations are registered to ISO 9001.

www.graco.com
Revision H, May 2024