

ToughTek[®] F680e Fireproofing Pump

3A3110L

EN

Electric sprayer for water-based cementitious fireproofing materials. For professional use only. Not approved for use in explosive atmosphere or hazardous locations.



Important Safety Instructions

Read all warnings and instructions in this manual and all related manuals. **Save all instructions.**

600 psi (4.14 MPa, 41.4 bar) Maximum Working Fluid Pressure

For models, related manuals, and Agency approvals, see page 3.

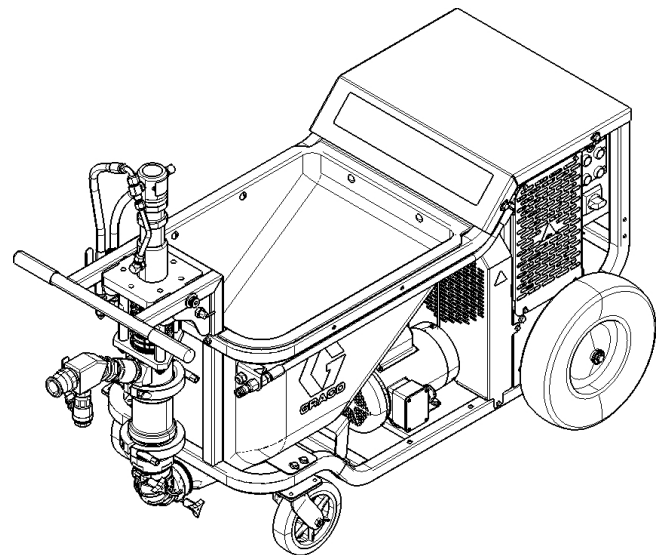

ti27126a

Contents

Models	3	Spray Adjustments (Pole Spray Applicator)	24
Related Manuals	3	Pressure Relief Procedure	26
Agency Approvals	3	Shutdown	27
Warnings	4	Corrosion Protection	27
Component Identification	7	Lifting Instructions	27
Overview.....	7	Maintenance	28
Sprayer Controls.....	8	Daily Maintenance.....	28
Pump Control Switch (AA).....	8	Preventative Maintenance.....	28
Fluid Drain/Purge Valve (C).....	9	Repair	29
Pump Components.....	9	Replace Pump Lower.....	29
Hydraulic Solenoid Valve (J).....	10	Partial Pump Lower Disassembly.....	30
Hydraulic Pressure Control (S).....	10	Replace Pump Components.....	31
Install the Remote Switch (17H197).....	10	Hydraulic Pump and Compressor Belt Repair..	34
Applicator Ball Valve (17J703).....	11	Parts	35
Hydraulic Ball Valve.....	11	F680e Parts.....	35
Pump Pivot Assembly.....	12	F680e Parts (continued).....	37
Installation	13	Enclosure Parts.....	41
Connect the Power.....	13	Breaker, Power Supply, Contact Module.....	42
Attach Power Cord.....	14	Reservoir Assembly Parts.....	43
Grounding	15	Pump Line Parts.....	44
Setup	15	Troubleshooting	46
Flush	17	Replacement Parts and Accessories	49
Mix the Material	20	Electrical Schematics	50
Prime with Material	20	Motor and Motor Control.....	51
Spray	22	Pump Control.....	53
Prevent Pack-out.....	22	Technical Specifications	54
Before Starting or Stopping Material Flow.....	22	Graco Standard Warranty	55
Spraying.....	22		

Models

Includes: ¹	Model (Series D)	
	200 - 240 VAC, 1 Φ , 60 Hz	
	35 A (24Y500)	25 A (24Y502)
Integrated Air Compressor	✓	

¹ For other parts included in all base models, see **Parts**, page 35. Some kits listed in **Parts** are not included in the base models listed above, but can be purchased with them (these kits are noted as such).

Related Manuals

Component manuals in English:

Manual	Description
3A3181	Forklift Stabilization Kit 24Y479









Manuals are available at www.graco.com

Agency Approvals

Approvals (All Models)

Warnings

The following warnings are for the setup, use, grounding, maintenance, and repair of this equipment. The exclamation point symbol alerts you to a general warning and the hazard symbols refer to procedure-specific risks. When these symbols appear in the body of this manual or on warning labels, refer back to these Warnings. Product-specific hazard symbols and warnings not covered in this section may appear throughout the body of this manual where applicable.

 <h2 style="margin: 0;">WARNING</h2>	
 	<p>ELECTRIC SHOCK HAZARD</p> <p>This equipment must be grounded. Improper grounding, setup, or usage of the system can cause electric shock.</p> <ul style="list-style-type: none"> • Turn off power before servicing equipment. • Connect only to grounded power source. • All electrical wiring must be done by a qualified electrician and comply with local codes and regulations. • Do not expose to rain. Store indoors.
   	<p>FIRE AND EXPLOSION HAZARD</p> <p>Flammable fumes, such as solvent and paint fumes, in work area can ignite or explode. To help prevent fire and explosion:</p> <ul style="list-style-type: none"> • Use equipment only in well ventilated area. • Eliminate all ignition sources; such as pilot lights, cigarettes, portable electric lamps, and plastic drop cloths (potential static sparking). • Ground all equipment in the work area. See Grounding instructions. • Keep work area free of debris, including solvent, rags and gasoline. • Do not plug or unplug power cords, or turn power or light switches on or off when flammable fumes are present. • Use only grounded hoses. • Hold applicator firmly to side of grounded pail when triggering into pail. Do not use pail liners unless they are antistatic or conductive. • Stop operation immediately if static sparking occurs or you feel a shock. Do not use equipment until you identify and correct the problem. • Keep a working fire extinguisher in the work area.
 	<p>MOVING PARTS HAZARD</p> <p>Moving parts can pinch, cut or amputate fingers and other body parts.</p> <ul style="list-style-type: none"> • Keep clear of moving parts. • Do not operate equipment with protective guards or covers removed. • Pressurized equipment can start without warning. Before checking, moving, or servicing equipment, follow the Pressure Relief Procedure and disconnect all power sources.
	<p>SUCTION HAZARD</p> <p>Powerful suction could cause serious injury.</p> <ul style="list-style-type: none"> • Never place hands near the pump fluid inlet when pump is operating or pressurized.

! WARNING



PRESSURIZED EQUIPMENT HAZARD

Fluid from the equipment, leaks, or ruptured components can splash in the eyes or on skin and cause serious injury.



- Follow the **Pressure Relief Procedure** when you stop spraying/dispersing and before cleaning, checking, or servicing equipment.
- Tighten all fluid connections before operating the equipment.
- Check hoses, tubes, and couplings daily. Replace worn or damaged parts immediately.



EQUIPMENT MISUSE HAZARD

Misuse can cause death or serious injury.



- Do not operate the unit when fatigued or under the influence of drugs or alcohol.
- Do not exceed the maximum working pressure or temperature rating of the lowest rated system component. See **Technical Specifications** in all equipment manuals.
- Use water and solvents that are compatible with equipment wetted parts. See **Technical Specifications** in all equipment manuals. Read fluid and solvent manufacturer's warnings. For complete information about your material, request Safety Data Sheets (SDSs) from distributor or retailer.
- Do not leave the work area while equipment is energized or under pressure.
- Turn off all equipment and follow the **Pressure Relief Procedure** when equipment is not in use.
- Check equipment daily. Repair or replace worn or damaged parts immediately with genuine manufacturer's replacement parts only.
- Do not alter or modify equipment. Alterations or modifications may void agency approvals and create safety hazards.
- Make sure all equipment is rated and approved for the environment in which you are using it.
- Use equipment only for its intended purpose. Call your distributor for information.
- Route hoses and cables away from traffic areas, sharp edges, moving parts, and hot surfaces.
- Do not kink or over bend hoses or use hoses to pull equipment.
- Keep children and animals away from work area.
- Comply with all applicable safety regulations.



PRESSURIZED ALUMINUM PARTS HAZARD

Use of fluids that are incompatible with aluminum in pressurized equipment can cause serious chemical reaction and equipment rupture. Failure to follow this warning can result in death, serious injury, or property damage.

- Do not use 1,1,1-trichloroethane, methylene chloride, other halogenated hydrocarbon solvents or fluids containing such solvents.
- Do not use chlorine bleach.
- Many other fluids may contain chemicals that can react with aluminum. Contact your material supplier for compatibility.

WARNING



TOXIC FLUID OR FUMES HAZARD

Toxic fluids or fumes can cause serious injury or death if splashed in the eyes or on skin, inhaled, or swallowed.

- Read Safety Data Sheet (SDSs) to know the specific hazards of the fluids you are using.
- Store hazardous fluid in approved containers, and dispose of it according to applicable guidelines.



BURN HAZARD

Equipment surfaces and fluid that is heated can become very hot during operation. To avoid severe burns:

- Do not touch hot fluid or equipment.



PERSONAL PROTECTIVE EQUIPMENT

Wear appropriate protective equipment when in the work area to help prevent serious injury, including eye injury, hearing loss, inhalation of toxic fumes, and burns. Protective equipment includes but is not limited to:

- Protective eyewear, and hearing protection.
- Respirators, protective clothing, and gloves as recommended by the fluid and solvent manufacturer.

Component Identification

Overview

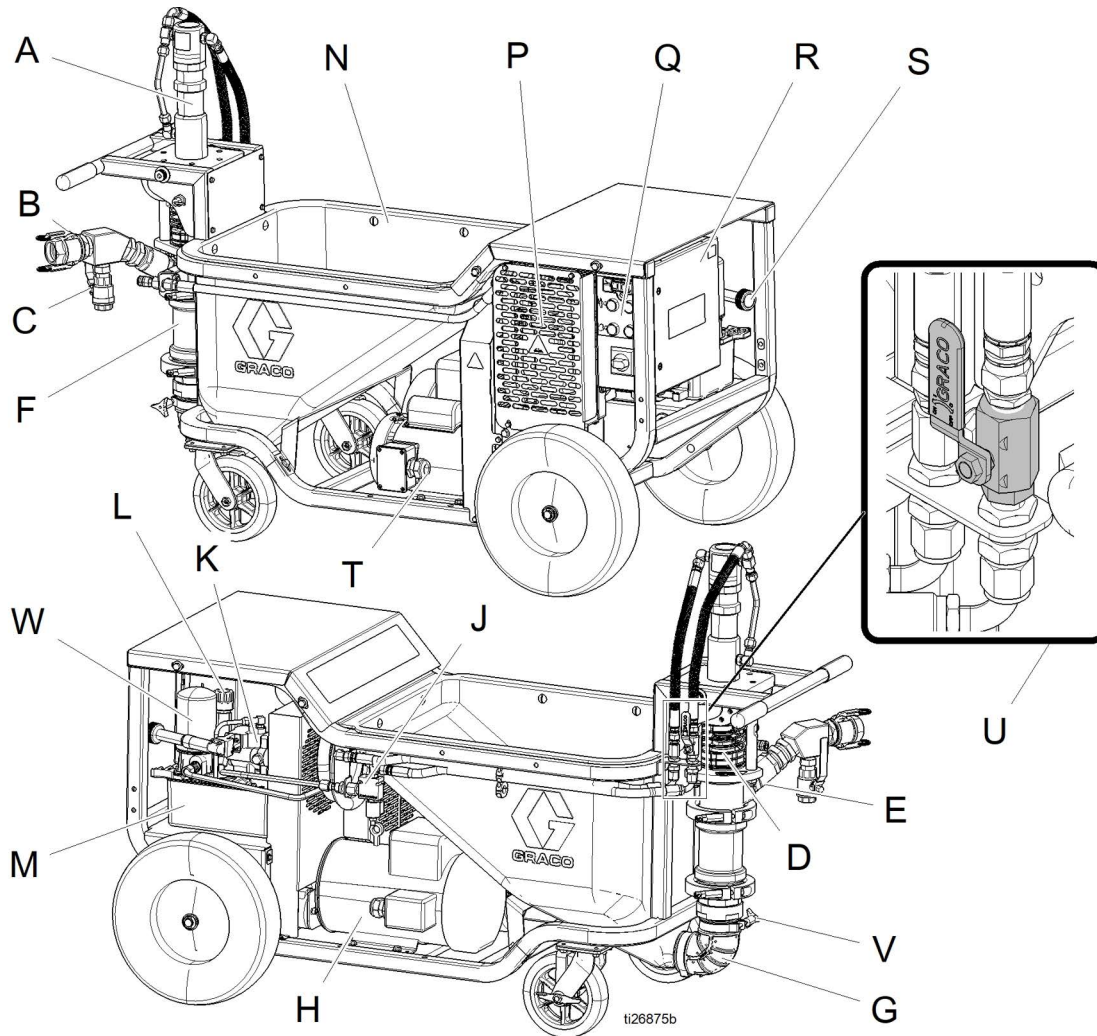

Component Identification Table

Key	Description	Key	Description
A	Hydraulic Driver	M	Hydraulic Reservoir
B	Fluid Outlet	N	Material Hopper
C	Fluid Drain / Purge Valve	P	Air Compressor
D	Packing Nut / Wet Cup	Q	Sprayer Controls
E	Outlet Check Valve	R	Electrical Control Box
F	Pump Lower	S	Hydraulic Pressure Control
G	Hopper Elbow	T	Electric Motor for Air Compressor
H	Electric Motor for Hydraulic Pump	Y	Hydraulic Ball Valve
J	Hydraulic Solenoid Valve	V	Hopper Elbow Clamp
K	Hydraulic Pump	W	Oil Filter
L	Oil Dipstick		

Sprayer Controls

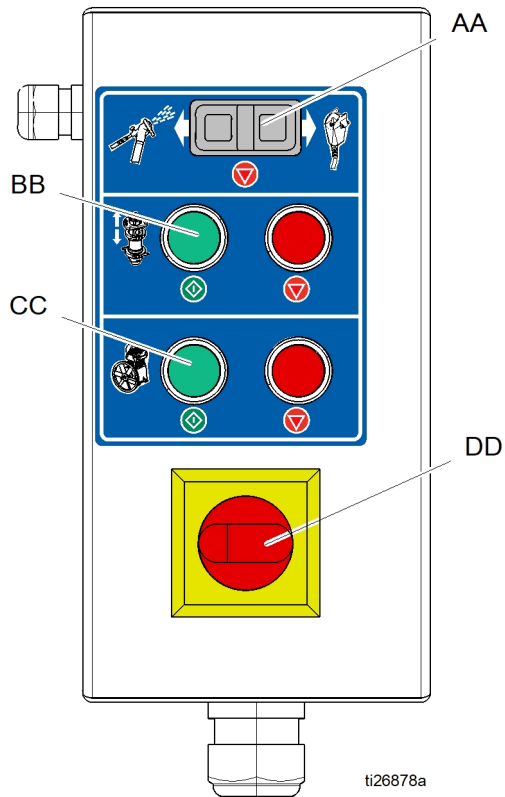



Ref.	Control	Description
AA	Pump Control Switch	Controls the pump lower.
BB	Hydraulic ON/OFF	Controls power to the electric motor that drives the hydraulic power.
CC	Compressor ON/OFF	Controls power to the electric motor that drives the compressor.
DD	Main Power Disconnect	Controls power to the sprayer.

Pump Control Switch (AA)

The pump control switch must be in the ON position or REMOTE position (with the remote control switch in the ON position) for the sprayer to pump material.

Pump Control Switch Settings:

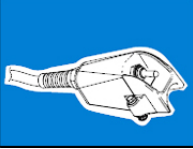
<p>OFF</p> 	<p>The pump line will not cycle. There is still power to the unit.</p>
<p>ON</p> 	<p>The pump line will cycle at a speed determined by the hydraulic pressure control.</p>
<p>REMOTE CONTROL</p> 	<p>The "Remote Control" setting controls ON/OFF functionality of the pump through the remote toggle switch (YY). When the remote toggle switch is installed and the pump control switch (AA) is set to "Remote Control", the toggle can be used to turn the pump ON and OFF (see descriptions above).</p>

Fluid Drain/Purge Valve (C)



To avoid injury from splashing fluid, never open a cam-lock hose or applicator fitting while there is pressure in the fluid line.

Open the drain/purge valve (C) to relieve pressure if pump or hose pack-out occurs, or to relieve pressure inside the hose. Close valve when spraying.

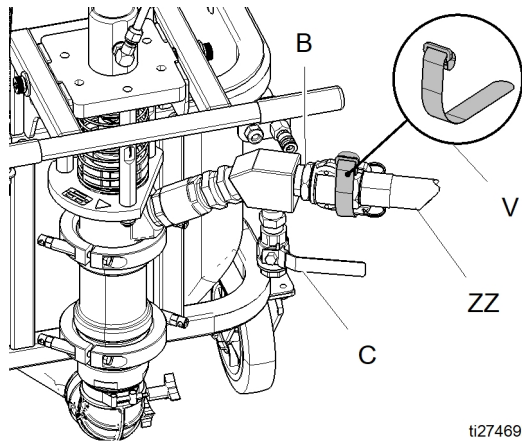

NOTICE

To prevent material hardening in fluid drain/purge valve, flush the valve after every time it is used. See **Flush**, page 17.

Pump Components

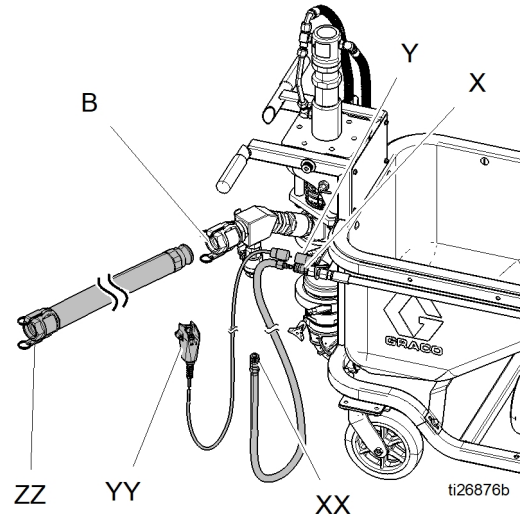

Ref.	Description
X	Air Outlet, 1/4 in. quick disconnect coupling fitting.
Y	Remote Switch Receptacle. The remote switch cable is plugged into this socket. Make sure the pump control switch (AA) is in the OFF position when connecting and disconnecting the remote switch cable to prevent unintended operation of the sprayer.
B	Fluid outlet, 1.5 in. cam and groove fitting
XX	Air Hose. It is recommended to use 1/2 in. ID air hose for at least the first 50 feet. For hose longer than 50 feet, use a 3/8 in. ID air hose.
YY	Remote toggle switch.
ZZ	Material hose.

Hydraulic Solenoid Valve (J)

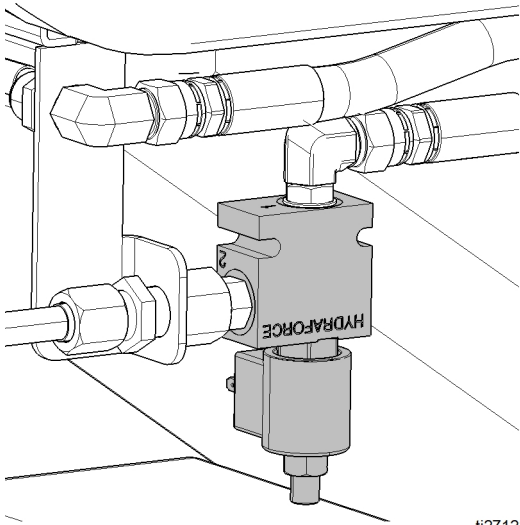

ti27128a

The hydraulic solenoid valve (J) is normally closed, so when de-energized (pump control switch (AA) in OFF position) it will block flow and the hydraulic pump will stall. When energized (pump control switch in the ON position, or REMOTE position with the remote switch in the ON position) it allows flow and the hydraulic pump to operate.

If the solenoid is not receiving a signal and remains closed when the pump control switch is in the ON position, it can be manually overridden. To override, push the red button in, turn counterclockwise 180° and release. The solenoid valve will then remain open at all times.

Hydraulic Pressure Control (S)

Use to adjust hydraulic pressure available to the hydraulic drive system. Turn the hydraulic pressure control (S) clockwise to increase pressure and counterclockwise to decrease pressure.

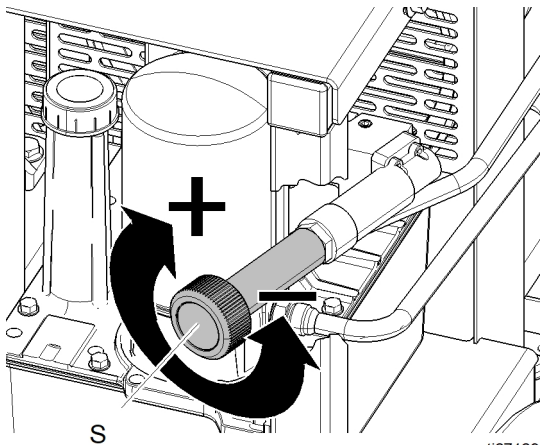

ti27129a

Install the Remote Switch (17H197)

NOTE: Use zip-tie (ZT) to install the remote switch to the hose or pole spray applicator (follow the illustrations below). The remote switch will fit on hoses/applicators sized .75 in. up to 1.25 in.

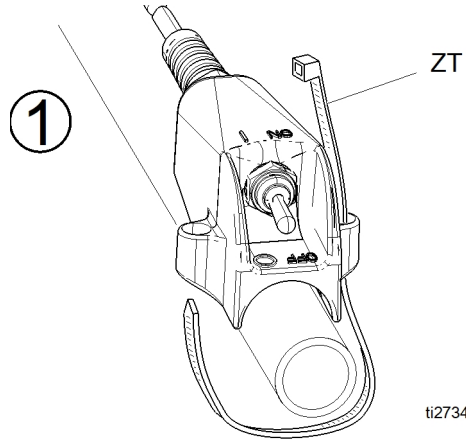

ti27347a

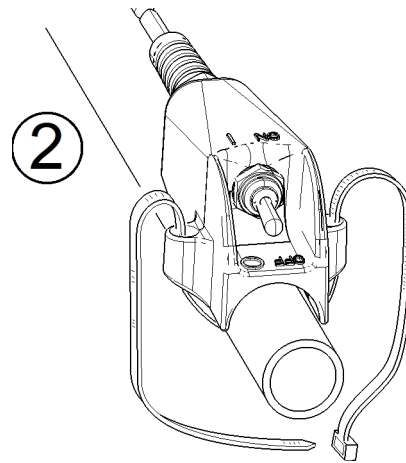

ti27293a

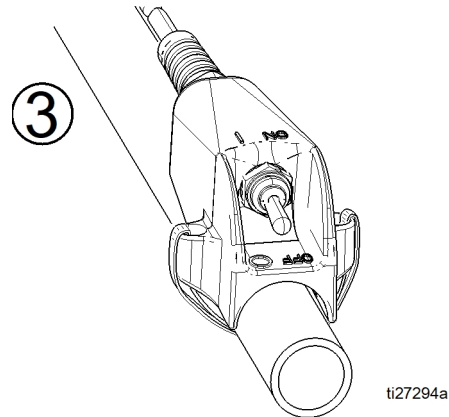

ti27294a

Applicator Ball Valve (17J703)

Additional accessory kit that can be installed on the end of the 1 in. ID, 25 ft material hose (115) directly between the pole spray applicator pipe handle and adapter fitting. The applicator ball valve (BV) can be used to stop material flow, but only after the pump has been stopped first. Do NOT use the valve to stall the pump.

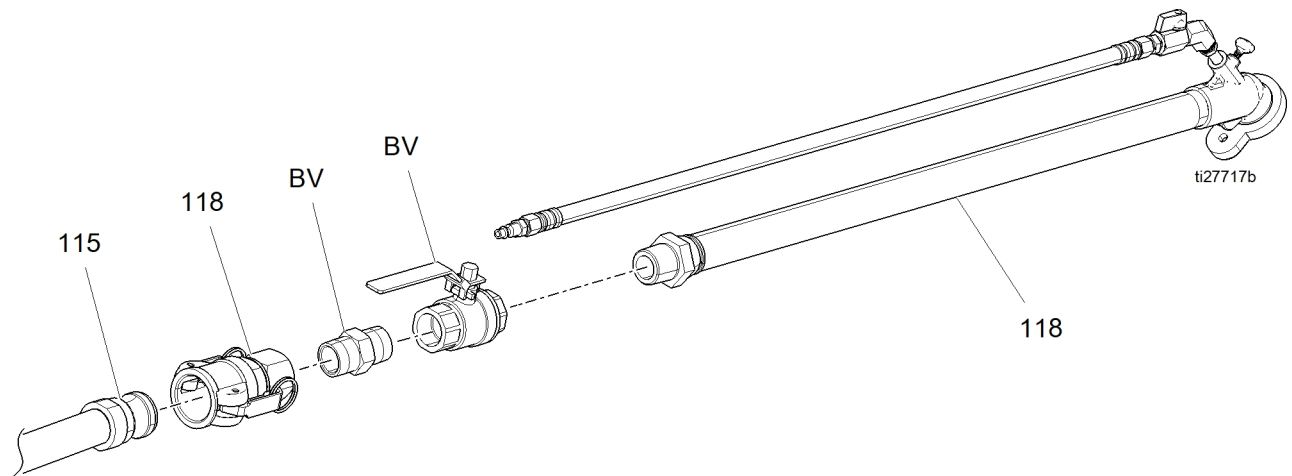

Hydraulic Ball Valve

When closed, the hydraulic ball valve will stop the pump from cycling. The ball valve must be open to pump material.

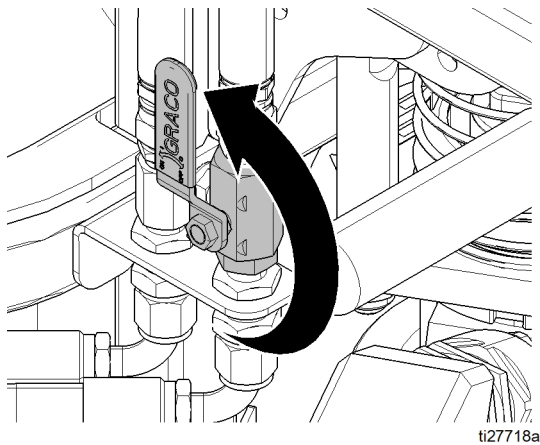

Pump Pivot Assembly

The pump pivot assembly allows easy detachment of the hopper from the pump.

To remove the pump from the hopper, loosen the hopper elbow clamps (V), retract the spring-loaded locking pin (Z), and slowly swing the pump up until the spring loaded locking pin clicks into place.

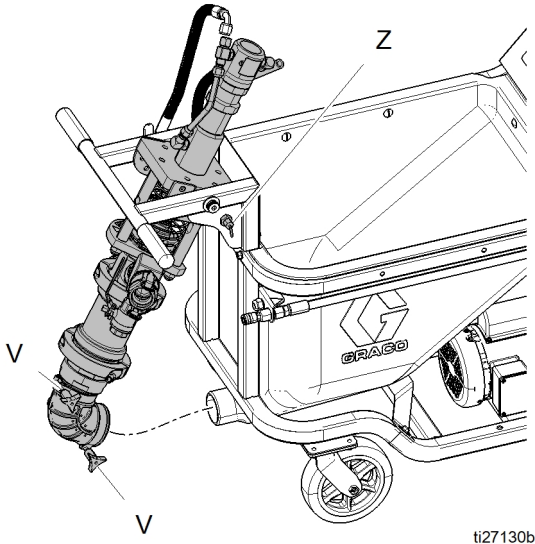

To attach the pump to the hopper, retract the spring-loaded locking pin (Z) and slowly lower the pump until the elbow fitting is flush with the hopper and the locking pin clicks into place. Tighten the hopper elbow clamps (V) so the elbow fitting seals tightly around the hopper outlet.

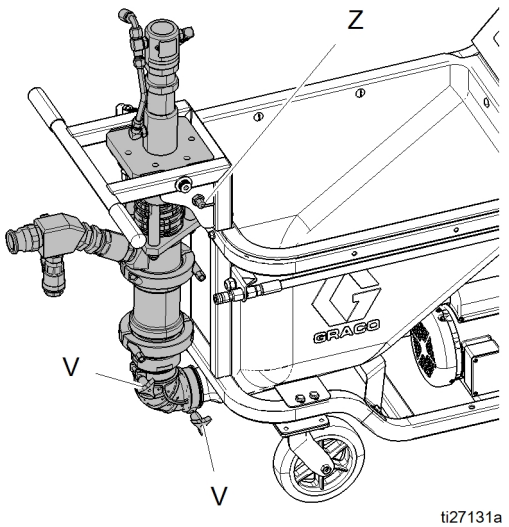

Installation

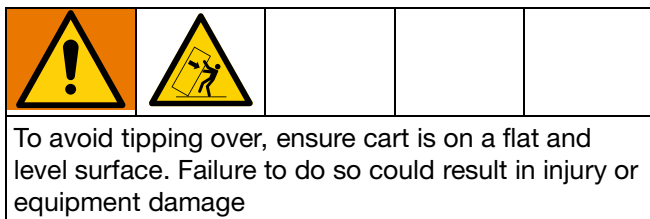

Connect the Power

See the table below for power supply requirements. The system requires a dedicated circuit protected with a circuit breaker.

Voltage	Phase	Hz	Integrated Air Compressor	Full Load Peak Current*	Cord Specifications AWG (mm ²)
200-240 VAC	1 Φ (2 wire + ground)	60	Yes	35 A	8 (10.0)
			No	25 A	12 (4.0)
* Full load amps with all devices operating at maximum capabilities. Fuse requirements at various pressures and flow rates may be less.					

NOTE: The disconnect terminals will accept up to #8 AWG (10 mm²) conductors.

Attach Power Cord



Improper wiring may cause electric shock or other serious injury. All electrical wiring must be done by a qualified electrician and comply with all local codes and regulations.

1. Strip outer jacket of power cord to expose 8 in. (20.3 cm) of conductors.

NOTE: Strip individual conductors and add ferrules as necessary.

2. Attach the power cord to the disconnect block (PD) located in the electrical control box (R). Bring the power cord into the electrical control box through the strain relief (SR).

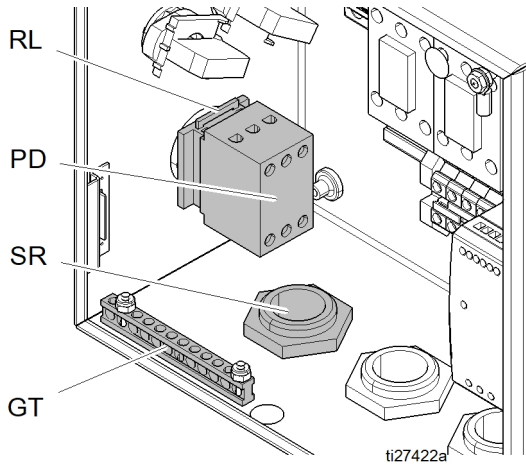



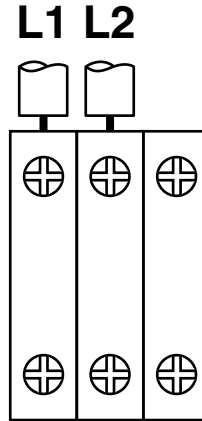

3. Install the power cord as shown below.

200-240 VAC, 1 phase: Use a screwdriver to connect two power leads as shown.



4. Connect the green ground wire to the ground terminal (GT).
5. Make sure the strain relief is tightened. Close the electrical control box.

Grounding

				
<p>The equipment must be grounded to reduce the risk of static sparking and electric shock. Electric or static sparking can cause fumes to ignite or explode. Improper grounding can cause electric shock. Grounding provides an escape wire for the electric current.</p>				

The system is grounded through the power cord.

Setup

1. Ground sprayer. See **Grounding**, page 15.
2. Check Throat Seal Liquid (TSL) level in packing nut (D). Fill 1/2 full with TSL.

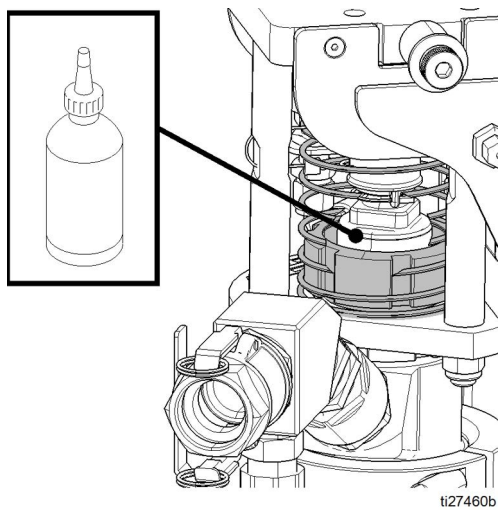

3. Connect air supply to applicator.

4. Attach fluid hose (ZZ) to applicator fluid inlet and fluid outlet (B), then secure Velcro straps (V) around the cam lock fitting.

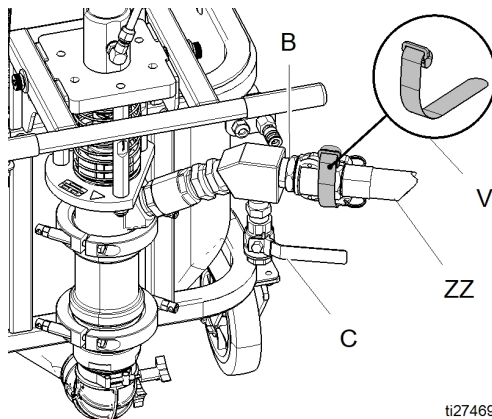

5. Turn hydraulic pressure control knob (S) counterclockwise to lowest pressure.

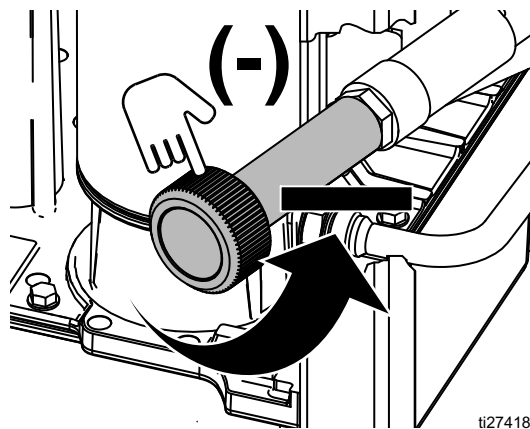

6. Set pump control switch (AA) to OFF.

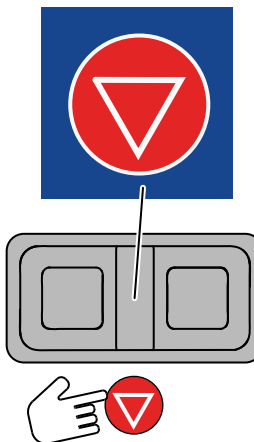

Grounding

7. Turn main power disconnect (DD) OFF. Connect unit to power source (see **Attach Power Cord**, page 14).

8. Flush the system with water before using (see **Flush**, page 17). When finished, pump out the excess water from the hopper (N).

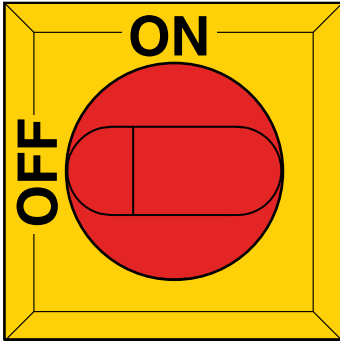

ti27415a

Flush



NOTICE

Failure to flush prior to material curing in the system will result in damage to system and may require replacement of all system parts in contact with the material.

NOTICE

The fluid/drain purge valve must be flushed to prevent material hardening in the fluid/drain purge valve. If that is not sufficient, remove, disassemble, and clean the valve then reinstall.

- Flush if the materials in the system are about to reach their cure time.
 - Flush anytime the flow rate starts to decrease as this is a sign that material is starting to thicken and cure.
 - Always flush the system at least twice, draining all water between flushes then replacing with clean water.
1. With the pump stopped, turn hydraulic pressure control (S) counterclockwise to lowest pressure.

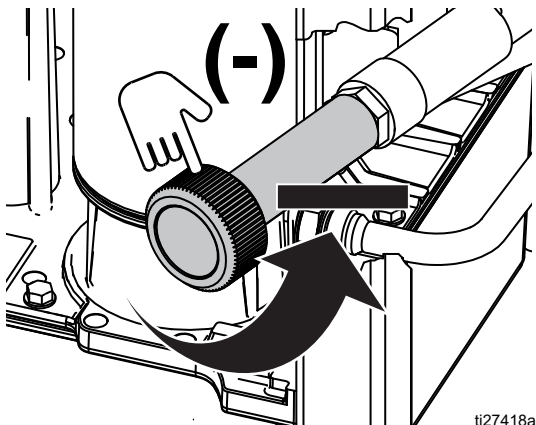

ti27418a

2. Remove applicator tip and retainer.

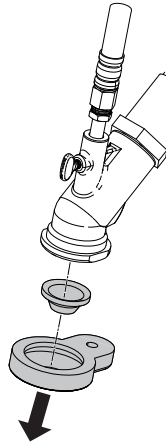

3. Place applicator outlet in a waste container. The waste container must be large enough to hold all dispensed material.

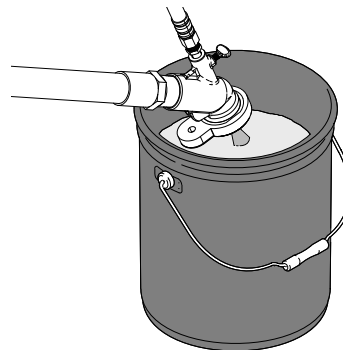

ti21632a

4. Turn hydraulic switch (BB) ON, and pump control switch (AA) to ON.
5. Increase pressure by turning the hydraulic pressure control (S) clockwise until a steady stream of material flows from the applicator.
6. When the material level in the hopper is within a few inches of the material inlet at the bottom:
 - a. Scrape the material down the sides of the hopper.
 - b. Fill the hopper with water as the material runs out and continues dispensing.

Flush

7. Keep the hopper filled with water while dispensing.

NOTE: Be prepared to decrease pressure using the hydraulic pressure control (S) when the material exiting the hose changes to water. Cycle rate can increase as material is flushed from the hose.

8. When water begins to exit the applicator outlet, switch the pump control switch (AA) to OFF to stop dispensing.

9. Place applicator in the system hopper with the outlet pointing down to enable circulation of water.

10. Circulate clean water:

- a. Fill the system hopper with clean water.
- b. Use a scrub brush to scrub the walls of the hopper.
- c. Switch the pump control switch (AA) to ON to begin circulating water.
- d. While pumping, turn the hydraulic pressure control (S) knob to a lower setting and open the fluid drain/purge valve (C). Allow the water to flush out any materials to prevent material hardening in the valve. Once the water appears clean, close the fluid drain/purge valve (C).
- e. Turn the pump control switch (AA) to OFF.
- f. Place applicator outlet in a waste container.
- g. Turn the pump control switch (AA) to ON to dispense into waste container.
- h. Dispense into waste container until hopper is almost empty, then turn the pump control switch (AA) to OFF.
- i. Repeat this entire "Circulate clean water" step one more time to ensure system is thoroughly flushed.

11. Remove the remaining material with a hose clean-out ball (see **Replacement Parts and Accessories**, page 49 for a list of available clean-out balls and the appropriate hose sizes to use them on):

- a. Remove the applicator from the end of the hose and place the hose outlet back in the waste container.
- b. Remove the hose inlet from the fluid outlet (B) and place a hose clean-out ball within the hose inlet. The ball must be wetted with water before inserting.
- c. Reattach the hose to the fluid outlet (B) and switch the pump control switch (AA) to ON to resume flushing the hose. Make sure the hopper is sufficiently full of water to keep pushing the ball out.
- d. The hose clean-out ball will be pushed out of the hose after several minutes. Once the ball is pushed through the hose, switch the pump control switch (AA) to OFF and repeat the entire process listed in step 11 one additional time to ensure the system is thoroughly flushed.

NOTE: Always use the appropriately sized clean-out ball for the hose size being flushed/cleaned.

NOTICE

Material left on the throat seal can dry out and damage the seal. Always stop the pump (park the pump) at the bottom of the stroke to avoid damage to the throat seal.

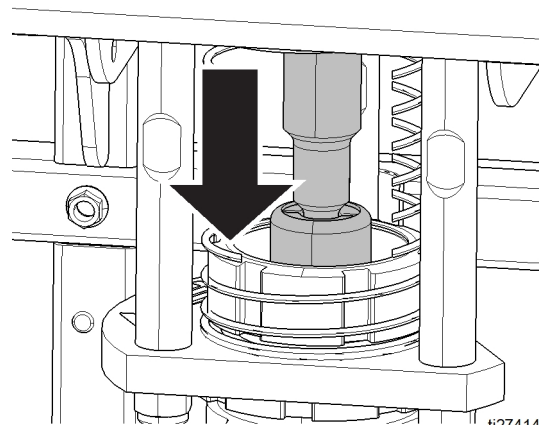

12. Turn compressed air on to blow out material that may have back-flowed into the air lines while flushing (this will prevent air line pack out).
13. After performing step 11 at least twice, drain remaining water from system:
 - a. Place drain pan beneath pump lower and hopper elbow (G).
 - b. Remove the material hose prior to pivoting pump.
 - c. Detach pump from hopper and remove hopper elbow (G) between hopper and pump lower.

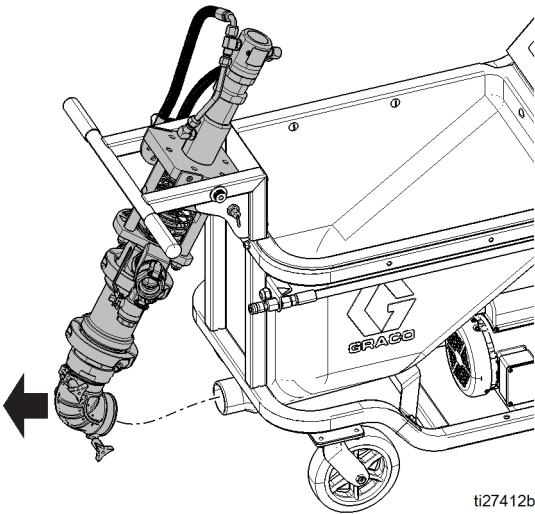

- d. Use a screwdriver to lift the pump lower inlet ball. This will drain the remaining material from the pump lower. When the pump stops draining, release the pump lower inlet ball.

- e. Install hopper elbow (G) and attach pump to hopper.

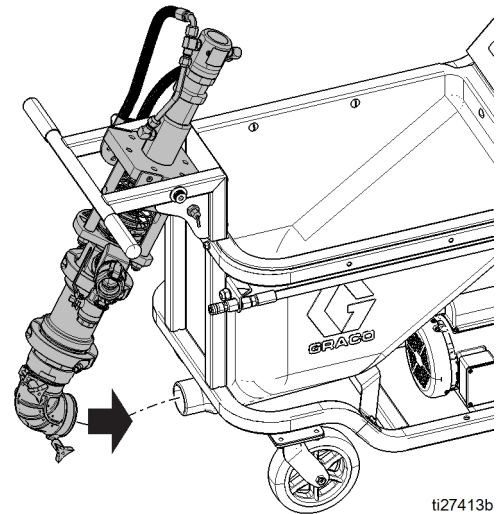

- f. Starting at the pump, raise the hose bundle above your head and slowly move towards the applicator. As you move towards the applicator, the remaining waster in the hose will drain from the applicator into the bucket.
14. Dispose of all waste material in accordance with local rules and regulations. See manufacturer's SDSs for additional information.

Mix the Material

Always flush the pump, hose, and applicator with water before loading material.

Always follow the material manufacturer's instructions for the material being sprayed. Material must be thoroughly mixed to a smooth consistency before loading it in the hopper.

Managing Material After Mixing:

- Pay close attention to the work life of the material being used.
- Only mix the material kits as needed. Do not let mixed material sit longer than necessary.
- Scrape material down the sides of the hopper as the hopper material level lowers. Do not let older material cure on the walls.
- Occasionally, do not refill the hopper until it is almost empty. This ensures all material in hopper is used while fresh.

Prime with Material



NOTICE

To prevent material curing in system, never load material into a dry system. Loading material into a dry system will cause the material to stick to internal components and cure causing damage and requiring replacement of those parts.

The applicator nozzle or tip must be removed during priming. Always push out any remaining water into a waste container before circulating material. Always circulate clean material back into the hopper for a few minutes before beginning to spray.

1. Mix the material. See **Mix the Material**, page 20.

2. Turn hydraulic pressure control (S) counterclockwise to lowest pressure.

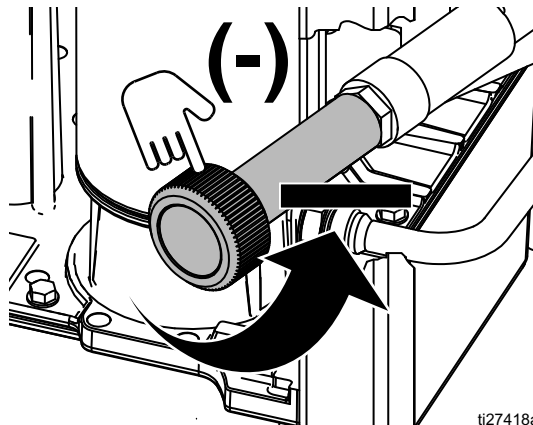

3. Remove applicator from hose outlet.
4. Fill the clean hopper with material to be sprayed.
5. Place hose outlet in a 5 gallon waste container or container of appropriate size.

NOTICE

To prevent damage to pump seals caused by cavitation, run the pump slowly until the system is primed.

6. Turn main power disconnect (DD) ON.

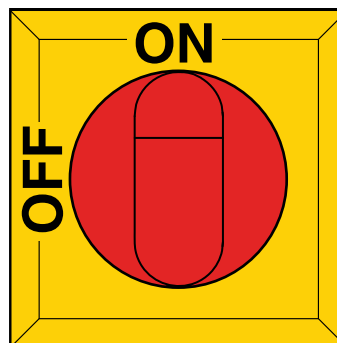

7. Set the hydraulic switch (BB) to ON, and the pump control switch (AA) to ON.
8. Increase pressure by turning the hydraulic pressure control (S) clockwise until a steady stream of mixed material flows from the hose outlet.
9. To stop dispensing, switch the pump control switch (AA) to OFF.

10. Remove the tip from the applicator and install onto the hose outlet. Switch the pump control switch (AA) to ON and pump until material flows from the applicator.
11. Turn the pump control switch (AA) OFF to stop dispensing.

12. Install a tip onto applicator (see Applicator manual 3A3244). The system is now primed and ready to spray.

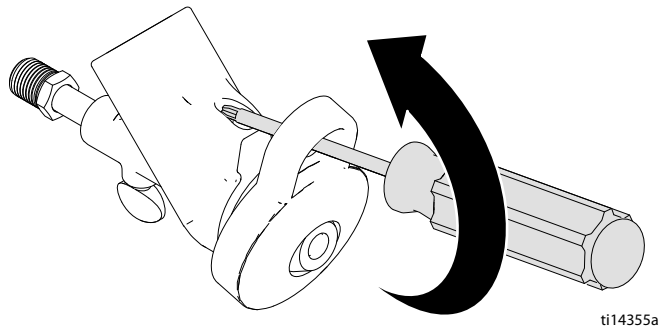

ti14355a

Spray

Prevent Pack-out

to avoid “packing out” the pump or hose:

- Use the lowest pressure and largest nozzle size that provides an acceptable spray pattern. This will also result in seals and wear parts lasting much longer.
- Do not use any more fluid hose than is necessary.
- Use an applicator with a rubber tip retainer that will blow off if it plugs.

Before Starting or Stopping Material Flow

- Always have the atomizing air turned on at the applicator (see Applicator manual 3A3244) before and after spraying.

NOTE: If ball valve kit (17J703) has been installed, do NOT use the valve to stall the pump. The pump must be stopped first before the ball valve can be closed.

Before Starting Material Flow

1. Always open and adjust the air ball valve (CB) first.
2. Next, switch the pump control switch (AA) to ON.

Before Stopping Material Flow

1. Always switch the pump control switch (AA) to OFF first.
2. Turn off the air ball valve (CB) last.

Sprayer Performance

NOTE: The check valve (46) helps to improve pump performance with highly compressible gypsum based materials. For high density, Portland cement based materials, the check valve (46) can be replaced with 1-1/2 NPT Nipple Fitting (121441) to reduce pressure drop and improve performance.

Spraying



1. **Mix the Material**, page 20.
2. **Prime with Material**, page 20.

NOTICE

- Do not allow pump to run without material in the hopper. It can cause damage to the pump seals.
- To prevent material curing in system, never load material into a dry system. Always prime system with water first. Loading material into a dry system will cause the material to stick to internal components and cure causing damage and requiring replacement of those parts.
- Failure to flush prior to material curing in the system will result in damage to system and may require replacement of all system parts in contact with the material.

3. Open air ball valve (CB) on spray pole applicator. See Applicator manual 3A3244.
4. Turn hydraulic pressure control (S) counterclockwise to lowest pressure.

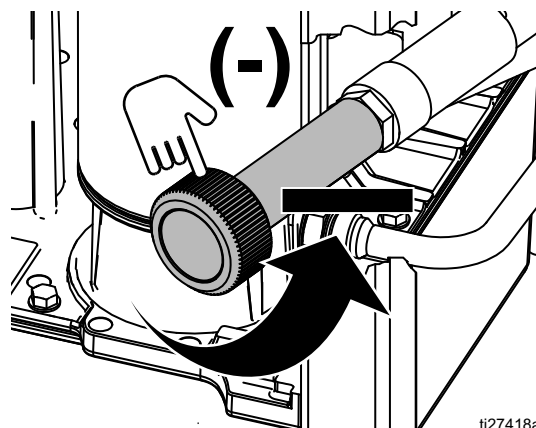

- Verify that the main power disconnect (DD) is ON.

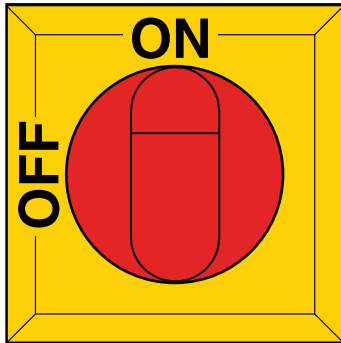

ti27407a

- Turn the pump control switch (AA) to ON to cycle the pump, or turn the switch to REMOTE and set the remote switch to ON to cycle.

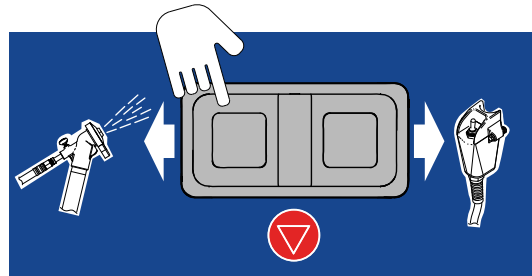

ti27410a

- Turn compressor switch (CC) ON to start the compressor.

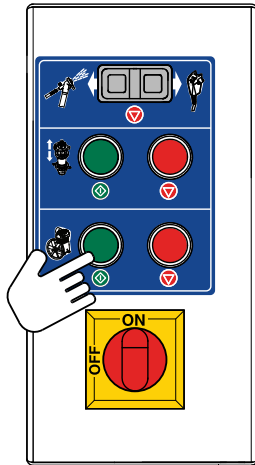

ti27408a

- Turn the hydraulic pressure control (S) clockwise until desired flow is reached. Turn counterclockwise to decrease flow.

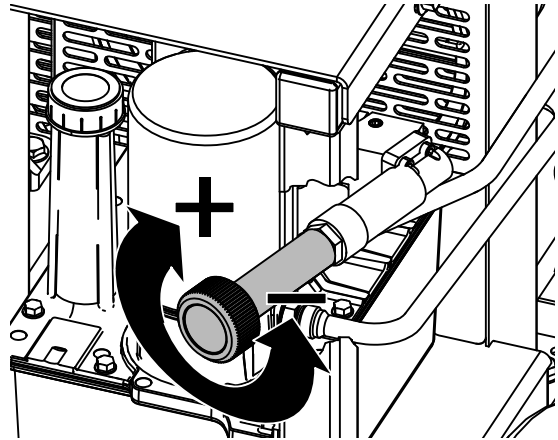

ti27417a

- Turn hydraulic switch (BB) ON, to start the hydraulic pump.

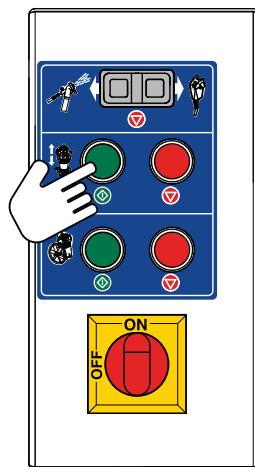

ti27409a

- If the system is approaching its cure time or the system will be idle for enough time for material to begin curing in the system, flush the system. See **Flush**, page 17.

Spray Adjustments (Pole Spray Applicator)

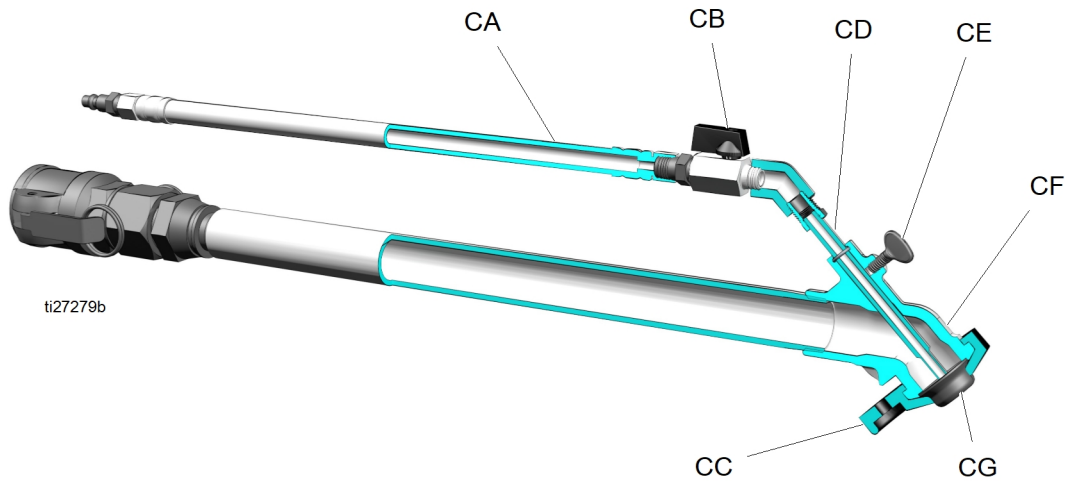

Key:

- CA Air Assist Air Line
- CB Air Assist Shutoff Ball Valve
- CC Rubber Tip Retainer
- CD Air Needle (adjustable position)
- CE Air Needle Retaining Screw
- CF Fluid Housing
- CG Tip (Nozzle)

General Adjustments

The spray pattern can be adjusted by changing:

- Tip (CG) size
- Air flow, use air ball valve (CB)
- Air Needle (CD) position

Adjust Air Flow: Adjust the air assist shutoff ball valve (CB) for the minimum air flow necessary for a good pattern. Air bleeds from the applicator nozzle (CG) whenever the applicator air assist shutoff ball valve (CB) is open. Close the valve to stop the air flow, if desired. Otherwise, the air valve can stay open during priming. Air must be on prior to fluid flow.

Adjust Air Needle (CD) position: Make sure the air needle (CD) is slightly behind the tip (CG). The general rule for setting the air needle position is that the air needle should be the same distance back from the tip as the size of the orifice. For example, if you have a 1/2 in. tip installed, the air needle should be approximately 1/2 in. behind the tip.

NOTE: Installing the needle too far forward can restrict or completely block material flow. This can result in the retainer (CC) blowing off. Installing the needle too far back can raise the pressure behind the fluid enough to blow the retainer (CC) off and can cause dripping.

Air Flow Valve Adjustment

To decrease air flow, turn the valve knob clockwise.

To increase air flow, turn valve knob counterclockwise.

Check material and thin as needed to maintain the proper consistency. The material may thicken as it sits and could slow down application or affect the spray pattern.

Flush and dry applicator thoroughly at the end of each use. Tips and retainers must be cleaned by hand.

Material Flow Adjustments

For a lighter spray pattern, adjust the air needle closer to the fluid nozzle and/or reduce the fluid flow.

For a heavier spray pattern, adjust the air needle farther back from the fluid tip and/or increase the fluid flow.

NOTE: Withdrawing the needle too far can force air pressure back into the fluid hose, which can slow material down.

Spray Techniques

1. Test the spray pattern on cardboard. Hold the applicator 6-18 in. (150-450 mm) from the surface. Use this spraying distance for most applications.
2. Adjust fluid flow until material flow is adequate.
3. Adjust the applicator air ball valve to achieve a uniform round spray pattern.
4. Consider the size of aggregate in the material and the coarseness of the spray pattern. Larger nozzles allow heavier patterns.
5. Overlap each stroke 50%. A circular overlapping pattern may give the best results.

When spraying small confined areas use the air ball valve and air needle position to make fine adjustments without adjusting the pump.

High pressures may cause excessive wear on the fluid pump. Select a fluid large enough to spray at low pressure. Some material will pack-out at higher pressures.

Installing Nozzle Retaining Cap

1. Place the rubber tip retainer (CC) over top lip of applicator housing.
2. Insert a screwdriver through the hole in the tab of the rubber tip retainer.
3. Push the screwdriver head against the notch on the applicator tip and pry the rubber tip retainer over the tip (CG), spray shield (if one is being used), and over the lip until it snaps into place.

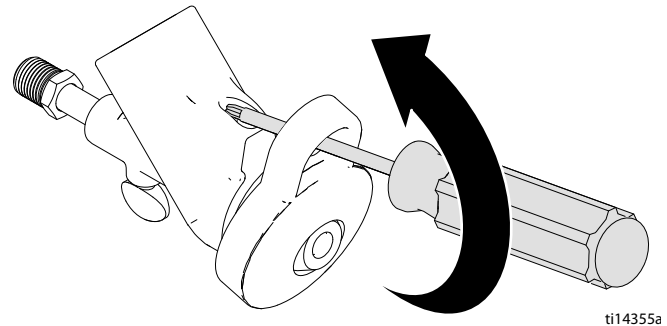

ti14355a

FIG. 1

4. Turn the rubber retainer back and forth to be sure it is fully seated.

NOTE: The rubber gasket in the cam and groove inlet fitting and the rubber nozzle retainer should be hand cleaned and dried after each use.

Pressure Relief Procedure



Follow the Pressure Relief Procedure whenever you see this symbol.



This equipment stays pressurized until pressure is manually relieved. To help prevent serious injury from pressurized fluid, such as splashing fluid and moving parts, follow the Pressure Relief Procedure when you stop spraying and before cleaning, checking, or servicing the equipment.

1. Turn hydraulic pressure control (S) counterclockwise to lowest pressure.

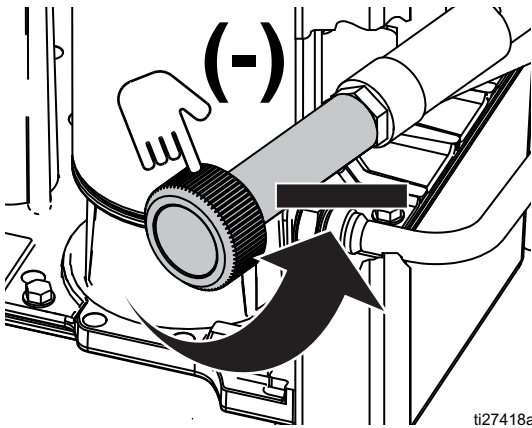

2. Turn main power disconnect (DD) off.

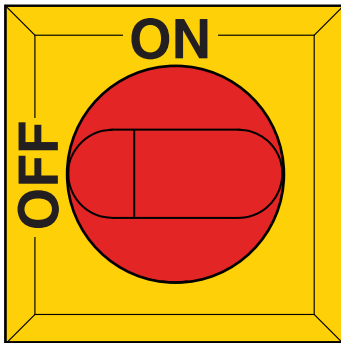

3. Remove the applicator tip and tip retainer, and hold applicator firmly against a pail.

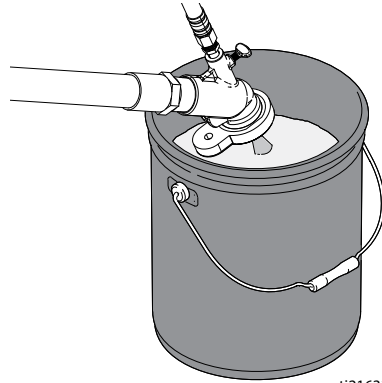

To avoid injury from splashing fluid, never open an applicator or hose fitting while there is pressure in the fluid line.				

4. If the applicator ball valve kit (17J703) has been installed, open the ball valve.
5. If you suspect the applicator tip or hose is completely clogged, or the pressure has not been fully relieved after following the previous steps, slowly open the fluid drain/purge valve (C) at the pump outlet and drain material into a waste pail.
6. If there is still pressure trapped in the line, very slowly loosen the threaded swivel fitting at the pump outlet while keeping it covered until the pressure is relieved.

Shutdown



NOTICE
To prevent rust, never leave water or water-based fluid in pump overnight.

To shut down the sprayer, flush the system. See **Flush**, page 17.

Turn main power disconnect (DD) OFF.

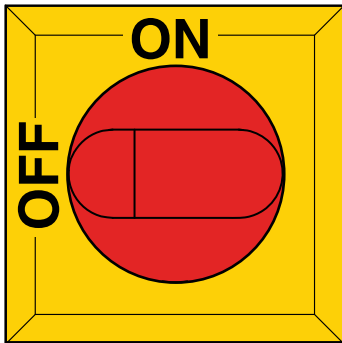

ti27415a

Corrosion Protection

NOTICE
To prevent rust, never leave water or water-based fluid in pump overnight.

NOTICE
Material left on the throat seal can dry out and damage the seal. Always stop the pump at the bottom of the stroke to avoid damage to the throat seal.

Always flush the pump before the material dries on the displacement rod. For longer periods of time where the pump is not in use, pump oil through the pump lower, then relieve the pressure. Leave oil in the pump to protect the parts from corrosion.

Lifting Instructions

NOTE: When lifting the unit, use a forklift and always lift from the rear of the system. The center of mass in the F680e is in the middle of the sprayer. With shorter forklifts or when driving the forklift over rough terrain while carrying the F680e, install the forklift stabilization kit 24Y479. These support brackets will hold the F680e onto the forks and prevent the sprayer from falling, tipping, or bouncing off the forks. The forklift stabilization kit (24Y479) is not included in the base models.

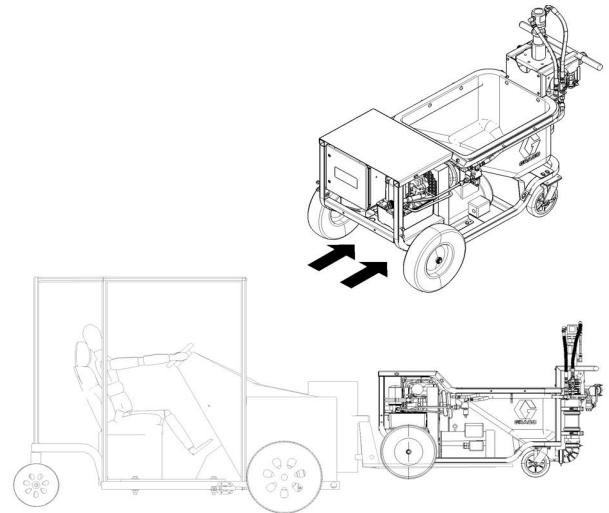

i26877b

Maintenance

Daily Maintenance



1. Flush the system. See **Flush**, page 17.
2. Relieve pressure. See **Pressure Relief Procedure**, page 26.
3. Clean hopper with a scrub pad. It is recommended that you clean the outside of the sprayer using a cloth and water.
4. Check hoses, tubes, and couplings. Tighten all fluid connections before each use.
5. Check and replace cam-lock gaskets as needed.

Preventative Maintenance

The operating conditions of your particular system determined how often maintenance is required. Establish a preventative maintenance schedule by recording when and what kind of maintenance is needed, and then determine a regular schedule for checking your system.

DAILY: Check hydraulic oil level and fill as necessary.

DAILY: Check compressor oil level and fill as necessary. Compressor oil should be replaced after 50 hours (break-in) and every 200 hours after initial oil change. If the compressor oil is dark black and shows sediment before the 200 hour time period is complete, replace the oil.

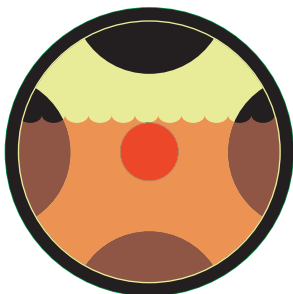

NOTE: If the red dot on the compressor sight glass is visible, add oil.

DAILY: Check hose for wear and damage.

DAILY: Inspect hydraulic and fluid lines for leaks.

DAILY: Check fluid drain/purge valve (C) for proper operation. Clean/flush the valve if necessary.

DAILY: Check level of Throat Seal Liquid (TSL) in displacement pump packing nut (D). Fill nut, if necessary. Keep TSL in nut to help prevent material buildup on piston rod and premature wear of packings and pump corrosion.

WEEKLY: Remove the compressor air filter cover and clean element. Replace the element if necessary.

WEEKLY: Check the hydraulic fluid level weekly using a dipstick. The fluid level must be between the marks on the dipstick. Refill as required with approved hydraulic fluid (see **Technical Specifications**, page 54). If the fluid is dark in color, change the fluid and filter. Replace break-in oil in a new unit after the first 250 hours of use or within 3 months, whichever comes first. See the table below for recommended frequency of oil change.

Ambient Temperature	Recommended Frequency
0° to 90° F (-17° to 32° C)	1000 hours or 12 months, whichever comes first
90° F and above (32° C and above)	500 hours or 6 months, whichever comes first

NOTE: If operating in an unusually dusty environment, check the filter daily and replace if necessary.

MONTHLY: Clean the pre-filter and muffler on the air compressor air relief valve. Replace the air relief valve (part 17H606) and muffler (part 120206) if necessary.

SEMI-ANNUALLY: Check belt wear. Replace if necessary.

Repair

Replace Pump Lower



Perform the procedure below to replace the entire pump lower with a new or different pump lower. Before following the pump lower replacement procedure, perform the **Pressure Relief Procedure**, page 26 and disconnect the material hose.

1. Remove outlet fittings (OF) from the pump lower outlet.
2. Loosen the hopper elbow clamps (V), retract the spring-loaded locking pin (Z), and slowly swing the pump up until the spring loaded locking pin clicks into place.
3. Remove the hopper elbow (26) from the pump lower (908).
4. Lift up the pump spring around guard (906) and disconnect the hydraulic displacement rod by removing clip (916) and disassembling the coupler cover (917) and assembly coupling (918).
5. Unthread all three lock nuts (907) from the tie rods and remove the pump lower (908). The pump lower should now be separated from all other parts. Replace the pump lower and reinstall it into the unit. If the pump components need replacing, see **Replace Pump Components**, page 31.

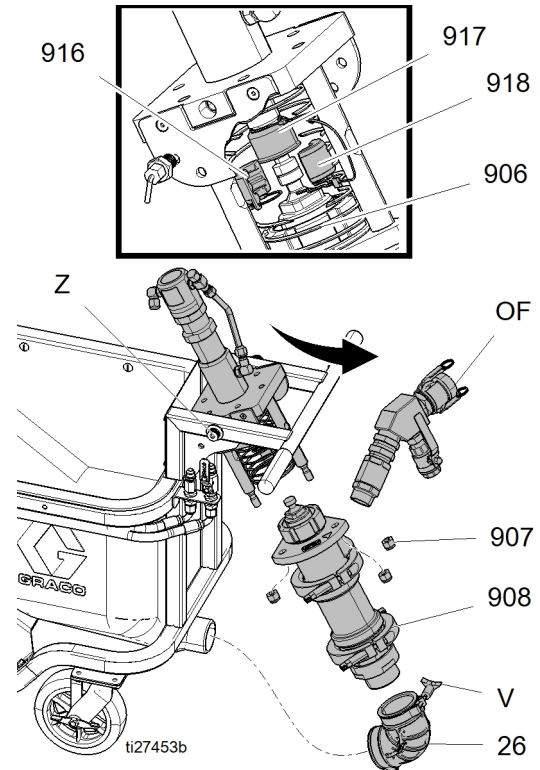

NOTICE

The pump lower (908) is heavy. Dropping the pump can cause damage to the equipment. Make sure you have a secure hold on the pump lower when removing the last lock nut (907).

NOTE: When reinstalling the pump lower, tighten the jam nut (806) when the top surface of the mounting cylinder plate (809) is flush to within +/- .060 in. of the top surface of the outlet housing (805). The 1-1/2 NPT hole in the outlet housing (805) should be in line with the flats on the mounting cylinder plate (809).

Partial Pump Lower Disassembly



Perform the procedure below to clean or replace a portion of the pump lower without removing the entire pump lower from the unit. Before following the partial pump lower disassembly procedure, perform the **Pressure Relief Procedure**, page 26 and disconnect the material hose.

1. Loosen the hopper elbow clamps (V), retract the spring loaded locking pin (Z), and slowly swing the pump up until the spring loaded locking pin clicks into place.
2. Remove the hopper elbow (26) from the pump lower.
3. Remove the inlet housing by unthreading the extension nuts (831, 832) on the bottom pump clamps (803).
4. Remove the pump cylinder by unthreading the extension nuts (831, 832) on the top pump clamps (803) and sliding the cylinder (804) off the piston rod packing cup.

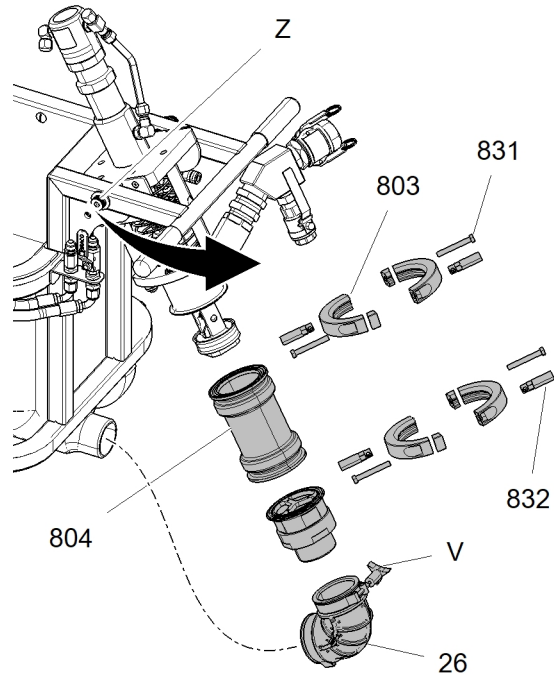

ti27454b

Replace Pump Components

Remove the pump lower (908 - 24Y513) before replacing any pump components.

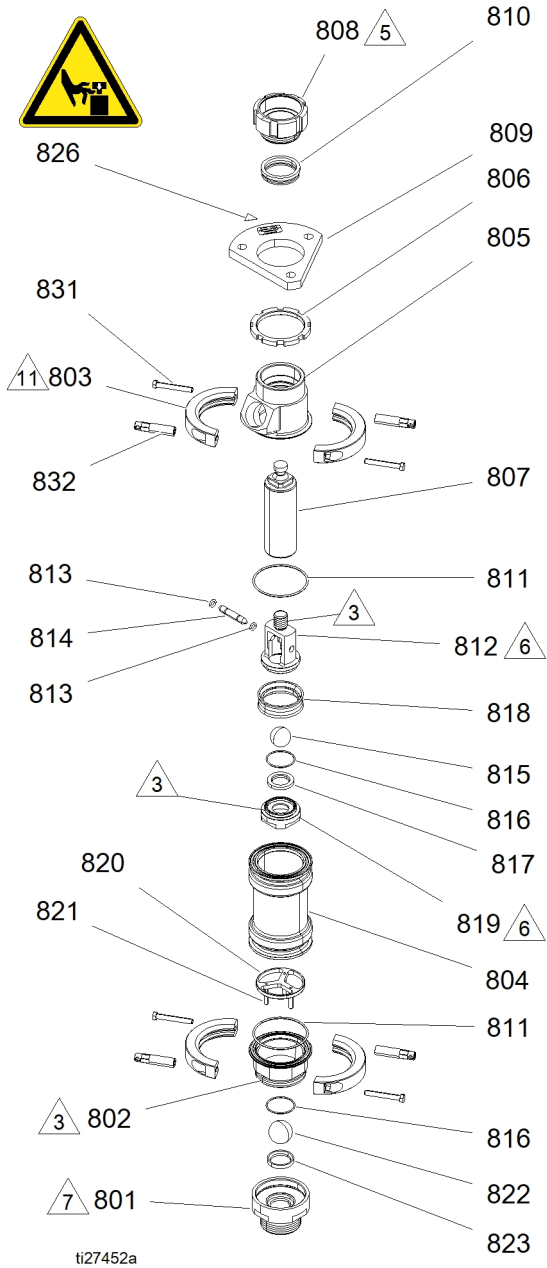

Repair

Ref.	Part	Description	Qty.	Ref.	Part	Description	Qty.
801	17G221	HOUSING, inlet	1	821	†	PIN, ball, stop	3
802	17G226	HOUSING, inlet, ball guide	1	822	112420	BALL, sst, 1590	1
803	†	CLAMP, 4 in., 100 psi	2	823	†	SEA, valve, lapped, tungsten carbide	1
804	16U798	CYLINDER, pump	1	826▲	15H108	LABEL, warning, pinch, point	1
805	17G220	HOUSING, outlet, 680	1	831	106212	SCREW, cap, hex hd	4
806	16U977	NUT, jam	1	832	†	NUT, extension	4
807	16U804	ROD, displacement	1				
808	16U805	NUT, packing	1				
809	16U976	PLATE, mounting, cylinder	1				
810	†	BEARING, seal	1				
811	†	PACKING, o-ring	2				
812	17G224	HOLDER, valve, piston, 680	1				
813	†	PACKING, o-ring	2				
814	16U801	STOP, upper ball	1				
815	108001	BALL, metallic	1				
816	†	O-RING, 50 mm x 2.5 mm	2				
817	†	SEAT, valve, tungsten carbide	1				
818	†	PACKING, cup	1				
819	17G223	VALVE, piston, 680	1				
820	†	STOP, ball, inlet, 680	1				

† See **List of Kits** below.

▲ Replacement Danger and Warning labels are available at no cost.

△₂ Apply grease lubricant to threads, o-rings, and seals.

△₃ Apply serviceable thread locker to threads.

△₅ Torque to 30 +/- 5 ft-lb (40 +/- 6.7 N-m).

△₆ Torque to 100 +/- 10 ft-lb (135 +/- 13.5 N-m).

△₇ Torque to 200 +/- 10 ft-lb (271 +/- 13.5 N-m).

△₁₁ Position the pump housing outlet (805) as shown in relation to the position of the pump clamps (803) and extension nuts (832).

List of Kits

Kit	Description	Ref. # (Qty.)
17H242	Repair pump rebuild kit	810 (1), 818 (1), 813 (2), 816 (2), 815 (1), 822 (1), 811 (2)
17G456	Pump lower clamp kit	832 (2), 831 (2), 803 (1)
16W490	10 pack o-ring repair kit	811 (10)
24Y513	F680e complete assembled pump lower	All parts listed in Replace Pump Components , page 31
16W510	Inlet seat and o-ring repair kit	823 (1), 816 (1)
17H191	Piston seat and o-ring repair kit	816 (1), 817 (1)
16W491	3 pack piston packing cup repair kit	818 (3)
16W492	3 pack throat seal repair kit	810 (3)
17K490	Ball inlet stop kit	820 (1), 821 (3)

Replace Check Valve (909 - 17H194)

Remove the check valve before replacing any check valve components.

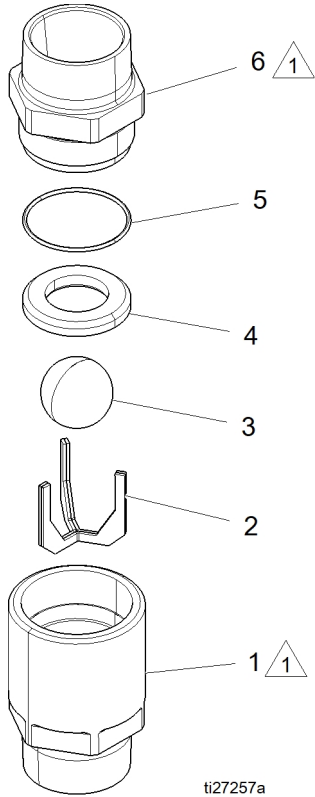

Ref.	Part	Description	Qty.
1	†	HOUSING, check valve, outlet	1
2	17J712	RETAINER, ball	1
3	102973	BALL, metallic	1
4	†	SEAT	1
5	113082	Packing, o-ring	1
6	†	Retainer, check valve, seat, outlet	1

† See List of Kits table below.

 Torque to 70-85 ft-lb (95-115 N·m).

List of Kits

Kit	Description	Kit Contents: Ref. # (Qty.)
17H192	Check valve seat and o-ring repair kit	4 (1), 5 (1)
113082	Packing, o-ring, (check valve packing o-ring)	5 (10)
17H194	Complete 1.5 in. outlet check valve	1 (1), 2 (3), 3 (1), 4 (1), 5 (1), 6 (1)

Hydraulic Pump and Compressor Belt Repair



Perform the procedure below to replace either the hydraulic pump belt or compressor belt. Before following the belt repair procedure, see **Shutdown**, page 27.

Remove the Compressor Belt Guards

1. Remove the washers (85), screws (86), and top cover (88).
2. Remove the two washers (92) and screws (91) holding the hydraulic pump guard (93) and compressor top guard (94) together.
3. Remove the washer (92) and screw (90) holding the compressor top guard (94) and compressor side guard (79) together, and then slide the compressor top guard up and out of the sprayer.
4. Remove the two screws (20) holding the compressor side guard (79) to the frame and slide guard out sideways.
5. Rotate the belt tension adjuster (23) in towards the sprayer, then remove and replace the air compressor belt (58).

Remove the Hydraulic Pump Belt Guards

1. Remove the washers (85), screws (86), and top cover (88).
2. Remove the two washers (92) and screws (91) holding the hydraulic pump guard (93) and compressor top guard (94) together.
3. Remove the two screws (20) holding the hydraulic pump guard (93) to the frame and slide the guard up and out of the sprayer.
4. Rotate the belt tension adjuster (23) in towards the sprayer, then remove and replace the hydraulic pump belt (27).

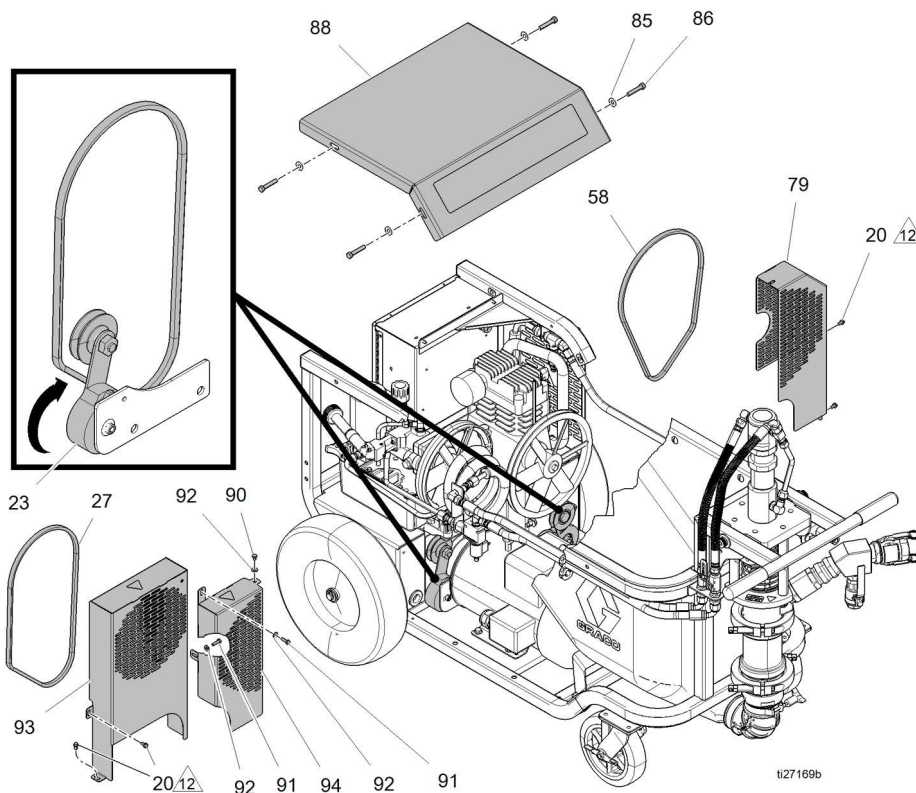

Parts

F680e Parts

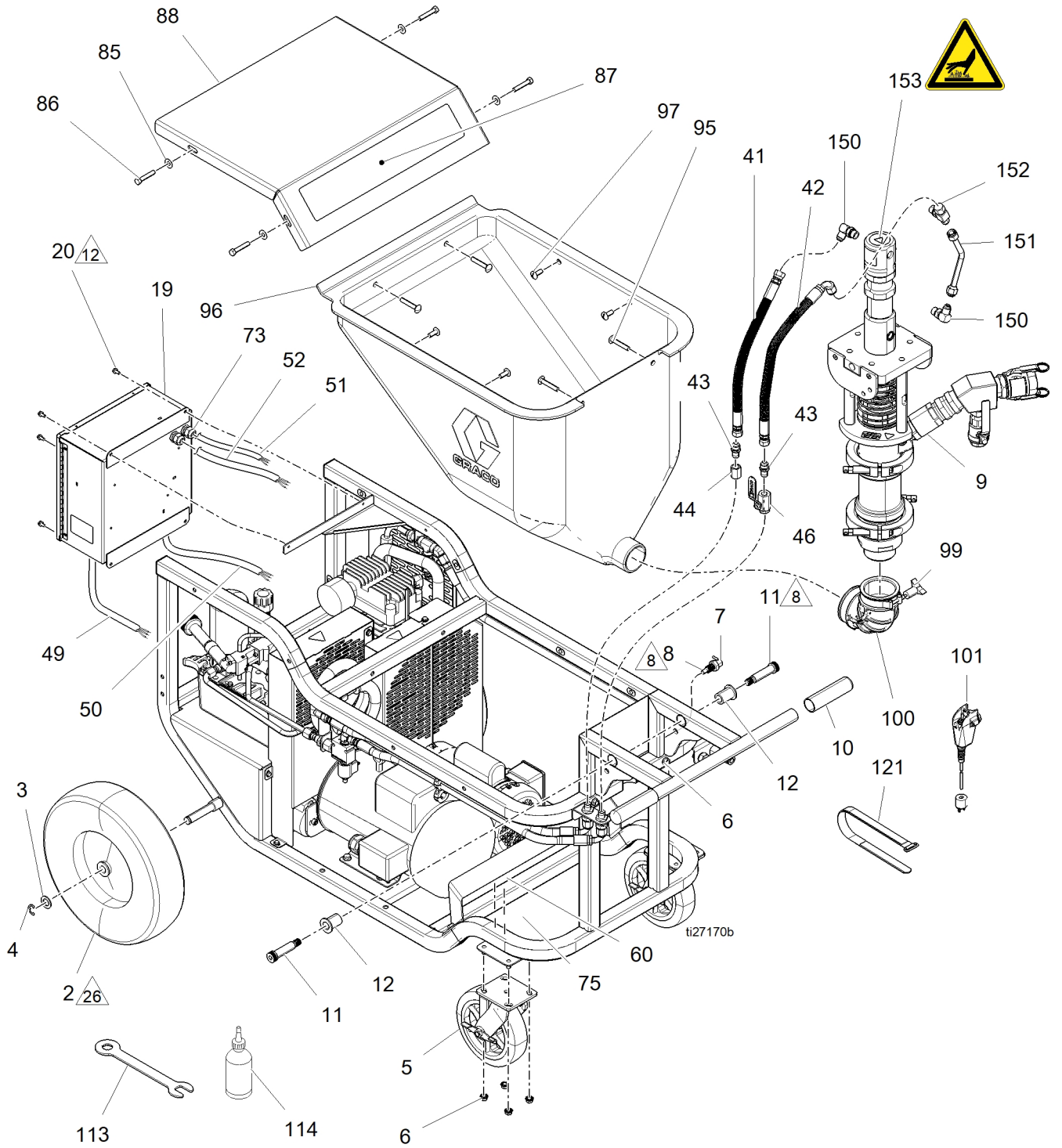



F680e Parts List

Ref.	Part	Description	Qty.	Ref.	Part	Description	Qty.
2	113362	WHEEL	2	75	17G250	BRACKET, hopper, painted	2
3	154628	WASHER	2	85		WASHER, 3/8 in. plain flat	4
4	113436	RING, retainer	2	86	111803	SCREW, cap, hex hd	4
5	17G235	CASTER, forged	2	87	†	LABEL, F680e	1
6	112958	NUT, hex, flanged	12	88	†	BRACKET, top, painted	1
7	17G245	NUT, 5/8-11, 3/8 thk	1	95	17G246	BOLT, carriage, 3/8-16 x 2.25 in.	4
8	17G537	PLUNGER, spring	1	96	25A315	TANK, 30 gal, 680e	1
9	24Y236	PUMP, hydraulic, 680	1	97	17G248	SCREW, truss, slotted, 3/8-16 x 1	4
10	119975	GRIP, vinyl, gray	2	99	17H196	CLAMP, hose, t-bolt	2
11	17G236	SCREW, shoulder, .75 in. diameter	2	100	17H193	BOOT, elbow, rubber, 3 in. ID	1
12	17G237	BEARING, bronze	2	101	17H197	SWITCH, remote, on/off	1
19		ENCLOSURE, elec, 230V, with compressor	1	113	127265	TOOL, wrench, ratchet, 5/8 in.	1
20	107257	SCREW, thd forming	19	114	206994	FLUID, TSL, 8 oz. bottle	1
41	17G257	HOSE, return, pivot	1	121	114271	STRAP, retaining	4
42	17G260	HOSE, supply, pivot	1	150	117607	FITTING, elbow, std thd	1
43	121311	FITTING, connector, npt x jic	2	151	17G219	TUBE, hydraulic, driver	1
44	162024	COUPLING	1	152	117609	FITTING, tee, branch, str thd	1
46	117441	VALVE, ball	1	153▲	15B063	LABEL, warning, hot surface	1
49	128553	HARNESS, motor, hydraulic, 680e	1				
50	128554	HARNESS, motor, compressor, 680e	1				
51	128555	HARNESS, remote, switch, 680e	1				
52	128556	HARNESS, solenoid, 680e	1				
60	111192	SCREW, cap, flange hd	12				
73	114421	BUSHING, strain relief	1				

† See **List of Kits** below.

▲ Replacement Danger and Warning labels are available at no cost.

 Apply serviceable thread locker to threads.

 Torque to 120 +/- 5 in-lb (13.5 +/- 0.5 N-m).

 Position wheel (2) with grease fitting on the outside.

List of Kits:

Kit	Description	Kit Contents: Ref. # (Qty.)
25A316	F680e top cover	87 (1), 88 (1)

F680e Parts (continued)

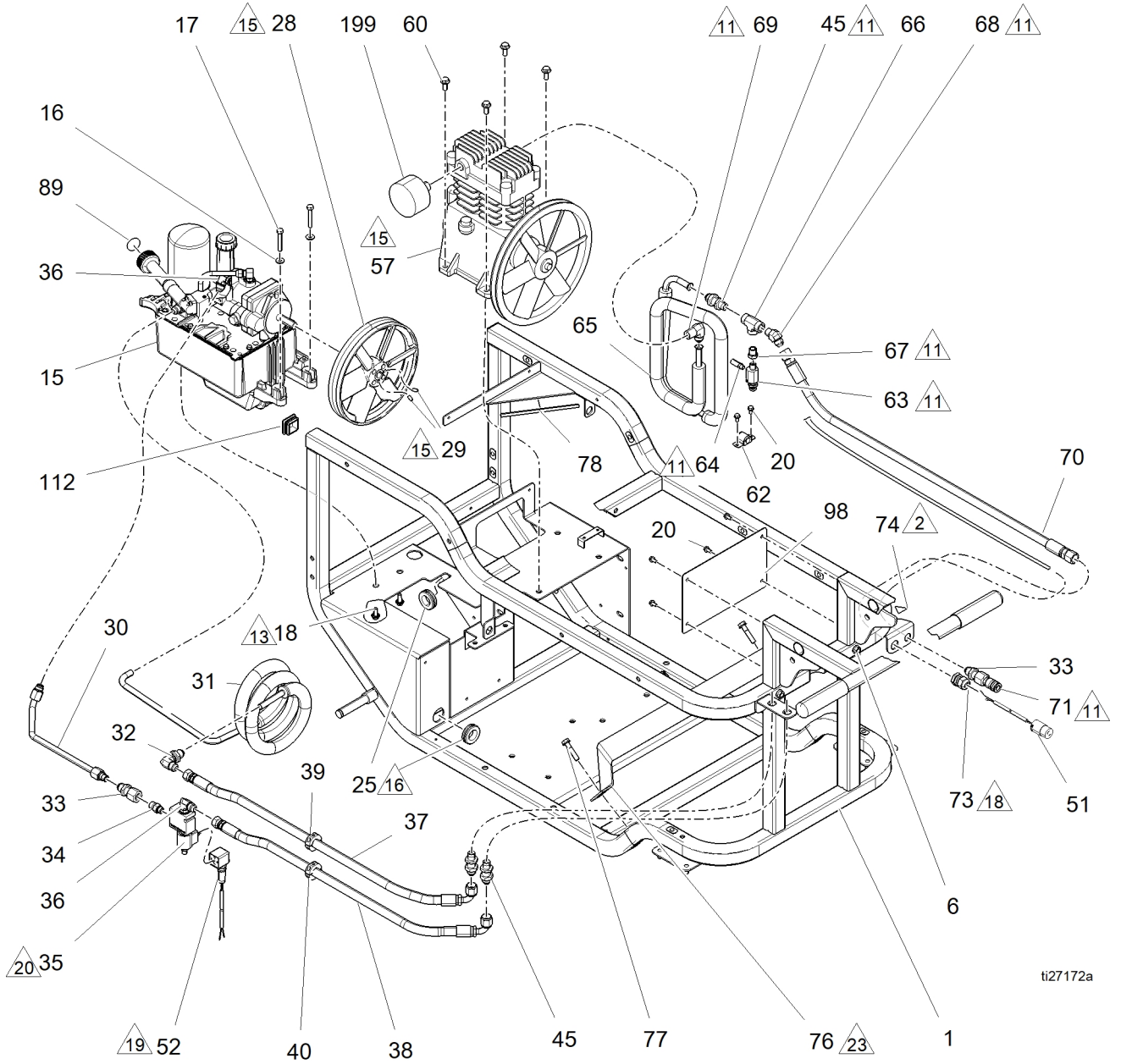

ti27172a

F680e Parts (continued)

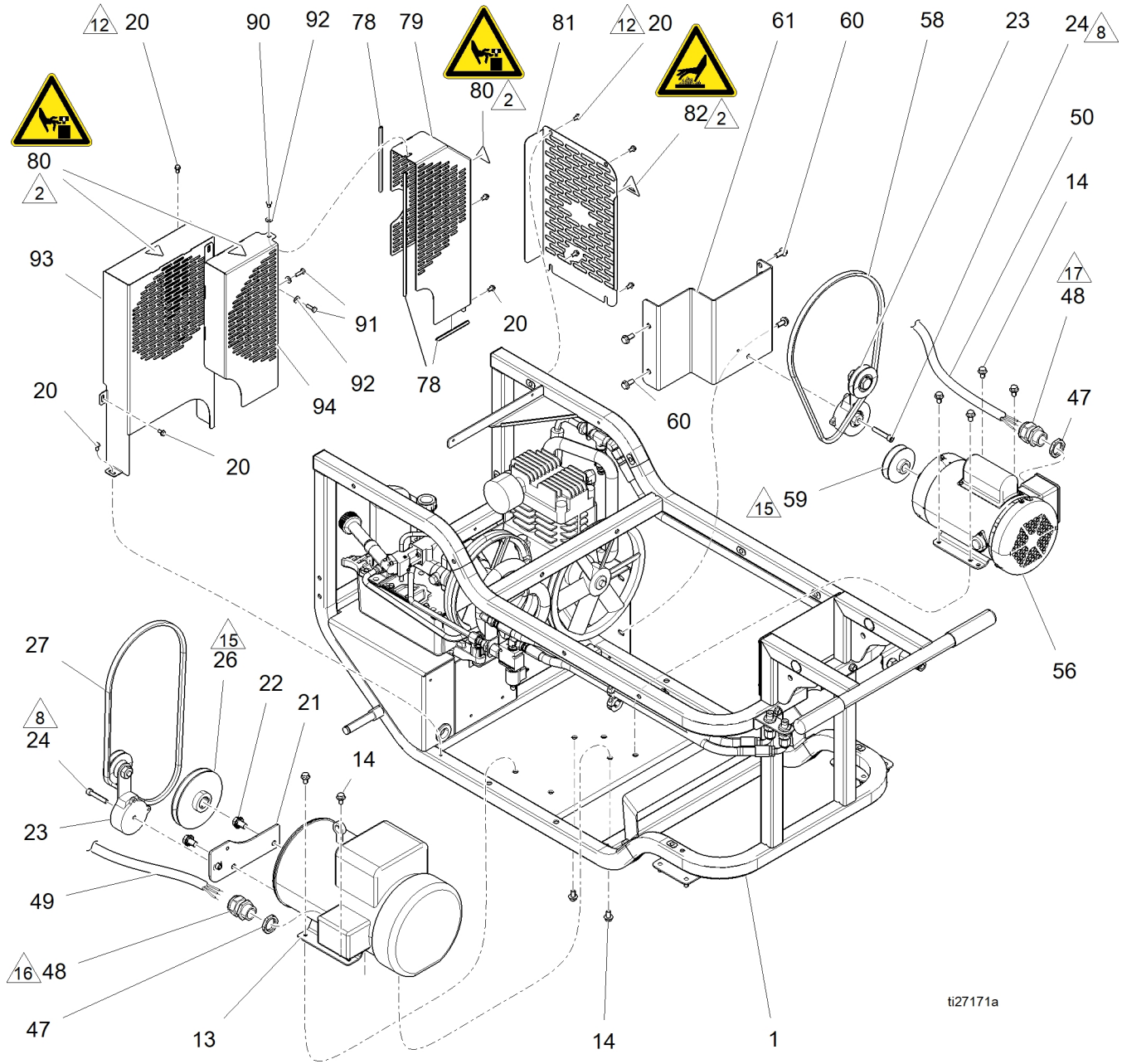

F680e Parts List (continued)

Ref.	Part	Description	Qty.	Ref.	Part	Description	Qty.
1		CART, 680e, weldment, painted	1	70	17G255	HOSE, air	1
6	112958	NUT, hex, retaining	12	71	17H021	FITTING, coupling, qd, 1/4 in.	1
13	17K004	MOTOR, 230 VAC, 4.0 hp	1	73	114421	BUSHING, strain relief	1
14	113802	SCREW, hex, hd, flanged 8	8	74▲	15K616	LABEL, caution	1
15	25A321	RESERVOIR, assembly, F680e	1	76	17K021	BRACKET, support, hopper, painted	1
16	100527	WASHER, plain	2	77	116780	SCREW, hex, hd, flanged	2
17	108481	SCREW, cap, hex hd	2	78	†	TRIM, edge, protection	2
18	117791	SCREW, cap, tri lobe	2	79	†	GUARD, belt, air, side	1
20	107257	SCREW, thd forming	19	80▲	16M768	LABEL, warning, ISO, pinch hazard	3
21	15H207	BRACKET, tensioner	1	81	†	GUARD, cooling, side, painted	1
22	111802	SCREW, cap, hex hd	2	82▲	16D646	LABEL, warning, ISO, hot surface	1
23	247853	ADJUSTER, belt, tensioner	2	89	15A464	LABEL, control	1
24	C19843	SCREW, cap, sockethead	2	90	100157	SCREW, cap, hex hd	1
25	17H048	GROMMET, 3/4 in. ID	2	91	15X227	SCREW, cap hex head	3
26	247845	PULLEY, drive, vee	1	92	110755	WASHER, plain	4
27	125834	BELT, tri-power, AX48	1	93	†	GUARD, belt, fluid	1
28	†	PULLEY, fan	1	94	†	GUARD, belt, air, top	1
29	†	SCREW, set, 1/4 x 1/2	2	98	17G254	COVER, splash, painted	1
30	17G258	TUBE, supply	1	199*	131366	KIT, air filter, F680	1
31	17K006	TUBE, cooling, hydraulic fluid, return	1				
32	17G704	FITTING, 90 degree elbow, 3/4-16 unf	1				
33	17G694	FITTING, straight, 3/4-16, nptf	2				
34	17G706	FITTING, straight, 3/8-18 npt	1				
35	17G261	SOLENOID, supply, switch	1				
36	118896	FITTING	1				
37	17G256	HOSE, return	1				
38	17G259	HOSE, supply	1				
39	17H028	CLAMP, hose, .75 ID stacking	1				
40	17H616	CLAMP, hose, .690 ID, stacking	1				
45	122401	ADAPTER, bulkhead, #8 JIC - #6 nptf	3				
47	†	NUT, bushing	2				
48	†	BUSHING, strain relief	2				
51	128555	HARNESS, remote switch, 680e	1				
52	128556	HARNESS, solenoid, 680e	1				
56	17K005	MOTOR, 230 VAC, 2.0 HP	1				
57	24N370	PUMP, compressor, air	1				
58	17G244	BELT, AX, air	1				
59	17G241	PULLEY, 2.6 in. pitch diameter	1				
60	111192	SCREW, cap, flange hd	12				
61		BRACKET, tensioner, air, painted	1				
62	128662	CLAMP, vibration damping	1				
63	17H606	VALVE, air, relief	1				
64	120206	MUFFLER, 1/8 npt	1				
65	17K007	TUBE, cooling, compressor	1				
66	114526	FITTING, tee, pipe	1				
67	118758	FITTING, adapter	1				
68	122533	FITTING, 45 degree elbow, #8 JIC x 3/8	1				
69	121486	FITTING, elbow, male, 1/2 JIC x 1/2 npt	1				

† See **List of Kits** on the following page.

* Replacement pleated filter elements are available for steel, twist lock-style filters (131367). Purchase an upgraded filter (131366) for plastic wingnut-style filters.

▲ Replacement Danger and Warning labels are available at no cost.

 Locate approximately as shown.

 Apply serviceable thread locker to threads.

 Add PTFE thread seal tape to pneumatic fittings.

 Torque to 120+/- 5 in-lb (13.5 +/- 0.5 N·m).

 Torque to 177.5 +/- 2.5 in-lb (20 +/- 0.28 N·m).

 Align pulleys to belt tension adjuster (23) before installing the corresponding screws. Apply serviceable thread locker to the set screws.

 Feed motor cable (49) through hole.

 Feed motor cable (50) through hole.

 Feed remote switch cable (51) through hole.

 Feed solenoid cable (52) through hole.

 Position cable plug toward the inside of the unit.

List of Kits:

Kit	Description	Ref. # (Qty.)
25A312	Hydraulic pump pulley and set screws	28 (1), 29 (2)
25A314	Air compressor side belt guard	78 (2), 79 (1), 80 (1)
25A318	Hydraulic pump belt guard	93 (1), 80 (1)
25A319	Air compressor top belt guard	94 (1), 80 (1)
25A321	F680e complete hydraulic pump and reservoir assembly	15 (1)
25A313	Bushing with nut	47 (1), 48 (1)
25A317	Cooling Side guard	81 (1), 82 (1)

Enclosure Parts

(Electrical enclosure for 24Y500 shown below)

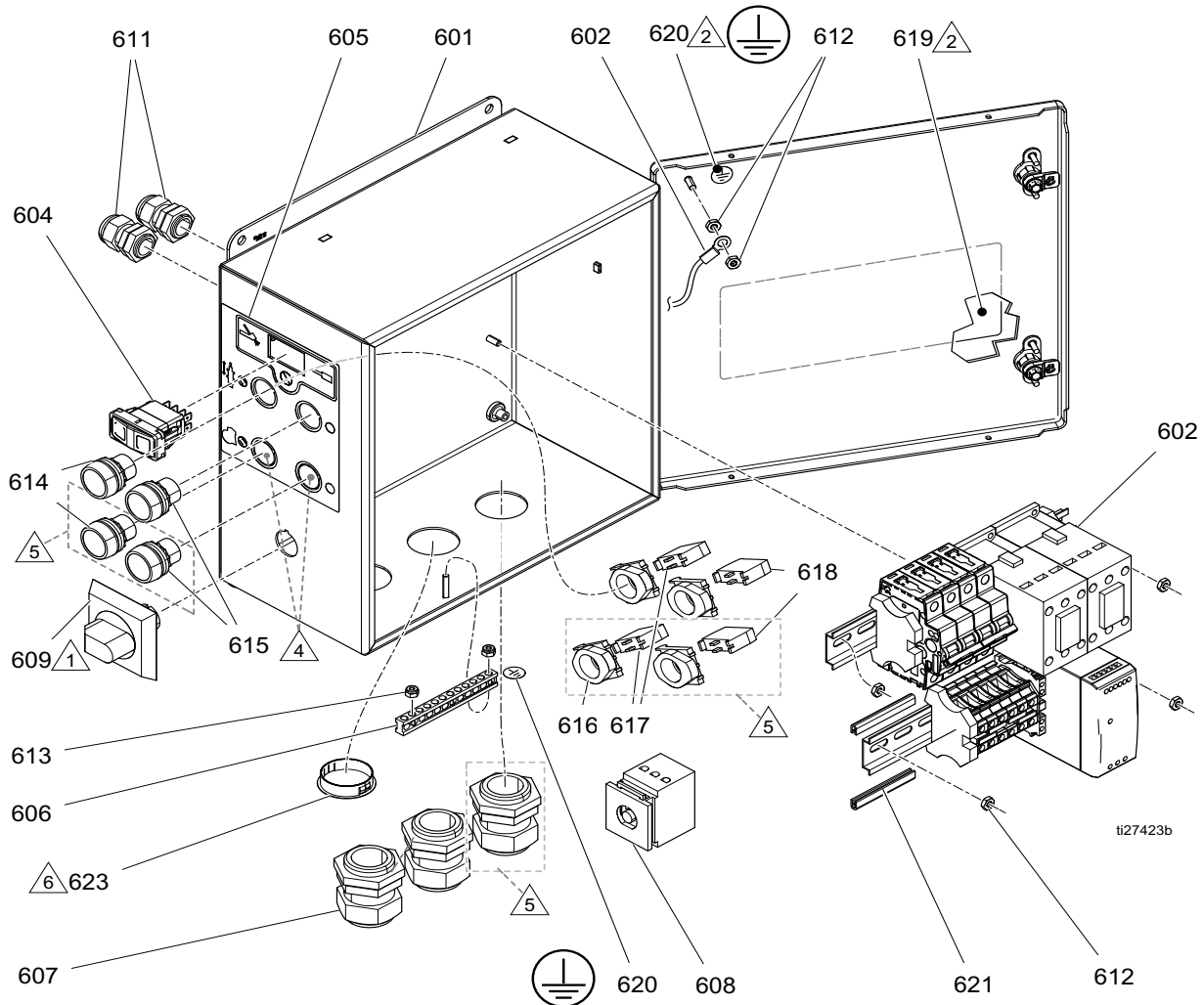

Ref.	Part	Description	Qty.	Ref.	Part	Description	Qty.
601		ENCLOSURE, electrical	1	618	120495	BLOCK, switch, N.C.	2
602		MODULE, brkr, power supply, contact	1	619▲	16T784	LABEL, warning, ENG/FRE/SPA	1
604	17F719	SWITCH, rocker, 3-position	1	620	172953	LABEL, designation	1
605		LABEL, control, electrical enclosure	1	621		TRIM, edge protection	1
606	122313	BAR, ground, kit	1	623	123398	PLUG, hole, 1/5 in. hole diameter	1
607	117682	BUSHING, strain relief	3	▲ Replacement Danger and Warning labels are available at no cost.			
608	123970	SWITCH, disconnect, 40A	1	1 Install disconnect switch (609). Make sure up is ON, and left is OFF.			
609	123971	KNOB, disconnect, operator	1	2 Locate approximately as shown.			
611	114421	BUSHING, strain relief	2	5 For 24Y500 only.			
612	113505	NUT, keps, hex hd	4	6 For 24Y502 only.			
613	109466	NUT, lock, hex	2				
614	121618	SWITCH, start, push button, green	2				
615	121619	SWITCH, stop, push button, red	2				
616	120493	LATCH, mounting	4				
617	120494	BLOCK, switch, N.O.	2				

Breaker, Power Supply, Contact Module

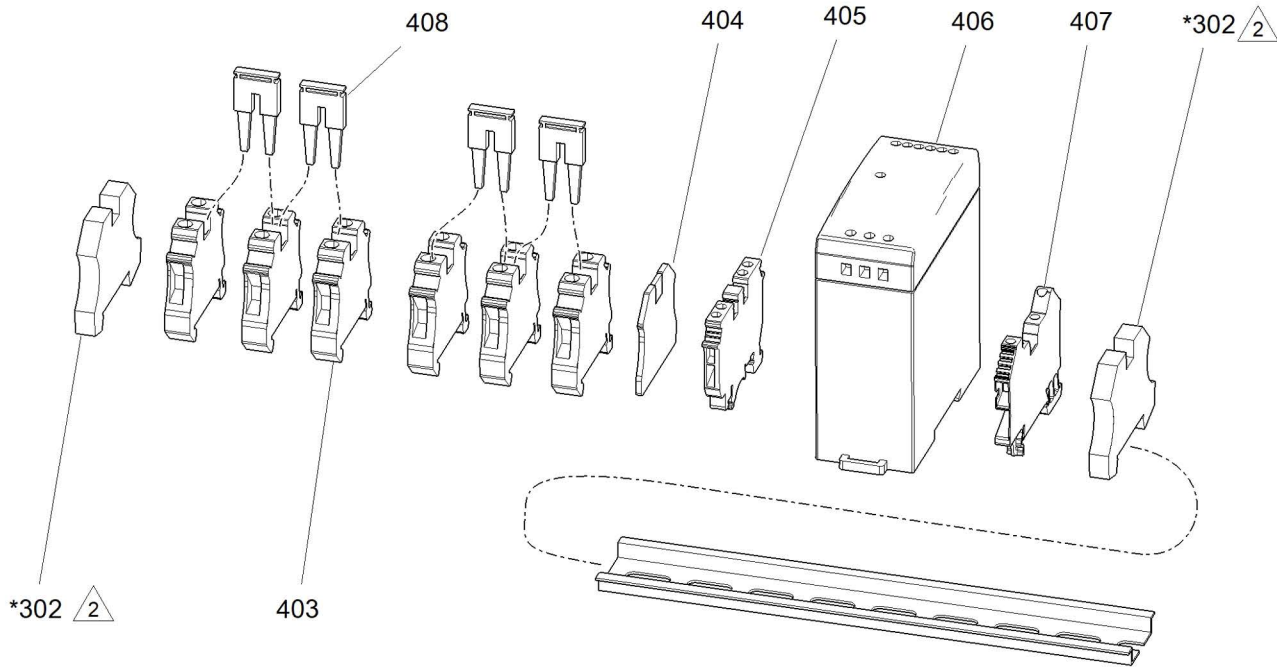

ti27443a

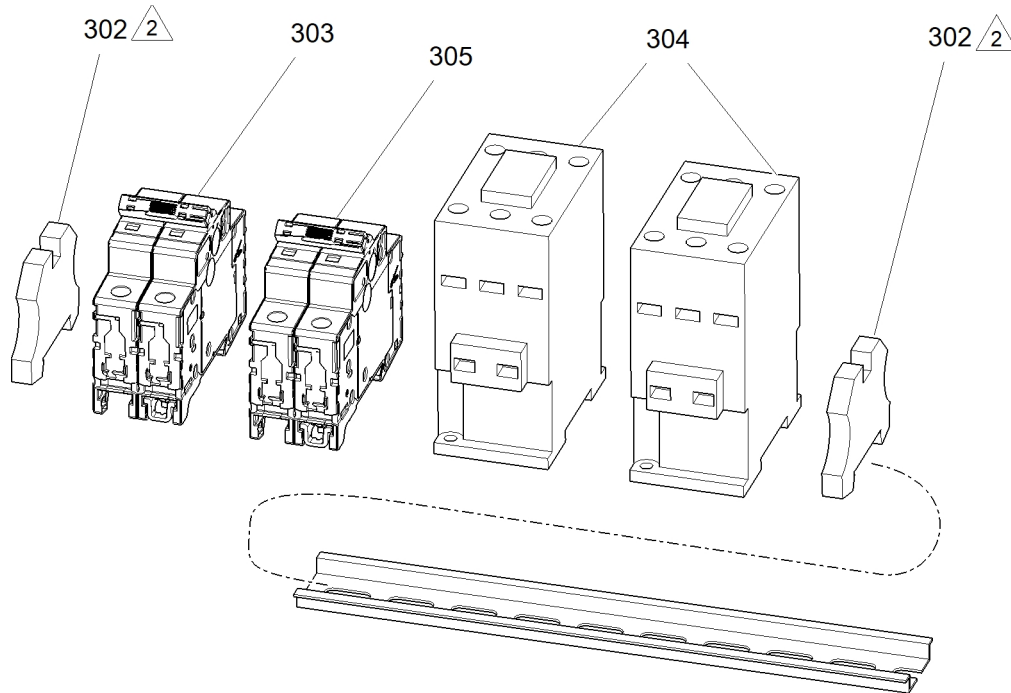

ti27444a

Ref.	Part	Description	Qty.	Ref.	Part	Description	Qty.
302	120838	BLOCK, clamp end	2	405	126812	BLOCK, ground, terminal	1
303	17B346	CIRCUIT, breaker, 2p, 20A, UL1077, AB	2	406	126453	POWER SUPPLY, 24 V	1
304	255022	RELAY, contactor, 65A, 3p	2	407	24R723	BLOCK, terminal, quad M4, AB	1
305	17B347	CIRCUIT, breaker, 2p, 25A, UL1077, AB	1	408	120573	BRIDGE, plug-in (jumper)	4
401	514014	RAIL, mt. (cut to length at assembly)	0.71				
403	120570	BLOCK, terminal	6				
404	120490	COVER, end	1				

 Torque the end stops to 4-5 in-lb (0.45-0.56 N·m).

Reservoir Assembly Parts

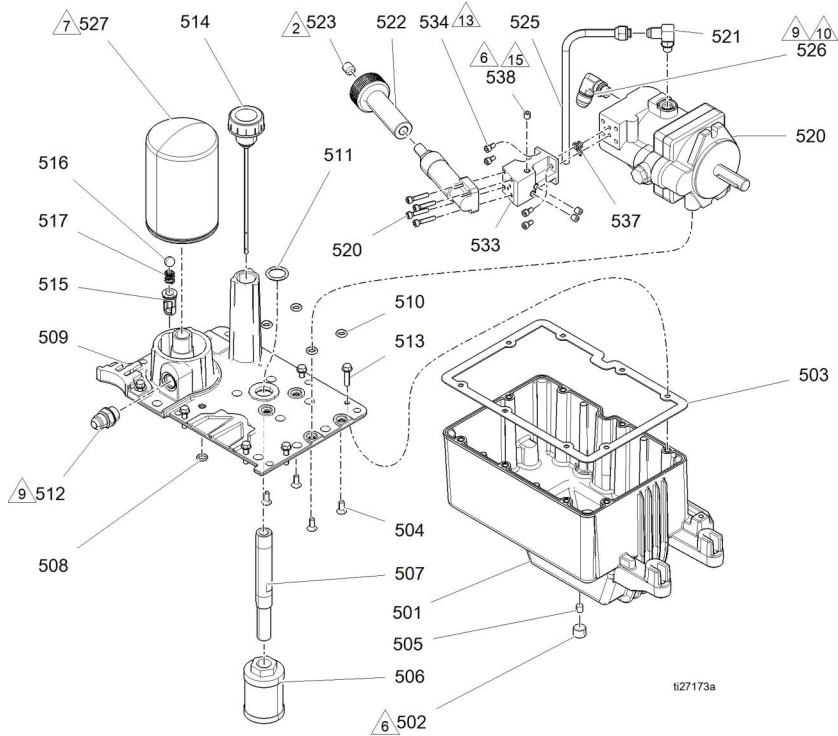

Ref.	Part	Description	Qty.	Ref.	Part	Description	Qty.
501		TANK, reservoir, blue	1	526	118896	FITTING	1
502	107754	PLUG, pipe	1	527	†	FILTER, oil, spin on	1
503	120604	GASKET, reservoir	4	533	17G556	MANIFOLD, pump, 680e	1
504		SCREW, mach, hex flat head	1	534	17G263	SCREW, cap, socket hd, M5 x 10 mm	4
505	116618	MAGNET	1	537	15C939	PACKING, o-ring	3
506		FILTER, screen, suction, hyd	1	538	118579	PLUG, pipe	3
507		TUBE, section	1	▲ Replacement Danger and Warning labels are available at no cost.			
508		PACKING, o-ring	1	† See List of Kits below.			
509		COVER, reservoir, 200HS, blue	1	▲ 6	Apply serviceable thread locker sealant.		
510		PACKING, o-ring	4	▲ 7	Turn 3/4 of a turn after gasket contact, then apply a thin film of oil to gasket prior to assembly.		
511		PACKING, o-ring	1	▲ 9	Torque to 24 ft-lb (34 N-m).		
512	120184	FITTING, hydraulic	1	▲ 10	Tighten with o-ring, washer and jam nut fully retracted, orient and torque jam nut appropriately.		
513		SCREW, mach, hex washer	8	▲ 13	Torque to 70 +/- 5 in-lb (7.9 +/- 0.5 N-m).		
514		CAP, breather, filler	1	▲ 15	Torque to 125 +/- 10 in-lb (14 +/- 1.1 N-m).		
515	†	RETAINER, ball, pressure bypass	1				
516	†	BALL, metallic	1				
517	†	SPRING, compression	1				
520		PUMP, hydraulic	1				
521		FITTING, elbow, male, 90 degree	1				
522		KNOB, pressure	1				
523		SCREW, set, socket head	1				
525		TUBE, hydraulic, case drain	1				

List of Kits

Kit	Description	Ref. # (Qty.)
246173	Kit, repair, oil filter	515 (1), 516 (1), 517 (1), 527 (1)
25A321	F680e complete hydraulic pump and reservoir assembly	All reservoir assembly parts listed above are included.
3A3110L		

Pump Line Parts

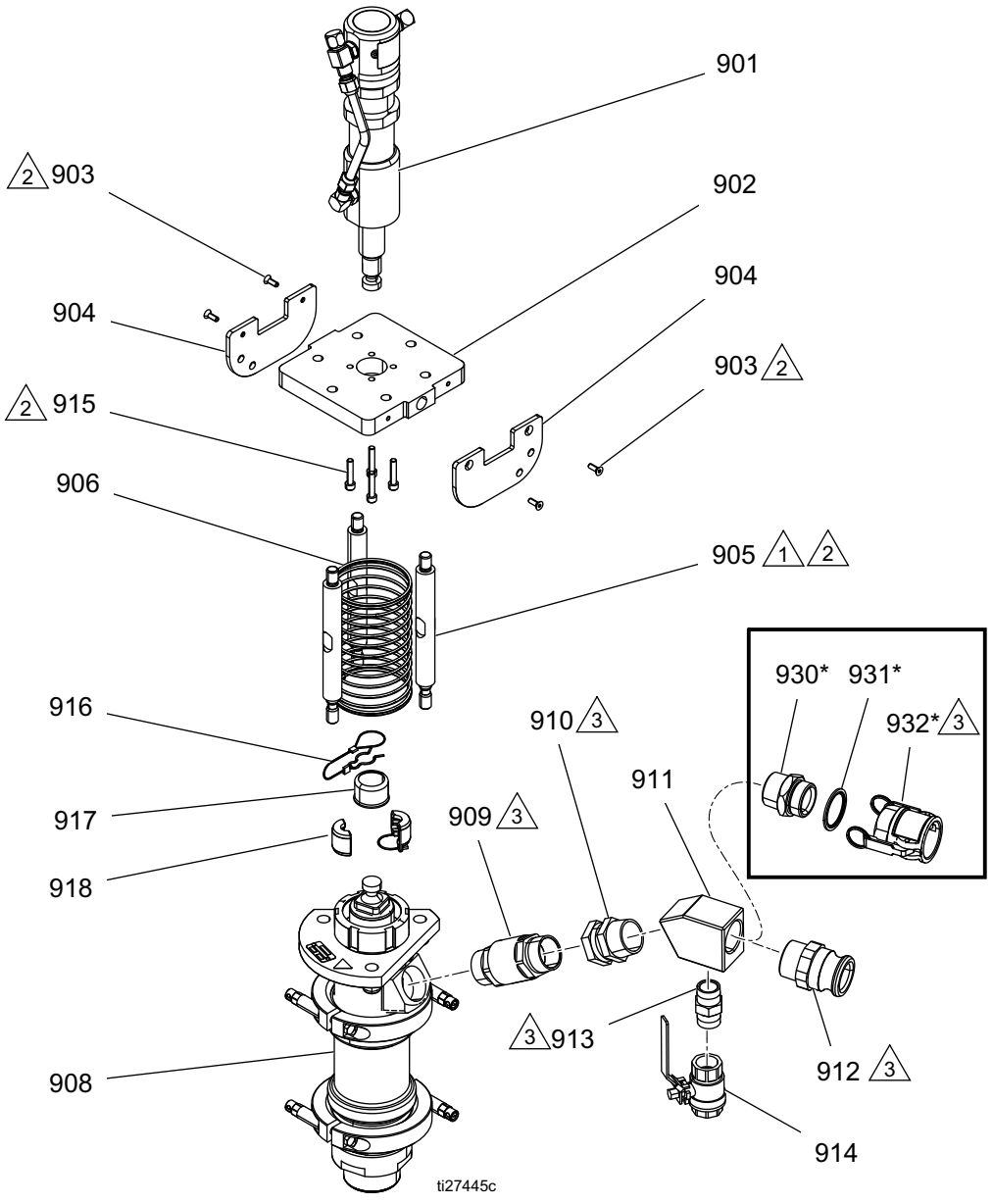



Pump Line Parts List

Ref.	Part	Description	Qty.	Ref.	Part	Description	Qty.
901	25A320	DRIVER, 3.75 in. stroke, 2 in. diameter	1	916	244820	CLIP, hairpin, (with lanyard)	1
902	17G587	PLATE, driver, 680 painted	1	917	197340	COVER, coupler	1
903	103263	SCREW, mach flw, skt	4	918	244819	COUPLING, assembly, 145-290 Xtreme	1
904	17G588	BRACKET, pump, plunger, painted	2	930*	- - -	ADAPTER, 1.5 npt m x 1.5 bspp m	1
905	17G231	TIE, rod	3	931*	17N566	SEAL, 1.5 in. bspp	1
906	17G232	GUARD, spring, pump	1	932*	17N891	COUPLING, 35 mm x 1.5 bspp f	1
907	101712	NUT, lock	3				
908	24Y513	LOWER, pump, 680	1				
909	17H194	VALVE, check, outlet, 1.5 in.	1				
910	113864	UNION, swivel, 1 1/2 npt	1				
911	17G408	MANIFOLD, outlet, pump	1				
912	128473	FITTING, 1.50 cmlk m x 1.50 npt m	1				
913	17G388	FITTING, hose, 1-11 1/2 npt	1				
914	127232	VALVE, ball, 1000 psi, 1 in.	1				
915	113467	SCREW, cap, socket hd	4				

* Additional fittings (mortar coupling) shipped loose with system.

† See **List of Kits** below.

 Torque to 55 +/- 5 ft-lb (74 +/- 6.7 N·m).

 Apply serviceable thread locker to threads.

 Apply pipe sealant to threads.

List of Kits

Kit	Description	Ref. # (Qty.)
24Y513	Complete assembled F680e pump lower	908 (1)
17H194	Complete 1.5 in. outlet check valve	909 (1)
25A320	Complete driver (4.75 in. stroke)	901 (1)
17N875	35 mm x 1.5 npt m adapter kit	930 (1), 931 (1), 932 (1)

Troubleshooting



2. Check all possible problems, causes, and solutions listed below before disassembling pump.

For troubleshooting and repair questions, please contact your local Graco distributor.

1. Perform **Pressure Relief Procedure**, page 26.

Problem	Cause	Solution
Displacement pump operates, but output is low on upstroke	Piston ball check not seating properly	Service the piston ball check.
	Piston packings worn or damaged	Replace the packings.
Displacement pump operates, but output is low on down stroke and/or on both strokes	Piston packings worn or damaged	Tighten packing nut or replace packing.
	Intake valve ball check not seating properly	Service the intake valve ball check.
	Hopper elbow air leak	Tighten the clamps on the hopper elbow.
	Fluid hose/applicator is obstructed	Clear the hose or applicator.
Material leaks and runs over the side of the wet cup	Hose ID is too small	Use a hose with a larger ID.
	Loose wet cup	Tighten wet cup enough to stop leakage.
Fluid delivery is low	Throat packings worn or damaged	Replace the packings.
	Pressure setting too low	Increase the pressure.
	Applicator gun or tip is dirty or clogged	Clean or replace the gun or tip.
	Clamps on hopper elbow are loose	Tighten the clamps on the hopper elbow.
	Hydraulic motor is worn or damaged	Bring the sprayer to a Graco distributor for repair.
The sprayer overheats	Large pressure drop in fluid hose	Reduce hose length and/or increase diameter.
	Material buildup on hydraulic components	Clean the hydraulic components.
Pump noise	Oil level is low	Fill with oil.
	Low hydraulic fluid level	Turn the sprayer OFF and add hydraulic fluid.

Problem	Cause	Solution
Sprayer does not operate	Hydraulic motor solenoid valve is closed	<ol style="list-style-type: none"> 1. Verify the pump control switch (AA) setting. 2. Verify the remote switch position. 3. If the solenoid is not receiving a signal and remains closed when the pump control switch is in the ON position, it can be manually overridden. To override, push the red button in, turn counterclockwise 180°, and release. The solenoid valve will remain open at all times
	Fluid hose or applicator obstructed	Clean the hose or applicator.
	Dried material on displacement rod or inlet ball	Clean rod. Always stop pump at bottom of stroke; keep wet cup filled with TSL. Be sure the inlet ball moves freely.
	Hydraulic ball valve is closed	Verify that the ball valve is in the open position.
Erratic accelerated speed	Material supply exhausted, clogged suction	Refill the hopper and prime pump with material.
	Open or worn piston valve or packings	Clear the piston valve; replace the packings.
	Open or worn intake valve	Clear or service the intake valve.
Cycles or fails to hold pressure at stall	Worn check balls, seats, or piston packing	Service the pump lower.
Poor finish or irregular spray pattern	Inadequate air assist air pressure	Adjust the air assist needle valve on the applicator.
	Dirty, worn, or damaged spray applicator	Service the spray applicator (see Applicator manual 3A3244).
Motor powered but nothing comes out of hose	Pump is packed out with dry or cured material	Disassemble and clean the pump (daily).
	Hose is packed out with dry or cured material	Reduce length and/or increase diameter of the hose.
	Outlet check valve is installed backwards	Install the outlet check valve in the correct orientation.
Material is too thick to push through the hose without packing out	Hose is too restrictive	Thin and mix material thoroughly to a lower viscosity.
		Use a pump system priming fluid (slime). Wet out the system.
		Reduce length and/or increase diameter of the hose.

Problem	Cause	Solution
Hydraulic pump does not develop pressure. Low or zero pressure with screeching noise.	Pump is not primed or lost its prime.	Check dipstick to ensure that hydraulic reservoir is properly filled. Make sure the hydraulic pump inlet fitting is fully tight, to ensure no air is leaking into the hydraulic pump inlet. To prime pump, run unit at lowest pressure setting and slowly increase pressure. In some cases it may be necessary to remove cover shroud, belt guard, and drive belt to allow for manual (counterclockwise) rotation of hydraulic pump. Turn fan pulley by hand. Verify oil flow by removing oil filter to see flow into filter manifold. Reinstall oil filter. Do NOT operate unit without a properly installed oil filter.
	Screeching noise is characteristic of cavitation and is normal at initial startup for a maximum of 30 seconds.	If noise continues longer than 30 seconds, turn off main power disconnect to shut off the motor. Check that the hydraulic pump inlet fittings are tight and that the pump has not lost its prime.
	Hydraulic fluid is too hot.	Ensure that the reservoir is properly serviced. Improve ventilation to allow more efficient heat dissipation.
	Drive belt loose or broken.	Check drive belt condition. Replace if broken.
Electric motor will not start or stop during operation	Loose connections.	Check connections in electrical enclosure. Check for 200-240 VAC at input of motor contactor.
	Circuit breaker tripped.	Reset breaker inside the electrical control box (R).
	Over temperature switch in the motor is tripped.	Wait for the motor to cool, then restart the motor.
Air compressor surging or output low	Restriction in air compressor outlet path.	Verify that the air hoses, fittings, and cooling tube on the machine are free of debris. Also, verify that the air relief valve (part 17H606) and muffler (part 120206) are clean and free of debris.
Air compressor motor stops during operation	Circuit breaker tripped.	Verify that the air hoses, fittings, and cooling tube on the machine are free of debris. Also, verify that the air relief valve (part 17H606) and muffler (part 120206) are clean and free of debris.
	Over temperature switch in the motor is tripped.	Wait for the motor to cool, then restart the motor.

Replacement Parts and Accessories

Accessories	
24Y479	F680e forklift stabilization kit
17H197	Kit, remote switch, cable (remote ON/OFF switch with 100 ft (30 m) of cable)
17G665	Kit, remote switch, extension cord (110 ft, 33.5 m)
114271	Strap, retaining
240296	Kit, retaining straps, 4 pack
17J703	Kit, ball, valve (material hose ball valve attachment)
121441	Fitting, 1-1/2 NPT, nipple (check valve replacement nipple fitting)
Belts	
17G244	Belt, AX, air compressor (AX44 cogged V-belt)
125834	Belt, tri-power, AX48, hydraulic (AX48 cogged V-belt)
Air Compressor	
125809	Lubricant, oil, synthetic
24N370	Pump, compressor, air (air compressor)
121366	Kit, air filter (replacement air filter element and cover)
Hydraulic System	
246173	Kit, repair, oil filter
25A320	Kit, driver, 4.75 in. stroke (complete driver)
25A321	Kit reservoir, assembly, F680e (complete hydraulic pump and reservoir)

Repair Parts

Lower Assembly	
16W490	Kit, repair 10 pack o-ring, cylinder end (cylinder o-ring)
17G456	Kit, lower, clamp (cylinder clamp)
17H242	Kit, repair, pump rebuild
24Y513	Kit, pump, lower, F680e (complete assembled F680e pump lower)
Inlet	
16W510	Kit, repair, seat, inlet (inlet seat and o-ring)
112420	Ball, sst, 1590 (1.75 in. diameter inlet check ball)
Piston	
17H191	Kit, piston seat, o-ring (piston seat and o-ring)
108001	Ball, metallic (1.5 in. diameter piston check ball)
16W491	Kit, repair, 3 pack, seal, piston (piston packing cup)
Outlet	
16W492	Kit, repair, 3 pack, seal, throat (throat seal)
Rubber Elbow	
17H193	Kit, inlet elbow (rubber elbow)
17H196	Kit, elbow, band clamp (rubber elbow clamp)
Check Valve	
17H192	Kit, outlet seat, o-ring (seat and o-ring)
17H194	Kit, outlet, check, valve (complete 1.5 in. outlet check valve)
102973	Ball, metallic (1.25 in. diameter outlet check ball)
113082	Packing, o-ring (check valve packing o-ring)
17J712	Kit, check, retainer (check valve ball retainers)

Electrical Schematics

Incoming Power

200-240 VAC 1Φ with compressor

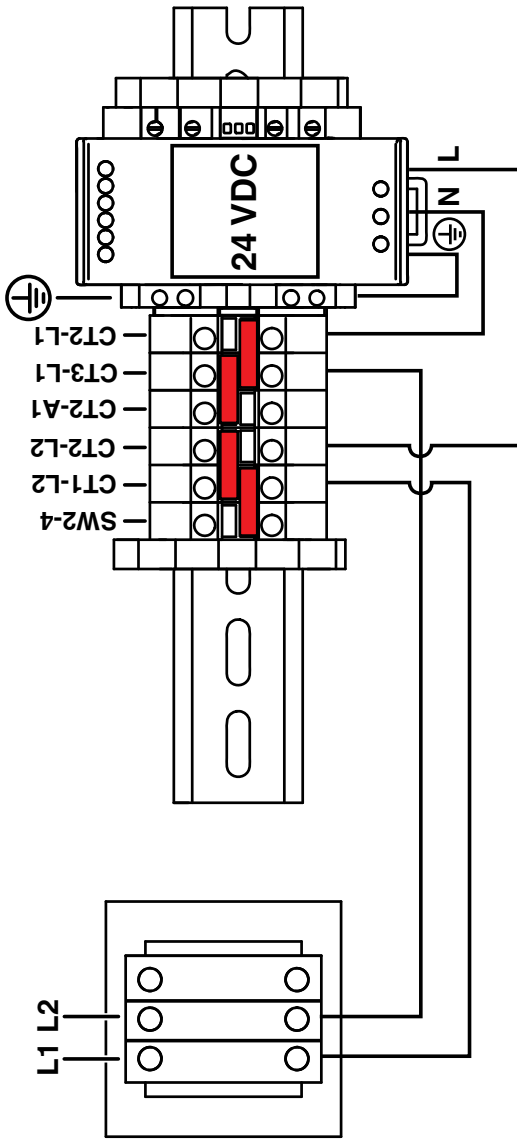

200-240 VAC 1Φ no compressor

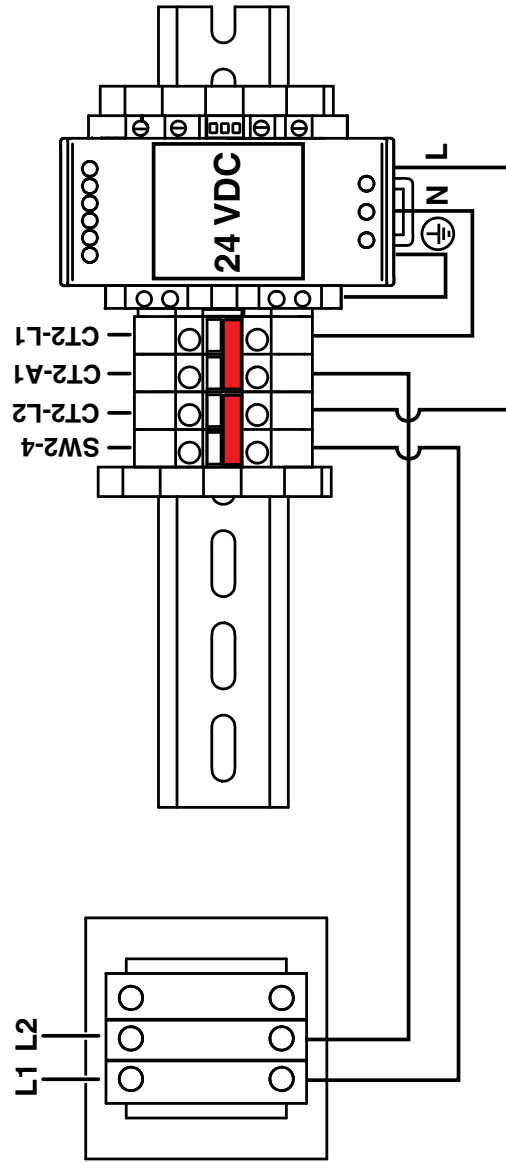

Motor and Motor Control

NOTE: Compressor motor and related components are only present in systems with an integrated air compressor.

INSIDE ELECTRICAL CONTORL BOX

230V

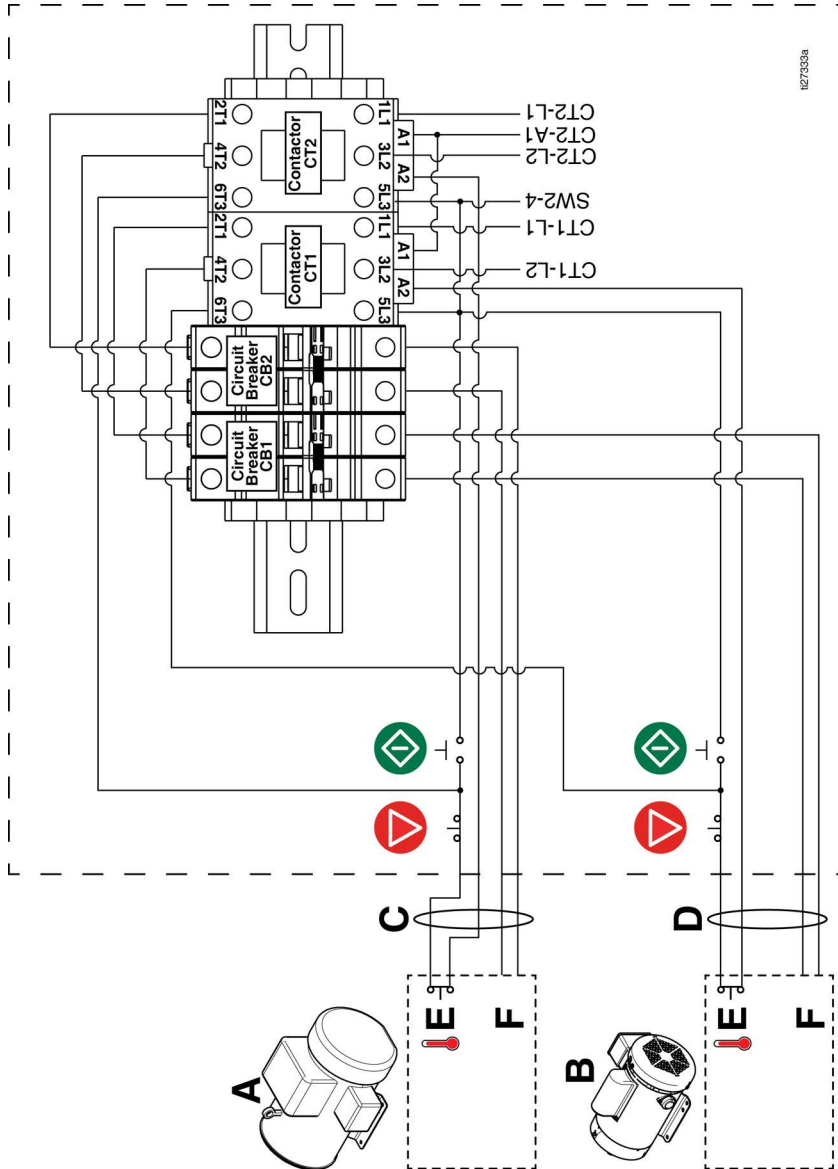

Diagram Key

Ref.	Description
A	Motor, hydraulic
B	Motor, compressor
C	Harness, hydraulic motor
D	Harness, compressor motor
E	Over-temperature
F	Power

Motor Junction Box Wiring Connections

Wiring Level	Color	Motor Wire
MTR1	Black	#4 and #5
MTR2	White	#1 and #8
PE	Green	GND Lug
OT1	Orange	J
OR2	Red	J

Pump Control

INSIDE ELECTRICAL CONTROL BOX

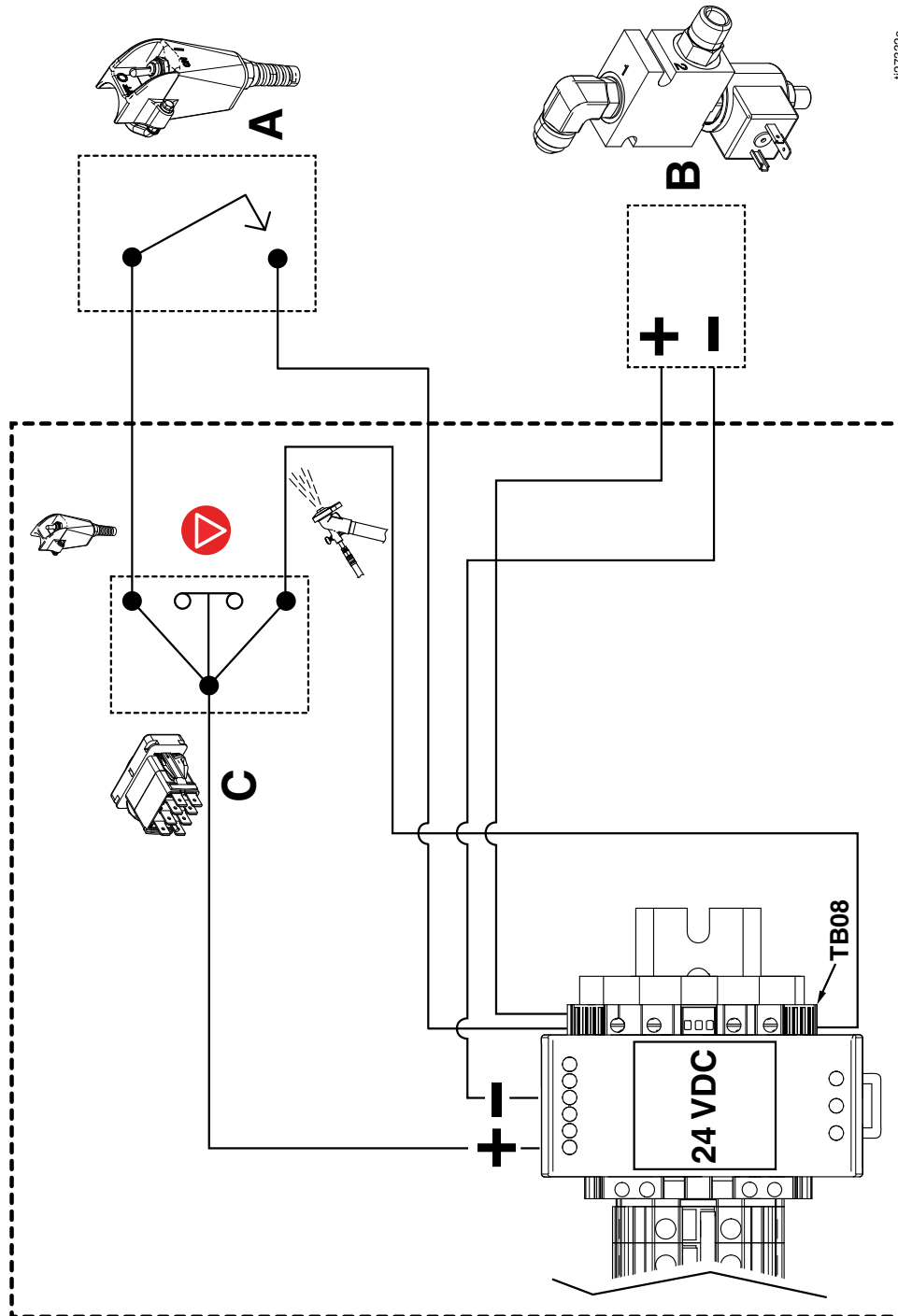

Diagram Key

Ref.	Description
A	Remote Switch
B	Hydraulic Solenoid Valve
C	Pump Control Switch

Technical Specifications

ToughTek F680e Fireproofing Pump		
	US	Metric
Maximum Fluid Working Pressure	600 psi	4.41 MPa, 41.4 Bar
Stroke Length	4.75 in.	120 mm
Maximum pump speed (Do not exceed maximum recommended speed of fluid pump to prevent premature pump wear)	77 cycles per minute	
Weight (empty)	625 lb	283.5 kg
Wetted Parts	Stainless steel, plated steel, carbide, urethane, PTFE, UHMWPE, LLDPE, aluminum, solvent-resistant o-rings	
Hydraulic Tank Capacity	1.25 gallons	4.73 liters
Oil Specification	Graco Hydraulic Oil, ISO 46 169236 (5 gallons / 18.9 liter) or 207428 (1 gallon / 3.8 liter)	
Maximum Pump Line Speed		
60 Hz	77 cycles per minute	
Inlet/Outlet Sizes		
Fluid Inlet Size	3 in.	
Fluid Outlet Size	1.5 in. npt(f) with 1.5 in. male camlock	
Hose Requirements		
Minimum Pressure	600 psi	4.41 MPa, 41.4 Bar
Minimum Hose Diameter	1 in.	2.54 cm
Minimum Hose Length	25 ft	7.6 m
Air Compressor Performance		
Maximum Working Air Pressure	85 psi	5.9 bar (0.59 MPa)
Maximum Air Compressor Output	10 cfm at 40 psi	17 m ³ /h at 2.7 bar (0.27 MPa)
Sound Pressure, measured at 3.1 ft (1 m) per ISO 3744		
Model 24Y500	82.8 dB(A)	
Model 24Y502	80.2 dB(A)	
Sound Power, measured at 3.1 ft (1 m) per ISO 3744		
Model 24Y500	93.1 dB(A)	
Model 24Y502	90.9 dB(A)	
Operating Ambient Temperature		
Temperature	32° F to 120° F	4° C to 49° C
Dimensions		
Height	46 in.	117 cm
Width	33 in.	84 cm
Length	62.25 in.	158 cm
Weight		
Model 24Y500	625 lb	284 kg
Model 24Y502	515 lb	234 kg

Graco Standard Warranty

Graco warrants all equipment referenced in this document which is manufactured by Graco and bearing its name to be free from defects in material and workmanship on the date of sale to the original purchaser for use. With the exception of any special, extended, or limited warranty published by Graco, Graco will, for a period of twelve months from the date of sale, repair or replace any part of the equipment determined by Graco to be defective. This warranty applies only when the equipment is installed, operated and maintained in accordance with Graco's written recommendations.

This warranty does not cover, and Graco shall not be liable for general wear and tear, or any malfunction, damage or wear caused by faulty installation, misapplication, abrasion, corrosion, inadequate or improper maintenance, negligence, accident, tampering, or substitution of non-Graco component parts. Nor shall Graco be liable for malfunction, damage or wear caused by the incompatibility of Graco equipment with structures, accessories, equipment or materials not supplied by Graco, or the improper design, manufacture, installation, operation or maintenance of structures, accessories, equipment or materials not supplied by Graco.

This warranty is conditioned upon the prepaid return of the equipment claimed to be defective to an authorized Graco distributor for verification of the claimed defect. If the claimed defect is verified, Graco will repair or replace free of charge any defective parts. The equipment will be returned to the original purchaser transportation prepaid. If inspection of the equipment does not disclose any defect in material or workmanship, repairs will be made at a reasonable charge, which charges may include the costs of parts, labor, and transportation.

THIS WARRANTY IS EXCLUSIVE, AND IS IN LIEU OF ANY OTHER WARRANTIES, EXPRESS OR IMPLIED, INCLUDING BUT NOT LIMITED TO WARRANTY OF MERCHANTABILITY OR WARRANTY OF FITNESS FOR A PARTICULAR PURPOSE.

Graco's sole obligation and buyer's sole remedy for any breach of warranty shall be as set forth above. The buyer agrees that no other remedy (including, but not limited to, incidental or consequential damages for lost profits, lost sales, injury to person or property, or any other incidental or consequential loss) shall be available. Any action for breach of warranty must be brought within two (2) years of the date of sale.

GRACO MAKES NO WARRANTY, AND DISCLAIMS ALL IMPLIED WARRANTIES OF MERCHANTABILITY AND FITNESS FOR A PARTICULAR PURPOSE, IN CONNECTION WITH ACCESSORIES, EQUIPMENT, MATERIALS OR COMPONENTS SOLD BUT NOT MANUFACTURED BY GRACO. These items sold, but not manufactured by Graco (such as electric motors, switches, hose, etc.), are subject to the warranty, if any, of their manufacturer. Graco will provide purchaser with reasonable assistance in making any claim for breach of these warranties.

In no event will Graco be liable for indirect, incidental, special or consequential damages resulting from Graco supplying equipment hereunder, or the furnishing, performance, or use of any products or other goods sold hereto, whether due to a breach of contract, breach of warranty, the negligence of Graco, or otherwise.

FOR GRACO CANADA CUSTOMERS

The Parties acknowledge that they have required that the present document, as well as all documents, notices and legal proceedings entered into, given or instituted pursuant hereto or relating directly or indirectly hereto, be drawn up in English. Les parties reconnaissent avoir convenu que la rédaction du présente document sera en Anglais, ainsi que tous documents, avis et procédures judiciaires exécutés, donnés ou intentés, à la suite de ou en rapport, directement ou indirectement, avec les procédures concernées.

Graco Information

For the latest information about Graco products, visit www.graco.com.

For patent information, see www.graco.com/patents.

TO PLACE AN ORDER, contact your Graco distributor or call to identify the nearest distributor.

Toll Free Phone Number: 1-800-328-0211

*All written and visual data contained in this document reflects the latest product information available at the time of publication.
Graco reserves the right to make changes at any time without notice.*

Original instructions. This manual contains English. MM 3A3110

Graco Headquarters: Minneapolis

International Offices: Belgium, China, Japan, Korea

GRACO INC. AND SUBSIDIARIES • P.O. BOX 1441 • MINNEAPOLIS MN 55440-1441 • USA
Copyright 2020, Graco Inc. All Graco manufacturing locations are registered to ISO 9001.

www.graco.com
Revision L, November 2024