

RoadLazer™ RoadPak™ Tow-Behind System

3A2091E

EN

For the application of road marking and reflective coatings. For professional use only.

List of Models (see page 2)

2900 psi (20 MPa, 200 bar) Maximum Working Pressure



Important Safety Instructions

Read all warnings and instructions in this manual. Save these instructions.

Trailer Ratings

- Gross Vehicle Weight Rating (GVWR)
2800 lb (1270 kg)
- Gross Axle Weight Rating (GAWR)
1200 lb (544 kg) per axle with 5.70 x 8
tire, 8 x 3.75 5-45 rim at
100 psi (690 KPA) cold single.

Tire Ratings

Size: 5.70 x 8, Load Range D
Cold tire pressure: 100 psi (690 KPA)
Lug Torque: 90-120 ft-lb (122-163 N•m)

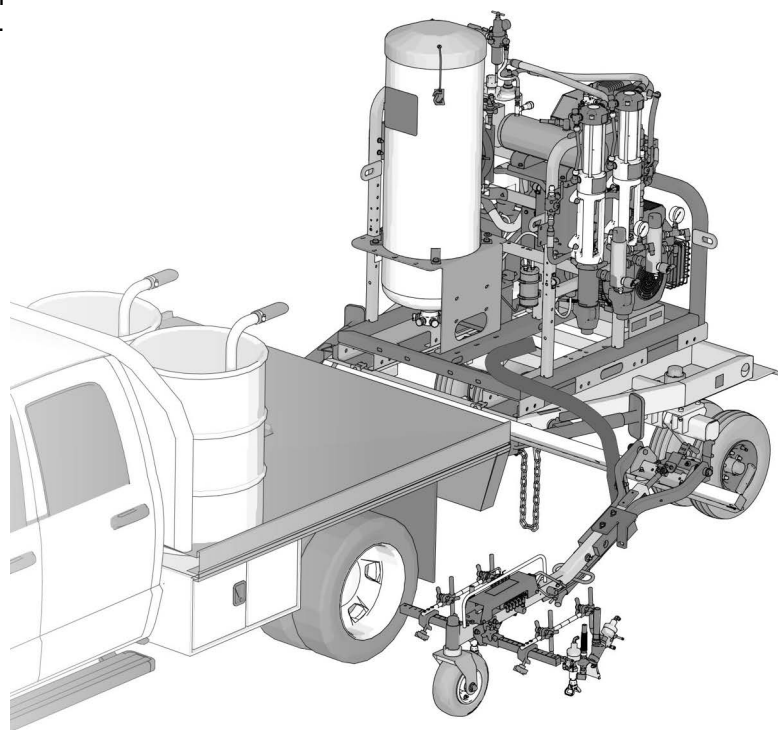

t18134b

NOTE: This manual replaces the Operation Manual (3A5384) for the standard RoadLazer™ RoadPak™ Line Striping System.

Table of Contents

Models	3	Operation	27
Complete Assemblies	3	Grounding	27
Warnings	4	Pressure Relief Procedure	27
Introduction and General Information	7	EMERGENCY SHUT OFF	28
Introduction	7	Load Reflecting Materials	28
General Information	7	Set Up Slide Beam and Gun Arm	29
Component Identification	8	Prepare System to Paint	29
Component Function	9	Start Engine	31
Pre-Setup Requirements	10	Begin to Spray	33
Tow Vehicle Requirements	10	Flush the System	34
Hitch Requirements	10	Securing Gun Arm for Transportation	36
Receivers	10	Removing RoadLazer from Vehicle	37
Paint Drum Bracket	10	Repair	38
Programmable Skipline Controller	10	Trailer Tire	38
Hitch Receiver Kit: 238944 (Standard)	11	Trailer Tire Replacement	38
Installation Instructions for Hitch Kit 238944 (straight cross tube)	11	General Trailer Service	38
Hitch Receiver Kit: 239692 (Optional)	12	Parts	39
Installation Instructions for Hitch Kit 239692 (angled cross tube)	12	Parts List	39
Setup	13	Parts	40
Charge Battery	13	Parts List	40
Grounding Instructions	13	Technical Data	41
Level Draw Bar with Tow-Behind System	13	Graco Standard Warranty	42
Connect Tow-Behind to Vehicle	13	Graco Information	42
Trailer Tires	14		
Gun Arm Beam Bracket	15		
Gun Arm Stow Bracket	15		
Installing RoadLazer onto Trailer	16		
Adjustable Gun Arm Beam Installation (24G630)	16		
Adjustable Gun Arm Installation (25M708, 25M709) 17	17		
Install Safety Switch and Gun Arm Stow Plate	17		
Hose Routing to Pumps and Tanks	20		
Filter Orientation	21		
Hose Routing	21		
Wiring Diagrams	25		
Install Simple Guide System	26		

Models



Ref.	Model Number	Description
1	25M701	1 Pump RoadPak (450 lb. Bead Tank, 5 gpm)
2	25M703	2 Pump RoadPak (450 lb. Bead Tank, 5 gpm)
3	25M708	1 Pump RoadPak Gun Arm
4	25M709	2 Pump RoadPak Gun Arm
5	24G630	Adjustable Gun Arm Beam
6	25M711	Programmable Skipline Controller
7	24G633	RoadView™ Camera System
8	24G634	Simple Guide System
9	24M255	Siphon and Drain Hose Extension Kit (Waterborne)
10	16M239	RoadPak Trailer (mounting parts not included)
11	238944	Hitch Receiver Kit (class 4, 2 in.)
12	24M138	Trailer Mounting Parts

Complete Assemblies

Part Number	Description
25M836	1 Pump Tow-Behind RoadPak System (1, 3, 5, 6, 8, 9, 10, 11, 12)
25M837	2 Pump Tow-Behind RoadPak System (2, 4, 5, 6, 8, 9 (x2), 10, 11, 12)
24M200	Tow-Behind Trailer Conversion Kit (9 (x2), 10, 11, 12)
25M838	1 Pump Tow-Behind System with Camera (1, 3, 5, 6, 7, 8, 9, 10, 11, 12)
25M839	2 Pump Tow-Behind System with Camera (2, 4, 5, 6, 7, 8, 9 (x2), 10, 11, 12)





Warnings

The following warnings are for the setup, use, grounding, maintenance, and repair of this equipment. The exclamation point symbol alerts you to a general warning and the hazard symbols refer to procedure-specific risks. When these symbols appear in the body of this manual, refer back to these Warnings. Product-specific hazard symbols and warnings not covered in this section may appear throughout the body of this manual where applicable.

 <h2 style="margin: 0;">WARNING</h2>	
	<p>TOWING HAZARD</p> <p>The driver can lose control when pulling trailer if correct equipment is not used. The driver and passengers could be seriously injured. The vehicle or system may also be damaged.</p> <ul style="list-style-type: none"> • Tow vehicle must meet all requirements and load ratings. See Tow Vehicle Requirements. • Clamp-on hitch receivers must be installed properly. See Tow Hitch Requirements. • Do not use additional bead or paint tanks on Tow-Behind System. • Clamp on hitch receivers are to be used for towing Graco double-hitch equipment only. Do not tow any other equipment with these receivers. • Do not use Tow-Behind System trailer for other equipment.
	<p>FIRE AND EXPLOSION HAZARD</p> <p>Flammable fumes, such as solvent and paint fumes, in work area can ignite or explode. Paint or solvent flowing through the equipment can cause static sparking. To help prevent fire and explosion:</p> <ul style="list-style-type: none"> • Use equipment only in well-ventilated area. • Eliminate all ignition sources, such as pilot lights, cigarettes, portable electric lamps, and plastic drop cloths (potential static sparking). • Ground all equipment in the work area. See Grounding instructions. • Never spray or flush solvent at high pressure. • Keep work area free of debris, including solvent, rags and gasoline. • Do not plug or unplug power cords, or turn power or light switches on or off when flammable fumes are present. • Use only grounded hoses. • Hold gun firmly to side of grounded pail when triggering into pail. Do not use pail liners unless they are anti-static or conductive. • Stop operation immediately if static sparking occurs or you feel a shock. Do not use equipment until you identify and correct the problem. • Keep a working fire extinguisher in the work area.



WARNING

	<p>SKIN INJECTION HAZARD High-pressure fluid from dispensing device, hose leaks, or ruptured components will pierce skin. This may look like just a cut, but it is a serious injury that can result in amputation. Get immediate SURGICAL TREATMENT.</p> <ul style="list-style-type: none"> • Keep clear of fluid outlet and leaks. • Use guns, hoses and other components with pressure ratings equal to or higher than the pump rating. • Follow the Pressure Relief Procedure before servicing or cleaning. • Do not point dispensing device at anyone or at any part of the body. • Do not stop or deflect leaks with your hand, body, glove, or rag. • Tighten all fluid connections before operating the equipment. • Check hoses and couplings daily. Replace worn or damaged parts immediately.
	<p>MOVING PARTS HAZARD Moving parts can pinch, cut or amputate fingers and other body parts.</p> <ul style="list-style-type: none"> • Keep clear of moving parts. • Do not operate equipment with protective guards or covers removed. • Do not wear loose clothing, jewelry or long hair while operating equipment. • Pressurized equipment can start without warning. Before checking, moving, or servicing equipment, follow the Pressure Relief Procedure and disconnect all power sources.
	<p>EQUIPMENT MISUSE HAZARD Misuse can cause death or serious injury.</p> <ul style="list-style-type: none"> • Do not operate the unit when fatigued or under the influence of drugs or alcohol. • Do not exceed the maximum working pressure or temperature rating of the lowest rated system component. See Technical Data in all equipment manuals. • Use fluids and solvents that are compatible with equipment wetted parts. See Technical Data in all equipment manuals. Read fluid and solvent manufacturer's warnings. For complete information about your material, request MSDS from distributor or retailer. • Do not leave the work area while equipment is energized or under pressure. Turn off all equipment and follow the Pressure Relief Procedure when equipment is not in use. • Check equipment daily. Repair or replace worn or damaged parts immediately with genuine manufacturer's replacement parts only. • Do not alter or modify equipment. • Use equipment only for its intended purpose. Call your distributor for information. • Route hoses and cables away from traffic areas, sharp edges, moving parts, and hot surfaces. • Do not kink or over bend hoses or use hoses to pull equipment. • Keep children and animals away from work area. • Comply with all applicable safety regulations.
	<p>CARBON MONOXIDE HAZARD Exhaust contains poisonous carbon monoxide, which is colorless and odorless. Breathing carbon monoxide can cause death.</p> <ul style="list-style-type: none"> • Do not operate in an enclosed area.
	<p>TOXIC FLUID OR FUMES HAZARD Toxic fluids or fumes can cause serious injury or death if splashed in the eyes or on skin, inhaled, or swallowed.</p> <ul style="list-style-type: none"> • Read MSDSs to know the specific hazards of the fluids you are using. • Store hazardous fluid in approved containers, and dispose of it according to applicable guidelines.

WARNING



BURN HAZARD

Equipment surfaces and fluid that's heated can become very hot during operation. To avoid severe burns:

- Do not touch hot fluid or equipment.



PERSONAL PROTECTIVE EQUIPMENT

Wear appropriate protective equipment when in the work area to help prevent serious injury, including eye injury, hearing loss, inhalation of toxic fumes and burns. This equipment includes but is not limited to:

- Protective eyewear, and hearing protection.
- Respirators, protective clothing, and gloves as recommended by the fluid and solvent manufacturer.

CALIFORNIA PROPOSITION 65

The engine exhaust from this product contains a chemical known to the State of California to cause cancer, birth defects or other reproductive harm.

Introduction and General Information

Introduction

This manual and those supplied provide pre-setup requirements, parts lists, setup, operation, and maintenance instructions for the RoadLazer RoadPak Tow-Behind System. This manual includes instructions for a 2-pump system. For 1-pump systems, all parts remain the same with the exception of plugged ports for excluded pumps and hoses.

General Information

The Tow-Behind System is attached to a vehicle and is used to apply up to two stripes in one or two colors with glass beading.

The Tow-Behind System consists of a Programmable Skipline Controller, Displacement Pumps, two Paint Spray Guns, and two Bead Spray Guns.

Programmable Skipline Controller

The Programmable Skipline Controller consists of the control box and a 30 ft (9.1 m) cable. It is the main control for the Tow-Behind System and turns the spray guns and accessories on and off.

Simple Guide System

The Simple Guide System provides the user with a pointer for alignment on either the left or right side of the vehicle.

RoadView™ Camera System (optional)

The RoadView Camera System provides the user with video of a bore sight view for alignment on either the left or right side of the tow vehicle. The system consists of a 9 in. monitor, interfacing cables, video camera and mounting bracket.

RPS 2900 Hydraulic Pumps

The RPS 2900 Hydraulic Pump supplies paint to the spray guns. There are two displacement pumps. Two displacement pumps allows the user to have a two-color system.

Paint Spray Guns

The Paint Spray Guns are pneumatically triggered to spray paint stripes when commanded by the Programmable Skipline Controller.

Bead Spray Guns

The Bead Spray Guns are pneumatically triggered to spray reflective materials when commanded by the Programmable Skipline Controller.

Component Identification

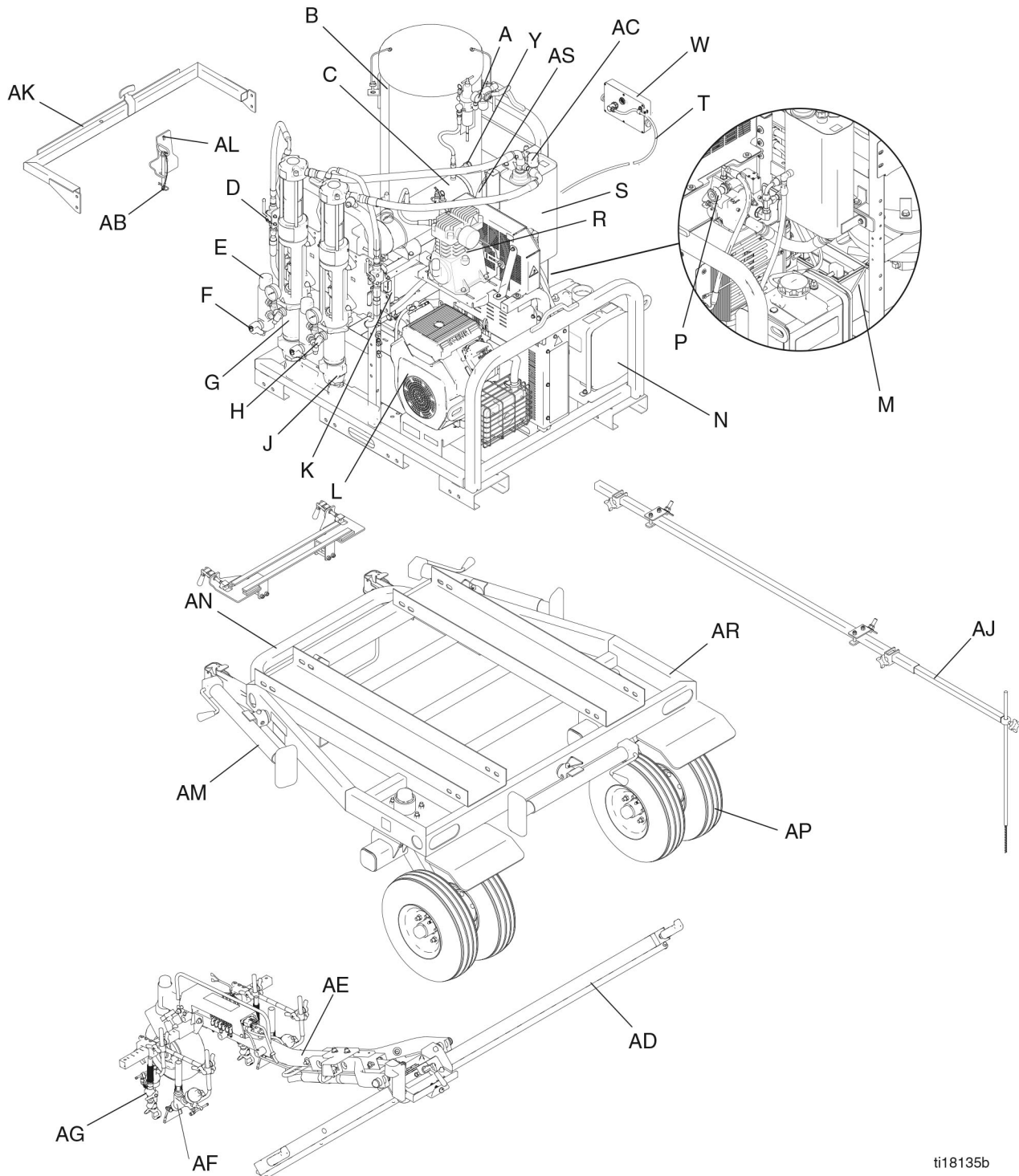

ti18135b

Component Function

A	Air Regulator	Allows regulation of the bead tank air pressure
B	Bead Tank	Holds up to 36 gallons (136 liters) of reflective materials or element for single or double drop beading
C	Air Accumulator Tank	Helps maintain consistent air power to accessories
D	Hydraulic Valve	Valve to shut off/on the hydraulic fluid to the hydraulic motor
E	Fluid Filter	Filters fluid between the fluid source and the spray gun
F	Prime/Spray Valve	Relieves fluid pressure when open
G	RPS 2900 Hydraulic Pump	Provides fluid to be sprayed through the spray gun
H	Fluid Outlet	Supplies fluid from the displacement pump to the spray gun
J	Fluid Inlet	Displacement Pump entry for fluid from the paint drums (paint drums not shown)
K	Electrical Junction Box	Allows the user access to electrical system
L	18 HP Engine	Powers the hydraulic pump and the air compressor
M	Battery	Provides power to start the engine and control box
N	Fuel Tank	Holds 6 gallons (23 liters) of gasoline
P	Hydraulic Pressure Control Knob	Provides adjustment of hydraulic pressure (clockwise increases pressure)
R	Compressor	Provides an air supply for the solenoids and pressurizes the bead tanks
S	Hydraulic Reservoir	Holds 4 gallons (15.1 liters) of hydraulic oil for the hydraulic pump
T	I/O Cable	Carries electronic control signals from the controller to the RoadLazer
W	Programmable Skipline Controller	Allows the user to program the operation of the RoadLazer
Y	Air Pressure Quick Connect	Allows the user to use pressurized air
AB	Stow Bracket Pin	Secures the spray gun boom arm when the RoadLazer is in transport mode
AC	Breather Cap	Provides a means for hydraulic reservoir ventilation, oil check, and fill
AD	Adjustable Gun Arm Beam	Supports the RoadPak Gun Arm
AE	RoadPak Gun Arm	Allows striping on either side of the vehicle at adjustable distances
AF	Bead Spray Gun	Sprays beads when commanded by the Controller
AG	Paint Spray Gun	Sprays fluid when controlled by the Controller
AJ	Simple Guide System	Provides an alignment tool for the user
AK	Gun Arm Stow Bracket	Allows upright storage of RoadPak gun arm
AL	Gun Arm Stow Plate	Allows connection between stow bracket and spray gun boom arm
AM	Trailer Jack	Used to hold Tow-Behind System upright when disconnected from tow vehicle and during storage
AN	Gun Arm Beam Bracket	Supports the slide beam
AP	Wheel Assembly	Supports RoadLazer RoadPak trailer
AR	RoadLazer RoadPak Trailer	Allows user to tow RoadPak behind a vehicle
AS	Air Cooler/Dryer	Cools and dries air bead tank and accessories

Pre-Setup Requirements

Tow Vehicle Requirements

- Tow vehicle with minimum wheel base (front to back) of 130 in (330 cm).
- Tow vehicle with minimum rated payload capacity of 3500 lb (1588 kg). **NOTE:** Tongue weight (TW) of Tow-Behind System is 1000 lb (454 kg).
- Tow vehicle with minimum rated capacity of 7500 lb (3402 kg) gross trailer weight (GTW)
- Tow hitch with minimum rated capacity of 750 lb (340 kg) TW, 7500 lb (3402 kg) GTW.
- Warning lights and/or sign board per federal, state, and local regulations. Reference Part IV of the Manual on Uniform Traffic Control Devices (MUTCD) by the U.S. Department of Transportation, Federal Highway Administration, or equivalent regulations for your region.
- Securing device for paint supply containers.
- Standard trailer light connector.
- I/O cable access from the tow vehicle cab to the RoadLazer.

Hitch Requirements

Have a DRAW-TITE® Class IV Ultra-Frame tow hitch (or equivalent hitch with a 7500 lb (3402 kg) GTW rating and 3 in. x 3 in. (7.6 cm x 7.6 cm) square cross tube) installed on your vehicle (reference DRAW-TITE part no. series 419XXX). **NOTE:** Tow hitch not supplied by Graco.

Choose a ball mount that allows the Tow-Behind System to travel level to the ground with an average payload. A recommended option is two DRAW-TITE adjustable 2 in. (5 cm) ball mounts. The ball mount must have a 2 in. x 2 in. (5 cm x 5 cm) insert with at least a 1 in. diameter ball

mount hole. The ball mount hole and shank diameter must match. The ball mount must have a rating of at least 5000 lb (2270 kg) GTW, 5000 lb (2270 kg) TW.

Receivers

Two Graco clamp-on receivers must be mounted 36 in. (91 cm) on center on the installed DRAW-TITE Class IV Ultra Frame Hitch. See **Hitch Receiver Kit** for mounting instructions, pages 11 and 12.

Paint Drum Bracket



Paint drums are heavy and could shift from side to side when the tow vehicle is cornering. The paint drums could fall from the vehicle and cause serious injury. Secure the drums when the vehicle is moving.

It is recommended that the paint drums be secured with a paint drum bracket. Graco does not provide a paint drum bracket with the Tow-Behind System.

Programmable Skipline Controller

The Programmable Skipline Controller must be installed in the cab of the tow vehicle. Select a position for ease of operation. This controller connects to the RoadPak with an I/O cable, so there must be cable access from the tow vehicle cab to the RoadPak. See manual 3A5387.

Hitch Receiver Kit: 238944 (Standard)

Installation Instructions for Hitch Kit 238944 (straight cross tube)

1 Torque to 220-240 ft-lb (298-325 N•m)

2 DRAW-TITE® Class IV Ultra-Frame tow hitch is not included. Cross tubes must be 3 in. x 3 in. (7.6 cm x 7.6 cm) square.

Ref.	Part	Description	Qty.
1	113665	SCREW, cap, hex head, grade 8; 5/8-11 unc-2a; 4.5 in. (11.4 cm)	6
2	113980	NUT, lock, hex, grade 8; 5/8-11 unc-2b	6

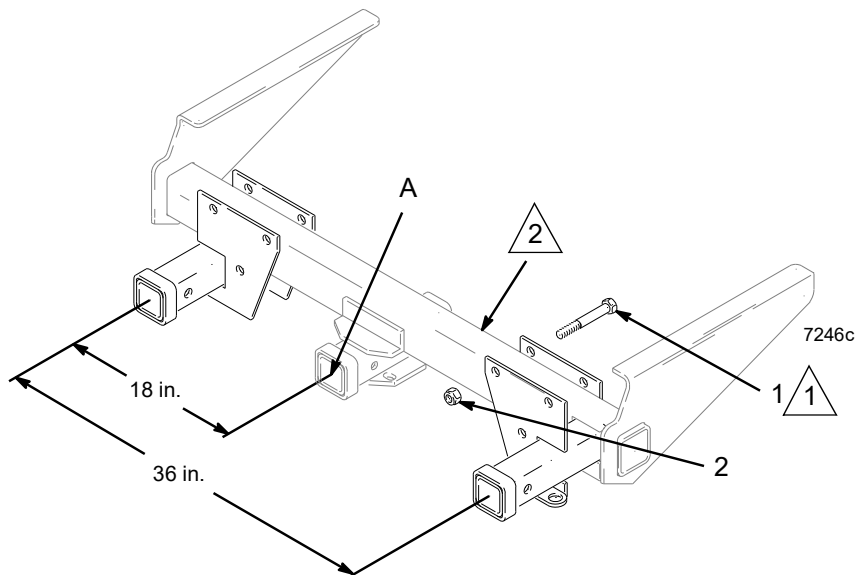

NOTE: For the nearest DRAW-TITE® installer call 1-800-428-7303

1. Have a DRAW-TITE® Class IV Ultra-Frame tow hitch (or equivalent hitch with a 7500 lb (3401 kg) GTW rating and 3 in. x 3 in. (7.6 cm x 7.6 cm) square cross tube) installed on your vehicle (reference DRAW-TITE® part no. series 419XXX).
2. Both of the Graco clamp-on receivers must be 18 in. from the center of the hitch frame (A).
3. Attach the left hitch receiver (3) to the trailer hitch with three of the supplied screws (1) and nuts (2).

NOTE: Pre-torque each of the screws to set the hitch receiver in place.

4. Repeating the process from step 2, attach the right hitch receiver (4) to the trailer hitch with the three remaining screws (1) and nuts (2).
5. Verify that the centers of the hitch receivers are 36 in. (91 cm) apart. Make any necessary adjustments.
6. Torque all of the screws to 220-240 ft-lb (298-325 N•m).

Hitch Receiver Kit: 239692 (Optional)

Installation Instructions for Hitch Kit 239692 (angled cross tube)

1 Torque to 220-240ft-lb (298-325 N•m)

2 DRAW-TITE® Class IV Ultra-Frame tow hitch is not included. Cross tubes must be 3 in. x 3 in. (7.6 cm x 7.6 cm) square

Ref.	Part	Description	Qty.
1	113665	SCREW, cap, hex head, grade 8; 5/8-11 unc-2a; 4.5 in. (11.4 cm)	6
2	113980	NUT, lock, hex, grade 8; 5/8-11 unc-2b	6

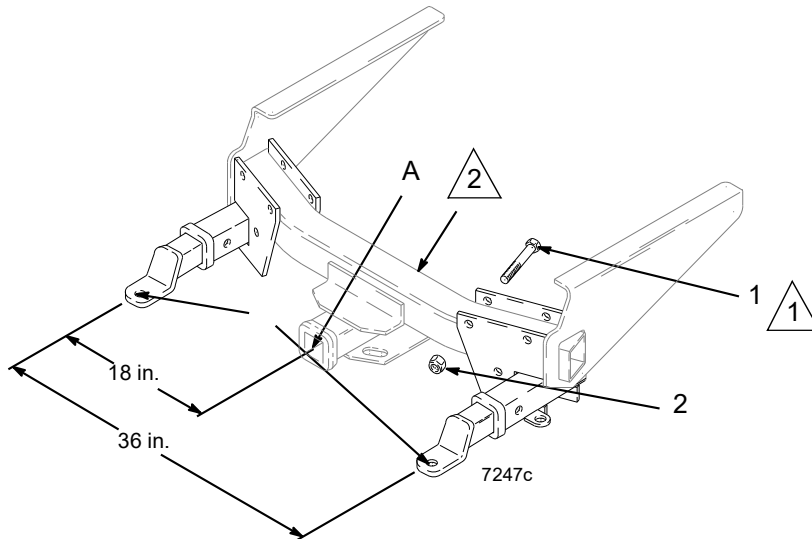

NOTE: For the nearest DRAW-TITE® installer call 1-800-428-7303

1. Have a DRAW-TITE® Class IV Ultra-Frame tow hitch (or equivalent hitch with a 7500 lb (3401 kg) GTW rating and 3 in. x 3 in. (7.6 cm x 7.6 cm) square cross tube) installed on your vehicle (reference DRAW-TITE® part no. series 419XXX).
2. Both of the Graco clamp-on receivers must be 18 in. from the center of the hitch frame (A).
3. Attach the left hitch receiver (3) to the trailer hitch with three of the supplied screws (1) and nuts (2).
4. Repeating the process from step 2, attach the right hitch receiver (4) to the trailer hitch with the three remaining screws (1) and nuts (2).
5. Verify that the centers of the hitch receivers are 36 in. apart. Make any necessary adjustments.
6. Torque all of the screws to 220-240 ft-lb (298-325 N•m).

NOTE: Pre-torque each of the screws to set the hitch receiver in place.

Setup

Charge Battery

If the battery is newly purchased or has not been used for a long time, charge it before you use it.

Grounding Instructions

1. Attach Tow-Behind System ground clamp to earth ground.

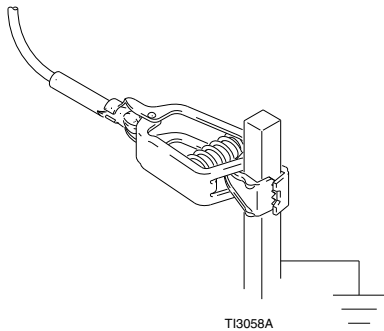

Level Draw Bar with Tow-Behind System

Use the following procedure to ensure level operation of the Tow-Behind System.

1. Empty tow vehicle of any payload.
2. Install draw bar to measure approximately 22 in. (56 cm) from top of ball mount to ground.

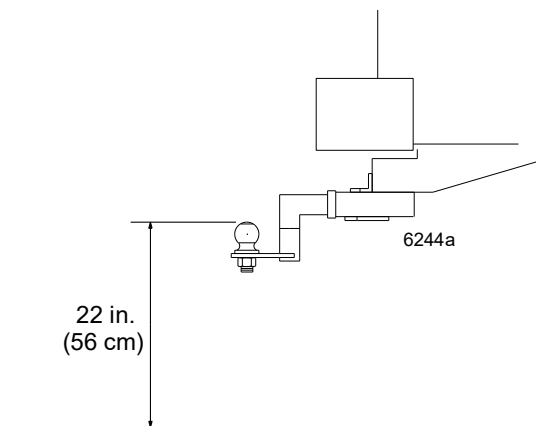

NOTE: For initial setup, leave trailer on supplied pallet until final step of **Connect Tow-Behind System to Vehicle** procedure.

Connect Tow-Behind to Vehicle

<p>If the wheels are not rotated to the rear of the trailer, it can become unstable and tip over if the tow vehicle is removed, causing serious injury.</p> <p>Only remove the Tow-Behind system from its tow vehicle when the wheels are facing the rear of the trailer and are blocked on both sides.</p>				
<p>ti18281a</p>		<p>ti18279a</p>		

1. Install two ball mounts in hitch receivers:
 - a. Slide ball mount into hitch receiver.

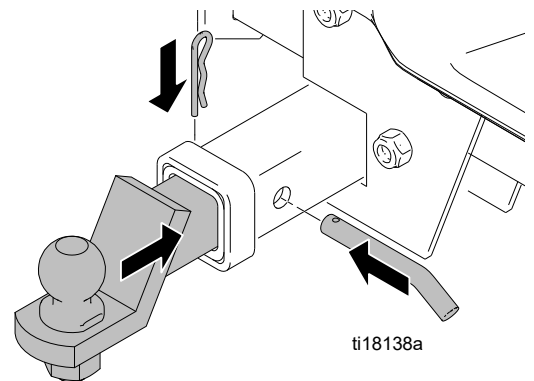

- b. Insert pin.
- c. Insert clip.

Setup

2. Connect trailer to ball mounts:

- a. Back tow vehicle into trailer and align ball mounts with trailer arms.
- b. Crank trailer arm jacks to clear ball mounts.

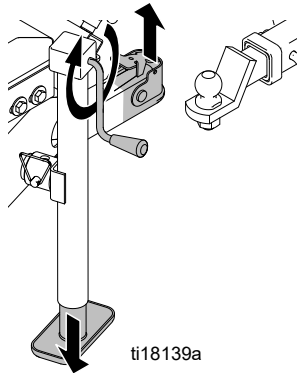

- c. Move tow vehicle backward and align ball mounts under trailer arms.
- d. Crank trailer arm jacks to lower RoadPak trailer arms onto ball mounts.

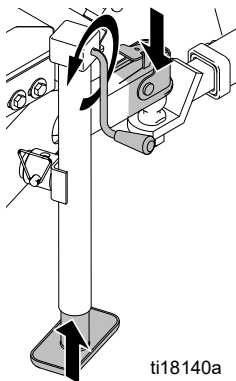

- e. Secure safety pins (A) for both trailer arm couplers and connect safety chains.
- f. Connect safety chains.

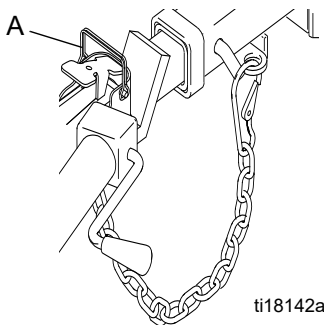

- g. Rotate jack to horizontal position. Insert safety pins into place to secure jacks.

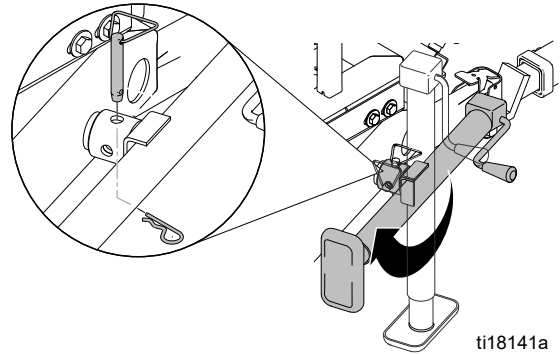

3. Shorten each safety chain:
 - a. Unscrew nut fastening chain to RoadLazer.
 - b. Refasten chain to RoadLazer so it connects to tow vehicle with minimum slack.
4. Connect wires for lights.
5. If trailer is still attached to shipping pallet, remove straps and tow trailer off of pallet.

Trailer Tires

Trailer tires can cause noticeable vibration when out of balance. For extended highway use Graco recommends adding 1 oz. of Dyna Beads® to each wheel. Dyna Beads and installation instructions can be found at: www.innovativebalancing.com.

Gun Arm Beam Bracket

1. Center Gun Arm Beam Bracket on trailer cross-member as shown and install supplied bolts and nuts as shown. Torque to 215-235 in-lb (24.3-26.5 N•m).

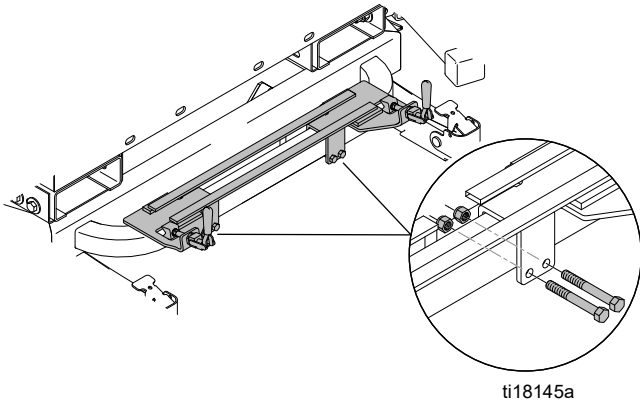



Gun Arm Stow Bracket

NOTE: Install Gun Arm Stow Bracket before mounting RoadPak to trailer.

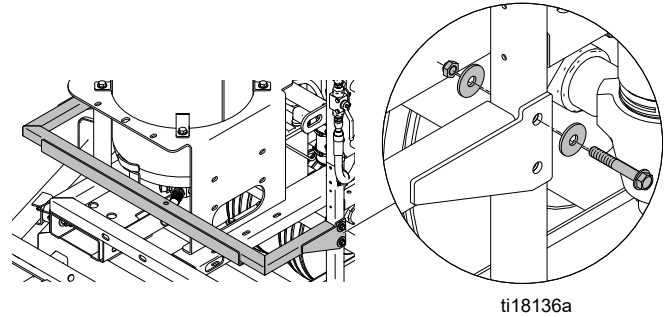
1. Align stow bracket with mounting holes.
2. Install and tighten four bolts and washers (use one washer on each side of each bolt). Torque bolts to 28 ft-lb (38 N•m).



Installing RoadLazer onto Trailer

				
<p>If RoadPak is not properly secured to trailer, it can fall off of trailer and cause serious injury.</p> <p>Use only Graco supplied fasteners and tighten them to the required torque. Use all of the fasteners provided.</p>				

NOTE: Only install RoadLazer onto trailer if trailer is properly attached to tow vehicle.

NOTE: Remove rear jack from trailer before mounting RoadPak.

NOTE: If tow vehicle is a pick-up, remove tailgate before installation.

Load RoadPak onto trailer using a forklift or a hoist that is rated for the weight of the RoadPak. For RoadPak weight information see **Technical Data**, page 41.

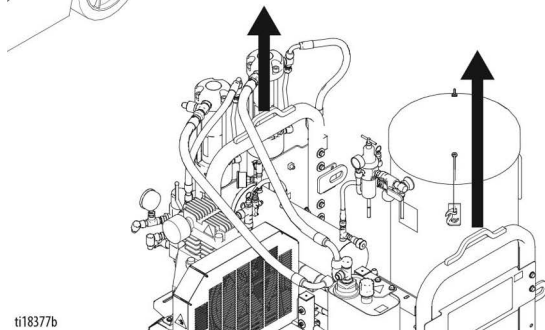
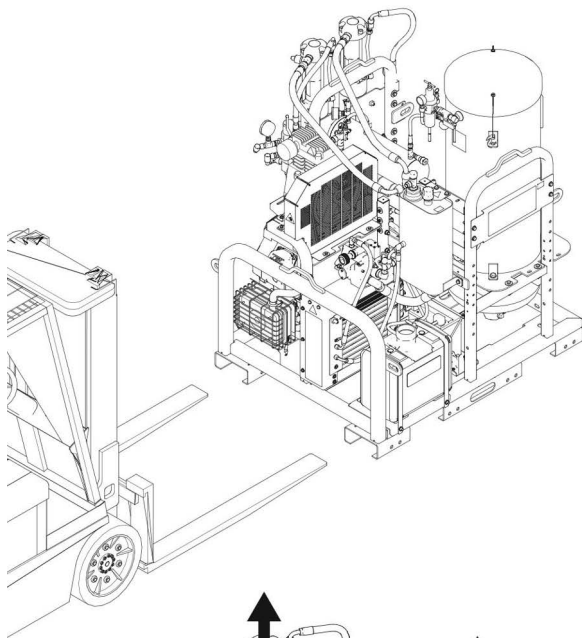

ti18377b

After loading the RoadPak on the trailer, secure the RoadPak to the trailer using the supplied bolts, nuts, and washers. Torque bolts to 28 ft-lb (38 N•m). Replace rear jack.

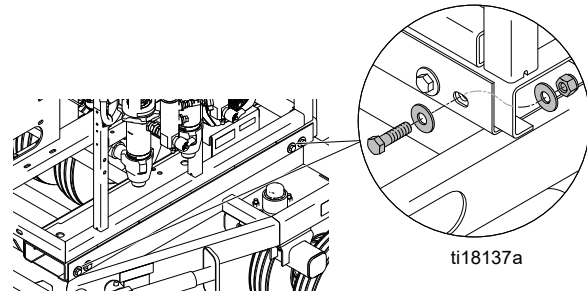

ti18137a

Adjustable Gun Arm Beam Installation (24G630)

The gun arm beam is shipped at 87.75 in. (2.2 m) long to accommodate wider vehicles. The beam can be cut down to 75.75 in. (1.9 m) long or 60 in. (1.5 m) long to accommodate different vehicle sizes.

1. To shorten the beam to 75.75 in. (2.2 m), cut 12 in. (30 cm) from the end of the beam towards the next hole on the beam. To shorten the beam to 60 in. (1.5 m), cut 27.75 in. (70 cm) from the end of the beam towards the third hole as shown below.

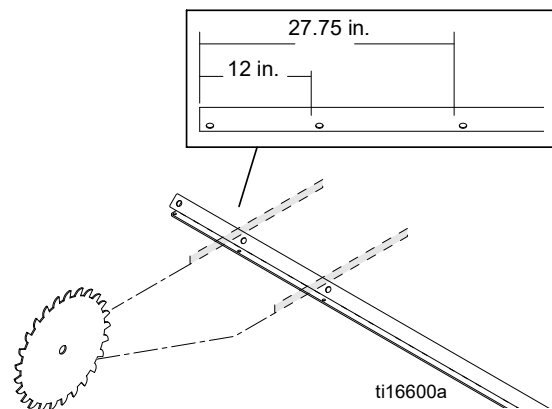

ti16600a

2. After shortening to the desired length, slide the beam into the channel in the gun arm beam bracket.

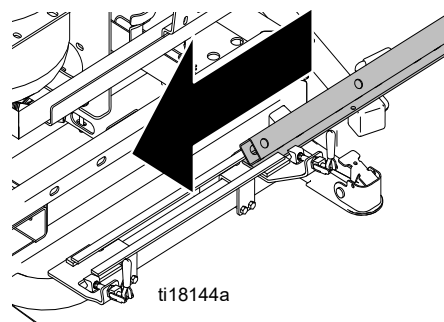

ti18144a

Adjustable Gun Arm Installation (25M708, 25M709)

1. Position the gun arm next to the vehicle.
2. Pull the gun arm beam out to the side of the vehicle where the gun arm is located. Lift the gun arm and hold the traverse bracket in the position shown below. Slide the beam through the wheels so they are mounted on the track of the gun arm beam as shown below.

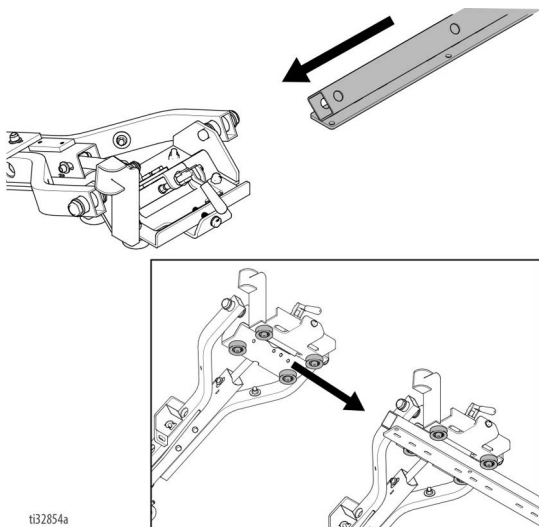

3. Attach the handle (704) to each end of the gun arm beam. Press the cotter pin (707) through the handle to hold it in place. Fasten nut (706) and bolt (705) through the slide beam on both ends to act as stops on the channel.

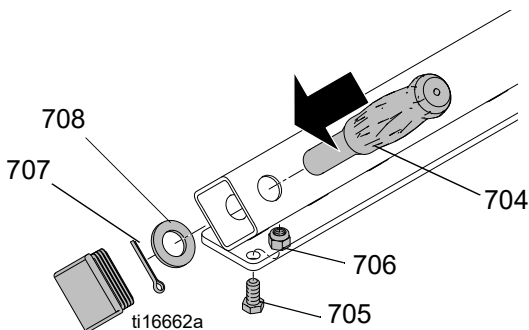

Install Safety Switch and Gun Arm Stow Plate



1. Remove two nuts and washers from safety switch bracket and remove from gun arm.

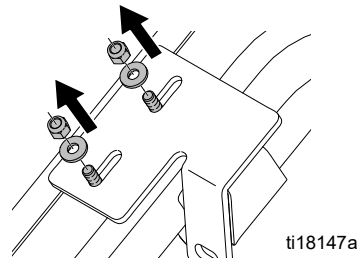

2. Disconnect two wires on safety switch and pull wires out of rectangular tube.

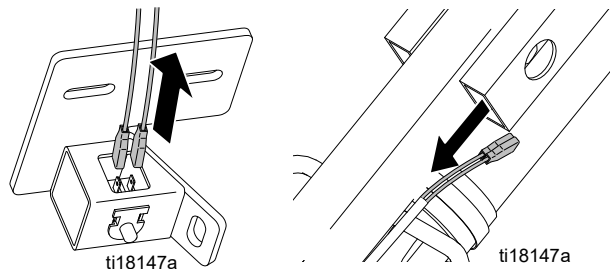

3. Reposition and install safety switch bracket as shown.

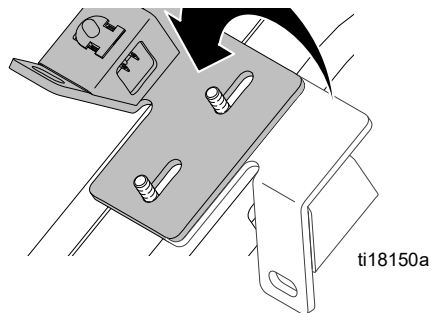

4. Install gun arm stow plate as shown.

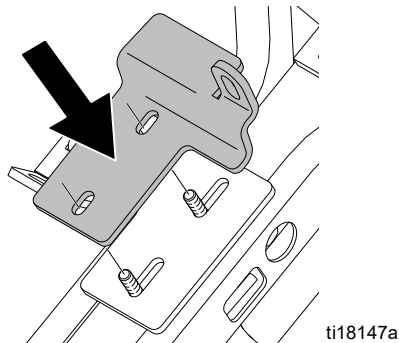

Setup

5. Hand-tighten two mounting nuts but allow enough movement to make slight adjustments once in place.

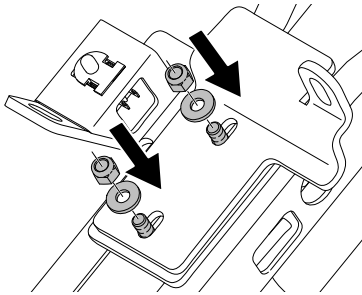

ti18148a

6. Connect safety switch wires.

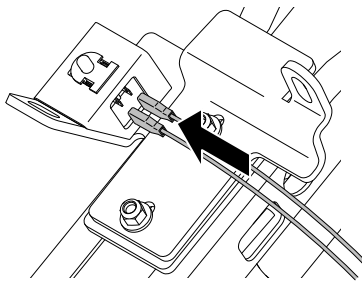

ti18152a

Use cable ties to secure wires to gun arm. System will not operate if wires become damaged.

7. Swing gun arm up and align stow plate in channel of stow bracket. Slide gun arm towards center of stow bracket until safety switch aligns with stow bracket as shown. **NOTE:** Be sure that the hose bundle does not become caught or pinched when moving gun arm.

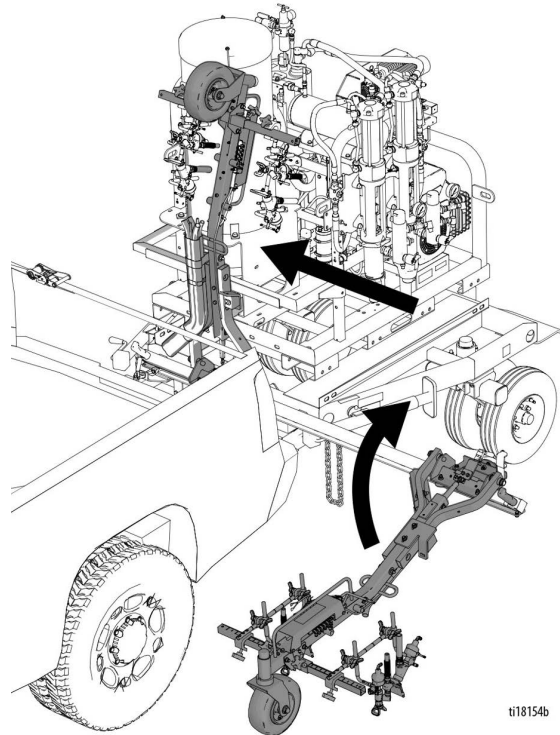

ti18154b

8. Measure gap between safety switch and stowing bracket. **NOTE:** If gap is less than 0 in. or greater than 3/16 in. (4.7 mm) use a mallet to tap stowing bracket to create a proper gap. Move safety switch away from this area when adjusting gap.

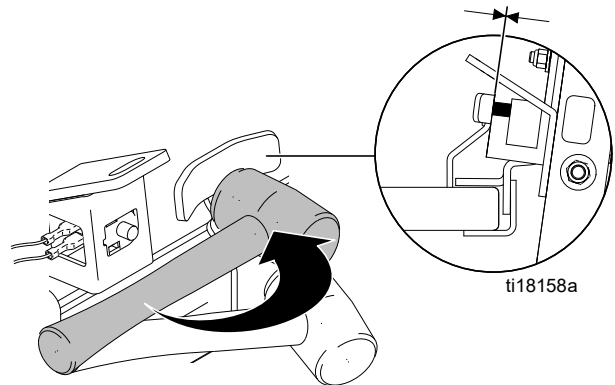

ti18158a

9. Align hole in stow bracket with slot in stow plate. install safety pin.

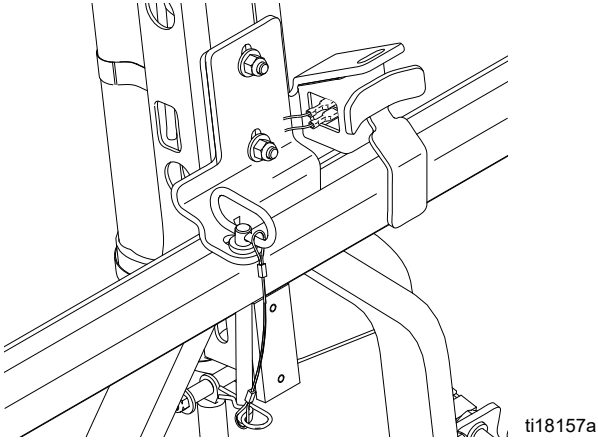

10. Align safety switch bracket so safety switch is aligned with stowing bracket as shown and tighten nuts.

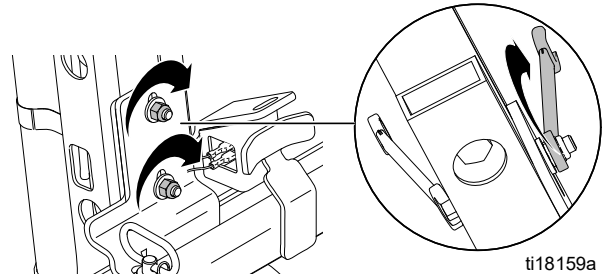

Hose Routing to Pumps and Tanks

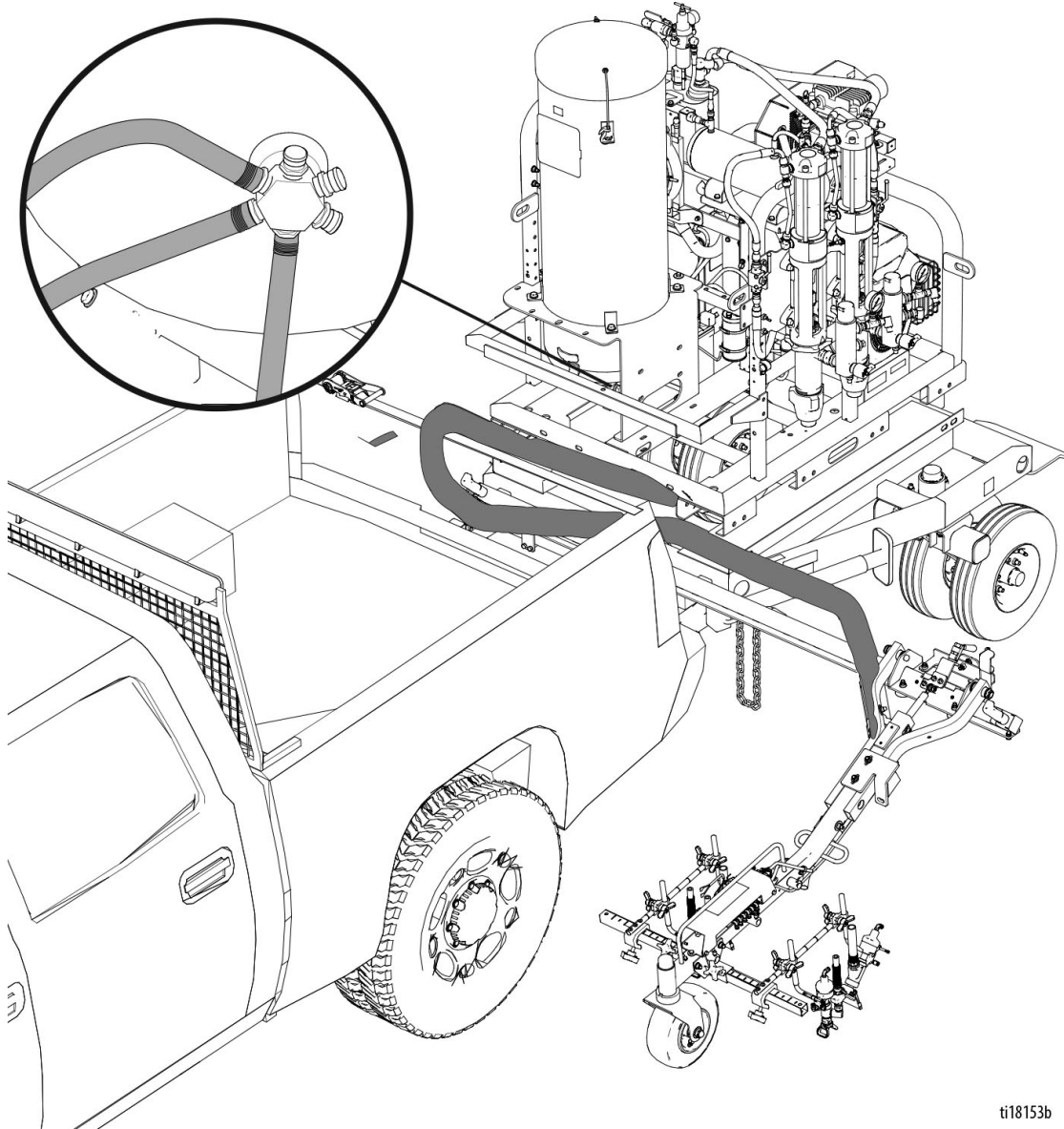

ti18153b

Filter Orientation

1. Use a hammer to loosen the large jam nut on the pump assembly.

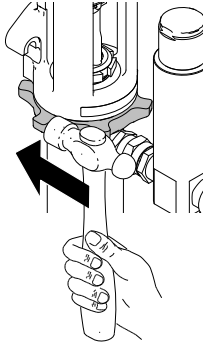

ti16782a

2. Rotate the filter assembly to the desired orientation and use a hammer to tighten the jam nut and lock the assembly into place.

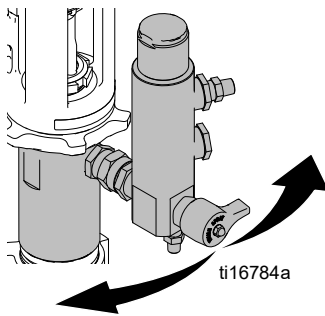

ti16784a

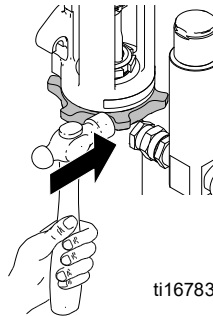

ti16783a

Hose Routing

Never allow hoses to touch the ground during operation. Damage to hoses will occur. Attach a tie-down strap across the truck bed and lay excess hose on top of the strap to suspend excess hose length.

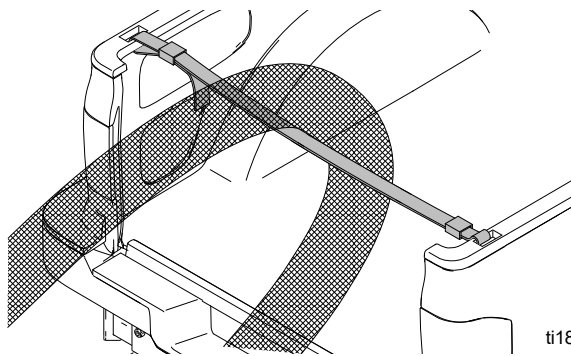

ti18151a

NOTE: If tow vehicle is a pick-up, remove tailgate.

1. Pull gun arm beam out to one side of the vehicle. Pull gun arm out and lower it to make sure the hose bundle has been secured at the proper location to ensure full movement for the gun arm to move from one side to the other. Make adjustments as needed.

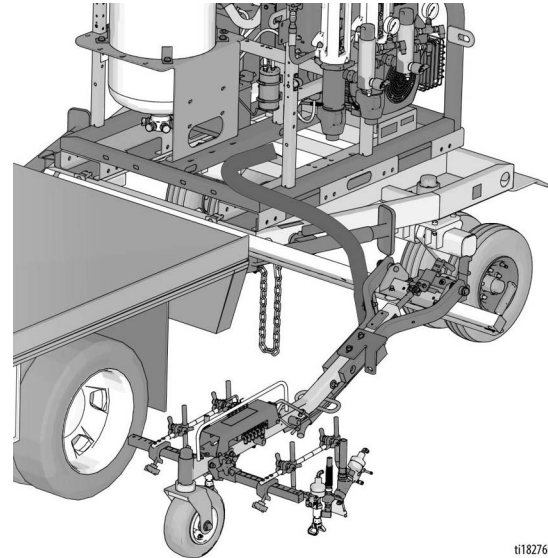

ti18276b

2. Lift gun arm back to the stow position. Pull gun arm beam out to other side of vehicle and pull the gun arm to that side to ensure the hose location is adequate for full movement.

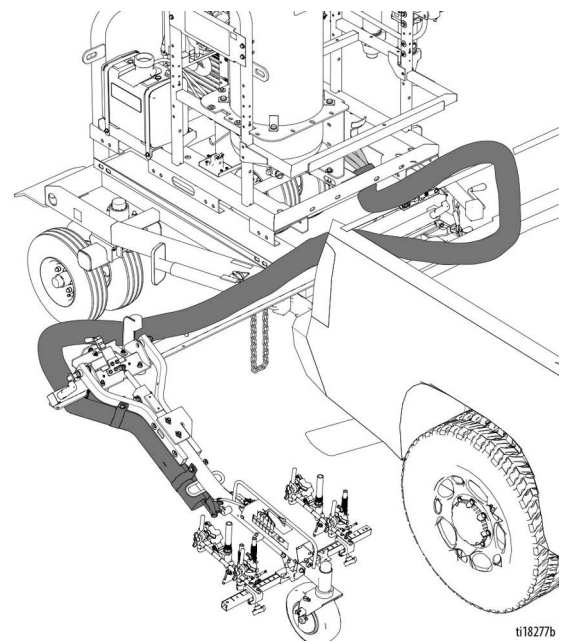

ti18277b

Setup

- Put gun arm back to the stow position and pin it into place. Center the gun arm beam to the vehicle. Lock the gun arm beam and gun arm into place by engaging the clamps for each.

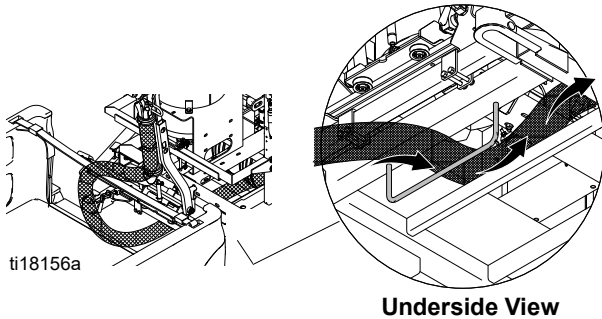

- Extend return line by adding extra hose length and fitting included in the siphon and drain hose extension kit. Install return line on the RPS 2900 filter assembly and route back to the paint drum.

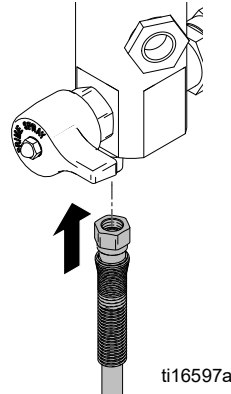

Hose Connection

- Modify suction hoses by loosening the hose clamps and separating the flexible hose from the bent siphon tube. Install barbed coupler and extension hose as shown.

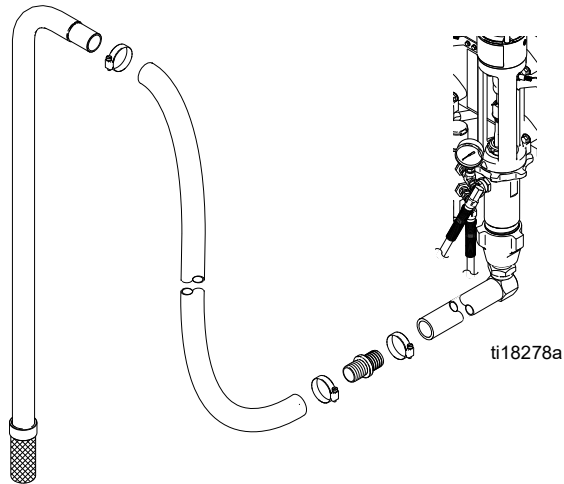

- Install paint lines to RPS 2900 filter assemblies. For a two color system, route the hose from paint gun 1 to pump 1 and route one hose from paint gun 2 to pump 1. Route the second hose from paint gun 2 to pump 2.

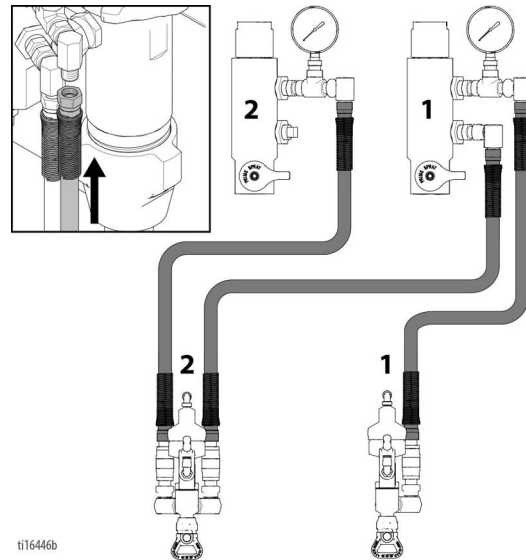

- Use supplied clamps to secure suction hose to each end of the barbed coupler and to bent siphon tube.
- Install modified suction tubes on the RPS 2900 pump and route to paint drum.

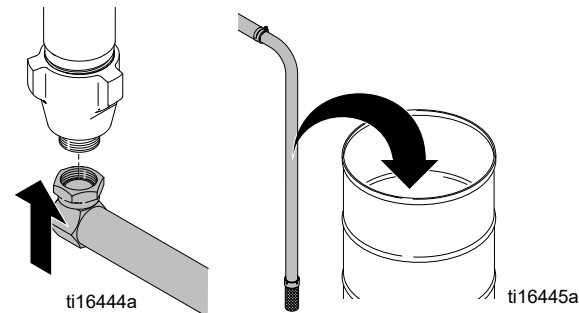

- Install bead lines to the bead tank.

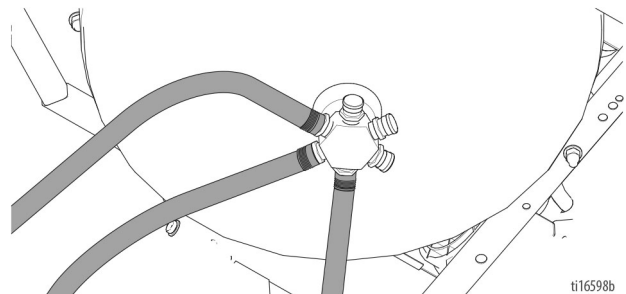

7. Install air hose to quick connect fitting on air tank.

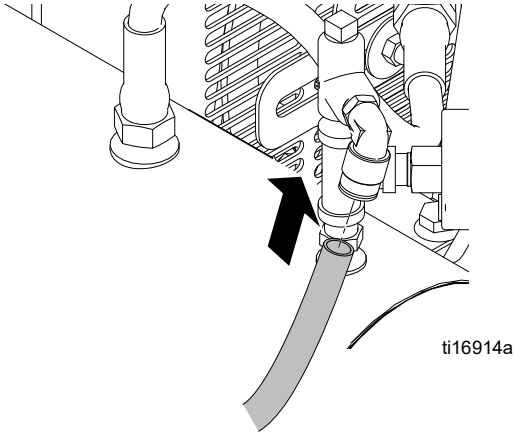

Electrical Cable Connections

1. Connect gun arm cable to the junction box. Fasten cable to cable clamp for strain relief (SR) on the connection.

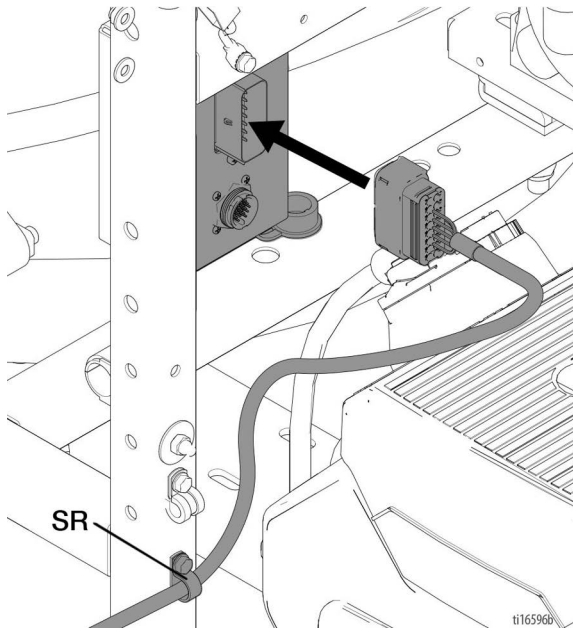

2. Connect control cable to the junction box. Fasten cable to cable clamp for strain relief (SR) on the connection.

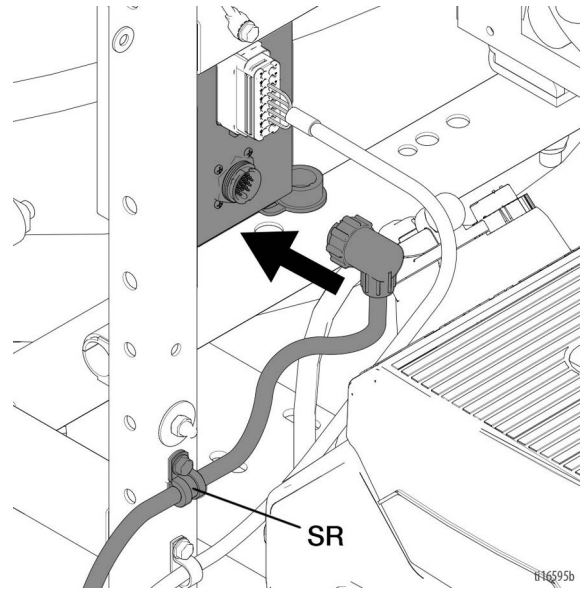

3. Route the control cable to the cab of the vehicle without pinching the cable. Connect the cable to the Programmable Skipline Controller.

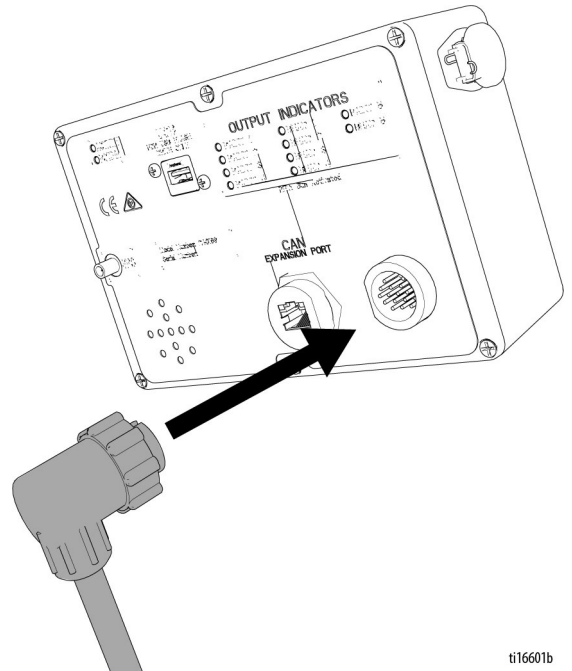

Wiring Diagram

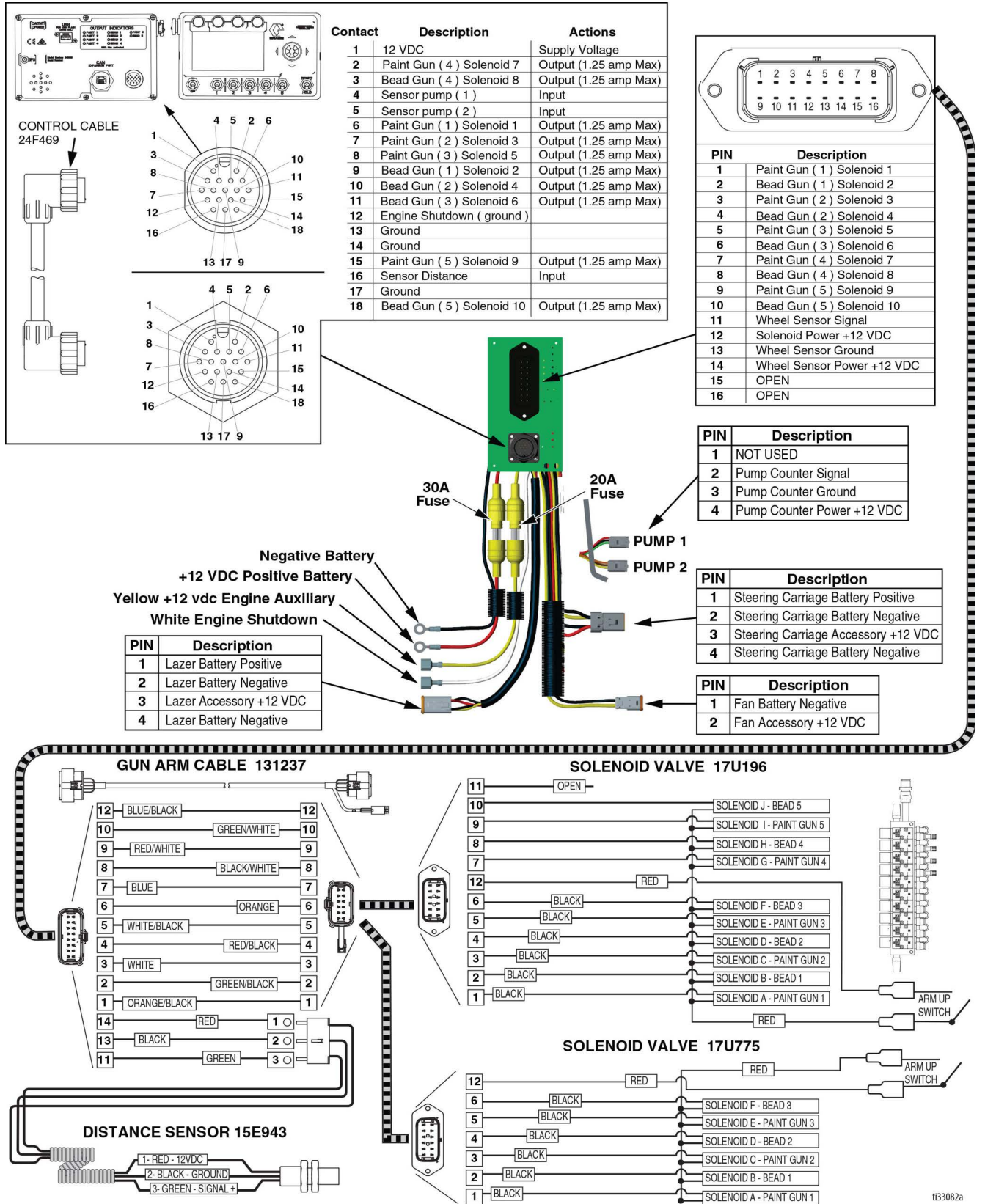

Contact	Description	Actions
1	12 VDC	Supply Voltage
2	Paint Gun (4) Solenoid 7	Output (1.25 amp Max)
3	Bead Gun (4) Solenoid 8	Output (1.25 amp Max)
4	Sensor pump (1)	Input
5	Sensor pump (2)	Input
6	Paint Gun (1) Solenoid 1	Output (1.25 amp Max)
7	Paint Gun (2) Solenoid 3	Output (1.25 amp Max)
8	Paint Gun (3) Solenoid 5	Output (1.25 amp Max)
9	Bead Gun (1) Solenoid 2	Output (1.25 amp Max)
10	Bead Gun (2) Solenoid 4	Output (1.25 amp Max)
11	Bead Gun (3) Solenoid 6	Output (1.25 amp Max)
12	Engine Shutdown (ground)	
13	Ground	
14	Ground	
15	Paint Gun (5) Solenoid 9	Output (1.25 amp Max)
16	Sensor Distance	Input
17	Ground	
18	Bead Gun (5) Solenoid 10	Output (1.25 amp Max)

PIN	Description
1	Paint Gun (1) Solenoid 1
2	Bead Gun (1) Solenoid 2
3	Paint Gun (2) Solenoid 3
4	Bead Gun (2) Solenoid 4
5	Paint Gun (3) Solenoid 5
6	Bead Gun (3) Solenoid 6
7	Paint Gun (4) Solenoid 7
8	Bead Gun (4) Solenoid 8
9	Paint Gun (5) Solenoid 9
10	Bead Gun (5) Solenoid 10
11	Wheel Sensor Signal
12	Solenoid Power +12 VDC
13	Wheel Sensor Ground
14	Wheel Sensor Power +12 VDC
15	OPEN
16	OPEN

PIN	Description
1	NOT USED
2	Pump Counter Signal
3	Pump Counter Ground
4	Pump Counter Power +12 VDC

PIN	Description
1	Steering Carriage Battery Positive
2	Steering Carriage Battery Negative
3	Steering Carriage Accessory +12 VDC
4	Steering Carriage Battery Negative

PIN	Description
1	Fan Battery Negative
2	Fan Accessory +12 VDC

PIN	Description
1	Lazer Battery Positive
2	Lazer Battery Negative
3	Lazer Accessory +12 VDC
4	Lazer Battery Negative

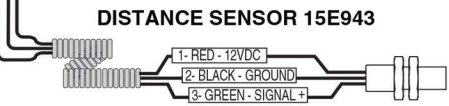
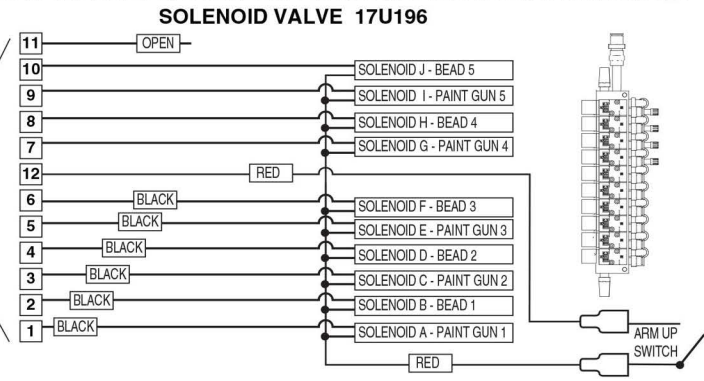
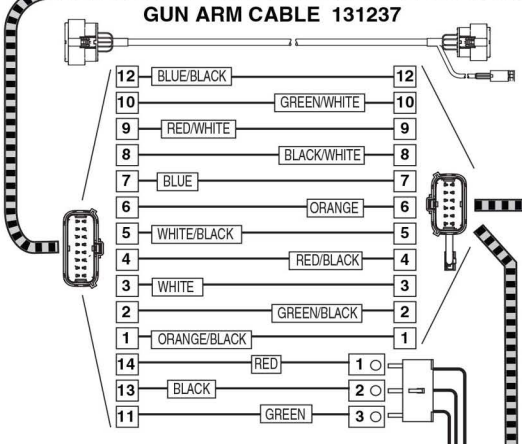

t133082a

Install Simple Guide System

1. Locate an area on the vehicle to mount the RoadPak pointer system that will allow the user to see the indicator rod from the driving position or with the help of the Road View Camera System.

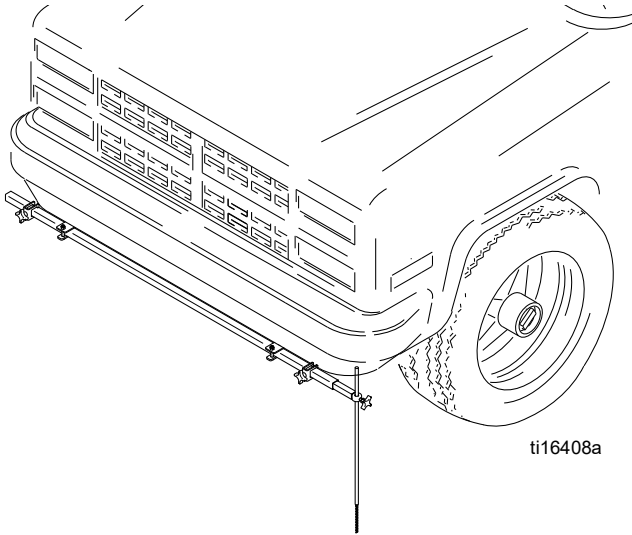

2. If needed, drill two 9/16 in. holes in the desired location.
3. Assemble mounting bracket (355) to desired location with bolt (359), washer (360), and nut (361).

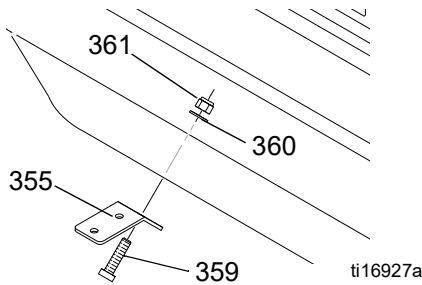

4. Hand tighten lock bar (356) to mounting bracket (355) with bolts (357) and nuts (358).

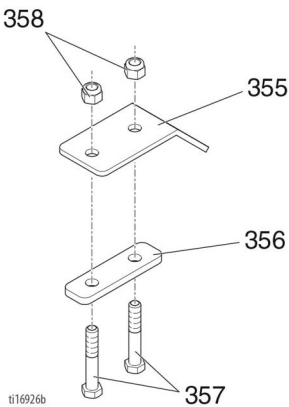

5. Slide support bar (351) through brackets (355) and tighten fasteners to secure in place.

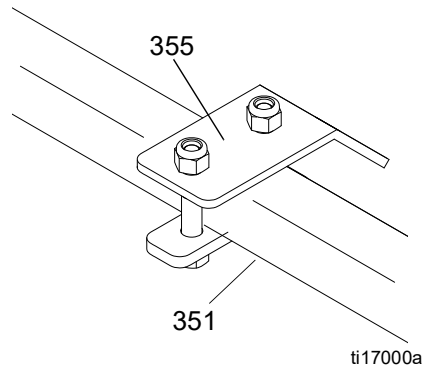

6. Assemble extension clamp to support bar.

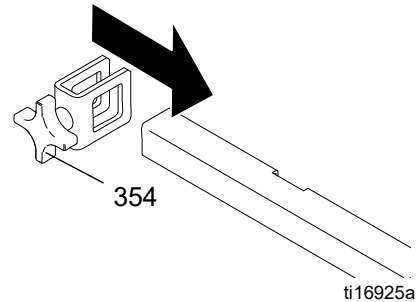

7. Insert indicator rod (362) into guide extension arm (352) and secure in place with knob (354).

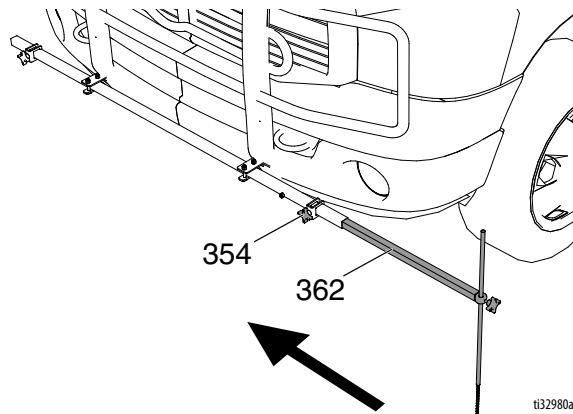



8. Adjust the indicator rod by loosening extension clamps and sliding the guide extension arm (352) to desired position. Secure by tightening knob (354).

Install and Align RoadView Camera System (Optional)

See RoadView Camera System manual.

Operation

Grounding



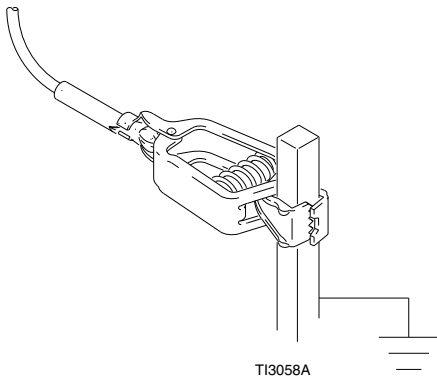

				
---	---	---	--	--

The equipment must be grounded to reduce the risk of static sparking. Static sparking can cause fumes to ignite or explode. Grounding provides an escape wire for the electric current.

1. Ground RoadLazer with grounding clamp to earth ground.



Pressure Relief Procedure

				
---	---	---	---	--

This equipment stays pressurized until pressure is manually relieved. To help prevent serious injury from pressurized fluid, such as skin injection, splashing fluid and moving parts, follow Pressure Relief Procedure when you stop spraying and before cleaning, checking, or servicing the equipment.

RPS 2900 Pump Fluid Pressure Relief

1. Set hydraulic valve to OFF position.

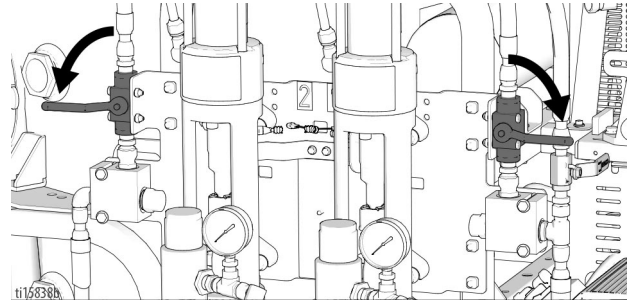

2. Run engine at half throttle.
3. Place empty pail under paint guns to catch drainage.
4. Relieve hose pressure through guns. Use Programmable Skipline Controller to trigger each gun for at least 3 seconds each.

NOTICE
Always relieve pressure with the guns, not with the filter drain valves. Using the filter drain valves can cause damage, and prevent them from sealing in the close/spray positions.

Operation

5. Close paint gun ball valves.

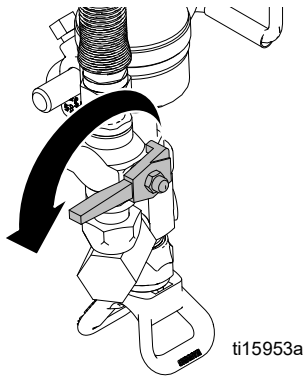

6. Open all drain valves, one at a time.
7. Close valves immediately to prevent paint from drying in system.
8. If you suspect the spray tip or hose is clogged or that pressure has not been fully relieved:
 - a. VERY SLOWLY loosen the tip guard retaining nut or the hose end coupling and relieve pressure gradually.
 - b. Loosen the nut or the coupling completely.
 - c. Clear the obstruction in the hose or tip.

Bead System Pressure Relief

1. Relieve air pressure in bead tank by turning bead system valve to OFF position.

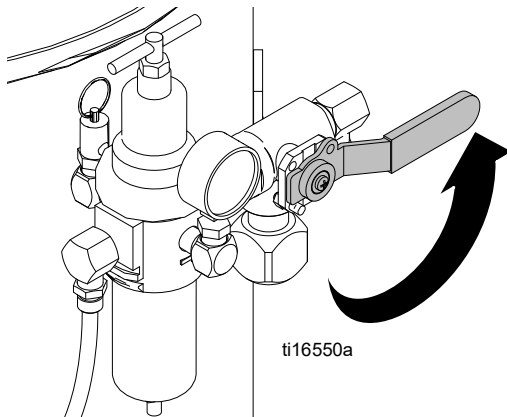

Air System Pressure Relief

1. Relieve air pressure in air tank by turning air valve to OPEN position.

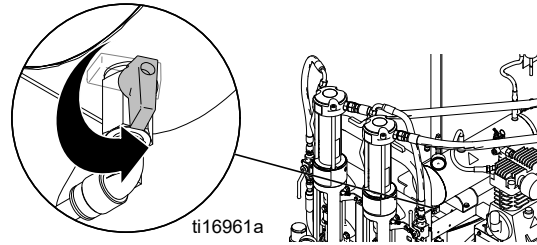

EMERGENCY SHUT OFF

To shut down the entire Tow-Behind system, set POWER ON/OFF on the Programmable Skipline Controller to the OFF position.

Load Reflecting Materials

1. Set POWER ON/OFF on Programmable Skipline Controller to OFF.
2. Set RoadLazer engine ignition key to OFF.
3. Relieve air system pressure by opening ball valve on the air tank until gauge reads 0.
4. Relieve air pressure in bead tank by turning bead system valve to OFF position.
5. Remove cover from bead tank.
6. Screen reflective materials to prevent debris from entering tank.
7. Turn T-handle counterclockwise to open bead fill port.
8. Load bead tank with reflective materials.
9. Once filled, turn T-handle clockwise, and place cover on tank.

Set Up Slide Beam and Gun Arm

1. Unlock gun arm clamp and the slide beam clamps.

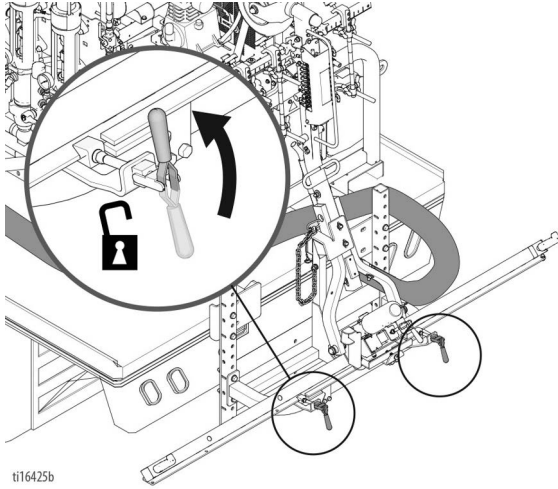

t116425b

2. Pull slide beam to left or right side of vehicle. Lock the slide beam clamps.
3. Remove gun arm from upright stowed position, and slide to end of boom. Slowly lower gun arm, and lock into position with clamp.

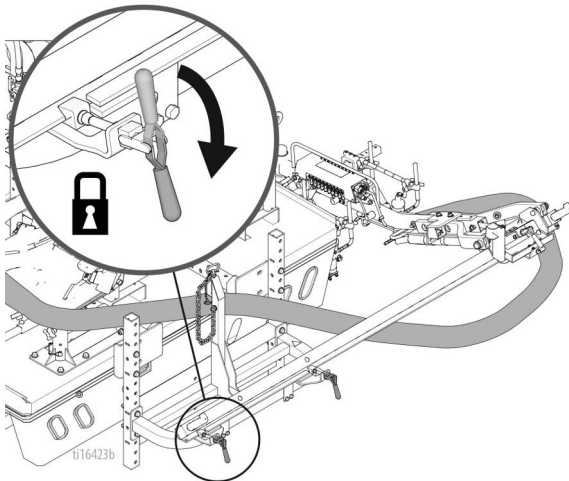

t116423b

Prepare System to Paint

NOTICE

Paint could splash from the paint drum bung adapters when the paint drums are full and the vehicle is moving. Do not overfill the paint drums.

Initial Settings

1. Ground RoadLazer with grounding clamp to earth ground. See **Pressure Relief Procedure**, page 27.
2. Fill throat packing nut with TSL to prevent premature packing wear. **Do this each time you spray and store.**

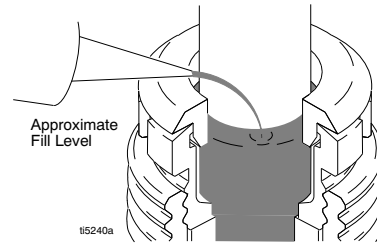

t115240a

3. Check engine oil level when engine is cold. If necessary, add appropriate oil for air temperature at time of operation.

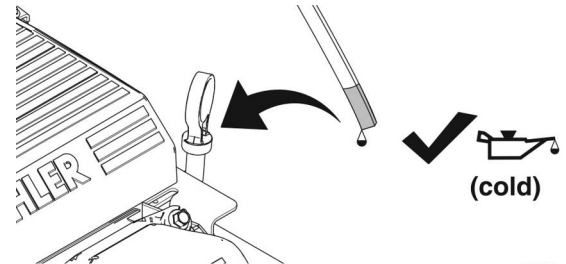

t116447b

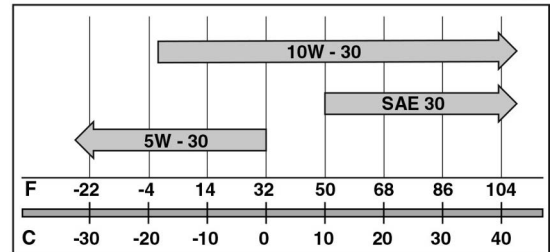

NOTICE

Engine can be started with low oil and may not shut off when low oil is detected. Damage may occur if oil is not at appropriate level before starting and while running equipment.

Operation

4. Fill fuel tank.
5. Check hydraulic oil level. Add only synthetic Hydraulic Oil, ISO 46 with a viscosity index (VI) of 154 or higher. Hydraulic tank capacity is approximately 4.0 gallons (15.14 liters).



6. Check oil level in compressor. **NOTE:** If red dot is visible, add SAE 30W non-detergent air compressor oil.

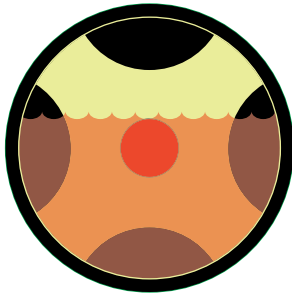

7. Verify all hose/fitting connections are tight.
8. Turn paint pump hydraulic valves to OFF (closed) position, and bypass valve to START position.

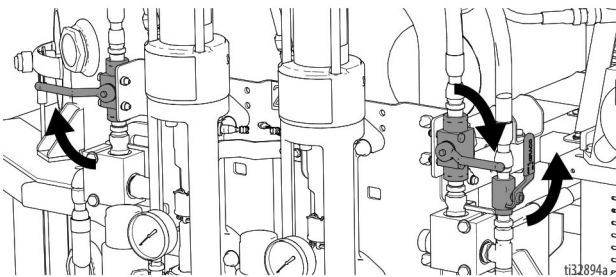

9. Turn valve lever by guns clockwise 1/4 turn to OFF position.

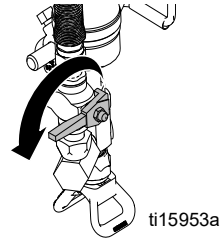

10. Place suction tube and drain tube in grounded metal pail partially filled with flushing fluid. Attach ground wire to pail and to earth ground.

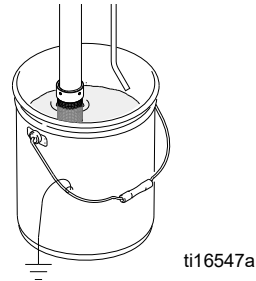

11. Turn prime/spray valve down.

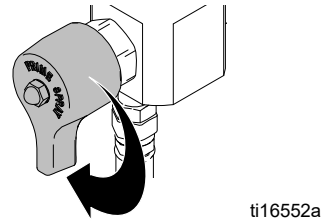

12. Install clean inlet strainer.

NOTE: There must be a minimum of 0.5 in. between bottom of strainer and suction tube.

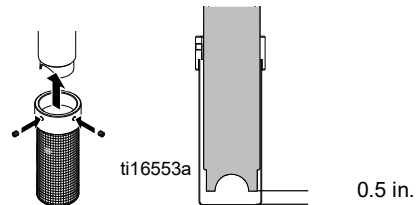

13. Turn pressure control counterclockwise to lowest pressure.

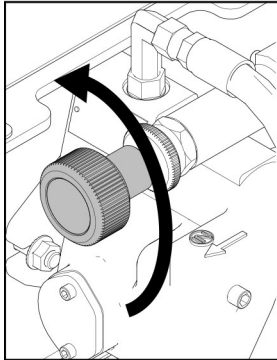

Start Engine

1. Set POWER ON/OFF on Programmable Skipline Controller to ON.
2. Set engine choke to ON position.
3. Set throttle to half speed and turn key.

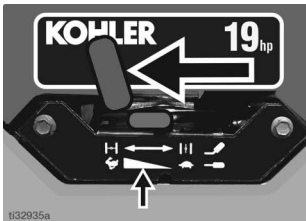

4. After engine starts, set choke to OFF.

Select/Prime Pumps

1. Turn the bypass valve to RUN and open hydraulic valve(s) to activate pumps.

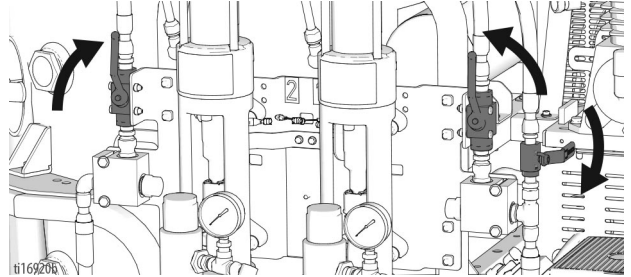

2. Slowly turn pressure control clockwise until pump begins to stroke.

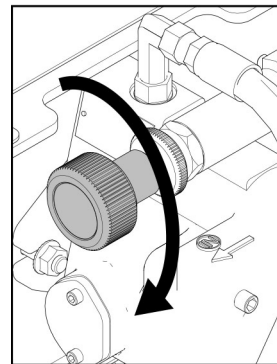

3. When flushing fluid comes out of return lines, set hydraulic valve to OFF position.

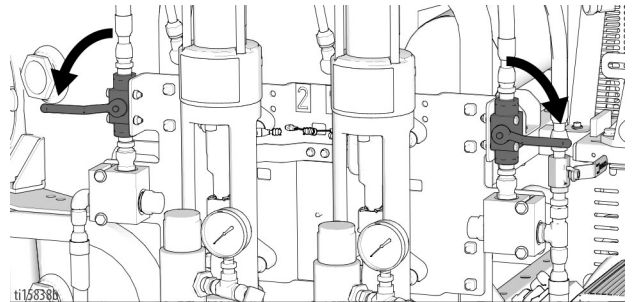

Operation

- Place suction hoses in paint drums.

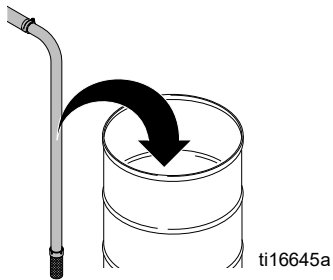

- Open hydraulic valve(s) to activate pumps.

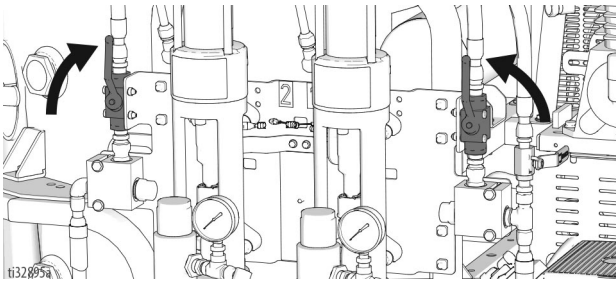

- When paint comes out of return lines, set hydraulic valve to OFF position.
- Turn all drain valves to the SPRAY (closed) position.

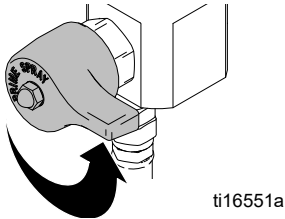

- Place return lines into paint drum.

Prime Guns

- Close air valve to pressurize air system.

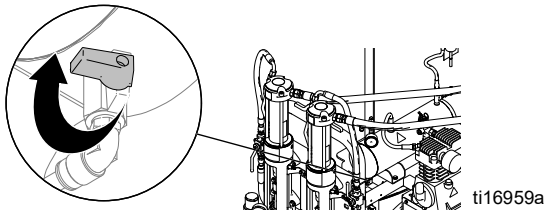

- Only open the spray gun ball valves corresponding to paint pumps and/or color to be used.

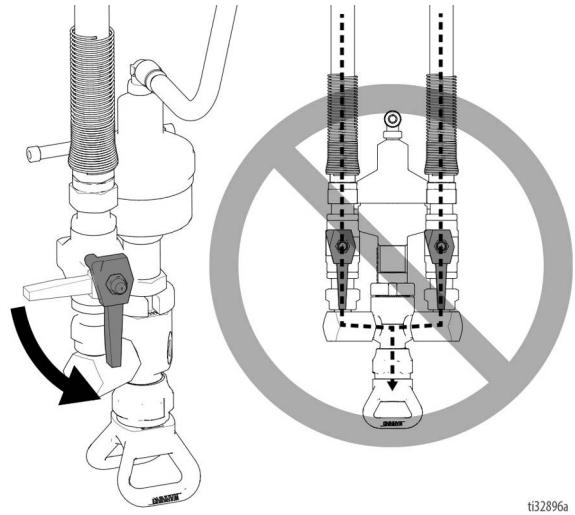

NOTE: Never open both ball valves on the two-color gun at the same time. Paint color contamination could result.

- Place an empty pail under spray guns to catch drainage from spray guns.
- Turn guns on with Programmable Skipline Controller (see Skipline Controller manual).
- Open hydraulic valve(s) to activate pumps.

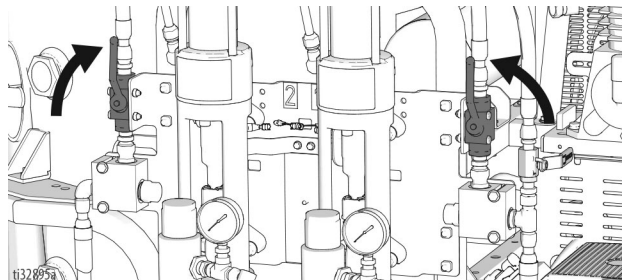

- Turn off guns with Programmable Skipline Controller.

Turn on Bead System

1. To pressurize the bead tanks, turn bead system valve to ON position.

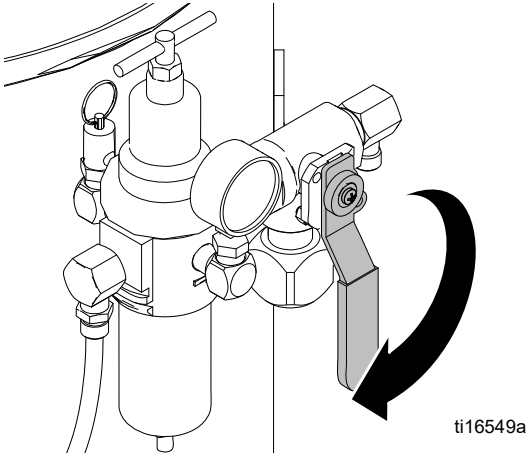

2. Set desired bead tank pressure by turning regulator knob.

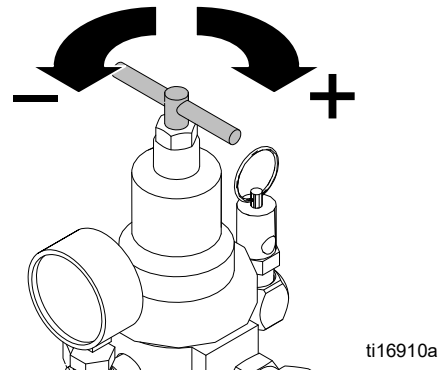

3. Remove and secure ground strap from earth ground.
4. System is now ready for painting. Select guns with the Programmable Skipline Controller.

Begin to Spray

Select appropriate procedure from menu on RoadLazer control system. See Skipline Controller manual.

Flush the System



The grounding clamp and ground strap are both required for safe operation. The grounding clamp is for stationary use.

1. Perform **Pressure Relief Procedure**, page 27.
2. Flush the system with compatible solvent. Check the system under pressure for leaks. If any are found, **relieve the pressure**, and repair the leaks. Pressurize the system again, and check for leaks.
3. Ground RoadLazer with grounding clamp to earth ground. See **Pressure Relief Procedure**, page 27
4. Set paint pump hydraulic valve(s) to OFF (closed) position.

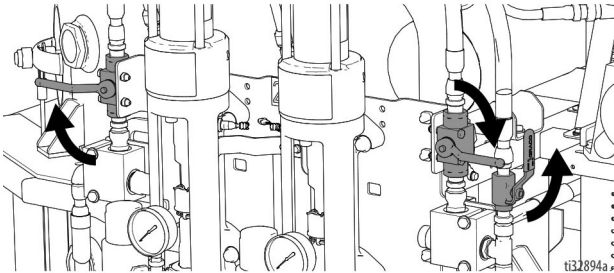

5. Fill a 5-gallon pail with water or compatible solvent. Place paint suction hose in pail.
6. Place paint return lines in empty pail.
7. Turn all prime/spray valve to the PRIME (open) position.

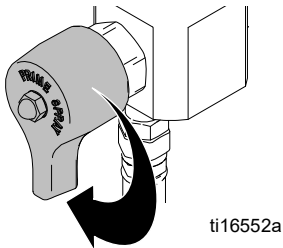

8. Turn on Programmable Skipline Controller.

NOTE: Unit will not start until Controller is turned ON.

9. Start Engine as follows:
 - a. Set Choke ON.
 - b. Set throttle to half speed.
 - c. Turn key.
 - d. After engine starts, set choke to OFF.



FIRE AND EXPLOSION HAZARD

To reduce the risk of static sparking and splashing, always remove the spray tip from the gun, and hold a metal part of the gun firmly to the side of a grounded metal pail during flushing.

10. Turn the bypass valve to RUN (closed), and open hydraulic valve(s) to activate pumps.

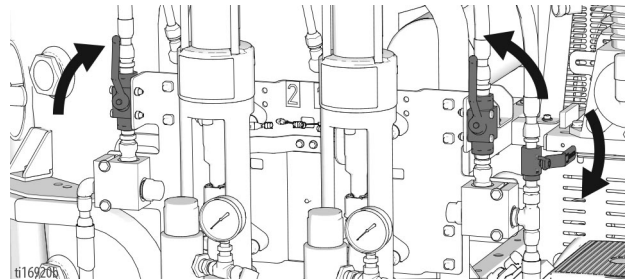

11. When water/solvent comes out of spray gun(s), set paint pump hydraulic valve(s) to OFF position.
12. Turn all prime/spray valves to the SPRAY (closed) position.

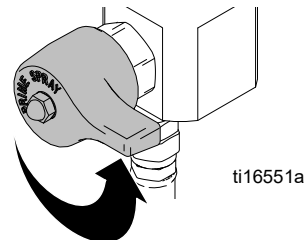

13. Only open spray gun ball valves corresponding to paint pumps or color used.

NOTE: Never open both valves on the two-color gun at the same time. Paint color contamination could result.

14. Place empty pail under spray guns to catch drainage from spray guns.
15. Turn guns on with Programmable Skipline Controller.
16. Turn the bypass valve to RUN (closed), and open hydraulic valve(s) to activate pumps.

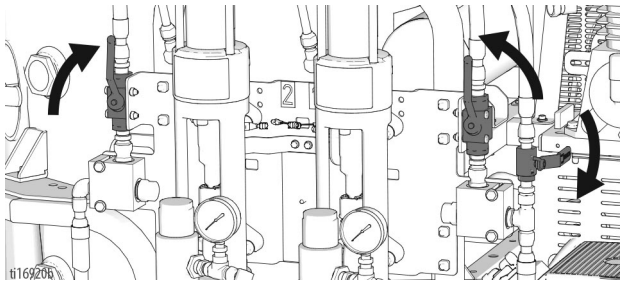

17. When water/solvent comes out of spray gun(s), set paint pump hydraulic valve(s) to OFF position.
18. Turn off guns with Programmable Skipline Controller.
19. Shut off engine and Programmable Skipline Controller.
20. Leave paint pump prime/spray valve(s) and spray gun ball valve(s) open.
21. Remove and secure ground clamp from earth ground.

Securing Gun Arm for Transportation

Never transport the RoadLazer while the paint gun ball valves are open, the system is under pressure, and/or the engine is running, as this could cause damage to components.

1. Unlock red-handled clamp to allow gun arm to move along slide beam.

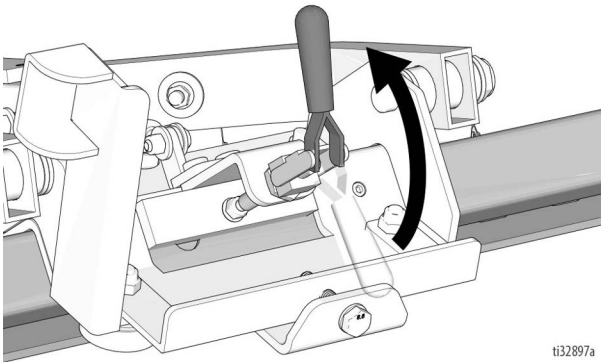

2. Lift gun arm up from ground, and push in to center of Tow-Behind System.

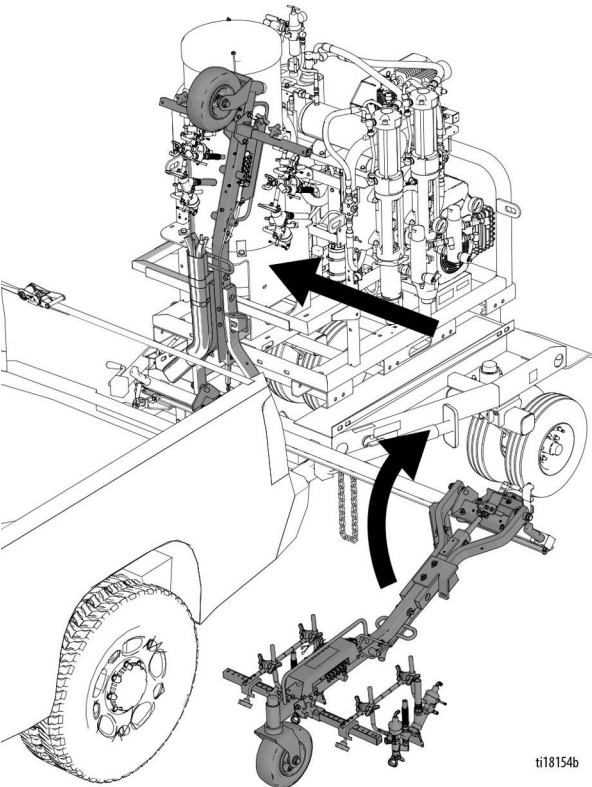

3. Put stow bracket pin through gun arm stowing bracket and plate. Secure with attached clip.

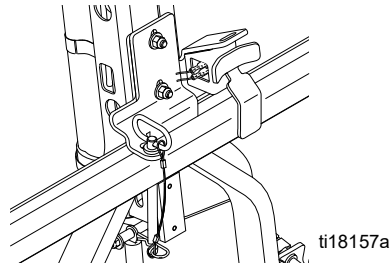

4. Unlock two red-handled clamps and center the gun arm beam on the trailer.

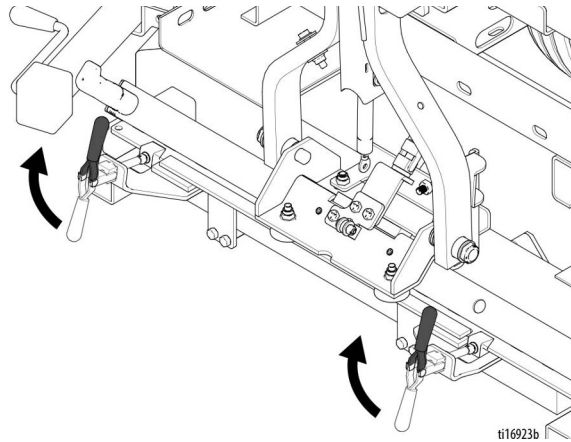

5. Lock three red-handle clamps to secure the slide beam and gun arm.

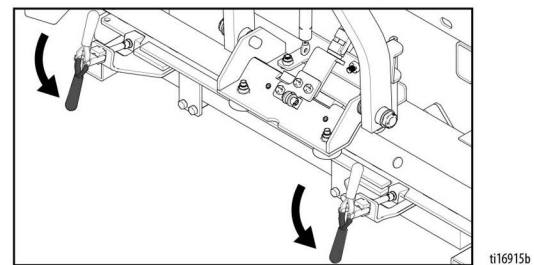
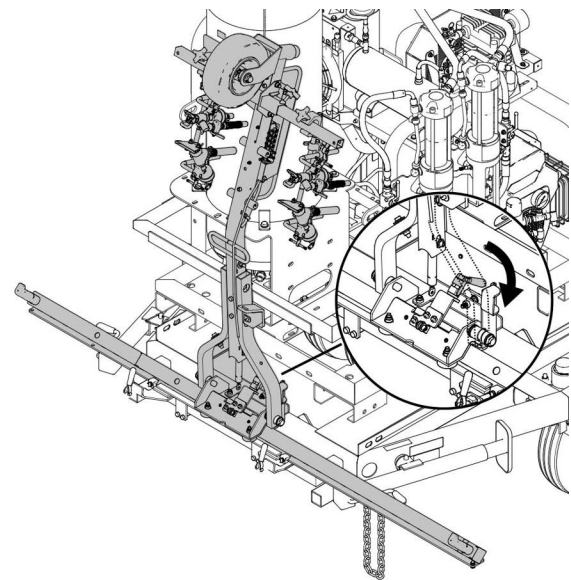

Removing RoadLazer from Vehicle



A free-standing RoadLazer RoadPak Tow-Behind System could become unstable when being moved without a tow vehicle, causing serious injury.

To reduce the risk of injury and equipment damage, never move Tow-Behind System without it being properly secured to a tow vehicle.

If the wheels are not rotated to the back of the trailer, it can become unstable and tip over if the tow vehicle is removed.

Never remove the Tow-Behind RoadLazer RoadPak from its tow vehicle if the wheels are not facing the rear of the trailer.

1. Park on level concrete surface where Tow-Behind System is intended to be parked.

NOTE: Make sure trailer wheels are at the far rear of the trailer as shown. If parking the trailer with wheels in this orientation is not possible, use rear jack to lift tires and rotate wheels into their correct orientation, then lower to ground.

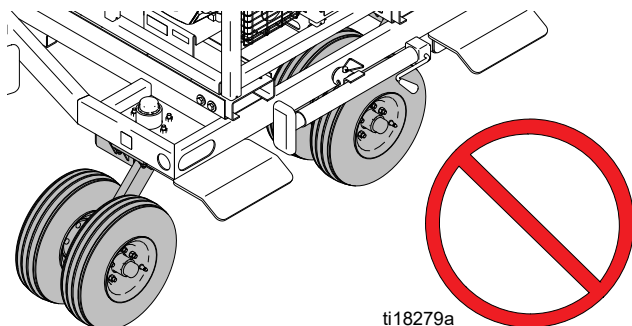
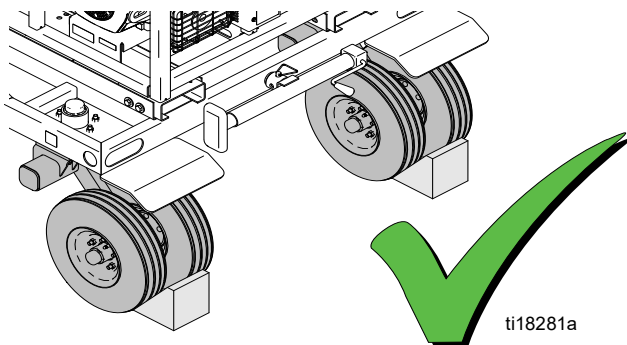

2. Block trailer wheels.
3. Disconnect Programmable Skipline Controller, trailer lighting, suction tubes, return lines, and any straps that connect RoadLazer or its hose assemblies to the tow vehicle. Do not disconnect safety chains.
4. Remove safety pins and rotate two side jacks and rear jack to vertical position. Replace safety pins to secure jacks.
5. Crank rear jack until jack foot plate touches the ground. Crank jack 5 more times to help stabilize trailer while in storage. Make sure wheels do not leave the ground. If wheels leave the ground, lower jacks until all trailer wheels are in contact with the ground.
6. Unlatch ball couplers and crank side jacks to raise trailer arms from ball mounts.



NOTE: Crank jacks sequentially (3 - 4 turns per side) to ensure the trailer arms are lifted evenly, keeping the trailer stable.
7. Disconnect safety chains.
8. Move tow vehicle forward to clear ball mounts. If all connections between vehicle and trailer have been removed, the tow vehicle can be removed from the trailer.
9. Crank jacks down equally to bring Tow-Behind System to level position for storage.
10. Always use rear jack during storage to provide additional stability.

Repair

Trailer Tire

NOTE: Replace trailer tire when damaged. or tread on tire is 3/32 in. (2.4 mm) or less.

Trailer Tire Replacement

				
<p>A free-standing Tow-Behind System could become unstable and fall when raised by the jack, causing serious injury.</p> <p>To reduce the risk of injury and equipment damage:</p> <ul style="list-style-type: none">• Connect Tow-Behind System to tow vehicle before raising with jack. <p>Follow Connect Tow-Behind to Vehicle instructions, page 13.</p>				

1. Connect Tow-Behind System to tow vehicle.

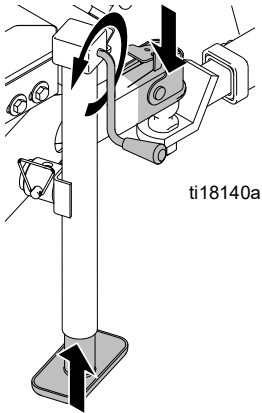

2. Rotate rear jack to vertical position and install safety pin to secure jack.

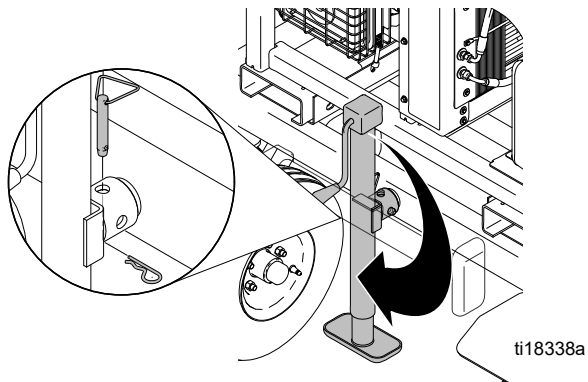

3. Crank jack to lift Tow-Behind System wheels off the ground.

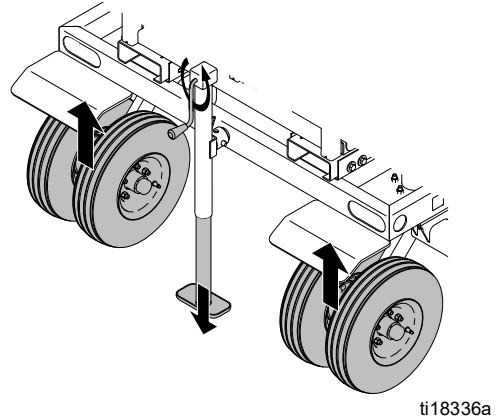

4. Remove lug nuts and wheel.

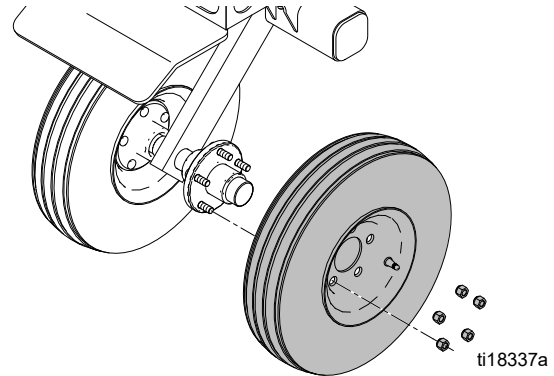

NOTE: Any service station can repair a Tow-Behind System flat tire.

5. Install new wheel and lug nuts. Torque lug nuts to 90-120 ft-lb (122-163 N•m).

NOTE: Replace lug nuts in same orientation as when they were removed.

NOTE: If not replacing all tires, be sure new tires are from the same manufacturer as existing tires to ensure consistent size.

General Trailer Service

For any other trailer-specific service needs, contact Graco Technical Service or a certified manufacturer/service center.

Parts

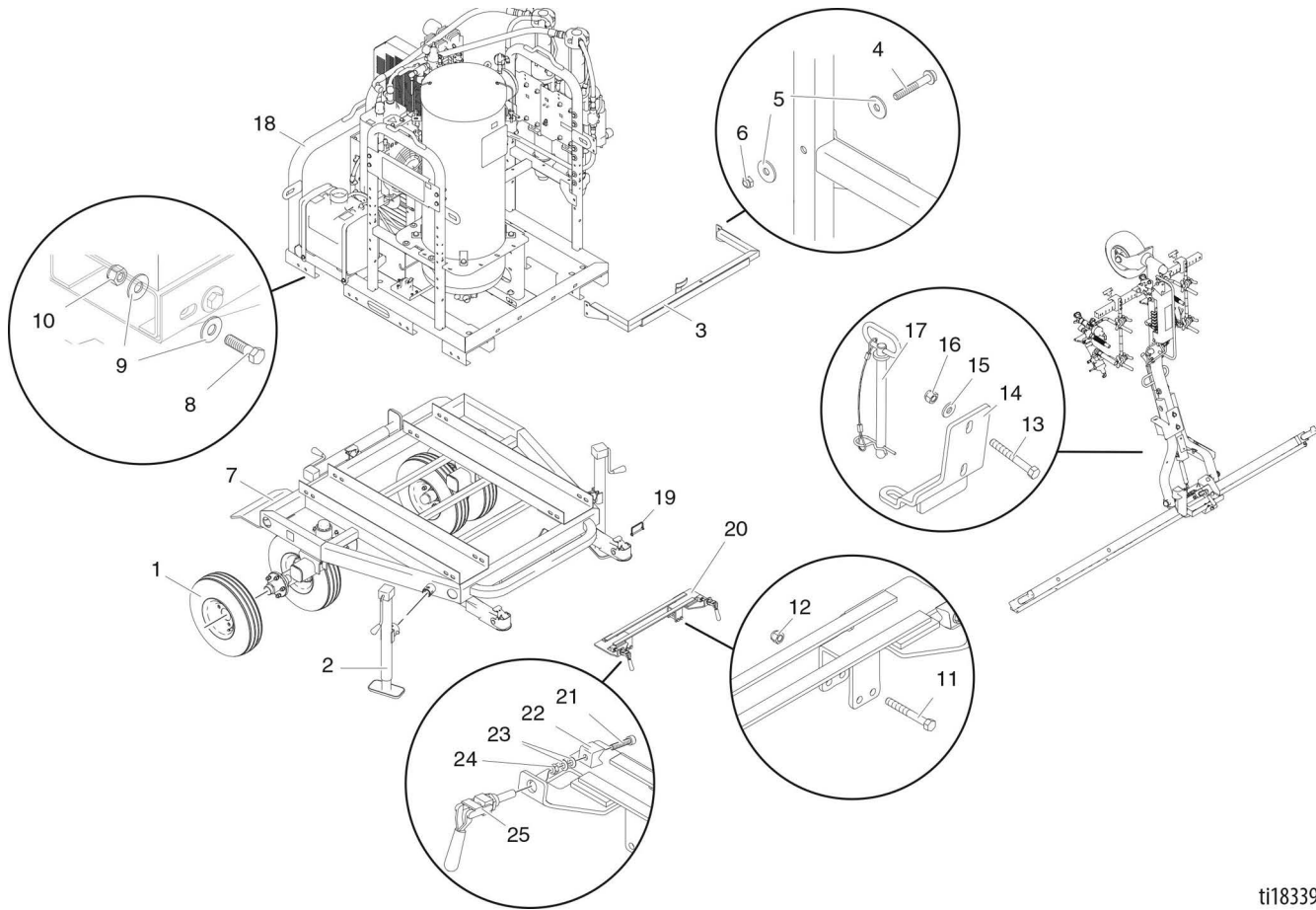

ti18339b

Parts List

Ref.	Part	Description	Qty.	Ref.	Part	Description	Qty.
1	24M140	KIT, repair, wheel, pneumatic	4	15	100023	WASHER, flat	2
2	125976	JACK	2	16	101566	NUT, lock	4
3	16M018	BRACKET, slide, weldment	1	17	115473	PIN, hitch	1
4	123982	SCREW, cap, hex head	4	18	25M701	MODULE, Roadpak, 1 pump (model 25M836)	1
5	100696	WASHER, wrought	8		24M703	MODULE, Roadpak, 2 pump (model 24M837)	1
6	126023	NUT, hex, lock	4	19	113696	PIN, safety	2
7	16M239	TRAILER, Roadpak	1	20	238301	GUIDE, bracket	1
8	125977	SCREW, cap, hex hd	8	21	113467	SCREW, cap, socket hd	2
9	125978	WASHER, plain, wide	16	22	191099	CLAMP, wedge	2
10	108527	NUT, lock, hex	8	23	113451	WASHER, wave	4
11	100454	SCREW, cap, hex hd	4	24	111040	NUT, lock, insert, nylock, 5/16	2
12	101566	NUT, lock	4	25	113304	CLAMP, cam over	2
13	100454	SCREW, cap, hex hd	4				
14	16M022	RECEIVER, pin, slide	1				

Parts

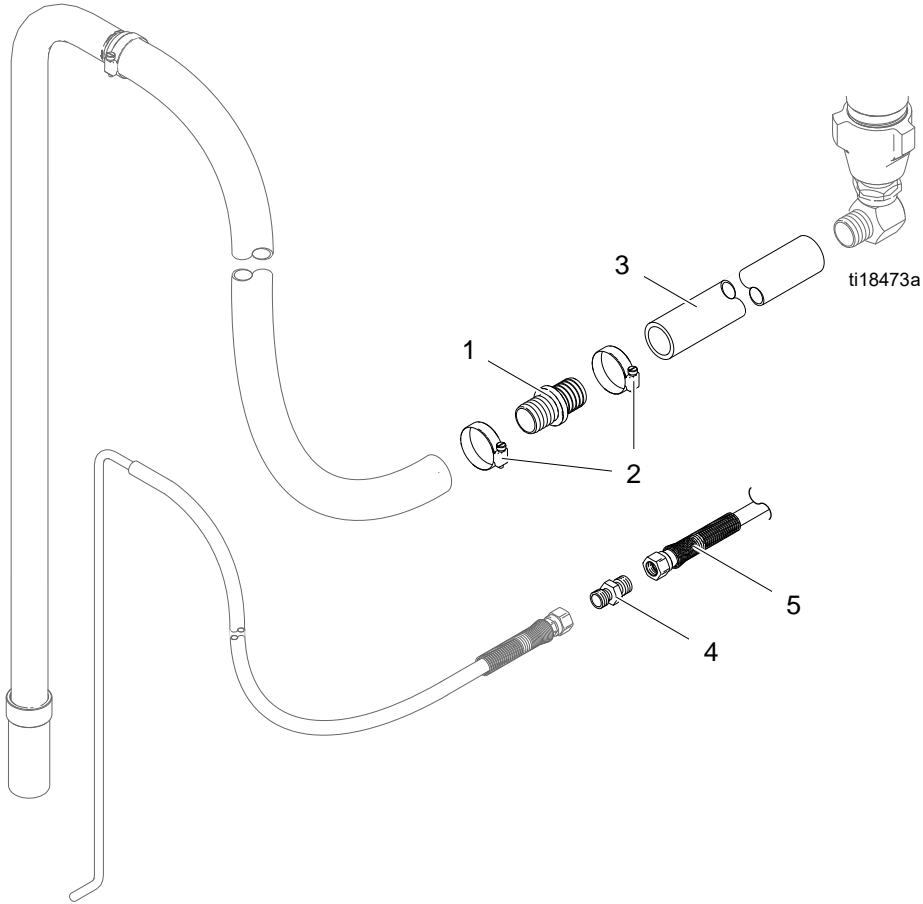

Parts List

Ref.	Part	Description	Qty.
1	16N405	FITTING, 1-1/2 x 1-1/2 hose, barbed	1
2	101368	CLAMP, hose	2
3	24M136	HOSE, suction, 8.5 ft	1
4	162453	CONNECTOR, hose connector, 1/4 NPSM x 1/4 NPT	1
5	24M253	HOSE, coupled, 1/4 in. x 10 ft	1

Technical Data

	RoadPak
	US (Metric)
Maximum Working Pressure	
Paint	2900 psi (200 bar)
Hydraulics	1950 psi (134 bar)
Glass bead system	75 psi (5 bar)
Maximum paint flow	5 gpm (18.9 lpm)@ 2000 psi (138 bar)
Operating pressure of air-actuated trigger	
Minimum	80 psi (5.5 bar)
Maximum	200 psi (14 bar)
Sound levels per ISO-3744	
Sound power level	111.7 dB(A)
Sound pressure level	91.7 dB(A)
Weight	
25M701 (1-Pump RoadPak)	850 lb (386 kg)
25M703 (2-Pump RoadPak)	950 lb (431 kg)
25M708 (1-Pump/2-Gun Arm)	128 lb (58 kg)
25M709 (2-Pump/2-Gun Arm)	132 lb (60 kg)
24G627 Slide-in Mounting Frame	170 lb (77 kg)
24G626 Hitch Mounting Frame	120 lb (54 kg)
Engine	Kohler® 19 HP (14.2 kW)
Hydraulic oil reservoir capacity	4 gallons (15 liters)
Compressor Oil	9502 SAE 30W non-detergent oil
Hydraulic Oil	ISO 46 synthetic with a VI equal or greater than 154
Glass bead capacity	450 lb (204 kg)/36 gal. (136 L)
<i>Kohler® is a registered trademark of the Kohler Co.</i>	
<i>Dyna Beads® is a registered trademark of Innovative Balancing.</i>	
* Add 450 lb (204 kg) for a full glass bead tank. Do not install the second bead tank option.	
Not to be used with 1350 lb. (120 gal) Bead Tank.	

Graco Standard Warranty

Graco warrants all equipment referenced in this document which is manufactured by Graco and bearing its name to be free from defects in material and workmanship on the date of sale to the original purchaser for use. With the exception of any special, extended, or limited warranty published by Graco, Graco will, for a period of twelve months from the date of sale, repair or replace any part of the equipment determined by Graco to be defective. This warranty applies only when the equipment is installed, operated and maintained in accordance with Graco's written recommendations.

This warranty does not cover, and Graco shall not be liable for general wear and tear, or any malfunction, damage or wear caused by faulty installation, misapplication, abrasion, corrosion, inadequate or improper maintenance, negligence, accident, tampering, or substitution of non-Graco component parts. Nor shall Graco be liable for malfunction, damage or wear caused by the incompatibility of Graco equipment with structures, accessories, equipment or materials not supplied by Graco, or the improper design, manufacture, installation, operation or maintenance of structures, accessories, equipment or materials not supplied by Graco.

This warranty is conditioned upon the prepaid return of the equipment claimed to be defective to an authorized Graco distributor for verification of the claimed defect. If the claimed defect is verified, Graco will repair or replace free of charge any defective parts. The equipment will be returned to the original purchaser transportation prepaid. If inspection of the equipment does not disclose any defect in material or workmanship, repairs will be made at a reasonable charge, which charges may include the costs of parts, labor, and transportation.

THIS WARRANTY IS EXCLUSIVE, AND IS IN LIEU OF ANY OTHER WARRANTIES, EXPRESS OR IMPLIED, INCLUDING BUT NOT LIMITED TO WARRANTY OF MERCHANTABILITY OR WARRANTY OF FITNESS FOR A PARTICULAR PURPOSE.

Graco's sole obligation and buyer's sole remedy for any breach of warranty shall be as set forth above. The buyer agrees that no other remedy (including, but not limited to, incidental or consequential damages for lost profits, lost sales, injury to person or property, or any other incidental or consequential loss) shall be available. Any action for breach of warranty must be brought within two (2) years of the date of sale.

GRACO MAKES NO WARRANTY, AND DISCLAIMS ALL IMPLIED WARRANTIES OF MERCHANTABILITY AND FITNESS FOR A PARTICULAR PURPOSE, IN CONNECTION WITH ACCESSORIES, EQUIPMENT, MATERIALS OR COMPONENTS SOLD BUT NOT MANUFACTURED BY GRACO. These items sold, but not manufactured by Graco (such as electric motors, switches, hose, etc.), are subject to the warranty, if any, of their manufacturer. Graco will provide purchaser with reasonable assistance in making any claim for breach of these warranties.

In no event will Graco be liable for indirect, incidental, special or consequential damages resulting from Graco supplying equipment hereunder, or the furnishing, performance, or use of any products or other goods sold hereto, whether due to a breach of contract, breach of warranty, the negligence of Graco, or otherwise.

FOR GRACO CANADA CUSTOMERS

The Parties acknowledge that they have required that the present document, as well as all documents, notices and legal proceedings entered into, given or instituted pursuant hereto or relating directly or indirectly hereto, be drawn up in English. Les parties reconnaissent avoir convenu que la rédaction du présente document sera en Anglais, ainsi que tous documents, avis et procédures judiciaires exécutés, donnés ou intentés, à la suite de ou en rapport, directement ou indirectement, avec les procédures concernées.

Graco Information

For the latest information about Graco products, visit www.graco.com.

For patent information, see www.graco.com/patents.

TO PLACE AN ORDER, contact your Graco distributor or call 1-800-690-2894 to identify the nearest distributor.

*All written and visual data contained in this document reflects the latest product information available at the time of publication.
Graco reserves the right to make changes at any time without notice.*

For patent information, see www.graco.com/patents.

Original instructions. This manual contains English. MM 3A2091

Graco Headquarters: Minneapolis

International Offices: Belgium, China, Japan, Korea

GRACO INC. AND SUBSIDIARIES • P.O. BOX 1441 • MINNEAPOLIS MN 55440-1441 • USA
Copyright 2011, Graco Inc. All Graco manufacturing locations are registered to ISO 9001.

www.graco.com

Revised E, September 2024