

# Stainless Steel Tank Stands

3A0395ZAC

EN

***For supplying material to HFR™ plural-component proportioners. For professional use only.***

**Not approved for use in European explosive atmosphere locations. Not approved for use in European explosive atmosphere locations.**

*100 psi (0.7 MPa, 7.0 bar) Maximum Working Pressure*

*100 psi (0.7 MPa, 7.0 bar) Maximum Air Pressure*



## **Important Safety Instructions**

Read all warnings and instructions in this manual. Save these instructions.

See page 3 for model information.

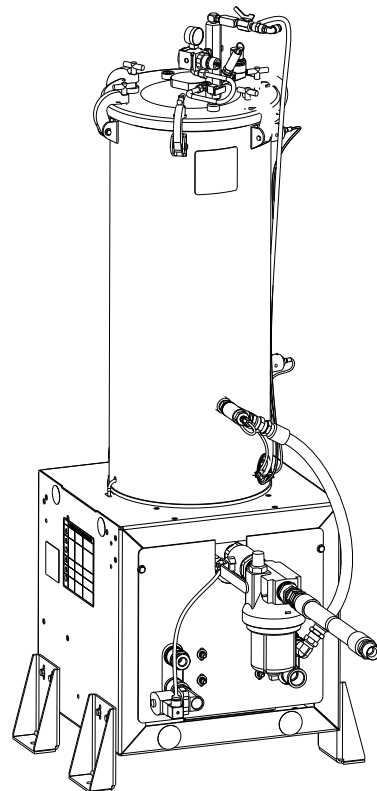

# Contents

<b>Models</b> .....	<b>3</b>
<b>Related Manuals</b> .....	<b>3</b>
<b>Warnings</b> .....	<b>4</b>
<b>Important Two-Component Material Information</b>	<b>6</b>
Isocyanate Conditions .....	6
Material Self-ignition .....	6
Keep Components A and B Separate .....	6
Moisture Sensitivity of Isocyanates .....	6
Foam Resins with 245 fa Blowing Agents .....	6
Changing Materials .....	7
<b>Component Identification</b> .....	<b>8</b>
Tank Feed System .....	8
Electrical Panel Components .....	9
<b>Installation</b> .....	<b>12</b>
Grounding .....	12
Install Tank Stand .....	12
Install Barrel Style Level Sensors .....	12
Install Ultrasonic Level Sensor .....	14
Install Chiller (customer supplied) .....	14
Auto-Refill Installation: customer supplied feed system .....	15
Auto-Refill Installation: Graco supplied feed system .....	15
<b>Setup</b> .....	<b>16</b>
Calibrate Barrel Style Level Sensors .....	16
Vacuum De-gas .....	16
<b>Operation</b> .....	<b>17</b>
Startup .....	17
Pressure Relief Procedure .....	17
<b>Maintenance</b> .....	<b>18</b>
Daily Maintenance .....	18
Weekly Maintenance .....	18
Install Upgrade Tokens .....	18
<b>Troubleshooting</b> .....	<b>19</b>
<b>Repair</b> .....	<b>27</b>
Replace Agitator Fuse .....	27
Tank Lid Gasket .....	27
Level Sensor and Well .....	29
<b>Electrical Schematics</b> .....	<b>30</b>
Electrical Panel, Tank Stand with Agitator, Heater/Chiller .....	30
Electrical Panel, Tank Stand with Agitator .....	34

<b>Parts</b> .....	<b>37</b>
38L and 75L Tank Modules .....	37
38L and 75L Tank Module Parts .....	40
2 Gallon Tank Module - 24J243 .....	44
Heated Tank Assemblies .....	47
Tank Lid Assemblies .....	48
Electrical Panel 230V for Heat .....	54
Electrical Panel 230V for No Heat .....	55
Electrical Panel, 230V for 2 Gallon Tanks Only ..	57
Heat Exchanger Assembly .....	59
Air Dryer Filter .....	60
Ball Valve Assemblies .....	61
Recirculation Probe Assembly .....	62
Transfer Pump Valve, 24C157 .....	63
<b>Accessories and Kits</b> .....	<b>64</b>
<b>Dimensions</b> .....	<b>68</b>
<b>Technical Data</b> .....	<b>69</b>
<b>Graco Standard Warranty</b> .....	<b>70</b>
<b>Graco Information</b> .....	<b>70</b>

# Models

The following table lists the tank stand module part numbers and the components included with each.

Part	Includes:							
	Agitator	Slinger Plate	Heat	Insulation	Chiller	Desiccant Dryer	Level Sensors	Filter
38 Liter (10 Gallon) Tanks								
24D562					✓	✓	✓	✓
24D564	✓				✓	✓	✓	✓
24D568						✓		
24D569						✓	✓	
24D570	✓					✓	✓	
24D571	✓	✓				✓	✓	
24D572	✓	✓	✓	✓		✓	✓	
24D573	✓		✓	✓		✓	✓	
75 Liter (19.8 Gallon) Tanks								
24D565					✓	✓	✓	✓
24C317	✓				✓	✓	✓	✓
24D574							✓	
24D575							✓	
24D576	✓						✓	
24D577	✓	✓					✓	
24D578	✓	✓	✓	✓			✓	
24D579	✓		✓	✓			✓	
24P091 (circ spray)	✓		✓	✓		✓	✓	
24J209 (NVH)				✓		✓	✓	
7.5 Liter (2 Gallon) Tanks								
24J243 (NVH)						✓	✓	





## Related Manuals

Component manuals listed below are in English.  
Manuals are available at [www.graco.com](http://www.graco.com).

Manual No.	Description
3A1936	Pneumatic and Electric Agitator Kits

# Warnings

The following warnings are for the setup, use, grounding, maintenance, and repair of this equipment. The exclamation point symbol alerts you to a general warning and the hazard symbols refer to procedure-specific risks. When these symbols appear in the body of this manual, refer back to these Warnings. Product-specific hazard symbols and warnings not covered in this section may appear throughout the body of this manual where applicable.

 <b>WARNING</b>	
	<p><b>ELECTRIC SHOCK HAZARD</b></p> <p>This equipment must be grounded. Improper grounding, setup, or usage of the system can cause electric shock.</p> <ul style="list-style-type: none"> <li>• Turn off and disconnect power at main switch before disconnecting any cables and before servicing equipment.</li> <li>• Connect only to grounded power source.</li> <li>• All electrical wiring must be done by a qualified electrician and comply with all local codes and regulations.</li> </ul>
	<p><b>PRESSURIZED EQUIPMENT HAZARD</b></p> <p>Fluid from the gun/dispense valve, leaks, or ruptured components can splash in the eyes or on skin and cause serious injury.</p> <ul style="list-style-type: none"> <li>• Follow the <b>Pressure Relief Procedure</b> when you stop spraying and before cleaning, checking, or servicing equipment.</li> <li>• Tighten all fluid connections before operating the equipment.</li> <li>• Check hoses, tubes, and couplings daily. Replace worn or damaged parts immediately.</li> </ul>
	<p><b>TOXIC FLUID OR FUMES HAZARD</b></p> <p>Toxic fluids or fumes can cause serious injury or death if splashed in the eyes or on skin, inhaled, or swallowed.</p> <ul style="list-style-type: none"> <li>• Read MSDSs to know the specific hazards of the fluids you are using.</li> <li>• Store hazardous fluid in approved containers, and dispose of it according to applicable guidelines.</li> <li>• Always wear chemically impermeable gloves when spraying, dispensing, or cleaning equipment.</li> </ul>
	<p><b>PERSONAL PROTECTIVE EQUIPMENT</b></p> <p>You must wear appropriate protective equipment when operating, servicing, or when in the operating area of the equipment to help protect you from serious injury, including eye injury, hearing loss, inhalation of toxic fumes, and burns. This equipment includes but is not limited to:</p> <ul style="list-style-type: none"> <li>• Protective eyewear, and hearing protection.</li> <li>• Respirators, protective clothing, and gloves as recommended by the fluid and solvent manufacturer</li> </ul>

# ! WARNING



## FIRE AND EXPLOSION HAZARD

Flammable fumes, such as solvent and paint fumes, in **work area** can ignite or explode. To help prevent fire and explosion:

- Use equipment only in well ventilated area.
- Eliminate all ignition sources; such as pilot lights, cigarettes, portable electric lamps, and plastic drop cloths (potential static arc).
- Keep work area free of debris, including solvent, rags and gasoline.
- Do not plug or unplug power cords, or turn power or light switches on or off when flammable fumes are present.
- Ground all equipment in the work area. See **Grounding** instructions.
- Use only grounded hoses.
- Hold gun firmly to side of grounded pail when triggering into pail.
- If there is static sparking or you feel a shock, **stop operation immediately**. Do not use equipment until you identify and correct the problem.
- Keep a working fire extinguisher in the work area.



## EQUIPMENT MISUSE HAZARD

Misuse can cause death or serious injury.

- Do not operate the unit when fatigued or under the influence of drugs or alcohol.
- Do not exceed the maximum working pressure or temperature rating of the lowest rated system component. See **Technical Data** in all equipment manuals.
- Use fluids and solvents that are compatible with equipment wetted parts. See **Technical Data** in all equipment manuals. Read fluid and solvent manufacturer's warnings. For complete information about your material, request MSDS from distributor or retailer.
- Do not leave the work area while equipment is energized or under pressure. Turn off all equipment and follow the **Pressure Relief Procedure** when equipment is not in use.
- Check equipment daily. Repair or replace worn or damaged parts immediately with genuine manufacturer's replacement parts only.
- Do not alter or modify equipment.
- Use equipment only for its intended purpose. Call your distributor for information.
- Route hoses and cables away from traffic areas, sharp edges, moving parts, and hot surfaces.
- Do not kink or over bend hoses or use hoses to pull equipment.
- Keep children and animals away from work area.
- Comply with all applicable safety regulations.







## BURN HAZARD

Equipment surfaces and fluid that's heated can become very hot during operation. To avoid severe burns:

- Do not touch hot fluid or equipment.

# Important Two-Component Material Information

## Isocyanate Conditions

						
--	---	---	---	---	--	--



Spraying or dispensing materials containing isocyanates creates potentially harmful mists, vapors, and atomized particulates.

Read material manufacturer’s warnings and material MSDS to know specific hazards and precautions related to isocyanates.

Prevent inhalation of isocyanate mists, vapors, and atomized particulates by providing sufficient ventilation in the work area. If sufficient ventilation is not available, a supplied-air respirator is required for everyone in the work area.



To prevent contact with isocyanates, appropriate personal protective equipment, including chemically impermeable gloves, boots, aprons, and goggles, is also required for everyone in the work area.

## Material Self-ignition

						
--	---	--	--	--	--	--

Some materials may become self-igniting if applied too thickly. Read material manufacturer’s warnings and material MSDS.

## Keep Components A and B Separate

						
--	---	---	--	--	--	--

Cross-contamination can result in cured material in fluid lines which could cause serious injury or damage equipment. To prevent cross-contamination of the equipment’s wetted parts, **never** interchange component A (isocyanate) and component B (resin) parts.

## Moisture Sensitivity of Isocyanates

Isocyanates (ISO) are catalysts used in two component foam and polyurea coatings. ISO will react with moisture (such as humidity) to form small, hard, abrasive crystals, which become suspended in the fluid. Eventually a film will form on the surface and the ISO will begin to gel, increasing in viscosity. If used, this partially cured ISO will reduce performance and the life of all wetted parts.

**NOTE:** The amount of film formation and rate of crystallization varies depending on the blend of ISO, the humidity, and the temperature.

To prevent exposing ISO to moisture:

- Always use a sealed container with a desiccant dryer in the vent, or a nitrogen atmosphere. **Never** store ISO in an open container.
- Keep the ISO lube pump reservoir (if installed) filled with Graco Throat Seal Liquid™ (TSL™), Part 206995. The lubricant creates a barrier between the ISO and the atmosphere.
- Use moisture-proof hoses specifically designed for ISO, such as those supplied with your system.
- Never use reclaimed solvents, which may contain moisture. Always keep solvent containers closed when not in use.
- Never use solvent on one side if it has been contaminated from the other side.
- Always lubricate threaded parts with ISO pump oil or grease when reassembling.

## Foam Resins with 245 fa Blowing Agents

Some foam blowing agents will froth at temperatures above 90°F (33°C) when not under pressure, especially if agitated. To reduce frothing, minimize preheating in a circulation system.

## Changing Materials

- When changing materials, flush the equipment multiple times to ensure it is thoroughly clean.
- Always clean the fluid inlet strainers after flushing.
- Check with your material manufacturer for chemical compatibility.
- Most materials use ISO on the A side, but some use ISO on the B side.
- Epoxies often have amines on the B (hardener) side. Polyureas often have amines on the B (resin) side.

# Component Identification

## Tank Feed System

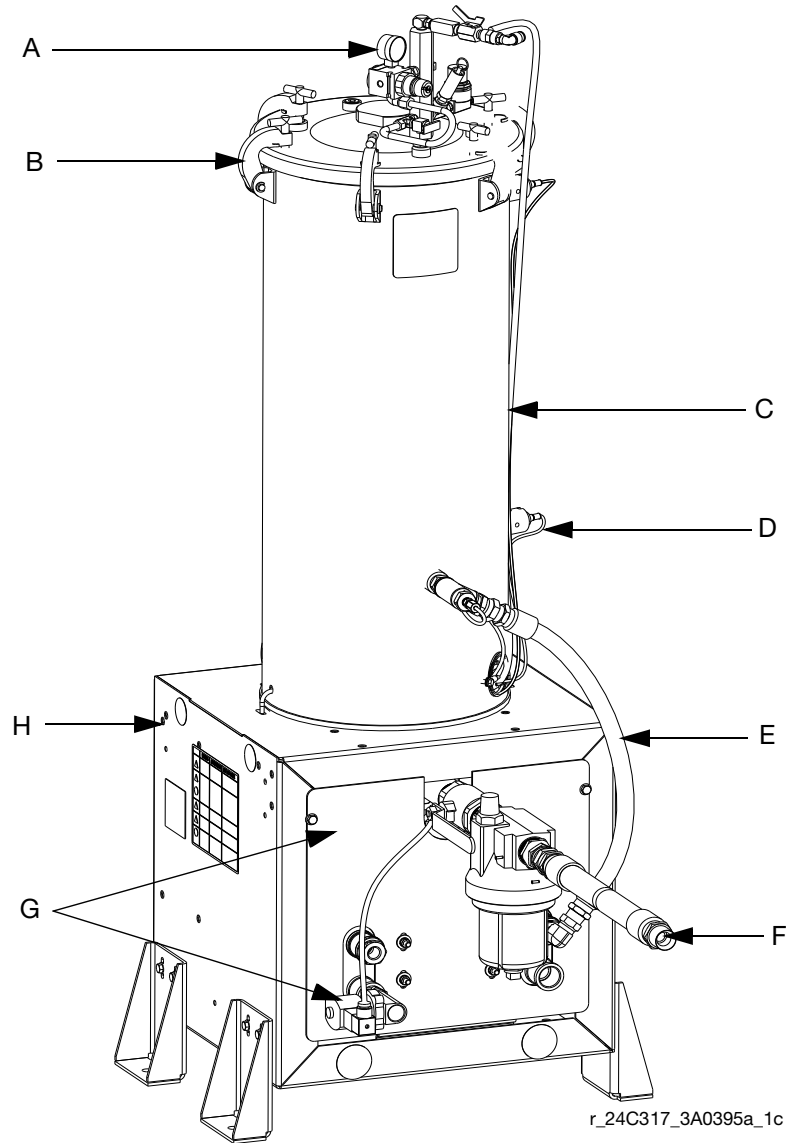

**FIG. 1: Component Identification - Tank Feed System**

**Key:**

- |   |                              |   |                           |
|---|------------------------------|---|---------------------------|
| A | Air Pressure Gauge and Valve | H | Enclosure                 |
| B | Lid or Lid with Agitator     | J | Level Sensors (not shown) |
| C | Tank                         |   |                           |
| D | Material Valve               |   |                           |
| E | Recirculation Probe Assembly |   |                           |
| F | Ball Valve Assembly          |   |                           |
| G | Heat Exchanger Assembly      |   |                           |



## Electrical Panel Components

The electrical panel is located on the inside of the tank stand enclosure, and includes the circuit breakers, a fluid control module, and a low power temperature control module.

### Circuit Breakers

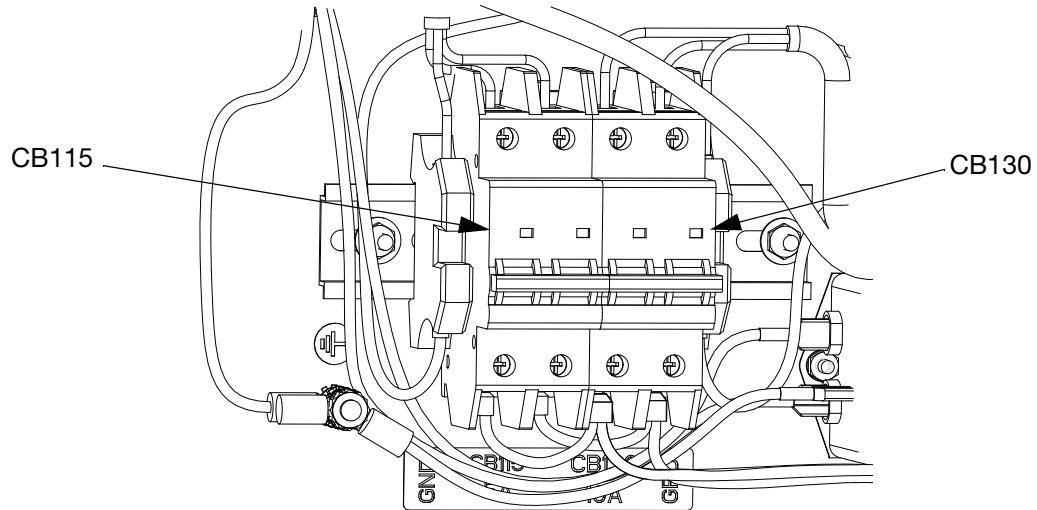

**FIG. 2: Component Identification - Circuit Breakers**

Ref.	Size	Component
CB115	5A	Agitator
CB130	10A	Low power temperature control module / heat blanket / chiller

### Fluid Control Module (FCM)

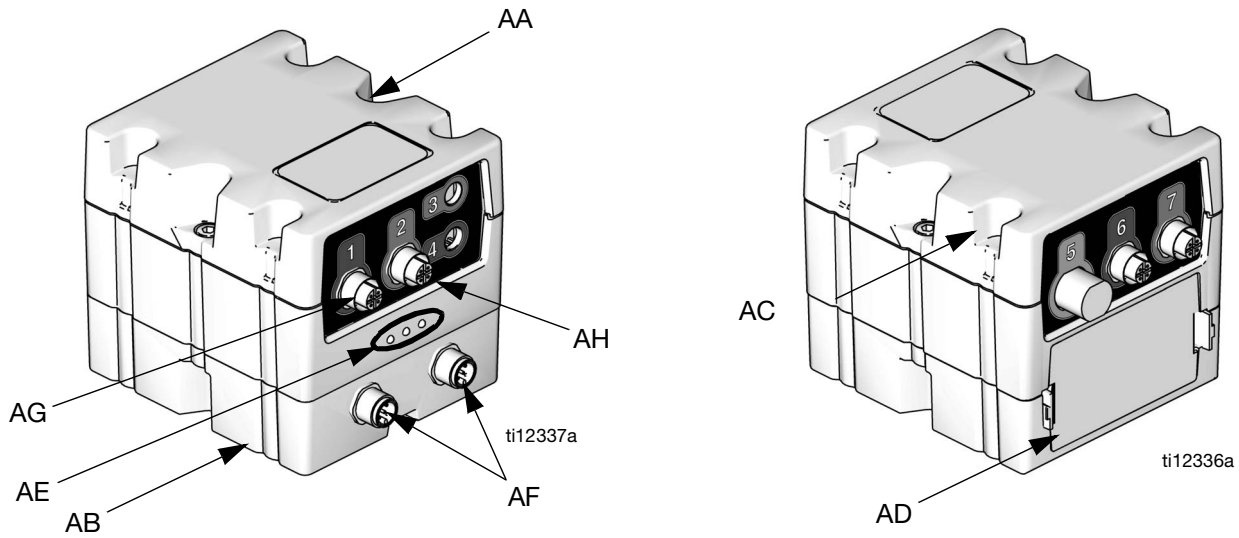
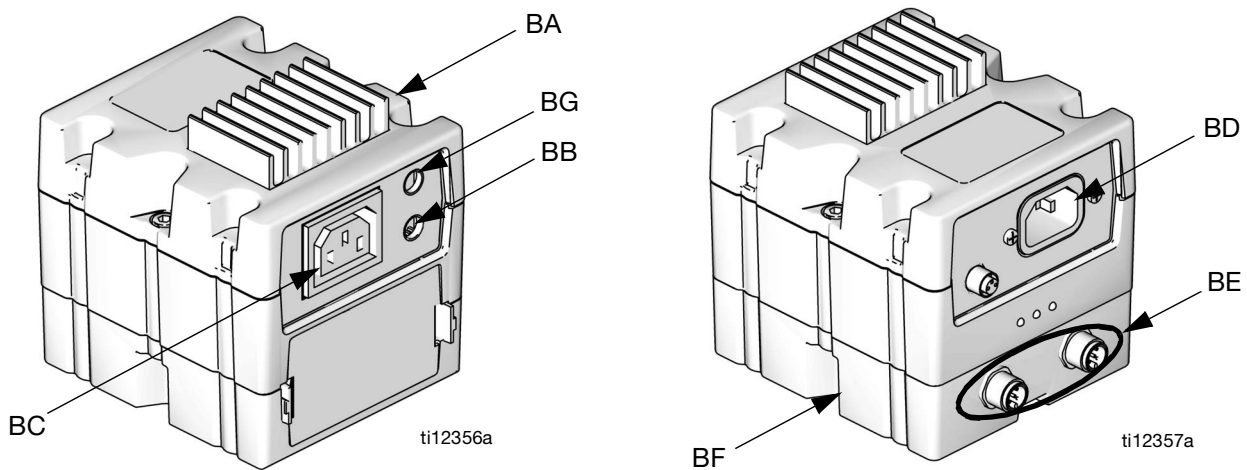

**FIG. 3: Component Identification - FCM**

**Key:**

- AA Fluid Control Module (FCM)
- AB Base
- AC Module Connection Screws
- AD Access Cover
- AE Module Status LEDs
- AF CAN Connectors
- AG Level Sensor Input
- AH Fill Solenoid Signal

### Low Power Temperature Control Module



**FIG. 4: Component Identification - Low Power Module**

**Key:**

- BA Low Power Module
- BB RTD Temperature Sensor Connection (for chiller or for RTD in bottom of tank when using a heated blanket)
- BC Output Power Connection
- BD Input Power Connection
- BE CAN Connectors
- BF Base
- BG RTD Temperature Sensor Connection (for RTD under heated blanket)

### Heat Zone and Fluid Control Selection

The tank feed system supports independent temperature control by utilizing a low power temperature control module. The system also supports fluid control by utilizing an FCM. Both the low power temperature control module and the FCM are located on the electrical panel within the enclosure.

**NOTE: Tank stands are configured for the A (Red) side. Adjust rotary switch setting if tank is being used on B (Blue) side.**

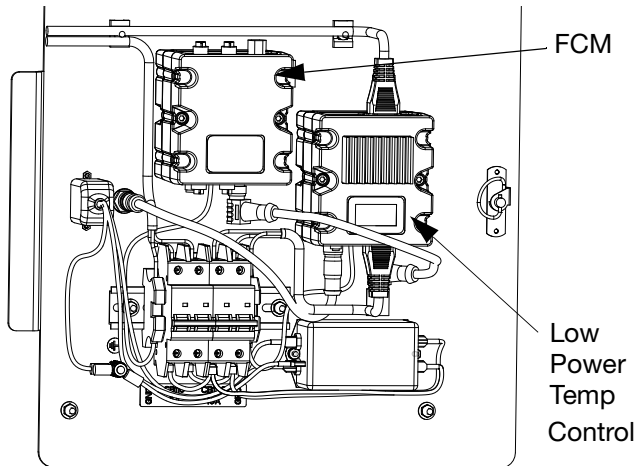

r\_24C169\_3A0395\_1a

**FIG. 5: Electrical Panel**

### Adjust Rotary Switch

The rotary switch setting indicates which zone the temperature control module will control in the system. The low power module and FCM use a 16-position rotary switch to make selections.

Set the rotary switch to the specific selection according to the settings listed in the following tables.

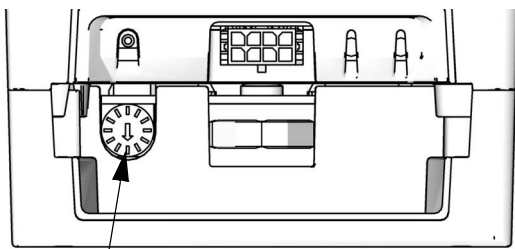

Rotary Switch

ti12361a

**FIG. 6: Adjust Rotary Switch**

### Low Power Temperature Control Module Rotary Switch Settings

Setting	Zone
0-4	Not Used
5	B (Blue) Tank Heater
6	A (Red) Tank Heater
7	B (Blue) Chiller
8	A (Red) Chiller
9-F	Not Used

### FCM Rotary Switch Settings

Setting	Zone
0-2	Not Used
3	B (Blue) Tank Refill
4	A (Red) Tank Refill
5-F	Not Used

# Installation

## Grounding



Products that include heated tanks must be grounded. Grounding reduces the risk of static and electric shock by providing an escape wire for the electrical current due to static build up or in the event of a short circuit.

Improper installation of the grounding plug increases the risk of electric shock. Do not modify the plug provided; if it does not fit the outlet, have the proper outlet installed by a qualified electrician. Only connect the product to an outlet having the same configuration as the plug. Do not use an adapter with this product.

## Install Tank Stand

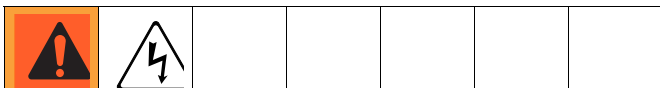

1. Install the tank stand no more than 6 ft. (1.8 m) from the rear of the material pumps on the HFR system.
2. Anchor the tank stand to the floor. (Suggested anchors: McMaster-Carr anchor, 92403A400.) See **Dimensions**, page 68.
3. Plug the tank stand power cable into the bottom of the HFR power distribution box.
4. Plug the tank stand CAN cable into the CAN splitter inside the distribution box.

**NOTE: Tank stands are configured for the A (Red) side. Adjust rotary switch setting if tank is being used on B (Blue) side.**

## Install Barrel Style Level Sensors



1. Turn main power off.
2. Relieve tank air pressure. See **Pressure Relief Procedure**, page 17.
3. Drain tanks below the lowest level sensor well.

### If installing high temperature level sensors:

4. Apply PTFE paste and PTFE tape to the male threads of the level sensor.
5. Being careful to not cross-threads, thread the level sensor (CB) into the corresponding tank port.

To avoid improper operation, ensure the mark (dot or arrow) found on the hex of the level sensor is pointing towards the top or bottom of the machine after tightening.

6. Plug the sensor cable adapter into the level sensor.
7. Plug the sensor connector (CD) into the level sensor adapter.
8. Plug the sensor connector into the connector on the FCM.

### If installing low temperature level sensors:

**NOTE: For proper level sensor function, the tip of the level sensor well must protrude at least 1/8 in. into the tank (C).**

- Route each level sensor (H) wire (J1, J2, J3) through the corresponding well nut (CC). See FIG. 8 for wire location on tank.

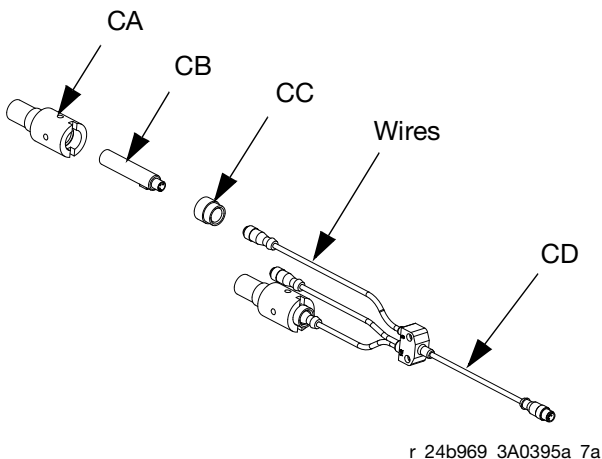

r\_24b969\_3A0395a\_7a

**FIG. 7: Level Sensor Assembly**

- Measure the length of the level sensor well housing, and then measure the depth of the hole in the tank where the well is inserted. Note these measurements as they will be need later.
- Being careful to not cross-threads, thread assembled level sensor (CB) into well housing until it bottoms out against the bottom of the well. The bottom of the level sensor will be slightly visible through the bottom of the well.

**NOTE: In the following step, do not allow PTFE paste or tape to cover the tip of the level sensor well. If paste comes in contact with the tip of the level sensor well, thoroughly wipe it clean.**

- Apply PTFE paste and PTFE tape to the male threads of the level sensor well housing.

- Being careful to not cross-threads, thread the level sensor well (CA) into the corresponding tank port and lightly tighten with a crescent wrench.

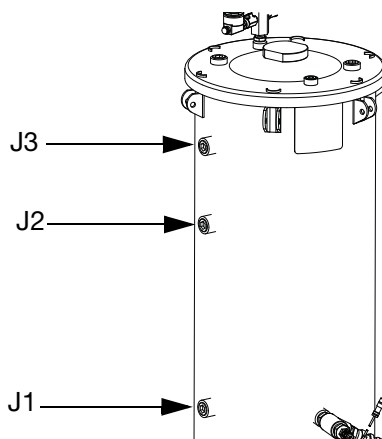

**FIG. 8: Tank Ports**

- Measure the amount of the level sensor well housing that is visible beyond the day tank hole, then perform the following equation:

$$P = L1 - (L2 + L3)$$

- P = Protrusion length (inside of day tank)
- L1 = Length of level sensor well
- L2 = Visible length of level sensor well
- L3 = Length of well threads in day tank

- The protrusion length must be at least 1/8 in. (3.2 mm). If not, remove the level sensor well and restart at step 10.
- Rotate level sensor to optimal position for wire routing.
- Plug the sensor connector (CD) into the level sensors.



Ensure the level sensors are installed in the sensor well housings before pressurizing the tank. Failing to do so could cause the well housings to rupture, which may result in serious injury and material leakage.

- Plug the sensor connector into the connector on the FCM.
- Calibrate the sensor. See **Calibrate Barrel Style Level Sensors**, page 16.

## Install Ultrasonic Level Sensor



**NOTE:** The ultrasonic level sensor is only used on two gallon tanks.

1. Turn main power off.
2. Relieve tank air pressure. See **Pressure Relief Procedure**, page 17.
3. Drain tank.
4. Remove the tank lid (DA).
5. Insert the o-ring (DB) and sensor well housing (DC) into the tank port.

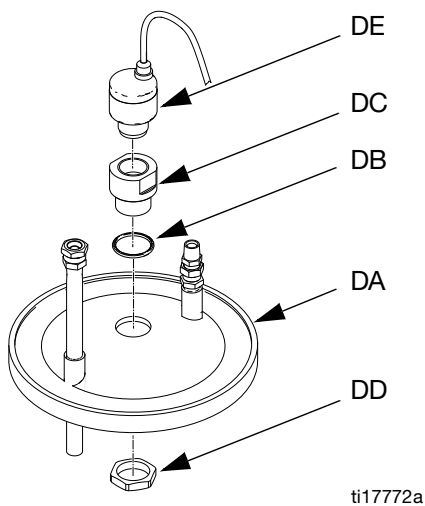

**FIG. 9: Ultrasonic Level Sensor**

6. Tighten the jam nut (DD) to ensure there will not be any air leakage.
7. Hand tighten the level sensor (DE).
8. Plug the sensor connector into the connector on the FCM.

## Install Chiller (customer supplied)

The following instructions apply to tank modules (24C317, 24D562, 24D564, 24D565) that include the heat exchanger assembly (G).

Graco does not supply the chiller assembly.

1. Connect incoming water to inlet heat exchanger port.
2. Connect outgoing water to outlet heat exchanger port.

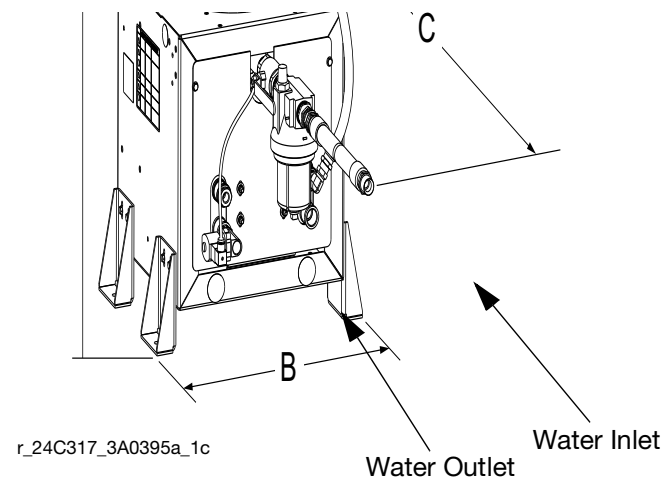

**FIG. 10: Level Sensor Assembly**

3. Configure the advanced display module (ADM) for the chiller option. See the HFR Setup-Operation manual for instructions.

## Auto-Refill Installation: customer supplied feed system

The auto-refill assembly is not assembled when shipped.

1. Empty tank (C).
2. Remove plug from lower, rear of tank.
3. Install auto-refill assembly in 3/4 npt port.
4. Connect hose (not supplied) to 1/2 npt port on material valve.

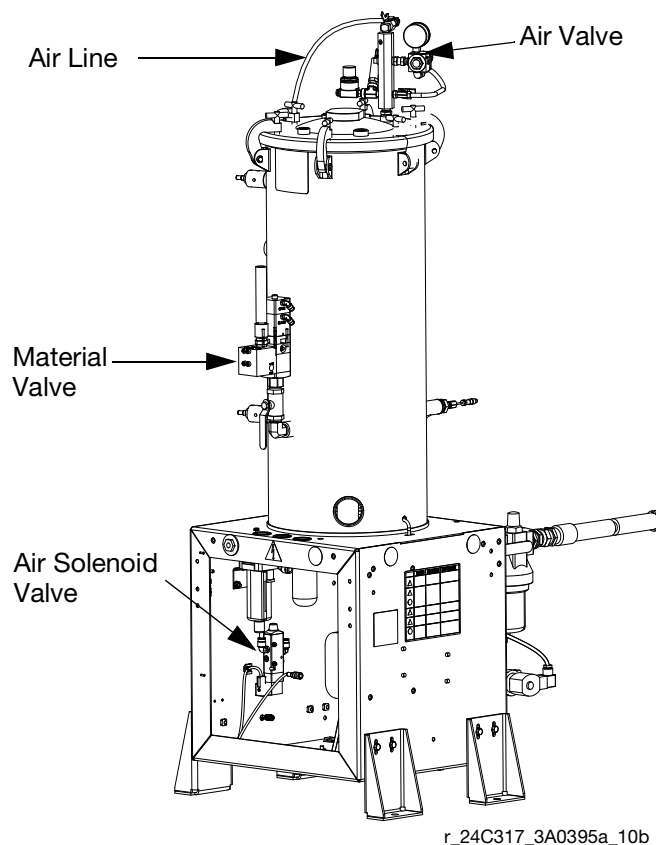

r\_24C317\_3A0395a\_10b

**FIG. 11: Tank Assembly**

5. Connect air lines from air valve (A) to material valve (D).
6. Connect main air line to air valve.

## Auto-Refill Installation: Graco supplied feed system

The auto-refill assembly is not assembled when shipped.

1. Empty tank (C).
2. Remove plug from lower, rear of tank.
3. Connect feed pump outlet hose to tank.
4. Connect air lines from air valve to feed pump.
5. Connect main air line to air valve.

# Setup

## Calibrate Barrel Style Level Sensors

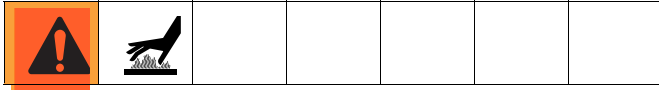

**NOTE: Calibration is not required for ultrasonic style level sensors or high temperature level sensors.**

1. Locate the calibration button on the sensor (11) closest to the electrical connector through one of the four holes of the sensor well housing (CA).
2. If the calibration button cannot be seen through one of the four holes in the sensor well, rotate the sensor.
  - a. Loosen the sensor well nut (CC).
  - b. Rotate sensor until the calibration button can be seen through one of the four holes in the sensor well housing.
  - c. Tighten sensor well nut.
  - d. Press and hold the button down with the ball end of an allen wrench for two seconds. The light will flash slowly and then go out.
3. Test for proper sensor function.
  - a. Loosen the sensor well nut.
  - b. Back the sensor out of the well. The sensor should sense the tank wall.

## Vacuum De-gas

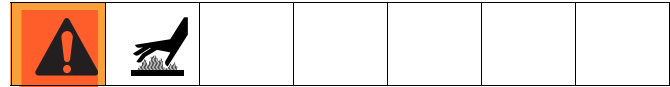

**NOTE: Only perform the following procedures for tank volumes other than two gallons.**

1. Shut down the HFR system. Refer to the HFR Setup-Operation manual for instructions.
2. Close the shut-off ball valves at the base of the tanks.
3. If the tank lid has a fill port, turn off any systems that might refill the tank during the vacuum de-gas procedure.
4. Close the fill port ball valve.
5. If the tank lid requires a desiccant dryer, install it into the top ball valve of the vacuum tree manifold.
6. Close the top ball valve of the vacuum tree manifold.
7. Attach vacuum pump to the bottom ball valve of the vacuum tree manifold. Open the ball valve.
8. Turn on the vacuum pump.
9. Continue to de-gas the material.
10. Close bottom ball valve of the vacuum tree manifold.
11. Turn off the vacuum pump.
12. Open the top ball valve of the vacuum tree manifold.

Operating the tank after the vacuum de-gas procedure without the top ball valve open will result in pump cavitation, off-ratio conditions, and possible collapse of the tank.

13. Open the shutoff valves at the base of the tanks.



# Operation

See HFR Setup-Operation manual for system operation instructions.

## Startup

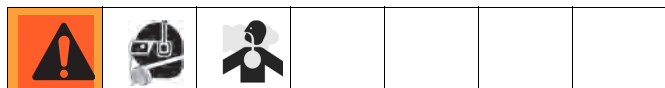

### Start System

See HFR Setup-Operation manual for system startup instructions.

### Start Agitation

Press agitator manual switch on and off to start agitation.

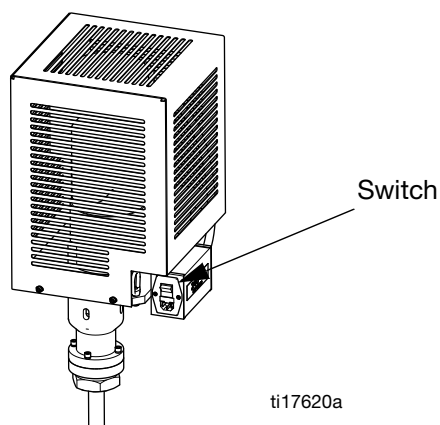

**FIG. 12: Agitator Switch**

## Pressure Relief Procedure



Relieving air pressure in the machine means that the supplied dry air will be replaced by moist air. Do not leave the machine exposed to moist air for more than 30 minutes. If the machine must be left without air pressure for more than 30 minutes, the day tanks must first be emptied and thoroughly flushed.

1. Turn off main power.
2. Close day tank incoming air supply valve.
3. Disconnect pressurized air supply hose from water separator.
4. Open the pressure relief valve on top of each day tank to bleed air pressure from system.

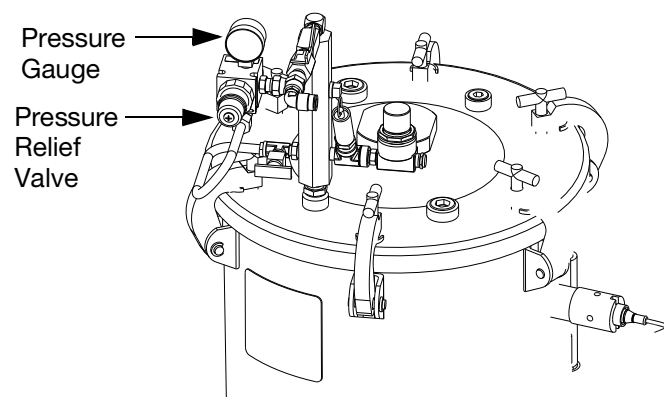

**FIG. 13: Tank Pressure Relief**

5. Ensure there is no air pressure in the tanks; look at the pressure gauges.

# Maintenance

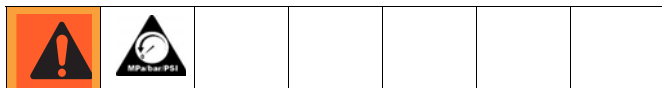

## Daily Maintenance

### Desiccant Dryer

Replace silica gel units when the desiccant color or moisture indicator has changed color from Blue (meaning dry) to Pink (meaning wet).

1. Turn off and depressurize the line containing the dryer unit.
2. Loosen the camp ring and remove the bowl from the top housing.
3. Pour out used desiccant.
4. Open new container and refill bowl
5. Shake or tap bowl to settle desiccant. Add or remove desiccant until it is 1/8 in. below the inner step of the bowl.

### Air Filter (123377)

1. Drain water separator if necessary.
2. Pressurize the air system.
3. If desired, place a container underneath water separator to catch water.
4. Push purge valve.
5. Release valve when filter is empty.

## Weekly Maintenance

### Material Filter (213062)

The red alert filter indicator provides gradual warning of a dirty element. When the indicator displays as 3/4 red, clean the element. If the element is not cleaned promptly, the filter bypass valve opens and fluid will not be filtered.

To clean the element:

1. Clean the filter element with a small paint brush.
2. Use air to blow out lodged particles.
3. Inspect for damage.
4. Replace if ruptured. See manual 307283.

## Replacement Filters

- 108111 – 30 stainless steel mesh
- 108112 – 60 stainless steel mesh
- 108113 – 100 stainless steel mesh
- 108114 – 200 stainless steel mesh
- 108115 – 150 stainless steel mesh

## Install Upgrade Tokens

**NOTE:** The Fluid Control Module and Temperature Control Module connection to the system is temporarily disabled during the installation of upgrade tokens.

To install software upgrades:

1. Use correct software token stated in the table. See Graco Control Architecture™ Module Programming manual for instructions.

**NOTE: Upgrade all modules in the system to the software version on the token, even if you are replacing only one or two modules. Different software versions may not be compatible.**

**All data in the module (System Settings, USB Logs, Recipes, Maintenance Counters) may be reset to factory default settings. Download all settings and user preferences to a USB before the upgrade, for ease of restoring them following the upgrade.**

**See manuals for locations of specific GCA components.**

**The software version history for each system can be viewed in the technical support section at [www.graco.com](http://www.graco.com).**

Token	Application
16G584	<b>Tank Stand:</b> - Fluid Control Module - Low Power Temperature Control Module

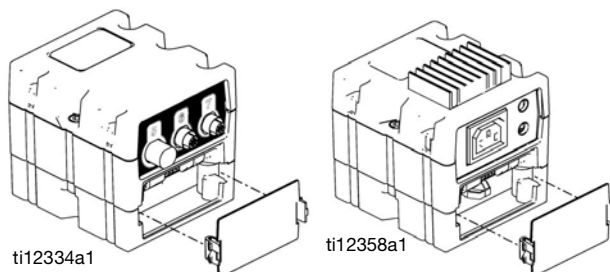

**FIG. 14: Remove Access Cover**

# Troubleshooting

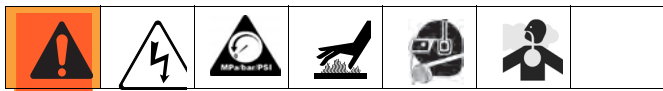

Problem	Cause	Solution
<p>No agitation.</p>	<p>Agitator motor is not turning.</p> <p>Intermittent electrical connections.</p>	<p>Ensure the system main power is ON.</p> <p>Ensure all electrical connections to the motor are secure. See electrical schematic in either the HFR Repair-Parts manual.</p> <p>Check fuse at agitator switch.</p> <p>Check if motor circuit breaker in base cube has tripped. See electrical schematic in either the HFR Repair-Parts manual.</p> <p>Check if tank stand circuit breaker in power distribution module has tripped. See electrical schematic in either the HFR Repair-Parts manual.</p> <p>Replace motor.</p>
<p>No vacuum suction in tank.</p>	<p>Vacuum pump is not functioning.</p> <p>Vacuum lines damaged or leaking.</p>	<p>Check power cord from wall.</p> <p>Ensure vacuum pump power is ON.</p> <p>Ensure connections from vacuum line to tank lid are secure.</p> <p>Ensure there are no kinks or links in vacuum line to tank lid.</p> <p>Replace vacuum pump.</p>

Problem	Cause	Solution
<p>Material is not heating.</p>	<p>Blanket heater not working.</p> <p>Intermittent electrical connections.</p> <p>Material temperature variations.</p> <p>FCM errors.</p>	<p>Ensure the system main power is ON.</p> <p>Ensure all electrical connections to the blanket heater are secure. See electrical schematic in either the HFR Repair-Parts manual.</p> <p>Ensure the tank RTD connections are secure. See electrical schematic in either the HFR Repair-Parts manual.</p> <p>Check if FCM circuit breaker has tripped. See electrical schematic in either the HFR Repair-Parts manual.</p> <p>Check if tank stand circuit breaker in GMS™ power distribution box has tripped. See electrical schematic in either the HFR Repair-Parts manual.</p> <p>Check FCM. A red LED indicates a problem with the module. See electrical schematic in either the HFR Repair-Parts manual.</p> <p>Replace tank RTD.</p> <p>Replace blanket heater RTD.</p> <p>Replace blanket heater.</p> <p>Replace FCM</p>

Problem	Cause	Solution
<p>Material is not cooling.</p>	<p>Chiller control solenoid not working.</p> <p>Intermittent electrical connections.</p> <p>Material temperature variations.</p> <p>FCM errors.</p>	<p>Ensure the system main power is ON.</p> <p>Ensure all electrical connections to the chiller control solenoid are secure. See electrical schematic in either the HFR Repair-Parts manual.</p> <p>Ensure the tank RTD connections are secure. See electrical schematic in either the HFR Repair-Parts manual.</p> <p>Check FCM circuit breaker in base cube to see if it has tripped. See electrical schematic in either the HFR Repair-Parts manual.</p> <p>Check tank stand circuit breaker in GMS power distribution box to see if it has tripped. See electrical schematic in either the HFR Repair-Parts manual.</p> <p>Check FCM. A red LED indicates a problem with the module. See electrical schematic in either the HFR Repair-Parts manual.</p> <p>Replace tank RTD.</p> <p>Replace chiller control solenoid.</p> <p>Replace FCM.</p>

Problem	Cause	Solution
<p>Level sensor is not sensing material when material is present.</p> <p>Level sensor is sensing material when material is not present.</p>	<p>Level sensors out of calibration.</p> <p>Level sensors blocked inside tank.</p> <p>Intermittent electrical connections.</p> <p>FCM errors.</p>	<p>Ensure the system main power is ON.</p> <p>Calibrate level sensor.</p> <p>Check inside tank to ensure there is nothing blocking the level sensor.</p> <p>Ensure all electrical connections to the level sensor are secure. See electrical schematic in either the HFR Repair-Parts manual.</p> <p>Check FCM circuit breaker in base cube to see if it has tripped. See electrical schematic in either the HFR Repair-Parts manual.</p> <p>Check tank stand circuit breaker in GMS power distribution box to see if it has tripped. See electrical schematic in either the HFR Repair-Parts manual.</p> <p>Check FCM. A red LED indicates a problem with the module. See electrical schematic in either the HFR Repair-Parts manual.</p> <p>Replace level sensor.</p> <p>Replace FCM.</p>

Problem	Cause	Solution
<p>Tank is not refilling.</p>	<p>Air solenoid valve not operating.</p> <p>Leaking or damaged air lines.</p> <p>Intermittent electrical connections.</p> <p>Level sensors out of calibration.</p> <p>Supply/feed system is off or empty.</p>	<p>Check the material supply feed to the tank.</p> <p>Check inside tank to ensure there is nothing blocking the level sensor.</p> <p>Ensure the main air to tank connections are secure.</p> <p>Ensure the air lines from the air solenoid valve to the fill valve or feed pump are securely connected and that there are no leaks.</p> <p>Ensure all electrical connections to the air solenoid valve are secure. See electrical schematic in either the HFR Repair-Parts manual.</p> <p>Ensure the air solenoid valve is operating by removing the outgoing air line to determine if air is flowing.</p> <p>Check FCM. A red LED indicates a problem with the module. See electrical schematic in either the HFR Repair-Parts manual.</p> <p>Replace air solenoid valve.</p> <p>Replace level sensor.</p> <p>Replace fill valve.</p> <p>Replace feed pump.</p> <p>Replace FCM.</p>

Problem	Cause	Solution
<p>Tank is overfilling.</p>	<p>Level sensors out of calibration.</p> <p>Level sensors blocked inside tank.</p> <p>Intermittent electrical connections.</p>	<p>Calibrate level sensors.</p> <p>Check inside tank to ensure there is nothing blocking the level sensor.</p> <p>Ensure the main air to tank connections are secure.</p> <p>Ensure the air lines from the air solenoid valve to the fill valve or feed pump are securely connected and that there are no leaks.</p> <p>Ensure all electrical connections to the air solenoid valve are secure. See electrical schematic in either the HFR Repair-Parts manual.</p> <p>Ensure the air solenoid valve is operating by removing the outgoing air line to determine if air is flowing.</p> <p>Check FCM. A red LED indicates a problem with the module. See electrical schematic in either the HFR Repair-Parts manual.</p> <p>Replace air solenoid valve.</p> <p>Replace level sensor.</p> <p>Replace fill valve.</p> <p>Replace feed pump.</p> <p>Replace FCM.</p>



Problem	Cause	Solution
<p>System is not circulating material.</p>	<p>Bypass valve damaged or not operating.</p> <p>Material hoses incorrectly connected.</p> <p>Material hose leakage.</p>	<p>Ensure the system main power is ON.</p> <p>Ensure the main air to tank connections are secure.</p> <p>Ensure the air lines from the bypass air solenoid valve to the bypass valve are securely connected and that there are no leaks.</p> <p>Ensure all electrical connections to the bypass air solenoid valve are secure. See electrical schematic in either the HFR Repair-Parts manual.</p> <p>Ensure the bypass air solenoid valve is operating by removing the outgoing air line to determine if air is flowing.</p> <p>Check FCM. A red LED indicates a problem with the module. See electrical schematic in either the HFR Repair-Parts manual.</p> <p>Check tank stand circuit breaker in GMS power distribution box to see if it has tripped. See electrical schematic in either the HFR Repair-Parts manual.</p> <p>Replace bypass valve.</p> <p>Replace bypass air solenoid valve.</p>

<b>Problem</b>	<b>Cause</b>	<b>Solution</b>
<p>Tank stand module is not communicating with system.</p>	<p>Intermittent electrical connections.</p> <p>FCM errors.</p>	<p>Ensure the system main power is ON.</p> <p>Ensure power disconnect on base cube is ON.</p> <p>Ensure all power and communication connections from the GMS system to the tank stand are secure. See electrical schematic in either the HFR Repair-Parts manual.</p> <p>Check tank stand circuit breaker in GMS power distribution box to see if it has tripped. See electrical schematic in either the HFR Repair-Parts manual.</p> <p>Check FCM. A red LED indicates a problem with the module. See electrical schematic in either the HFR o Repair-Parts manual.</p> <p>Replace power cable.</p> <p>Replace communications cable.</p>

# Repair

## Replace Agitator Fuse

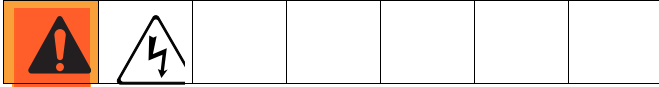

1. Turn off main power.
2. Slide open the fuse drawer.
3. Remove old fuse and replace with new fuse.

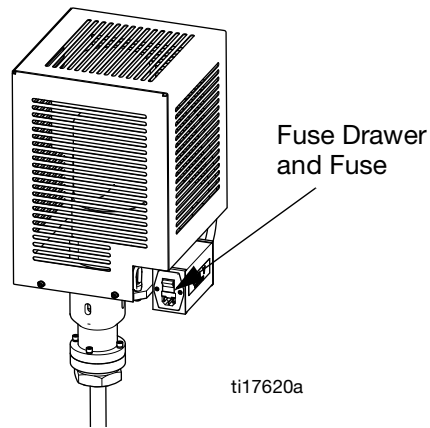

**FIG. 15: Agitator Fuse**

## Tank Lid Gasket

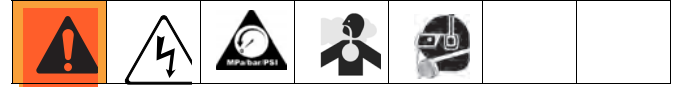

If the tank includes an agitator, use a capable hoist to lift the tank lid and agitator assembly out of the day tank.

### Tools/Supplies Required:

- Hoist (if an agitator is installed)
  - Drop cloth
  - Crescent wrench
  - 3 ft. x 3 ft. air tight plastic sheet and removable tape
  - Screwdriver
  - Lithium o-ring grease
1. Turn off main power.
  2. Relieve tank air pressure. See **Pressure Relief Procedure**, page 17.
  3. Use a drop cloth to set the tank lid assembly on.
  4. Remove pressurized air supply tubing from tank air pressure inlet. Press on locking collar and pull out the tube.
  5. Use a crescent wrench to loosen all of the bolts (CE) on the tank lid (B) in a cross-wise pattern.

- Lift the tank lid assembly (B) off of the tank and set on the drop cloth.

Damage to the level sensors may occur when there is an agitator installed and the lid is removed. To avoid damage to level sensors, remove the tank lid assembly while keeping the agitator away from the level sensor assemblies.

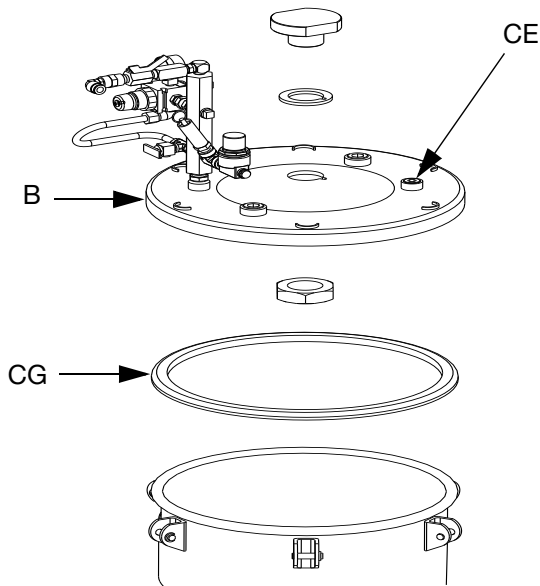

r\_24c317\_3A0395a\_6a

**FIG. 16: Tank Lid**

- Use an air tight plastic sheet and removable tape to cover the day tank opening. Tape the sheet in place.
- Use a screwdriver to remove the tank lid gasket (CG, part 117571) from the groove on the bottom of the tank lid.
- Apply lithium grease to the new tank lid gasket and press the gasket into the groove.
- Remove air tight plastic sheet and tape from tank.
- Replace the tank lid (B) and new gasket onto the day tank.
- Hand-tighten the bolts onto the lid. Then use a crescent wrench to tighten the bolts (CE) in a cross-wise pattern.
- Re-attach pressurized air supply tubing by pressing in on locking collar and sliding in the tube.
- With air pressure now supplied to the tank, purge the moist air from the tank by opening the air purge valve on the tank lid for 60 seconds.
- Turn on main power and run the machine for 30 minutes to circulate material.

## Level Sensor and Well

For proper level sensor function, the tip of the level sensor well must protrude at least 1/8 in. into the tank (C).

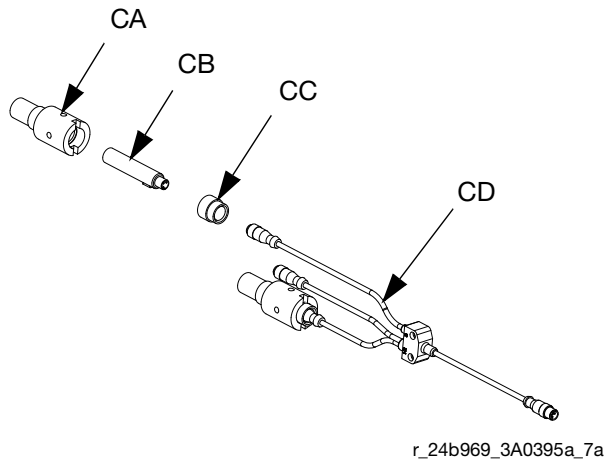

**Fig. 17: Level Sensor Assembly**

1. Turn main power off.
2. Relieve tank air pressure. See **Pressure Relief Procedure**, page 17.
3. Drain tanks to below level sensor well.
4. Unscrew level sensor harness cable (CD) from level sensor well housing (CA).
5. Use a crescent wrench to remove level sensor well housing from tank (C).
6. Remove the old level sensor (CB) from well housing.
7. Measure the length of the level sensor well housing, and then measure the depth of the hole in the tank where the well is inserted. Note these measurements as they will be needed later.
8. Being careful to not cross-threads, thread assembled level sensor (CB) into well housing until it bottoms out against the bottom of the well. The bottom of the level sensor will be slightly visible through the bottom of the well.

In the following step, do not allow PTFE paste or tape to cover the tip of the level sensor well. If paste comes in contact with the tip of the level sensor well, thoroughly wipe it clean.

9. Apply PTFE paste and PTFE tape to the male threads of the level sensor well housing.
10. Being careful to not cross-threads, thread the level sensor well into the tank (C) and lightly tighten with a crescent wrench.
11. Measure the amount of the level sensor well housing that is visible beyond the day tank hole, then perform the following equation:

$$P = L1 - (L2 + L3)$$

P = Protrusion length (inside of day tank)  
 L1 = Length of level sensor well (A10)  
 L2 = Visible length of level sensor well  
 L3 = Length of well threads in day tank

12. The protrusion length must be at least 1/8 in. (3.2 mm). If not, remove the level sensor well and restart at step 7.
13. Rotate level sensor to optimal position for wire routing and connect cable to connector.

# Electrical Schematics

## Electrical Panel, Tank Stand with Agitator, Heater/Chiller

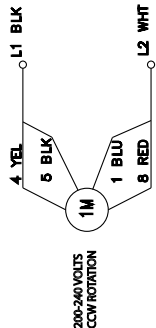
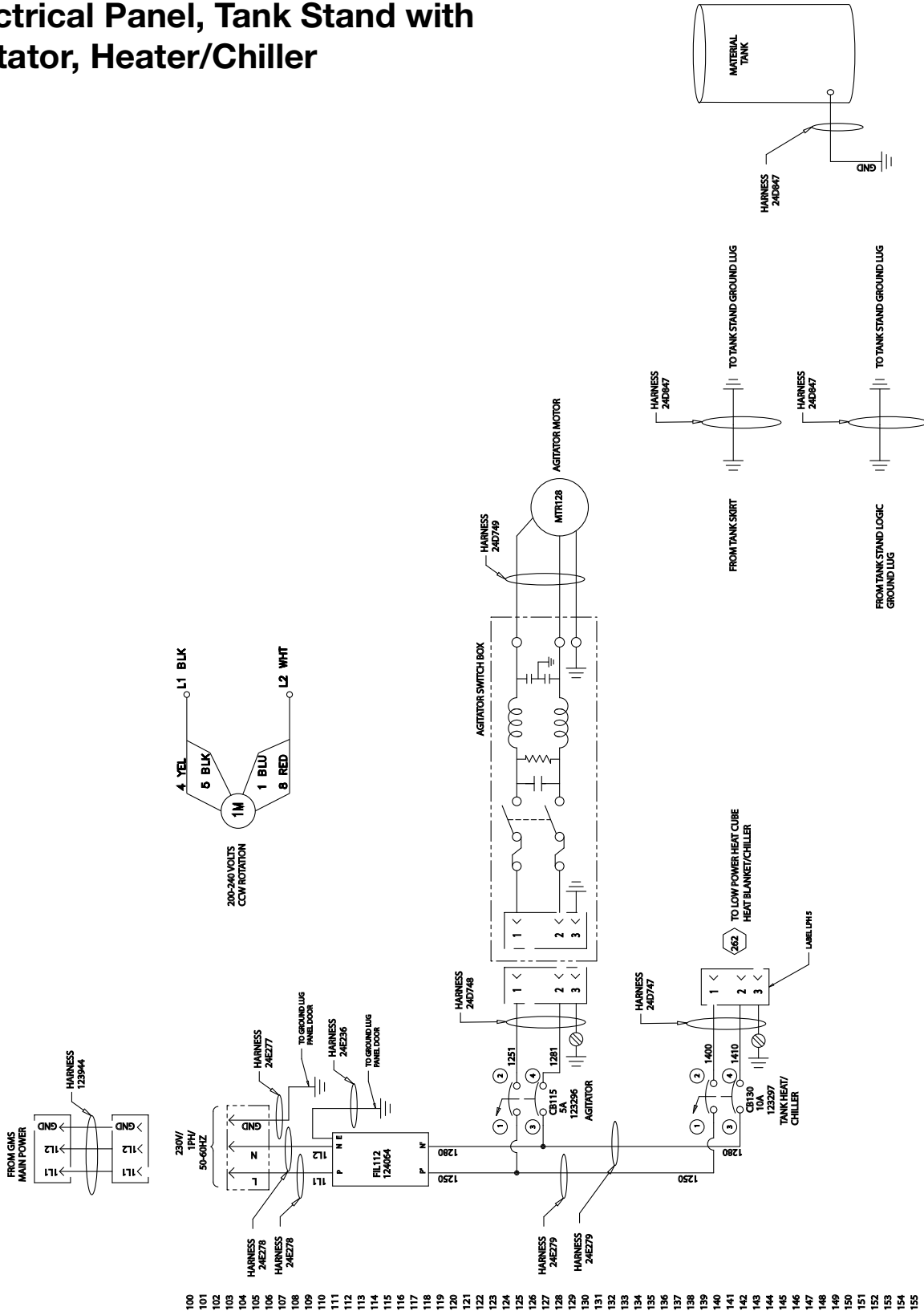

- 100
- 101
- 102
- 103
- 104
- 105
- 106
- 107
- 108
- 109
- 110
- 111
- 112
- 113
- 114
- 115
- 116
- 117
- 118
- 119
- 120
- 121
- 122
- 123
- 124
- 125
- 126
- 127
- 128
- 129
- 130
- 131
- 132
- 133
- 134
- 135
- 136
- 137
- 138
- 139
- 140
- 141
- 142
- 143
- 144
- 145
- 146
- 147
- 148
- 149
- 150
- 151
- 152
- 153
- 154
- 155

Continued

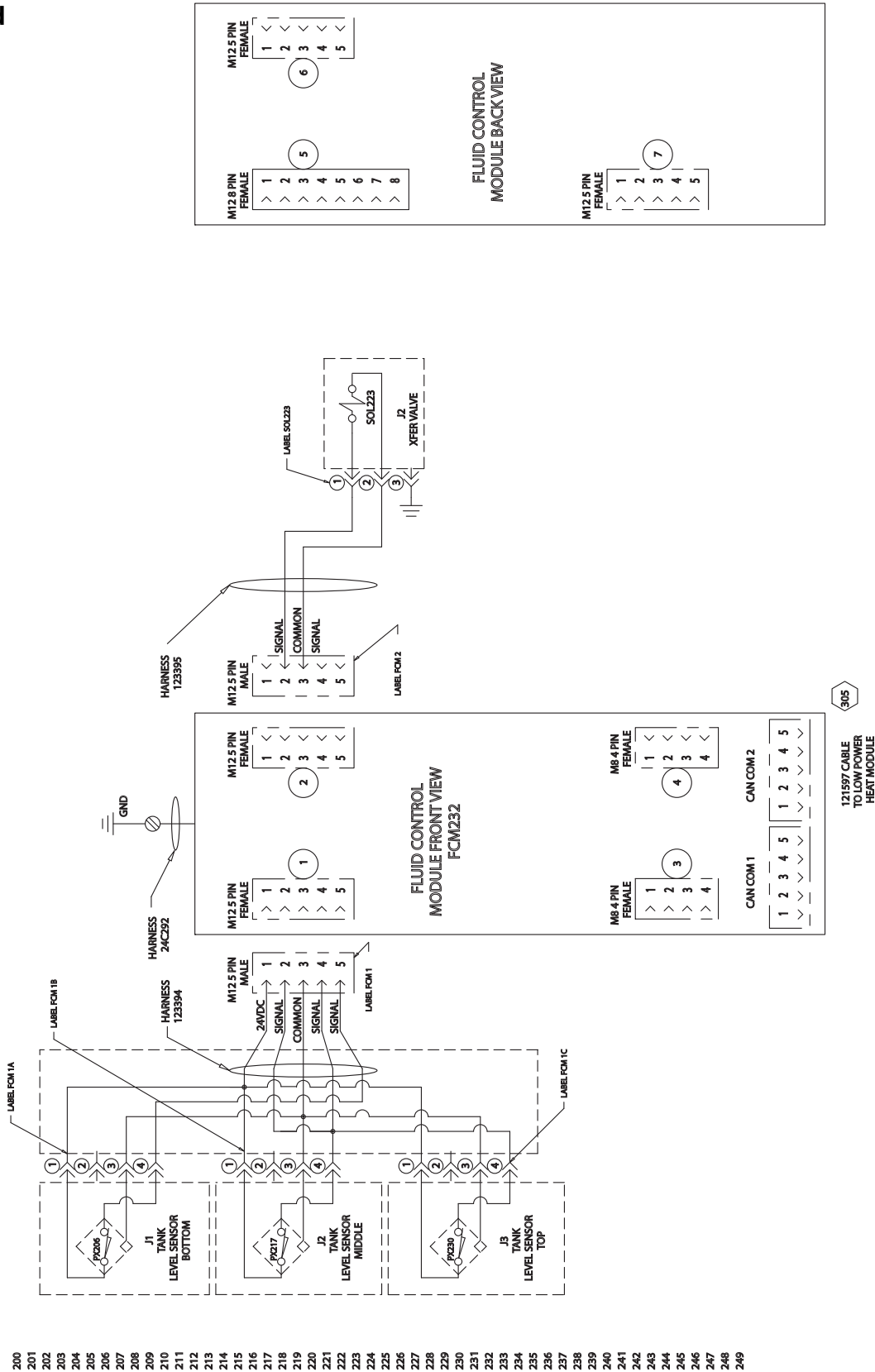

200  
201  
202  
203  
204  
205  
206  
207  
208  
209  
210  
211  
212  
213  
214  
215  
216  
217  
218  
219  
220  
221  
222  
223  
224  
225  
226  
227  
228  
229  
230  
231  
232  
233  
234  
235  
236  
237  
238  
239  
240  
241  
242  
243  
244  
245  
246  
247  
248  
249





Continued

300  
301  
302  
303  
304  
305  
306  
307  
308  
309  
310  
311  
312  
313  
314  
315  
316  
317  
318  
319  
320  
321  
322  
323  
324  
325  
326  
327  
328  
329  
330  
331  
332  
333  
334  
335  
336  
337  
338  
339  
340  
341  
342  
343  
344  
345  
346  
347  
348  
349  
350

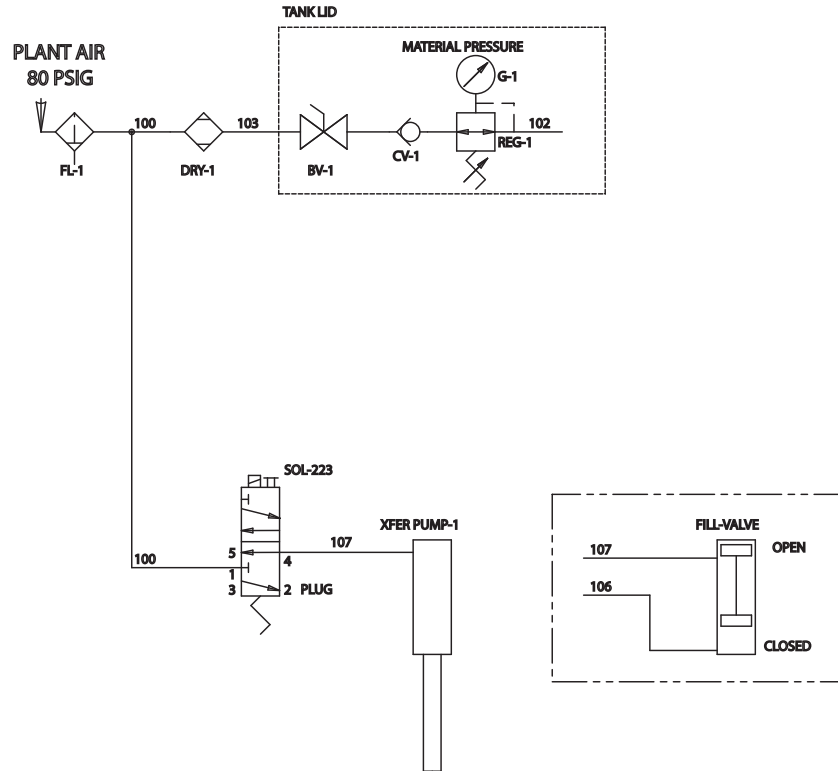

# Electrical Panel, Tank Stand with Agitator

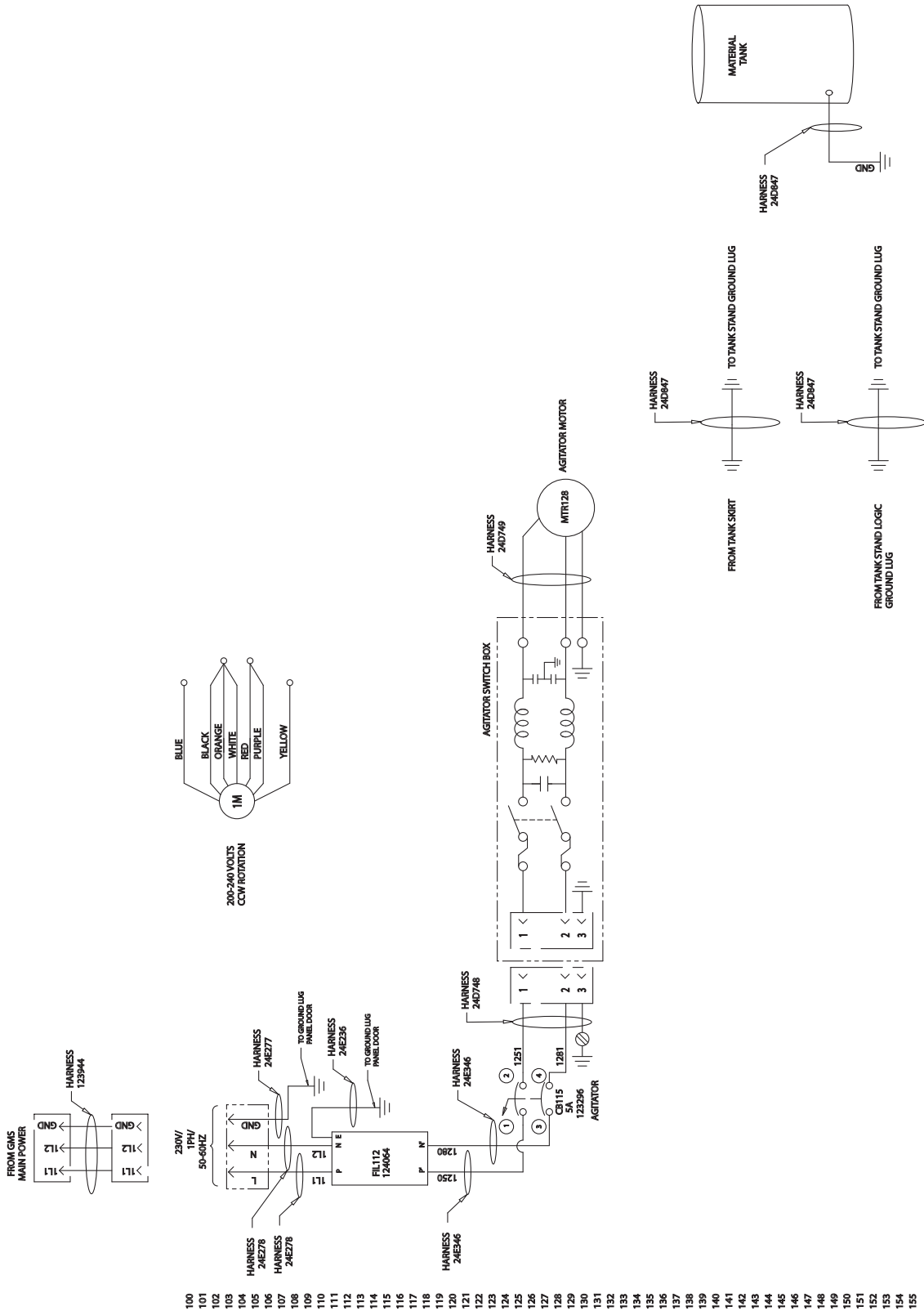

Continued

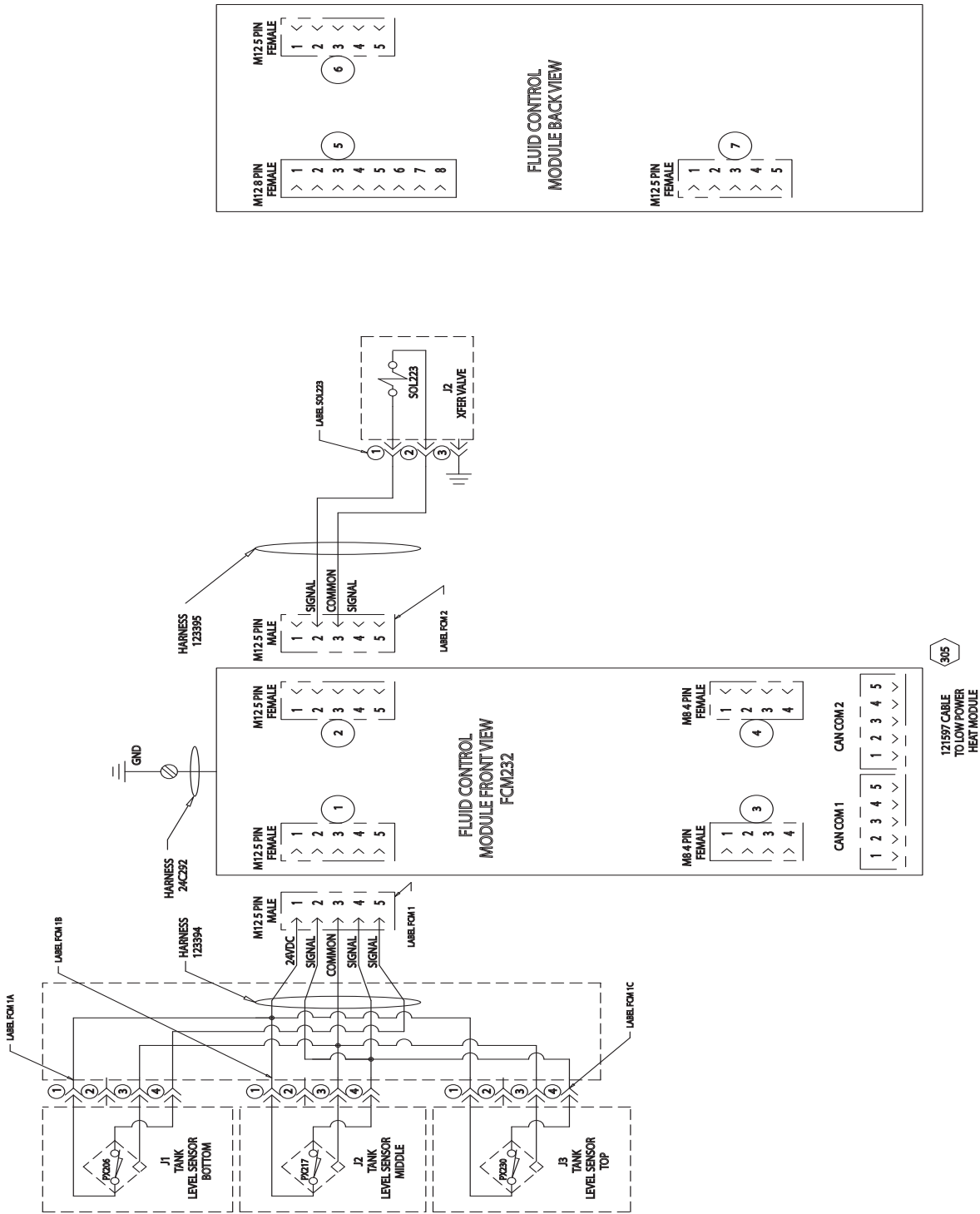

200  
201  
202  
203  
204  
205  
206  
207  
208  
209  
210  
211  
212  
213  
214  
215  
216  
217  
218  
219  
220  
221  
222  
223  
224  
225  
226  
227  
228  
229  
230  
231  
232  
233  
234  
235  
236  
237  
238  
239  
240  
241  
242  
243  
244  
245  
246  
247  
248  
249

Continued

300  
301  
302  
303  
304  
305  
306  
307  
308  
309  
310  
311  
312  
313  
314  
315  
316  
317  
318  
319  
320  
321  
322  
323  
324  
325  
326  
327  
328  
329  
330  
331  
332  
333  
334  
335  
336  
337  
338  
339  
340  
341  
342  
343  
344  
345  
346  
347  
348  
349  
350

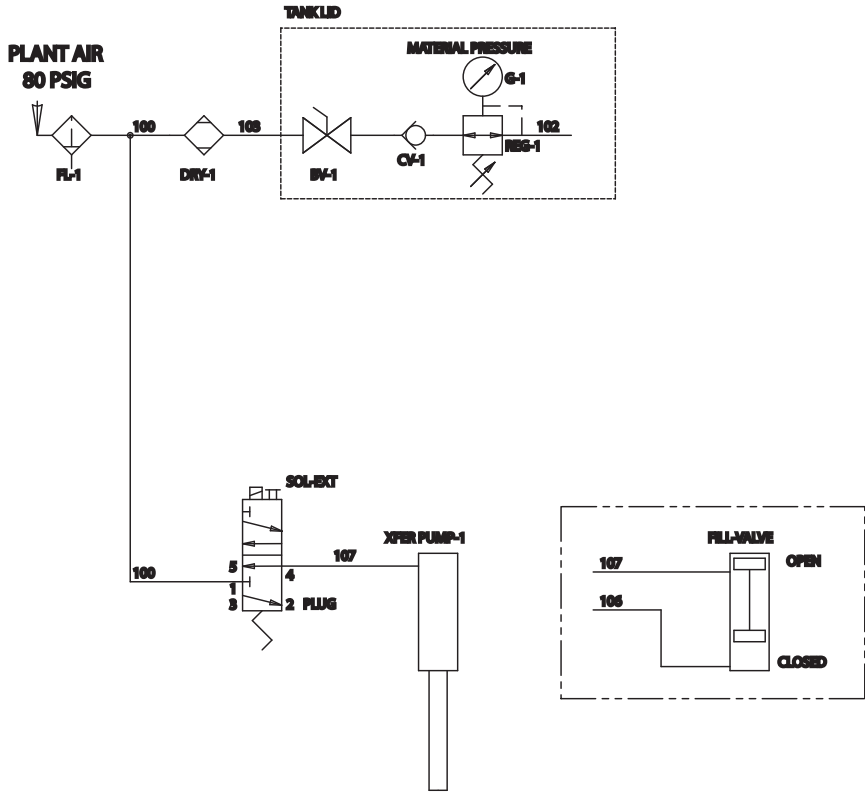

# Parts

## 38L and 75L Tank Modules

Ref. 4 Shown

 Mounting screws supplied with assembly.

Front View Shown

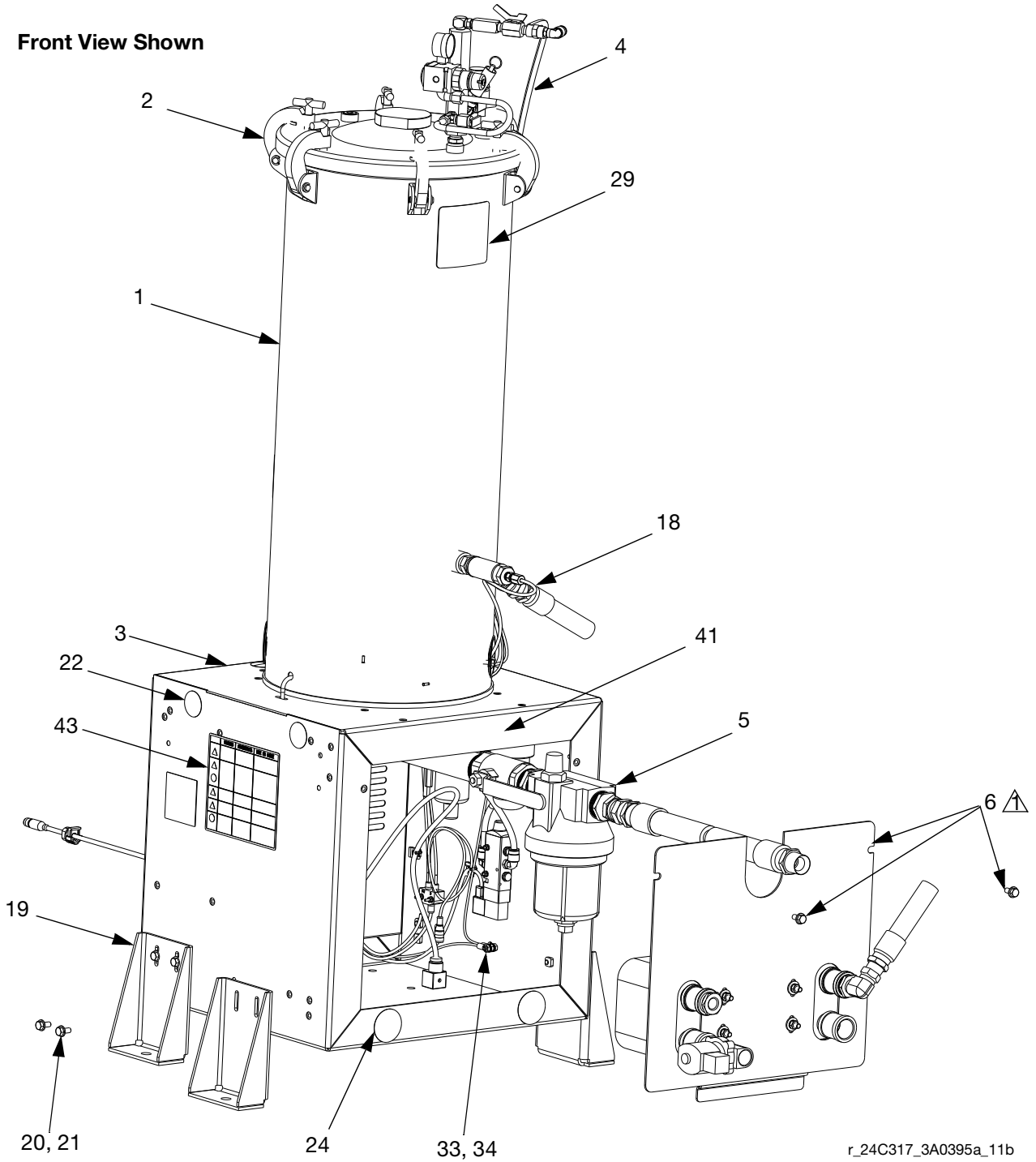

r\_24C317\_3A0395a\_11b



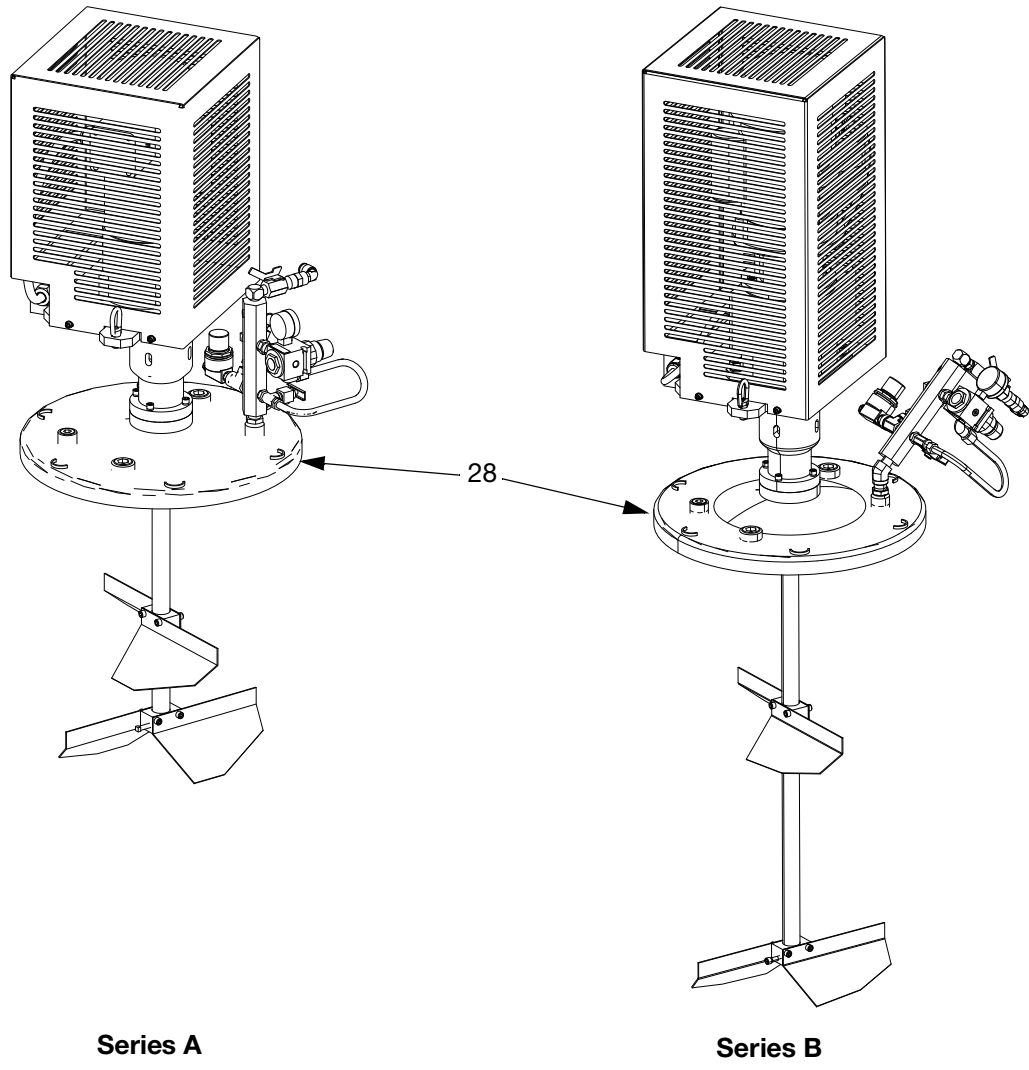

## 38L and 75L Tank Module Parts

The following tables on this and the next three pages list the varying part numbers, common part numbers, and quantities by tank module assembly.

Ref	Part	Description	Tank Module and Quantity							
			24C317	24D562	24D564	24D565	24D568	24D569	24D570	24D571
1	★	TANK, assy, 38L, sst		1	1		1	1	1	1
		TANK, assy, 75L, sst	1			1				
	★	TANK, assy, heat, 38L, sst								
	★	TANK, assy, heat, 75L, sst								
2		LID, assy, 38L/75L, rim	1	1	1	1	1	1	1	
	★	LID, assy, agitator, vac degas, fill								1
3		ENCLOSURE, frame	1	1	1	1	1	1	1	1
4		LID, assy, plug, 38L/75L, rim		1		1	1	1		
	★	LID, assy, 38L, agitator, rim			1				1	1
		LID, assy, 75L, agitator, rim	1							
5		VALVE, assy, ball; 1-1/2 npt, sst (filter)	1	1	1	1				
	★	VALVE, assy, ball; 1-1/2 npt, sst					1	1	1	1
6	24D852★	COVER, assy, tank stand					1	1	1	1
		EXCHANGER, assy, heat, tank, single	1	1	1	1				
7	★	COVER, enclosure, slotted, assy					1			
		PANEL, assy, electric, tank, agit/heat	1	1	1	1				
	★	PANEL, assy, electric, tank, agit						1	1	1
8	24C157	VALVE, assy, power, tank, transfer pump	1	1	1	1		1	1	1
10		FILTER, dryer, assy, tank	1	1	1	1	1	1	1	1
11		SWITCH, assy, level, 2 prox	1	1	1	1		1	1	1
12	117683	SCREW, mach, pan head	4	4	4	4	4	4	4	4
13	107016	WASHER, plain	8	8	8	8	8	8	8	8
14	100072	NUT, hex mscr	4	4	4	4	4	4	4	4
15	100079	WASHER, lock, spring	4	4	4	4	4	4	4	4



Ref	Part	Description	Tank Module and Quantity							
			24C317	24D562	24D564	24D565	24D568	24D569	24D570	24D571
16		FITTING, assy, bulkhead; 1/4 npt	1	1	1	1	1	1	1	1
17		GUARD, trim, edge	29	29	29	29	29	29	29	29
18		PROBE, assy, recirculation, heat exchange	1	1	1	1				
19	24D021	BRACKET, anchor	4	4	4	4	4	4	4	4
20	111800	SCREW, cap, hex head	8	8	8	8	8	8	8	8
22	123398	PLUG, hole; 1.5 in. dia.	5	5	5	5	6	5	5	5
23	123679	BUSHING, wire protector, snap-in	3	3	3	3	2	2	2	2
24	123590	PLUG, hole; 2 in. dia.	2	2	2	2	2	2	2	2
25	123944	HARNESS, power cord, tank stand; 20A	1	1	1	1	1	1	1	1
26	124003	CABLE, CAN, male-female, 5 m	1	1	1	1	1	1	1	1
27	122005	BUSHING, strain relief	1	1	1	1	1	1	1	1
28	257606	PLATE, slinger, 38L/75L								1
29	15G476	LABEL, identification	1	1	1	1	1	1	1	1
30★	123395	HARNESS, power, valve	1	1	1	1				
33	100015	NUT, hex	3	3	3	3	3	3	3	3
34	100985	WASHER, lock	4	4	4	4	4	4	4	4
35	116610	SCREW, mach, pan	4	4	4	4		4	4	4
36	123452	HOLDER, anchor	4	4	4	4		4	4	4
37	100020	WASHER, lock	4	4	4	4		4	4	4
38	100016	NUT, full hex	4	4	4	4		4	4	4
41▲	196548	LABEL, caution	1	1	1	1	1	1	1	1
43▲	15M511	LABEL, warning	1	1	1	1	1	1	1	1

★ Not shown.

▲ Replacement Danger and Warning labels, tags, and cards are available at no cost.

**38L and 75L Tank Module Parts (continued)**

Ref	Part	Description	Tank Module and Quantity									
			24D572	24D573	24D574	24D575	24D576	24D577	24D578	24D579	24P091	
1	★	TANK, assy, 38L, sst										
		TANK, assy, 75L, sst			1	1	1	1				1
	★	TANK, assy, heat, 38L, sst	1	1								
	★	TANK, assy, heat, 75L, sst							1	1	1	
2		LID, assy, 38L/75L, rim		1	1	1	1			1	1	1
	★	LID, assy, agitator, vac degas, fill	1						1	1		1
3		ENCLOSURE, frame	1	1	1	1	1	1	1	1	1	1
4		LID, assy, plug, 38L/75L, rim			1	1						
	★	LID, assy, 38L, agitator, rim	1	1								
		LID, assy, 75L, agitator, rim					1	1	1	1	1	
5	★	VALVE, assy, ball; 1-1/2 npt, sst	1	1	1	1	1	1	1	1	1	1
6	24D852	COVER, assy, tank stand	1	1	1	1	1	1	1	1	1	1
		EXCHANGER, assy, heat, tank, single										
7	★	COVER, enclosure, slotted, assy			1							1
		PANEL, assy, electric, tank, agit/heat	1	1					1	1	1	
	★	PANEL, assy, electric, tank, agit				1	1	1				
8	24C157	VALVE, assy, power, tank, transfer pump	1	1		1	1	1	1	1	1	1
10		FILTER, dryer, assy, tank	1	1	1	1	1	1	1	1	1	1
11		SWITCH, assy, level, 2 prox	1	1		1	1	1	1	1		
	★	24F519 KIT, level sensor, high temperature									3	
		164651 Rod, displacement										3
12	117683	SCREW, mach, pan head	4	4	4	4	4	4	4	4	4	4
13	107016	WASHER, plain	8	8	8	8	8	8	8	8	8	8
14	100072	NUT, hex mscr	4	4	4	4	4	4	4	4	4	4
15	100079	WASHER, lock, spring	4	4	4	4	4	4	4	4	4	4

Ref	Part	Description	Tank Module and Quantity									
			24D572	24D573	24D574	24D575	24D576	24D577	24D578	24D579	24P091	
16		FITTING, assy, bulkhead; 1/4 npt	1	1	1	1	1	1	1	1	1	1
17		GUARD, trim, edge	29	29	29	29	29	29	29	29	29	29
18		PROBE, assy, recirculation, heat exchange										
	24J694	MODULE, assy, tank, recirc										1
19	24D021	BRACKET, anchor	4	4	4	4	4	4	4	4	4	4
20	111800	SCREW, cap, hex head	8	8	8	8	8	8	8	8	8	8
22	123398	PLUG, hole; 1.5 in. dia.	5	5	6	5	5	5	5	5	5	5
23	123679	BUSHING, wire protector, snap-in	3	3	3	3	3	3	3	3	3	3
24	123590	PLUG, hole; 2 in. dia.	2	2	2	2	2	2	2	2	2	2
25	123941	HARNESS, power cord, tank stand; 20A	1	1	1	1	1	1	1	1	1	
26	124003	CABLE, CAN, male-female, 5 m	1	1	1	1	1	1	1	1	1	1
27	124005	BUSHING, strain relief	1	1	1	1	1	1	1	1	1	1
28	257606	PLATE, slinger, 38L/75L	1					1	1			
29	15G476	LABEL, identification	1	1	1	1	1	1	1	1	1	1
30★	123395	HARNESS, power, valve									1	1
33	100015	NUT, hex	3	3	3	3	3	3	3	3	3	3
34	100985	WASHER, lock	4	4	4	4	4	4	4	4	4	4
35	116610	SCREW, mach, pan	4	4		4	4	4	4	4	4	4
36	123452	HOLDER, anchor	4	4		4	4	4	4	4	4	4
37	100020	WASHER, lock	4	4		4	4	4	4	4	4	4
38	100016	NUT, full hex	4	4		4	4	4	4	4	4	4
41▲	196548	LABEL, caution	1	1	1	1	1	1	1	1	1	1
43▲	15M511	LABEL, warning	1	1	1	1	1	1	1	1	1	1
44★	123394	HARNESS, sensor, level, tank, (3)									1	1
45★	125388	BLANKET										1
46★	125325	HARNESS										3
47★	119992	FITTING										1
48★	122327	FITTING										1
49★	125610	VALVE, ball										1

★ Not shown.

▲ Replacement Danger and Warning labels, tags, and cards are available at no cost.

## 2 Gallon Tank Module - 24J243

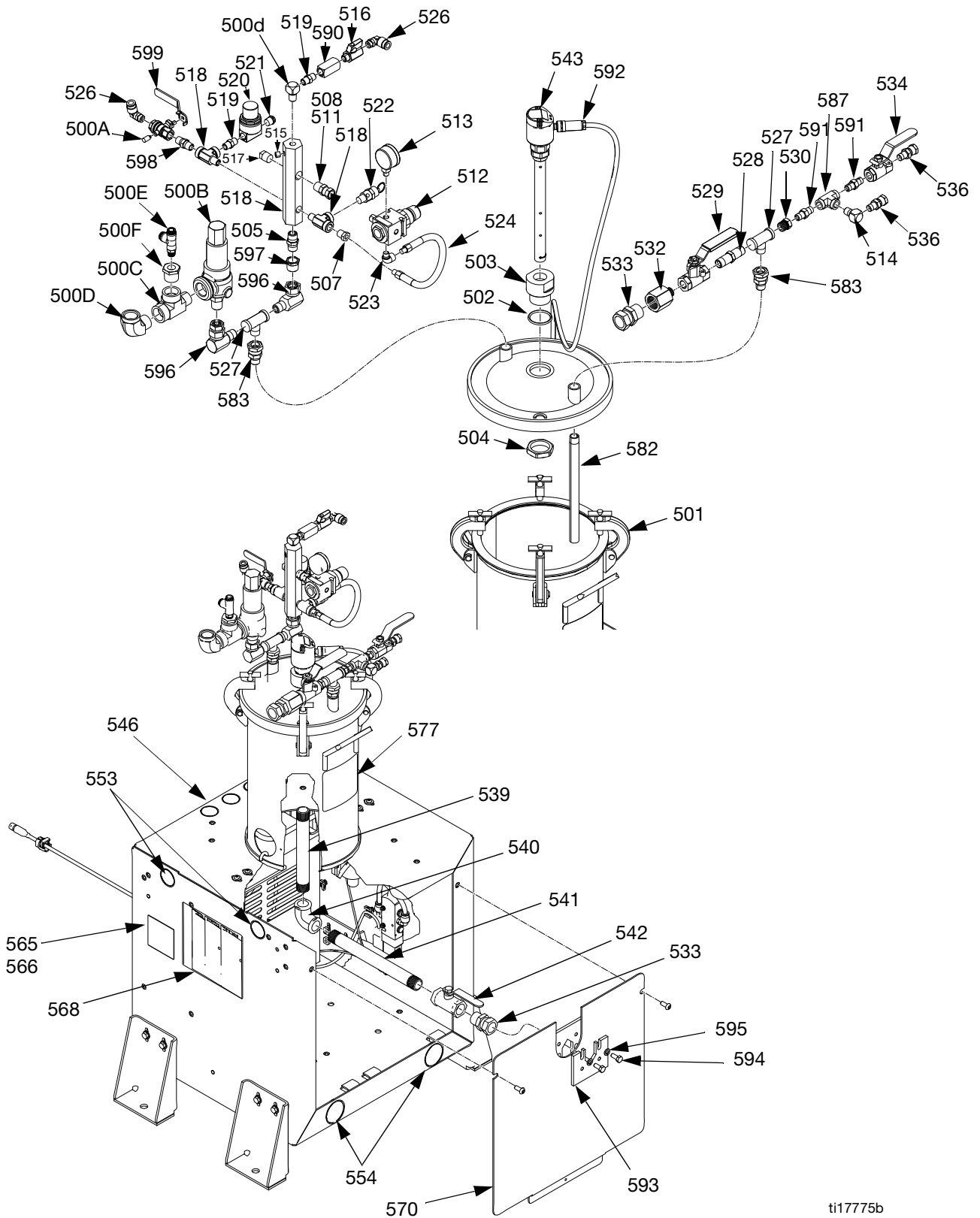

ti17775b

### 2 Gallon Tank Module (continued)

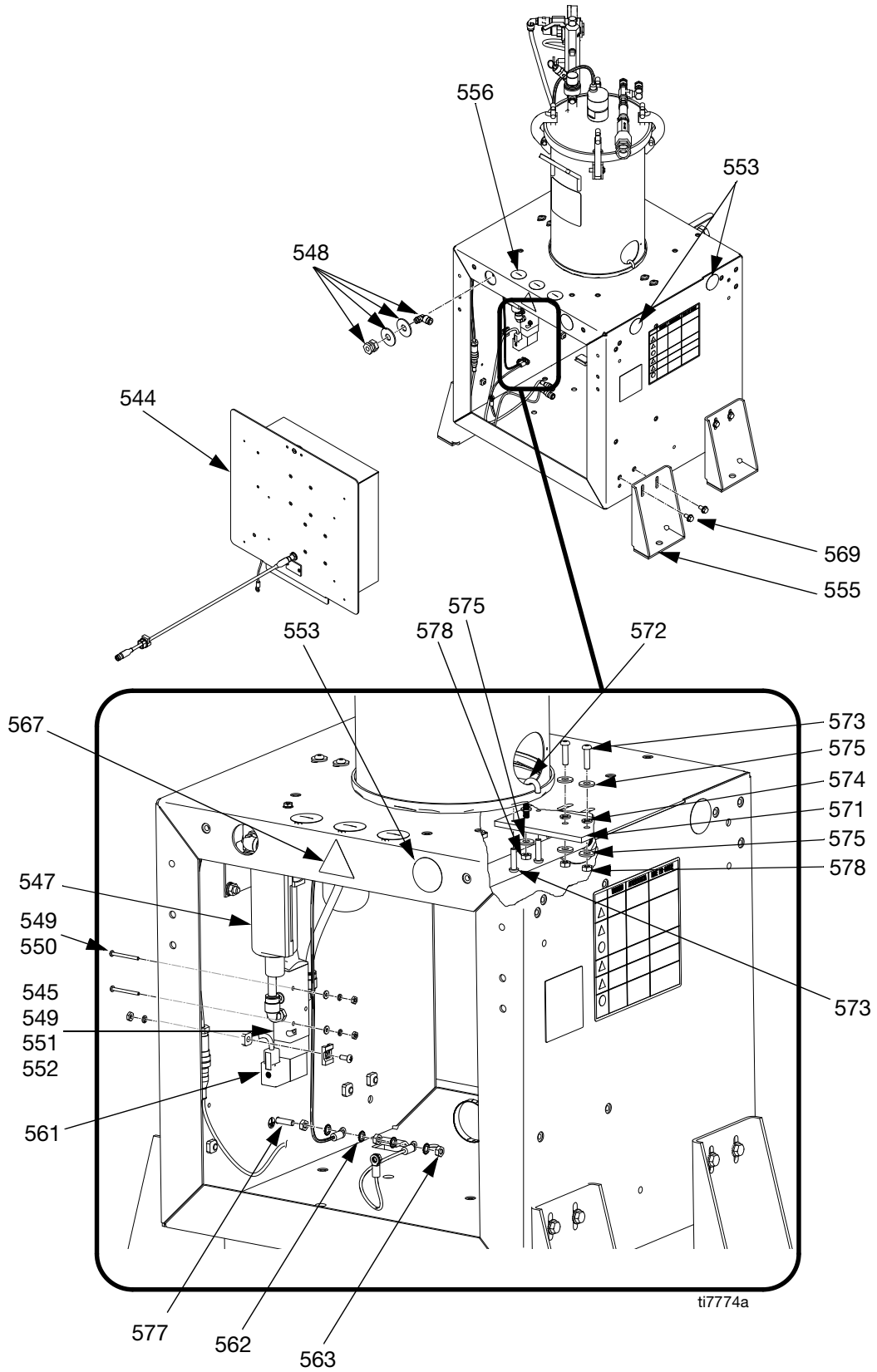

**2 Gal Tank Module (continued)**

Ref.	Part	Description	Qty.	Ref.	Part	Description	Qty.
501	236086	TANK, pressure assy, 2 gal	1	★557	123452	HOLDER, anchor, wire tie, nylon	4
502	125312	PACKING, o-ring	1	★558	116610	SCREW, mach, phil, pan, #10	4
503	16H698	ADAPTER, sensor, ultrasonic	1	★559	100020	WASHER, lock	4
504	188784	NUT, jam, hex	1	★560	100166	NUT, full hex	4
505	156849	PIPE, nipple	1	561	123395	HARNES, pwr valve, tank	1
506	189016	MANIFOLD, air, inlet	1	★564	24D847	HARNES, ground, tank	1
507	100030	BUSHING	1	565	16D782	BLANK, label, kit, 3x3	1
508	110476	ADAPTER, union, straight swivel	1	▲567	196548	LABEL, caution	1
509	110475	FITTING, street, tee	1	▲568	15M511	LABEL, warning, eng/span/fre	1
510	101759	FITTING, drain cock	1	569	111800	SCREW, cap, hex hd	8
511	151519	FITTING, nipple, reducing	1	570	24D852	COVER, assy, tank stand, blank	1
512	110341	REGULATOR, air	1	571	16H696	PLATE, mtg, tank, 2gal	2
513	124339	GAUGE, press, 0-160psi	1	572	125221	BOLT, "j", 1/4-20	2
514	100840	FITTING, elbow, street	1	573	112689	SCREW, button hd	4
515	100139	PLUG, pipe	1	574	100016	WASHER, lock	3
516	208390	VALVE, ball	1	575	100527	WASHER, plain	5
517	104813	PLUG, pipe	1	▲577	15G476	LABEL, a-b identification	2
518	123256	FITTING, tee, 1/4npt	1	578	100015	NUT, hex mscr	3
519	123257	FITTING, nipple, hex	2	★580	123673	HARNES, ext, m12xm12	1
520	123258	FITTING, valve, bleed	1	581	123424	GUARD, trim, edge	2.5
521	121021	MUFFLER	1	582	185531	TUBE, siphon	1
522	103347	VALVE, safety, 100 psi	1	583	235208	FITTING, union, swivel	1
523	112307	ELBOW, street	1	584	155665	UNION, adapter	1
524	164724	HOSE, coupled	1	585	24C656	HOSE, coupled, 10 ft, sst	1
525	121089	FITTING, nipple	1	586	166866	FITTING, elbow, street, sst	1
526	121018	FITTING, elbow, male, swivel	1	587	124962	FITTING, tee	1
527	111928	TEE, male branch pipe	1	590	125848	VALVE, check, 1/4 npt, 250 psi, brass	1
528	191931	NIPPLE	1	591	121907	FITTING, nipple, hex, 1/4 npt, stainless steel, swivel	2
529	114243	VALVE, check	1	592	126135	HARNES, M12xM12, 8-pin x 5 pin, female x male, 1.5 meter	1
530	125214	BUSHING, hex	1	593	24N437	BRACKET, filter, 2 gallon tank	2
532	125213	ADAPTER, reducer	1	594	100057	SCREW, cap, hex head	2
533	112268	SWIVEL, union	2	595	112904	WASHER, lock, spring	2
534	501867	VALVE, check	1	596	217430	FITTING, swivel, union, 90 degree	2
536	262206	FITTING, swivel	2	597	100081	BUSHING, pipe	1
539	125217	FITTING, nipple	1	598	156971	FITTING, nipple, short	1
540	102325	FITTING, elbow, 90 degrees	1	599	110223	VALVE, 1/4 ball valve with relief	1
541	125218	FITTING, nipple	1	500A	6312-74	MUFFLER, silencer	1
542	122770	VALVE, ball	1	500B	126302	VALVE, chemical relief	1
543	24N004	SENSOR, ultrasonic, programmed	1	500C	16F259	FITTING, run tee, 3/4 npt	1
544	24H179	PANEL, gms, tank, levels only	1	500D	122327	FITTING, elbow, street	1
545	24C157	VALVE, assy, pwr, tank, xfer pump	1	500E	123376	FITTING, tee, run, 1/4 tube x 1/4 npt, brass	1
546	257965	ENCLOSURE, frame, painted	1	500F	100615	BUSHING, hex steel	1
547	24C159	FILTER, dryer, assy, tank	1				
548	24C228	FITTING, assy, bulkhead,	1				
549	107016	WASHER, plain	4				
550	117683	SCREW, mach	2				
551	100079	WASHER, lock, spring	2				
552	100072	NUT, hex mscr	2				
553	123398	PLUG, hole, 1.5" dia	5				
554	123590	PLUG, hole, 2" dia	4				
555	16A221	BRACKET, anchor	4				
556	124334	PLUG, hole, 1.375" dia, blk	3				

★ *Not shown.*▲ *Replacement Danger and Warning labels, tags, and cards are available at no cost.*

# Heated Tank Assemblies

## 38L and 75L Heated Tank Assemblies

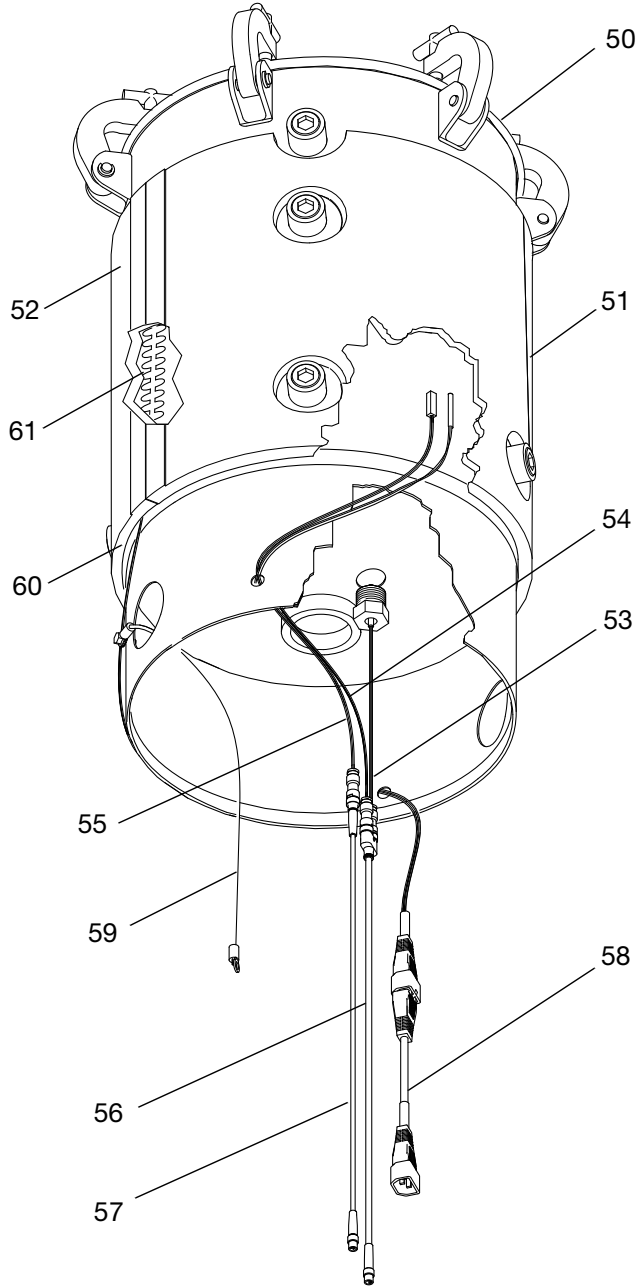

Ref.	Part	Description	Qty
50		TANK, assy.	1
	✓257762	38L, SST	
	◆257772	75L; SST	
51		INSULATOR, blanket assy.	1
	✓257757	38L	
	◆257758	75L	
52		BLANKET, assy., heat	1
	✓257760	38L, 240V	
	◆257761	75L, 240V	
53	257759	SENSOR, thermowell assy., RTD	1
54	256611	SENSOR, assy.; 1.5 in., RTD, 4-pin m8	1
55	256558	SWITCH, assy., thermal; 125c, 3p, m8	1
56	121615	HARNESS, splitter; m8, 4-pin ffm, 3m	1
57	121682	CABLE; m8, 3-pin, mf, 3 meter, molded	1
58	121599	CORD, power, v-lock; c14/c13,10A	1
59	24D847	HARNESS, ground, tank	1
60	124270	TAPE, fiberglass; 6 ft.	-
61	261076	TIE, hose lacing; 6 ft.	-

✓ 38L heated tank assemblies only.

◆ 75L heated tank assemblies only.

ti7043a

# Tank Lid Assemblies

## Series A Agitator Housing with Lid for 38L and 75 Tanks

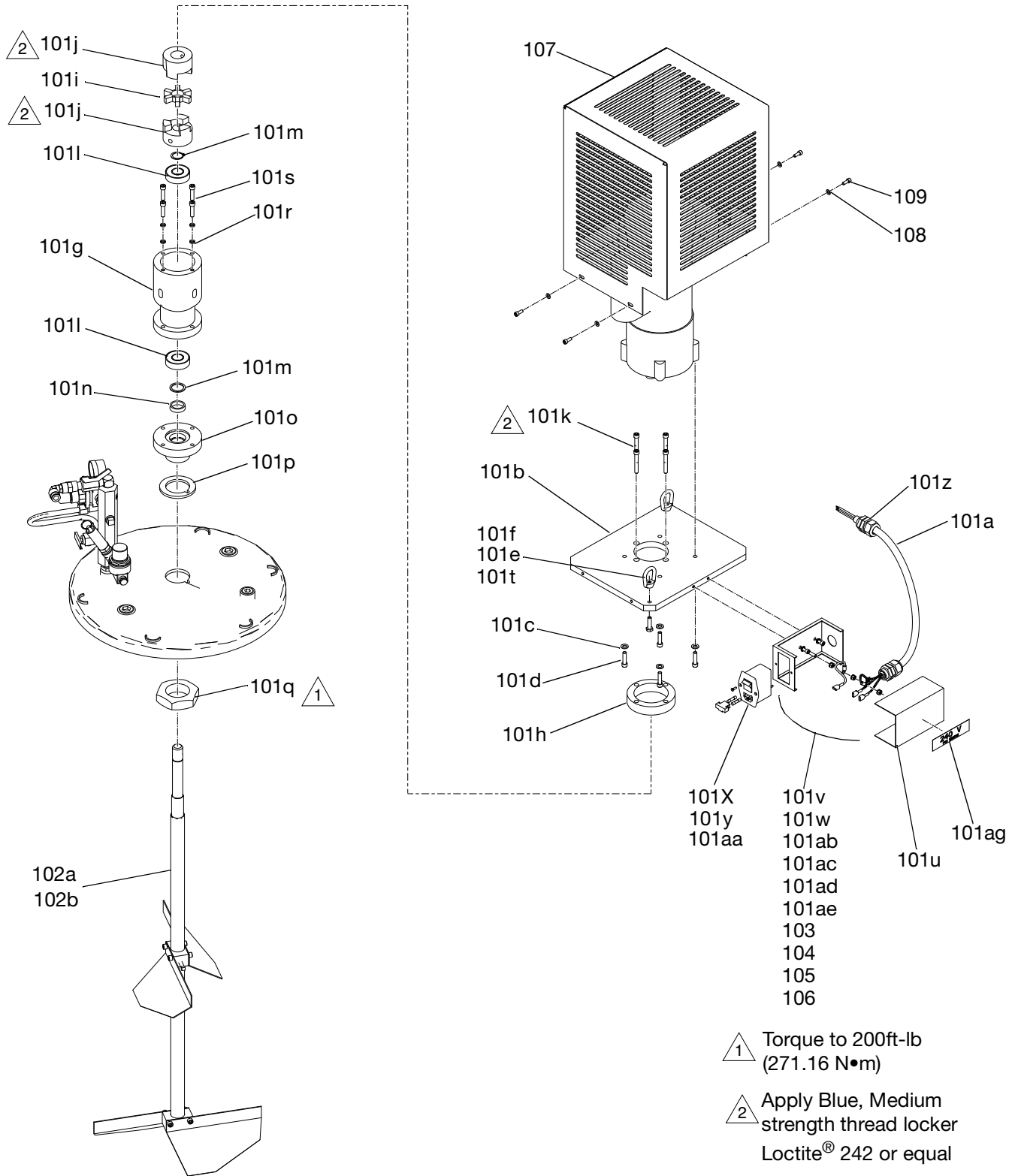



## Parts for 257605, Series A Agitator Housing with Lid for 38L and 75 Tanks

Ref	Part	Description	Qty
101a	124741	MOTOR, agitator	1
101b	---	ADAPTER, plate, agitator motor	1
101c	158223	WASHER	4
101d	108803	SCREW, hex	4
101e	100021	SCREW, cap	2
101f	122775	NUT, eye, 1/4-20	2
101g	15Y358	HOUSING, upper, agitator	1
101h	15V746	SPACER, agitator	1
101i	122760	COUPLING, alignment	1
101j	122761	COUPLER, hub	2
101k	101885	SCREW, cap	4
101l	122774	BEARING, ball	2
101m	15Y360	SPACER, seal, shaft	1
101n	122772	SEAL	1
101o	15Y357	HOUSING, lower	1
101p	15Y363	GASKET	1
101q	15Y355	NUT, shaft	1
101r	105510	WASHER, lock	4
101s	112222	SCREW, cap	4
101t	100985	WASHER, lock	2
101u	15R328	JUNCTION BOX, motor switch	1
101v	111307	WASHER, lock	2
101w	102598	SCREW, cap	2
101x	120910	SOCKET, electrical	1
101y	120916	SCREW	2
101z	121172	GRIP, cord	2
101aa	115142	FUSE, 5.0 amp, time lag	2
101ab	125008	LABEL, earth ground	1
101ac	121013	SCREW, socket head	1
101ad	120993	NUT, hex	3
101ae	24H375	HARNESS, ground	1
101af	24H376	HARNESS, power	1
101ag	15X092	LABEL, 240 volts	1
102a*	257608	BLADE, assy 75L	1
102b*	257607	BLADE, assy, 38L	1
102c*	257604	BLADE, assy,38L/75	See Table
102d*	15M625	SHAFT, blade assy 75L	See Table
102e*	15M624	SHAFT, blade assy 38L	See Table
103	122776	TERMINAL, ring	1
104	124436	CAP, splice	3
105	124437	CONNECTOR, splice	3
106	124442	TERMINAL, ring	1
107	24K356	COVER, motor	1
108	116876	WASHER	4
109	102598	SCREW, cap	4

### \* Blade Assembly Table

Blade Assembly Ref No.	Qty. Reference No. 102c	Qty. Reference No.120d	Qty. Reference No. 102e
102A	2	1	-
102B	2	-	1

▲ Replacement Danger and Warning labels, tags, and cards are available at no cost.

### 257605, Series B Agitator Housing with Lid

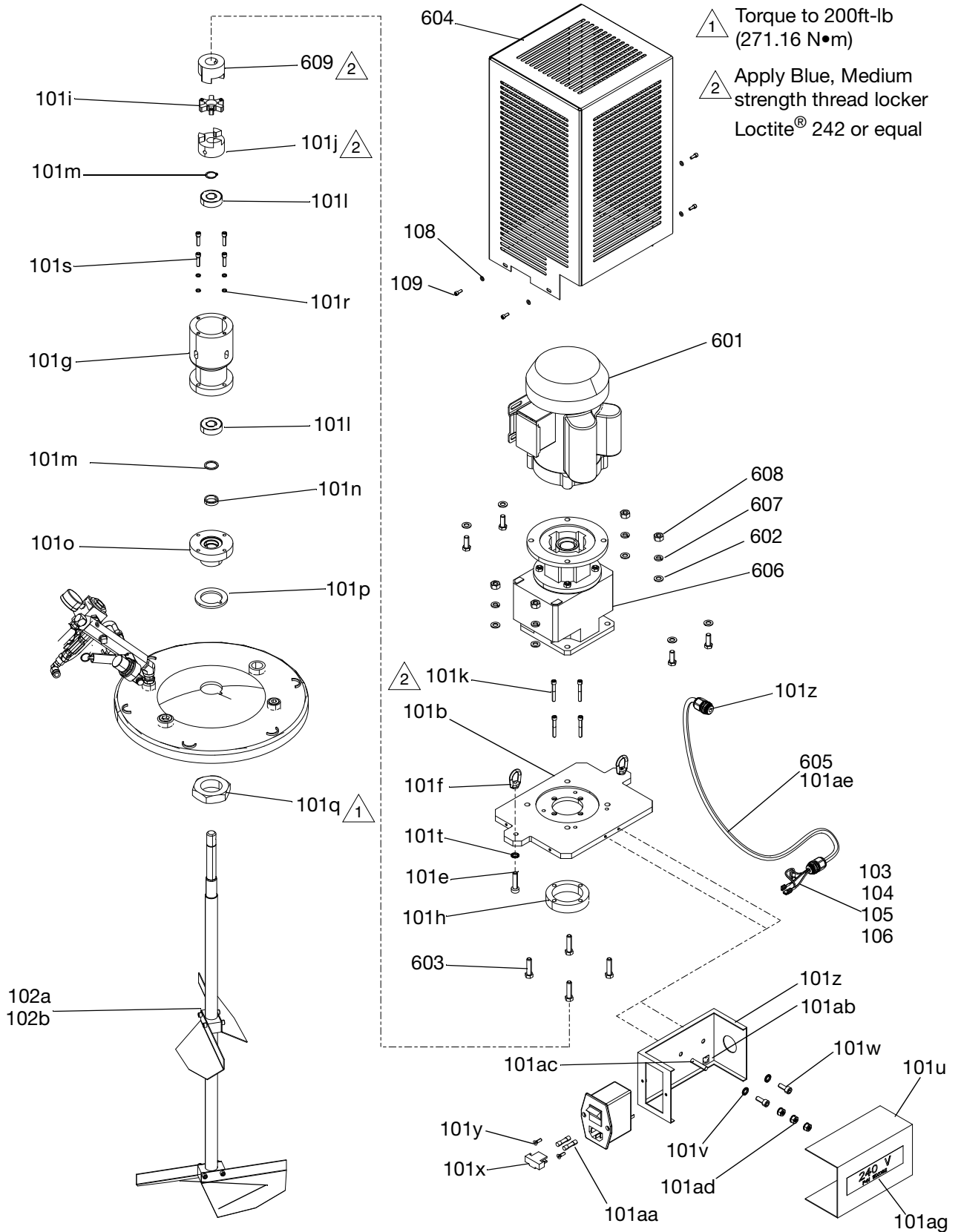

**Lid with agitator for 38L and 75L tanks**

Ref.	Part	Description	Qty.	Ref.	Part	Description	Qty.
101b	---	ADAPTER, plate, agitator motor	1	109	102598	SCREW, cap	4
101e	100021	SCREW, cap	2	601	133444	MOTOR, agitator	1
101f	122775	NUT, eye, 1/4-20	2	602	111203	WASHER	8
101g	15Y358	HOUSING, upper, agitator	1	603	100003	SCREW, hex	4
101h	15V746	SPACER, agitator	1	604	26B890	COVER, motor	1
101i	122760	COUPLING, alignment	1	605	18D338	HARNESS, power	1
101j	122761	COUPLER, hub	1	606	133445	GEARBOX, inline	1
101k	101885	SCREW, cap	4	607	100133	WASHER, lock	4
101l	122774	BEARING, ball	2	608	100131	NUT, hex	4
101m	15Y360	SPACER, seal, shaft	1	609	121963	COUPLER, motor.	1
101n	122772	SEAL	1				
101o	15Y357	HOUSING, lower	1				
101p	15Y363	GASKET	1				
101q	15Y355	NUT, shaft	1				
101r	105510	WASHER, lock	4				
101s	112222	SCREW, cap	4				
101t	100985	WASHER, lock	2				
101u	15R328	JUNCTION BOX, motor switch	1				
101v	111307	WASHER, lock	2				
101w	102598	SCREW, cap	2				
101x	120910	SOCKET, electrical	1				
101y	120916	SCREW	2				
101z	121172	GRIP, cord	2				
101aa	115142	FUSE, 5.0 amp, time lag	2				
101ab	125008	LABEL, earth ground	1				
101ac	121013	SCREW, socket head	1				
101ad	120993	NUT, hex	3				
101ae	24H375	HARNESS, ground	1				
101ag	15X092	LABEL, 240 volts	1				
102a*	257608	BLADE, assy 75L	1				
102b*	257607	BLADE, assy, 38L	1				
102c*	257604	BLADE, assy,38L/75L	See Table				
102d*	15M625	SHAFT, blade assy 75L	See Table				
102e*	15M624	SHAFT, blade assy 38L	See Table				
103	122776	TERMINAL, ring	1				
104	124436	CAP, splice	3				
105	124437	CONNECTOR, splice	3				
106	124442	TERMINAL, ring	1				
108	116876	WASHER	4				

▲ Replacement Danger and Warning labels, tags, and cards are available at no cost.

**\* Blade Assembly Table**

Blade Assembly Ref No.	Qty. Reference No. 102c	Qty. Reference No.120d	Qty. Reference No. 102e
<b>102A</b>	<b>2</b>	<b>1</b>	<b>-</b>
<b>102B</b>	<b>2</b>	<b>-</b>	<b>1</b>

## Lid Assembly

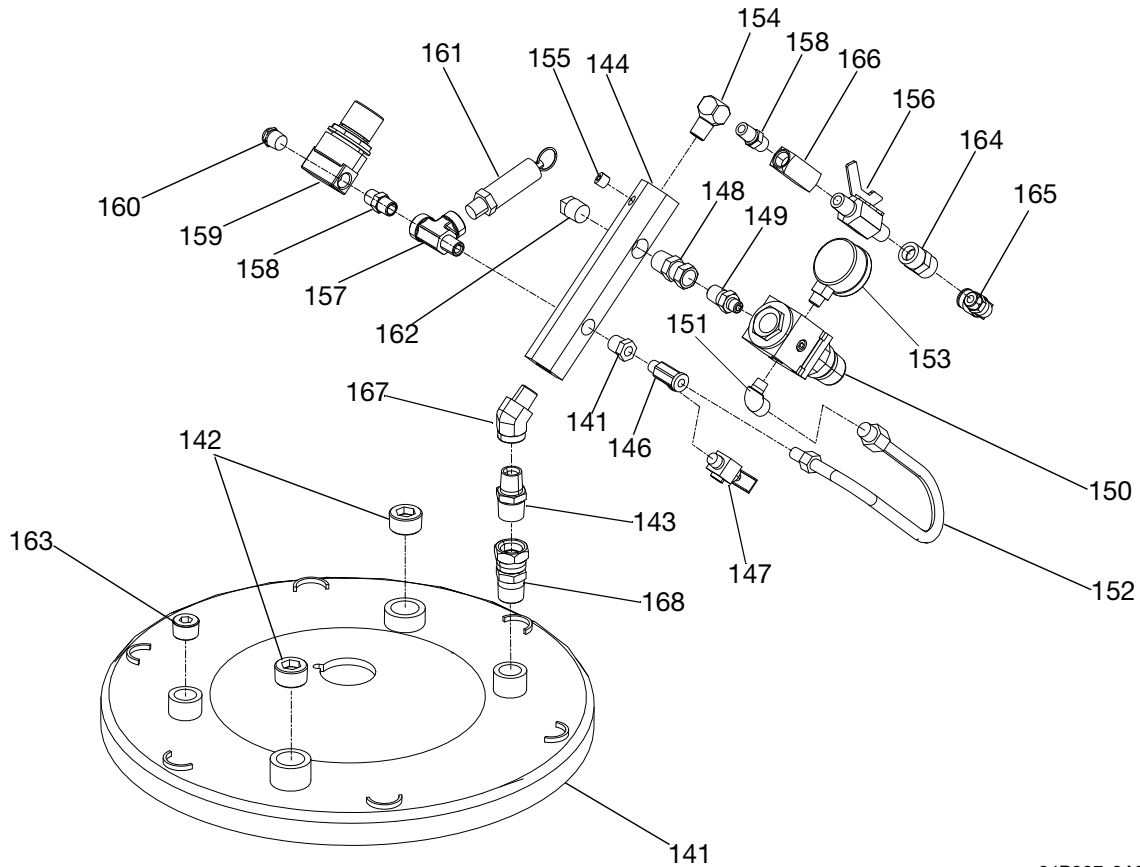

r\_24B967\_3A0395a\_1a

## Lid Assembly Parts List

Ref. Part	Description	Qty.	Ref. Part	Description	Qty.
141	---	1	141	LID, agitator	1
142	125009	2	142	PLUG, pipe	2
143	159239	1	143	NIPPLE, pipe	1
144	189016	1	144	MANIFOLD, air, inlet	1
145	100030	1	145	BUSHING	1
146	110475	1	146	FITTING, street, tee	1
147	101759	1	147	FITTING, drain	1
148	110476	1	148	ADAPTER, union, straight swivel	1
149	151519	1	149	NIPPLE, reducing	1
150	110341	1	150	REGULATOR, air	1
151	112307	1	151	ELBOW, street	1
152	164724	1	152	HOSE, coupled	1
153	111598	1	153	GAUGE, pressure, air	1
154	100840	1	154	ELBOW, street	1
155	100139	1	155	PLUG, pipe	1
156	208390	1	156	VALVE, ball	1
157	123256	1	157	FITTING, tee; 1/4 npt	1
158	123257	2	158	NIPPLE, hex; 1/4 npt	2
159	123258	1	159	VALVE, bleed; 1/4 npt	1
160	121021	1	160	MUFFLER; 1/4 npt	1
161	103347	1	161	VALVE, safety; 100 psi	1
162	104813	1	162	PLUG, pipe	1
163	100361	1	163	PLUG, pipe	1
164	121089	1	164	COUPLING; 1/4 npt, f-f	1
165	121018	1	165	ELBOW, male, swivel; 1/4 npt	1
166	125848	1	166	VALVE, check, 1/4npt	1
167	867185	1	167	45 deg. elbow	1
168	156684	1	168	SWIVEL, union	1

*NOTE: To order complete air valve assembly use part No. 24H244.*

### Plug Assembly for Lid

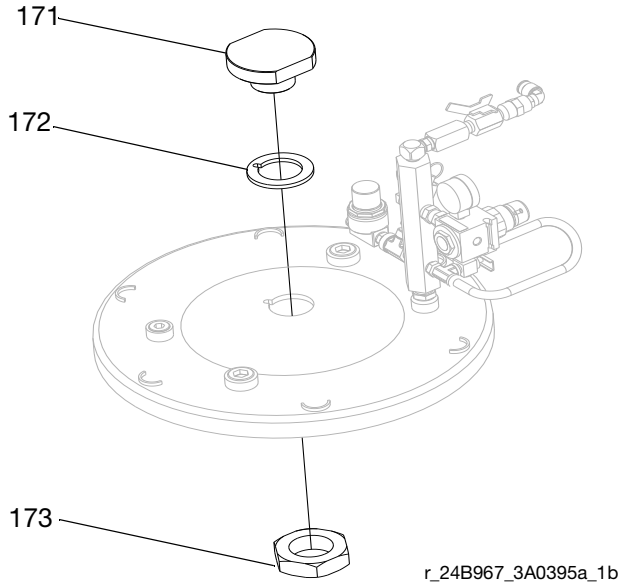

Ref. Part	Description	Qty
171	16A354 PLUG	1
172	15Y363 GASKET, mounting	1
173	15Y355 NUT	1

### Vacuum Degas Lid Assembly

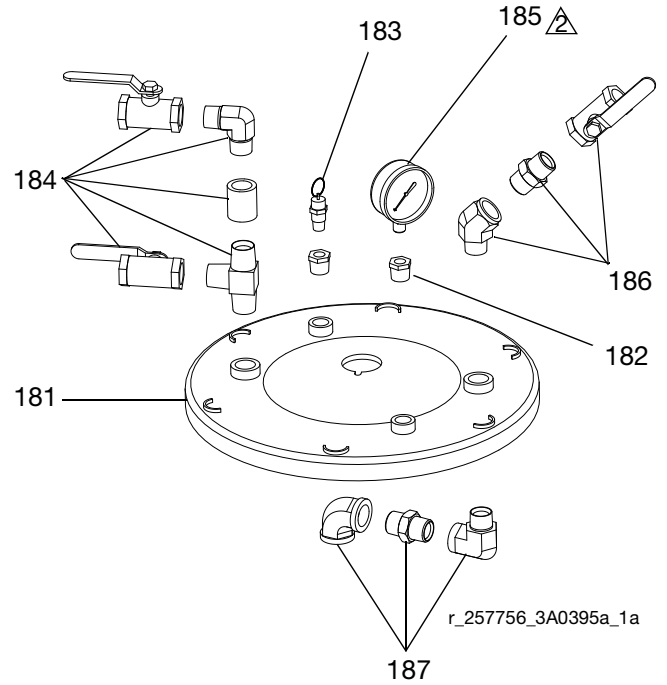

 Apply thread sealant and PTFE thread tape.

Ref.	Part	Description	Qty
181	---	LID, agitator	1
182	122767	BUSHING,; 1/2 x 1/4 npt	2
183	103347	VALVE, safety; 100 psi	1
184	257746	KIT, vacuum tree	1
185	124400	GAUGE, pressure/vac	1
186	257602	VALVE, assy., ball, fill; 3/4 SST	1
187	---	FITTING, assy., inner fill port	1

# Electrical Panel 230V for Heat

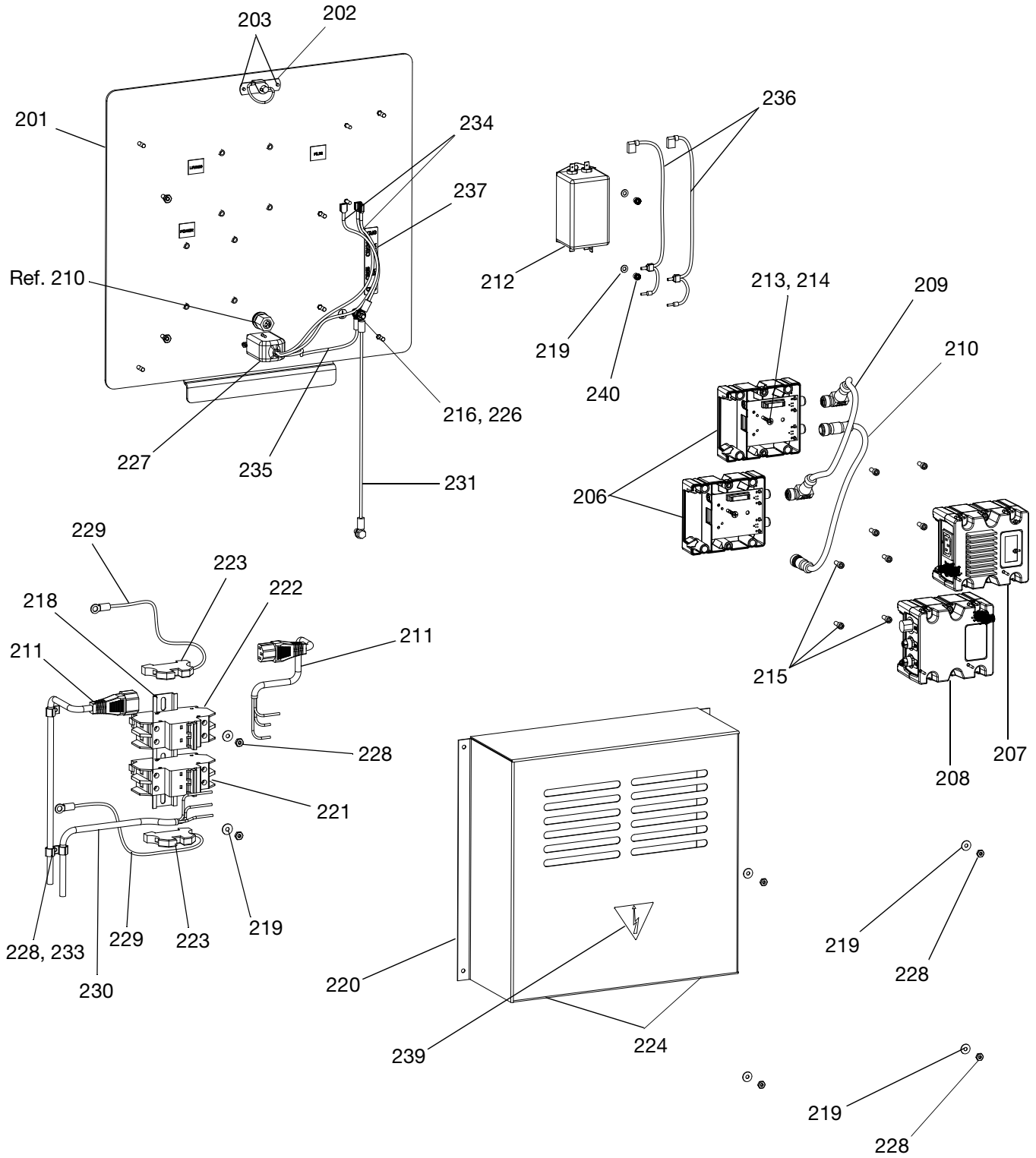

r\_24C169\_3A0395Aa\_1b

# Electrical Panel 230V for No Heat

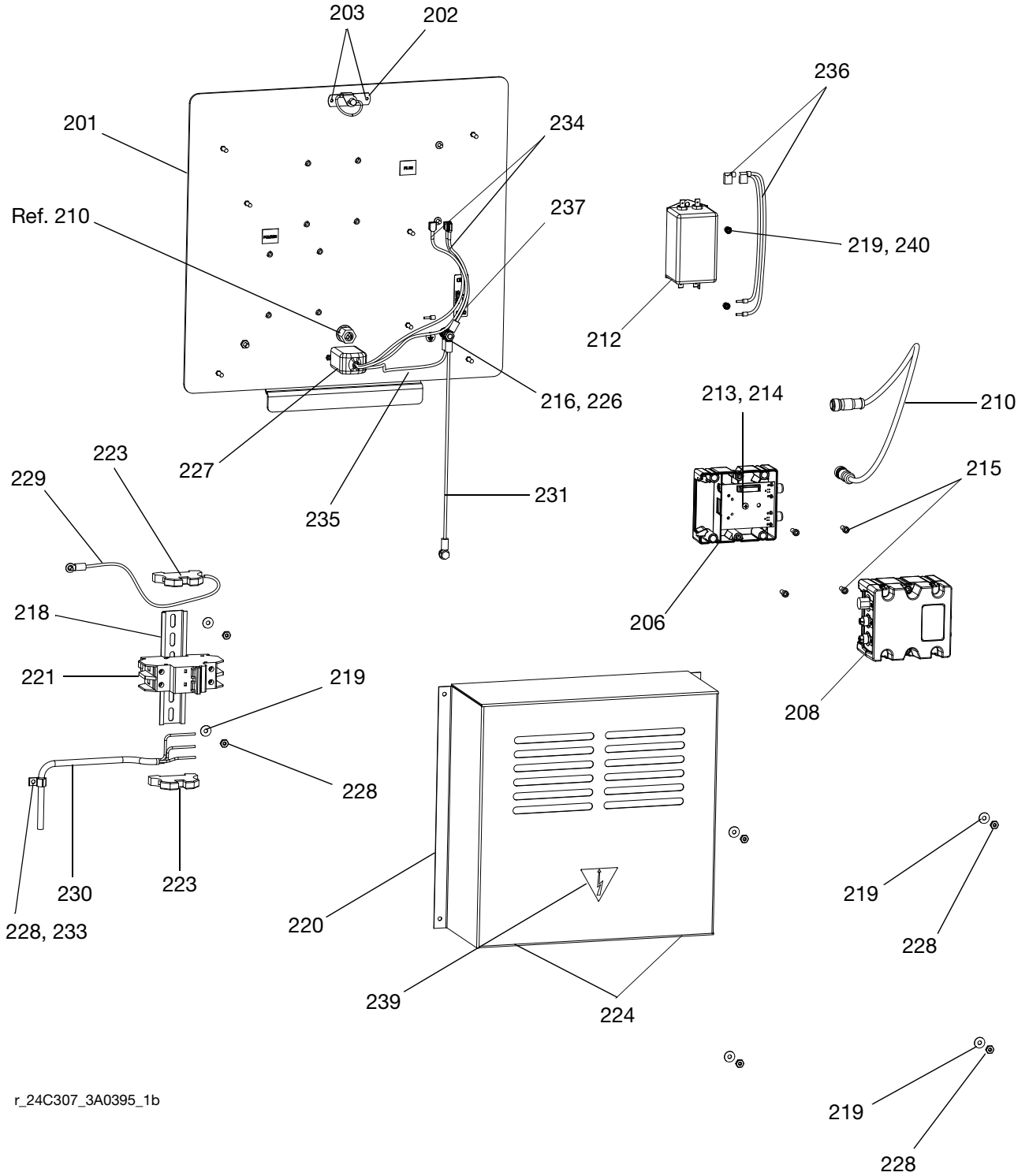

r\_24C307\_3A0395\_1b

**Electrical Panel, 230V for Heat Parts**  
**Electrical Panel, 230V for No Heat Parts**

Ref.	Part	Description	Qty	Ref.	Part	Description	Qty
201	-----	COVER, enclosure	1	230	24D748	HARNESS, power, cube	1
202	117644	LATCH, spring, slotted	1	231	24D847	HARNESS, ground, tank	1
203	102556	RIVET, blind	2	232	123944	HARNESS, power cord, tank stand; 20A	1
204★	-----	PLUG, inlet, electric	1	233	124338	CLAMP, harness; 3/8 in., nylon	3
205★	102410	SCREW, cap socket head	2	234	24E278	HARNESS, filter, power in	2
206	289697	MODULE, cube, base	2	235	24E277	HARNESS, power in/ground	2
207❖	256270	MODULE, low power temp	1	236	❖24E279	HARNESS, filter/breaker	2
208	289696	MODULE, fluid control	1		†24E346	HARNESS, filter/breaker, single	
209❖	121597	CABLE, CAN 90 female / 90 female, 0.4 meter	1	237	-----	LABEL, identification	1
210	121226	CABLE,CAN, male / female, 0.4m	1	238	24E236	HARNESS, filter/ground	1
211❖	24D747	HARNESS, power, cube, heat/chiller	1	239▲	196548	LABEL, caution	1
212	124064	FILTER	1	240	124337	NUT, allen	2
213	114993	SCREW, machine pan head	2	★ <i>Not shown.</i>			
214	102063	WASHER, lock, ext	2	▲ <i>Replacement Danger and Warning labels, tags, and cards are available at no cost.</i>			
215	113003	SCREW, cap, socket head	8	❖ <i>Included in electrical panel for heat only.</i>			
216	100015	NUT, hex	2	† <i>Included in electrical panel for no heat only.</i>			
218	-----	RAIL, mounting, din; 35mm, 6 in.	1				
219	112776	WASHER, plain	6				
220	-----	ENCLOSURE	1				
221	123296	CIRCUIT, breaker; 2P, 5A	1				
222❖	123297	CIRCUIT, breaker; 2P, 10A	1				
223	123363	BLOCK, terminal, ground; 10mm	2				
224	123381	TRIM, serrated	12				
225★	121612	CONNECTOR, thru; m12, m x f	1				
226	100985	WASHER, lock ext	3				
227	123351	COVER, inlet	1				
228	100166	NUT, full hex	8				
229	24C292	HARNESS, ground, strap, cube	2				



# Electrical Panel, 230V for 2 Gallon Tanks Only

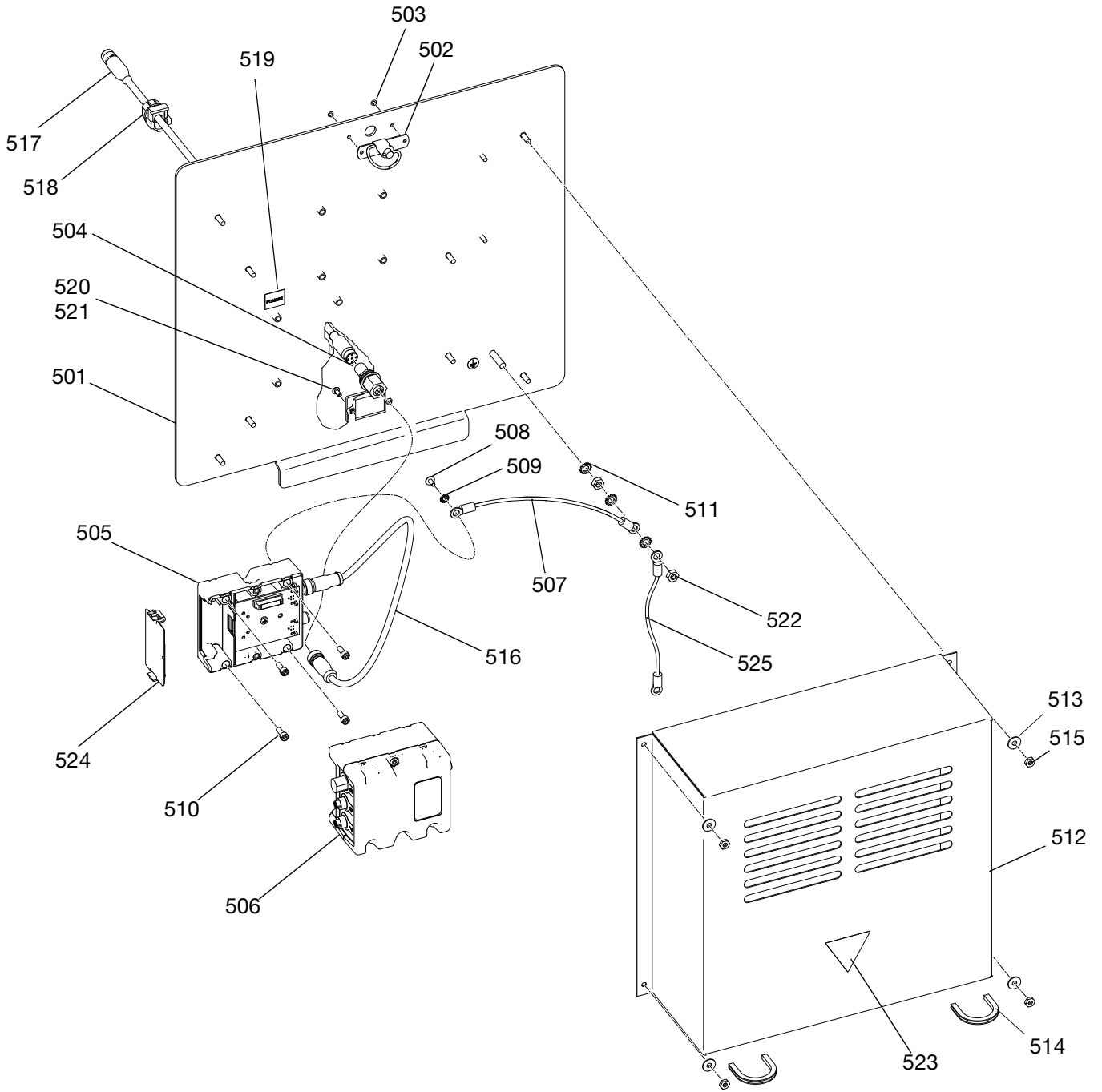

ti7778a

Parts

Ref.	Part	Description	Qty
			-
501	24C116	COVER, enclosure, electrical, tank	1
502	117644	LATCH, spring, slotted	1
503	102556	RIVET, blind	2
504	121612	CONNECTOR, thru, m12, mxm	1
505	289697	MODULE, gca, cube, base	1
506	289696	MODULE, gca, cube, fcm	1
507	24H240	HARNESS, wire, ground, term, 9"	1
508	102063	WASHER, lock, ext	1
509	114993	SCREW, mach, pan wash hd	1
510	102598	SCREW, cap, socket head	4
511	100985	WASHER, lock ext	3
512	24C115	ENCLOSURE, elec, tank stand	1
513	112776	WASHER, plain	4
514	123381	TRIM, serrated	2
515	100166	NUT, full hex	4
516	121226	CABLE, can, male / female, 0.4m	1
517	121000	CABLE, can, female / female 0.5m	1
518	124005	BUSHING, strain relief	1
519▲	16D656	LABEL, identification, electronics	1
520	24H241	COVER, electrical	1
521	15U075	SCREW, cap, bh, 8-32 x .37	2
522	100015	NUT, hex mscr	2
523▲	196548	LABEL, caution	1
524	277674	ENCLOSURE, cube door	1
525	24D847	HARNESS, ground, tank	1

▲ *Replacement Danger and Warning labels, tags, and cards are available at no cost.*

# Heat Exchanger Assembly

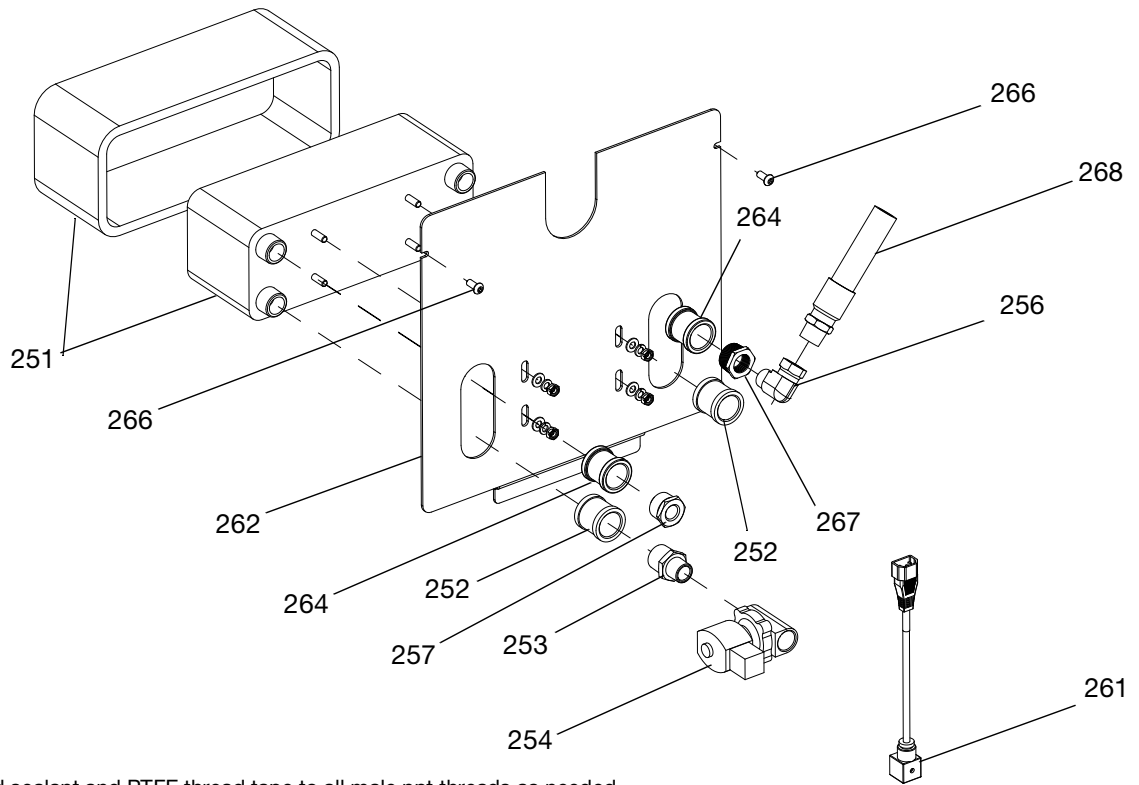

 Apply thread sealant and PTFE thread tape to all male npt threads as needed.

r\_257968\_3A0395Aa\_1a

Ref.	Part	Description	Qty
251	25A210	EXCHANGER	1
252	123071	COUPLING, pipe; 1 in. npt, ff	2
253	123073	NIPPLE, hex; 1 in. npt x 3/4 in. npt	1
254	123028	VALVE, solenoid; 240V	1
256	123998	ELBOW; 3/4 in. npt x 3/4 in. nps, m x f	1
257	513299	BUSHING, reducer	1
261	123093	HARNESS, valve, chiller; 230V	1
262	-----	COVER, enclosure, heat exchange	1
264	123996	COUPLING, 1 in. npt, sst	2
266	111800	SCREW, cap, hex head	2
267	123997	ADAPTER, 1 in. npt x 3/4 in. npt, m x f, sst	1
268	221170	HOSE, coupled; 3 ft	1

# Air Dryer Filter

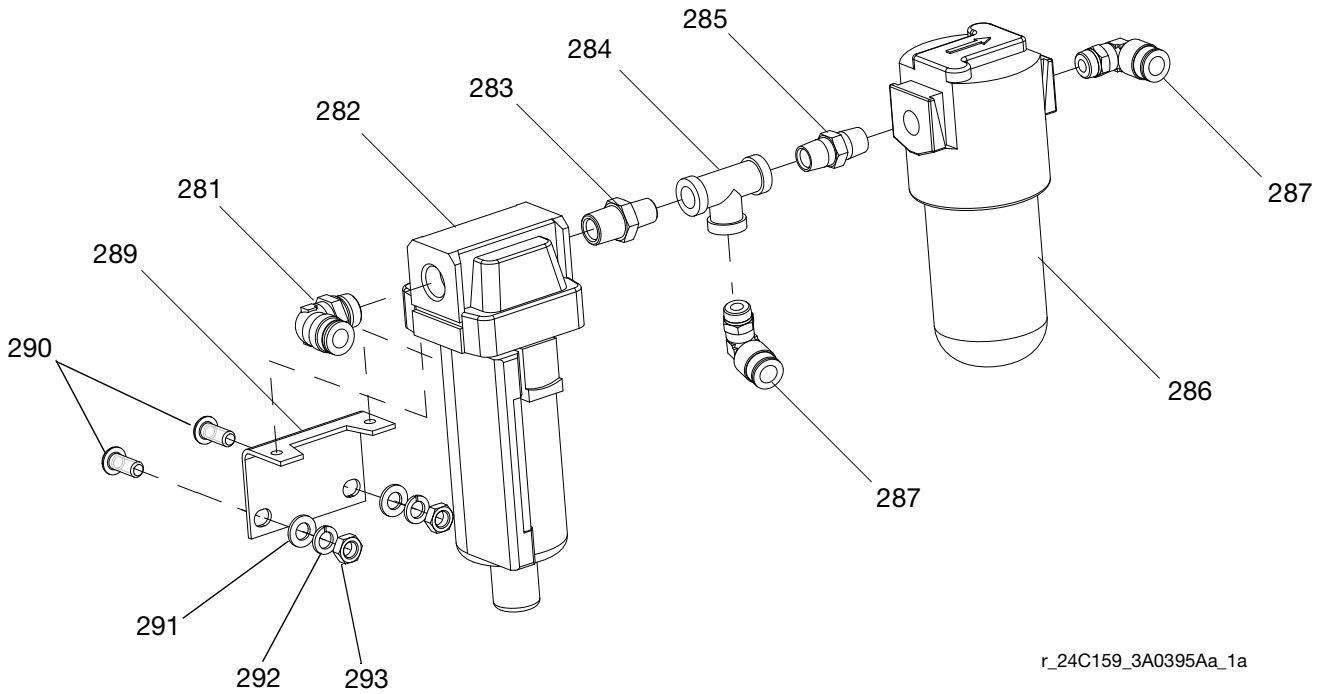

r\_24C159\_3A0395Aa\_1a

Apply thread sealant and PTFE thread tape to all male npt threads as needed.

Ref.	Part	Description	Qty
281	121019	ELBOW, male, swivel; 3/8 npt	1
282	123377	FILTER, air; 3/8 npt	1
283	123379	FITTING, reducer; 3/8 npt x 1/4 npt	1
284	104984	FITTING, tee, pipe	1
285	156971	NIPPLE, short	1
286	-----	DRYER, air, with desiccant; 1/4 npt	1
287	121018	ELBOW, male, swivel; 1/4 npt	2
288	123376	FITTING, tee, run; 1/4 tube x 1/4 npt	1
289	123380	BRACKET, filter, air; 3/8 npt	1
290	112944	SCREW, cap, button head	2
291	107194	WASHER, plain	2
292	100214	WASHER, lock	2
293	111303	NUT, hex	2
295★	054106	TUBE, PET; 0.375 OD	-

★ Not shown.

# Ball Valve Assemblies

**Ball Valve Assembly**

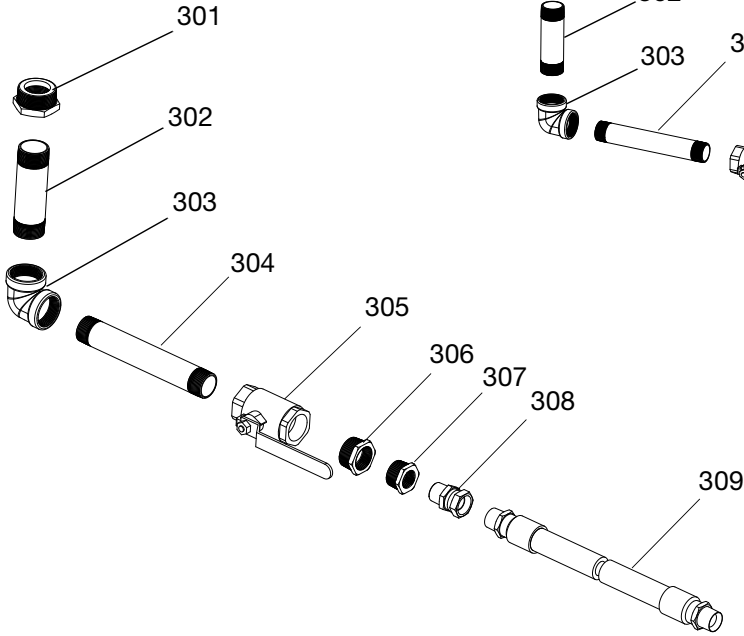

**Ball Valve Assembly with Filter**

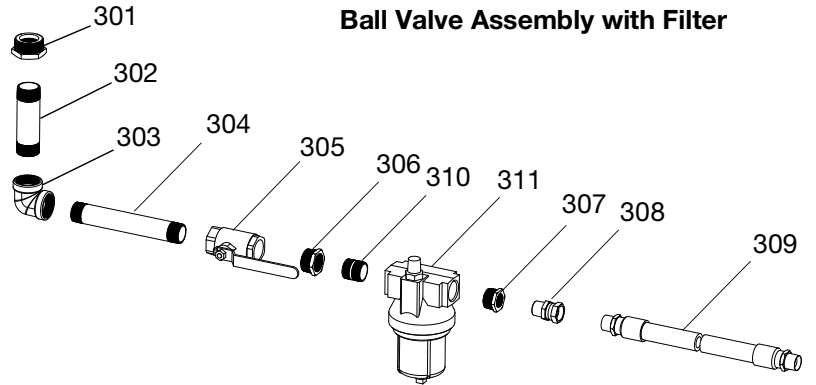

r\_257742\_3A0395Aa\_1a

r\_24E107\_3A0395Aa\_1a

 Apply thread sealant and PTFE thread tape to all male npt threads as needed.

Ref.	Part	Description	Qty
301	121136	BUSHING, hex; 2 in. npt x 1-1/2 in. npt	1
302	123001	NIPPLE; 1-1/2 x 6 in., sst	1
303	123003	ELBOW; 1-1/2 x 1-1/2, f x f, sst	1
304	123000	NIPPLE; 1-1/2 x 10 in., sst	1
305	121135	VALVE, ball; 1-1/2 npt full port	1
306	123002	BUSHING; 1-1/2 npt x 1-1/4 npt	1
307	123348	BUSHING; 1-1/4 npt x 1 npt, mf	1
308	123349	FITTING, union, swivel; 1 npt, mf, sst	1
309	24E024	HOSE, tank to system	1
309	214959	HOSE, coupled, 72L, 1ID, 1NPT, SST (Assembly 24P091 only)	1
310	123346	NIPPLE, close; 1-1/4 npt, sst (with filter version only)	1
311	213062	FILTER, fluid (with filter version only)	1

# Recirculation Probe Assembly

 Apply thread sealant and PTFE thread tape.

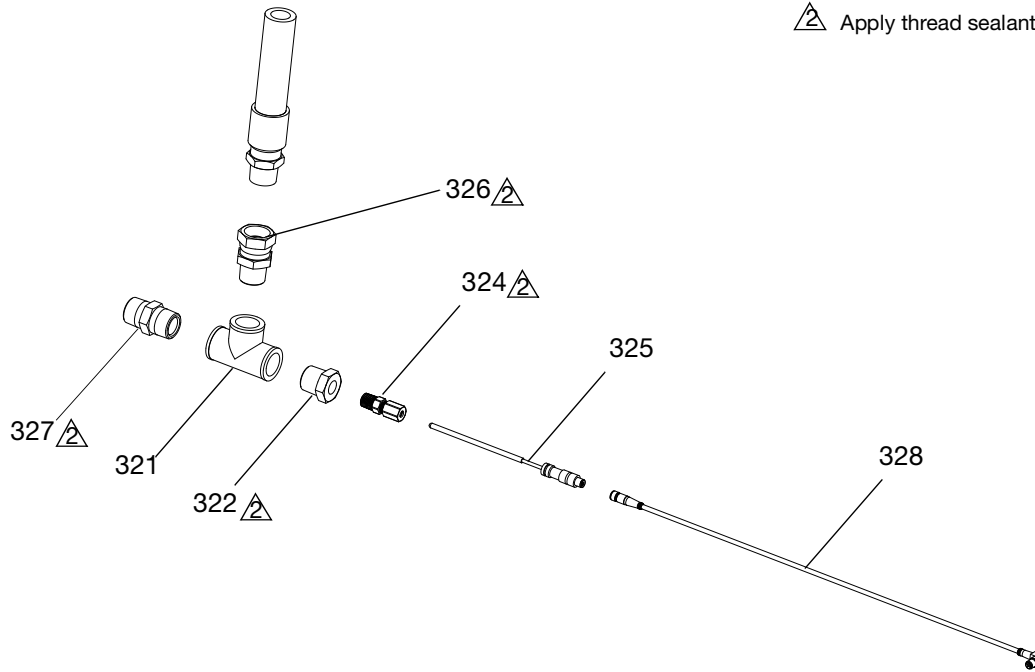

r\_24C156\_3A0395A\_2

Ref.	Part	Description	Qty
321	166466	FITTING, tee, pipe, female	1
322	124280	BUSHING; 3/4 npt x 1/4 npt	1
324	121478	FITTING, compression; 3/16 x 1/4 npt	1
325	124233	SENSOR, RTD, 4 pin; 1kohm, 4.25 in.	1
326	123082	FITTING, swivel; 3/4 nps x 3/4 npt	1
327	119992	FITTING, pipe, nipple; 3/4 x 3/4 npt	1
328	121686	CABLE, CAN; m8 x m8, 4P	1

## Transfer Pump Valve, 24C157

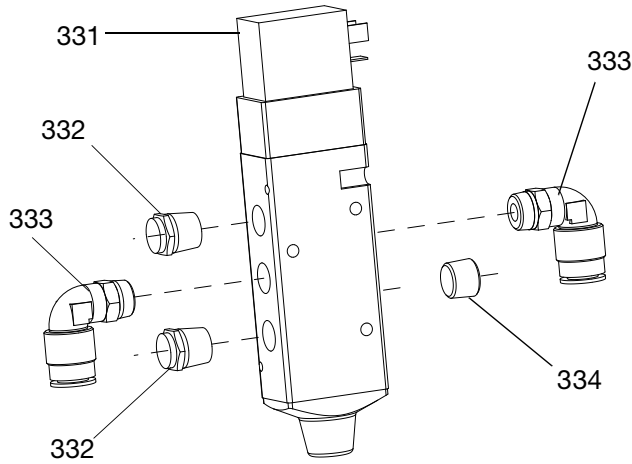

r\_24C157\_3A0395Aa\_1b

Ref.	Part	Description	Qty
331	120900	VALVE, solenoid, 3 way	1
332	121021	MUFFLER; 1/4 npt	2
333	121018	ELBOW, male, swivel; 1/4 npt	2
334	100721	PLUG, pipe	1

# Accessories and Kits

## Level Switch Assembly, 24D271

Third level sensor proximity switch option.

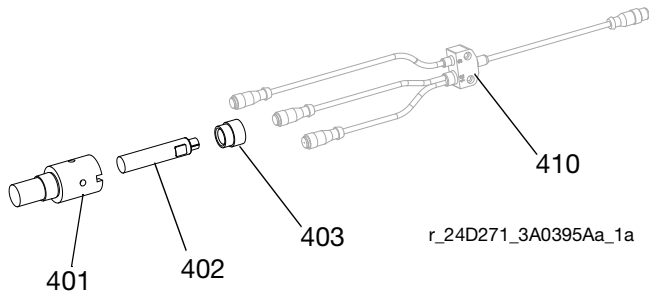

Ref.	Part	Description	Qty
401	16A511	HOUSING, well, proximity	1
402	121511	SENSOR, capacitive, 18 mm	1
403	16A512	NUT, well, proximity	1
410	123394	HARNESS, sensor, level, tank, (3)	Ref

## High Temperature Level Sensor, 24F519 (Circ spray only)

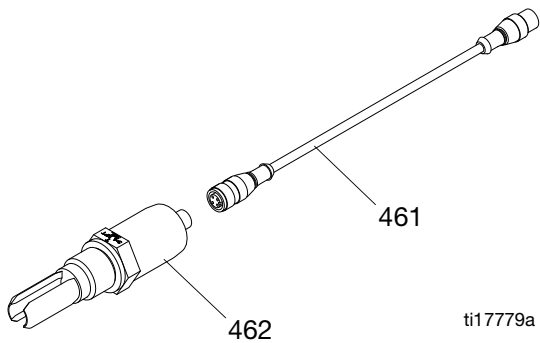

Ref.	Part	Description	Qty
461	125325	HARNESS, M12 x M12	1
462	16H657	SENSOR, level, vibrating	1

## Vacuum Tree Kit, 257746

Connection kit to add vacuum to the tank.

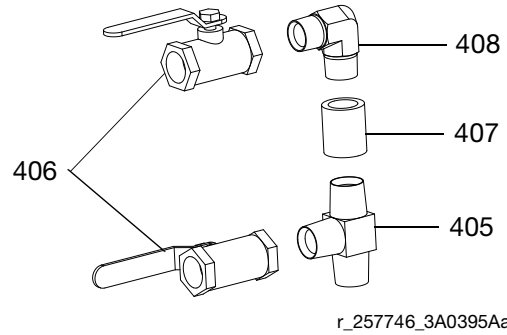

Ref.	Part	Description	Qty
405	122844	FITTING, tee; 3/4 npt(m), 3k, sst	1
406	122770	VALVE, ball; 3/4 npt(f), 2k, sst	2
407	122769	COUPLING, full; 3/4 npt, sst	1
408	121116	ELBOW; 3/4 npt(m)	1



### Supplied Feed Refill Kit, 257770

Refill kit for customer-supplied feed systems.

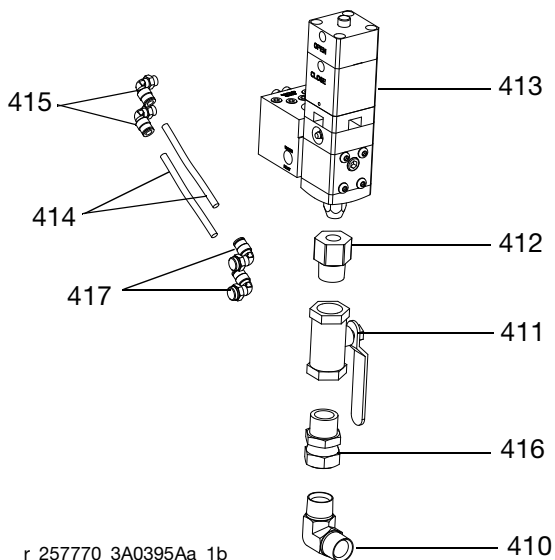

r\_257770\_3A0395Aa\_1b

Ref.	Part	Description
410	121116	ELBOW; 3/4 npt(m)
411	122770	VALVE, ball; 3/4 npt(f), 2k, sst
412	15T005	ADAPTER; 5/8-18 to 3/4 npt, sst
413	244910	VALVE, endure
414	054130	TUBE, PET; 0.25 OD, 12 ft.
415	112698	ELBOW, swivel, male
416	112268	SWIVEL, union
417	121022	ELBOW; 1/4 npt(m)

### High Flow Supplied Feed Refill Kit, 24P673

Refill kit for customer-supplied feed systems.

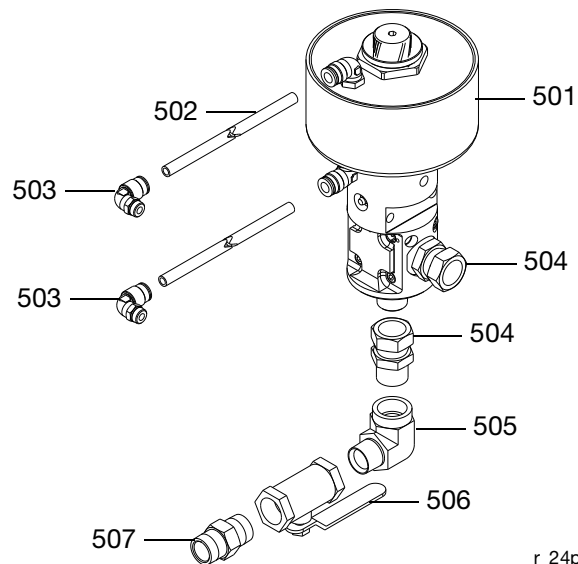

r\_24p673

Qty	Ref.	Part	Description	Qty
-	501	V1M350	VALVE, ball, 3/4"	1
1	502	054106	TUBE, plyeth, .375 OD	-
1	503	121018	FITTING, elbow, male, swivel, 1/4 NPT	2
1	504	112268	SWIVEL, union	2
1	505	122763	FITTING, elbow, str, 3/4 NPT, 90, 3K, sst	1
1	506	122770	VALVE, ball, 2way, 3/4 NPT, female, 2k, sst	1
1	507	123111	FITTING, nipple, hex, 3/4 NPT, 3k, sst	1

### Insulator Blanket Assembly, 257757

For use with heated 38 liter tanks.

Part	Description	Qty
		.
15U022	BLANKET, insulation	1
121208▲	LABEL, warning	1
	TAPE	2
	ADHESIVE	1

▲ Replacement Danger and Warning labels, tags, and cards are available at no cost.

### Insulator Blanket Assembly, 257758

For use with heated 75 liter tanks.

Part	Description	Qty
		.
15U023	BLANKET, insulation	1
121208▲	LABEL, warning	1
	TAPE	2
	ADHESIVE	1

▲ Replacement Danger and Warning labels, tags, and cards are available at no cost.

### Agitator with Heat Blanket Kits

The following kits are only for 20 gal (75L) tank stands. For additional information and parts breakdown, refer to **Related Manuals** on page 3.

Part	Description	Qty
		.
24K346	Heat blanket with pneumatic agitator	1
24K347	Heat blanket with electric agitator	1

### Insulator Blankets

Part	Description	Qty
		.
125390	For use with 2 gal (7.5L) tanks	1
125388	For use with 20 gal (75L) tanks	1
125389	For use with 10 ga (38L) tanks	1
125391	2"x2" port cover	1

### Single Nitrogen Harness 257778

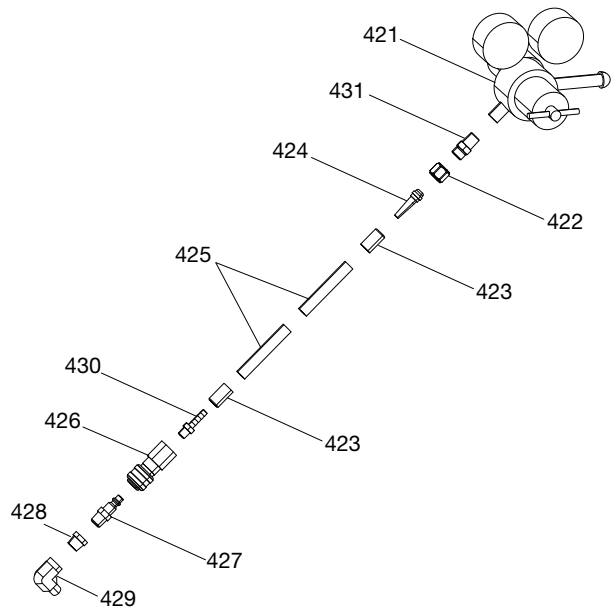

r\_257778\_3A0395Aa\_1a

Ref.	Part	Description	Qty.
421	122647	REGULATOR, nitrogen; 1/4 npt, 1-15 psi	1
422	122649	NUT	1
423	122654	FERRULE	2
424	122773	GLAND, spiral, 1/4 in.	1
425	122758	HOSE, air; 0.25 ID, 0.53 OD, nylon, 10 ft.	-
426	122762	COUPLER; 1/8 npt(f)	1
427	122766	COUPLER; 1/8 npt x 1/4	1
428	122768	BUSHING; 1/4 npt x 1/8 npt	1
429	123249	ELBOW, street, 90 deg.; 1/4 npt	1
430	132834	FITTING, barb, hose, brass	1
431	132837	ADAPTER, threaded	1
432*	079367	SEALANT, thread, PTFE, 20oz.	1

\* Not Shown

### Double Nitrogen Harness 257779

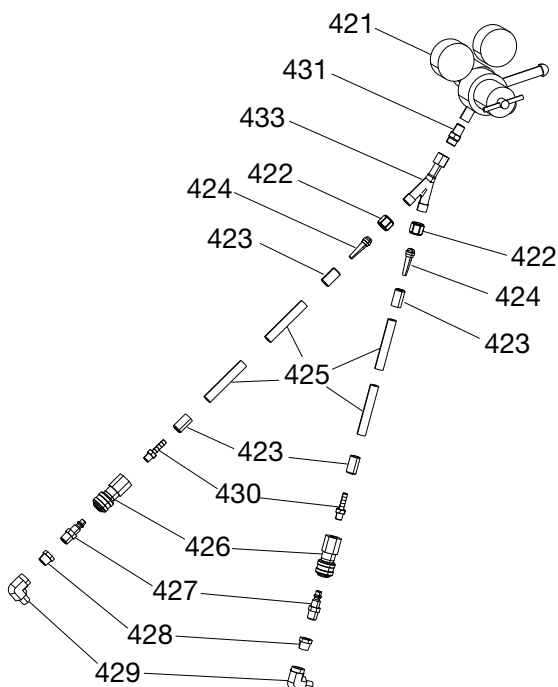

r\_257779\_3A0395Aa\_1a

### Vacuum Pump Assembly, 257916

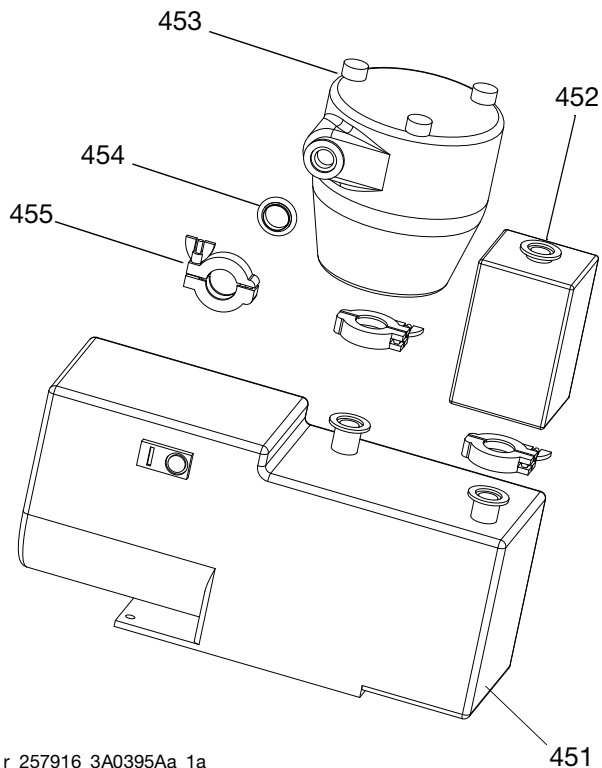

r\_257916\_3A0395Aa\_1a

Ref.	Part	Description	Qty.
421	122647	REGULATOR, nitrogen; 1/4 npt, 1-15 psi	1
422	122649	NUT	2
423	122654	FERRULE	4
424	122773	GLAND, spiral, 1/4 in.	2
425	122758	HOSE, air; 0.25 ID, 0.53 OD, nylon, 20 ft.	-
426	122762	COUPLER; 1/8 npt(f)	2
427	122766	COUPLER; 1/8 npt x 1/4	2
428	122768	BUSHING; 1/4 npt x 1/8 npt	2
429	123249	ELBOW, street, 90 deg.; 1/4 npt	2
430	132834	FITTING, barb, hose, brass	2
431	132837	ADAPTER, threaded	1
432*	079367	SEALANT, thread, PTFE, 20oz.	1
433	122771	CONNECTOR, Y	1

\* Not Shown

Ref.	Part	Description	Qty
451	123029	PUMP, vacuum; 6.9 cfm, 1 ph	1
452	123030	FILTER, mist	1
453	123031	FILTER, trap	1
454	123032	RING	1
455	123033	CLAMP	3

#### Desiccant Dryer Adapter, LC0097

Desiccant dryer (3/8 mpt) with adapter and cartridge.

#### Desiccant Dryer, LC0098

Desiccant dryer refill cartridge.

# Dimensions

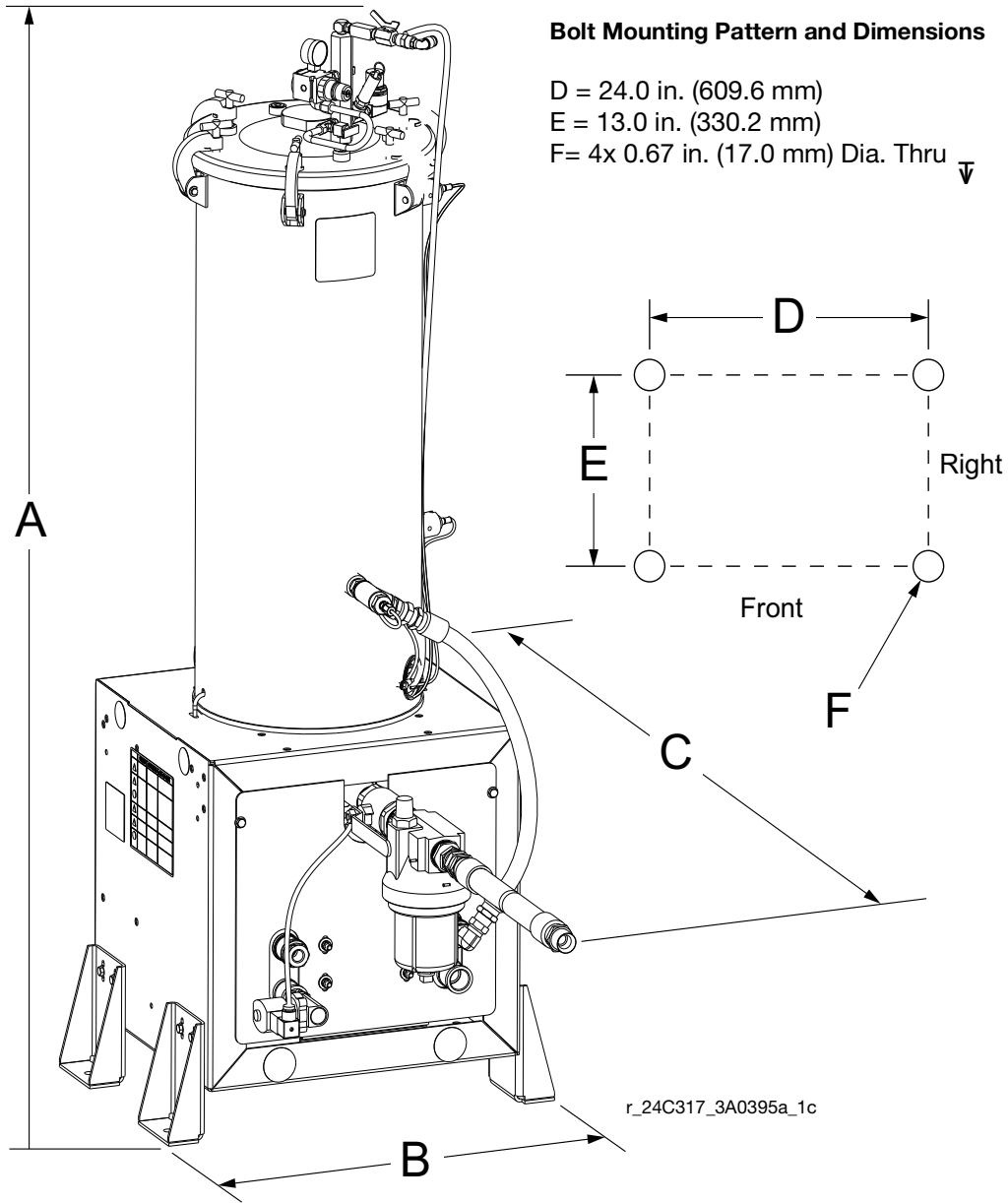

- A = 83.0 in. (2108 mm); 38L/75L tanks with agitation
- A = 69.4 in. (1763 mm); 38L/75L tanks without agitation
- A = 54.0 in. (1372 mm); 7.5L tanks without agitation
- B = 26.0 in. (661 mm)
- C = 34.6 in. (879 mm); depth without hose to system

# Technical Data

Maximum material working pressure	100 psi (0.7 MPa, 7 bar)
Maximum feed supply pressure	100 psi (0.7 MPa, 7 bar)
Maximum air working pressure	100 psi (0.7 MPa, 7 bar)
Maximum fluid working temperature	
with level sensors	150°F (66°C)
without level sensors	190°F (88°C)
Line voltage requirements	230 Vac
Amperage	15 A
Blanket heater power	2400 W
Tank capacity	38 liter (10.0 gallon), 7.5 liter (2.0 gallon)
Maximum weight (empty tank with agitator)	340 lbs (154.4 kg)
Lid without agitator	26.4 lbs (12 kg)
Lid with agitator	135.6 lbs (61.5 kg)
Sound pressure	72.33 dB(A)

## California Proposition 65

### CALIFORNIA RESIDENTS

 **WARNING:** Cancer and reproductive harm – [www.P65warnings.ca.gov](http://www.P65warnings.ca.gov).

# Graco Standard Warranty

Graco warrants all equipment referenced in this document which is manufactured by Graco and bearing its name to be free from defects in material and workmanship on the date of sale to the original purchaser for use. With the exception of any special, extended, or limited warranty published by Graco, Graco will, for a period of twelve months from the date of sale, repair or replace any part of the equipment determined by Graco to be defective. This warranty applies only when the equipment is installed, operated and maintained in accordance with Graco's written recommendations.

This warranty does not cover, and Graco shall not be liable for general wear and tear, or any malfunction, damage or wear caused by faulty installation, misapplication, abrasion, corrosion, inadequate or improper maintenance, negligence, accident, tampering, or substitution of non-Graco component parts. Nor shall Graco be liable for malfunction, damage or wear caused by the incompatibility of Graco equipment with structures, accessories, equipment or materials not supplied by Graco, or the improper design, manufacture, installation, operation or maintenance of structures, accessories, equipment or materials not supplied by Graco.

This warranty is conditioned upon the prepaid return of the equipment claimed to be defective to an authorized Graco distributor for verification of the claimed defect. If the claimed defect is verified, Graco will repair or replace free of charge any defective parts. The equipment will be returned to the original purchaser transportation prepaid. If inspection of the equipment does not disclose any defect in material or workmanship, repairs will be made at a reasonable charge, which charges may include the costs of parts, labor, and transportation.

**THIS WARRANTY IS EXCLUSIVE, AND IS IN LIEU OF ANY OTHER WARRANTIES, EXPRESS OR IMPLIED, INCLUDING BUT NOT LIMITED TO WARRANTY OF MERCHANTABILITY OR WARRANTY OF FITNESS FOR A PARTICULAR PURPOSE.**

Graco's sole obligation and buyer's sole remedy for any breach of warranty shall be as set forth above. The buyer agrees that no other remedy (including, but not limited to, incidental or consequential damages for lost profits, lost sales, injury to person or property, or any other incidental or consequential loss) shall be available. Any action for breach of warranty must be brought within two (2) years of the date of sale.

**GRACO MAKES NO WARRANTY, AND DISCLAIMS ALL IMPLIED WARRANTIES OF MERCHANTABILITY AND FITNESS FOR A PARTICULAR PURPOSE, IN CONNECTION WITH ACCESSORIES, EQUIPMENT, MATERIALS OR COMPONENTS SOLD BUT NOT MANUFACTURED BY GRACO.** These items sold, but not manufactured by Graco (such as electric motors, switches, hose, etc.), are subject to the warranty, if any, of their manufacturer. Graco will provide purchaser with reasonable assistance in making any claim for breach of these warranties.

In no event will Graco be liable for indirect, incidental, special or consequential damages resulting from Graco supplying equipment hereunder, or the furnishing, performance, or use of any products or other goods sold hereto, whether due to a breach of contract, breach of warranty, the negligence of Graco, or otherwise.

## **FOR GRACO CANADA CUSTOMERS**

The Parties acknowledge that they have required that the present document, as well as all documents, notices and legal proceedings entered into, given or instituted pursuant hereto or relating directly or indirectly hereto, be drawn up in English. Les parties reconnaissent avoir convenu que la rédaction du présente document sera en Anglais, ainsi que tous documents, avis et procédures judiciaires exécutés, donnés ou intentés, à la suite de ou en rapport, directement ou indirectement, avec les procédures concernées.

# Graco Information

Sealant and Adhesive Dispensing Equipment

**For the latest information about Graco products, visit [www.graco.com](http://www.graco.com).**

**For patent information, see [www.graco.com/patents](http://www.graco.com/patents).**

**TO PLACE AN ORDER,** contact your Graco distributor, go to [www.graco.com](http://www.graco.com), or call to identify the nearest distributor.

**Toll Free Phone Number:** 1-800-328-2011

*All written and visual data contained in this document reflects the latest product information available at the time of publication. Graco reserves the right to make changes at any time without notice.*

Original instructions. This manual contains English. MM 3A0395

**Graco Headquarters:** Minneapolis

**International Offices:** Belgium, China, Japan, Korea

**GRACO INC. AND SUBSIDIARIES • P.O. BOX 1441 • MINNEAPOLIS MN 55440-1441 • USA**  
**Copyright 2021, Graco Inc. All Graco manufacturing locations are registered to ISO 9001.**

[www.graco.com](http://www.graco.com)  
Revision ZAC, June 2024