

Air-Powered Ram

3A0233L

EN

For transferring or dispensing a non-heated bulk supply of sealants, adhesives, or other medium to high viscosity fluids. Replaces rams for Hydra-Mate™, Precision Dose, 8900 Proportioner, 1:1 Extruders, and robotic interface rams. For professional use only.

Not for use in explosive atmospheres.

D200 3 inch dual post

200 liter (55 gallon)

150 psi (1.0 MPa, 10 bar) Maximum Air Inlet Pressure



Important Safety Instructions

Read all warnings and instructions in this manual.
Save these instructions.

See page 4 for model information and maximum working pressure.

257435 Model Shown

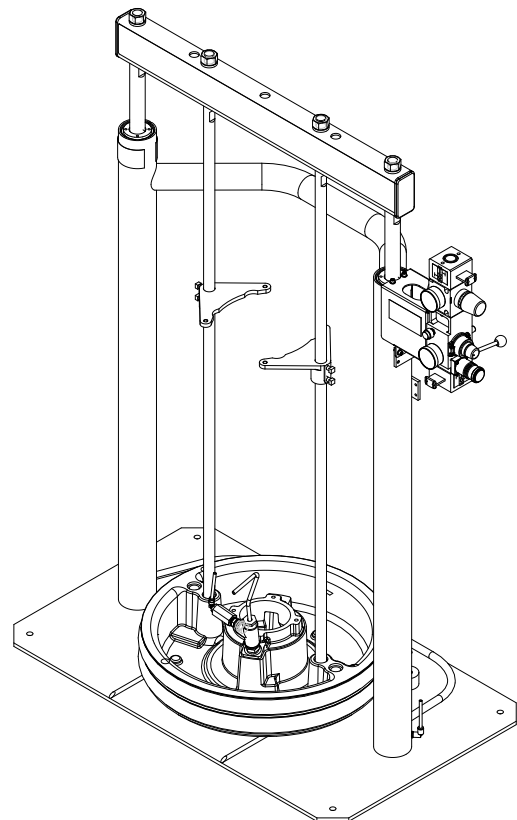

r_257435_3a0233_1c

Table of Contents

Table of Contents	2	Graco Information	26
Related Manuals	3		
Ram Models	4		
Pump Mounting Chart	4		
Warnings	5		
Component Identification	6		
D200 Rams	6		
Integrated Air Controls	7		
Air Line Accessories	7		
Platen Component Identification	7		
Installation	8		
Location	8		
Grounding	8		
Attach Drum Stops	9		
Mount Check-Mate 450, 800, 1000, and 2100 Pumps	10		
Mount Power-Flo, Check-Mate 200, Fire-Ball 300 and Fire-Ball 400 Pumps	11		
3:1 Bulldog Pump	12		
Operation	13		
Pressure Relief Procedure	13		
Flush Before Using Equipment	13		
Start and Adjust Ram	13		
Start and Adjust Pump	14		
Change Drums	14		
Maintenance	15		
Platen Maintenance	15		
Troubleshooting	16		
Repair	17		
Parts	18		
Accessories	22		
200 Liter (55 Gallon) Platen	22		
Drum Position Clamp Set for D200 Ram, 206537 22			
55 Gallon Platen Cover Kit, 255691	22		
Pump Mounting Kit 224829	22		
Platen Mounting Kit 222776	23		
Platen Mounting Kit 247335	23		
Platen Mounting Kit 247336	23		
Platen Mounting Kit 247337	23		
Dimensions	24		
Weight	24		
Technical Data	25		
California Proposition 65	25		
Graco Standard Warranty	26		

Related Manuals

Component Manuals in U.S. English:

Manual	Description
310726	1:1 Extruder, Operation
308930	Hydra-Mate™ Variable Ratio Proportioner
309790	8900 Proportioner
334198	55 gallon, 16 Gallon, and 5 Gallon Ram Module Repair - Parts
307982	Power-Flo® Displacement Pump
307049	Bulldog® Air Motor
309348	King® Air Motor
307043	Monark® Air Motor
312374	Air Controls Instructions-Parts
406681	Platen Cover Kit
3B0243	Drum Stabilizers for D200 and D200s Dual Post Rams

Ram Models

This table lists ram models that replace rams included with Graco bulk supply systems that have older style rams. Ram models without integrated air controls utilize the air controls of the compatible system.

Ram Model	Size	Style	Compatible System	Replaces Ram	Platen	Air Controls
257435	3 in.	D200	Not specified	207279	NA	Integrated air controls with pump regulator
257452	3 in.	D200	Hydra-Mate systems	196079	55 gallon EPDM	NA
257453	3 in.	D200	Hydra-Mate systems	196708	55 gallon neoprene	NA
24C769	3 in.	D200	8900 Proportioner	232110	55 gallon EPDM	Integrated air controls without pump regulator
257461	3 in.	D200	1:1 Extruder	954419	NA	NA

Pump Mounting Chart





This table lists the parts necessary to mount various Graco pumps on the ram. Refer to pages 10-11 for mounting instructions. See **Accessories** on page 22 for parts.

For pump mounting and application information, contact your Graco distributor.

Pump Type	Ram Mounting Kit 224829	Platen Mounting Kit 222776
Monark [®] and President [®] Check-Mate [™] 450 Pumps	✓	✓
Bulldog [®] and Senator [®] Check-Mate [™] 450 Pumps		✓
King [™] , Bulldog [®] , and Senator [®] Check-Mate [™] 800 Pumps		✓
King [™] Check-Mate [™] 1000 Pumps		✓
King [™] , Bulldog [®] , and Viscount [®] Check-Mate [™] 2100 Pumps		✓
King [™] , Bulldog [®] , and Senator [®] Power-Flo [®] Pumps	✓	
Monark [®] and President [®] Check-Mate [™] 200 Pumps	✓	
Bulldog and King Pumps with intake housing mounting flange	✓	
Fire-Ball 300, 50:1	247335 and 247336	
Fire-Ball 425, 10:1, 50:1, 75:1	247335 and 247337	

Warnings

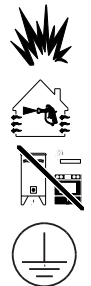
The following warnings are for the setup, use, grounding, maintenance, and repair of this equipment. The exclamation point symbol alerts you to a general warning and the hazard symbol refers to procedure-specific risk. Refer back to these warnings. Additional, product-specific warnings may be found throughout the body of this manual where applicable.

 WARNING	
	<p>SKIN INJECTION HAZARD</p> <p>High-pressure fluid from gun, hose leaks, or ruptured components will pierce skin. This may look like just a cut, but it is a serious injury that can result in amputation. Get immediate surgical treatment.</p> <ul style="list-style-type: none"> • Do not point gun at anyone or at any part of the body. • Do not put your hand over the fluid outlet. • Do not stop or deflect leaks with your hand, body, glove, or rag. • Follow Pressure Relief Procedure in this manual, when you stop dispensing and before cleaning, checking, or servicing equipment. • Tighten all fluid connections before operating the equipment. • Check hoses and couplings daily. Replace worn or damaged parts immediately.
	<p>FIRE AND EXPLOSION HAZARD</p> <p>Flammable fumes, such as solvent and paint fumes, in work area can ignite or explode. To help prevent fire and explosion:</p> <ul style="list-style-type: none"> • Use equipment only in well ventilated area. • Eliminate all ignition sources; such as pilot lights, cigarettes, portable electric lamps, and plastic drop cloths (potential static arc). • Keep work area free of debris, including solvent, rags and gasoline. • Do not plug or unplug power cords, or turn power or light switches on or off when flammable fumes are present. • Ground all equipment in the work area. See Grounding instructions. • Use only grounded hoses. • Hold gun firmly to side of grounded pail when triggering into pail. • If there is static sparking or you feel a shock, stop operation immediately. Do not use equipment until you identify and correct the problem. • Keep a working fire extinguisher in the work area.
	<p>ELECTRIC SHOCK HAZARD</p> <p>This equipment must be grounded. Improper grounding, setup, or usage of the system can cause electric shock.</p> <ul style="list-style-type: none"> • Turn off and disconnect power cord before servicing equipment. • Use only grounded electrical outlets. • Use only 3-wire extension cords. • Ensure ground prongs are intact on power and extension cords. • Do not expose to rain. Store indoors.

Integrated Air Controls

The integrated air controls include:

- **Main air slider valve (AA):** turns air on and off to the system. When closed, the valve relieves pressure downstream.
- **Ram air regulator (AB):** controls ram up and down pressure and blowoff pressure.
- **Ram director valve (AC):** controls ram direction.
- **Exhaust port with muffler (AD)**
- **Air motor regulator (AE):** controls air pressure to motor.
- **Air motor slider valve (AF):** turns air on and off to the air motor. When closed, the valve relieves air trapped between it and the air motor. Push the valve in to shutoff.
- **Blowoff button (AG):** turns air on and off to push the platen out of an empty drum.

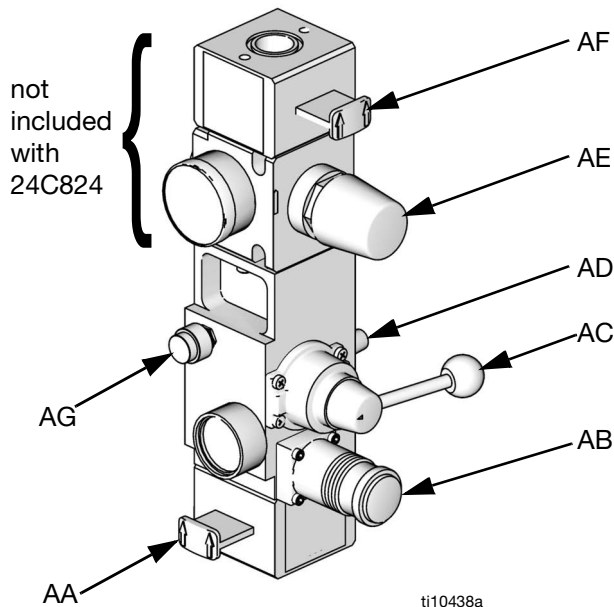

FIG. 2. Integrated Air Controls

Air Line Accessories

See FIG. 1.

- **Air line drain valve (H)**
- **Air line filter (J):** removes harmful dirt and moisture from compressed air supply.
- **Second bleed-type air valve (K):** isolates air line accessories and ram for servicing. Locate upstream from all other air line accessories.
- **Air relief valve** (attached to ram air regulator, not visible): automatically relieves excessive pressure.

Platen Component Identification

255663 and 255664, 200 liter (55 gallon)

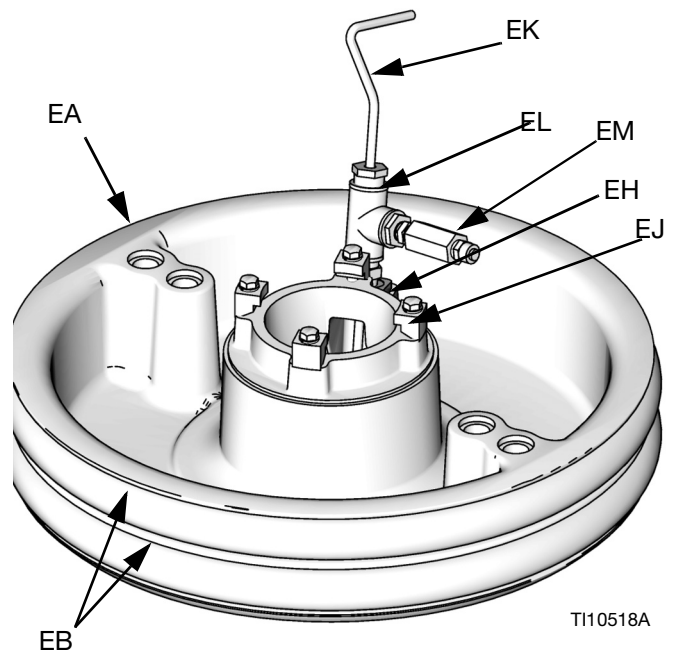

FIG. 3. Platen

Key:

- EA Plate
- EB Wipers
- EG Spacer
- EH Cap Screws
- EJ Clamps
- EK Bleed Handle
- EL Bleed Valve
- EM Air Assist Body Check Valve
- EN Wiper Plate (under wiper)
- EP O-ring Seal

Installation

NOTE: Reference numbers and letters in parentheses in the text refer to the callouts in the figures.

Accessories are available from Graco. Make certain all accessories are adequately sized and pressure-rated to meet the system's requirements.

FIG. 1 is the only guide for selecting and installing system components and accessories. Contact your Graco distributor for assistance in designing a system to suit your particular needs.

Location

NOTICE

Always lift ram at proper lift locations (see FIG. 1). Do **not** lift in any other way. Lifting at these locations allows the ram to be lifted straight up and prevents the ram from bumping into objects nearby.

Attach a lifting sling at the proper lift spots. Lift off the pallet using a crane or a forklift.





Position the ram so the air controls are easily accessible. Ensure that there is enough space overhead for the ram to raise fully. (See **Dimensions**, page 24.)

Using the holes in the ram base as a guide, drill holes for 1/2 in. (13 mm) anchors.

Ensure that the ram base is level in all directions. If necessary, level the base using metal shims. Secure the base to the floor using 1/2 in. (13 mm) anchors that are long enough to prevent the ram from tipping.

Grounding

Trapped air can cause the pump to cycle unexpectedly, which could result in serious injury from splashing or moving parts.

						
<p>The equipment must be grounded. Grounding reduces the risk of static and electric shock by providing an escape wire for the electrical current due to static build up or in the event of a short circuit.</p>						

Pump: use a ground wire and clamp. Loosen grounding lug locknut and washer. Insert one end of supplied ground wire into slot in lug and tighten locknut securely. Connect other end of wire to a true earth ground. See FIG. 4.

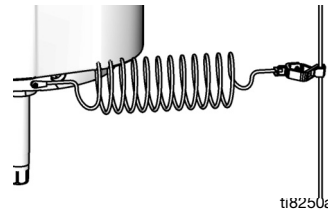

FIG. 4

Air and fluid hoses: use only electrically conductive hoses with a maximum of 500 ft. (150 m) combined hose length to ensure grounding continuity. Check electrical resistance of hoses. If total resistance to ground exceeds 29 megohms, replace hose immediately.

Air compressor: follow manufacturer's recommendations.

Spray gun/dispense valve: ground through connection to a properly grounded fluid hose and pump.

Fluid supply container: follow local code.

Object being sprayed: follow local code.

Solvent pails used when flushing: follow local code. Use only conductive metal pails, placed on a grounded surface. Do not place the pail on a nonconductive surface, such as paper or cardboard, which interrupts grounding continuity.

To maintain grounding continuity when flushing or relieving pressure: hold metal part of the dispense valve firmly to the side of a grounded metal pail, then trigger the valve.

Attach Drum Stops

Rams are shipped with drum stops in place to help position the drum on the ram. For replacement parts, order Kit 255477. The kit includes 2 each of capscrews (FA), lock washers (not shown), and drum stops (FB).

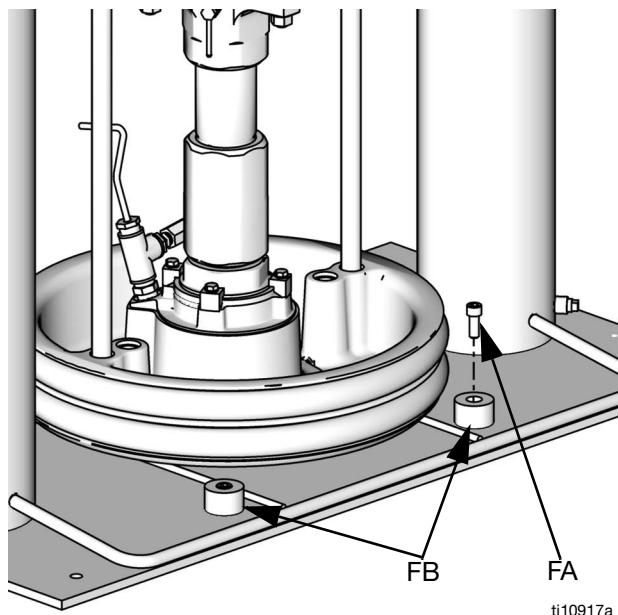

FIG. 5

1. Locate the correct set of mounting holes on the ram base.
2. Using the capscrews (FA) and lock washers (not shown), attach the drum stops (FB) to the ram base.

D200 and D200s Base

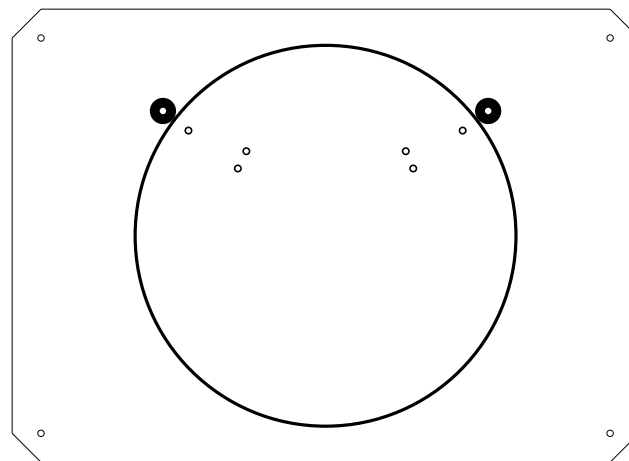

FIG. 6

Attach Drum Stabilizers (optional)

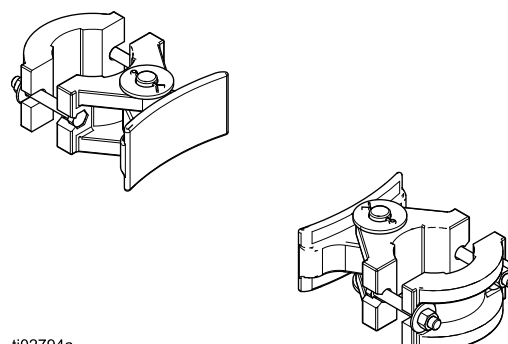

FIG. 7: Kit 206537 For D200 Dual Post Ram

Kits are available for D200 and D200s rams. Install per manual (3B0243) included with kit. Read warnings and instructions included with the kit before operating the system with drum stabilizers installed.

Mount Check-Mate 450, 800, 1000, and 2100 Pumps

NOTE:

The Pump Mounting Chart on page x lists the parts necessary to mount Check-Mate 450, 800, 1000, and 2100 Pumps on this ram. Installing other pumps on the ram may require alternate parts. For information, contact your Graco distributor.

This installation requires Mounting Kit 222776 and 224829 which must be ordered separately. See Accessories on page 22.

1. Position the mounting brackets (42) so that the top of the pump will clear the support beam (4).
2. For President and Monark Check-Mate 450 Pumps *only*, install the mounting plate (CA) from kit 224829 onto the mounting brackets (42) using four screws (CB) and lockwashers (CC). See Fig. 8.

NOTE: The plate (CA) is oriented differently for the President than for the Monark.

For President Pumps

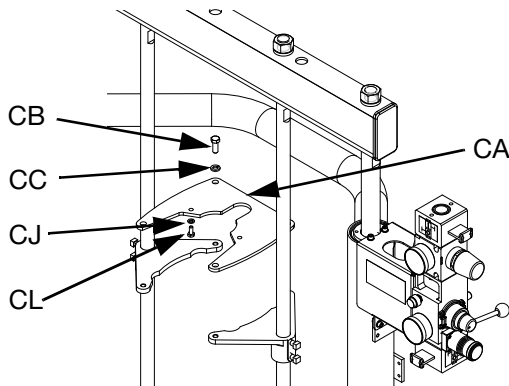

For Monark Pumps

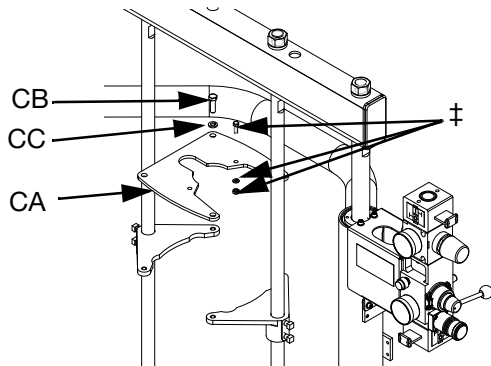

FIG. 8

3. Attach the motor to the mounting brackets (57) or mounting plate (CA) with the fasteners supplied (‡), as applicable.
4. Place the gasket (CK) from Mounting Kit 222776 on the ram plate (114). See FIG. 9. Loosen the mounting bracket setscrews (43), and carefully lower the pump onto the gasket and plate. Secure the pump's intake flange (CN) to the plate with the screws (CL) and lugs (CM) included in the mounting kit.

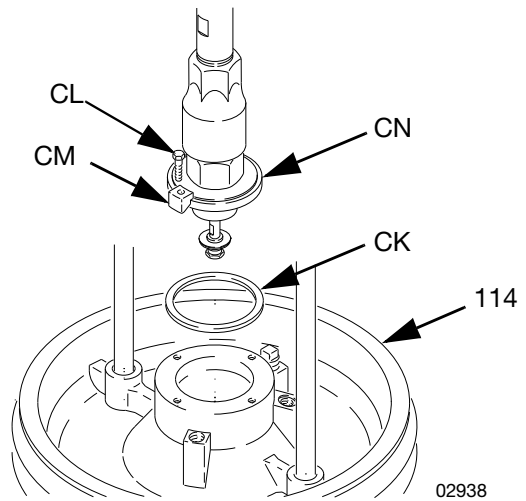

FIG. 9

Mount Power-Flo, Check-Mate 200, Fire-Ball 300 and Fire-Ball 400 Pumps

NOTE:

The Pump Mounting Chart on page 4 lists the parts necessary to mount Power-Flo, Check-Mate 200, Fire-Ball 300 and Fire-Ball 425 pumps on this ram. Installing other pumps on the ram may require alternate parts. For information, contact your Graco distributor.

1. Position the mounting brackets (42) so that the top of the pump will clear the support beam (4).
2. For President, Monark Check-Mate 200, and Fire-Ball Pumps only, install the mounting plate (CA) onto the mounting brackets (42) using four screws (CB) and lockwashers (CC). See FIG. 10.

NOTE: The plate (CA) is oriented differently for the President and Fire-Ball 425 than for the Monark and Fire-Ball 300.

For President and Fire-Ball 425 Pumps

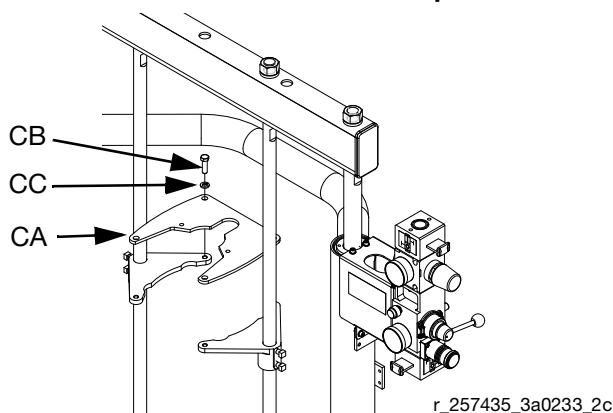

For Monark and Fire-Ball 300 Pumps

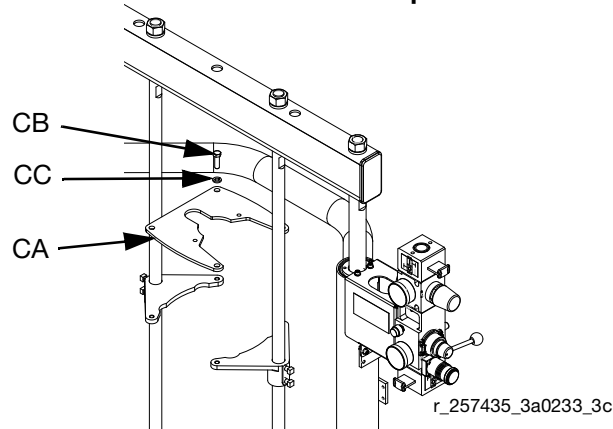

FIG. 10

3. Attach the motor to the mounting brackets (42) or mounting plate (CA) with the fasteners supplied, as applicable.

NOTE: Before proceeding to step 4, install Adapter Kit 224267 for the Fire-Ball 300 pump. Install Adapter Kit 224266 for Fire-Ball 425, 50:1 and 75:1 Pump.

4. Slide the top seal plate (CG) up over the pump intake valve and push the seal (CF) onto the pump intake housing. Leave the bottom seal plate (CG) and gasket (CH) in place. See FIG. 11.
5. Loosen the mounting bracket setscrews (35), and carefully lower the pump until the intake valve is below the gasket (CH), then tighten the setscrews.
6. Push the seal (CF) down firmly against the bottom seal plate (CG).
7. Align the holes in the top seal plate with the holes in the ram plate (114). Secure tightly to the ram plate with the four screws (CD) and washers (CC).

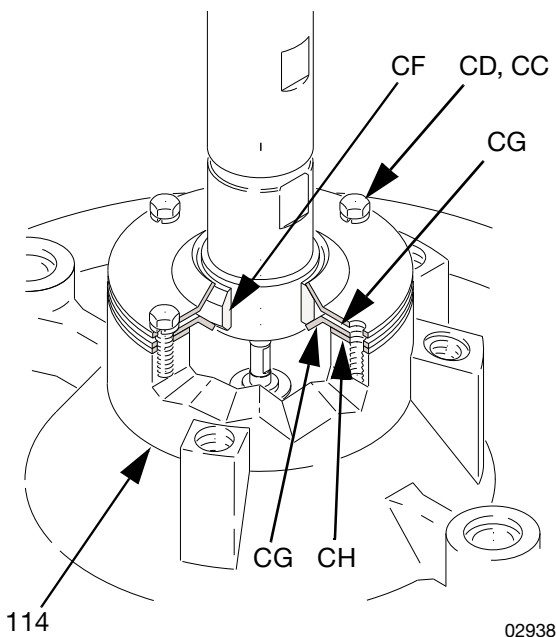

FIG. 11

3:1 Bulldog Pump

1. Remove four nuts (1) from the lower part of the pump as shown in FIG. 12.

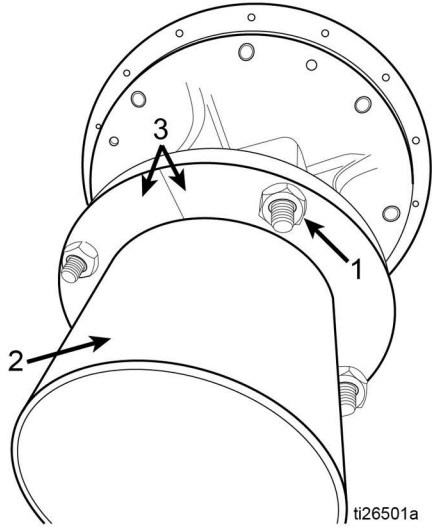

FIG. 12

2. Slide gasket (Part No. 162788) over pump intake cylinder (2). Align holes with cylinder mounting collars (3) and pump (FIG. 12).
3. Lower pump onto platen and align so the bolts from the pump can be attached to the platen (FIG. 13).

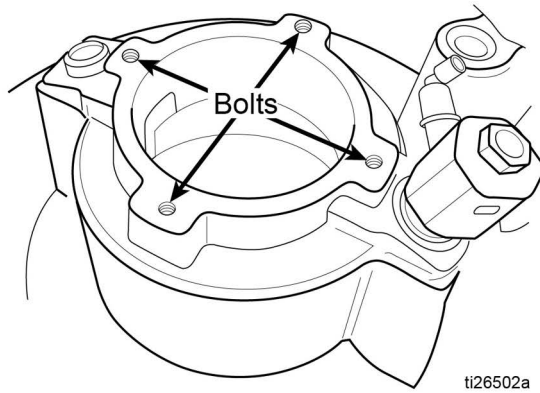

FIG. 13

4. Tight bolts to secure pump.

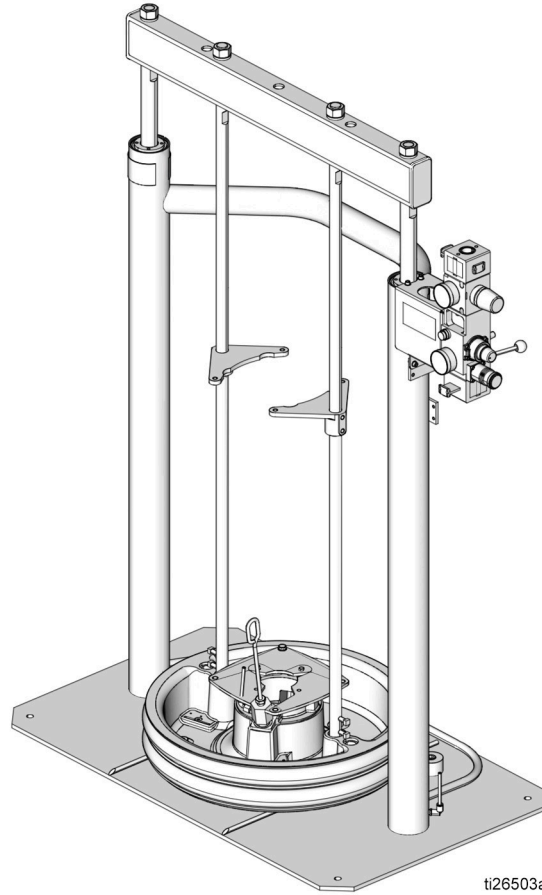
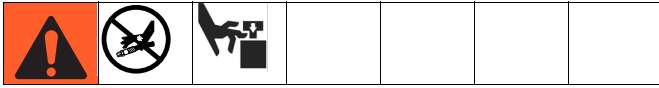

FIG. 14: Model 257435 shown

Operation



Pressure Relief Procedure

1. Lock the gun/valve trigger.
2. **For D200 Air Controls:** See FIG. 2, page 7.
 - a. Close the air motor slider valve (AF) and the main air slider valve (AA).

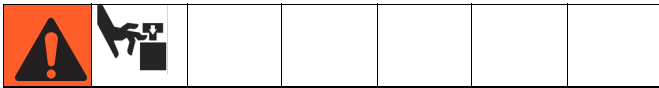

Drum Stabilizers (optional) can interfere with raising or lowering the ram resulting in injury and/or equipment damage. Read drum stabilizer manual 3B0243 before operating your ram if any of these devices are installed.

- b. Set the ram director valve (AC) to DOWN. The ram will slowly drop.
 - c. Jog the director valve up and down to bleed air from ram cylinders.
3. Unlock the gun/valve trigger.
4. Hold a metal part of the gun/valve firmly to the side of a grounded metal pail, and trigger the gun/valve to relieve pressure.
5. Lock the gun/valve trigger.
6. Open the fluid line drain valve and the pump bleeder valve (P). Have a container ready to catch the drainage.
7. Leave the pump bleeder valve (P) open until ready to spray again.

If you suspect that the spray tip/nozzle or hose is completely clogged, or that pressure has not been fully relieved after following the steps above, very slowly loosen the tip guard retaining nut or hose end coupling and relieve pressure gradually, then loosen completely. Now clear the tip/nozzle or hose.

Flush Before Using Equipment

The pump was tested with lightweight oil, which is left in the fluid passages to protect parts. To avoid contaminating fluid with oil, flush the pump with a compatible solvent before use. See pump manual for flushing directions.

Start and Adjust Ram

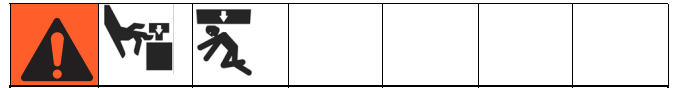

Moving parts can pinch or amputate fingers. When the pump is operating and when raising or lowering the ram, keep fingers and hands away from the pump intake, platen, and lip of the drum.

1. Refer to FIG. 1. Close all air regulators and air valves.
2. Open main air slider valve (AA) and set ram air regulator (AB) to 40 psi (0.28 MPa, 2.8 bar). Set director valve handle (AC) to UP and let the ram rise to its full height. See FIG. 2 on page 7.
3. Lubricate the platen seals (B) with grease or other lubricant compatible with the fluid you will pump.
4. Remove the drum cover and smooth the surface of the fluid with a straightedge.
5. Put a full drum of fluid on the ram base, slide it back against the drum stops, and center it under the platen (B). An optional drum roller kit is available for D200 and D200s rams to make it easier to load the drum on the base. Order Kit 255627.

NOTICE

To avoid damage to the platen seals, do not use a drum that is dented or damaged.

6. Remove bleed stick from platen bleed port (D).
7. If drum has a plastic liner, pull it over edge of drum. Secure liner with tape wrapped around circumference of drum.

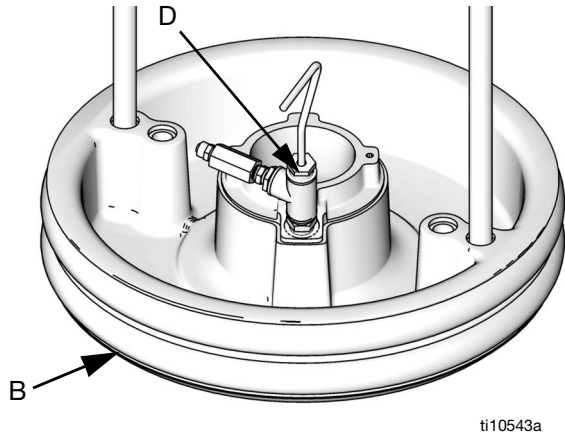

FIG. 15

8. Set the director valve (AC) to DOWN and lower the ram until fluid appears at the top of the platen bleed port (D). Adjust ram air regulator (AB) as needed. Set the director valve (AC) to neutral and close the platen bleed port (D). **2-Button Interlock:** If system has this feature, press and hold both buttons to start lowering the ram. See FIG. 2, page 7.

Start and Adjust Pump

1. Connect pump outlet fittings and hose (not supplied).

NOTE: Be sure all components are adequately sized and pressure rated to meet the system's requirements.

2. Be sure the pump air valve is closed. Then set the ram air regulator (AB) to about 50 psi (0.35 MPa, 3.5 bar). Set the director valve (AC) to DOWN. Start the pump as explained in the separate pump instruction manual.
3. Keep the director valve (AC) set to DOWN while pump is operating.

NOTE: Increase air pressure to the ram if the pump does not prime properly with heavier fluids. Decrease air pressure if fluid is forced out around the top seal or platen.

Change Drums



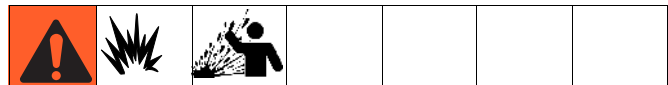

1. Stop the pump.
 - a. Push in the air motor slider valve (AF) to stop the pump.
2. Raise the platen out of the drum.
 - a. Set ram director valve (AC) to UP to raise the platen (B) and immediately press and hold the blowoff air button (AG) until the platen (B) is completely out of drum. Use minimum amount of air pressure necessary to push the platen out of the drum.
3. Follow steps 4-8.



Excessive air pressure in the material drum could cause the drum to rupture, causing serious injury. The platen must be free to move out of the drum. Never use drum blowoff air with a damaged drum.

4. Release the blowoff air button and allow the ram to rise to its full height.
5. Remove empty drum.
6. Inspect platen and, if necessary, remove any remaining material or material build-up.
7. Place full drum on ram base.
8. Lower the ram and adjust the position of the drum relative to the platen. See **Start and Adjust Ram** on page 13.

Maintenance

							
<p>To reduce the risk of serious injury whenever you are instructed to relieve pressure, always follow the Pressure Relief procedure.</p>							

Platen Maintenance

See FIG. 16. If the platen does not come out of the pail easily when the pump is being raised, the air assist tube (F), or check valve may be plugged. A plugged valve prevents air from reaching the underside of the plate to assist in raising it from the pail.

1. Relieve pressure. Refer to parts illustration on page 22 and disassemble air assist valve as shown.
2. Clear air assist tube (F) in platen. Clean all parts of valve and reassemble.
3. Remove bleed stick (EK) from platen. Push bleed stick through bleed relieve ports to remove material residue.

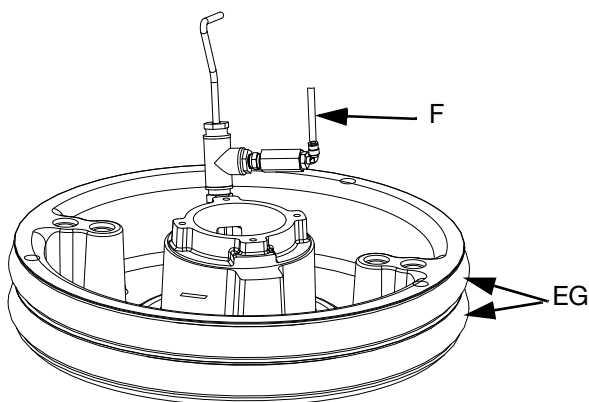

r_255319_3a0233_1b

FIG. 16

Remove 55 Gallon Platen Wipers

1. To replace worn or damaged wipers (EB), raise platen up out of drum. Remove drum from base. Wipe fluid off of platen.
2. Cut top and bottom wipers with knife and remove from platen. See FIG. 17.

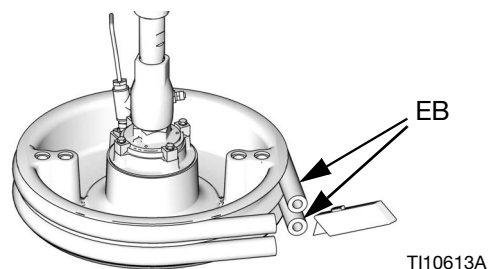

FIG. 17

Reinstall 55 Gallon Platen Wipers

1. Using a wooden or plastic tool to prevent damage to the wiper (EB), clean all material from seal grooves.
2. *Working from the bottom*, angle one wiper (EB) over back of platen. See FIG. 18.
3. Insert wiper (EB) in top groove and run front of wiper into groove.
4. Insert second wiper (EB) in lower groove and run front of wiper into groove.
5. Lubricate outside of wiper with lubricant compatible with material being pumped. Check with material supplier.

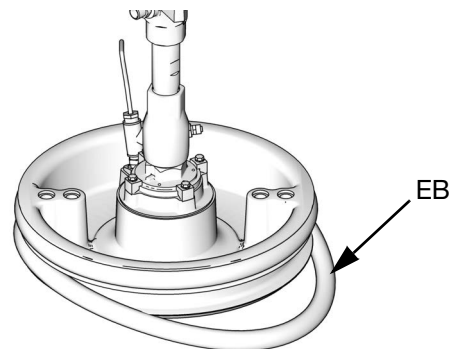





FIG. 18

Troubleshooting

Problem	Cause	Solution
Ram will not raise or lower.	Closed air valve or clogged air line.	Open, clear.
	Not enough air pressure.	Increase.
	Worn or damaged piston.	Replace. See Repair on page 17.
	Hand valve closed or clogged.	Open, clear.
Ram raises and lowers too fast.	Air pressure is too high.	Decrease.
Air leaks around cylinder rod.	Worn rod seal.	Replace. See Repair on page 17.
Fluid squeezes past ram plate wipers.	Air pressure too high.	Decrease.
	Worn or damaged wipers.	Replace. See Remove 55 Gallon Platen Wipers on page 15.
Pump will not prime properly or pumps air.	Closed air valve or clogged air line.	Open, clear.
	Not enough air pressure.	Increase.
	Worn or damaged piston.	Replace. See pump manual.
	Hand valve closed or clogged.	Open, clear. See Platen Maintenance on page 15.
	Hand valve is dirty, worn, or damaged.	Clean, service.
Air assist valve will not hold drum down or push plate up.	Closed air valve or clogged air line.	Open, clear. See Platen Maintenance on page 15.
	Not enough air pressure.	Increase.
	Valve passage clogged.	Clean. See Platen Maintenance on page 15.

Repair

						
<p>To reduce the risk of serious injury whenever you are instructed to relieve pressure, always follow the Pressure Relief procedure. Do not use pressurized air to remove the guide sleeve or the piston.</p>						

NOTE: For repair of the D200 rams see the 55 gallon, 16 Gallon, and 5 Gallon Ram Module Repair - Parts manual 334198, **Related Manuals** page 3.

Parts

- 3 in. Ram with EPDM 55 Gallon Platen, 257452
- 3 in. Ram with Neoprene 55 Gallon Platen, 257453
- 3 in. Ram, 257461

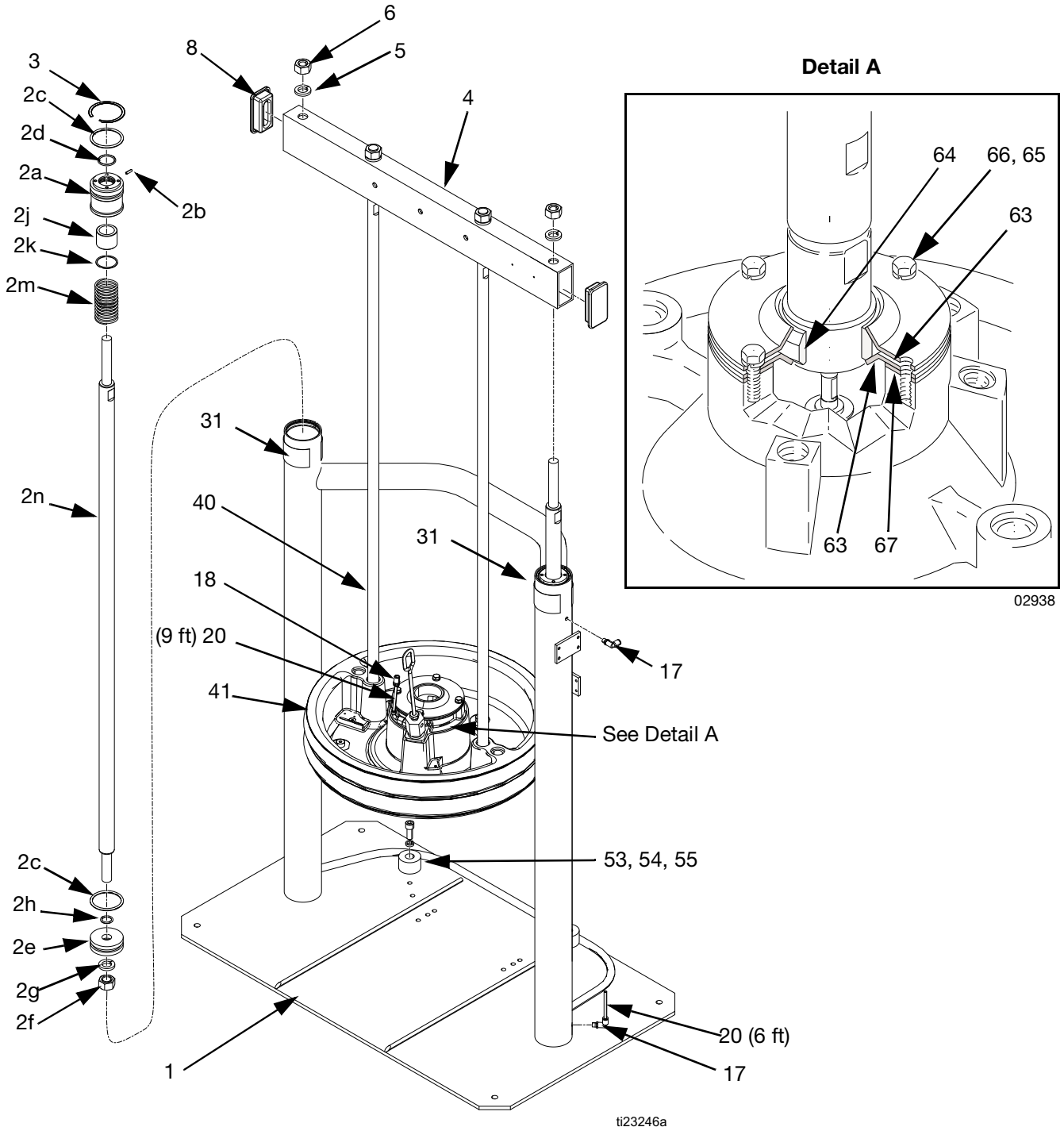

3 in. Ram with EPDM 55 Gallon Platen, 257452
3 in. Ram with Neoprene 55 Gallon Platen, 257453
3 in. Ram, 257461

Ref.	No.	Part No.	Description	Qty
	1‡	255286	RAM, 3 in.	1
	2‡	255328	PISTON, assembly 3 in. ram; includes 2a-2n	2
	2a		BEARING, ram end cap	2
	2b	107092	PIN, spring, straight	2
	2c*		O-RING	4
	2d*		O-RING	2
	2e	183943	PISTON	2
	2f*		NUT, jam	2
	2g*		WASHER, split	2
	2h*		O-RING	2
	2j*		BEARING, ram end cap	2
	2k*		RETAINER, retaining ring	2
	2m*		SPRING, compression	2
	2n	167651	ROD, piston, ram	2
	3*‡	127510	RING, retaining, 3.06 dia	2
	4	621386	BEAM, support	1
	5	101533	WASHER, spring lock	4
	6	101535	NUT, full hex	4
	8	189559	CAP, end	2
	17‡	128863	FITTING, elbow	2
	18	C19407	FITTING, connector, male	1
	20‡	C12509	TUBE, nylon, rnd; 18 ft	1
	31▲	15J074	LABEL, safety	4
	40	167652	ROD, tie ram	2
	41	255663	PLATE, wiper 55gal EPDM; 257452 only	1
		255664	PLATE, wiper 55gal neoprene; 257453 only	1
	53	C19853	SCREW, cap, socket hd	2
	54	C38185	WASHER, lock	2
	55	C32467	STOP, drum	2
	63	162789	PLATE, seal	2
	64	161452	SEAL, follow plate	1
	65	100133	WASHER, lock	4
	66	100004	SCREW, cap, hex hd	4
	67	162788	GASKET	1

▲ Replacement Danger and Warning labels, tags, and cards are available at no cost.

* Parts included in repair kit 255687 (purchase separately).

‡ Parts used with 257461 3 in. ram.

3 in. Ram with Integrated Air Controls, 24C769

3 in. Ram with Integrated Air Controls and 55 Gallon EPDM Platen, 257435 & 25R470

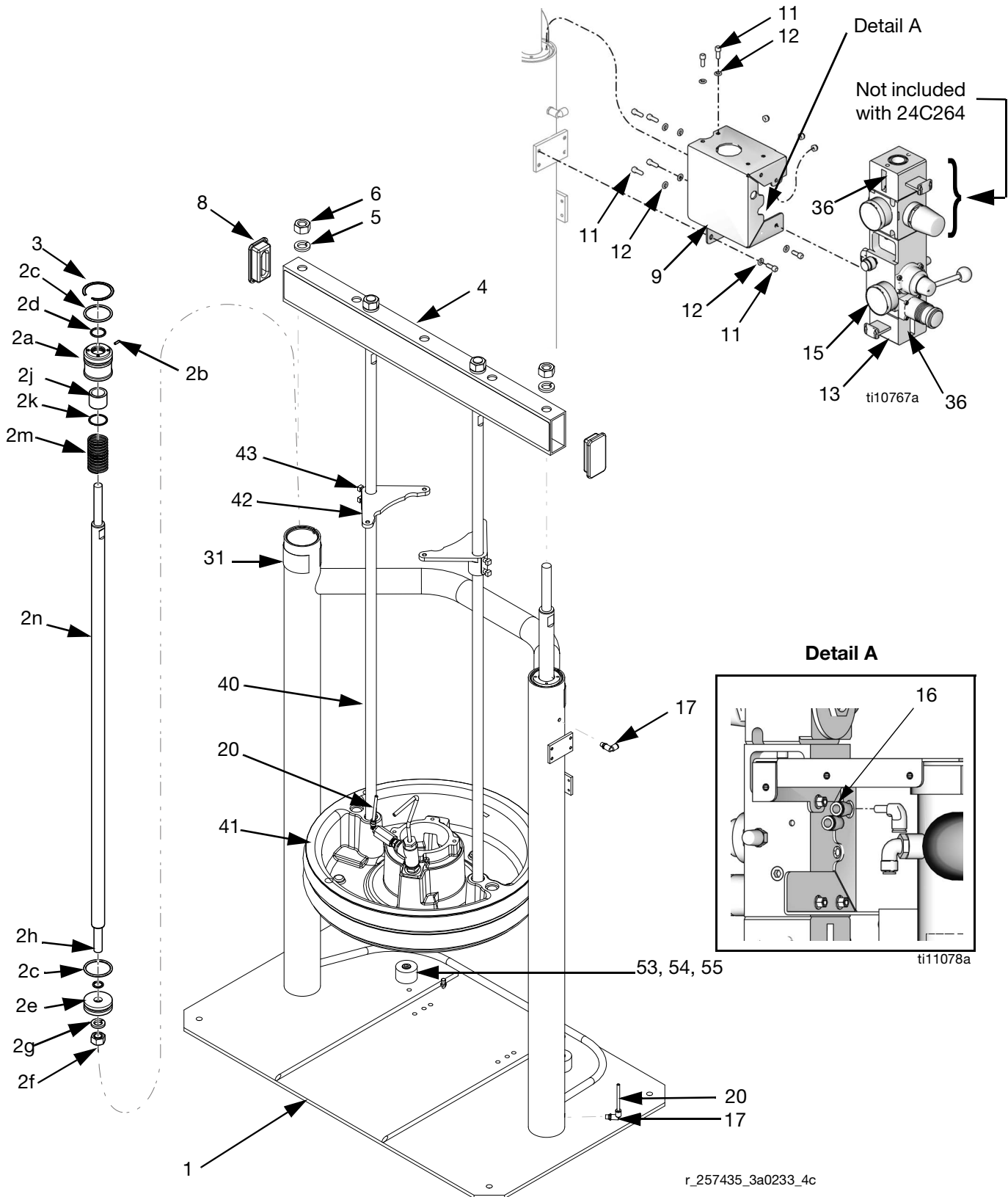

3 in. Ram with Integrated Air Controls, 24C769**3 in. Ram with Integrated Air Controls and 55 Gallon EPDM Platen, 257435 & 25R470**

Ref. No.	Part No.	Description	Qty
1		RAM, 3 in.	1
2	255328	PISTON, assembly 3 in. ram; includes 2a-2n	2
2a		BEARING, ram end cap	2
2b	107092	PIN, spring, straight	2
2c*		O-RING	4
2d*		O-RING	2
2e	183943	PISTON	2
2f*		NUT, jam	2
2g*		WASHER, split	2
2h*		O-RING	2
2j*		BEARING, ram end cap	2
2k*		RETAINER, retaining ring	2
2m*		SPRING, compression	2
2n	167651	ROD, piston, ram	2
3*	127510	RING, retaining, 3.06 dia	2
4	167646	BEAM, tie	1
5	101533	WASHER, spring lock	2
6	101535	NUT, full hex	2
7	15M663	LABEL	1
8	189559	CAP, end	2
9	255296	BRACKET, mounted	1
11	101682	SCREW, cap, sch	8
12	100016	WASHER, lock	8
13	◆ 24C264	CONTROL, air, ram, hyd driver	1
	✿ 289105	CONRTOL, air	1
15	119835	GAUGE, press, air	1
16	132848	FITTING, elbow, plug in	2
17	128863	FITTING, elbow	2
20	C12509	TUBE, nylon, rnd; 15 in.	1
31▲	15J074	LABEL, safety	4
36▲	15V954	LABEL, valve, shutoff, air control	1
40	✿ 167652	ROD, tie ram	2
41	✿ 255663	PLATE, wiper 55 gal EPDM	1
	25R468	PLATE, wiper 55 gal NITRILE	1
42	✿ 161822	PLATE, mounting	2
43	✿ 100672	SCREW, set	4
53	C19853	SCREW, cap, socket hd	2
54	C38185	WASHER, lock	2
55	C32467	STOP, drum	2

▲ Replacement Danger and Warning labels, tags, and cards are available at no cost.

◆ Only used with 24C769.

✿ Only used with 257435.

* Parts included in repair kit 255687 (purchase separately).

Accessories

200 Liter (55 Gallon) Platen

Platen with EPDM Seals, 255663
 Platen with Neoprene Seals, 255664

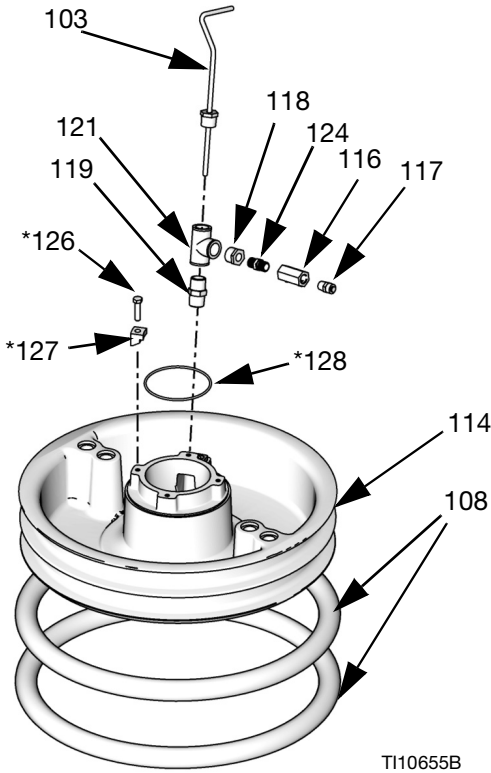

200 Liter (55 Gallon) Platen Parts

Ref. No.	Part No.	Description	Qty
103	255232	HANDLE, bleed assy	1
108	255652	SEAL, wiper, drum, 55 gal., neoprene; for 255664 only.	2
	255653	SEAL, wiper, drum, 55 gal., EPDM; for 255663 only.	2
114		PLATE, ram 55 gal.	1
116	114243	VALVE, check	1
117	114153	FITTING, TUBE, quick disconnect	1
118	100505	BUSHING, pipe	1
119	119992	NIPPLE, 3/4 x 3/4 npt	1
121	166466	TEE, pipe, female	1
124	156849	NIPPLE	1
126*	102637	SCREW, cap	4
127*	276025	CLAMP	4
128*	109495	O-RING	1

*Parts included in 255392 Kit (purchase separately).

Drum Position Clamp Set for D200 Ram, 206537

(Includes two clamps) Attach to ram cylinders to center drum in place and prevent drum from moving.

55 Gallon Platen Cover Kit, 255691

See 406681 for more information.

Pump Mounting Kit 224829

See pages 10 for mounting instructions. Required for mounting President and Monark Check-Mate 450 pumps.

Ref. No.	Part No.	Description	Qty
CA	184140	PLATE, mounting	1
CB	100101	SCREW, hex hd, cap; 3/8-16 x 1 in. (25.4 mm)	4
CC	100133	LOCKWASHER, spring, 3/8 in.	8
CD	100004	SCREW, hex hd, cap; 3/8-16 x 1-1/4 in. (31 mm)	4
CF	161452	SEAL, ram plate, standard	1
CG	162789	PLATE, seal, standard	2
CH	162788	GASKET; cork	1
CJ	100016	WASHER, lock	2
CK	102025	NUT, hex, regular	2
CL	100270	SCREW, cap, hex	2
CM	15B588	SCREW, cap, socket	2

Platen Mounting Kit 222776

See page 10 for mounting instructions. Required for mounting Check-Mate 450, 800, 1000, and 2100 pumps on the ram.

See manual 405952 for parts.

Platen Mounting Kit 247335

See pages 11 for mounting instructions. Required for mounting Fire-Ball 300 and Fire-Ball 425 pumps.

Ref. No.	Part No.	Description	Qty
CC	100133	LOCKWASHER, spring, 3/8 in.	4
CD	100004	SCREW, hex hd, cap; 3/8-16 x 1-1/4 in. (31 mm)	4
CF	160098	SEAL, ram plate	1
CG	162789	PLATE, seal, standard	2
CH	162788	GASKET; cork	1

Platen Mounting Kit 247336

See pages 11 for mounting instructions. Required for mounting Fire-Ball 300, 50:1 pumps.

Ref. No.	Part No.	Description	Qty
CA	184140	PLATE, mounting	1
CB	100101	SCREW, hex hd, cap; 3/8-16 x 1 in. (25.4 mm)	4
CC	100133	LOCKWASHER, spring, 3/8 in.	8
‡	100022	SCREW, hex hd, cap; 1/4-20 x 3/4 in.	2
‡	100016	WASHER, lock	2
‡	100015	NUT, hex, 1/4-20	2

‡ Mounting hardware for pump to plate (CA).

Platen Mounting Kit 247337

See pages 11 for mounting instructions. Required for mounting Fire-Ball 425, 10:1, 50:1, and 75:1 pumps.

Ref. No.	Part No.	Description	Qty
CA	162225	PLATE, mounting	1
CB	100101	SCREW, hex hd, cap; 3/8-16 x 1 in. (25.4 mm)	4
CC	100133	LOCKWASHER, spring, 3/8 in.	8
‡	100022	SCREW, hex hd, cap; 1/4-20 x 3/4 in.	2
‡	100016	WASHER, lock	2

‡ Mounting hardware for pump to plate (CA).

Dimensions

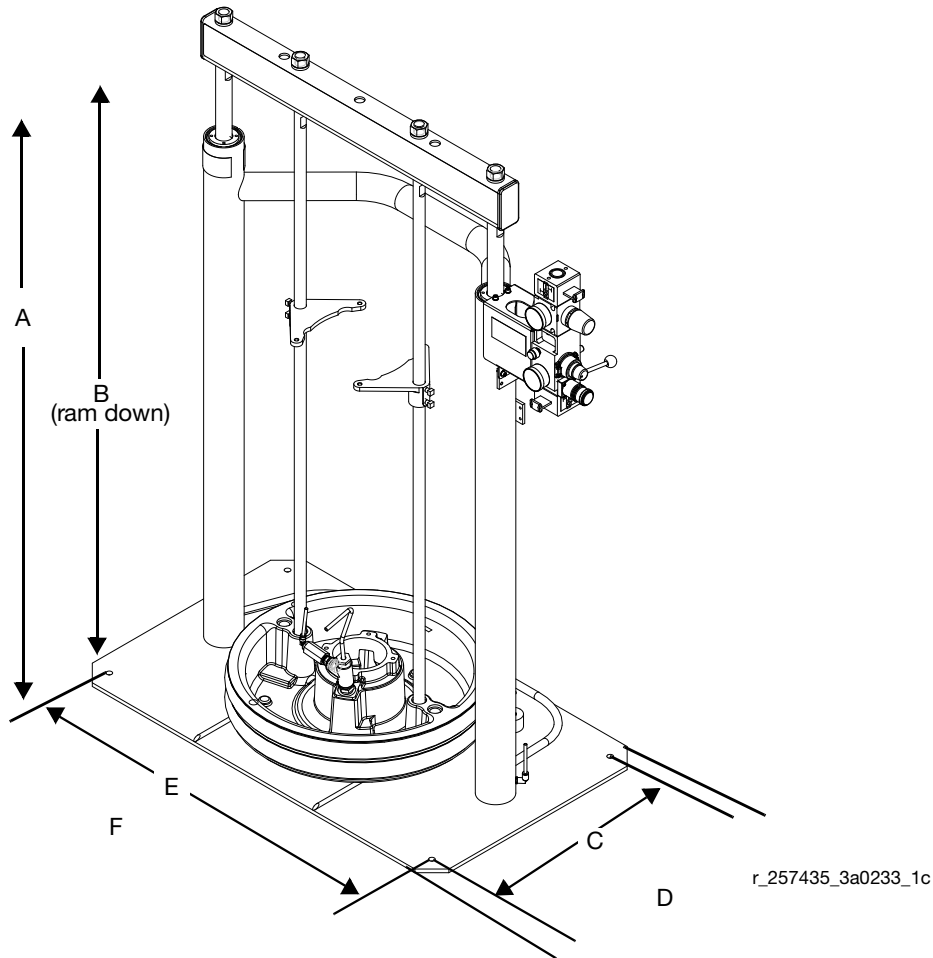

Ram Model	A in. (mm)	B in. (mm)	C in. (mm)	D in. (mm)	E in. (mm)	F in. (mm)
D200	102.3 (2599)	64.8 (1646)	21.0 (533)	25.0 (635)	38.0 (965)	42.0 (1067)

Weight

Platen Size Gallons (Liters)	Maximum Weight
55 (200)	51 (23)

Technical Data

Max air input pressure (ram) / Air inlet size D200 - 3 in. dual post, 55 gal. (200 L), 30 gal. (115 L)	150 psi (1.0 MPa, 10 bar) / 3/4 npt(f)
Max fluid, air working pressure, and weight (displacement pump)	For Check-Mate pump packages, see manual 312376. For Dura-Flo pump packages, see manuals 311826, 311828, 311833.
Wetted Parts	
Displacement pump	For Check-Mate displacement pumps, see manual 312375. For Dura-Flo displacement pumps, see manuals 311717, 311825, 311827.
Platens	
255663, 55 gal. (200 L)	EPDM, aluminum, zinc plated carbon steel, 316 sst
255664, 55 gal. (200 L)	PTFE, neoprene, aluminum, zinc plated carbon steel, 316 sst
25R468, 55 gal. (200 L)	NITRILE, aluminum, zinc plated steel, 316 sst
Ambient operating temperature range (ram)	32-120 °F (0- 49°C)

California Proposition 65

CALIFORNIA RESIDENTS

 **WARNING:** Cancer and reproductive harm – www.P65warnings.ca.gov.

Graco Standard Warranty

Graco warrants all equipment referenced in this document which is manufactured by Graco and bearing its name to be free from defects in material and workmanship on the date of sale to the original purchaser for use. With the exception of any special, extended, or limited warranty published by Graco, Graco will, for a period of twelve months from the date of sale, repair or replace any part of the equipment determined by Graco to be defective. This warranty applies only when the equipment is installed, operated and maintained in accordance with Graco's written recommendations.

This warranty does not cover, and Graco shall not be liable for general wear and tear, or any malfunction, damage or wear caused by faulty installation, misapplication, abrasion, corrosion, inadequate or improper maintenance, negligence, accident, tampering, or substitution of non-Graco component parts. Nor shall Graco be liable for malfunction, damage or wear caused by the incompatibility of Graco equipment with structures, accessories, equipment or materials not supplied by Graco, or the improper design, manufacture, installation, operation or maintenance of structures, accessories, equipment or materials not supplied by Graco.

This warranty is conditioned upon the prepaid return of the equipment claimed to be defective to an authorized Graco distributor for verification of the claimed defect. If the claimed defect is verified, Graco will repair or replace free of charge any defective parts. The equipment will be returned to the original purchaser transportation prepaid. If inspection of the equipment does not disclose any defect in material or workmanship, repairs will be made at a reasonable charge, which charges may include the costs of parts, labor, and transportation.

THIS WARRANTY IS EXCLUSIVE, AND IS IN LIEU OF ANY OTHER WARRANTIES, EXPRESS OR IMPLIED, INCLUDING BUT NOT LIMITED TO WARRANTY OF MERCHANTABILITY OR WARRANTY OF FITNESS FOR A PARTICULAR PURPOSE.

Graco's sole obligation and buyer's sole remedy for any breach of warranty shall be as set forth above. The buyer agrees that no other remedy (including, but not limited to, incidental or consequential damages for lost profits, lost sales, injury to person or property, or any other incidental or consequential loss) shall be available. Any action for breach of warranty must be brought within two (2) years of the date of sale.

GRACO MAKES NO WARRANTY, AND DISCLAIMS ALL IMPLIED WARRANTIES OF MERCHANTABILITY AND FITNESS FOR A PARTICULAR PURPOSE, IN CONNECTION WITH ACCESSORIES, EQUIPMENT, MATERIALS OR COMPONENTS SOLD BUT NOT MANUFACTURED BY GRACO. These items sold, but not manufactured by Graco (such as electric motors, switches, hose, etc.), are subject to the warranty, if any, of their manufacturer. Graco will provide purchaser with reasonable assistance in making any claim for breach of these warranties.

In no event will Graco be liable for indirect, incidental, special or consequential damages resulting from Graco supplying equipment hereunder, or the furnishing, performance, or use of any products or other goods sold hereto, whether due to a breach of contract, breach of warranty, the negligence of Graco, or otherwise.

FOR GRACO CANADA CUSTOMERS

The Parties acknowledge that they have required that the present document, as well as all documents, notices and legal proceedings entered into, given or instituted pursuant hereto or relating directly or indirectly hereto, be drawn up in English. Les parties reconnaissent avoir convenu que la rédaction du présente document sera en Anglais, ainsi que tous documents, avis et procédures judiciaires exécutés, donnés ou intentés, à la suite de ou en rapport, directement ou indirectement, avec les procédures concernées.

Graco Information

For the latest information about Graco products, visit www.graco.com.

For patent information, see www.graco.com/patents.

TO PLACE AN ORDER, contact your Graco distributor or call to identify the nearest distributor.

Toll Free Phone Number: 1-800-328-0211

All written and visual data contained in this document reflects the latest product information available at the time of publication. Graco reserves the right to make changes at any time without notice.

For patent information, see www.graco.com/patents.

Original instructions. This manual contains English. MM 3A0233

Graco Headquarters: Minneapolis

International Offices: Belgium, China, Japan, Korea

GRACO INC. AND SUBSIDIARIES • P.O. BOX 1441 • MINNEAPOLIS MN 55440-1441 • USA

Copyright 2009, Graco Inc. All Graco manufacturing locations are registered to ISO 9001.

www.graco.com

Revision L, July 2024