

InvisiPac[®] Pattern Controller

334784N

EN

***To control fluid dispense valves of adhesive supply equipment. For professional use only.
Not approved for use in explosive atmospheres or hazardous locations.***

See page 3 for model information and Agency approvals.



Important Safety Instructions

Read all warnings and instructions in this manual and related manuals. Save these instructions.

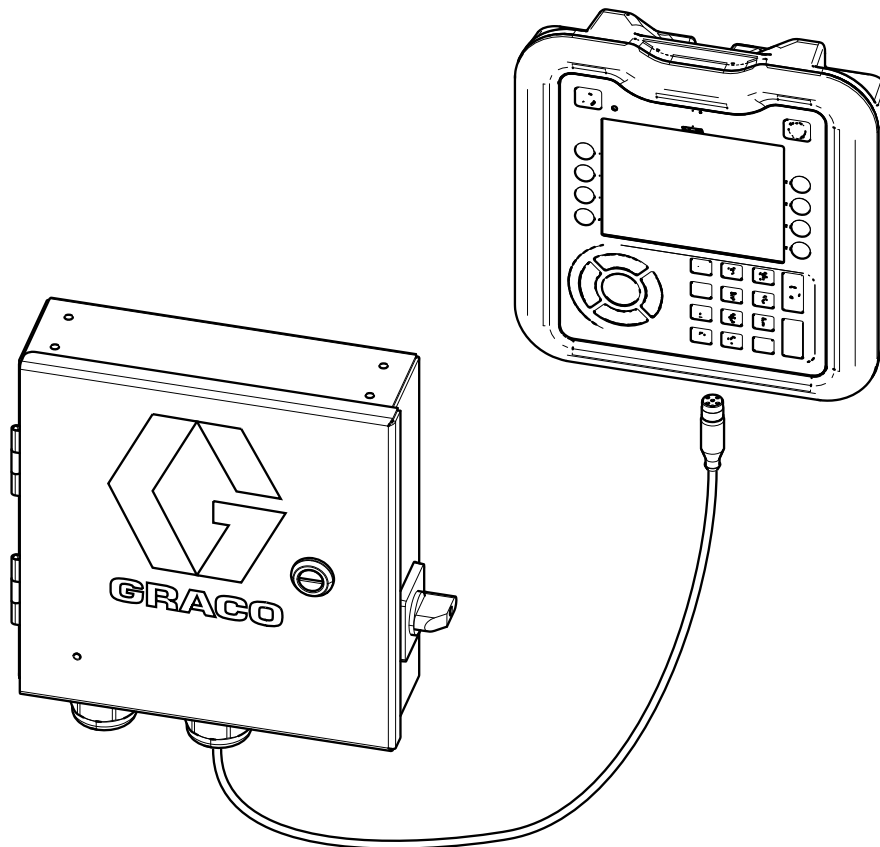

ti25530a

Contents

Models	3	Calibration	40
Approvals	3	Gun Compensation (optional)	40
Related Manuals	3	Line Speed	41
Warnings	4	Run Up Control (PC-8e only)	42
Overview	7	Modulated Bead (PC-8e Only)	43
Component Identification (Internal Models - HM25c) 8		Verification	44
Component Identification (Internal Models - HM25 and HM50)	9	Valves	44
Component Identification (External Models) ..	10	Triggers	44
Installation - Internal Models (HM25c)	11	Encoder	44
Connect Pattern Control Board	11	Run Up Control	44
Installation - Internal Models (HM25 and HM50)	12	PLC Inputs	44
Connect Pattern Control Board	12	Troubleshooting	45
Connect Power Supply and Advanced Display Module	13	Error Codes	45
Install Control Board into InvisiPac System ..	14	Display	46
Installation - External Models	15	Pattern	46
Mounting	15	Valve	48
Connect Advanced Display Module (ADM)	15	Trigger	48
Connect Pattern Control Board	16	Encoder	48
Connect Electrical Cord	17	Run Up	49
Wire Pattern Control Board	18	PLC Inputs and Outputs	49
Valve Installation	18	Software Update Procedure	50
Trigger Installation	18	USB Download	51
PLC Inputs and Outputs Installation (optional) .	19	Download Procedure	51
Encoder Installation (PC-8e only)	20	Accessing Files	51
Run Up Installation (PC-8e only)	20	Upload Procedure	51
Initial Startup	21	USB Logs	52
Software Update	21	System Settings File	52
Key Token	21	System Language File	53
Screens	22	Parts	54
Screen Maps	22	External Models	54
HMI Interface	23	Internal Models (HM25c)	56
PC Screens	24	Internal Models (HM25 and HM50)	57
Advanced Screens	35	Kits	58
Stitching	37	Wiring Diagrams	61
Random Length Bead Mode	38	Internal Pattern Controller (HM25 and HM50 Systems with AWB)	61
Mirror Mode	39	Internal Pattern Controller (HM25 Systems with DIN Rail)	62
		External Models	63
		Dimensioned Drawings	64
		Technical Specifications	67
		California Proposition 65	67
		Graco Standard Warranty	68

Models

Internal Models (HM25c)

Used to upgrade InvisiPac HM25c systems to include pattern control.

Part	Type	Description	Contents
25M526	PC-8*	Time or distance mode, no encoder	Pattern controller

* Order kit 17F712 to upgrade to PC-8e.

Internal Models (HM25 and HM50)

Used to upgrade InvisiPac HM25 and HM50 systems to include pattern control.

Part	Type	Description	Contents
24X640	PC-8	Time or distance mode, no encoder	Internal pattern controller
24X641	PC-8e	Time or distance mode, with or without encoder Run up control (optional)	Internal pattern controller Key token for encoder and run up

External Integrated Models

Used to connect a separate pattern control enclosure to an InvisiPac system (compatible with all InvisiPac systems)

Part	Type	Description	Contents
24X523	PC-8	Time or distance mode, no encoder	Pattern controller
24X524	PC-8e	Time or distance mode, with or without encoder Run up control (optional)	Pattern controller Key token for encoder and run up

External Stand Alone Models

Used for applications without an InvisiPac system

Part	Type	Description	Contents
24X525	PC-8	Time or distance mode, no encoder	Pattern controller Advanced display module
24X526	PC-8e	Time or distance mode, with or without encoder Run up control (optional)	Pattern controller Advanced display module Key token for encoder and run up

Approvals



Part	Description	Approvals
127971	External pattern controller	CE, ETL, cETL
24W293	Internal pattern controller (HM25c)	CE, ETL, cETL
24X521	Internal pattern controller (HM25 and HM50)	CE, ETL, cETL
24E451	Advanced display module	CE, ETL, cETL

Related Manuals

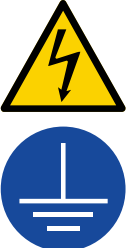

Part	Description
3A4938	InvisiPac HM25c Tank-Free™ Hot Melt Delivery System
333347	InvisiPac HM25 and HM50 Tank-Free™ Hot Melt Delivery System
334934	Run Up Pressure Kit

Warnings

The following warnings are for the setup, use, grounding, maintenance, and repair of this equipment. The exclamation point symbol alerts you to a general warning and the hazard symbols refer to procedure-specific risks. When these symbols appear in the body of this manual or on warning labels, refer back to these Warnings. Product-specific hazard symbols and warnings not covered in this section may appear throughout the body of this manual where applicable.

 <h2 style="margin: 0;">WARNING</h2>	
	<p>ELECTRIC SHOCK HAZARD</p> <p>This equipment must be grounded. Improper grounding, setup, or usage of the system can cause electric shock.</p> <ul style="list-style-type: none"> • Turn off and disconnect power at main switch before disconnecting any cables and before servicing or installing equipment. • Connect only to grounded power source. • All electrical wiring must be done by a qualified electrician and comply with all local codes and regulations.
	<p>EQUIPMENT MISUSE HAZARD</p> <p>Misuse can cause death or serious injury.</p> <ul style="list-style-type: none"> • Do not operate the unit when fatigued or under the influence of drugs or alcohol. • Do not exceed the maximum working pressure or temperature rating of the lowest rated system component. See Technical Specifications in all equipment manuals. • Use fluids and solvents that are compatible with equipment wetted parts. See Technical Specifications in all equipment manuals. Read fluid and solvent manufacturer's warnings. For complete information about your material, request MSDS from distributor or retailer. • Do not leave the work area while equipment is energized or under pressure. • Turn off all equipment and follow the Pressure Relief Procedure when equipment is not in use. • Check equipment daily. Repair or replace worn or damaged parts immediately with genuine manufacturer's replacement parts only. • Do not alter or modify equipment. Alterations or modifications may void agency approvals and create safety hazards. • Make sure all equipment is rated and approved for the environment in which you are using it. • Use equipment only for its intended purpose. Call your distributor for information. • Route hoses and cables away from traffic areas, sharp edges, moving parts, and hot surfaces. • Do not kink or over bend hoses or use hoses to pull equipment. • Keep children and animals away from work area. • Comply with all applicable safety regulations.
	<p>BURN HAZARD</p> <p>Equipment surfaces and fluid that is heated can become very hot during operation. To avoid severe burns.</p> <ul style="list-style-type: none"> • Do not touch hot fluid or equipment.

! WARNING

	<p>SKIN JECTION HAZARD</p> <p>High-pressure fluid from dispensing device, hose leaks, or ruptured components will pierce skin. This may look like just a cut, but it is a serious injury that can result in amputation. Get immediate surgical treatment.</p> <ul style="list-style-type: none"> • Do not point dispensing device at anyone or at any part of the body. • Do not put your hand over the fluid outlet. • Do not stop or deflect leaks with your hand, body, glove, or rag. • Follow the Pressure Relief Procedure when you stop dispensing and before cleaning, checking, or servicing equipment. • Tighten all fluid connections before operating the equipment. • Check hoses and couplings daily. Replace worn or damaged parts immediately.
	<p>MOVING PARTS HAZARD</p> <p>Moving parts can pinch, cut or amputate fingers and other body parts.</p> <ul style="list-style-type: none"> • Keep clear of moving parts. • Do not operate equipment with protective guards or covers removed. • Equipment can start without warning. Before checking, moving, or servicing equipment, follow the Pressure Relief Procedure and disconnect all power sources.
	<p>FIRE AND EXPLOSION HAZARD</p> <p>Flammable fumes, such as solvent and paint fumes, in work area can ignite or explode. To help prevent fire and explosion:</p> <ul style="list-style-type: none"> • Do not use solvent-based adhesives that can create an explosive atmosphere when processed. • Use equipment only in well-ventilated area. • Eliminate all ignition sources; such as pilot lights, cigarettes, portable electric lamps, and plastic drop cloths (potential static sparking). • Keep work area free of debris, including solvent, rags and gasoline. • Do not plug or unplug power cords, or turn power or light switches on or off when flammable fumes are present. • Ground all equipment in the work area. See Grounding instructions. • Use only grounded hoses. • Stop operation immediately if static sparking occurs or you feel a shock. Do not use equipment until you identify and correct the problem. • Keep a working fire extinguisher in the work area.



WARNING

**TOXIC FLUID OR FUMES HAZARD**

Toxic fluids or fumes can cause serious injury or death if splashed in the eyes or on skin, inhaled, or swallowed.

- Read Safety Data Sheets (SDSs) to know the specific hazards of the fluids you are using.
- Store hazardous fluid in approved containers, and dispose of it according to applicable guidelines.

**PERSONAL PROTECTIVE EQUIPMENT**

Wear appropriate protective equipment when in the work area to help prevent serious injury, including eye injury, hearing loss, inhalation of toxic fumes, and burns. Protective equipment includes but is not limited to:

- Protective eyewear, and hearing protection.
- Respirators, protective clothing, and gloves as recommended by the fluid and solvent manufacturer.

**PRESSURIZED ALUMINUM PARTS HAZARD**

Use of fluids that are incompatible with aluminum in pressurized equipment can cause serious chemical reaction and equipment rupture. Failure to follow this warning can result in death, serious injury, or property damage.

- Do not use 1,1,1-trichloroethane, methylene chloride, other halogenated hydrocarbon solvents or fluids containing such solvents.
- Do not use chlorine bleach.
- Many other fluids may contain chemicals that can react with aluminum. Contact your material supplier for compatibility.

Overview

InvisiPac pattern control systems can be integrated with InvisiPac systems or stand alone with any other equipment. For all installations, the advanced display module (ADM) is used to make programming easy.

PC-8 controllers operate in time or distance mode without an encoder. Up to 8 guns and 4 independent triggers are supported.

PC-8e controllers include the same features as PC-8 with the addition of distance based control using an encoder, and run up control using an I/P or V/P pressure regulator.

Features of the PC-8 and PC-8e:

Feature	Details
Gun outputs	8
Trigger inputs	4
Encoder	2 (PC-8e only)
Run up control	2 (PC-8e only)
Program storage	50
PLC enable / disable	Yes
PLC alarm output	Yes
PLC program select	Yes
Password protection	Yes
Integrated power supply	Yes

For more information, see **Technical Specifications**, page 67.

Component Identification (Internal Models - HM25c)

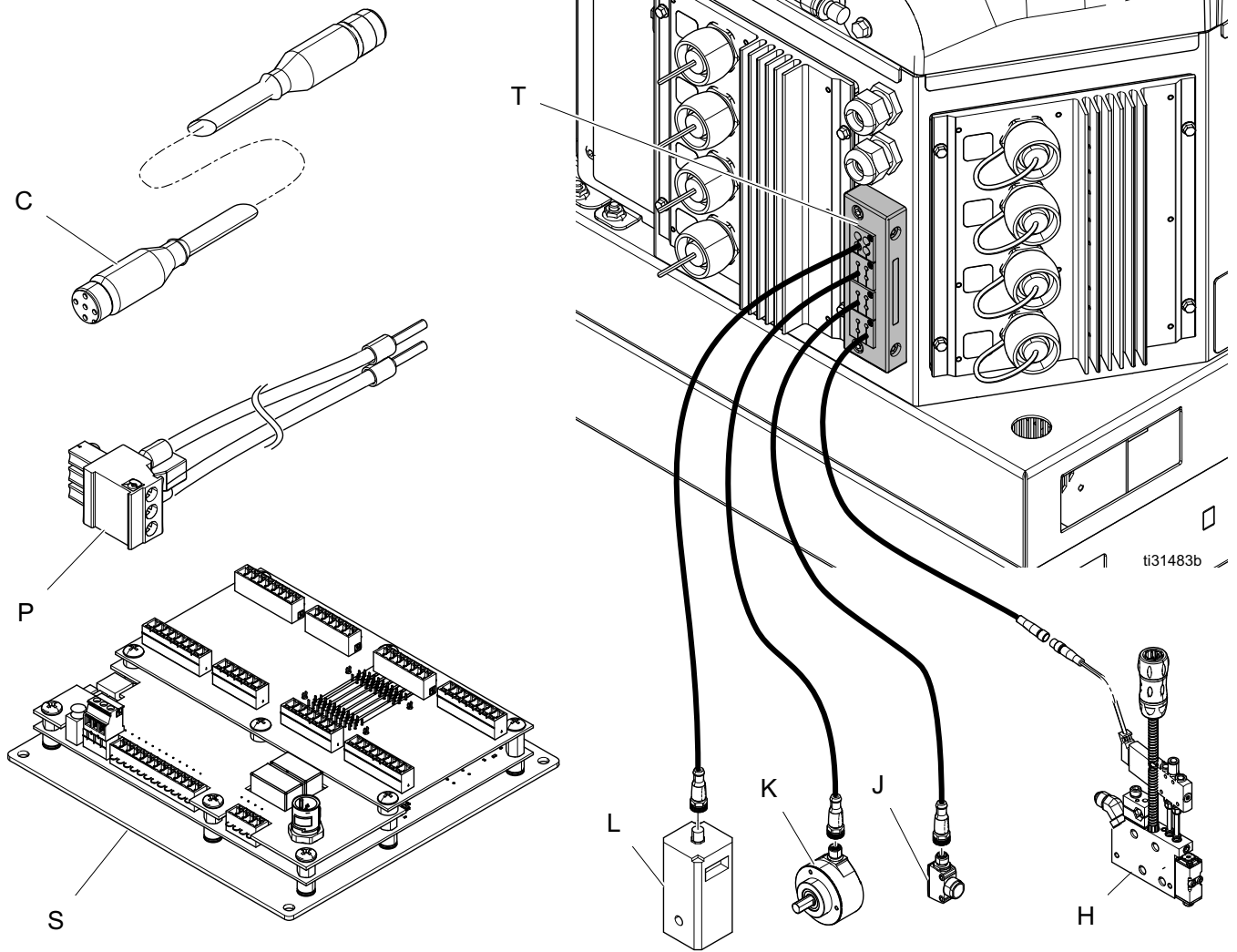

Key

- C Communication cable
- H Valve
- J Trigger
- K Encoder

Key

- L Run up
- P Power harness
- S Control board
- T Cord grip

Component Identification (Internal Models - HM25 and HM50)

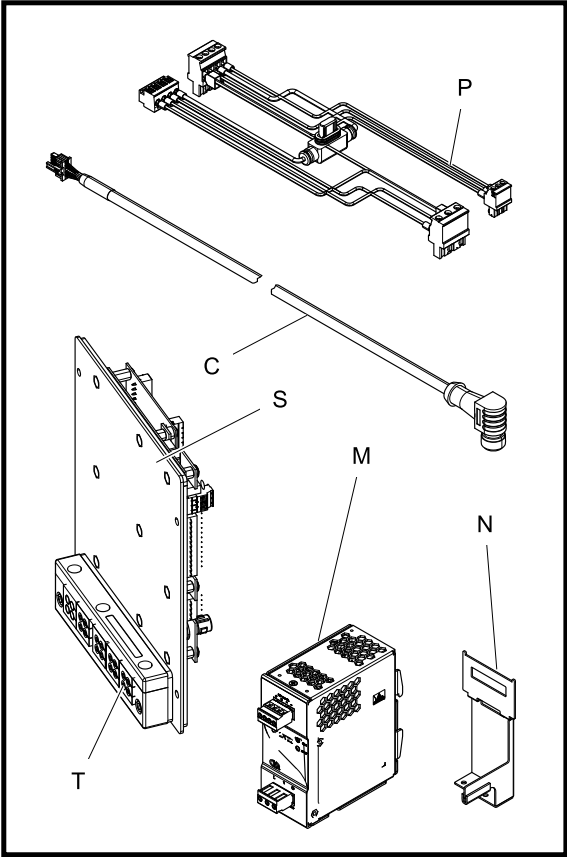

- Key**
- C Communication cable
 - H Valve
 - J Trigger
 - K Encoder
 - L Run Up

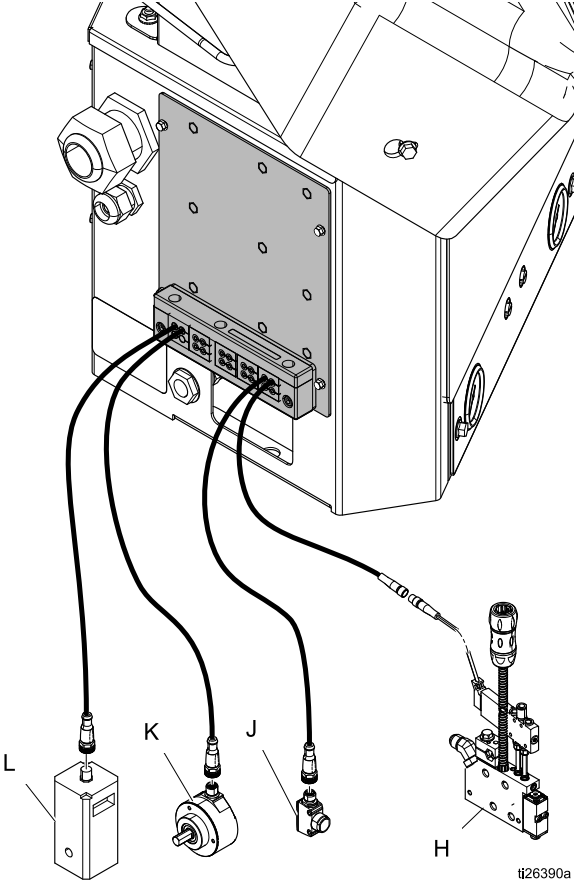

Installed onto InvisiPac System

- Key**
- M Power supply
 - N Power supply bracket
 - P Power harness
 - S Control board
 - T Cord grip

Component Identification (External Models)

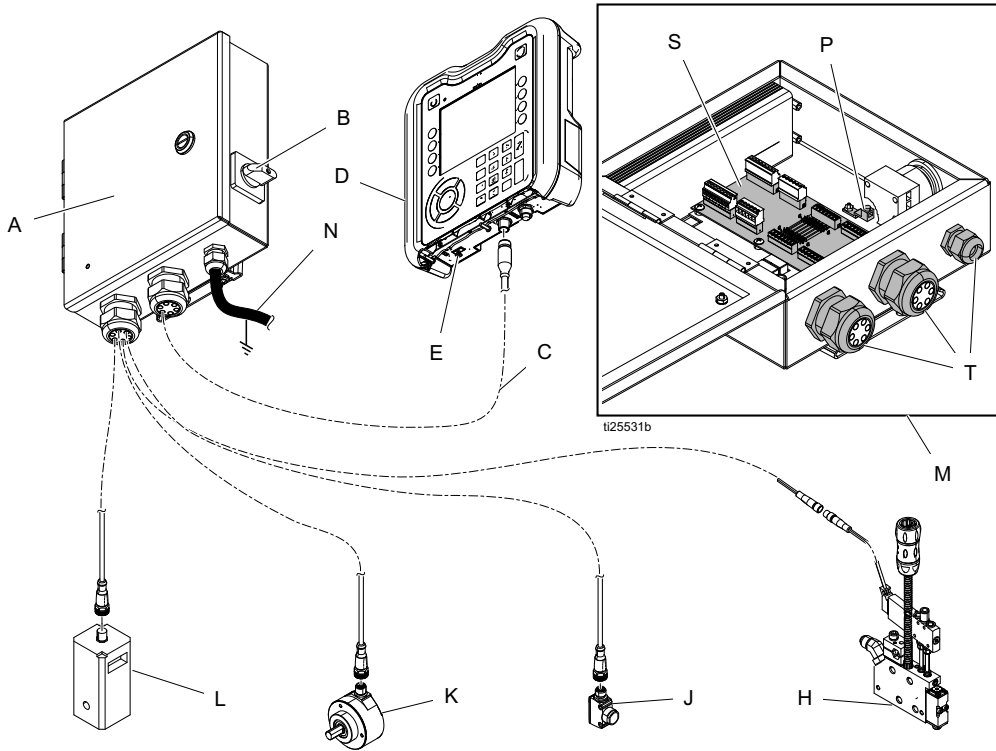

Key

- A Pattern controller
- B Power switch
- C Communication cable
- D ADM
- E USB port
- H Valve
- J Trigger

Key

- K Encoder
- L Run up
- M Inside view of pattern controller
- N Customer power board (not included)
- P Ground terminal
- S Control board
- T Cord grips (I/O x2 power)

Installation - Internal Models (HM25c)

Connect Pattern Control Board

1. Set pattern control system type selector switch to 0.

NOTE: The system must be powered off for a change in system type to have an effect.

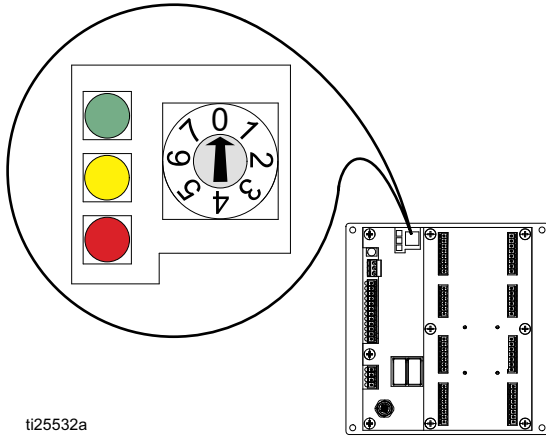

ti25532a

2. Remove cord grip assembly (T) from back of InvisiPac system and remove inserts. Inserts with grip tightly on most M8 and M12 cables and expand and compress to accept cables larger than the apparent hole size.
3. Install valve signal wires, trigger signal wires, PLC wires (optional). See **Wire Pattern Control Board**, page 18.
4. Route cables through the opening in the back of the InvisiPac enclosure as shown.
5. Apply cord grip inserts over cables and replace into frame. Replace frame onto back of InvisiPac enclosure.
6. Remove excess slack from the cables but do not pull tight. Tighten cord grip frame on inserts to secure.

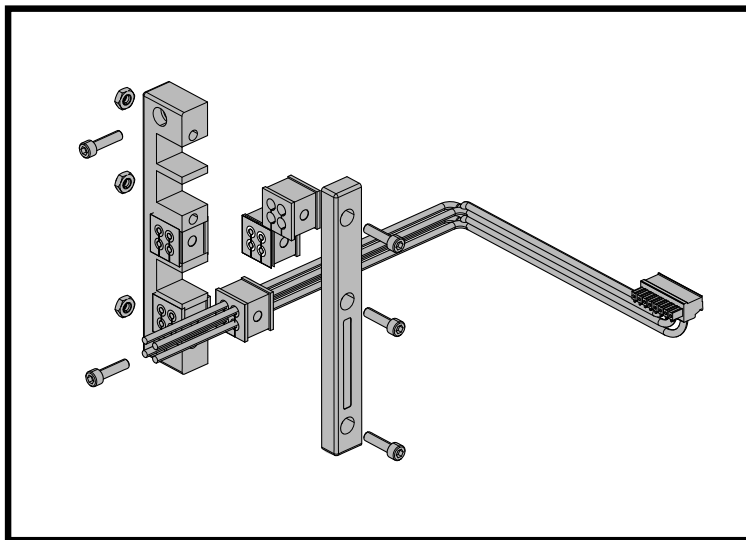

ti31480a

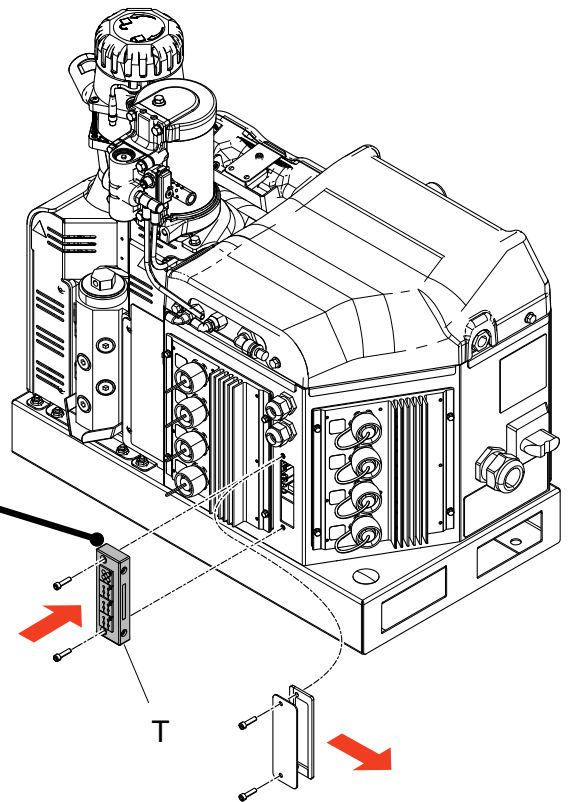

Installation - Internal Models (HM25 and HM50)

Connect Pattern Control Board

1. Set pattern control system type selector switch to 0.

NOTE: The system must be powered off for a change in system type to have an effect.

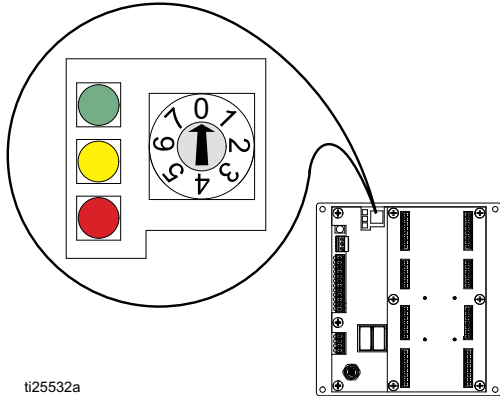

ti25532a

2. Remove cord grip assembly (T) from pattern control board (S) and remove inserts. Inserts will grip tightly on most M8 and M12 cables and will expand and compress to accept cables larger than the apparent hole size.
3. Install valve signal wires, trigger signal wires, PLC wires (optional) and encoder and run up wires (PC-8e only). See **Wire Pattern Control Board**, page 18.
4. Route cables through the opening in the pattern control board back panel as shown.
5. Apply cord grip inserts over cables and replace into frame. Replace frame onto pattern control panel.
6. Remove excess slack from cables but do not pull tight. Tighten cord grip frame on inserts to secure.

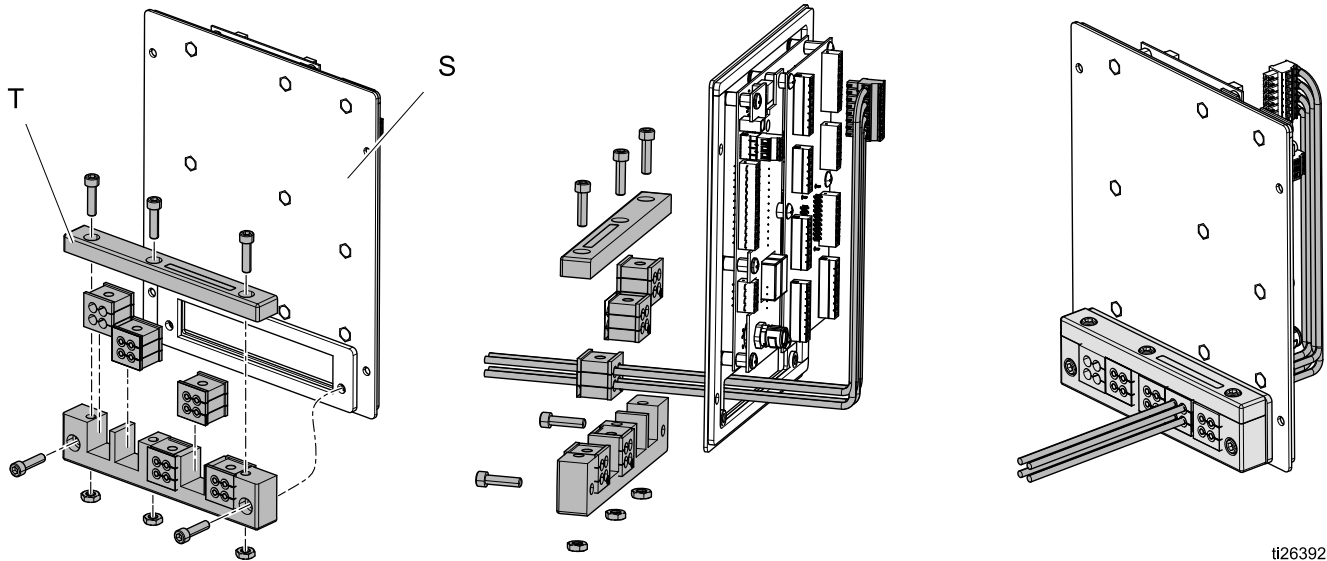

ti26392a

Connect Power Supply and Advanced Display Module

NOTE: If the internal pattern controller is being installed into a first generation HM25 with DIN rail writing, additional connections must be made.

Install Kit 24Y171 has the necessary components and instructions to perform this installation. See **Kits**, page 58.

1. Turn main power switch OFF.
2. Remove panel door, then remove blanking plate from left-hand side of system electrical enclosure.

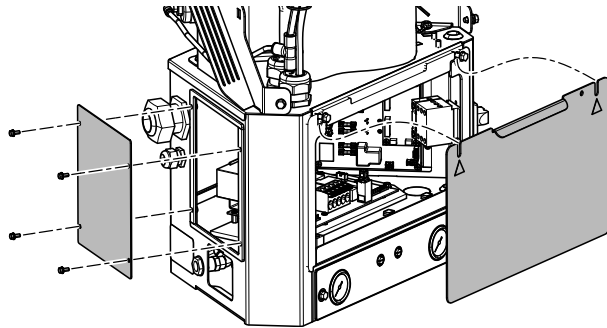

ti26393a

3. Remove connector from AWB terminal pins J1 and remove the power supply and harness from mounting bracket. Unscrew mounting bracket from AWB.

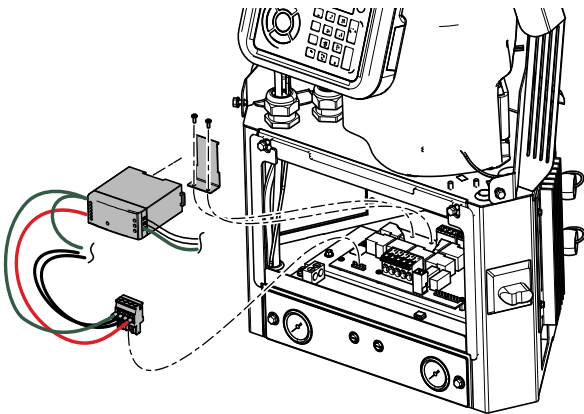

ti26394a

4. Connect communication cable (C) to open J3 connector (or J6, if J3 is used) on MZLP board. If connecting to MZLP #2, loop extra cable length along edge of electrical enclosure.

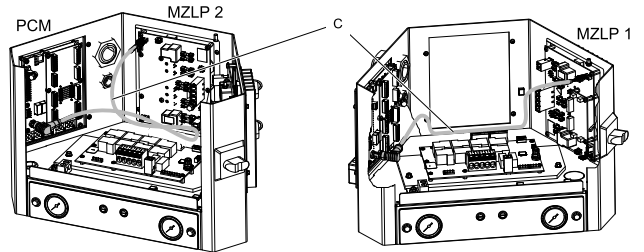

ti26395a

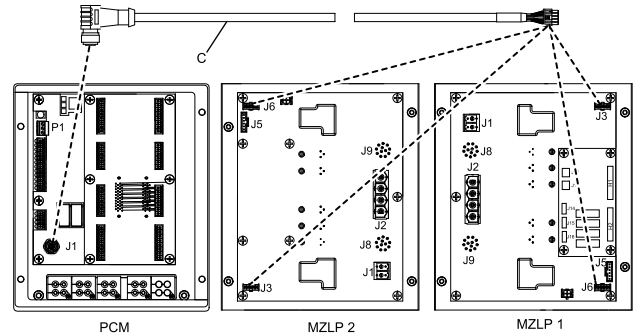

ti26395a

5. Remove blue connectors from terminals of power supply W and discard or set aside. Install new power supply bracket (N) onto AWB and clip new power supply (M) into place.

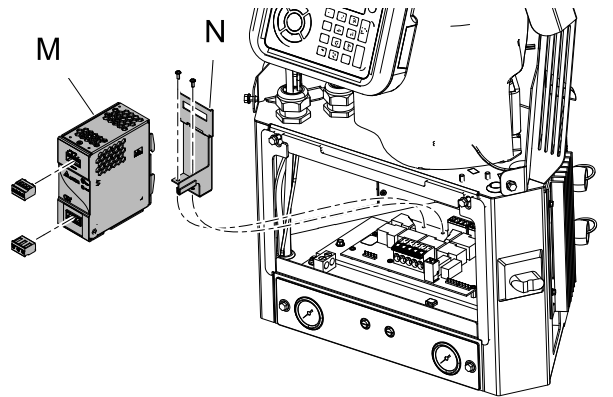

ti26397a

6. Connect power harness (P) to AWB terminal pins J1 and the input and output terminals of power supply.

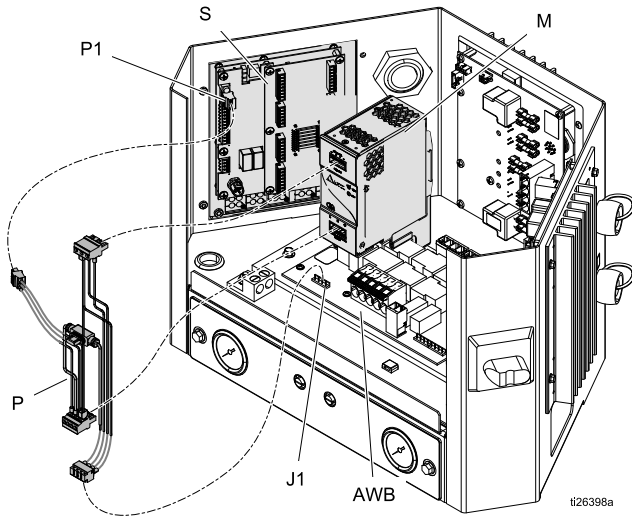

Install Control Board into InvisiPac System

1. Mount board into open space on left-hand side of electrical enclosure. Use serrated-flange screws.
2. Connect power harness to power control board terminal P1, and connect communication cable to pattern control board terminal P4.

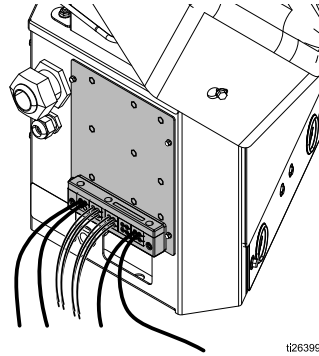

3. Replace system electrical enclosure door.

Installation - External Models

Mounting

The pattern controller and ADM can be mounted using the included VESA-compatible brackets and mounting software.

1. Unscrew the two lower screws to uncouple the “wall” portion of the bracket.
2. Securely mount the bracket in the desired location.
3. Slide the controller onto the bracket and tighten the two screws for permanent fastening.

ALTERNATIVE METHOD: Remove mounting hardware and mount directly to any surface.

NOTE: Make sure at least 13 in. of clearance is available above the top of the mounting bracket in order to slide the enclosure in and out of the wall mount.

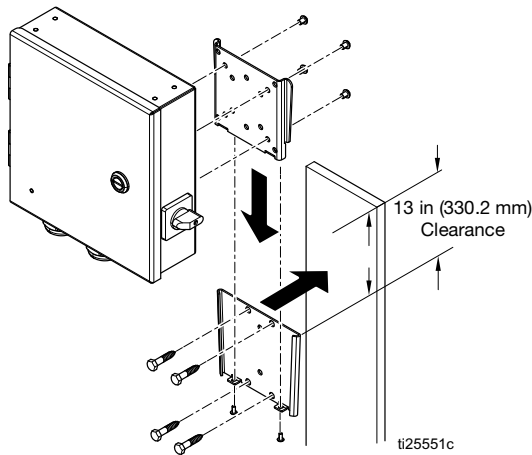

NOTE: To make repairing the system easier, locate the system so that it is easily accessible and has sufficient lighting.

Connect Advanced Display Module (ADM)

Integrate with InvisiPac HM25c

1. Set pattern control system type selector switch to 0.

NOTE: The system must be powered off for a change in system type to have an effect.

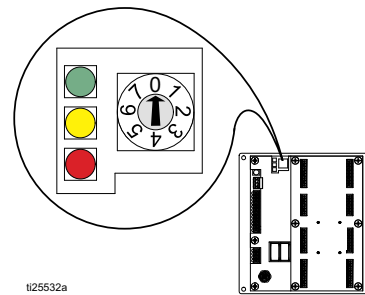

2. Disconnect the CAN cable from the ADM (D) and connect it to one of the male ends of the splitter (2).

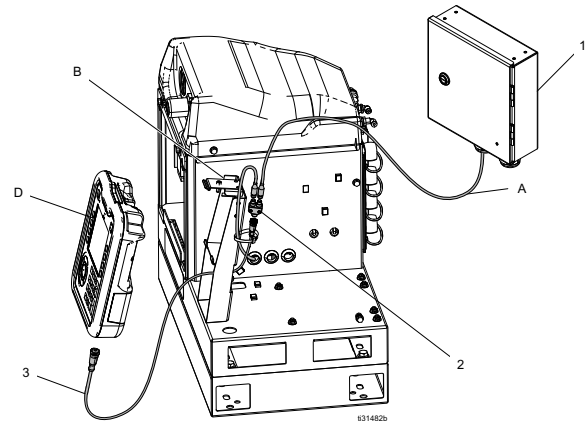

3. Connect the CAN cable from the pattern controller enclosure (A) to the other male end of the splitter (2).
4. Connect the male end of the short CAN cable contained in the pattern controller kit (3) to the female end of the splitter (2).
5. Connect female end of the short CAN cable (3) to the ADM.
6. Use zip ties to attach the CAN cables and splitter to the ADM bracket (B).

Integrate with InvisiPac (HM25 or HM50)

1. Set pattern control system type selector switch to 0.

NOTE: The system must be powered off for a change in system type to have an effect.

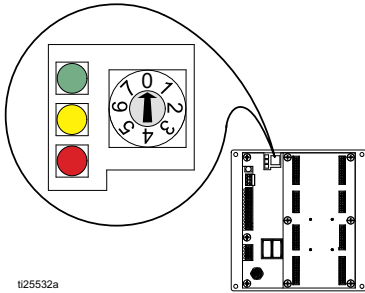

ti25532a

2. Disconnect the CAN cable from the ADM (D), push the cable through the plastic shroud (B), the remove the shroud from the system.

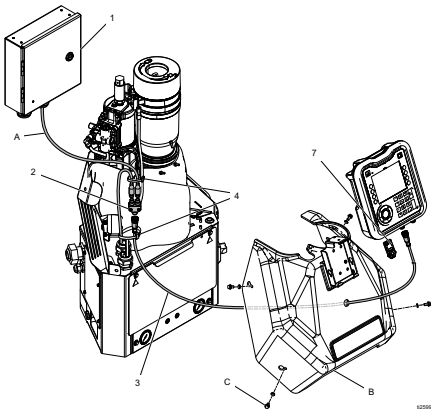

ti25591a

3. Connect the CAN cable from the ADM (D) to one of the male ends of the splitter (2).
4. Connect the CAN cable from the pattern controller (A) to the other male end of the splitter (2).
5. Connect the male end of the short CAN cable contained in pattern controller kit (3) to the female end of the splitter.
6. Push the free end of the short CAN cable (3) through the shroud and connect the female end to the ADM.
7. Use zip ties (4) to attach the CAN cable bundle to the other vertical bundle of cables.

Stand Alone

1. Set the pattern control system type selector switch to 1.

NOTE: The system must be powered off for a change in system type to have an effect.

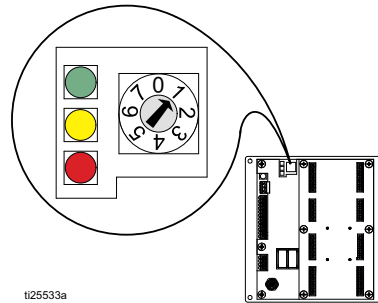

ti25533a

2. Mount the ADM using the provided bracket
3. Connect the CAN cable (C) between the pattern controller and the ADM

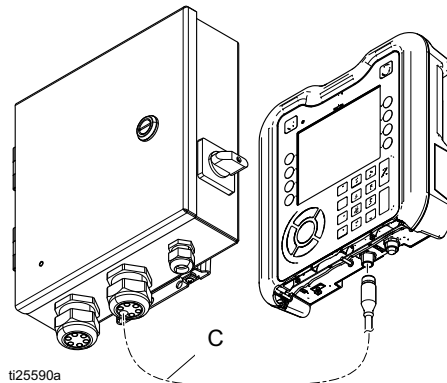



ti25590a

Connect Pattern Control Board

See **Wire Pattern Control Board**, page 18.

1. Install triggers and valves
2. Install PLC inputs and outputs (optional)
3. Install encoder (PC-8e only)
4. Install run up (optional, PC-8e only)

Connect Electrical Cord

				
---	---	---	--	--

Improper wiring may cause electric shock or other serious injury if work is not performed properly. Have a qualified electrician perform any electrical work. Be sure your installation complies with all National, State, and Local safety and fire codes.

The equipment must be grounded to reduce the risk of electric shock. Improper grounding can cause electric shock. Grounding provides an escape wire for the electric current.

The pattern controller system is equipped with a ground terminal. Have a qualified electrician ground the system using this terminal.

Electrical power enters through the smaller cord grip on the right side of the enclosure (see figure). The power cord can be further secured inside the enclosure with the provided zip-tie and tie mount.

1. Install power wires (L1/L2 or L/N) into terminals 2 and 4 on the disconnect switch, see page 63. The switch accepts solid or stranded 12 AWG and 14 AWG wire. For ratings, see **Technical Specifications**, page 67.

NOTE: The power switch housing can be removed for easy wiring using the red tab on top of the switch.

2. Connect earth ground to the grounding terminal.
3. Verify that the cord grip securely tightens around the power cord. Use a wrench to tighten, if necessary.

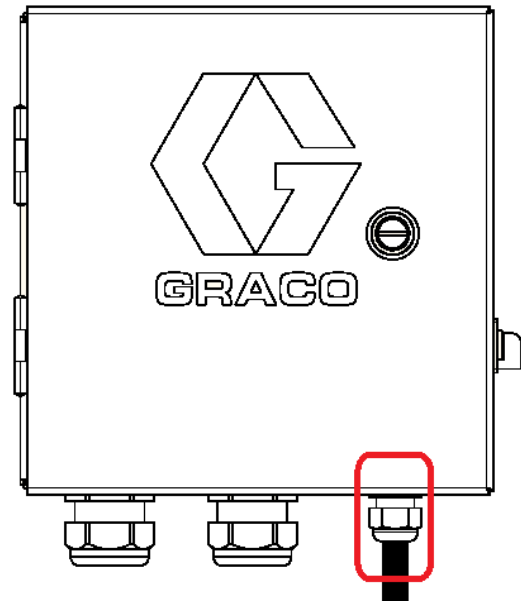

Wire Pattern Control Board

Valve Installation

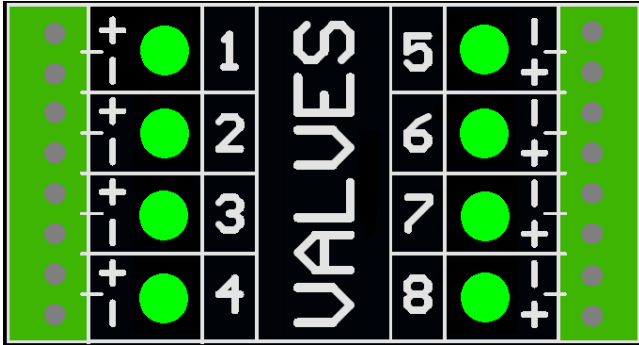

1. Connect up to 8 valves.

NOTE: Control voltage is 24 VDC with a limit of 1 amp per output and 6 amps total.

NOTE: Green LEDs indicate the status of each valve.

NOTE: DIN cable black wires are labeled 1 and 2. 1 is plus and 2 is minus.

Standard Wiring Colors			
Terminal Cable	Function	M8 Cable	DIN Cable
Plus (+)	24V Supply	Brown	Black 1
Minus (-)	Return	Blue	Black 2

Trigger Installation

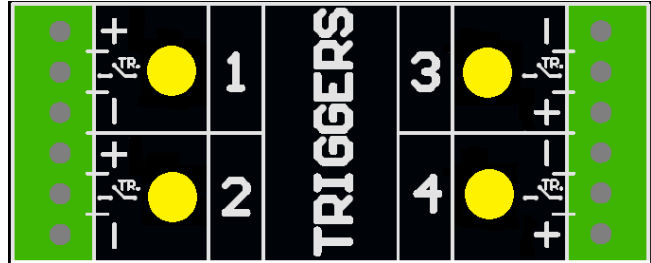

1. Connect up to 4 NPN, PNP, or dry contact triggers.

NOTE: Supplied voltage (+) is 24 VDC

2. Connect the two wires between TR and minus (-) to install a dry contact.

NOTE: Yellow LEDs indicate the status of each trigger. Polarity can be inverted if needed. See **Trigger Setup**, page 31.

Standard Wiring Colors		
Terminal	Function	M8 or M12 Cable
Plus (+)	24V Supply	Brown
TR	NPN, PNP, or dry contact	Black or white
Minus (-)	Return (or dry contact)	Blue

PLC Inputs and Outputs Installation (optional)

Functions:

	Type	Function	Description
	Input	ENABLE	Turns the controller on and off (rising edge enables, falling edge disables). Integrated systems: Turn the heat on/off using the InvisiPac PLC input (instead of this input). The pattern controller will be turned on by the InvisiPac system once the InvisiPac goes inactive.
		DISABLE	Disables the pattern controller (pull high to disable) NOTE: DISABLE polarity can be changed with the invert disable input setting. See General Setup (Screen 4), page 32.
		PROGRAM SELECT	Bits select a program to run (1-15) i.e. 1010 selects program #10 NOTE: 0000 disables PLC selection (local program selection ADM)
	Output	ALARM 1	Relay opens for active alarm(s) on Line 1
ALARM 2		Relay opens for active alarm(s) on Line 2	

Specifications

Inputs

- Bipolar Input
- Electrically isolated
- 0-30 VDC
- Min. 10 VDC to assert
- Sinks 10 mA at 24 VDC

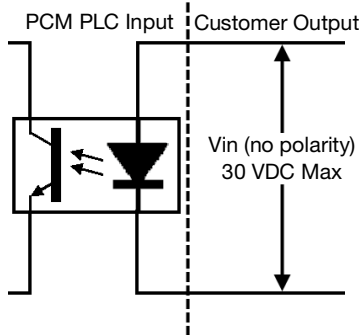

Outputs

- Dry contact output
- 0-24 VDC or 0-240 VAC
- 2A max

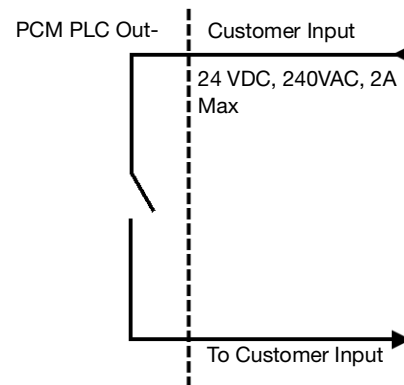

NOTE: To connect a dry contact signal, route GND to one terminal and connect 24 VDC signal through the dry contact to the other terminal (see image below).

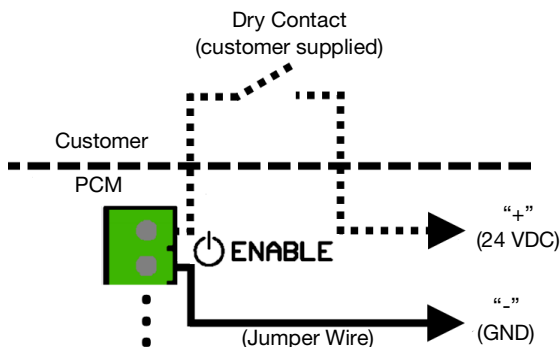

Alarms indicated by output relays. See **Troubleshooting Error Codes**, page 45 for more details.

Code	Description
A40P	Over-current on accessory power supply output
A4XP	Over-current on communication cable output
A4_P	Over-current on valve output “_”
K4_P	Encoder “_” pulse rate exceeds maximum limit

Encoder Installation (PC-8e only)

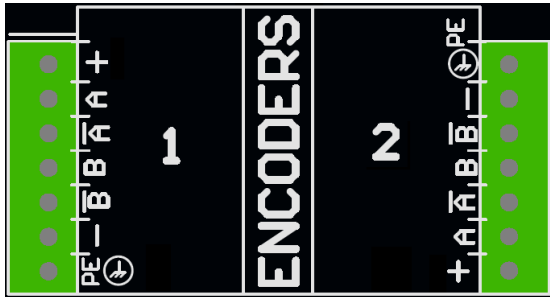

1. Connect up to two encoders to monitor line speed.

NOTE: Line 1 and line 2 on the ADM.

NOTE: Encoder type must be quadrature differential line driver (RS422). Scaling is entered in the encoder setup screen using the live calibration feature.

NOTE: Some encoders have Z and Z' connections. These are not used and do not need to be connected.

NOTE: Encoder direction can be reversed by swapping A and A' with B and B'. Do this is the line speed reads negative on the ADM.

Graco Encoder Wiring Diagram		
Terminal	Function	Wire Color
Plus	15V Supply	Red
A	Phase A signal (RS422)	Brown
A'	Phase A signal return	White
B	Phase B signal (RS422)	Yellow
B'	Phase B signal return	Green
Minus (-)	Return	Blue
PE	Shield	Bare

Run Up Installation (PC-8e only)



1. Connect up to two “I/P” or “V/P” run-up air pressure regulators to vary pump pressure based on line speed. Hardware automatically detects whether an I2P or V2P is connected.

NOTE: Pressure vs. line speed settings are entered on the run-up setup screen. See **Run Up Control**, page 42.

Standard Wire Colors		
Terminal	Function	M12 Cable
Plus (+)	24V Supply	Brown
%	Output to run-up	Black
Minus (-)	Return	Blue
Minus (-)	Return	White

Initial Startup

Software Update

When integrating into an InvisiPac system, the system may require a software update in order to be compatible with the pattern controller. Follow **Software Update Procedure**, page 50.

Key Token

For PC-8e models only, a key token is required to enable encoder and run up use.

1. Remove token access panel on back of ADM.

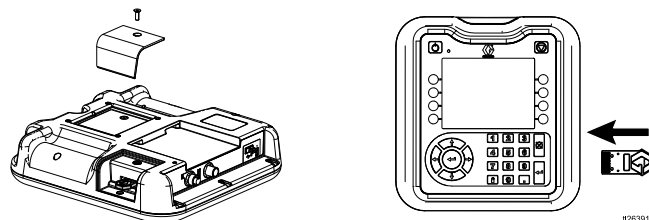

2. Insert blue key token 24X626 and press firmly into slot.
3. Replace cover, leaving key token inside.

Screens

Navigate through each screen to set up the pattern controller interface.

- Run screens include the home page and pattern definition.
- Setup screens contain configurable settings for each accessory.

Screen Maps

NOTE: On integrated InvisiPac system, additional chapters are present for hot melt HMI.

Run Screens

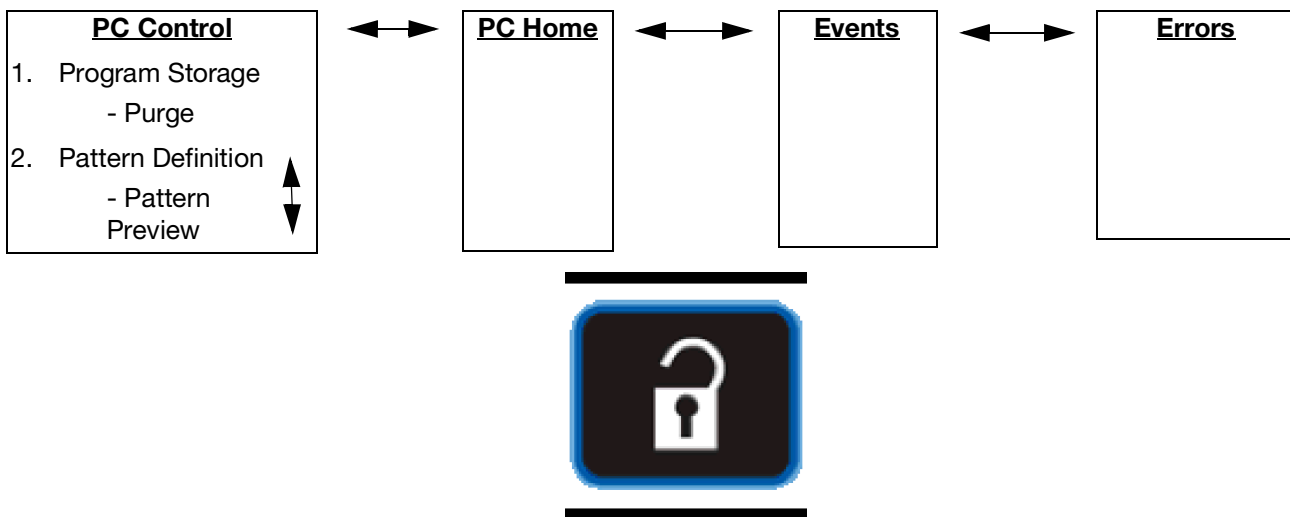

Press to switch between Run and Setup

Setup Screens

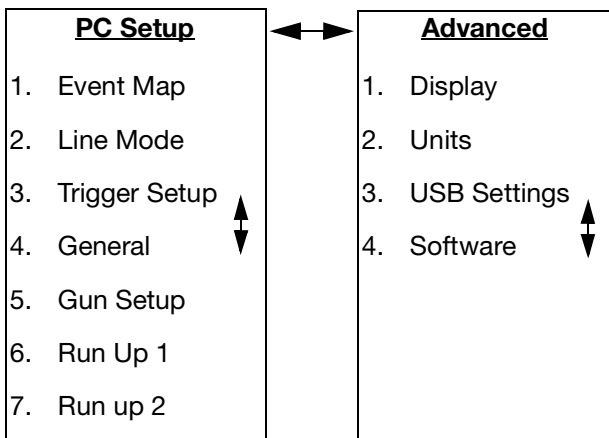

HMI Interface

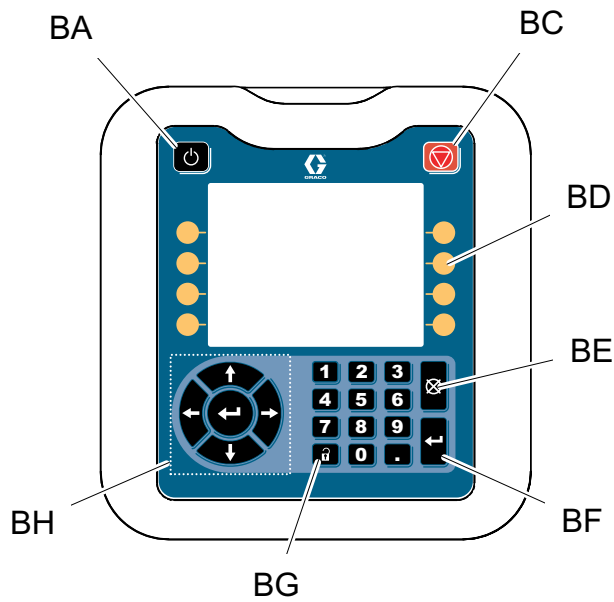

ti25542a

Key	Function
BA	Controller enable/disable
BC	Stop all system processes
BD	Defined by icon next to soft key
BE	Abort current operation
BF	Accept change, acknowledge error, select item, toggle selected item
BG	Toggle between run and setup screens
BH	Navigate within a screen or to a new screen





NOTICE

To prevent damage to soft key buttons, do not press the buttons with sharp objects such as pens, plastic cards, or fingernails.









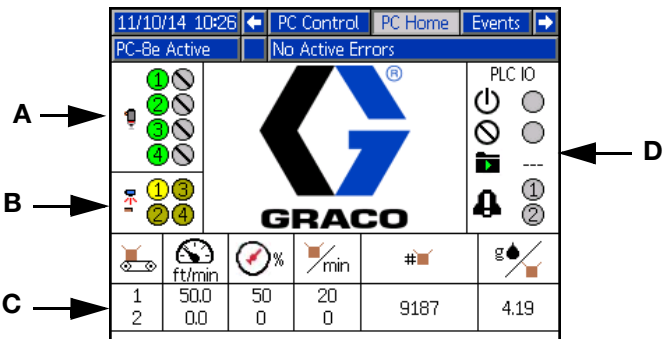



PC Screens

Home





Read-only view of pattern controller inputs and outputs:

1. Status of guns , triggers , and PLC signals.
2. Production rate /min, and units completed .
3. Material dispensed per product .

<p>A - Gun states B - Trigger states C - Line information D - PLC signals</p>	
--	--



Icon	Name	Description
	Gun	Gun status: active (green), enabled (gray), disabled (crossed out)
	Trigger	Trigger status: active (bright yellow), inactive (dark yellow)
	Line number	Line number for other display values in row
	Line speed	Current line speed (or fixed line speed setting)
	Run up output	Percentage of run up pressure range being output (PC-8e only)
	Production rate	Number of product per minute
	Product count	Total products completed. To configure and reset, see Trigger Setup (Screen 3) , page 31.
	Glue rate	Amount of glue per product (integrated InvisiPac systems only). NOTE: For best results, enter the appropriate specific gravity value for the adhesive material in use (see the InvisiPac system manual).
	PLC enable	State of enable signal from PLC
	PLC disable	State of disable signal from PLC
	Active program	Displays the active program chosen by the PLC (displays dashes if the PLC is not selecting a program)
	PLC alarm	Alarm status to the PLC (on line 1 or 2)

Program Storage (Screen 1)

1. Select program to load.
2. Copy program , erase program , or rename program .
3. Purge guns .
4. Lock/unlock controller for maintenance .

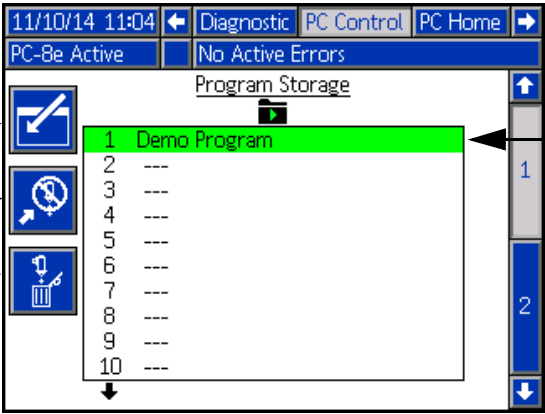

NOTE: Copy, erase, and rename capabilities are disabled if “Lock Pattern Definition” is enabled. See **General Setup**, page 32.

<p>A - Enter screen B - Maintenance lock/unlock C - To purge screen D - Active program P - Screen number (Screen 1)</p>	
--	---

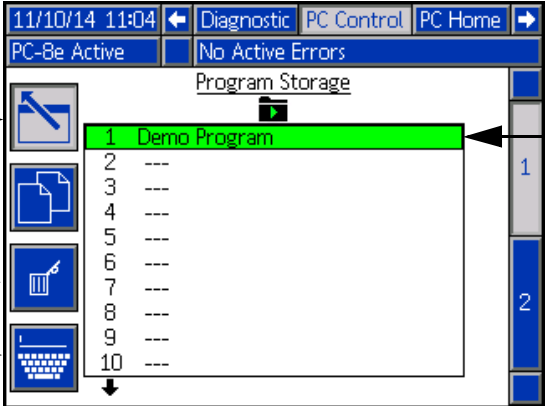
Icon	Name	Description
	Maintenance lock	Press to disable pattern controller (without disabling the InvisiPac pump and heaters)
	Maintenance lock	Press to enable pattern controller

<p>E - Exit screen F - Copy selected G - Erase selected H - Rename selected J - Press  to select active program</p>	
---	--

Gun Purge

1. Purge individual guns .
2. Purge all guns by pressing enter .



NOTE: Only guns with assigned triggers will purge.

NOTE: Guns may only be purged when the system is active or within 5 minutes of the system being active.

A - Press to purge

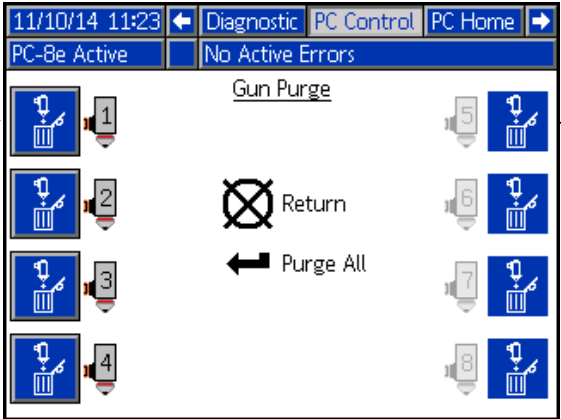
B - Disabled guns will not purge



Icon	Name	Description
	Purge	Purge specific gun
	Enter	Purge all enabled guns
	Return/cancel	Exit screen

Pattern Definition (Screen 2)



1. Enter start point and length of beads.
2. Enable or disable stitching for each bead.
3. Preview this pattern.

NOTE: To clone the pattern from gun A to gun B, navigate to any bead on gun B and press/hold the number key for gun A.

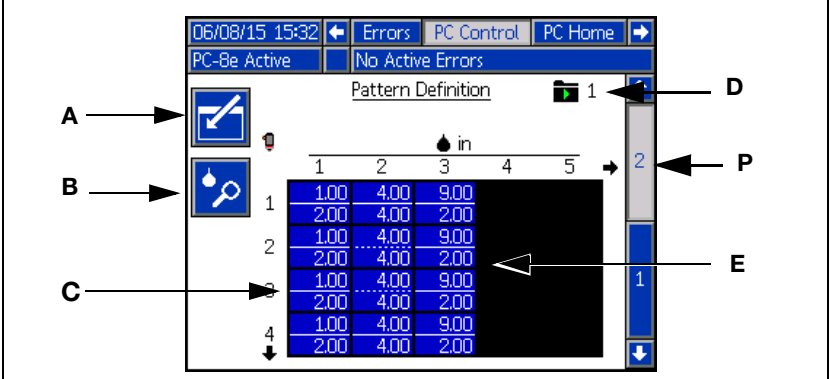
NOTE: Enter the screen and scroll down to see valves 5-8. Add beads and continue to scroll right to access beads 6-24.

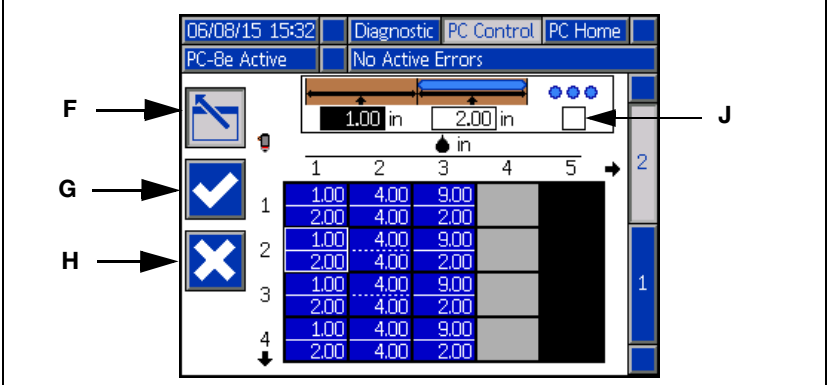
<p>A - Enter screen</p> <p>B - Pattern preview</p> <p>C - Dots = stitched Solid = solid bead</p> <p>D - Current program*</p> <p>E - Start of bead Bead length</p> <p>P - Screen number (Screen 2)</p>	
---	---

<p>F - Exit screen</p> <p>G - Confirm changes</p> <p>H - Cancel changes</p> <p>J - Stitch bead</p>	
--	--

Icon	Name	Description
	Bead offset	Distance from the edge of the product to the start of the bead
	Bead length	Length of the bead
	Stitch bead	Enable or disable stitching of this bead

* Current program indicator signifies that changes to the setting on this page will only affect the current program.

Pattern Preview

Read-only display of bead pattern.

A - Endpoint of last bead

B - Exit preview



 - Gun number

 - Trigger number

11/10/14 12:54
Diagnostic
PC Control
PC Home

PC-8e Active
No Active Errors

Pattern Preview

									
1	1		=====	=====	=====				11.0 in
2	1		=====	=====				11.0 in
3	1		=====	=====				11.0 in
4	1		=====	=====	=====				11.0 in
5	-								0.0 in
6	-								0.0 in
7	-								0.0 in
8	-								0.0 in

 Return

NOTE: Dotted pattern shows stitching. The actual number of stitched bead sis not represented.

NOTE: A red pattern indicates that the gun does not have a trigger selected. See **Event Map**, page 29.

Event Map (Screen 1)

Enter configuration settings for this pattern:



1. Assign trigger to each gun.
2. Enter gun trigger offset.
3. Enter minimum product length (if false trigger pickup is a concern).
4. Enable pattern mirroring.
5. Enter stitch percentage and interval.

<p>A - Enter screen B - Gun number C - Trigger for gun D - Gun trigger offset E - Minimum product length F - Current program* G - Stitch interval H - Stitch savings J - Mirror mode P - Screen number (Screen 1)</p>	
--	--

Icon	Name	Description
	Trigger	Trigger associated with this gun
	Gun trigger offset	The physical distance or time between the trigger and the gun
	Minimum product length	Blocks triggers from activating a second pattern within the minimum product length
	Mirror mode	Mirrors beads from the leading edge of the box to the trailing edge of the box. NOTE: If mirror mode is selected, the gun-to-trigger offset must be at least half the length of the box. See Mirror Mode , page 39.
	Stitch savings	Percentage of glue saved by stitching. Set to 0 to disable stitching. NOTE: Stitching must also be enabled/disabled for each bead. See Stitching , page 37.
	Stitch interval	The distance between the start of each stitch

* Current program indicator signifies that changes to the settings on this page will only affect the current program.

Line Mode (Screen 2)

1. Select mode:
 - a. Time based.
 - b. Distance mode without encoder (uses fixed line speed).
 - c. Distance mode with encoder.
2. For time mode, there are no additional settings.
3. For distance mode without encoder:
 - a. Pass one product by the trigger at normal speed.
4. For distance mode with encoder:
 - a. Verify positive line speed when line is moving forward. If speed is negative, swap A and A' with B and B' wires at the encoder connector on the pattern controller.
 - b. Pass one product by the trigger.
 - c. Adjust encoder pulses per mm  until length of last product  is correct.

NOTE: See trigger setup section if product is not tripping the trigger properly.





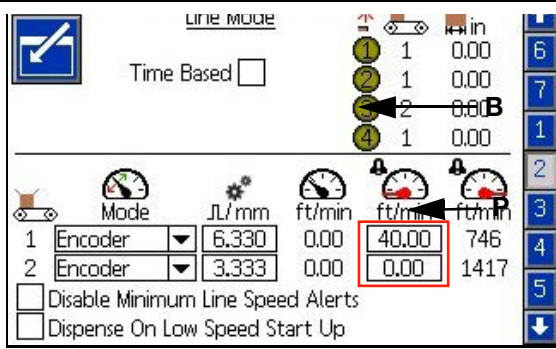

A - Enter screen

B - Last box length





P - Screen number (Screen 2)

A →









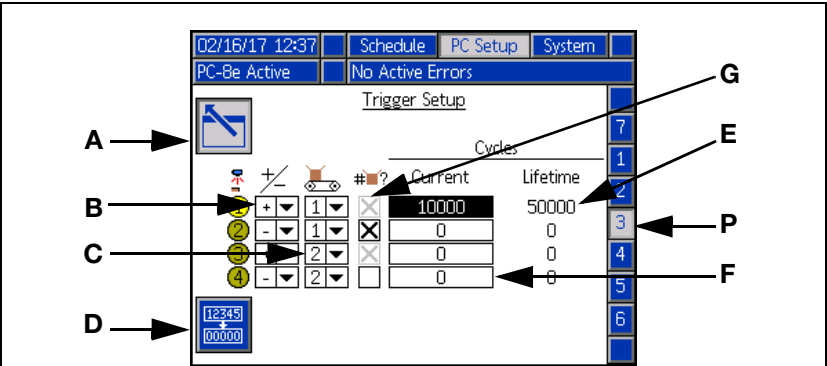



Icon	Name	Description
Time based	Time mode select	In time mode, programs settings are in units of milliseconds
	Line number	Line number for other settings/value sin a row
	Length of last product	Length of the last product seen by a trigger on the line. NOTE: Value adjusts for changes in encoder/speed settings.
	Mode	Select if encoder is to be used
	Encoder pulses per mm	Pulses encoder generates per mm of line travel. NOTE: 1000 ppr encoder, 300 mm wheel = 3.333 pulses/min.
	Low line speed alarm	Outputs will not fire when the line is below this speed. NOTE: A value of 0 disables this alarm.
	High line speed alarm	Read-only: maximum line speed allowed. NOTE: The value is calculated from the encoder pulses per mm.
	Line speed	<ul style="list-style-type: none"> If encoder enabled: view current line speed If encoder disabled: enter fixed line speed

Trigger Setup (Screen 3)

1. Select trigger polarity \pm :
 - a. Trigger  should show bright yellow when product is present and dark yellow for no product.
 - b. If polarity is backwards, use the drop-down  to invert the detection.
2. Select trigger line number  (PC-8e only):
 - a. If product runs past all triggers at the same speed, select line 1.
3. Trigger cycle counters:
 - a. View current and lifetime cycle counts of each trigger.
 - b. Press soft key  to reset current cycle count of selected trigger.

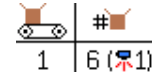
<p>A - Enter screen B - Trigger polarity C - Line 1 or 2 D - Reset selected counter E - Lifetime trigger count F - Resettable trigger count G - Include in product count P - Screen number (Screen 3)</p>	
--	---

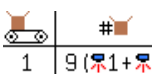
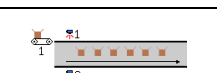
Icon	Name	Description
	Trigger polarity	Toggle polarity to invert state of trigger signal
	Select line	Select which line the trigger is sensing on (PC-8e only)
	Reset counter	Reset trigger cycle count. NOTE: Resetting the first trigger on a given line will reset the product counter on the PC home screen for the given lion.
	Include in product count	Checked - Include trigger cycles in product counter. Unchecked - Do not include trigger cycles in product counter (see table below).

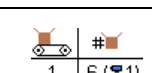
Line Configuration	Diagram	Trigger Setup	PC Home
Single line			
Multi-unit line			
Multi-line			

NOTE: To reset the PC Home product count for each line, reset the current trigger count for the trigger with the disabled (gray) check box.

General Setup (Screen 4)

1. Lock pattern definition (optional) — Protects pattern from accidental changes. Operator must enter a password to change patterns, and copy, delete, or rename programs.

NOTE: This setting will only take effect if run screens are also locked. See **Advanced Screens**, page 35.

2. Invert disable input (optional):

- Used to invert the polarity of the PLC disable input signal. See **PLC Inputs and Outputs Installation**, page 19.
- If selected, disable signal must be pulled high to allow the pattern controller to dispense.
- If not selected (default), disable signal must be pulled high to disable the pattern controller from dispensing.

3. Enable pressure compensation (optional PC-8e only):

- Used to maintain consistent glue output with variable line speed.
- With run-up kit installed, this feature adjusts pump pressure according to the output vs. speed curve. For run-up settings, see **Run Up Control**, page 34.

4. Enable modulated bead (optional, PC-8e only):

- Used to maintain consistent glue output with variable line speed.

- Adjusts output by stitching beads according to the output vs. speed curve.
- When pressure compensation is enabled, modulated bead becomes active below the minimum output percentage.

- When pressure compensation is disabled, modulated bead follows the output vs. speed curve. For run-up settings, see **Run Up Control**, page 42.

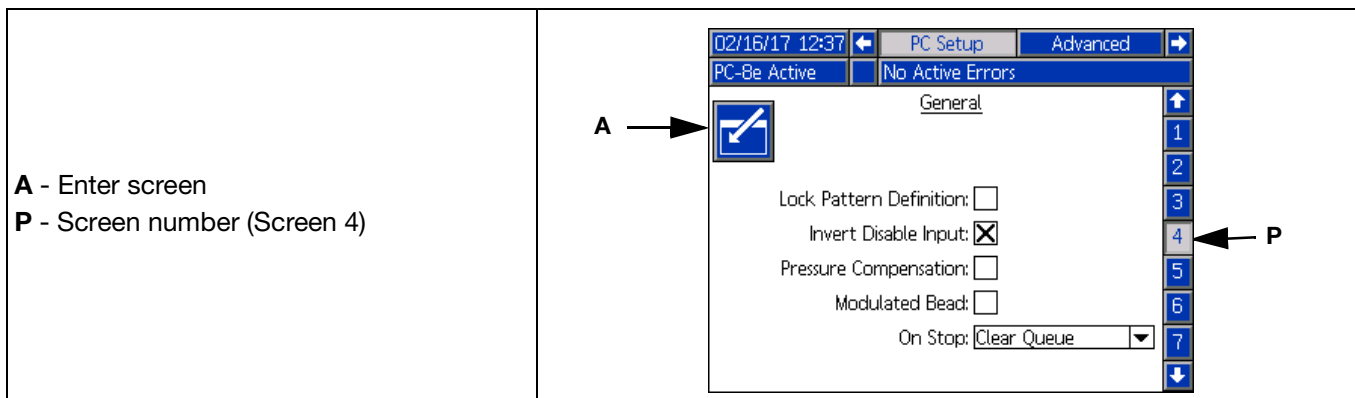

5. On stop (PC-8e only):

- Clear queue (default): Products in process stop when the line stops and do not continue when the line restarts. Products queued between the trigger and gun will also be cleared when the line stops.
- Keep queue: Products in process stop when the line stops and do not continue when the line restarts. Products queued between the trigger and gun are kept when the line stops and processed when the line restarts. Products in the queue can be manually cleared by turning the system off and back on using the power button.
- Pause: Products in process pause when the line stops and continue when the line restarts. Products queued between the trigger and gun are kept when the line stops and processed when the line restarts. Products in process and in the queue can be manually cleared by turning the system off and back on using the power button.



Gun Setup (Screen 5)



1. Gun compensation see **Calibration - Gun Compensation**, page 40:

- Enter gun open compensation 
- Enter gun close compensation 

2. Gun cycle counters:

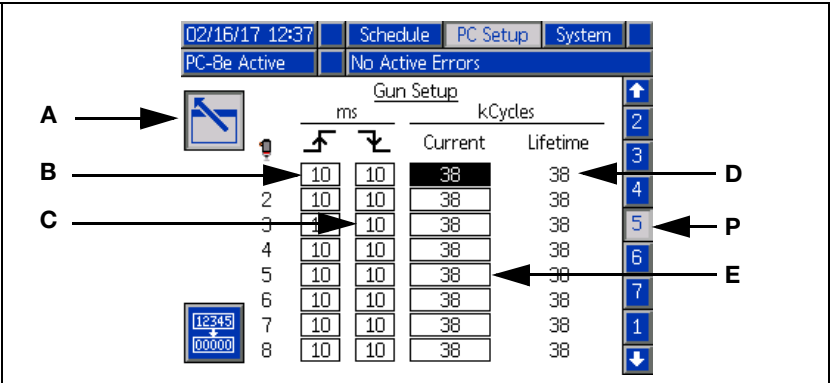
- View current and lifetime cycle counts of each gun,
- Press soft key to reset current cycle counter of selected gun.



<p>A - Enter screen</p> <p>B - Gun open compensation</p> <p>C - Gun close compensation</p> <p>D - Lifetime gun cycles x 1000</p> <p>E - Resettable gun cycles x 1000</p> <p>P - Screen number (Screen 5)</p>	
--	--

Icon	Name	Description
	Open compensation	Mechanical delay between electrical signal to gun and physical opening of gun
	Close compensation	Mechanical delay between electrical signal to gun and physical closing of gun
	Reset counter	Reset gun cycle count

Run Up Control (Screens 6-7, PC-8e only)

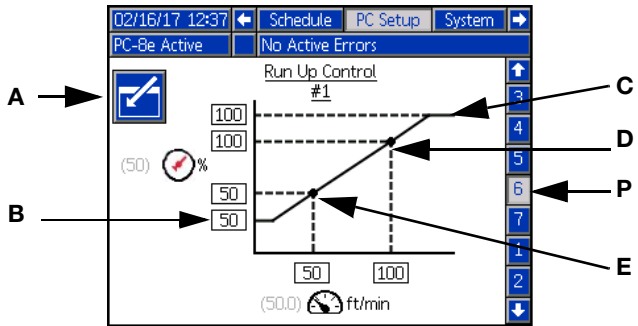
Enter run up output settings. See **Calibration - Run Up Control**, page 34.

<p>A - Enter screen B - Minimum output C - Maximum output D - High calibration point E - Low calibration point P - Screen number (Screen 6)</p>	 <p>The screenshot shows the 'Run Up Control #1' screen. It features a graph with a linear curve. Annotations include: A pointing to the top-left icon; B pointing to the '50' input field for minimum output; C, D, and E pointing to the '100' input fields for maximum output and high/low calibration points respectively; and P pointing to the screen number '6' in the right-hand navigation bar. The graph shows a curve starting at (50, 50) and ending at (100, 100). The x-axis is labeled '(50.0) ft/min' and the y-axis is labeled '(50) %'.</p>
--	---

Icon	Name	Description
	Output pressure percentage	Enter minimum and maximum pressure for run up control. Enter corresponding pressure points for entered line speed points to set run up curve.
	Line speed	Upper and lower line speed points
	Run up pressure to line speed curve	Curve is set by two points which are defined by the user. Upper and lower limits define bounds over which run-up will function linearly.

NOTE: % output refers to the percentage of the run up controller full scale setting, not the percentage of the inlet high pressure.

Advanced Screens

Advanced - Display

General display settings including language, time, and password protection.

12/29/14 08:49 ← Advanced PC Setup →

PC-8e Inactive No Active Errors

Language: English

Date Format: mm/dd/yy

Date: 12 / 29 / 14

Time: 08 : 49

Enter Password: 0000

Screen Saver: 0 minutes

Silent Mode:

Lock Run Screens:

Name	Description
Language	Select the display language
Date format	Select the display format
Date	Enter display date
Time	Enter display time
Password	Enter password to restrict access to Setup screens. NOTE: A value of "0000" does not require a password for access to setup screens.
Screen saver	Enter time-out for the display screen saver. NOTE: A value of "0" disables screen saver.
Silent mode	If selected, disables the display been functionality
Lock run screens	If selected, operators will not be able to change most run screen settings NOTE: In order for this setting to have any effect, a password other than "0000" must be entered above. NOTE: When referring to the run set of screens from the setup screens, the operator will have two minutes to make changes before the screens lock.

Advanced - Units

Select the system units to be used on the display.

12/29/14 08:52 ← Advanced PC Setup →

PC-8e Inactive No Active Errors

Temperature Units: °F

Mass Units: g

Distance Units: in

Name	Description
Temperature	Select the system temperature units (integrated systems only)
Mass units	Select the system mass units (integrated systems only)
Distance units	Select the system distance units. NOTE: This setting applies to all pattern control distance values except when time based mode is selected on <i>PC Setup - Line Mode</i> (distance units become time units of milliseconds).

Advanced - USB Downloads Settings

Select USB download settings.

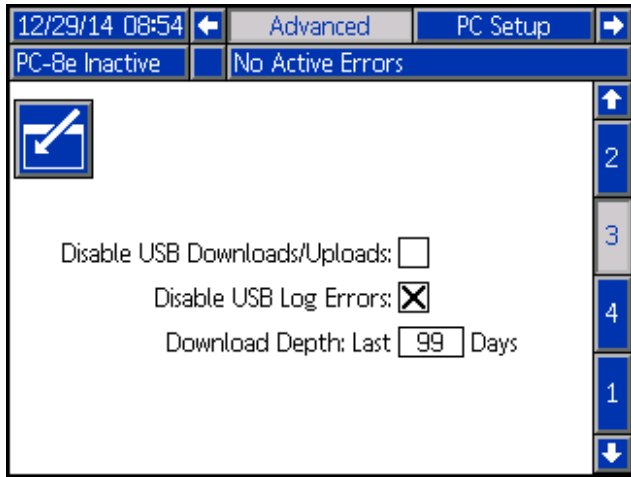

Name	Description
Disable USB down-loads/uploads	Disables USB port from transmitting data to/from a USB drive
Disable USB log errors	Disables USB log advisory errors
Download depth	Sets the length of the data logs to be downloaded (affects the download time)

Advanced - System Software

Read only display of system software.

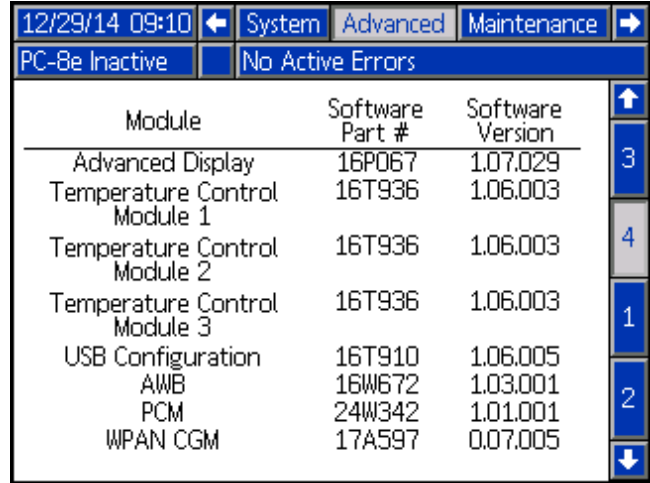

Name	Description
Module	Name of module in system
Software part #	Part number of software installed on module
Software version	Version of software installed on module

NOTE: If software versions or part numbers do not match the expected values, see **Software Update Procedure**, page 50.

Stitching



Stitching is used to reduce adhesive consumption while maintaining bond strength.

Definitions

Sub-Bead -

One dispense cycle of a stitched bead.

Stitch Interval -

The distance between the starts of the adjacent sub-beads.

Stitch Savings -

The percentage of adhesive saved.

Anchor Beads

An anchor bead is a sub-bead placed at the end of the stitched bead that guarantees the stitched bead ends at the same location as the original (non-stitched) bead.

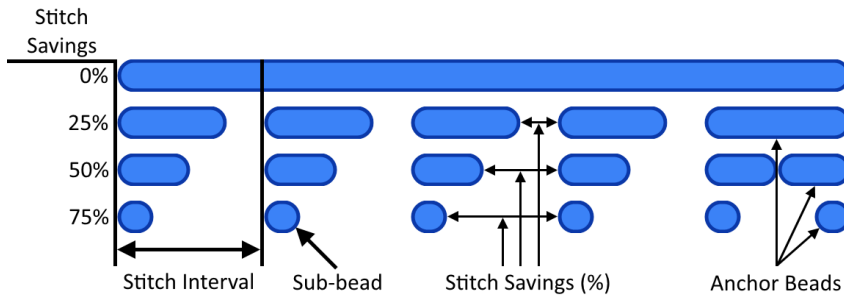

Setup

In order to stitch any bead, perform the following steps:

1. Navigate to **Event Map**, page 29.
2. Enter the desired stitch interval and stitch savings for the desired gun.

NOTE: Stitching can be disabled by setting stitch savings to “0”.

3. Navigate to **Pattern Definition**, page 27.
4. Stitch individual beads by selecting the stitch bead option within each bead entry box.

NOTE: Not all beads for a specific gun must be stitched (some can be stitched while others are solid).

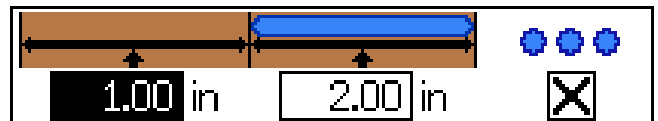

Random Length Bead Mode

For handling products of various lengths with one pattern.

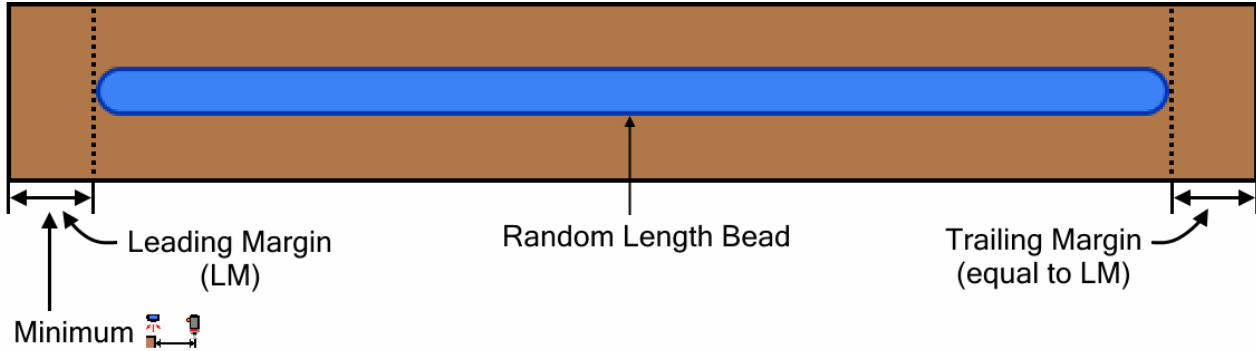

To use random length bead mode, perform the following steps:

1. Navigate to **Event Map**, page 29.
2. Verify the appropriate gun-trigger offset  for the selected gun.

NOTE: Gun-trigger offset must be greater than or equal to the leading margin.

3. Enable mirror mode  for the desired gun.

4. Navigate to **Pattern Definition**, page 27.
5. Enter the leading margin (LM) in the bead 1 offset box.

NOTE: The leading margin is equal to the trailing margin.

6. Enter the length of the longest random bead (LRB) that may be needed in the bead 1 length box.
7. Enable or disable stitching for bead 1.

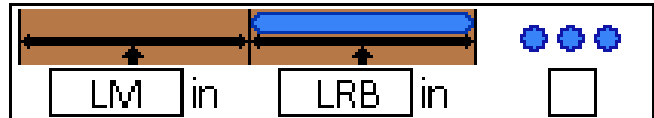

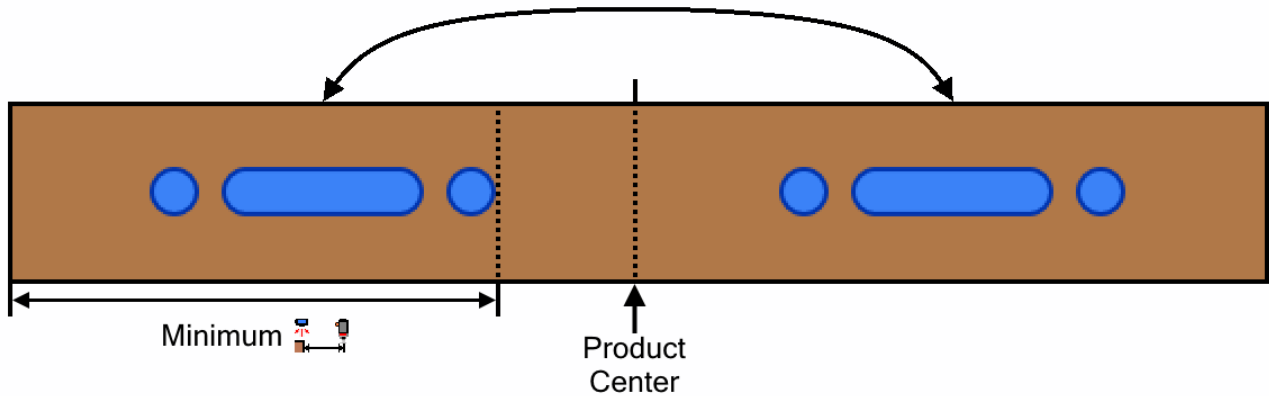

Mirror Mode

For symmetrical patterns, including products with varying lengths.



To use mirror mode, perform the following steps:

1. Navigate to **Event Map**, page 29.
2. Verify gun-trigger offset  for the selected gun is greater than or equal to the end of the final bead (final bead offset + length).
3. Enable mirror mode  for the desired gun.
4. Navigate to **Pattern Definition**, page 27.
5. Enter bead information for the first half of the product.
6. Enable or disable stitching for each bead.

Material Tracking

The material tracking feature can be used on pattern controllers that are connected to an InvisiPac (internal and integrated systems). See the relevant InvisiPac System manual listed in the “Related Manuals” section.

Calibration

Gun Compensation (optional)

For high speed and precision applications.

NOTE: Before entering gun compensation values, make sure the gun-trigger offset has been entered on **Event Map**, page 29.

Gun compensation ensures higher accuracy of bead placement. Begin with *Recommended Values* below and adjust according to *Calibration Routine*.

Recommended Values

GM-100: 5-10 ms









GS-35: 10-20 ms

Unknown, other: 10 ms

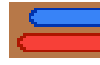
Calibration Routine

1. Navigate to **Gun Setup**, page 33.
2. Dispense desired pattern (program contained within the pattern controller).
3. Measure the error distance between the dispensed pattern on the product and the desired pattern.
4. Adjust open/close compensation values according to the following **Gun Compensation Table** and **Gun Compensation Formula** below.
5. Repeat steps 2-3 until desired pattern achieved.

Gun Compensation Adjustment Guide:

Edge	Leading Edge		Trailing Edge	
Relative Position Desired:  vs. Dispensed:  Adjustment	Lagging 	Leading 	Lagging 	Leading 
	Increase 	Decrease 	Increase 	Decrease 

Gun Compensation Formula:

Determine the gun compensation adjustment amount in milliseconds.

Standard units: Adjustment (ms) = $\frac{5000 \times \text{Measured offset distance (in.)}}{\text{Line speed (ft/min)}}$

Metric units: Adjustment (ms) = $\frac{60 \times \text{Measured offset distance (mm)}}{\text{Line speed (m/min.)}}$

Bead offset distance in inches (mm) as a function of Gun Compensation and Line Speed

Gun Compensation (ms)	Line Speed				
	50 ft/min 15.24 (m/min)	100 ft/min 30.48 (m/min)	200 ft/min 60.96 (m/min)	500 ft/min 154.24 (m/min)	1000 ft/min 304.8 (m/min)
5	0.05 in. 1.27 (mm)	0.1 in. 2.54 (mm)	0.2 in. 5.08 (mm)	0.5 in. 12.7 (mm)	1.0 in. 25.4 (mm)
10	0.1 in. 2.54 (mm)	0.2 in. 5.08 (mm)	0.4 in. 10.16 (mm)	1.0 in. 25.4 (mm)	2.0 in. 50.8 (mm)
20	0.2 in. 5.08 (mm)	0.4 in. 10.16 (mm)	0.8 in. 20.32 (mm)	2.0 in. 50.8 (mm)	4.0 in. 101.6 (mm)

Line Speed

1. Make sure the pattern controller is “inactive” or “locked”. Press the power button to toggle the status (if necessary).

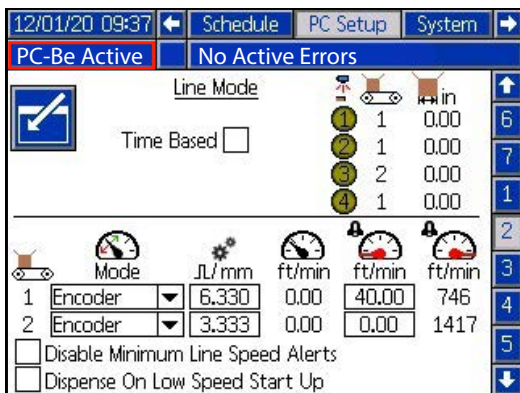

2. Pass a product of known length past the trigger in use.
3. Once the product has passed the trigger, note the value displayed in the *Last Product Length* indicator.

NOTE: The value is the length of the part of the product that passes below the trigger in use, not necessarily the overall length of the product.

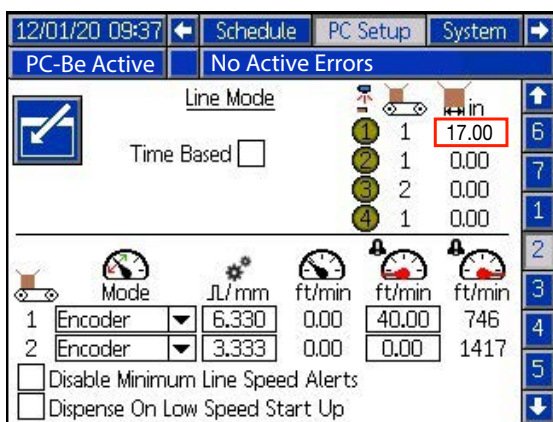

Last Product Length displayed for trigger is 18.00 inches long.

4. Adjust settings:

NOTE: Last product length indicator will update according to the changes made in settings above (step 2 only needs to be performed once).

- a. On encoder systems (PC-8e only), adjust

Encoder Pulses per mm $\frac{\mu L}{mm}$ until the last product length value matches the expected length.

$Actual\ Pulses\ per\ mm = \frac{current\ pulses\ per\ mm \times distance\ observed\ (On\ ADM)}{distance\ measured}$

NOTE: A minimum of 0.25 pulse/mm is required to achieve 1 mm distance precision.

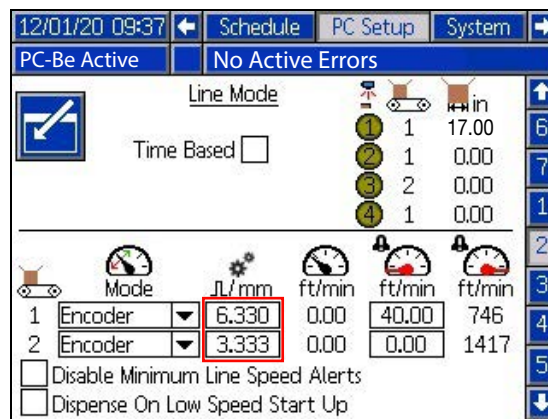

- b. On fixed **line speed systems** (both versions),

adjust *Fixed Line Speed* until the *Last Product Length* value matches the expected length.

$Actual\ Speed = \frac{current\ speed \times distance\ measured}{distance\ observed\ (on\ ADM)}$

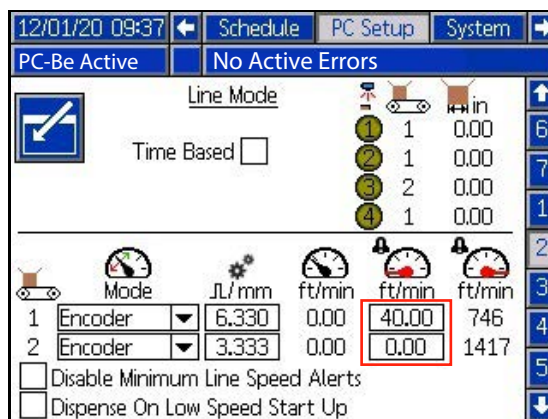

Run Up Control (PC-8e only)

Run up control is used to adjust fluid pressure according to line speed.

NOTE: The Graco run up controller is calibrated for the procedure below. If using a non-Graco run up controller, ensure the controller settings are set to 0 psi offset and 100 psi span, corresponding to 10 V.

1. Change units on regulator from BAR to PSI and the pressure span from 145 to 100 psi (using buttons on front of regulator).

NOTE: This step is only necessary if the display shows 0.00 and not 0.0 when starting.

Units		Pressure Span	
Bar	PSI	145	100
1. Press 4x until BAR is displayed		1. Press 8x until 145 is displayed	
2. Press 1x until PSI is displayed		2. Hold until 100 is displayed	
3. Hold for 5 sec. to save selection		3. Hold for 5 sec. to save selection	

2. Disable the pressure compensation.

NOTE: This is required to determine the settings.

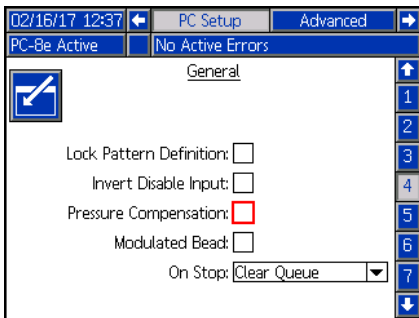

3. Turn the system ON at maximum speed and enter the line speed into the highlighted box below.

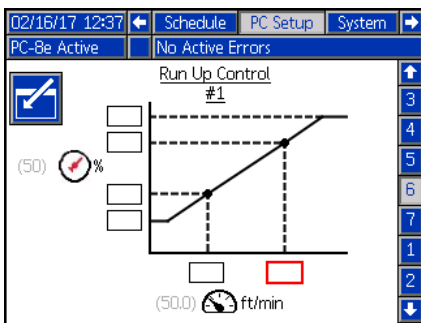

4. Use the dial and gauge on the InvisiPac system to adjust the pump pressure until the desired glue output is achieved.

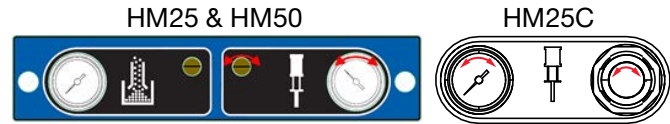

5. Enter the pressure displayed on the run up controller in the highlighted boxes below.

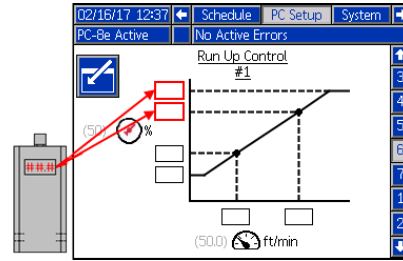

6. Reduce the line speed to the minimum speed and enter the line speed in the highlighted box below.

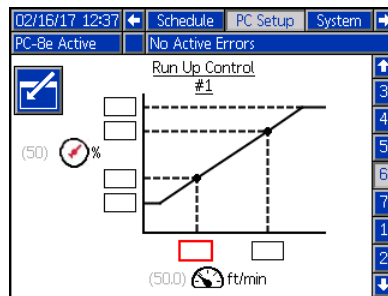

7. Reduce the pump pressure, then use the dial and gauge on the InvisiPac system to adjust the pump pressure until the desired glue output is achieved.

NOTE: InvisiPac pump pressure must be at least 20 psi. Smaller nozzles can be used to increase pump pressure range if needed.

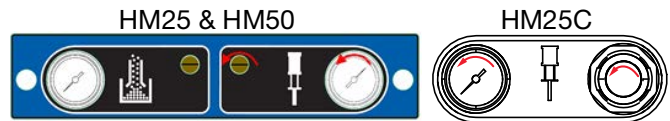

8. Enter the pressure displayed on the regular in the highlighted boxes below

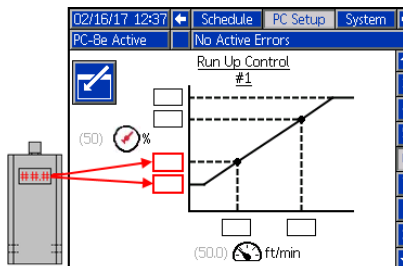

- Return the pressure on the InvisiPac pump pressure gauge to the position from step 3.

NOTE: After turning the pressure back up, it is critical that the pressure knob is not turned down while using run up as it would prevent the run up from working properly.

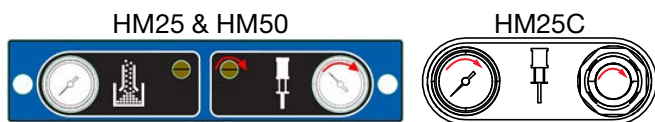

- Enable the pressure compensation.

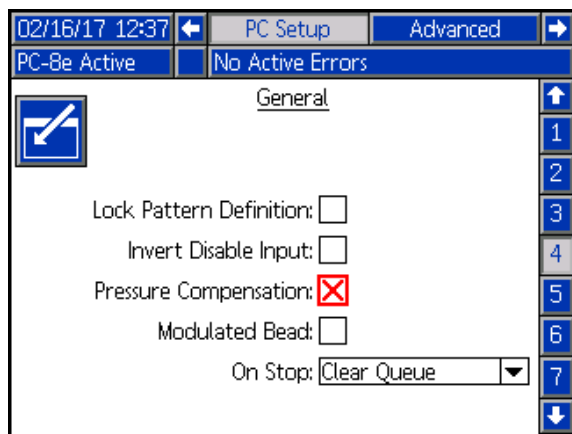

Modulated Bead (PC-8e Only)

Modulated bead is used to adjust fluid output according to line speed without a pressure regulator (using stitching).

NOTE: Modulated beads use the same stitch interval as a normal stitched bead. See **Event Map**, page 29.

- Enable modulated bead.

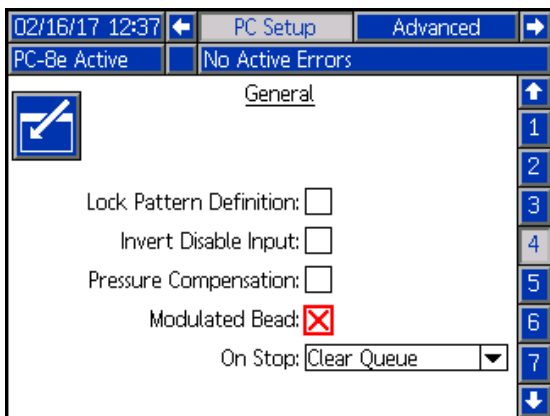

- Enter "100" for both high and output values. **NOTE:** A value of "100" will ensure that a solid bead is dispensed at speeds above maximum line speed.

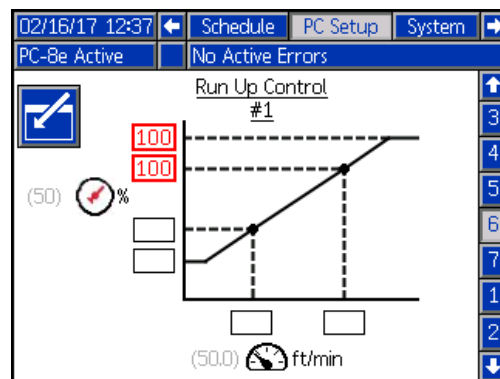

- Enter the minimum and maximum line speed. **NOTE:** The maximum line speed is the speed at which beads will go from solid to stitched.

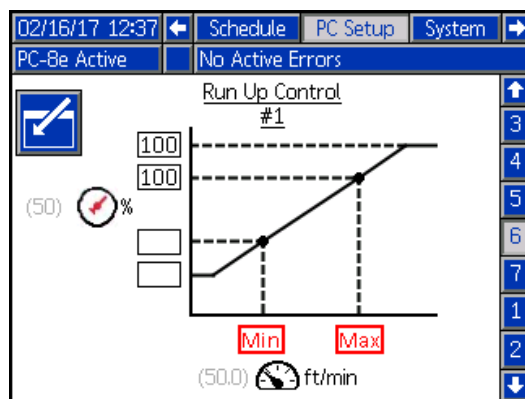

- Enter the low output values.

$$\text{Low Output} = \frac{\text{Minimum Speed}}{\text{Maximum Speed}} * 100$$

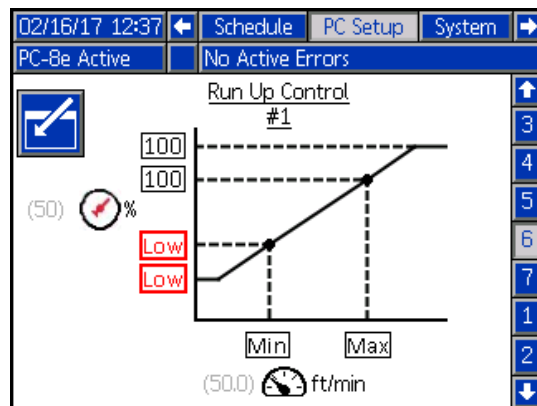

Verification

This section verifies proper installation of the InvisiPac pattern control system. For further assistance, see **Troubleshooting**, page 45.

Valves

1. To verify glue can be dispensed, turn system ON and attempt a purge on each installed valve, then verify the valve is actuated (glue has been dispensed from the appropriate valve).
2. To verify the electrical signal, disconnect the cable from the solenoid and attempt a purge on each installed valve and verify the signal is actuated (via the LED on the valve connector).

Triggers

1. Navigate to **Home**, page 24.
2. Without product in front of the trigger, verify the trigger indicator LED is OFF.
3. With product in front of the trigger, verify the trigger indicator LED is ON.

Encoder

1. Navigate to **Home**, page 24.
2. Verify the line speed displayed in the current line speed  indicator is positive and varies for different line speeds.
3. If the line speed shown does not match the known/expected value, see **Calibration**, page 40.









Run Up Control

1. Navigate to **Home**, page 24.
2. Turn the system ON and wait for the pattern controller to become ACTIVE.

3. Run the line at various speeds and verify the appropriate run up output is displayed on the ADM. Verify the run-up output pressure correctly follows.
4. If the percentage/pressure displayed does not match the expected value, see **Run Up Control**, page 44.

PLC Inputs

1. Navigate to **Home**, page 24.
2. Actuate the PLC input remotely and verify the expected result is indicated in the PLC IO section in the upper right corner of the display.

Action	Icon	Expected Outcome
Turn on line from PLC. NOTE: on integrated systems, use InvisiPac PLC IO to turn on/off InvisiPac. Pattern controller will be in standby until InvisiPac becomes active.		
Turn off line from PLC		
Create safety fault (open door)		
Remove safety fault (close door)		
Select program from PLC		Program #
De-select program from PLC		---
Create an alarm. NOTE: on integrated systems, turn off pattern control box (will generate CAXP alarm).		PLC detects alarm
Clear the alarm. NOTE: on integrated systems, turn on pattern control box.		PLC alarm clears

Troubleshooting



Error Codes

When errors occur, press  to acknowledge each error. After being acknowledged, the error will clear automatically when the condition that caused it is corrected. Active errors scroll on the menu bar.

Alarms shut down the pattern controller and activate the dry contact PLC output. Advisories and deviation are informational only and do not shut the system down.

Alarms (shut the system down)			
Code	Description	Cause	Solution
CAXP	Communication error	ADM unable to communicate with pattern controller	Check for green power light on the pattern controller
			Check communicating cabling
A40P	Over-current	Over-current on trigger and/or run up power supply output (pins identified by "+" on control board)	Check accessory cabling for short circuit.
A4XP	Over-current	Over-current on communication cable output (P3 on control board)	Check ADM CAN cabling for short circuit
			Replace display (ADM)
A4_P	Over-current	Over-current on valve output “_”	Check wiring for short circuit
			Verify valve resistance is higher than 24 ohms
K4_P	High pulse rate	Encoder “_” pulse rate exceeds maximum limit	Select encoder with lower pulse rate
			Reduce line speed or gearing ratio



Advisories and Deviation (do not shut the system down)			
Code	Description	Cause	Solution
V1_P or V2_P	Low voltage	Power supply voltage below 18 VDC	To check for overloaded power supply, measure the voltage with all valves off, and then with all valves on (purging)
			To check for overheated power supply, allow the unit to cool and recheck voltage
			Adjust voltage to 24 V if possible, or replace the power supply
V3_P or V4_P	High voltage	Power supply voltage above 28 VDC	Adjust voltage to 24 V if possible or replace the power supply

Advisories and Deviation (do not shut the system down)			
K1_P	Low line speed	Poor encoder coupling on line “_”	Check to ensure proper coupling between line and encoder. Verify pattern controller is reading appropriate line speed. See Line Mode , page 30.
		Line speed is less than low line speed alarm level on line “_”	Increase line speed or decrease low line speed alarm level. See Line Mode , page 30.
EBTX	PC-8e token removed	Missing or loose PC-8e token	If missing, re-insert PC-8e token. If present, check for loose connection.

Display

Problem	Cause	Solution
Display does not turn on	Select dial on pattern control board set to wrong position	Integrated systems: set to 0 Stand-alone systems: set 1
	Power not turned on	Check for green light on pattern control board and display
	Communication cable disconnected	Verify pattern control board is connected to display
Pattern control screens not present	Selector dial on pattern control board set to wrong position	Integrated systems: set to 0 Stand-alone systems: set to 1
	Software version mismatch	Perform software update process with latest version of software. See Software Update Procedure , page 50.
Run up control screens not present	PC-8e key token not inserted in ADM	Obtain PC-8e key token (comes with PC-8e versions of InvisiPac pattern control system)
Encoder settings not present		

Pattern

Problem	Cause	Solution
No pattern dispensed	Valve not associated with correct trigger (or not assigned to any trigger)	Ensure valve has appropriate trigger selected
	Physical problem with valve	See “No Glue Dispensed” troubleshooting help within <i>Valve</i> section
	Improper stitch settings	<i>Stitch Interval</i>  too short or <i>Stitch Savings</i>  too high
	Wrong/empty programs selected	Ensure proper program is selected on <i>PC Control - Program Storage</i> (see Program Storage , page 25) and <i>PC Control - Pattern Preview</i> (see Pattern Preview , page 28) contains a pattern
	Pattern controller not ACTIVE	Turn on pattern controller. Stand-alone systems will go ACTIVE immediately, whereas Integrated systems will go ACTIVE once the InvisiPac system has gone ACTIVE

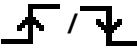
Problem	Cause	Solution
Pattern dispenses too early/late	Improper gun-triggered offset entered	Ensure appropriate <i>Gun-Trigger Offset</i>  is entered on <i>PC Setup - Event Map</i> . See Event Map , page 29.
	Improper valve open/close compensation  entered	Perform calibration routine found in <i>Calibration - Gun Compensation</i> . See Calibration , page 40.
Pattern measurement units are in distance/time	Improper line mode selected	Select appropriate line mode setting on <i>PC Setup - Line Mode</i> . See Line Mode , page 30.

Valve

Problem	Cause	Solution
System reset when guns fire	Current draw from combined valves exceeds power supply rating (150 W)	Ensure current draw is below 6A total between all simultaneously firing valves
No glue dispensed	Solenoid shorted	Ensure proper wiring between solenoid and pattern controller. If no shorts found, consider replacing solenoid.
	Wrong type of valve in use	Pattern controller is only compatible with 24 VDC solenoids (no electric valves or AC solenoids)

Trigger

Problem	Cause	Solution
Trigger always on/off	Sensor is covered/misaligned	Clear any sensor obstruction and verify sensor changes states with object present/absent
	Polarity is backwards	Change <i>Trigger Polarity</i> in <i>PC Setup - Trigger Setup</i> . See Trigger Setup , page 31
	Improper sensor type/installation	See <i>Installation - Trigger Installation</i> for proper sensor selection/installation
Trigger detects multiple times on one box	Trigger not adjusted properly or artifacts on the object being sensed cause false detection	Set <i>Minimum Product Length</i>  in <i>PC Setup - Event Map</i> . See Event Map , page 29.
Trigger sensor turned off (no 24VDC present)	Excessive current drawn from 24VDC supply on	Perform power cycle to reset power to 24 VDC pins
		If error persists, remove components and power cycle until component with excessive current draw is discovered

Encoder

Problem	Cause	Solution
Encoder speed is negative	Encoder travel direction is reversed	Exchange A and A' wires with B and B' wires
		Flip encoder to spin the opposite direction
Encoder speed varies significantly	Encoder coupling is slipping	Improve encoder coupling to line by using different bracket, mounting, coupling, etc.
Encoder reads wrong speed	Encoder is improperly scaled	Perform calibration routine found in <i>Calibration - Line Speed</i> . See Calibration , page 40
	Encoder movement not proportionately scaled to path of product	Remount encoder to ensure ratio between encoder movement and product movement is always a fixed proportion
Encoder does not read line speed	Improper sensor type/installation	See <i>Installation - Encoder Installation</i> for proper sensor selection/installation
	Wrong line mode selected	Select encoder line mode setting on <i>PC Setup - Line Mode</i> . See Line Mode , page 30
Line speed is fixed	Fixed line speed mode selected	Select encoder  line mode setting on <i>PC Setup - Line Mode</i> . See Line Mode , page 30

Run Up

Problem	Cause	Solution
Run up controller reads 0 psi	Integrated systems: InvisiPac systems is INACTIVE	Integrated systems: Turn system ON, run up will be active once system is ACTIVE (pump will turn on)
	Stand-alone systems: PC system is INACTIVE	Stand-alone systems: Turn system ON, run up controller will be active immediately
	No pressure to inlet of run up controller	Ensure pressure is being supplied to the inlet of run up controller (check for valves and shut-offs upstream of controller)
Run up controller produces undesired results	Improper user settings entered	Perform calibration routine found in <i>Calibration - Run Up Control</i> . See Calibration , page 40
	Output pressure desired is greater than inlet pressure	Ensure enough pressure is being supplied to the inlet of the run up controller (standard calibration routine calls for 100 psi)

PLC Inputs and Outputs

Problem	Cause	Solution
Input from PLC not read by pattern controller	Improper input signal from PLC	See PLC Inputs and Outputs Installation (optional) , page 19
	Broken wire	Check wiring between pattern controller and PLC
Output form pattern controller not read by PLC	Improper interface to PLC	See PLC Inputs and Outputs Installation (optional) for specifications and proper installation
	Broken wire	Check wiring between pattern controller and PLC

Software Update Procedure

When software is updated on the ADM the software is then automatically updated on all connected GCA components. A status screen is shown while software is updating to indicate progress.

1. Turn system main power switch OFF.
2. Remove ADM from bracket.
3. Remove token access panel.

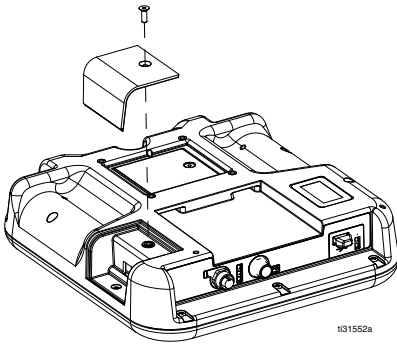

4. Insert and press InvisiPac software upgrade token (part no. 24R324) firmly into slot.

NOTE: There is no preferred orientation of token.

5. Install ADM into bracket.
6. Turn system main power switch ON.

NOTICE

A status is shown while software is updating to indicate progress. To prevent corrupting the software load, do not remove token until the status screen disappears.

NOTE: When the screen turns on, you will see the following screens:

<p>First:</p> <p>Software is checking which GCA modules will take the available updates.</p>	
<p>Second:</p> <p>Status of the update with the approximate time until completion.</p>	
<p>Third:</p> <p>Updates are complete. Icon indicates update success/failure. See the following Icon table.</p>	

Icon	Description
	Update successful
	Update unsuccessful
	Update complete, no changes necessary
	Update was successful/complete but one or more GCA modules did not have a CAN boot-loader so software was not updated on that module

7. Remove token (T).
8. Replace token access panel.
9. Press to continue to the InvisiPac operation screens.

USB Download

The system can store 250,000 entries in its logs and adds a new entry every 15 seconds. This means the system stores 655 hours of system operation data, or 27 days of around-the-clock operation. Once full, the system will overwrite the oldest data.

NOTE: To prevent losing any data, never go more than 27 days without downloading the logs.

Download Procedure

NOTICE

Uploading an edited system configuration file can damage the system. Never put a modified SETTINGS.TXT file in the UPLOAD folder on the flash drive.

1. Insert USB flash drive into USB port.

NOTE: Flash drive must be 8 GB or smaller.

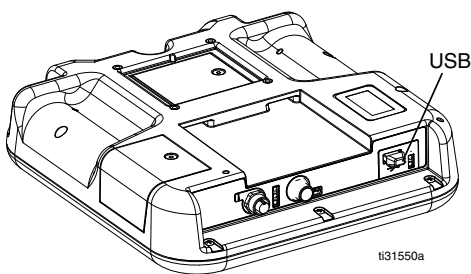

2. The menu bar and USB indicator lights indicate that the USB is downloading files. Wait for USB activity to complete. A pop-up will be present until the transfer is complete if it is not acknowledged.

NOTE: If the pop-up screen does not appear, the flash drive is not compatible with the ADM. Try a different flash drive.

NOTE: The system can log up to 45 MB of additional data per week depending on system operation.

Accessing Files

All files downloaded from the USB are put in a DOWNLOAD folder on the stick drive. For example: "E:\GRACO\12345678\DOWNLOAD\". The 8-digit numeric folder name matches the 8-digit ADM serial number, which is located on the back of the ADM. When downloading from multiple ADMs, there will be one sub-folder in the GRACO folder for each ADM.

The log files should be opened in a spreadsheet program.

NOTE: If emailing the files, zip (compress them to minimize file size).

Upload Procedure

NOTICE

Uploading an edited system configuration file can damage the system. Never put a modified SETTINGS.TXT file in the UPLOAD folder on the flash drive.

Use this procedure to install a system configuration file and/or a custom language file. See **System Settings File** or **System Language File** starting on page 52.

1. If necessary, follow the **System Language File**, page 53, to automatically generate the proper folder structure on the USB flash drive.
2. Insert USB flash drive into USB port of computer.
3. The USB flash drive window automatically opens. If it does not, open USB flash drive from within Windows Explorer.
4. Open Graco folder.
5. Open system folder. If working with more than one system, there will be more than one folder within the Graco folder. Each folder is labeled with the corresponding serial number of the ADM. (The serial number is on the back of the module.)
6. *If installing the system settings file*, place SETTINGS.TXT file into UPLOAD folder.
7. *If installing the custom language file*, place DISP-TEXT.TXT file into UPLOAD folder.
8. Remove USB flash drive from computer.

9. Install USB flash drive into InvisiPac system USB port.
10. The menu bar and USB indicator lights indicate that the USB is uploading files. Wait for USB activity to complete.
11. Remove USB flash drive from USB port.

NOTE: If a custom language file was installed, users can now select the new language from the Language drop-down menu.

NOTE: If the SETTINGS.TXT or DISPTXT.TXT files remain in the UPLOAD folder, they will be uploaded every time the USB drive is inserted into the corresponding ADM. To avoid unintentionally overwriting system settings, delete the files from the UPLOAD folders on the USB drive after the upload is complete.

USB Logs

During operation, InvisiPac stores system and performance related information to memory in the form of log files. InvisiPac maintains the events, data, GCA, black box, and diagnostics logs. Follow the **Download Procedure** to retrieve log files.

Events Log

The event log (1-EVENT.CSV) maintains a record of the last 175,000 events. Each event record in the log file contains the date and time the event occurred, the event type, event code, and event description.

Data Log

The data log (2-DATA.CSV) tracks the setpoint and actual temperatures every 15 seconds. This log can store up to 250,000 lines of data. The system stores 1041 hours of system operation data, or 43 days of around-the-clock operation. Once full, the system will overwrite the oldest data.

NOTE: To prevent losing any data, never go more than 43 days without downloading the logs.

GCA Log

This log (3-GCA.CSV) lists the installed GCA modules and their respective software versions.

Black Box, Diagnostic Logs

These logs (4-BLACKB.CSV, 5-DIAGN.CSV) are designed to provide useful information to Graco when calling for technical assistance.

System Settings File

NOTICE

Uploading an edited system configuration file can damage the system. Never put a modified SETTINGS.TXT file in the UPLOAD folder on the flash drive.

The system configuration settings file name is SETTINGS.TXT and is stored in the DOWNLOAD folder.

A system configuration settings file automatically downloads each time a USB flash drive is inserted. Use this file to back up system settings for future recovery or to easily replicate settings across multiple InvisiPac systems. Refer to the **Upload Procedure**, page 51, for instructions on how to use this file.

It is recommended to retrieve the SETTINGS.TXT file after all system settings are set as desired. Store the file for future use as a backup in case the settings are changed and need to be quickly changed back to the desired setup.

NOTE: System settings may not be compatible between different versions of the InvisiPac software.

System Language File

The system language file name is DISPTXT.TXT and is stored in the DOWNLOAD folder.

A system language file automatically downloads each time a USB flash drive is inserted. If desired, use this file to create a user-defined set of custom language strings to be displayed within the ADM.

The system is able to display the following Unicode characters. For characters outside of this set, the system will display the Unicode replacement character, which appears as a white question mark inside of a black diamond.

- U+0020 - U+007E (Basic Latin)
- U+00A1 - U+00FF (Latin-1 Supplement)
- U+0100 - U+017F (Latin Extended-A)
- U+0386 - U+03CE (Greek)
- U+0400 - U+045F (Cyrillic)

Create Custom Language Strings

The custom language file is a tab-delimited text file that contains two columns. The first column consists of a list of strings in the language selected at the time of download. The second column can be used to enter the custom language strings. If a custom language was previously installed, this column contains the custom strings. Otherwise the second column is blank.

Modify the second column of the custom language file as needed and then follow the **Upload Procedure**, page 51, to install the file.

The format of the custom language file is critical. The following rules must be followed in order for the installation process to succeed.

- The file name must be DISPTXT.TXT.
- The file format must be a tab-delimited text file using Unicode (UTF-16) character representation.
- The file must contain only two columns, with columns separated by a single tab character.
- Do not add or remove rows to the file.
- Do not change the order of the rows.
- Define a custom string for each row in the second column.

Parts

External Models

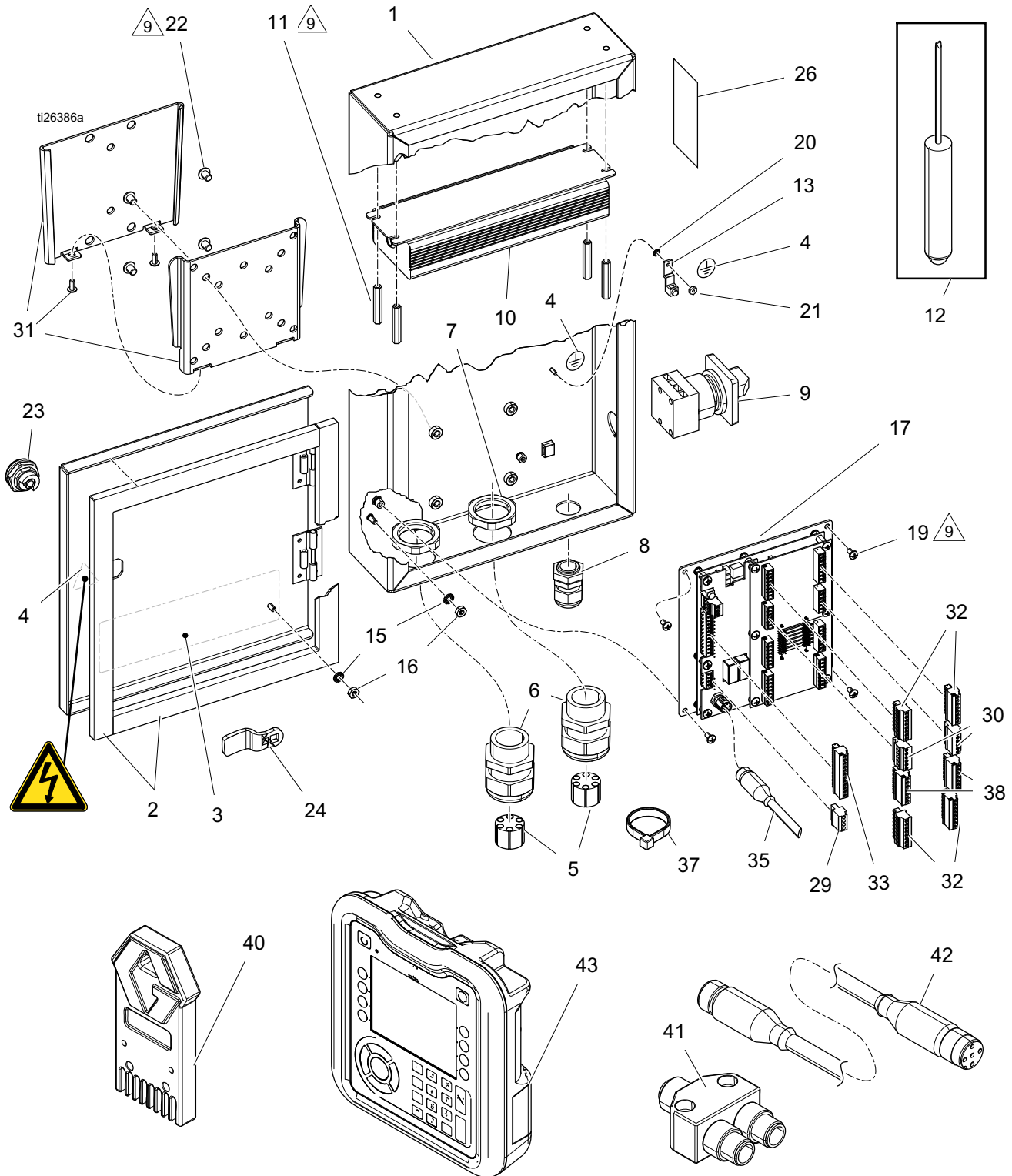

Parts List

Ref.	Part	Description	Qty.	Ref.	Part	Description	Qty.
1	-----	ENCLOSURE, PC, painted	1	29	116772	CONNECTOR, plug, 3.81 mm, 4 position	1
2	-----	FOAM, gasket	2	30	119162	CONNECTOR, plug, 6 position	2
3	-----	LABEL, pattern controller	1	31+	128156	BRACKET, mounting, slide-on	1
4▲	186620	LABEL, symbol ground	1	32*	128147	CONNECTOR, plug, 3.81 mm, 8 position	2
5	127886	GROMMET, pattern controller	2	33	128117	CONNECTOR, plug, 3.81 mm, 12 position	1
6	126881	BUSHING, strain relief	2	35	127768	CABLE, can female, 1.5 m	1
7	126891	NUT, bushing	2	37	-----	TIE, cable, 7.5 in.	1
8	114421	BUSHING, strain relief	1	38	128116	CONNECTOR, plug, 3.81 mm, 7 position (PC-8e only)	2
11	-----	FASTENER, hex, standoff	4	40	24X626	KIT, token, GCA, key, PC-8e (PC-8e only)	1
12	-----	TOOL, screwdriver	1	41	124654	CONNECTOR, splitter (externally integrated models only)	1
13	127939	BLOCK, ground	1	42	121226	CABLE, can, male/female, 0.4 m (externally integrated models only)	1
15	-----	WASHER, lock, ext	2	43	24P860	KIT, replacement, ADM (stand-alone models only)	1
16	-----	NUT, #8-32 hex	2				
17	17E019	MODULE, GCA, pattern control	1				
19	-----	SCREW, machine, ph, 8 x 3/8 in.	4				
20	-----	WASHER, lock	1				
21	-----	NUT, hex	1				
22	-----	WASHER, lock	4				
23	-----	LATCH, tool, secured	1				
24	-----	LATCH, cam	1				
25	-----	SCREW, cap, hex hd	4				
26	-----	BLANK, label kit	1				

+ Qty. 2 for Stand-Alone models

* Qty. 4 for PC-8e

▲ Replacement Danger and Warning labels are available at no cost.

Internal Models (HM25c)

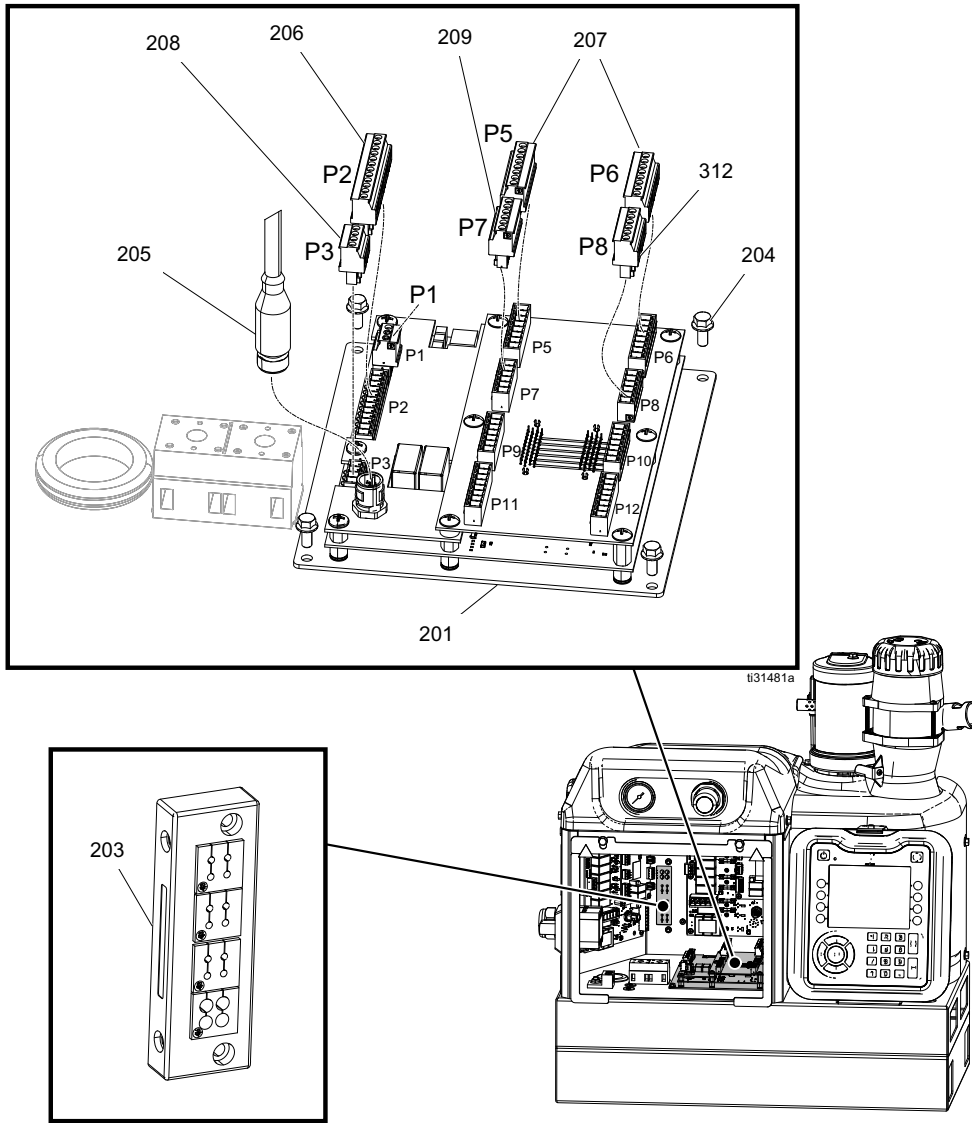

Parts List

Ref.	Part	Description	Qty.
201	17E019	MODULE, GCA, pattern control	1
202	17M504	HARNESS, PC-8 internal	1
203		FRAME, cord grip, 4-position	1
204	125856	SCREW, 8-32, serrated flange	4
205	121000	CABLE, can female/female 0.5m	1
206	128117	CONNECTOR, plug, 3.81mm, 12-position	1
207	128147	CONNECTOR, plug, 3.81mm, 8-position	2
208	129538	CONNECTOR, plug, 3.81mm, 4-position	1
209	129540	CONNECTOR, plug, 3.81mm, 6-position	2

Internal Models (HM25 and HM50)

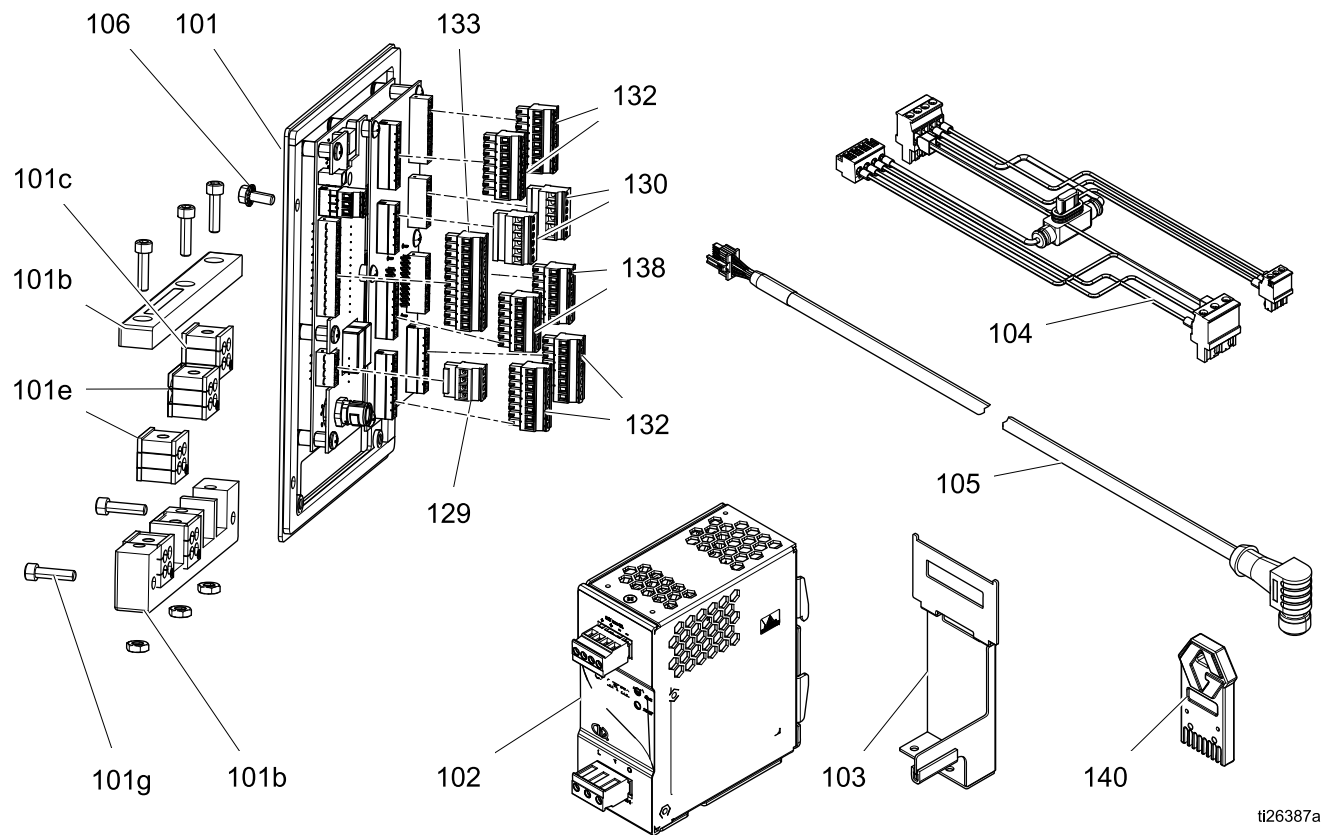

ti26387a

Parts List

Ref.	Part	Description	Qty.	Ref.	Part	Description	Qty.
101	24X521	MODULE, GCA, PC-8e, internal	1	129	116772	CONNECTOR, plug, 3.81 mm, 4 position	1
101b	128176	FRAME, cable grip, 5 position	1	130	119162	CONNECTOR, plug, 3.81 mm, 6 position	2
101c	128177	INSERT, rubber, cable grip 4 x 6 mm	1	132+	128147	CONNECTOR, plug, 3.81 mm, 8 position	2
101d	-----	PIN, 0.250 in.	4	133	128117	CONNECTOR, plug, 3.81 mm, 12 position	1
101e	128178	INSERT, rubber, cable grip, 4 x 3 mm	4	138*	128116	CONNECTOR, plug, 3.81 mm, 7 position	2
101f	-----	PIN, 0.125 in.	16	140*	24X626	KIT, token, GCA, key, PC-8e	1
101g	-----	SCREW, #10-32 x 0.750	2			FUSE, automotive, 4A, 32V, mini (not shown)	1
102	128180	POWER SUPPLY, 120 W	1			TOOL, screwdriver (not shown)	1
103	128443	BRACKET, power supply, PC-8e internal	1			TIE, cable, 7.5 in. (not shown)	8
104	128183	HARNESS, power, PC-8e internal, AWB	1				
105	128182	CABLE, can, female/male	1				
106	125856	SCREW, 8-32, serrated flange	4				







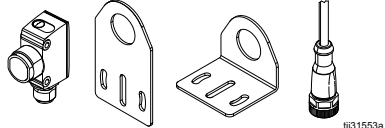
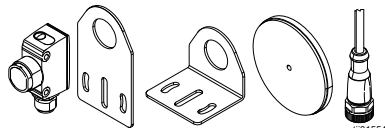
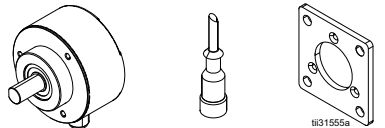
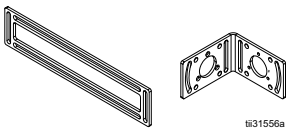
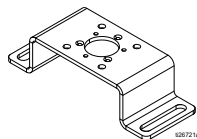
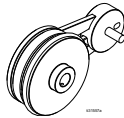
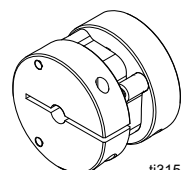
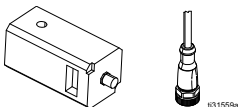

+ Qty. 4 for PC-8e
* PC-8e only

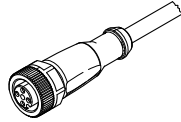
Kits

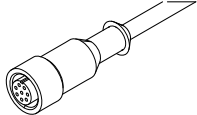
Sensors/Mounting

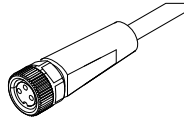
Part	Description	Contents	Image
24X446	KIT, photoeye, diffuse, 18 mm	128073 - SENSOR, photoelectric diffuse 128071 - BRACKET, sensor mount, straight 128070 - BRACKET, sensor mount, angled 24X449 - CABLE, M12, 4-pin, 5.0 m	 ti31553a
24X447	KIT, photoeye, pol ret ref, 18 mm	128072 - SENSOR, photoelectric, polarized 128071 - BRACKET, sensor mount, straight 128070 - BRACKET, sensor mount, angled 128069 - SENSOR, reflector 24X449 - CABLE, M12, 4-pin, 5.0 m	 ti31554a
24X448	KIT, encoder, 1000 PPR, 10 mm	128074 - ENCODER, incremental 24X455 - CABLE, M12, 8-pin, 10.0 m 17E037 - BRACKET, mounting, encoder SCREWS (Qty. 3)	 ti31555a
24X607	KIT, encoder brackets	17E018 - BRACKET, encoder 17E017 - BRACKET, 90 degree, encoder	 ti31556a
128586	KIT, encoder standoff bracket	BRACKET, mounting, standoff, encoder	 i02721a
17F656	KIT, encoder, friction wheel, 300 mm	BRACKET, encoder, right hand	 000000
17F540	KIT, coupler, encoder	10 mm x 6 mm	 ti31558a
17F541		10 mm x 8 mm	
17F542		10 mm x 10 mm	
17F543		10 mm x 12 mm	
17F544		10 mm x 1/8 in.	
17F545		10 mm x 3/16 in.	
17F546		10 mm x 1/4 in.	
17F547		10 mm x 3/8 in.	
17F548		10 mm x 1/2 in.	
17F549		10 mm x 15 mm	
17F550		10 mm x 5/8 in.	
17F551		10 mm x 3/4 in.	
17E020	KIT, run up	127787 - REGULATOR, pressure, V2P 24X449 - CABLE, M12, 4-pin, 5.0 m FITTINGS	 ti31556a

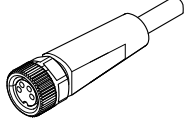
Cables

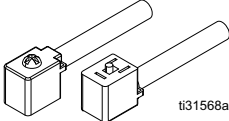
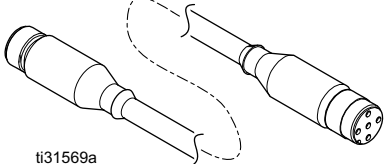
Part	Description	Use with	Image
24X449	KIT, cable, M12, 4-pin, F-L, 5 m	Triggers with M12 connection (12 mm nut) Run-up controller	  ti31561a
24X453	KIT, cable, M12, 4-pin, F-L, 10 m		
24X454	KIT, cable, M12, 8-pin, F-L, 5 m	Encoder	  ti31562a
24X455	KIT, cable, M12, 8-pin, F-L, 10 m		
24X456	KIT, cable, M8, 3-pin, F-L, 5 m	Mini solenoid valve (i.e. GM-100)	  ti31564a
24X457	KIT, cable, M8, 3-pin, F-L, 10 m		
24X458	KIT, cable, M8, 4-pin, F-L, 5 m	Triggers with M8 connection (8 mm nut)	  ti31566a
24X459	KIT, cable, M8, 4-pin, F-L, 10 m		
17F443	KIT, cordset, solenoid, 5 m	Standard solenoid valve (i.e. GS-35)	 ti31568a
17F444	KIT, cordset, solenoid, 10 m		
24R710	KIT, cable, CAN, 5 m	Remote mounting of pattern controller enclosure or ADM	 ti31569a
24R711	KIT, cable, CAN 15 m		
24R712	KIT, cable, CAN 50 m		
128692	CABLE, NDSN encoder	Connects Nordson encoder to the pattern controller	

Repair Parts

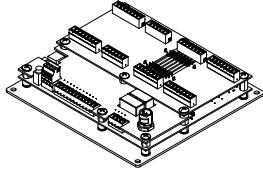
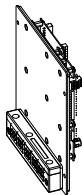
Part	Description	Use with	Image
17E019	KIT, pattern control board	Internal models (HM25c) and external models	 ti31570a
24X521	KIT, internal pattern control board	Internal models (HM25 and HM50)	 i26413a

Upgrades

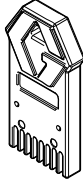
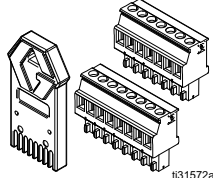
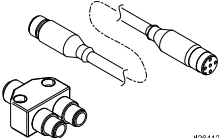
Part	Description	Use with	Image
24R324	KIT, software	TOKEN, GCA, upgrade	 <p>ti31571a</p>
17F712	KIT, PC-8 to PC-8e upgrade	KIT, token, GCA, key, PC-8e CONNECTOR, plug, 3.81 mm, 7 position (x2) CONNECTOR, plug, 3.81 mm, 8 position (x2)	 <p>ti31572a</p>
24Y171	KIT install, internal pattern control Generation 1 systems	HARNESS, secondary power and fuse Connector, splitter CABLE, communications, female/female, 1.0 m CABLE, communications, female/female, 0.5 m	 <p>ti20412a</p>

Wiring Diagrams

NOTE: Refer to manual 3A4938 for HM25c internal pattern controller wiring.

Internal Pattern Controller (HM25 and HM50 Systems with AWB)

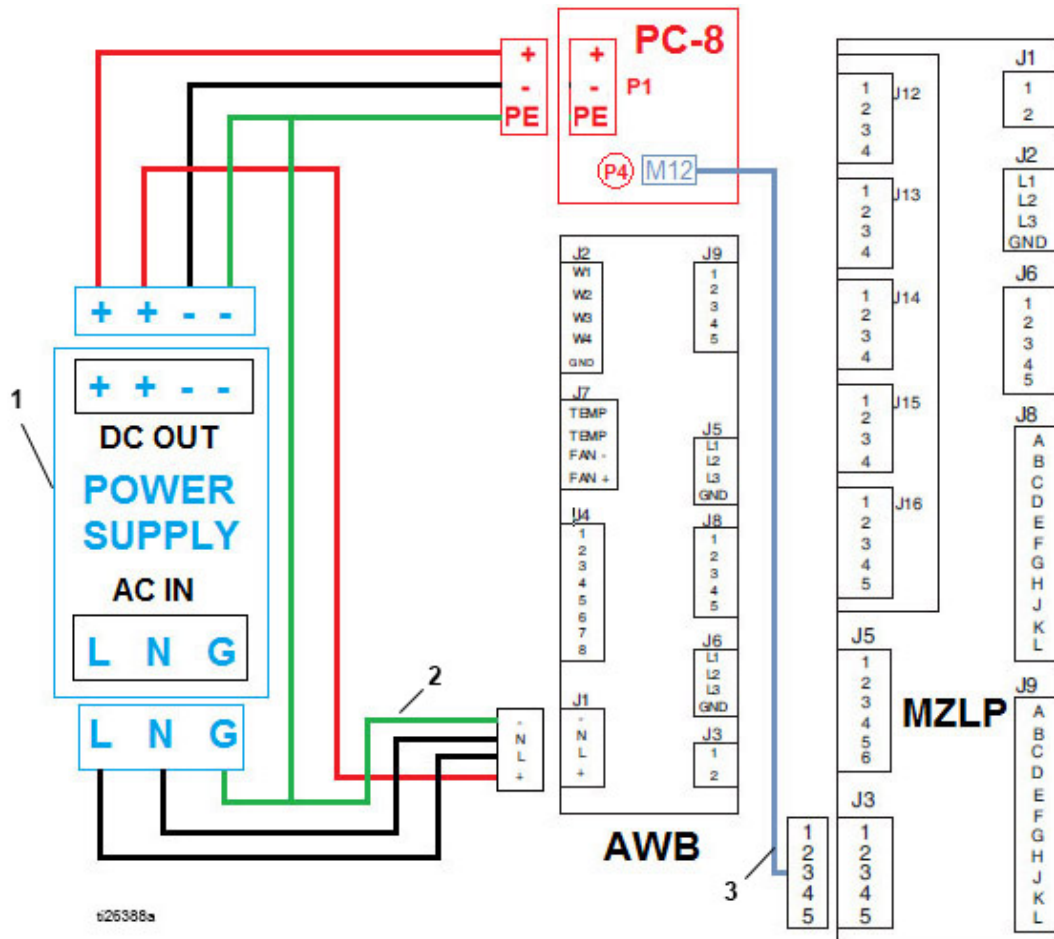

Ref.	Part	Description	Qty.
1	128180	POWER SUPPLY, 120 W	1
2	128183	HARNES, power, PC-8, AWB	1
3	128182	CABLE communication	1

Internal Pattern Controller (HM25 Systems with DIN Rail)

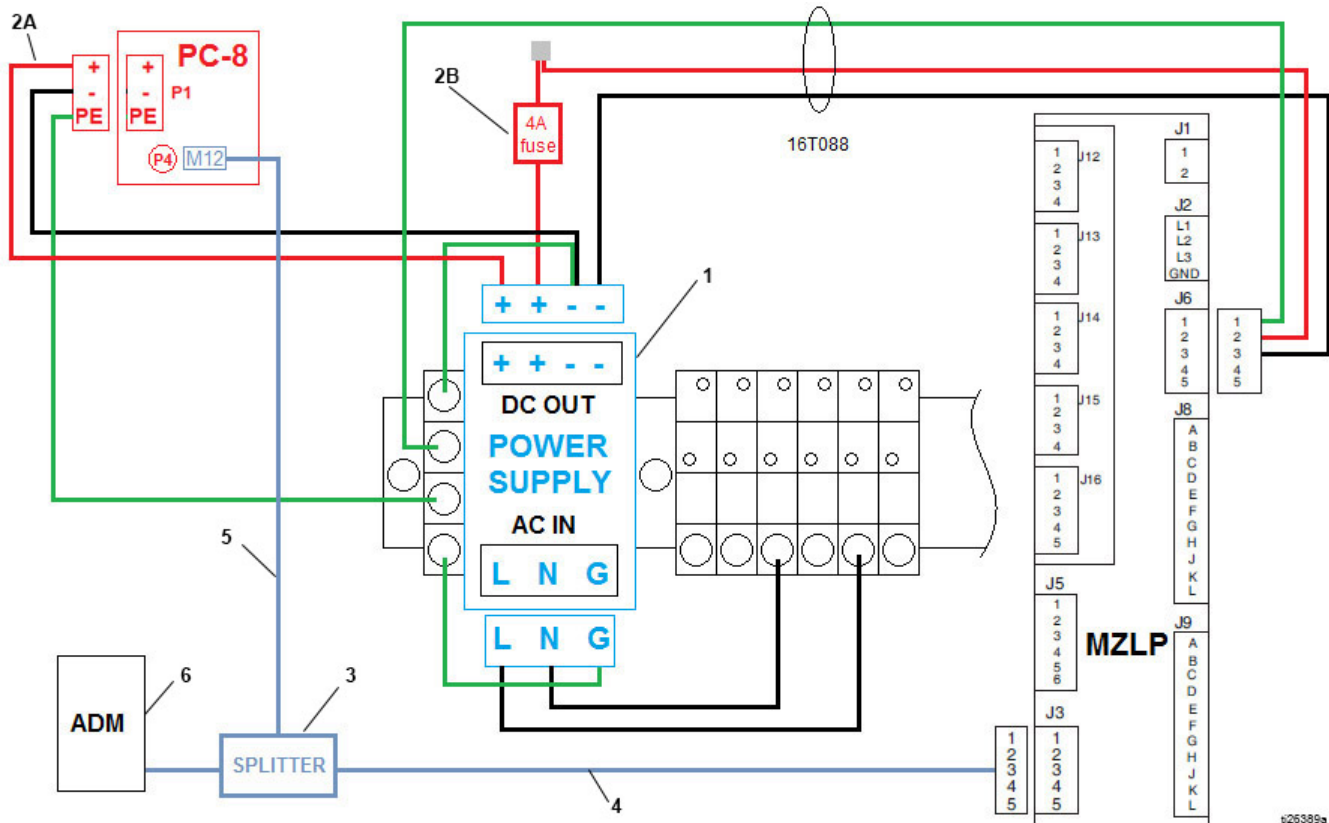

ti26389a

Ref.	Part	Description	Qty.
1	128180	POWER SUPPLY, 120 W	1
2a	128265	HARNESS, power, PC-8, DIN	1
2b	-----	HARNESS, fuse, PC-8, DIN	1
3	128807	CONNECTOR, splitter	1
4	128182	CABLE communication	1
5	125789	CABLE, communication	1
6	127068	CABLE, communication	1

External Models

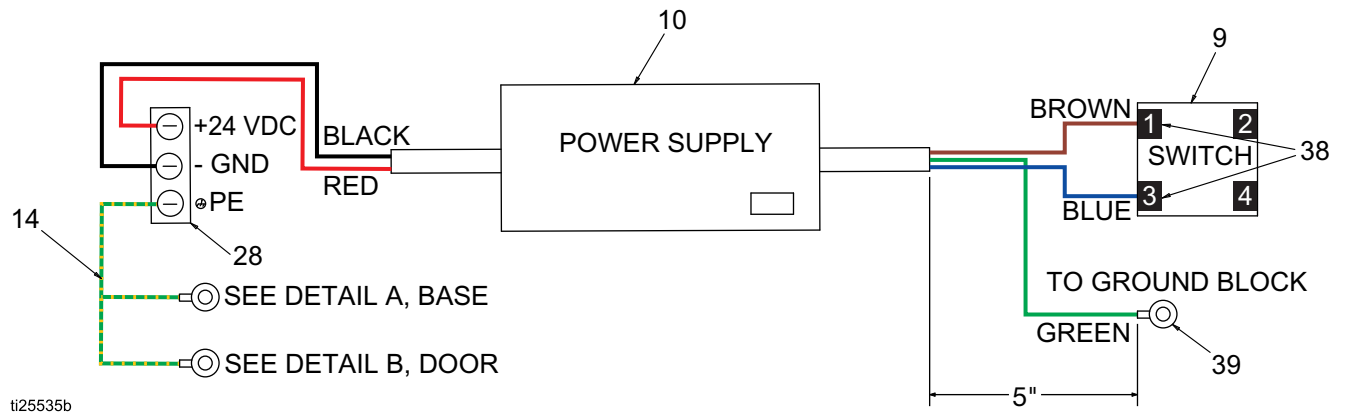

ti25535b

Ref.	Part	Description	Qty.
9	15U423	SWITCH, 2P, 25 A	1
10	127887	POWER SUPPLY, 24 VDC, 6.3 A, 150 W	1
14	-----	HARNESS, ground	1
28	-----	CONNECTOR, plug, 3 position	1
38	-----	TERMINAL, fork, #8	2
39	-----	TERMINAL, fork, #4	1

Dimensioned Drawings

System Enclosure

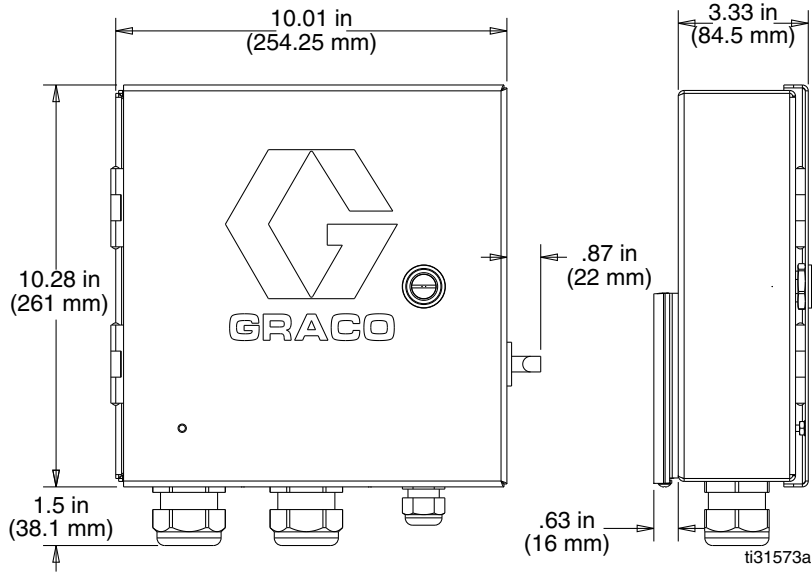

Triggers

128072 - Polarized Retro-Reflective Sensor

128073 - Diffuse Sensor

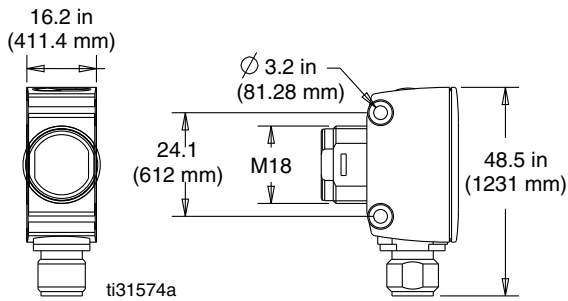

128071 - Mounting Bracket, Straight

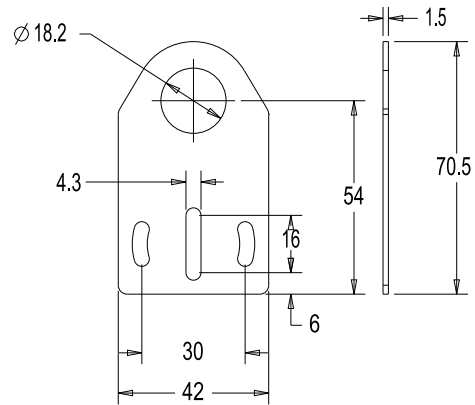

128069 - Reflector

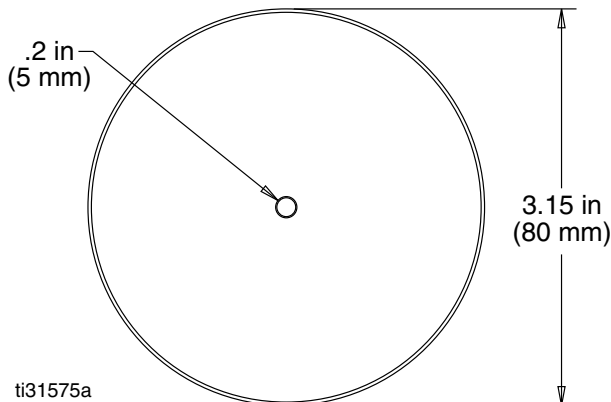

128070 - Mounting Bracket, Right Angle

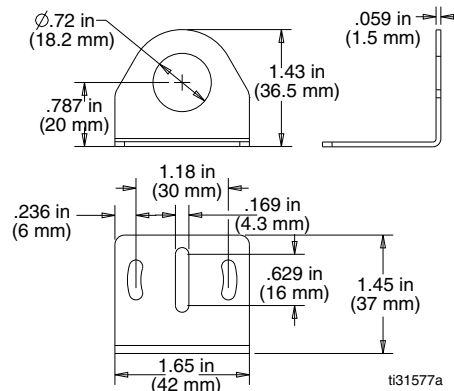

Encoders

128074 - Encoder, Incremental

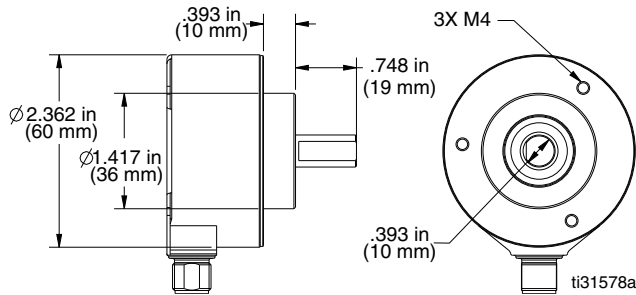

17E037 - Mounting Bracket

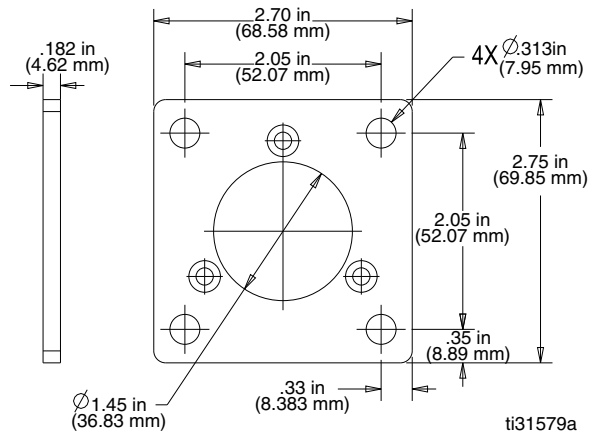

17E017 - Angle Bracket, 90 degree

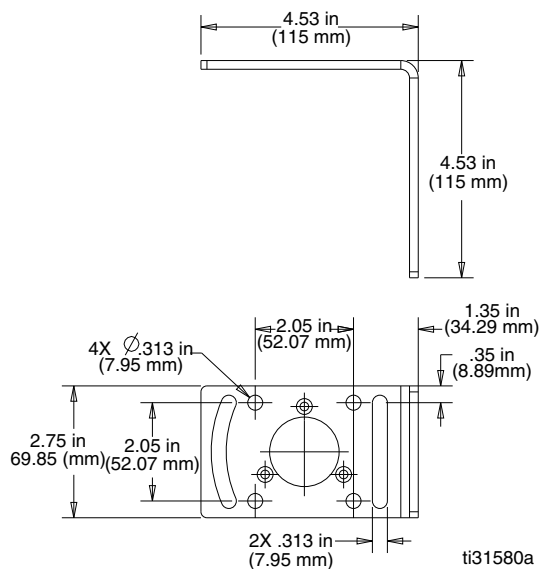

17E018 - Universal Bracket

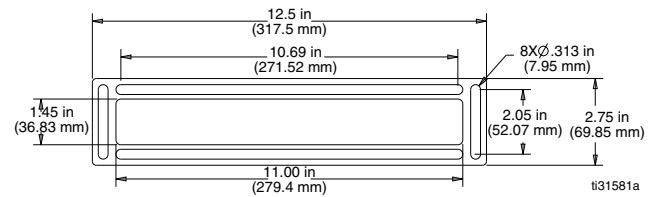

Right Hand Bracket

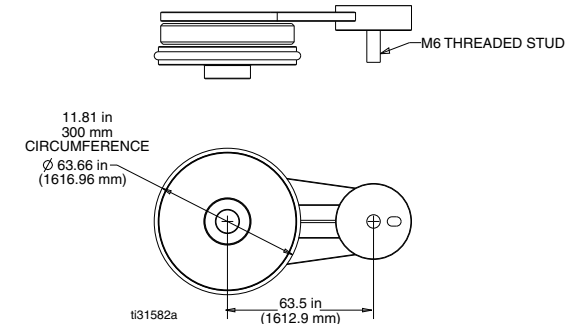

128586 - Standoff Bracket

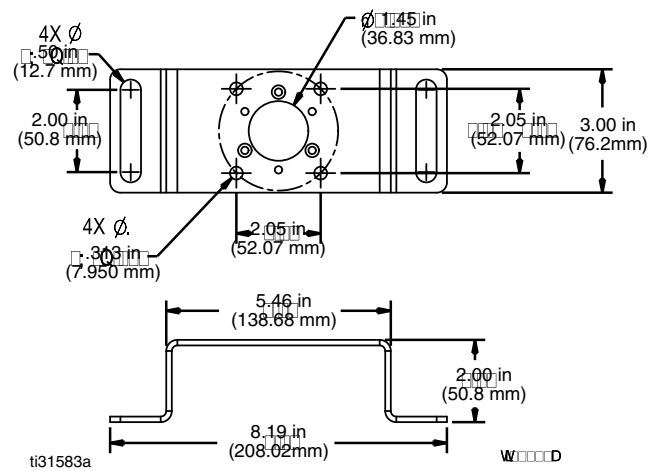

Couplers

Part	L	L1	L2	D	Graco Encoder Shaft	Customer Shaft (Bore)
17F540	1 in. (25.4 mm)	0.374 in. (9.5 mm)	0.25 in. (6.4 mm)	0.984 in. (25.0 mm)	10 mm	6 mm
17F541						8 mm
17F542						10 mm
17F543						12 mm
17F544						1/8 in.
17F545						3/16 in.
17F546						1/4 in.
17F547						3/8 in.
17F548						1/2 in.
17F549	1.17 in. (29.7 mm)	0.394 in. (10.0 mm)	0.38 in. (9.7 mm)	1.457 in. (37.0 mm)	10 mm	15 mm
17F550						5/8 in.
17F551						3/4 in.

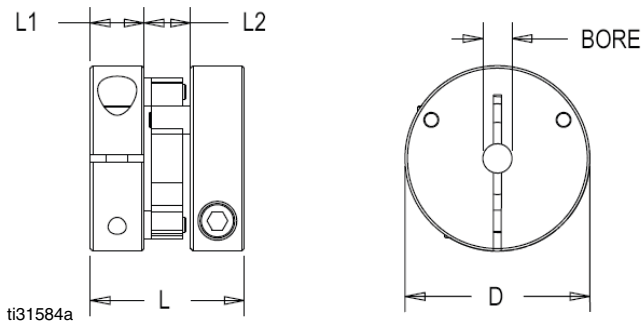

Run Up Controller

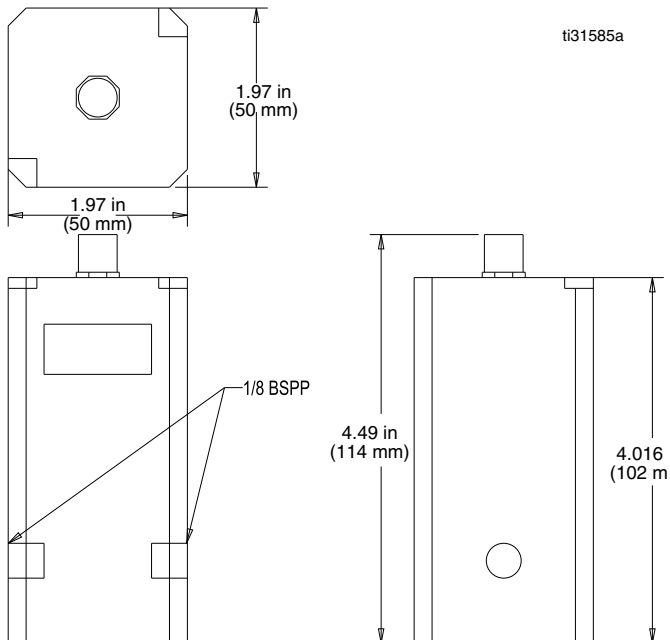

Technical Specifications

InvisiPac Pattern Controller		
Description	Value	Details
Input Power	External models only	100-240 VAC, 50/60 Hz, 2A max
Gun Outputs	8	24 VDC, 1A each, 6A max total
Total Gun Wattage	120 W (internal models - HM25c) 90 W (internal models - HM25 and HM50) 150 W (external models)	-----
Trigger Inputs	4	NPN or PNP or dry contact
Trigger Excitation	24 VDC	-----
Encoder	2 (PC-8e only)	Quadrature differential line driver
Encoder Excitation	15 VDC	-----
Run Up Control	2 (PC-8e only)	I/P (4-20mA) or V/P (0-10V)
Run Up Excitation	24 VDC	-----
PLC Enable/Disable	YES	0-30VDC, min 10 V to assert
PLC Program Select Bit	4	Select up to 15 unique programs
PLA Alarm Output	YES	0-250 VAC (dry contact output)
Integrated Power Supply	YES	24 VDC, 150 W (internal models - HM25c) 24 VDC, 120 W (internal models - HM25 and HM50) 24 VDC, 150 W (external models)
Program Storage	50	-----
Beads Per Output	24	Each bead can be stitched, allowing many more than 24 dots
Distance Accuracy	1 mm, 0.1 in.	-----
Time Accuracy	1 ms	-----
Enclosure Environmental Rating	IP54	Resistant to dust and splashing water
Ambient Temperature	32° - 120°F, 0° - 50°C	-----

Trigger Specifications:

Description	Kit Part	
	24X446	24X447
Sensor type	Diffuse	Retro-reflective
Excitation	10 - 30 VDC	
Sensing range	200 mm	5.0 m
Output type	NPN/PNP	

Encoder Specifications:

Description	Kit Part
	24X448
Excitation	10 - 30 VDC
Pulses per revolution	1000
Output type	5 VDC (TTL/RS422) Differential line driver

Run Up Specifications:

Description	Kit Part
	17E020
Excitation	21.6 - 26.4 VDC
Control voltage	0 - 10 VDC

California Proposition 65

CALIFORNIA RESIDENTS

 **WARNING:** Cancer and reproductive harm – www.P65warnings.ca.gov.

Graco Standard Warranty

Graco warrants all equipment referenced in this document which is manufactured by Graco and bearing its name to be free from defects in material and workmanship on the date of sale to the original purchaser for use. With the exception of any special, extended, or limited warranty published by Graco, Graco will, for a period of eighteen months from the date of sale, repair or replace any part of the equipment determined by Graco to be defective. This warranty applies only when the equipment is installed, operated and maintained in accordance with Graco's written recommendations.

This warranty does not cover, and Graco shall not be liable for general wear and tear, or any malfunction, damage or wear caused by faulty installation, misapplication, abrasion, corrosion, inadequate or improper maintenance, negligence, accident, tampering, or substitution of non-Graco component parts. Nor shall Graco be liable for malfunction, damage or wear caused by the incompatibility of Graco equipment with structures, accessories, equipment or materials not supplied by Graco, or the improper design, manufacture, installation, operation or maintenance of structures, accessories, equipment or materials not supplied by Graco.

This warranty is conditioned upon the prepaid return of the equipment claimed to be defective to an authorized Graco distributor for verification of the claimed defect. If the claimed defect is verified, Graco will repair or replace free of charge any defective parts. The equipment will be returned to the original purchaser transportation prepaid. If inspection of the equipment does not disclose any defect in material or workmanship, repairs will be made at a reasonable charge, which charges may include the costs of parts, labor, and transportation.

THIS WARRANTY IS EXCLUSIVE, AND IS IN LIEU OF ANY OTHER WARRANTIES, EXPRESS OR IMPLIED, INCLUDING BUT NOT LIMITED TO WARRANTY OF MERCHANTABILITY OR WARRANTY OF FITNESS FOR A PARTICULAR PURPOSE.

Graco's sole obligation and buyer's sole remedy for any breach of warranty shall be as set forth above. The buyer agrees that no other remedy (including, but not limited to, incidental or consequential damages for lost profits, lost sales, injury to person or property, or any other incidental or consequential loss) shall be available. Any action for breach of warranty must be brought within two (2) years of the date of sale.

GRACO MAKES NO WARRANTY, AND DISCLAIMS ALL IMPLIED WARRANTIES OF MERCHANTABILITY AND FITNESS FOR A PARTICULAR PURPOSE, IN CONNECTION WITH ACCESSORIES, EQUIPMENT, MATERIALS OR COMPONENTS SOLD BUT NOT MANUFACTURED BY GRACO. These items sold, but not manufactured by Graco (such as electric motors, switches, hose, etc.), are subject to the warranty, if any, of their manufacturer. Graco will provide purchaser with reasonable assistance in making any claim for breach of these warranties.

In no event will Graco be liable for indirect, incidental, special or consequential damages resulting from Graco supplying equipment hereunder, or the furnishing, performance, or use of any products or other goods sold hereto, whether due to a breach of contract, breach of warranty, the negligence of Graco, or otherwise.

FOR GRACO CANADA CUSTOMERS

The Parties acknowledge that they have required that the present document, as well as all documents, notices and legal proceedings entered into, given or instituted pursuant hereto or relating directly or indirectly hereto, be drawn up in English. Les parties reconnaissent avoir convenu que la rédaction du présente document sera en Anglais, ainsi que tous documents, avis et procédures judiciaires exécutés, donnés ou intentés, à la suite de ou en rapport, directement ou indirectement, avec les procédures concernées.

Graco Information

For more information about InvisiPac, visit www.InvisiPac.com or email InvisiPac@graco.com.

TO PLACE AN ORDER, contact your Graco distributor or call to identify the nearest distributor.

Toll Free Phone Number: 1-800-328-0211

All written and visual data contained in this document reflects the latest product information available at the time of publication. Graco reserves the right to make changes at any time without notice.

Original instructions. This manual contains English. MM 334784

Graco Headquarters: Minneapolis

International Offices: Belgium, China, Japan, Korea

GRACO INC. AND SUBSIDIARIES • P.O. BOX 1441 • MINNEAPOLIS MN 55440-1441 • USA
Copyright 2016, Graco Inc. All Graco manufacturing locations are registered to ISO 9001.

www.graco.com
Revision N, September 2024