

DutyMax EH/GH™ 230/300, DH230 HD Hydraulic Sprayers

334606J

EN

For professional use only.

Not approved for use in explosive atmosphere or hazardous locations.

For portable airless spraying of architectural paints and coatings.

3300 psi (22.8 MPa, 228 bar) Maximum Working Pressure

See page 3 for model information, including maximum working pressure and approvals.



Important Safety Instructions

Read all warnings and instructions in this manual and in related manuals.

Be familiar with the controls and the proper usage of the equipment.

Save these instructions.

Related Manuals:

308491	DutyMax DH/GH230 Gun	334654	Pump
309495	DutyMax GH300 Gun	310812	Electric Motor

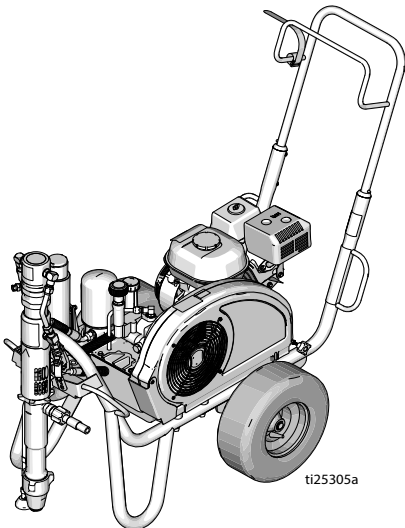

ti25305a

Standard Series

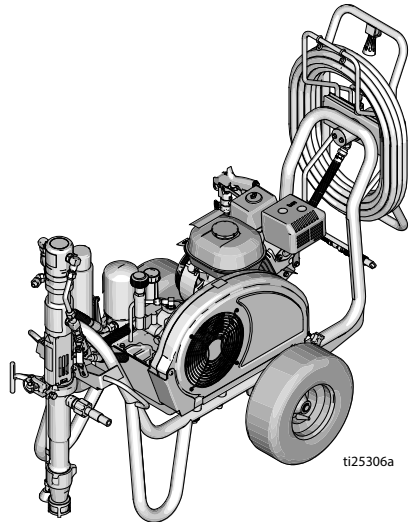

ti25306a

ProContractor Series

Use only genuine Graco replacement parts.

The use of non-Graco replacement parts may void warranty.



Table of Contents

Models	3
Electric Motor Kit Options	3
OEM Kits	3
Warnings	4
Electric Motor Warnings	4
Internal Combustion Engine Warnings	7
Electric Motor/Internal Combustion Engine Warnings	8
Component Identification	11
Standard Models (EH/GH230, 300 HD)	11
ProContractor Models (EH/GH230, 300 HD)	12
ProContractor Model (DH230 HD)	13
Grounding	14
Grounding Procedure for Gas Engine	14
Grounding Procedure for Electric Motor	14
Grounding of Pails	15
Circuit Protection	15
Setup	16
Change Engine or Motor	16
Complete Setup	17
Pressure Relief Procedure	19
Startup (Internal Combustion Models)	20
Startup (Electric Models)	23
How to Spray	25
Switch Tip™ and Guard Assembly	25
Spray	25
Clear Tip Clogs	26
Hose Reel	26
Clean Up	27
Maintenance	29
Troubleshooting	31
Standard Series Pump	33
ProContractor Series Pump	34
DutyMax EH/GH230/300 HD Standard Series Parts	37
DutyMax DH230/EH/GH230/300 HD ProContractor Series	49
Technical Data	64
DutyMax EH230 HD Standard Series	64
DutyMax EH300 HD Standard Series	65
DutyMax GH230 HD Standard Series	66
DutyMax GH300 HD Standard Series	67
DutyMax EH230 HD ProContractor Series	68
DutyMax EH300 HD ProContractor Series	69
DutyMax DH230/GH230 HD ProContractor Series	70
DutyMax GH300 HD ProContractor Series	71
Graco Standard Warranty	75
Graco Information	76

Models

DutyMax EH230 HD				
Model:	Standard	ProContractor		
24W941	✓			
24W942		✓		
DutyMax DH230 HD				
Model:	Standard	ProContractor		
17G592		✓		
DutyMax GH230 HD				
Model:	Standard	ProContractor	120V Motor Kit	120V ETL/CSA/UL Motor Kit
24W943	✓			
24W944	✓		✓	
24W945	✓			✓
24W962		✓		
24W963		✓	✓	
24W964		✓		✓
DutyMax EH300 HD				
Model:	Standard	ProContractor		
24W965	✓			
24W966		✓		
DutyMax GH300 HD				
Model:	Standard	ProContractor		
24W967	✓			
25P353	✓			
24W968		✓		
25P352		✓		
24W967V	✓			
24W968V		✓		

Electric Motor Kit Options

Kit Number	Sprayer Model	Description
248950	DH230/GH230/GH300*	120VAC, 60Hz, 20A, ETL/CSA/UL Approved
248949	DH230/GH230/GH300*	120 VAC, 60Hz, 15A
24M668	DH230/GH230/GH300*	240VAC, 50Hz, 13.4A
24M669	GH300	400VAC, 50Hz, 11.0A

*Performance is limited when using electric motor vs. internal combustion engine

OEM Kits

Kit Number	OEM Model	Description
24W299	GH230/300 OEM	3300 psi (22.8 MPa, 228 bar) Maximum Working Pressure (psi)

Warnings

The following warnings are for the setup, use, grounding, maintenance, and repair of this equipment. The exclamation point symbol alerts you to a general warning and the hazard symbols refer to procedure-specific risks. When these symbols appear in the body of this manual or on warning labels, refer back to these Warnings. Product-specific hazard symbols and warnings not covered in this section may appear throughout the body of this manual where applicable.

Electric Motor Warnings

DANGER



HIGH VOLTAGE ELECTRIC SHOCK HAZARD

This equipment uses high voltage power. Improper contact with high voltage equipment will cause death or serious injury.

- Turn off and disconnect power cord before servicing equipment.
- This equipment must be grounded. Connect only to grounded power source.
- Use only 3-wire extension cords for 240V and single phase models.
- Use only 5-wire extension cords for 400 AC and three phase models.
- Ensure ground prongs are intact on power and extension cords.
- Do not expose to rain. Store indoors.



⚠ WARNING



GROUNDING

This product must be grounded. In the event of an electrical short circuit, grounding reduces the risk of electric shock by providing an escape wire for the electric current. This product is equipped with a cord having a grounding wire with an appropriate grounding plug. The plug must be plugged into an outlet that is properly installed and grounded in accordance with all local codes and ordinances.

- Improper installation of the grounding plug is able to result in a risk of electric shock.
- When repair or replacement of the cord or plug is required, do not connect the grounding wire to either flat blade terminal.
- The wire with insulation having an outer surface that is green with or without yellow stripes is the grounding wire.
- Check with a qualified electrician or serviceman when the grounding instructions are not completely understood, or when in doubt as to whether the product is properly grounded.
- Do not modify the plug provided; if it does not fit the outlet, have the proper outlet installed by a qualified electrician.
- This product is for use on a nominal 120V or 230V circuit and has a grounding plug similar to the plugs illustrated in the figure below.

120V US

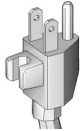

230V



- Only connect the product to an outlet having the same configuration as the plug.
- Do not use an adapter with this product.

Extension Cords:

- Use only a 3-wire extension cord that has a grounding plug and a grounding receptacle that accepts the plug on the product.
- Make sure your extension cord is not damaged. If an extension cord is necessary, use 12 AWG (2.5 mm²) minimum to carry the current that the product draws.
- An undersized cord results in a drop in line voltage and loss of power and overheating.

Warnings

Electric Motor Warnings

WARNING



FIRE AND EXPLOSION HAZARD

Flammable fumes, such as solvent and paint fumes, in **work area** can ignite or explode. To help prevent fire and explosion:



- Do not spray flammable or combustible materials near an open flame or sources of ignition such as cigarettes, motors, and electrical equipment.



- Paint or solvent flowing through the equipment is able to result in static electricity. Static electricity creates a risk of fire or explosion in the presence of paint or solvent fumes. All parts of the spray system, including the pump, hose assembly, spray gun, and objects in and around the spray area shall be properly grounded to protect against static discharge and sparks. Use Graco conductive or grounded high-pressure airless paint sprayer hoses.



- Verify that all containers and collection systems are grounded to prevent static discharge. Do not use pail liners unless they are anti static or conductive.
- Connect to a grounded outlet and use grounded extensions cords. Do not use a 3-to-2 adapter.
- Do not use a paint or a solvent containing halogenated hydrocarbons.
- Do not spray flammable or combustible liquids in a confined area.
- Keep spray area well-ventilated. Keep a good supply of fresh air moving through the area.
- Sprayer generates sparks. Keep pump assembly in a well ventilated area at least 20 feet (6.1 m) from the spray area when spraying, flushing, cleaning, or servicing. Do not spray pump assembly.
- Do not smoke in the spray area or spray where sparks or flame is present.
- Do not operate light switches, engines, or similar spark producing products in the spray area.
- Keep area clean and free of paint or solvent containers, rags, and other flammable materials.
- Know the contents of the paints and solvents being sprayed. Read all Safety Data Sheets (SDS) and container labels provided with the paints and solvents. Follow the paint and solvents manufacturer's safety instructions.
- Fire extinguisher equipment shall be present and working.

Internal Combustion Engine Warnings

WARNING



FIRE AND EXPLOSION HAZARD

Flammable fumes, such as solvent and paint fumes, in **work area** can ignite or explode. To help prevent fire and explosion:



- Use equipment only in well ventilated area.
- Do not fill fuel tank while engine is running or hot; shut off engine and let it cool. Fuel is flammable and can ignite or explode if spilled on hot surface.



- Eliminate all ignition sources; such as pilot lights, cigarettes, portable electric lamps, and plastic drop cloths (potential static arc).



- Keep work area free of debris, including solvent, rags and fuel.
- Do not plug or unplug power cords, or turn power or light switches on or off when flammable fumes are present.
- Ground all equipment in the work area. See **Grounding** instructions.
- Use only grounded hoses.
- Hold gun firmly to side of grounded pail when triggering into pail. Do not use pail liners unless they are anti static or conductive.
- **Stop operation immediately** if static sparking occurs or you feel a shock. Do not use equipment until you identify and correct the problem.
- Keep a working fire extinguisher in the work area.



CARBON MONOXIDE HAZARD

Exhaust contains poisonous carbon monoxide, which is colorless and odorless. Breathing carbon monoxide can cause death.

- Do not operate in an enclosed area.



BURN HAZARD

Equipment surfaces and fluid that is heated can become very hot during operation. To avoid severe burns:

- Do not touch hot fluid or equipment.

Electric Motor/Internal Combustion Engine Warnings

WARNING



SKIN INJECTION HAZARD

High-pressure spray is able to inject toxins into the body and cause serious bodily injury. In the event that injection occurs, **get immediate surgical treatment.**



- Do not aim the gun at, or spray any person or animal.
- Keep hands and other body parts away from the discharge. For example, do not try to stop leaks with any part of the body.



- Always use the nozzle tip guard. Do not spray without nozzle tip guard in place.



- Use Graco nozzle tips.

- Use caution when cleaning and changing nozzle tips. In the case where the nozzle tip clogs while spraying, follow the **Pressure Relief Procedure** for turning off the unit and relieving the pressure before removing the nozzle tip to clean.



- Equipment maintains pressure after power is shut off. Do not leave the equipment energized or under pressure while unattended. Follow the **Pressure Relief Procedure** when the equipment is unattended or not in use, and before servicing, cleaning, or removing parts.
- Check hoses and parts for signs of damage. Replace any damaged hoses or parts.
- This system is capable of producing 3300 psi (22.8 MPa, 228 bar). Use Graco replacement parts or accessories that are rated a minimum of 3300 psi (22.8 MPa, 228 bar).
- Always engage the trigger lock when not spraying. Verify the trigger lock is functioning properly.
- Verify that all connections are secure before operating the unit.
- Know how to stop the unit and bleed pressure quickly. Be thoroughly familiar with the controls.

WARNING



EQUIPMENT MISUSE HAZARD

Misuse can cause death or serious injury.

- Always wear appropriate gloves, eye protection, and a respirator or mask when painting.
- Do not operate or spray near children. Keep children away from equipment at all times.
- Do not overreach or stand on an unstable support. Keep effective footing and balance at all times.
- Stay alert and watch what you are doing.
- Do not operate the unit when fatigued or under the influence of drugs or alcohol.
- Do not kink or over-bend the hose.
- Do not expose the hose to temperatures or to pressures in excess of those specified by Graco.
- Do not use the hose as a strength member to pull or lift the equipment.
- Do not spray with a hose shorter than 25 feet.
- Do not alter or modify equipment. Alterations or modifications may void agency approvals and create safety hazards.
- Make sure all equipment is rated and approved for the environment in which you are using it.



PRESSURIZED ALUMINUM PARTS HAZARD

Use of fluids that are incompatible with aluminum in pressurized equipment can cause serious chemical reaction and equipment rupture. Failure to follow this warning can result in death, serious injury, or property damage.

- Do not use 1,1,1-trichloroethane, methylene chloride, other halogenated hydrocarbon solvents or fluids containing such solvents.
- Do not use chlorine bleach.
- Many other fluids may contain chemicals that can react with aluminum. Contact your material supplier for compatibility.



MOVING PARTS HAZARD

Moving parts can pinch, cut or amputate fingers and other body parts.

- Keep clear of moving parts.
- Do not operate equipment with protective guards or covers removed.
- Pressurized equipment can start without warning. Before checking, moving, or servicing equipment, follow the **Pressure Relief Procedure** and disconnect all power sources.

WARNING



ENTANGLEMENT HAZARD

Rotating parts can cause serious injury.

- Keep clear of moving parts.
- Do not operate equipment with protective guards or covers removed.
- Do not wear loose clothing, jewelry or long hair while operating equipment.
- Equipment can start without warning. Before checking, moving, or servicing equipment, follow the **Pressure Relief Procedure** and disconnect all power sources.



TOXIC FLUID OR FUMES HAZARD

Toxic fluids or fumes can cause serious injury or death if splashed in the eyes or on skin, inhaled, or swallowed.

- Read SDSs to know the specific hazards of the fluids you are using.
- Store hazardous fluid in approved containers, and dispose of it according to applicable guidelines.



RECOIL HAZARD

Gun may recoil when triggered. If you are not standing securely, you could fall and be seriously injured.



PERSONAL PROTECTIVE EQUIPMENT

Wear appropriate protective equipment when in the work area to help prevent serious injury, including eye injury, hearing loss, inhalation of toxic fumes, and burns. Protective equipment includes but is not limited to:

- Protective eyewear, and hearing protection.
- Respirators, protective clothing, and gloves as recommended by the fluid and solvent manufacturer.

CALIFORNIA PROPOSITION 65

The engine exhaust from this product contains a chemical known to the State of California to cause cancer, birth defects or other reproductive harm.

This product contains a chemical known to the State of California to cause cancer, birth defects or other reproductive harm. Wash hands after handling.

Component Identification

Standard Models (EH/GH230, 300 HD)

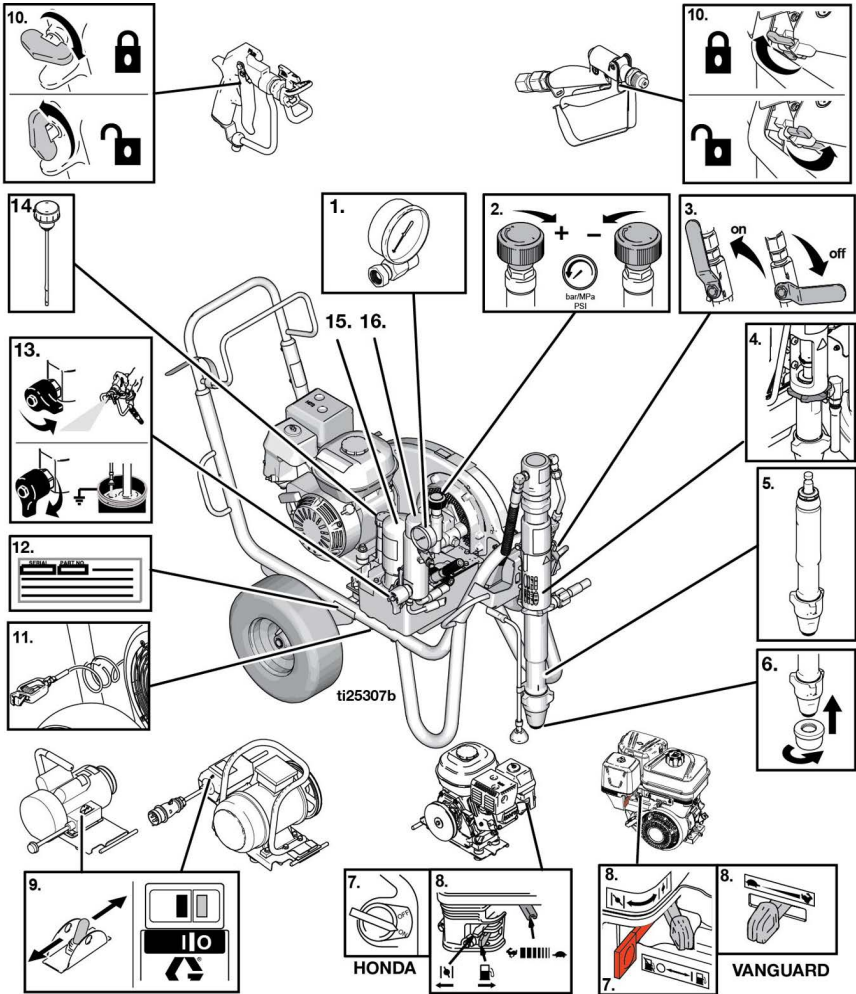

1	Pressure Gauge
2	Pressure Control
3	Hydraulic Pump Valve
4	Threaded Pump Connection
5	Displacement Pump
6	Inlet Strainer
7	Engine On/Off Switch
8	Engine Controls

9	Electric Motor On/Off Switch
10	Gun Trigger Lock
11	Grounding Clamp
12	Serial Number Tag
13	Prime/Drain Valve
14	Hydraulic Oil Cap / Dipstick
15	Hydraulic Oil Filter
16	Paint Filter

Component Identification

ProContractor Models (EH/GH230, 300 HD)

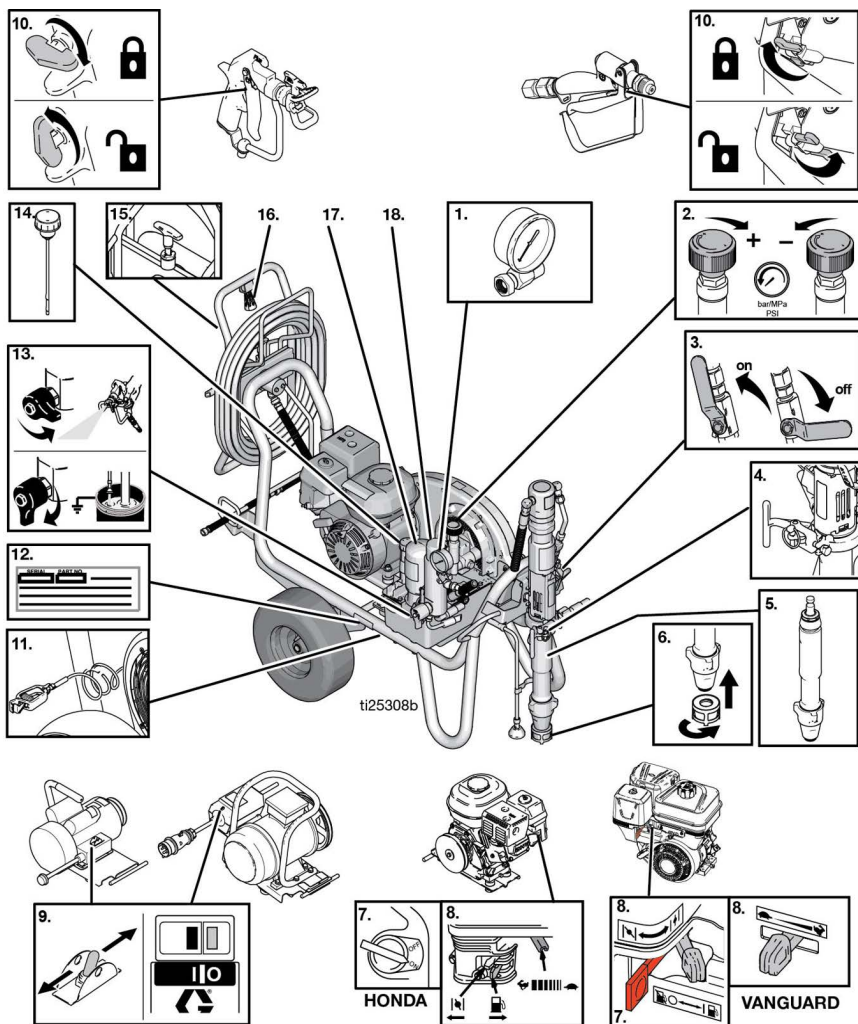

1	Pressure Gauge
2	Pressure Control
3	Hydraulic Pump Valve
4	ProConnect
5	Displacement Pump
6	Inlet Strainer
7	Engine On/Off Switch
8	Engine Controls
9	Electric Motor On/Off Switch

10	Gun Trigger Lock
11	Grounding Clamp
12	Serial Number Tag
13	Prime/Drain Valve
14	Hydraulic Oil Cap / Dipstick
15	Hose Reel Lock
16	Hose Reel Handle
17	Hydraulic Oil Filter
18	Paint Filter

Component Identification

ProContractor Model (DH230 HD)

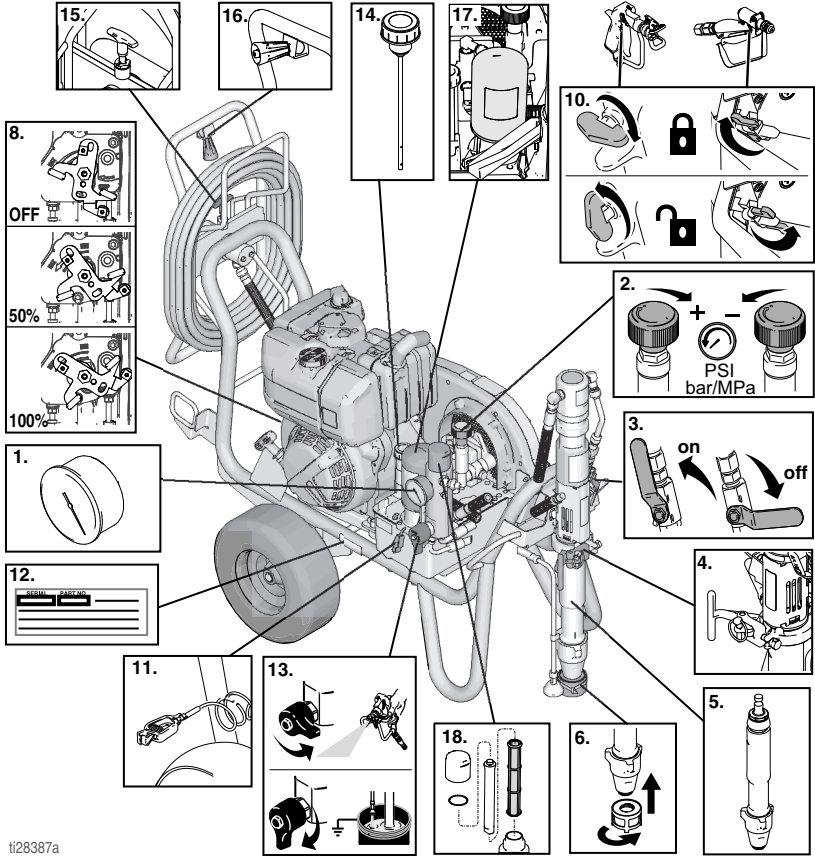



ti28387a

1	Pressure Gauge
2	Pressure Control
3	Hydraulic Pump Valve
4	ProConnect
5	Displacement Pump
6	Inlet Strainer
8	Engine Controls
10	Gun Trigger Lock

11	Grounding Clamp
12	Serial Number Tag
13	Prime/Drain Valve
14	Hydraulic Oil Cap / Dipstick
15	Hose Reel Lock
16	Hose Reel Handle
17	Hydraulic Oil Filter
18	Paint Filter

Grounding

Grounding Procedure for Gas Engine

				
<p>The equipment must be grounded to reduce the risk of static sparking. Static sparking can cause fumes to ignite or explode. Grounding provides an escape wire for the electric current.</p>				

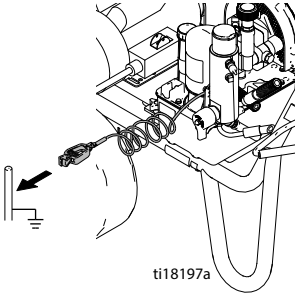

To ground sprayer: Attach sprayer grounding clamp to earth ground.

Air and fluid hoses: Use only electrically conductive hoses with a maximum of 500ft. (150 m) combined hose length to ensure grounding continuity. Check electrical resistance of hoses. If total resistance to ground exceeds 29 megaohms, replace hose immediately.

Spray gun: Ground through connection to a properly grounded fluid hose and pump.

Power Requirements

- 110-120V units require 100-120 VAC, 50/60 Hz, 15A, 1 phase.
- 230V units require 230 VAC, 50/60 Hz, 16A, 1 phase
- 380-400V units require 400 VAC, 50 Hz, 16A, 3 phase, 3P+N+E, 6H power

Grounding Procedure for Electric Motor

 DANGER
HIGH VOLTAGE ELECTRIC SHOCK HAZARD
<p>This equipment uses high voltage power. Improper contact with high voltage equipment will cause death or serious injury.</p> <ul style="list-style-type: none">• Turn off and disconnect power cord before servicing equipment.• This equipment must be grounded. Connect only to grounded power source.• Use only 3-wire extension cords for 240V and single phase models• Use only 5-wire extension cords for 400 AC and three phase models.• Ensure ground prongs are intact on power and extension cords.• Do not expose to rain. Store indoors.• All electrical wiring must be done by a qualified electrician and comply with all local codes and regulations.

The sprayer cord includes a grounding wire with an appropriate grounding contact.

If using the electric motor, plug must be plugged into an actual outlet that is properly installed and grounded in accordance with all local codes and ordinances.

Do not modify the plug provided; if it does not fit the outlet, have the proper outlet installed by a qualified electrician.

connection

- To operate the EH300DI (24W965) sprayer, the generator needs to be sized for 15 kW output (minimum).

Extension Cords

Use an extension cord with an undamaged ground contact. If an extension cord is necessary, use a 3-wire, 12 AWG (2.5 mm²) minimum.

NOTE: Smaller gauge or longer extension cords may reduce sprayer performance.

Grounding of Pails

Solvent pails used when flushing: Follow local code. Use only conductive metal pails, placed on a grounded surface. Do not place the pail on a non-conductive surface, such as paper or cardboard, which interrupts grounding continuity.



Always ground a metal pail: connect a ground wire to the pail. Clamp one end to the pail and the other end to a true earth ground such as a water pipe.

To maintain ground continuity when sprayer is flushed or pressure is relieved: hold metal part of spray gun firmly to the side of a grounded metal pail then trigger the gun.

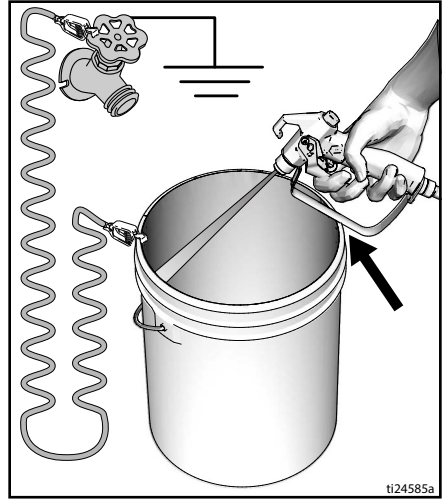

Circuit Protection

Connect sprayers only to circuits which have the properly sized circuit breaker and/or fuses (for unit power requirements see **Technical Data**, pages 60-63).

Setup

Setup

Change Engine or Motor

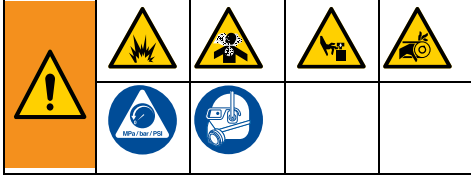

- 1 Turn motor OFF and unplug or turn engine to the OFF/STOP position. Loosen belt guard knob and motor clamp. Perform **Pressure Relief Procedure**, page 15.

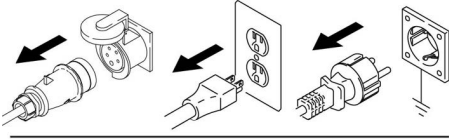

ti41769a

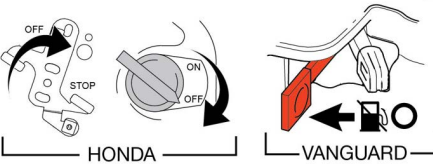

- 2 Lift belt guard. Remove belt. Tilt engine/motor and remove engine/motor.

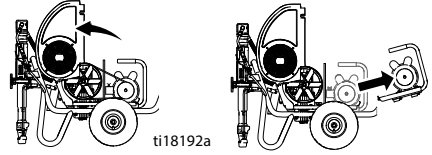

- 3 Tilt engine/motor. Install engine/motor. Install belt. Lower belt guard.

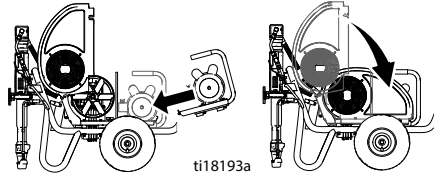

- 4 Swivel motor clamp. Tighten motor clamp and belt guard knob.

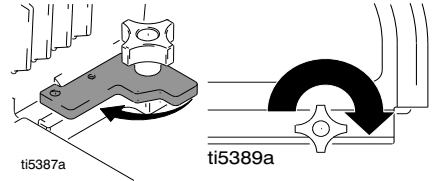

Complete Setup

1. **All sprayers except ProContractor:**
Connect appropriate Graco high-pressure hose to sprayer.

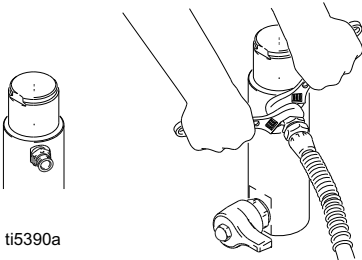

2. Install hose to spray gun and tighten securely.

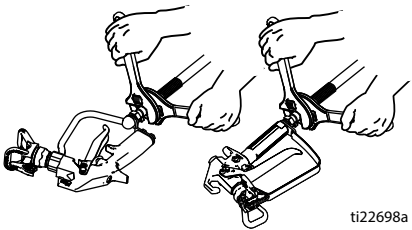

3. Engage gun trigger lock.

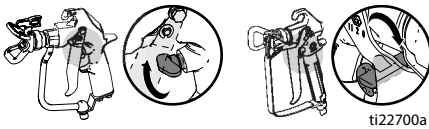

4. Remove Tip Guard.
5. **Standard Series:** Screw inlet strainer to bottom of suction hose and hand tighten securely.

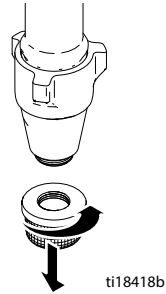

6. When spraying texture, remove inlet strainer and filter bowl screen.

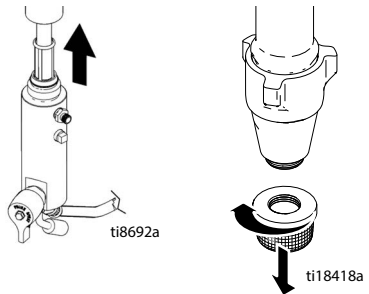

7. Fill throat packing nut with TSL to prevent premature packing wear. Do this each time you spray.

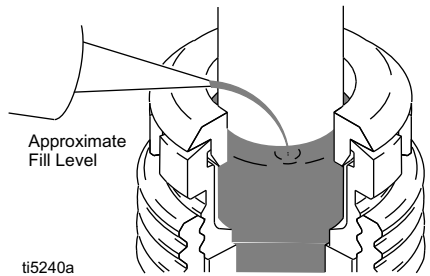

8. Check engine oil level.
GASOLINE ENGINE

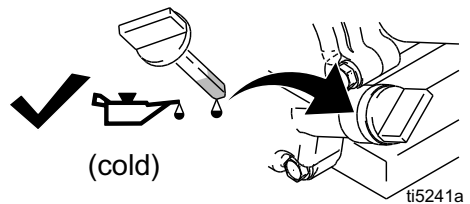

Setup

DIESEL ENGINE

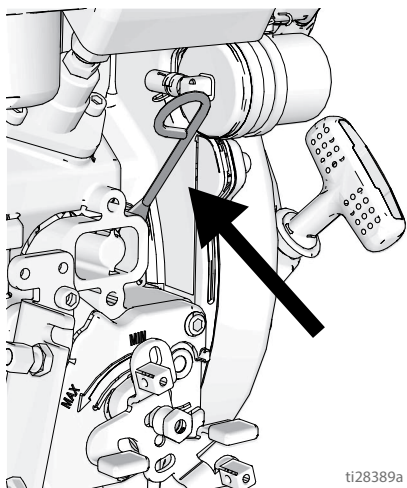

10. Check hydraulic oil level. See page 29 for hydraulic oil specifications. Add hydraulic oil as needed until the level is between the MIN and MAX (Safe Range when cold). Hydraulic tank capacity is five quarts (4.75 liters).



9. Fill fuel tank.

GASOLINE ENGINE

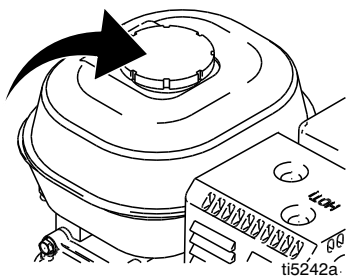

11. Attach sprayer grounding clamp to earth ground.

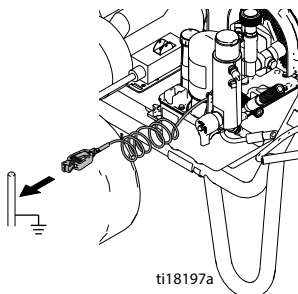

DIESEL ENGINE

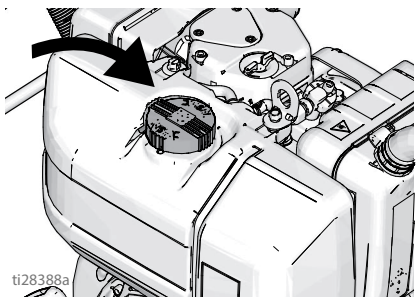

Pressure Relief Procedure



Follow the **Pressure Relief Procedure** whenever you see this symbol.

This equipment stays pressurized until pressure is manually relieved. To help prevent serious injury from pressurized fluid, such as skin injection, splashing fluid and moving parts, follow the **Pressure Relief Procedure** when you stop spraying and before cleaning, checking, or servicing the equipment.

- Engage trigger lock.
- Turn sprayer OFF:
 - Turn gas engine or electric motor ON/OFF switch to OFF. For Vanguard models turn fuel level to OFF position.

OR

 - Move Diesel throttle lever to STOP.

OR

 - Unplug power cord to electric motor.

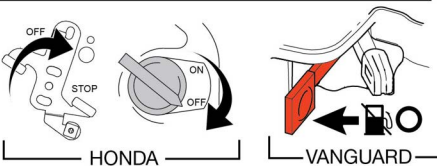
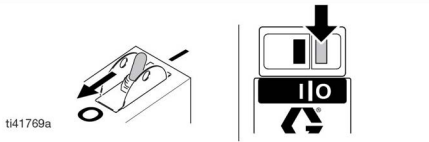
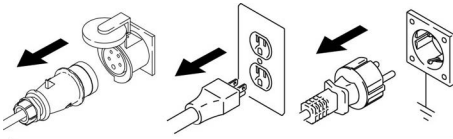

- Move pump valve to OFF and turn pressure control knob fully counter-clockwise to lowest setting.
- Disengage trigger lock. Hold metal part of gun firmly to side of grounded metal pail, and trigger gun to relieve pressure.
- Engage gun trigger lock.
- Turn prime valve down to DRAIN position. Leave prime valve down until ready to spray again.
- If you suspect the spray tip or hose is clogged or that pressure has not been fully relieved:
 - VERY SLOWLY loosen tip guard retaining nut or hose end coupling to relieve pressure gradually.
 - Loosen nut or coupling completely.
 - Clear hose or tip obstruction.

Startup (Internal Combustion Models)

Startup (Internal Combustion Models)



1. Place displacement pump in grounded metal pail partially filled with flushing fluid. Attach ground wire to pail and to earth ground.

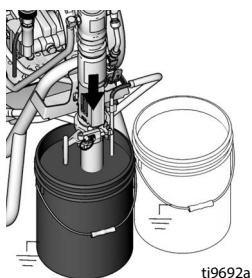

2. Turn prime valve down to DRAIN position. Turn pressure control counterclockwise to lowest pressure.

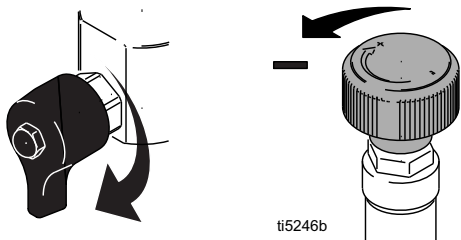

3. Set hydraulic pump valve OFF.

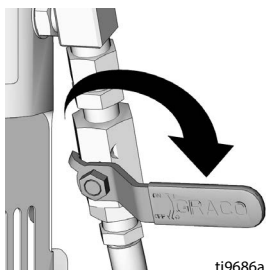

4. Start a gasoline engine, see step 5. Start a Diesel engine, see step 6.

5. Start gasoline engine:
 - a. Move fuel valve to open.

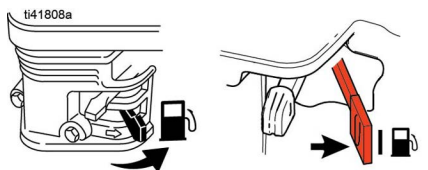

- b. Move choke to closed.

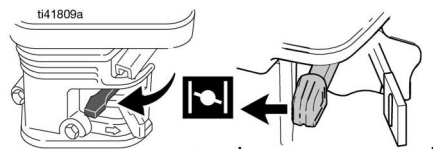

- c. Set throttle to fast.

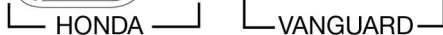
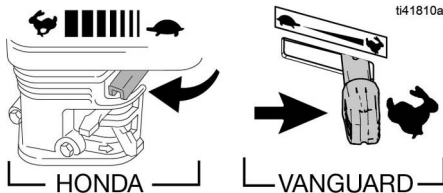

- d. Set engine switch to ON.

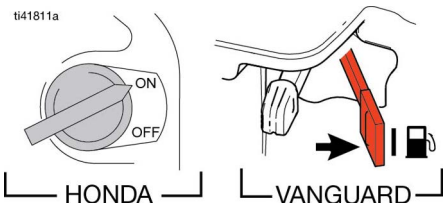

Startup (Internal Combustion Models)

- e. Pull starter rope.

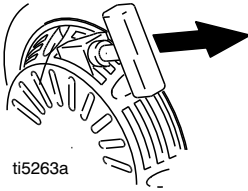

- f. After engine starts, move choke to open.

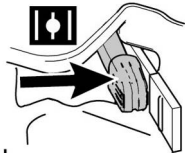
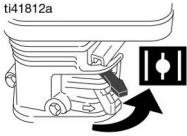

HONDA

VANGUARD

- g. Set throttle to desired setting.

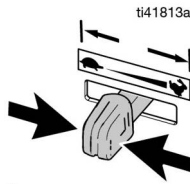
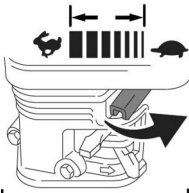

HONDA

VANGUARD

6. Start Diesel engine:

- a. Move throttle lever to MIN position.

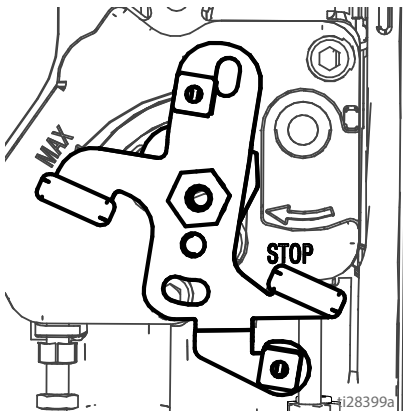

- b. Grip the starter rope handle. Gently pull the rope until it is extended to the full length revealing the RED indicator mark on the rope.

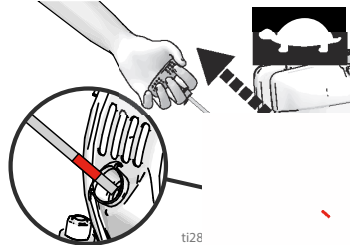

- c. Without releasing the starter rope handle allow the rope to rewind completely.

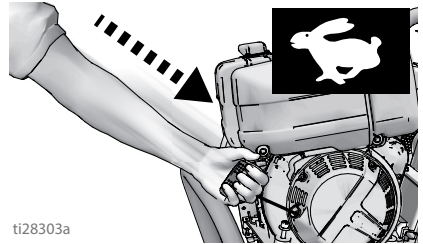

- d. Start the engine by pulling the rope using a firm steady pull.

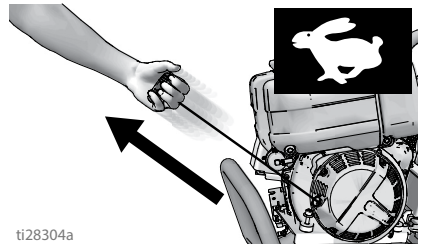

- e. After engine starts move throttle lever to MAX (full throttle) position.

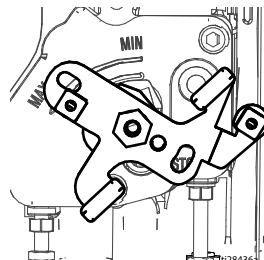

Startup (Internal Combustion Models)

7. Set hydraulic pump valve ON (hydraulic motor is now active).

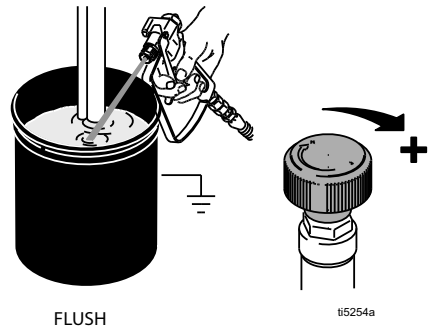
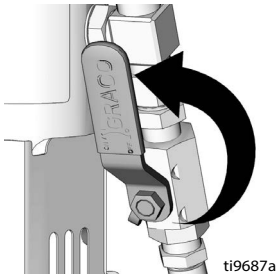

8. Increase pressure enough to start hydraulic motor stroking and allow fluid to circulate for 15 seconds; turn pressure down, turn prime valve horizontal.

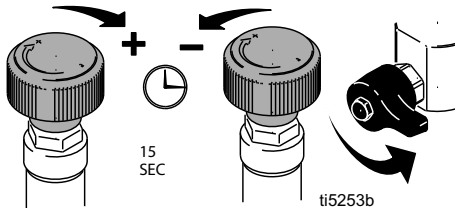

11. Inspect for leaks. If leaks occur, turn sprayer OFF immediately. Perform **Pressure Relief Procedure**, page 15. Tighten leaky fittings. Repeat **Startup** procedure steps 2-8. If no leaks, continue to trigger gun until system is thoroughly flushed.

12. Place siphon tube in paint pail.

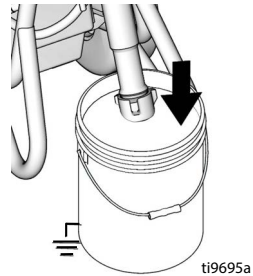

9. Disengage spray gun trigger lock.

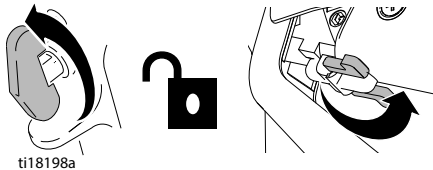

13. Trigger gun again into flushing fluid pail until paint appears.

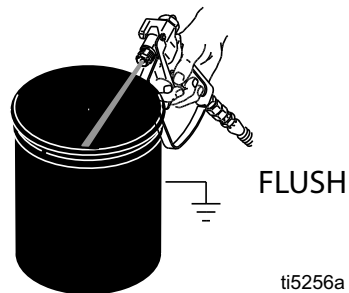

10. Hold gun against grounded metal flushing pail. Trigger gun and increase fluid pressure slowly until pump runs smoothly. Release trigger and allow sprayer to build pressure. Engage trigger lock.

14. Assemble Tip and Guard, page 24.

<p>High-pressure spray is able to inject toxins into the body and cause serious bodily injury. Do not stop leaks with hand or rag.</p>				

Startup (Electric Models)

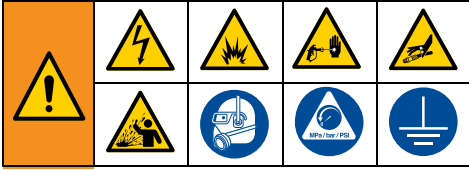

1. Place displacement pump in grounded metal pail partially filled with flushing fluid. Attach ground wire to pail and to earth ground.

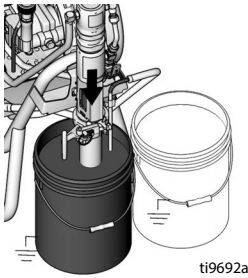

2. Turn prime valve down. Turn pressure control counterclockwise to lowest pressure.

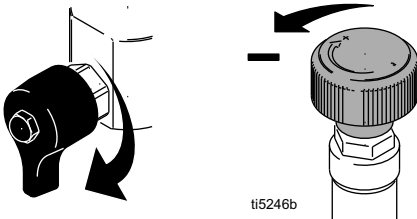

3. Set hydraulic pump valve OFF.

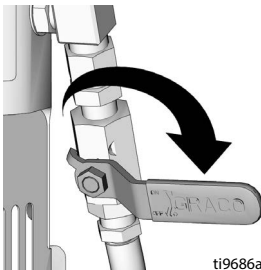

4. Plug cord into outlet.

For three phase electric motors: If red phase sequence light is on or blinking, remove plug from outlet and turn phase sequence screw 180°.

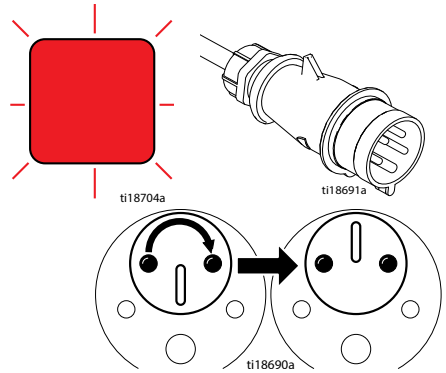

5. Turn motor ON.

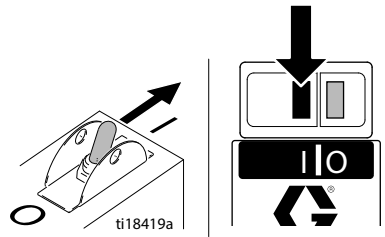

6. Set hydraulic pump valve ON (hydraulic motor is now active).

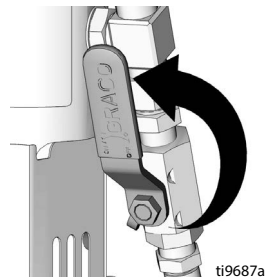

Startup (Electric Models)

- Increase pressure enough to start hydraulic motor stroking and allow fluid to circulate for 15 seconds; turn pressure down, turn prime valve horizontal.

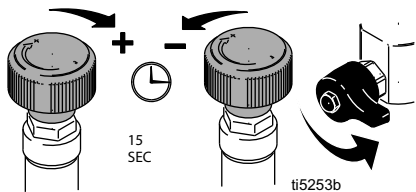

- Take spray gun trigger safety OFF.

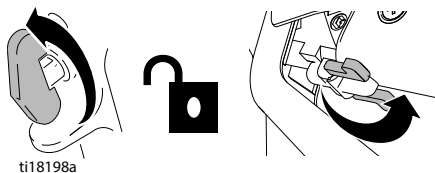

- Hold gun against grounded metal flushing pail. Trigger gun and increase fluid pressure slowly until pump runs smoothly.

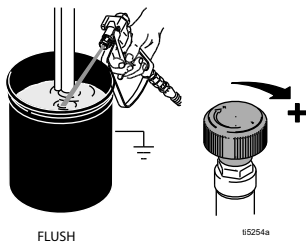

<p>High-pressure spray is able to inject toxins into the body and cause serious bodily injury. Do not stop leaks with hand or rag.</p>				

- Inspect fittings for leaks. If leaks occur, turn sprayer OFF immediately. Perform **Pressure Relief Procedure**, page 15. Tighten leaky fittings. Repeat **Startup** procedure steps 2-8. If no leaks, continue to trigger gun until system is thoroughly flushed.

- Place displacement pump in paint pail.

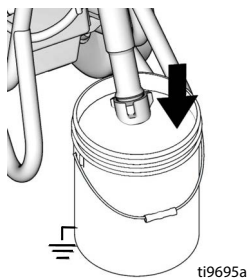

- Trigger gun again into flushing fluid pail until paint appears.

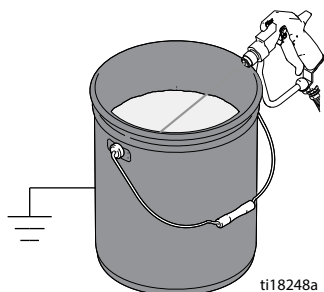

- Assemble Tip and Guard, page 24.

How to Spray

Switch Tip™ and Guard Assembly



1. Perform **Pressure Relief Procedure**, page 15.
2. Engage gun trigger lock. Insert Switch Tip. Insert seat and OneSeal™.

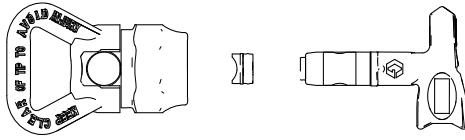

ti13023a

3. Insert Switch Tip and face forward.

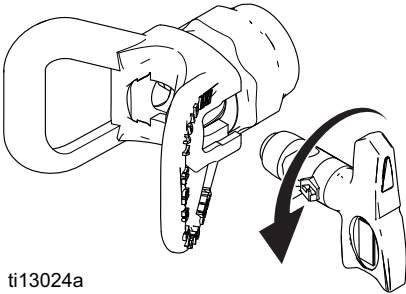

ti13024a

4. Screw assembly onto gun. Tighten.

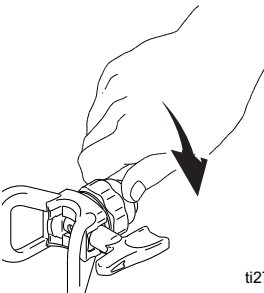

ti2710a

Spray

1. Spray test pattern. Increase pressure to eliminate heavy edges. Use smaller tip size if pressure adjustment can not eliminate heavy edges.

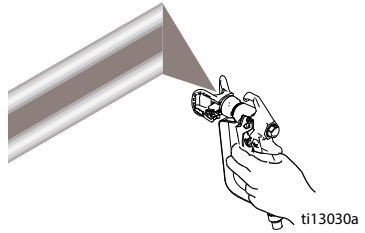

ti13030a

2. Hold gun perpendicular, 10-12 in. (25-30 cm) from surface. Spray back and forth. Overlap by 50%. Trigger gun after moving and release before stopping.

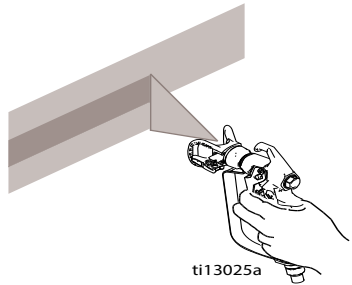

ti13025a

How to Spray

Clear Tip Clogs



1. Release trigger, engage trigger lock. Rotate Switch Tip. Disengage trigger lock. Trigger gun to clear clog.

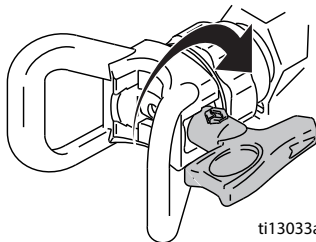

2. Engage trigger lock. Return Switch Tip to original position. Disengage trigger lock and continue spraying.

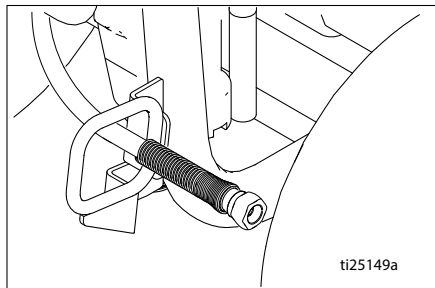
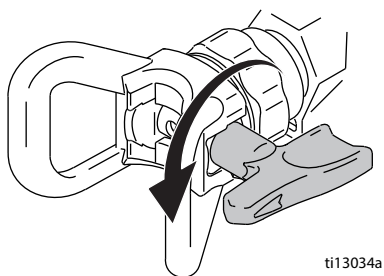

2. Lift and turn pivot lock 90° to unlock hose reel. Pull on hose to remove it from hose reel.

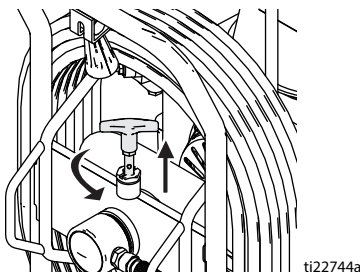

3. Pull reel handle down and turn clockwise to reel in hose.

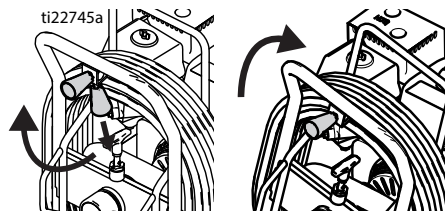

4. **NOTE:** The hose reel can be locked into two positions: Usage and Storage.

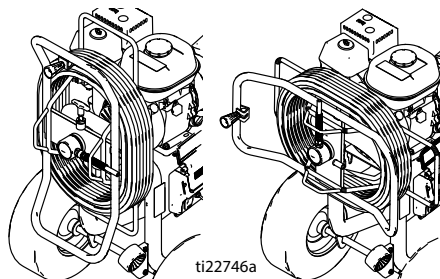

Hose Reel

(ProContractor Series only)



To avoid injury, keep your head clear of hose reel while winding up hose.

1. Make sure hose is routed through hose guide.

Clean Up



1. Perform **Pressure Relief Procedure**, page 15.
2. Remove Guard and SwitchTip.

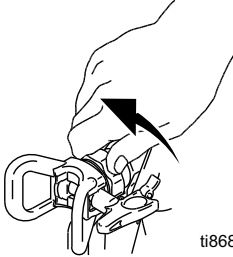

ti8687a

3. Remove displacement pump from paint and place in flushing fluid. Use water for water-based paint and mineral spirits for oil based paint.

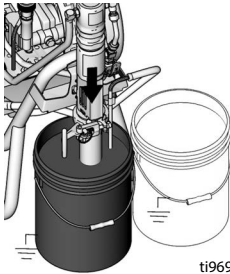

ti9692a

4. Turn motor switch ON or turn engine ON and start engine. Turn hydraulic pump valve ON. Turn prime valve forward to SPRAY position.

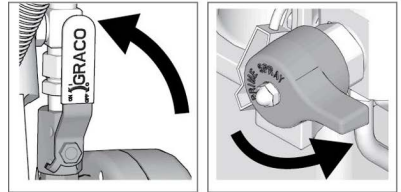
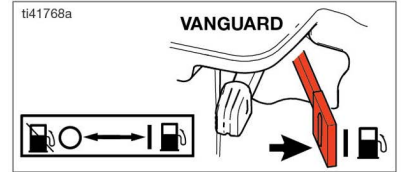
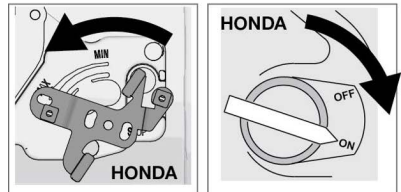
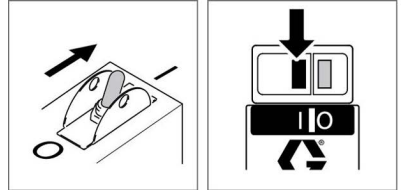

5. Hold gun against pail. Disengage trigger lock. Turn pressure control up until motor begins to drive pump. Trigger gun until flushing fluid appears.

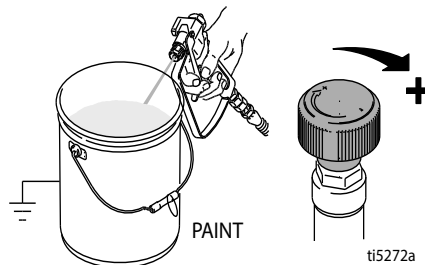

ti5272a

Clean Up

6. Move gun to waste pail, hold gun against pail, trigger gun to thoroughly flush system. Release trigger and engage trigger lock.

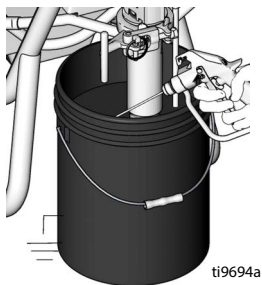

7. While continuing to trigger gun, turn prime valve down. Then release gun trigger. Allow flushing fluid to circulate until fluid comes out of drain tube clear.

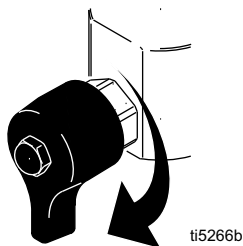

8. Raise displacement pump above flushing fluid and run sprayer for 15 to 30 seconds to drain fluid. Turn hydraulic valve OFF. Turn engine OFF or turn electric motor OFF and unplug.

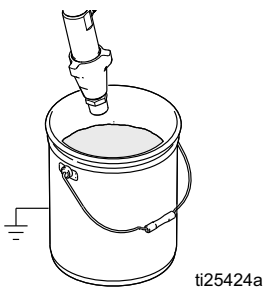

9. Engage trigger lock. Remove filters from gun and sprayer, if installed. Clean and inspect. Reinstall filters.

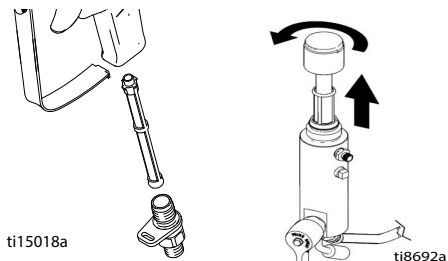

10. Unscrew and remove inlet strainer. Clean and replace strainer if necessary.

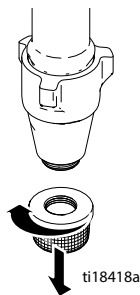

11. If flushing with water, flush again with mineral spirits, or Pump Armor, to leave a protective coating to prevent freezing or corrosion.
12. Wipe sprayer, hose and gun with a rag soaked in water or mineral spirits.

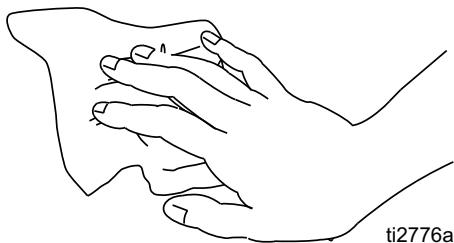

Maintenance

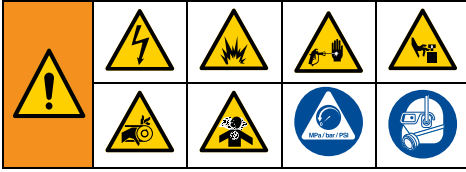

NOTE: For detailed engine maintenance and specifications, refer to separate Honda or Kohler Engine Owner's Manual, supplied.

DAILY: Check engine oil level and fill as necessary.

DAILY: Check hydraulic oil level and fill as necessary.

DAILY: Check hose for wear and damage.

DAILY: Check gun trigger lock for proper operation.

DAILY: Check prime/drain valve for proper operation.

DAILY: Check and fill the fuel tank.

DAILY: Check that displacement pump is tight.

DAILY: Check level of Throat Seal Liquid (TSL) in displacement pump packing nut. Fill nut, if necessary. Keep TSL in nut to help prevent fluid buildup on piston rod and premature wear of packings and pump corrosion.

GASOLINE ENGINE, AFTER THE FIRST 20 HOURS OF OPERATION: Drain engine oil and refill with clean oil. Reference Honda or Vanguard Engine Owner's Manual for correct oil grade.

DIESEL ENGINE, AFTER THE FIRST 50 HOURS OF OPERATION: Drain engine oil and refill with clean oil. Replace oil filter. Reference Kohler Engine Owner's Manual for correct oil grade.

WEEKLY: Remove engine air filter cover and clean element. Replace element, if necessary. If operating in an unusually dusty environment: check filter daily and replace, if necessary.

Replacement elements can be purchased from your local HONDA/Kohler/Vanguard dealer.

WEEKLY/DAILY: Remove any debris or media from hydraulic rod.

AFTER EACH 100 HOURS OF OPERATION: Change engine oil. Reference Honda or Vanguard Engine Owner's Manual for correct oil viscosity.

DIESEL ENGINE, AFTER EACH 250 HOURS OF OPERATION: Drain engine oil and refill with clean oil. Replace oil filter. Reference Kohler Engine Owner's Manual for correct oil grade.

SEMI-ANNUALLY: Check belt wear. Replace if necessary.

YEARLY OR 2000 HOURS: Replace belt. Replace hydraulic oil with Mobil SHC 526 or other high quality ISO viscosity grade 68 hydraulic oil. Replace hydraulic oil filter 246173.

SPARK PLUG: Use only BPR6ES (NGK) or W20EPR-U (NIPPONDENSO) plug. Gap plug to 0.028 to 0.031 in. (0.7 to 0.8 mm). use spark plug wrench when installing and removing plug.

Maintenance

Hydraulic Oil/Filter Change

1. Place drip pan or rags under sprayer to catch hydraulic oil that drains out.
2. Remove drain plug (2). Allow hydraulic oil to drain.
3. Unscrew filter (227) slowly - oil runs into groove and drains out rear.
4. Remove and replace ball (216), spring (217), and retainer (215).
5. Install drain plug (2) and oil filter (227). tighten oil filter additional 3/4 turn after gasket contacts the base.
6. Fill with oil tank with five quarts (4.75 liters) of hydraulic oil. See page 26 for hydraulic oil specifications.
7. Check oil level.

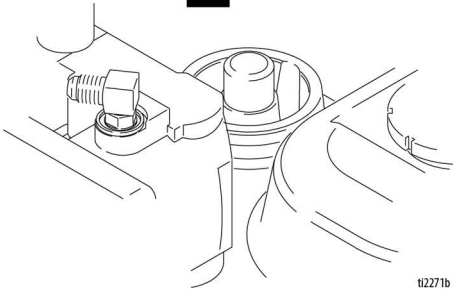
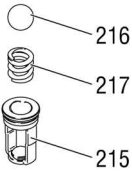
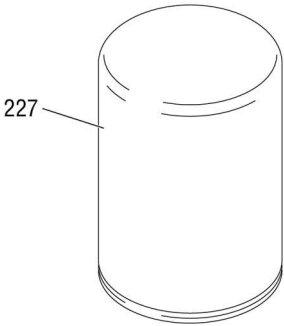

t12271b

Troubleshooting



Problem	Cause	Solution
Internal combustion engine pulls hard (won't start)	Hydraulic pressure is too high	Turn hydraulic pressure knob counterclockwise to lowest setting
Gasoline engine does not start	Switch OFF, low oil, no gasoline	Consult engine manual
	Fuel shut off valve closed	Open fuel shut off valve
Gasoline engine does not work properly	Faulty engine	Consult engine manual
	Elevation	Refer to Engine Repair Kit, 4.0 hp - 288678 / 5.5 hp - 248943 / 6/5 hp - 248944 / 9.0 hp - 248945
Diesel engine does not start	No fuel Incorrect injection timing, rings worn or sticking.	Consult engine manuals
Diesel engine does not work properly	Faulty engine	Consult engine manuals
	Poor fuel quality	Drain fuel tank and replace fuel with good clean fuel
Internal combustion engine operates, but displacement pump does not operate	Hydraulic pump valve is OFF	Set hydraulic pump valve ON
	Pressure setting too low	Increase pressure, page 18
	Displacement pump outlet filter (if used) is dirty or clogged	Clean the filter
	Tip or tip filter (if used) is clogged	Remove tip and/or filter and clean
	Hydraulic fluid too low	Shut off sprayer. Add fluid*. See page 16
	Belt worn or broken or off	Replace.
	Hydraulic pump worn or damaged	Bring sprayer to Graco distributor for repair
	Dried paint seized paint pump rod	Service pump. See manual 334654
Displacement pump operates, but output is low on upstroke	Hydraulic motor not shifting	Set pump valve OFF. Turn pressure down. Turn engine OFF. Pry rod up or down until hydraulic motor shifts.
	Piston ball check not seating properly	Service piston ball check. See manual 334654
	Piston packings worn or damaged	Replace packings. See manual 334654

Troubleshooting

Problem	Cause	Solution
Displacement pump operates, but output is low on down stroke and/or on both strokes	Piston packings worn or damaged	Tighten packing nut or replace packings. See manual 334654
	Intake valve ball check not seating properly	Service intake valve ball check. See manual 334654
	Suction tube air leak	
	Hydraulic oil filter is dirty	Replace filter.
Paint leaks and runs over side of wet cup	Loose wet cup	Tighten wet cup enough to stop leakage
	Throat packings worn or damaged	Replace packings. See manual 334654
Excessive leakage around hydraulic motor piston rod wiper	Piston rod seal worn or damaged	Replace these parts. See manual 334654
Fluid delivery is low	Pressure setting too low	Increase pressure, page 18
	Displacement pump outlet filter (if used) is dirty or clogged	Clean or replace.
	Contractor gun filter (if used) is dirty or clogged	Clean or replace.
	Intake line to pump inlet is not tight	Tighten.
	Hydraulic motor is worn or damaged	Bring sprayer to Graco distributor for repair.
	Large pressure drop in fluid hose	Reduce length or increase diameter.
The sprayer overheats	Paint buildup on hydraulic components	Clean
	Oil level is low	Fill with oil. See page 16
Spitting from gun	Air in fluid pump or hose	Check for loose connections on siphon assembly, tighten, then reprime pump
	Loose intake suction	Tighten
	Fluid supply is low or empty	Refill supply container
Pump noise	Low hydraulic fluid level	Turn sprayer OFF. Add fluid*. See page 16
Electric motor does not operate	Power switch is not ON	Turn power switch ON
	Tripped circuit breaker	Check circuit breaker at power source. Reset motor switch
*Check hydraulic fluid level often. Do not allow it to become too low. Use only Graco hydraulic fluid, page 16.		

Standard Series Pump

Removal



See pump manual 334654 for pump repair.

1. Flush pump.
2. Perform **Pressure Relief Procedure**, page 15.
3. Remove strainer and paint hose.

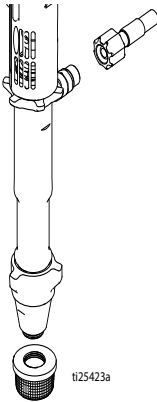

4. Push retaining ring up; push out pin.

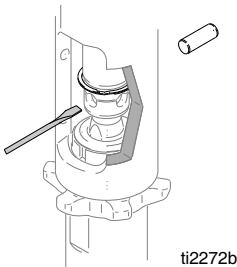

5. Loosen jam nut. Unscrew pump.

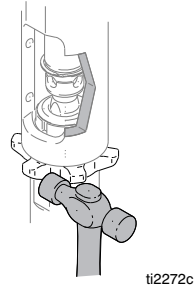

Installation

NOTICE

If pump jam nut loosens during operation, the threads of the bearing housing and drive train will be damaged. Tighten jam nut as specified.

1. Screw jam nut to bottom of pump threads. Screw pump completely into manifold. Unscrew pump from manifold until pump outlet aligns with hose. Hand tighten jam nut, then tap 1/8 to 1/4 turn with hammer.

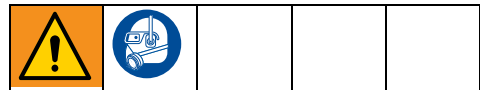
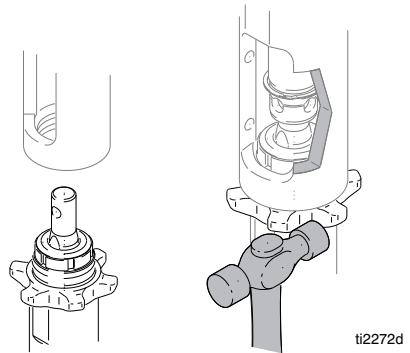

If pin is loose, parts could break off and project through the air, resulting in serious injury or property damage. Make sure pin is properly installed.

ProContractor Series Pump

2. Slowly pull engine starter rope until pump rod pin hole is aligned with hydraulic rod hole. Push pin into hole. Push retaining ring into groove.

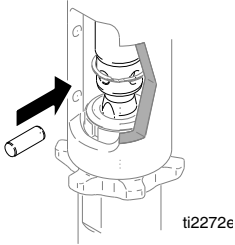

3. Fill packing nut with Graco TSL.

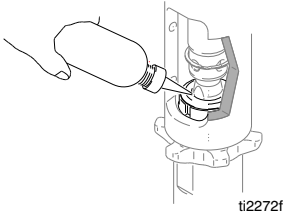

ProContractor Series Pump

Removal



See pump manual 334654 for pump repair.

1. Flush pump.
2. Perform **Pressure Relief Procedure**, page 15.

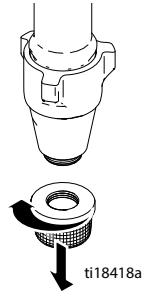

3. Remove paint hose fitting and paint hose from pump fitting.

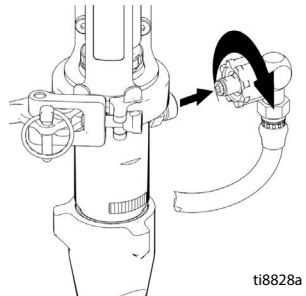

ProContractor Series Pump

- Slide coupler cover up to fully expose rod couplers.

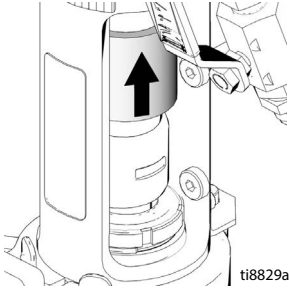

- Remove rod couplers.

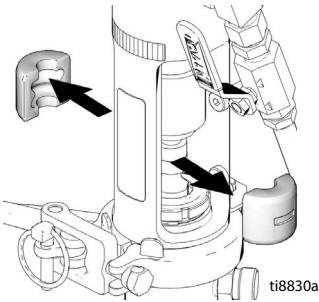

- Remove pin.

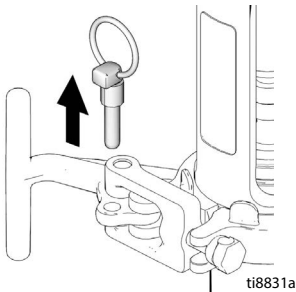

NOTE: Support pump with your hand before opening t-handle.

- Open clamp.

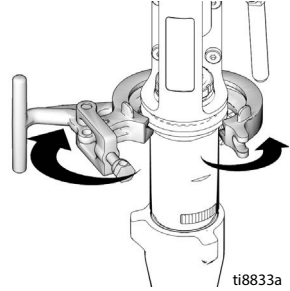

- Remove pump from unit.

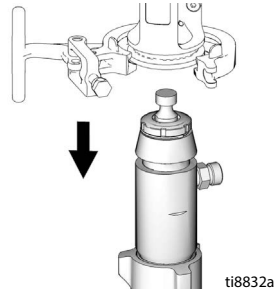

Installation

- If needed, place pump rod in adjustment casting and pull pump to extend rod.

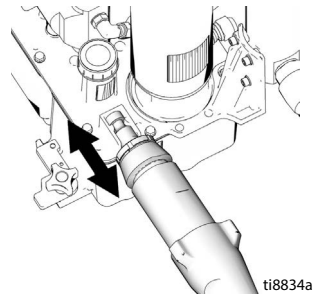

- Reverse removal steps to reassemble pump.

Notes

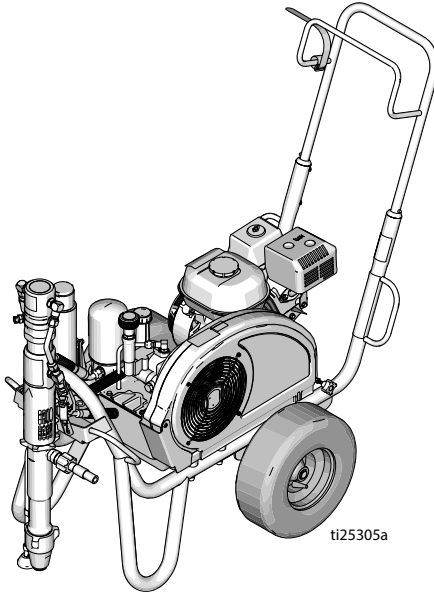

DutyMax EH/GH230/300 HD Standard Series

DutyMax EH/GH230/300 HD Standard Series Parts



DutyMax EH/GH230/300 HD Standard Series

GH230/300 Standard Series Frame and Belt Guard Parts

Ref.	Torque	Ref.	Torque
	120-130 in-lb (13.6 - 14.7 N•m)		Inflate tires to 25-35 psi (1.7-2.4 bar)

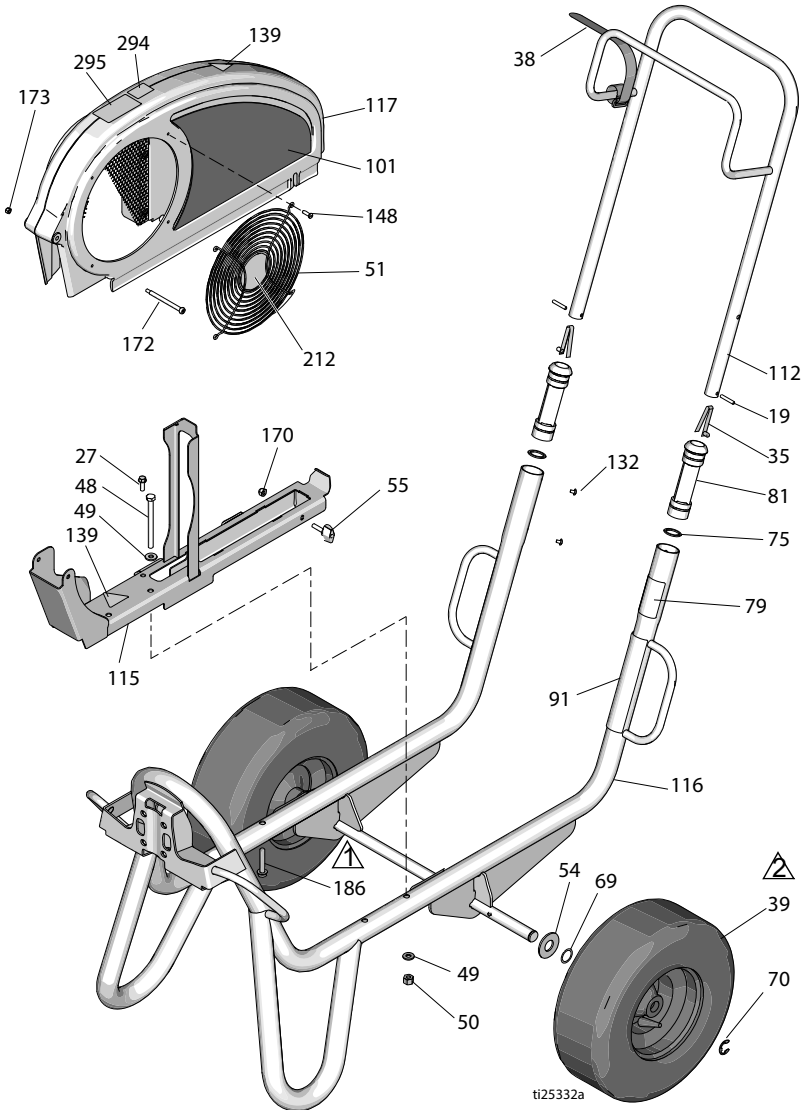

DutyMax EH/GH230/300 HD Standard Series

Parts List

Ref.	Part	Description	Qty.	Ref.	Part	Description	Qty.
19	101354	PIN, spring, straight	2		17D046	LABEL, brand, side (EH300DI)	1
27	260212	SCREW, hex washer hd, thd form	1		17D048	LABEL, brand, side (GH300DI)	1
35	112827	BUTTON, snap	2				
38	114271	STRAP, retaining	1	112	24M397	HANDLE, cart	1
39	119509	WHEEL, pneumatic	2	115	24M086	RAIL, belt guard, assy	1
48	867539	SCREW, cap, hex hd	2	116	24M085	FRAME, cart, weldment	1
49	100527	WASHER, plain	4	117	248973	GUARD, belt assembly, painted (includes 51, 148, 172, 173)	1
50	110838	NUT, lock	2				
51	117284	GRILL, fan guard	1				
54	156306	WASHER, flat	2	132	109032	SCREW, mach, pnh	4
55	17D813	NUT, hand	2	139▲	16M768	LABEL, warning	2
69	116038	WASHER, wave spring	2	141▲	15Y963	LABEL, read instructions	1
70	120211	RING, retaining, e-ring	2	148	115477	SCREW, mach, torx pan hd	4
75	15J645	WASHER	2				
79▲	189246	LABEL, warning	1	170	102040	NUT, lock, hex	1
	17D947	LABEL, warning, multi-languages	1	172	119434	SCRWE, shoulder, skt hd	1
				173	116969	NUT, lock	1
81	192027	SLEEVE, cart	2	212	16N398	LABEL, direction (EH/GH300DI)	1
91▲	194317	LABEL, warning	1				
	16N948	LABEL, warning, ISO	1	294	16D576	LABEL, made in USA	1
	17D947	LABEL, warning, multi-languages	1	295	16X983	LABEL, standard series	1
101	17D042	LABEL, brand, side (EH230DI)	1	▲Danger and Warning labels are available at no cost.			
	17D044	LABEL, brand, side (GH230DI)	1				

DutyMax EH/GH230/300 HD Standard Series

DutyMax EH230 HD Electric Motor Parts

Ref.	Torque	Ref.	Torque
▲1	25-30 in-lb (2.9 - 3.4 N•m)	▲3	Apply Loctite 242
▲2	215-235 in-lb (24.3 - 26.6 N•m)	▲4	58-62 in-lb (6.6 - 7.0 N•m)

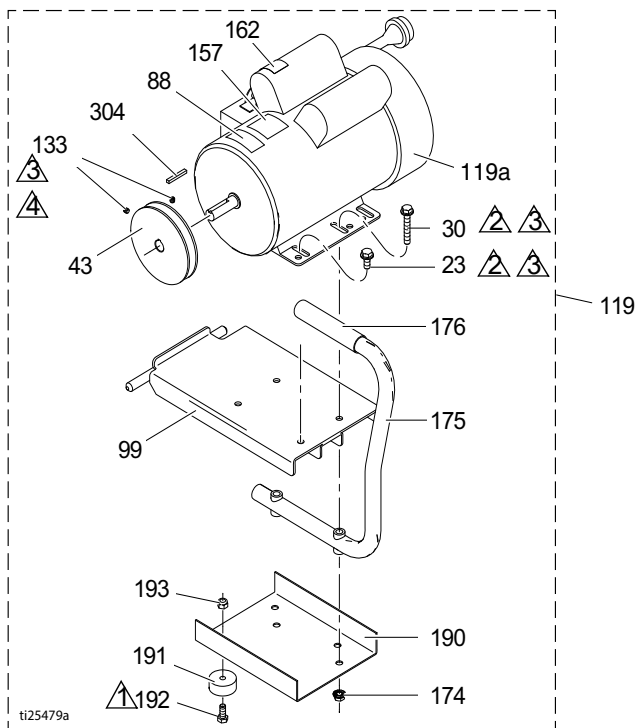

Ref.	Part	Description	Qty.	Ref.	Part	Description	Qty.
23	110963	SCREW, cap, flange head	2	174	110996	NUT, hex, flange head	4
30	114653	SCREW, cap, flange head	2	175	246214	HANDLE, conversion	1
43	16N612	PULLEY	1	176	111700	GRIP, handle	1
44	116914	BELT, V-Grip-notch (not shown)	1	190	15F217	PLATE, isolator, bottom	1
88▲	15K616	LABEL, caution	1	191	113817	BUMPER	4
99	15E585	BRACKET, mounting, elec. motor	1	192	100057	SCREW, cap, hex hd	4
119	24M668	KIT, 3.0 hp (includes all parts listed on this page)	1	193	111040	NUT, lock, insert, nylock, 5/16	4
119a	15E669	MOTOR, electric 3 HP, 230V AC	1	304	117632	KEY, square 3/16 x 1.25	1
133	100002	SCREW, set	2	▲Danger and Warning labels are available at no cost			
157	15B804	LABEL, Graco	2				
162▲	189930	LABEL, warning	1				

DutyMax EH/GH230/300 HD Standard Series

DutyMax GH230 HD Gasoline Engine Parts

Ref.	Torque	Ref.	Torque
▲1	120-130 in-lb (13.6 - 14.7 N•m)	▲3	Apply Loctite 242
▲2	58-62 in-lb (6.6 - 7.0 N•m)		

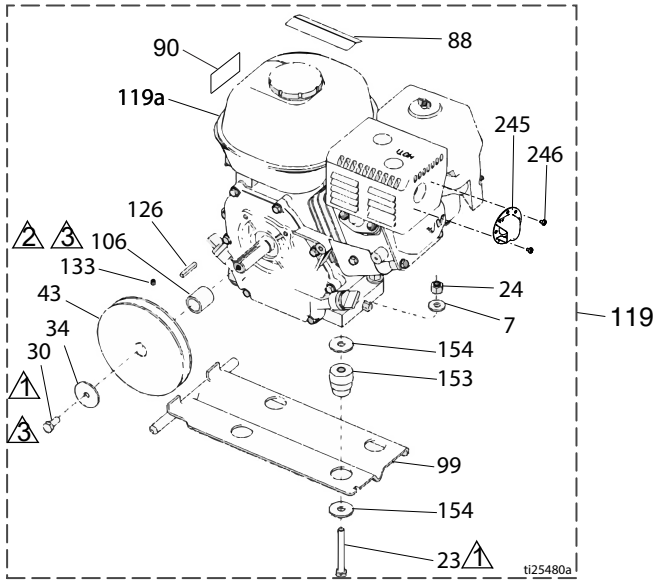

Ref.	Part	Description	Qty.	Ref.	Part	Description	Qty.
7	100023	WASHER, flat	4	119	248944	KIT, gas engine 6.5 hp (includes all parts listed on this page)	2
23	113664	SCREW, cap, hex hd	4	119a	116298	ENGINE, 6.5 gas	1
24	110838	NUT, lock	4	126	117632	KEY, square, 3/16 x 1.25	1
30	108842	SCREW, cap, hex hd	2	133	100002	SCREW, set	1
34	112717	WASHER	1	153	15E888	DAMPENER, motor mount	4
43	116908	PULLEY, 5.50 in.	1	154	108851	WASHER, plain	8
44	119433	BELT, V-Grip-notch (not shown)	1	245	128099	DEFLECTOR, exhaust	1
50	110838	NUT, lock	4	246	128101	SCREW, tapping	2
88▲	194126	LABEL, warning	1	▲Danger and Warning labels are available at no cost			
90▲	16Y720	LABEL, warning, ISO engine	1				
99	15F157	BRACKET, mounting, engine	1				
106	15B314	SLEEVE, motor shaft	1				

DutyMax EH/GH230/300 HD Standard Series

DutyMax EH300 HD Electric Motor Parts

Ref.	Torque	Ref.	Torque
▲ 1	25-30 in-lb (2.9 - 3.4 N·m)	▲ 3	Apply Loctite 242
▲ 2	215-235 in-lb (24.3 - 26.6 N·m)	▲ 4	58-62 in-lb (6.6 - 7.0 N·m)

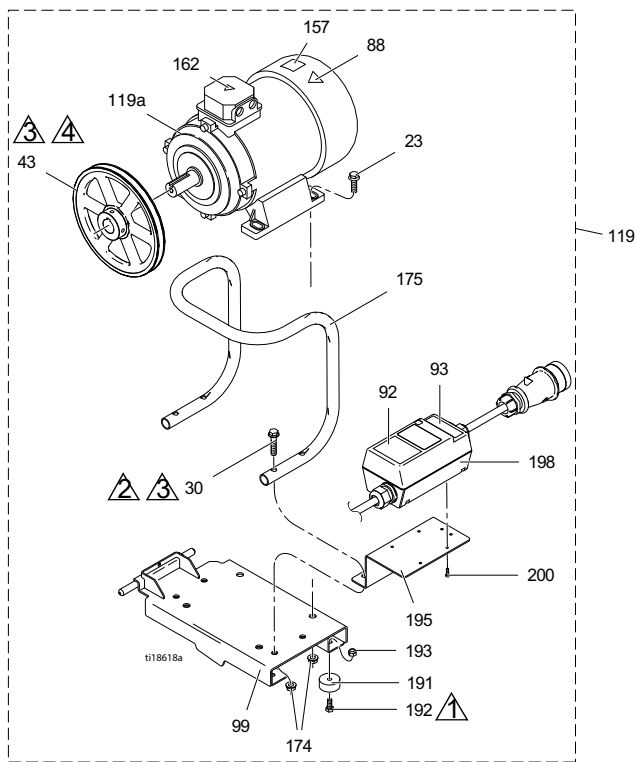

Ref.	Part	Description	Qty.	Ref.	Part	Description	Qty.
23	111193	SCREW, cap, flange head	4	174	112958	NUT, hex, flanged	8
30	116780	SCREW, hex, hd, flanged	4	175	16M473	TUBE, handle, conversion	1
43	125811	PULLEY, cast iron, 8.75 in	1	191	113817	BUMPER	4
88▲	15K616	LABEL, caution	1	192	100057	SCREW, cap, hex hd	4
92	16N399	LABEL, motor switch box on-off	1	193	111040	NUT, lock, insert, nylock, 5/16	4
93	16N400	LABEL, red light indicator	1	195	16M474	BRACKET, motor starter	1
99	16M467	BRACKET, mounting, motor, EH300	1	198	24N064	STARTER, motor assembly	1
119	24M669	KIT, motor (includes all parts listed on this page)	1	200	119236	SCREW, plastite	4
119a	24N019	MOTOR, elec., 400 VAC, 50 Hz, 7.3 hp	1	▲ Danger and Warning labels are available at no cost			
▲ 162	189930	LABEL, caution	1				

DutyMax EH/GH230/300 HD Standard Series

DutyMax GH300 HD Gasoline Engine Parts



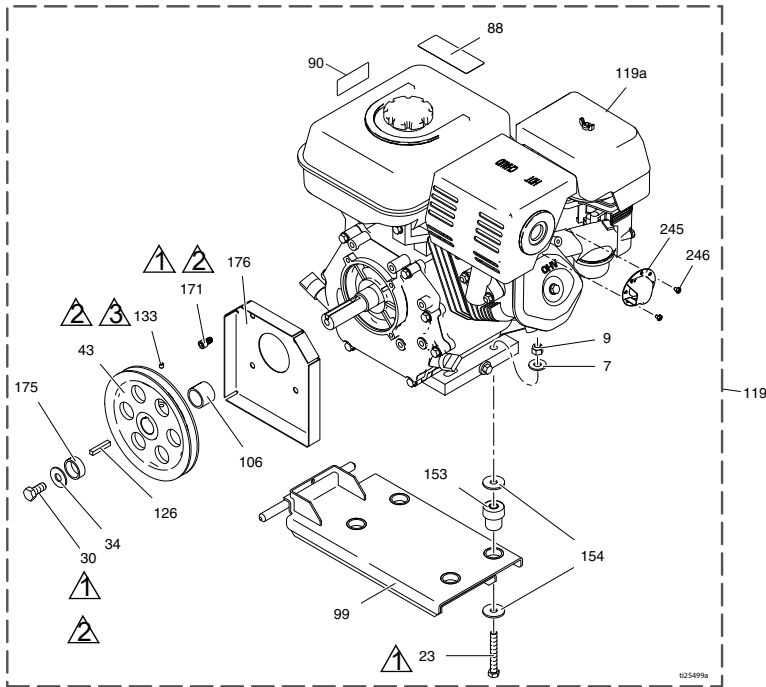



Ref.	Torque	Ref.	Torque
▲1	120-130 in-lb (13.6 - 14.7 N•m)	▲3	58-62 in-lb (6.6 - 7.0 N•m)
▲2	Apply Loctite 242		



Ref.	Part	Description	Qty.	Ref.	Part	Description	Qty.
7	100132	WASHER, flat	4	119a	803900	ENGINE, gasoline, 9.0 hp (Honda)	1
	100023	WASHER, flat (Vanguard)	4	24P301		ENGINE, gasoline, 9.0 hp (China only)	1
9	110838	NUT, lock	4	248945V		ENGINE, gasoline, 10 hp (Vanguard, California compliant)	1
23	106212	SCREW, cap, hex hd	4	126	119484	KEY, parallel, square	1
	113664	SCREW, cap, hex hd (Vanguard)	4	133	100002	SCREW, set	1
30	116645	SCREW, cap, hex head	1	153	195515	DAMPENER, motor mount	4
34	100696	WASHER, wrought	1	15E888		DAMPENER, motor mount (Vanguard)	4
43	119401	PULLEY	1	154	108851	WASHER, plain	8
44	119432	BELT, V-Grip-notch (not shown)	1	171	C20010	SCREW, cap, socket head	4
88▲	194126	LABEL, warning	1	175	15E764	SPACER, shaft, engine	1
90▲	16Y720	LABEL, warning, ISO engine	1	176	15E973	SHIELD, engine shaft	1
99	15E583	BRACKET, mounting, engine	1	245	124145	DEFLECTOR, exhaust	1
106	15E586	SLEEVE, shaft, engine	1	246	128101	SCREW, tapping	3
119	248945	KIT, gas engine 9.0 hp (includes all parts listed on this page)	1	▲Danger and Warning labels are available at no cost			
119	25P354	KIT, gas engine, 9.0 hp (China only)	1				

DutyMax EH/GH230/300 HD Standard Series

Standard Series Reservoir & Filter Parts

Ref.	Torque	Ref.	Torque
 1	58-62 in-lb (6.6 - 7.0 N•m)	 5	15-25 in-lb (1.7 - 2.8 N•m)
 2	Apply Loctite 242	 6	Apply Loctite 277
 3	90-110 in-lb (10.2 - 12.4 N•m)	 7	110-120 in-lb (12.4 - 13.6 N•m)
 4	355-395 in-lb (40.1 - 44.6 N•m)		

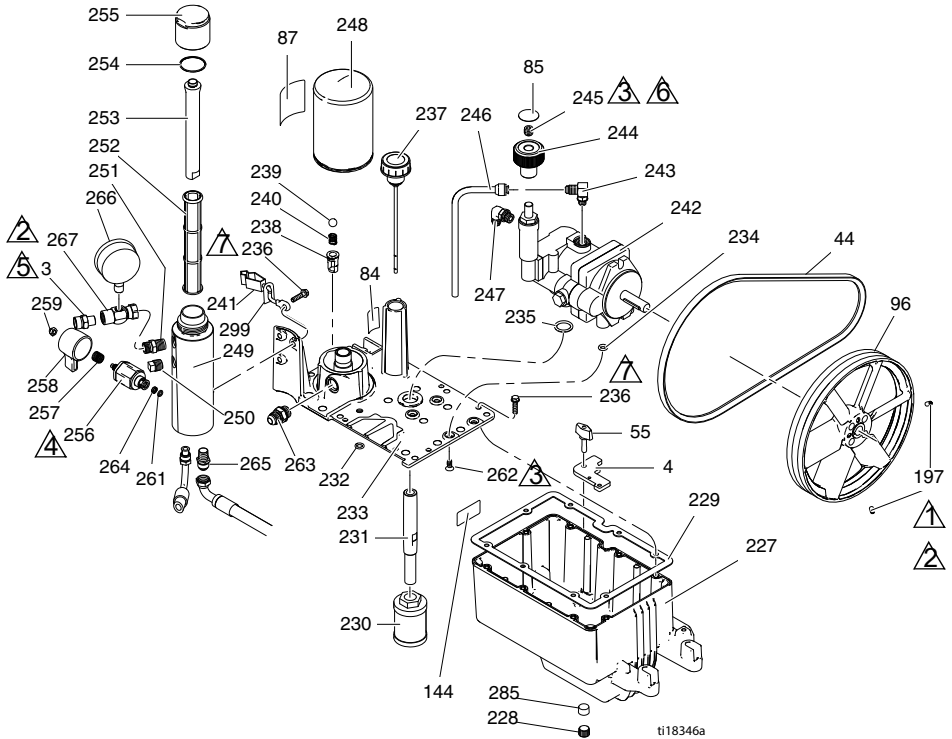

DutyMax EH/GH230/300 HD Standard Series





Standard Series Reservoir and Filter Parts List

Ref.	Part	Description	Qty.	Ref.	Part	Description	Qty.
3	196178	FITTING, outlet (EH/GH230DI)	1	242	249003	PUMP, hydraulic (EH/GH230DI)	1
	183285	FITTING, outlet, (EH/GH300DI)	1	243	110792	FITTING, elbow, male, 90°	1
4	15E476	BRACKET, retainer, motor	1	244	15B438	KNOB, pressure	1
				245	117560	SCREW, set, socket head	1
44	116914	BELT, V, AX42 (EH230DI)	1	246	246167	TUBE, hydraulic, case drain	1
	119433	BELT, V, AX41 (GH230DI)	1				
	125834	BELT, V, AX48 (EH300DI)	1	247	116829	FITTING, elbow, hydraulic w/o rings	1
	119432	BELT, V, AX44 (GH300DI)	1				
55	15D862	NUT, hand	2	248	246173	FILTER, oil, spin on	1
84	198585	LABEL, hydraulic fluid, GH	1	249	15E599	HOUSING, filter	1
				250	15G331	PLUG, pipe	1
85	15A464	LABEL, control	1	251	196178	ADAPTER, nipple	1
87	189892	LABEL, Graco	1	252	244067	FILTER, fluid	1
96	15E410	PULLEY, fan	1	253	15C766	TUBE, diffusion	1
144	15K440	LABEL, brand, GH/EH cooling	1	254	117285	PACKING, o-ring	1
				255	15C765	CAP, filter	1
197	120087	SCREW, set, 1/4 x 1/2	2	256*	287879	VALVE, drain, assy	1
227	15J513	TANK, reservoir, blue	1	257*	114708	SPRING, comp	1
228	101754	PLUG, pipe	1	258*	15G563	HANDLE, valve	1
229	120604	GASKET, reservoir	1	259*	116424	NUT, cap	1
230	116919	FILTER	1	261*	193710	SEAL, seat, valve	1
231	15E587	TUBE, suction	1	262	117471	SCREW, mach, hex flat head	4
232	154594	PACKING, o-ring	1				
233	15M056	COVER, reservoir	1	263	120184	FITTING, hydraulic	1
234	107188	PACKING, o-ring	4	264*	193709	SEAT, valve	1
235	156401	PACKING, o-ring	1	265	121311	FITTING, elbow, 45° street	1
236	119426	SCREW, mach, hex washer hd	11	266	102814	GAUGE	1
				267	243683	UNION, swivel	1
237	120726	CAP, breather, filter	1	285	116618	MAGNET	1
238	198841	RETAINER, ball, pressure bypass	1	299	290079	LABEL, ground warning, English	1
239	100084	BALL, metallic	1				
240	116967	SPRING, compression	1		16Y633	LABEL, ground warning, Chinese	1
241	237686	WIRE, ground assembly w clamp	1				

* Included in Drain Valve Kit 245103

DutyMax EH/GH230/300 HD Standard Series

Hydraulic Motor & Displacement Pump Parts

Ref.	Torque	Ref.	Torque
	145-155 ft-lb (196.6 - 210.2 N•m)		140-160 in-lb (15.8 - 18.1 N•m)
	12-18 ft-lb (16.3 - 24.4 N•m)		70-80 ft-lb (94.9 - 108.5 N•m)

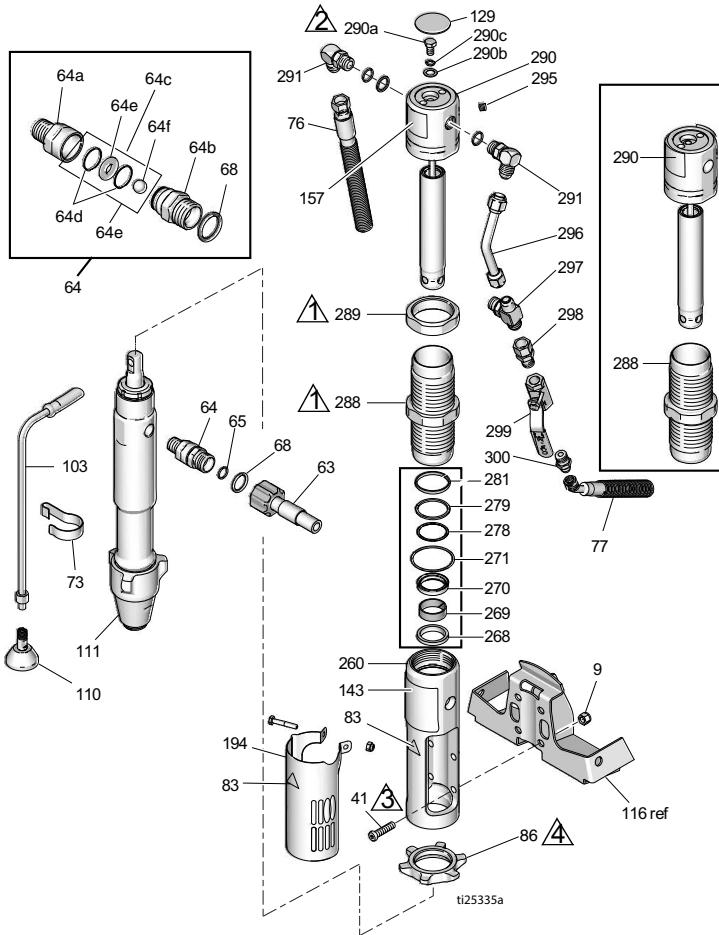

DutyMax EH/GH230/300 HD Standard Series

Hydraulic Motor & Displacement Pump Parts List

Ref.	Part	Description	Qty.	Ref.	Part	Description	Qty.
8	15F584	LABEL, ProConnect	1		17D065	LABEL, brand, front (EH300DI)	1
9	101566	NUT, lock	4		17D067	LABEL, brand, front (GH300DI)	1
33	189920	STRAINER, (1-11 1/2 npsm)	1				
41◆	107210	SCREW	4	157◆	15B804	LABEL, Graco	2
57	288344	CLAMP, pump	1	178	156698	PACKING, o-ring	1
58	105510	WASHER, lock, spring (hi-collar)	2	179	277377	COUPLER, pump	2
59	101550	SCREW, cap, sch	2	180	15H957	COVER, coupler	1
63	257908	HOSE, coupled	1	194	24X474	COVER, shield	1
64	24M611	KIT, check valve (includes 64a -64f)	1	260◆	15E243	MANIFOLD, adapter	1
64a	16N461	HOUSING, seat, check valve	1	268◆+	117739	WIPER, rod	1
64b	16N462	HOUSING, ball, check valve	1	269◆+	112342	BEARING, rod	1
64c	24M725	KIT, repair, check valve (includes 64d, 64e, 64f, 68)	1	270◆+	112561	PACKING, block	1
64d*		O-RING	2	271◆+	117283	PACKING, o-ring	1
64e*		SEAT, valve	1	278◆+	108014	PACKING, o-ring	1
64f*		BALL, ceramic	1	279◆+	178226	SEAL, piston	1
65	109450	PACKING, o-ring	1	281◆+	178207	BEARING, piston	1
68*	C20195	PACKING, o-ring	1	288◆	248991	SLEEVE, hydraulic	1
73	198542	CLIP, spring	1	289◆	15A726	NUT, jam	1
76	15K642	HOSE, hydraulic, return	1	290◆	288755	KIT, repair, trip rod (includes 129, 278, 279, 281, 282, 295)	1
77	15K641	HOSE, hydraulic, supply	1	290a◆	106276	SCREW, cap, hex head	1
83▲◆	192840	LABEL, warning	1	290b◆	155685	PACKING, o-ring	1
86	193394	NUT, retaining, GH230/300	1	290c◆	178179	WASHER, sealing	1
103	243993	HOSE, drain, Ultra hi-boy	1	291◆	117607	FITTING, elbow std thd	2
110	241920	DEFLECTOR, threaded	1	295◆	100139	PLUG, pipe	1
111	24W999	PUMP, displacement	1	296◆	15E596	TUBE, hydraulic, supply	1
129◆	15B063	LABEL, warning	1	297◆	117609	FITTING, tee, branch, str thd	1
143	17D061	LABEL, brand, front (EH230DI)	1	298	117328	FITTING, nipple, straight	1
		LABEL, brand, front (GH230DI)	1	299	117441	VALVE, ball	1
				300	116813	FITTING, nipple, hydraulic	1

▲ *Danger and Warning labels are available at no cost*

◆ *Included in Hydraulic Motor Repair Kit 248977 (EH/GH300).*

+ *Included in Seal Kit 246174*

* *Included in Check Valve Repair Kit 24M725*

DutyMax EH/GH230/300 HD Standard Series

DutyMax EH/GH230 HD Spray Gun & Hose Parts

Ref.	Part No.	Description	Qty.
202a	240797	HOSE, grounded, nylon; 3/8 in. ID; cpld 3/8-18 npsm; 50 ft (15 m); spring guards both ends	1
202b	241735	HOSE, grounded, nylon; 1/4 in. ID; cpld 1/4 npt(m) x 1/4 npsm(f); 3 ft (0.9m); spring guards both ends 3300 psi (227 bar, 22.7 MPa)	1
202c	241705	GUN, spray, texture, Includes RAC [®] Tip Guard and LTX531 Spray Tip Cylinder, See 308491 for parts	1
202d	159841	ADAPTER, 3/8 x 1/4 in. npt	1
202e	239663	SWIVEL, straight	1
202f	196178	ADAPTER, nipple	1

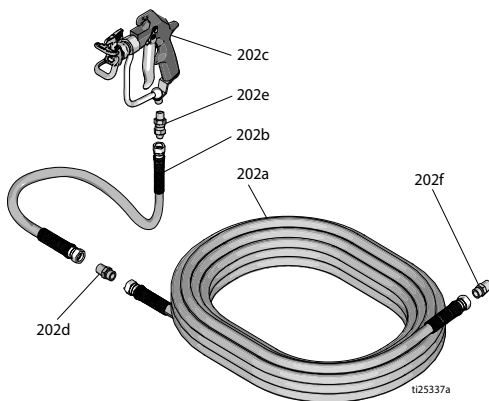

DutyMax EH/GH300 HD Spray Gun & Hose Parts

Ref.	Part No.	Description	Qty.
225a	159239	FITTING, nipple, pipe, rdcg	2
225b	191239	HOSE, cpld, 3/8 in. x 11 ft 10 in.	1
225d	245820	KIT, accessory, gun	1
225f	278499	HOSE, cpld, 1/2 in. x 50 ft, 3300 wp	1

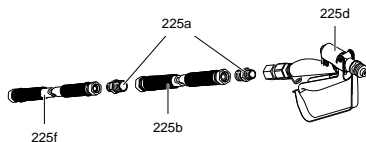

DutyMax DH230/EH/GH230/300 HD

DutyMax DH230/EH/GH230/300 HD ProContractor Series

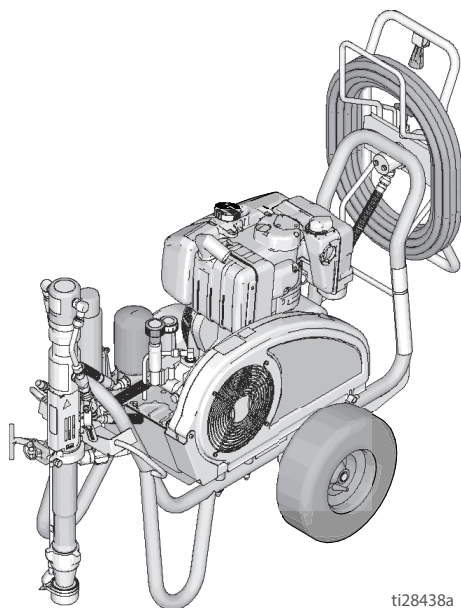

ti28438a

DutyMax DH230 HD

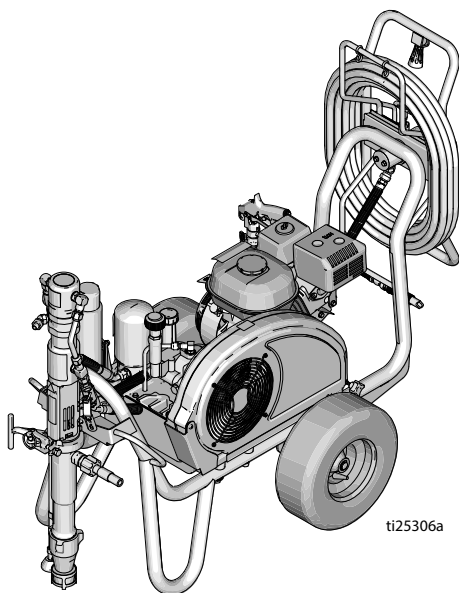



ti25306a

DutyMax EH/GH230/300 HD

DutyMax DH230/EH/GH230/300 HD

DH230/EH/GH230/300 HD Frame and Belt Guard Parts

Ref.	Torque	Ref.	Torque
	120-130 in-lb (13.6 - 14.7 N•m)		Inflate tires to 25-35 psi (1.7-2.4 bar)

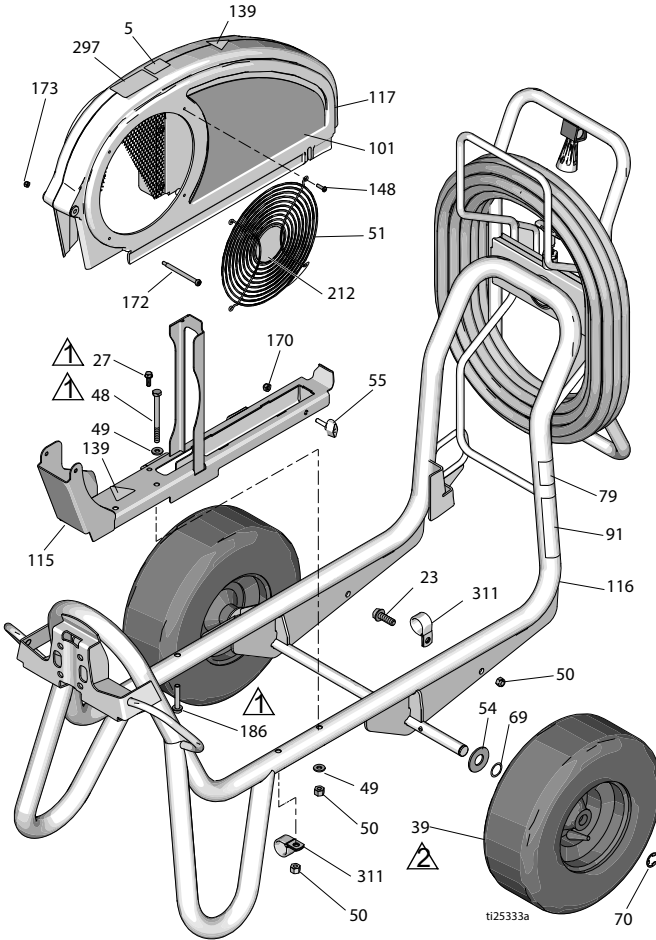

DutyMax DH230/EH/GH230/300 HD





Parts List

Ref.	Part	Description	Qty.	Ref.	Part	Description	Qty.
5	16D576	LABEL, made in USA with global component	1	17D044	LABEL, brand, side (GH230DI)	1	
23	110963	SCREW, cap, flange head	1	17D046	LABEL, brand, side (EH300DI)	1	
27	260212	SCREW, hex washer hd, thd form	1	17D048	LABEL, brand, side (GH300DI)	1	
39	119509	WHEEL, pneumatic	2	115	24M086	RAIL, belt guard, assy	1
48	867539	SCREW, cap, hex hd	2	116	17D108	FRAME, cart, weldment	1
49	100527	WASHER, plain	3	117	248973	GUARD, belt assembly, painted	1
50	110838	NUT, lock	2	139▲	16M768	LABEL, warning	2
51	117284	GRILL, fan guard	1	148	115477	SCREW, mach, torx pan hd	4
54	156306	WASHER, flat	2	170	102040	NUT, lock, hex	1
55	17D813	NUT, hand	1	172	119434	SCRWE, shoulder, skt hd	1
69	116038	WASHER, wave spring	2	173	116969	NUT, lock	1
70	120211	RING, retaining, e-ring	2	186	17D142	SCREW, hex washer hd	2
79▲	189246	LABEL, warning	1	212	16N398	LABEL, direction (EH/GH300DI)	1
91▲	194317	LABEL, warning, EN	1	297	17D033	LABEL, ProContractor	1
	16N948	LABEL, warning, ISO	1	311	128051	CLAMP	2
	17D947	LABEL, warning, multi-languages	1				
101	17D042	LABEL, brand, side (EH230DI)	1				
	17J339	LABEL, brand, side (DH230DI)	1				

▲Danger and Warning labels are available at no cost

DutyMax DH230/EH/GH230/300 HD

DutyMax EH230 HD Electric Motor Parts

Ref.	Torque	Ref.	Torque
	26-30 in-lb (2.9 - 3.4 N•m)		Apply Loctite 242
	215-235 in-lb (24.3 - 26.6 N•m)		55-62 in-lb (6.7 - 7.0N•m)

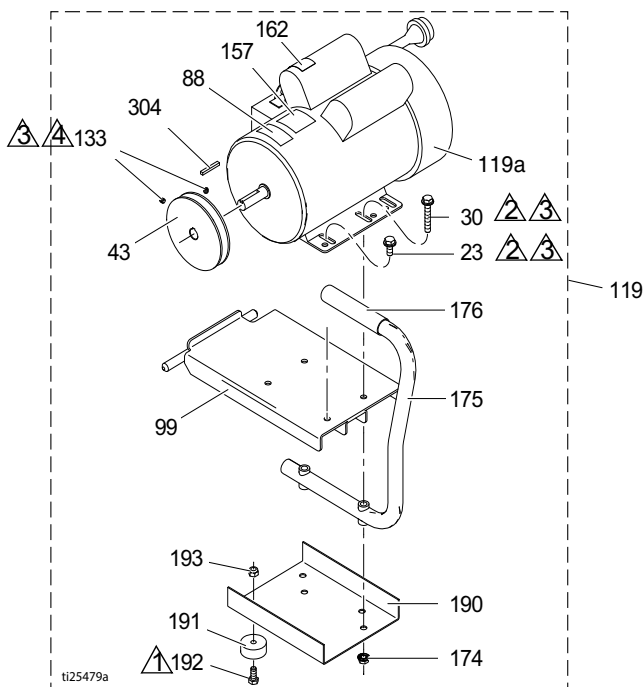

Ref.	Part	Description	Qty.	Ref.	Part	Description	Qty.
23	110963	SCREW, cap, flange head	2	133	100002	SCREW, set	2
30	114653	SCREW, cap, flange head	2	157	15B804	LABEL, Graco	2
43	15E588	PULLEY	1	162▲	189930	LABEL, warning	1
44	116914	BELT, V-Grip-notch (not shown)	1	174	110996	NUT, hex, flange head	4
88▲	15K616	LABEL, caution	1	175	246214	HANDLE, conversion	1
99	15E585	BRACKET, mounting, elec. motor	1	176	111700	GRIP, handle	1
119	248946	KIT, electric motor 3.0 hp (includes all parts listed on this page)	1	190	15F217	PLATE, isolator, bottom	1
119a	15E669	MOTOR, electric 3 HP, 230V AC	1	191	113817	BUMPER	4
				192	100057	SCREW, cap, hex hd	4
				193	111040	NUT, lock, insert, nylock, 5/16	4
				304	117632	KEY, square 3/16 x 1.25	1

▲Danger and Warning labels are available at no cost

DutyMax DH230/EH/GH230/300 HD

DutyMax DH230 HD Diesel Engine Parts

Ref.	Torque	Ref.	Torque
▲1	120-130 in-lb (13.6 - 14.7 N•m)	▲3	Apply Loctite 242
▲2	58-62 in-lb (6.6 - 7.0 N•m)	▲4	65-85 in-lb (7.3 - 9.6 N•m)

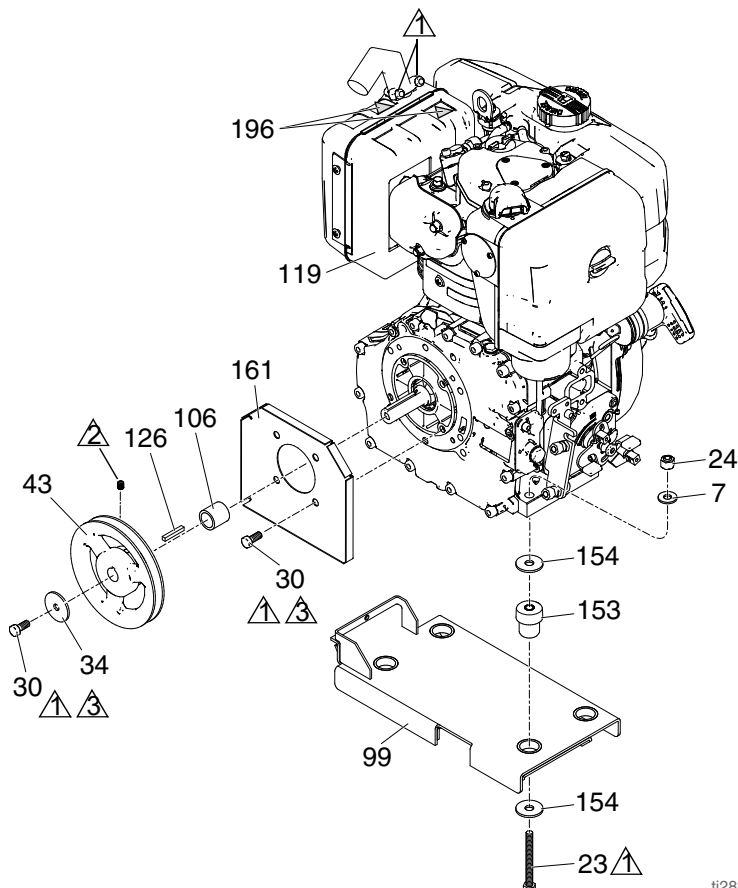

ti28390a

Ref.	Part	Description	Qty.	Ref.	Part	Description	Qty.
7	100023	WASHER, flat	4	126	17L826	KEY, square 3/16 x 1.125	1
23	110385	SCREW, cap, hex head	4	153	15E888	DAMPENER, engine mount	4
24	110838	NUT, lock	4	154	108851	WASHER, plain	8
30	108842	SCREW, cap, flange head	5	161	17K215	SHIELD, engine shaft	1
34	112717	WASHER	1	196▲	17K859	LABEL, safety, hot surface	2
43	17L825	PULLEY, 6 inch	1			BELT, V-Grip-notch (not shown)	1
99	17H148	BRACKET, mounting, engine, Diesel	1				
106	17L823	SLEEVE, engine shaft	1				
119	17H150	ENGINE, Diesel	1				

▲Danger and Warning labels are available at no cost

DutyMax DH230/EH/GH230/300 HD

DutyMax GH230 HD Gasoline Engine Parts

Ref.	Torque	Ref.	Torque
▲1	120-130 in-lb (13.6 - 14.7 N·m)	▲3	Apply Loctite 242
▲2	58-62 in-lb (6.6 - 7.0 N·m)		

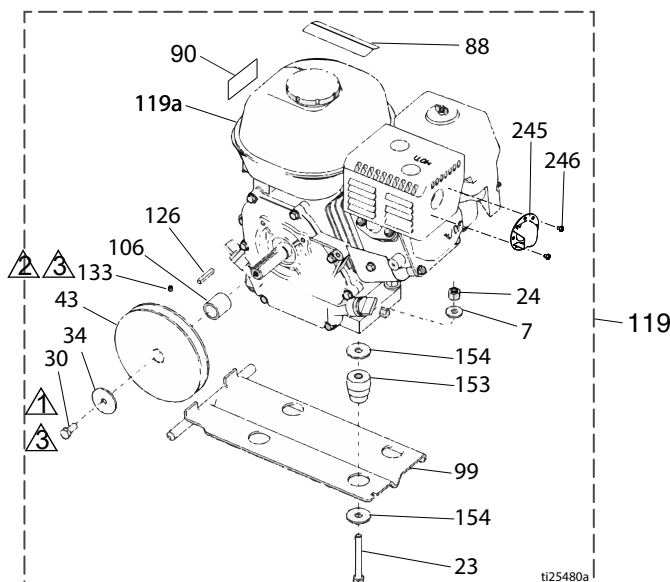

Ref.	Part	Description	Qty.	Ref.	Part	Description	Qty.
7	100023	WASHER, flat	4	119	248944	KIT, gas engine 6.5 hp (includes all parts listed on this page)	2
23	113664	SCREW, cap, hex hd	4	119a	116298	ENGINE, 6.5 gas	1
24	110838	NUT, lock	4	126	117632	KEY, square, 3/16 x 1.25	1
30	108842	SCREW, cap, hex hd	2	133	100002	SCREW, set	1
34	112717	WASHER	1	153	15E888	DAMPENER, motor mount	4
43	116908	PULLEY, 5.50 in.	1	154	108851	WASHER, plain	8
44	119433	BELT, V-Grip-notch (not shown)	1	245	128099	DEFLECTOR, exhaust	1
50	110838	NUT, lock	4	246	128101	SCREW, tapping	2
88▲	194126	LABEL, warning	1	▲Danger and Warning labels are available at no cost			
90▲	16Y720	LABEL, warning, ISO engine	1				
99	15F157	BRACKET, mounting, engine	1				
106	15B314	SLEEVE, motor shaft	1				

DutyMax DH230/EH/GH230/300 HD

DutyMax EH300 HD Electric Motor Parts

Ref.	Torque	Ref.	Torque
▲1	26-30 in-lb (2.9 - 3.4 N•m)	▲3	Apply Loctite 242
▲2	215-235 in-lb (24.3 - 26.6 N•m)	▲4	58-62 in-lb (6.6 - 7.0 N•m)

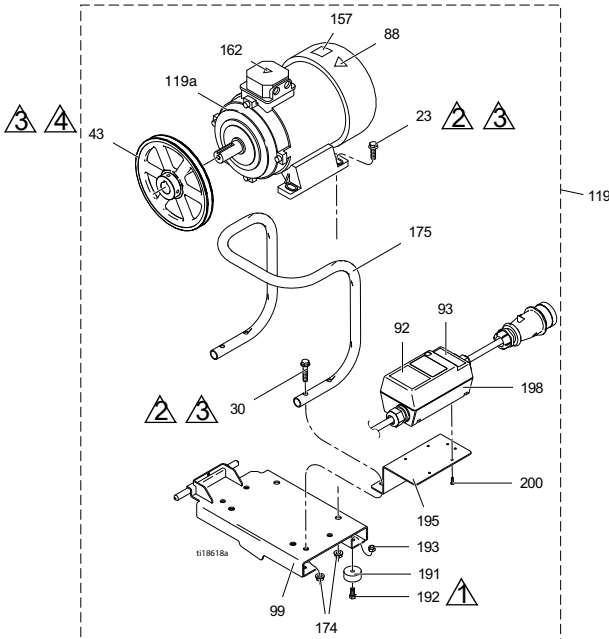

Ref.	Part	Description	Qty.	Ref.	Part	Description	Qty.
23	111193	SCREW, cap, flange head	4	162▲	189930	LABEL, caution	1
30	116780	SCREW, hex, hd, flanged	4	174	112958	NUT, hex, flanged	8
43	125811	PULLEY, cast iron, 8.75 in	1	175	16M473	TUBE, handle, conversion	1
88▲	15K616	LABEL, caution	1	191	113817	BUMPER	4
92	16N399	LABEL, motor switch box on-off	1	192	100057	SCREW, cap, hex hd	4
93	16N400	LABEL, red light indicator	1	193	111040	NUT, lock, insert, nylock, 5/16	4
99	16M467	BRACKET, mounting, motor, EH300	1	195	16M474	BRACKET, motor starter	1
119	24M669	KIT, motor (includes all parts listed on this page)	1	198	24N064	STARTER, motor assembly	1
119a	24N019	MOTOR, elec., 400 VAC, 50 Hz, 7.3 hp	1	200	119236	SCREW, plastite	4

▲Danger and Warning labels are available at no cost

DutyMax DH230/EH/GH230/300 HD

DutyMax GH300 HD Gasoline Engine Parts



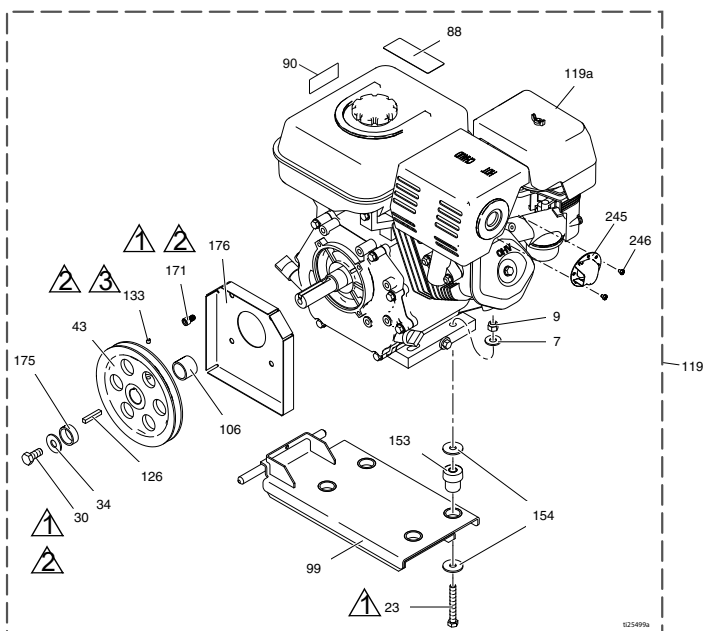



Ref.	Torque	Ref.	Torque
▲1	120-130 in-lb (13.6 - 14.7 N•m)	▲3	58-62 in-lb (6.6 - 7.0 N•m)
▲2	Apply Loctite 242		



Ref.	Part	Description	Qty.	Ref.	Part	Description	Qty.
7	100132	WASHER, flat	4	119a	803900	ENGINE, gasoline, 9.0 hp (Honda)	1
	100023	WASHER, flat (Vanguard)	4		24P301	ENGINE, gasoline, 9.0 hp (China only)	1
9	110838	NUT, lock	4		248945V	ENGINE, gasoline, 10 hp (Vanguard, California compliant)	1
23	106212	SCREW, cap, hex hd	4	126	119484	KEY, parallel, square	1
	113664	SCREW, cap, hex hd (Vanguard)	4	133	100002	SCREW, set	1
30	116645	SCREW, cap, hex head	1	153	195515	DAMPENER, motor mount	4
34	100696	WASHER, wrought	1		15E888	DAMPENER, motor mount (Vanguard)	4
43	119401	PULLEY	1	154	108851	WASHER, plain	8
44	119432	BELT, V-Grip-notch (not shown)	1	171	C20010	SCREW, cap, socket head	4
88▲	194126	LABEL, warning	1	175	15E764	SPACER, shaft, engine	1
90▲	16Y720	LABEL, warning, ISO engine	1	176	15E973	SHIELD, engine shaft	1
99	15E583	BRACKET, mounting, engine	1	245	124145	DEFLECTOR, exhaust	1
106	15E586	SLEEVE, shaft, engine	1	246	128101	SCREW, tapping	3
119	248945	KIT, gas engine 9.0 hp (includes all parts listed on this page)	1	▲Danger and Warning labels are available at no cost			
119	25P354	KIT, gas engine 9.0 hp (China Only)	1				

DutyMax DH230/EH/GH230/300 HD

DutyMax Reservoir & Filter Parts

Ref.	Torque	Ref.	Torque
	58-62 in-lb (6.6 - 7.0 N•m)		15-25 in-lb (1.7 - 2.8 N•m)
	Apply Loctite 242		Apply Loctite 277
	90-110 in-lb (10.2 - 12.4 N•m)		110-120 in-lb (12.4 - 13.6 N•m)
	355-395 in-lb (40.1 - 44.6 N•m)		

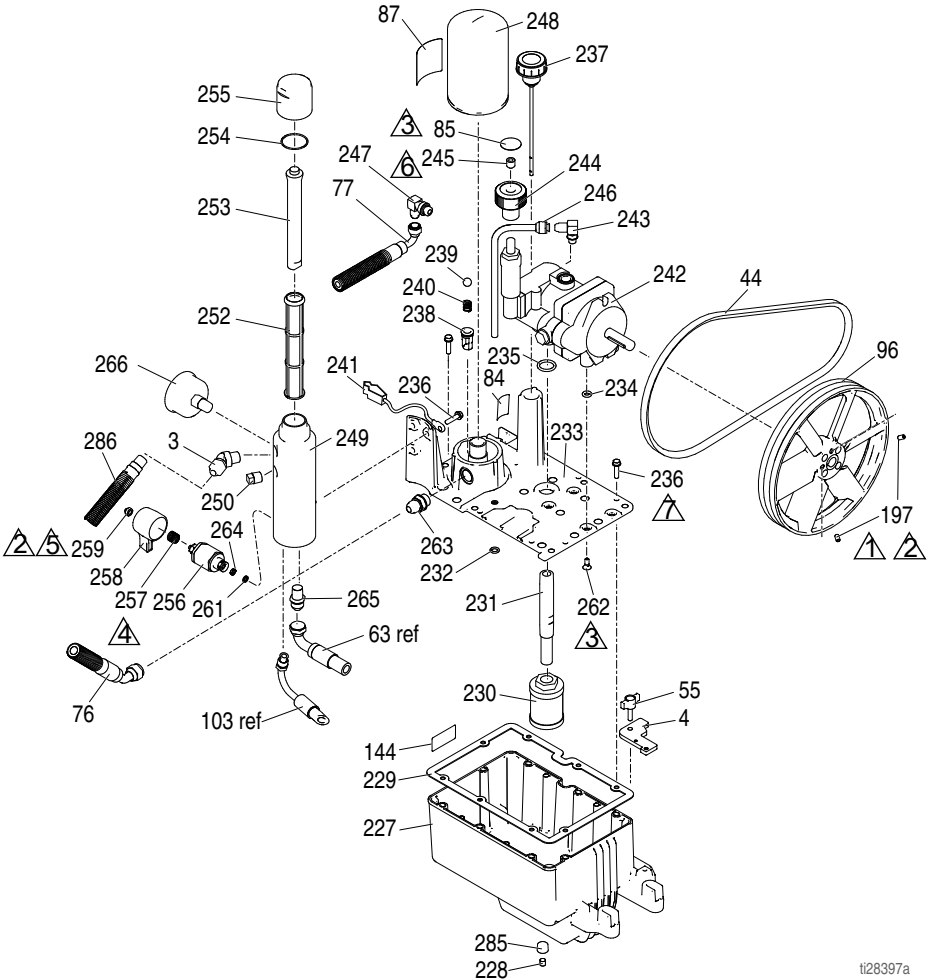

t28397a

DutyMax DH230/EH/GH230/300 HD





DutyMax Reservoir & Filter Parts List

Ref.	Part	Description	Qty.	Ref.	Part	Description	Qty.
3	161889	FITTING, outlet	1	242	249003	PUMP, hydraulic	1
4	15E476	BRACKET, retainer, motor	1	246178	PUMP, hydraulic (DH230DI)	1	
44	116914	BELT, V, AX42 (EH230DI)	1	243	110792	FITTING, elbow, male, 90°	1
	119433	BELT, V, AX41 (GH230DI)		244	15B438	KNOB, pressure	1
	125834	BELT, V, AX48 (EH300DI)	1	245	117560	SCREW, set, socket head	1
	17L829	BELT, V, AX43 (DH230DI)	1	246	246167	TUBE, hydraulic, case drain	1
	119432	BELT, V, AX44 (GH300DI)	1	247	116829	FITTING, elbow, hydraulic	1
55	17D813	NUT, hand	1	248	246173	FILTER, oil, spin on	1
84	198585	LABEL, hydraulic fluid, GH	1	249	15E599	HOUSING, filter	1
85	15A464	LABEL, control	1	250	15G331	PLUG, pipe	1
87	189892	LABEL, Graco	1	252	244067	FILTER, fluid	1
96	15E410	PULLEY, fan	1	253	15C766	TUBE, diffusion	1
144	15K440	LABEL, brand, GH/EH cooling	1	254	117285	PACKING, o-ring	1
				255	15C765	CAP, filter	1
				256*	287879	VAVLE, drain, assy	1
				257*	114708	SPRING, comp	1
				258*	15G563	HANDLE, valve	1
197	120087	SCREW, set, 1/4 x 1/2	2	259*	116424	NUT, cap	1
227	15J513	TANK, reservoir, blue	1	261*	193710	SEAL, seat, valve	1
228	101754	PLUG, pipe	1	262	117471	SCREW, mach, hex flat head	4
229	120604	GASKET, reservoir	1	263	120184	FITTING, hydraulic	1
230	116919	FILTER	1	264*	193709	SEAT, valve	1
231	15E587	TUBE, suction	1	265	121311	FITTING, connector	1
232	154594	PACKING, o-ring	1	266	868015	GAUGE	1
233	15M056	COVER, reservoir	1	285	116618	MAGNET	1
234	107188	PACKING, o-ring	4	286	17D266	HOSE, coupled, 3/8 x 73.5	1
235	156401	PACKING, o-ring	1	299	290079	LABEL, ground warning, English	1
236	119426	SCREW, mach, hex washer hd	11		16Y633	LABEL, ground warning, Chinese	1
237	120726	CAP, breather, filter	1				
238	198841	RETAINER, ball, pressure bypass	1				
239	100084	BALL, metallic	1				
240	116967	SPRING, compression	1				
241	237686	WIRE, ground assembly w clamp	1				

* Included in Drain Valve Kit 245103

DutyMax DH230/EH/GH230/300 HD

Hydraulic Motor & Displacement Pump Parts

Ref.	Torque	Ref.	Torque
	145-155 ft-lb (196.6 - 210.2 N•m)		140-160 in-lb (15.8 - 18.1 N•m)
	12-18 ft-lb (16.3 - 24.4 N•m)		90-110 in-lb (10.2 - 12.4 N•m)

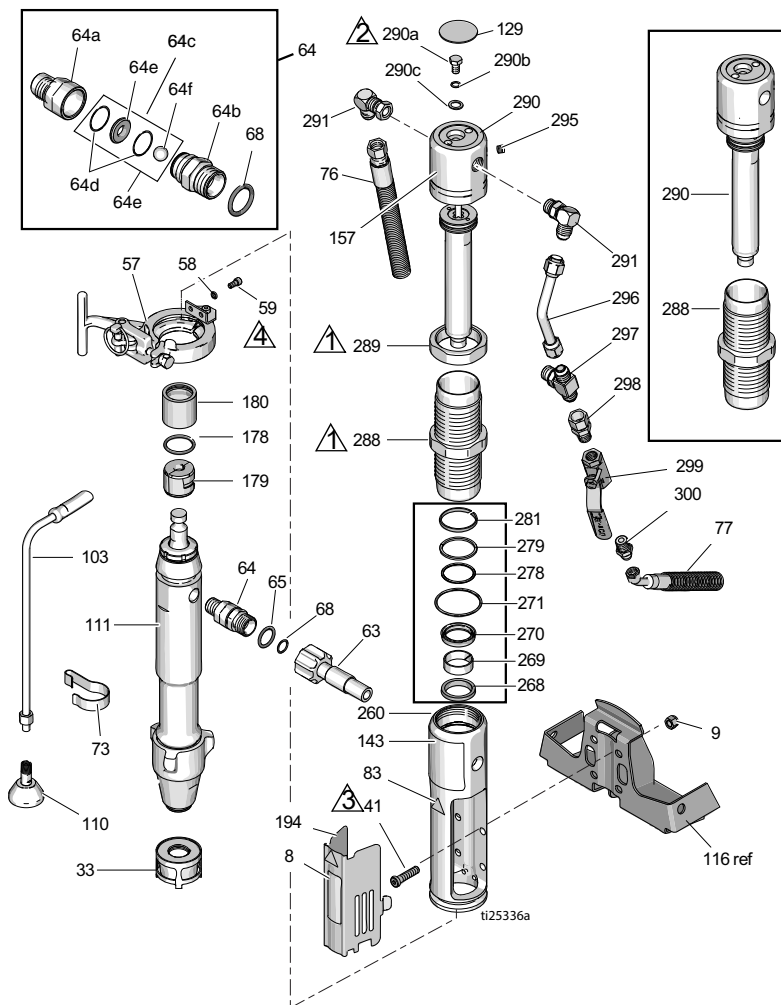

DutyMax DH230/EH/GH230/300 HD

Hydraulic Motor & Displacement Pump Parts List

Ref.	Part	Description	Qty.	Ref.	Part	Description	Qty.
8	15F584	LABEL, ProConnect	1	157◆	15B804	LABEL, Graco	2
9	101566	NUT, lock	4	178	156698	PACKING, o-ring	1
33	15V573	STRAINER		179	277377	COUPLER, pump	2
41◆	107210	SCREW	4	180	15H957	COVER, coupler	1
57	288344	CLAMP, pump	1	194	16M749	COVER, shield	1
58	105510	WASHER, lock, spring (hi-collar)	2	260◆	15J279	MANIFOLD, adapter	1
				268◆+	117739	WIPER, rod	1
59	101550	SCREW, cap	2	269◆+	112342	BEARING, rod	1
63	257908	HOSE, coupled	1	270◆+	112561	PACKING, block	1
64	24M611	KIT, check valve (includes 64a -64f)	1	271◆+	117283	PACKING, o-ring	1
64a	16N461	HOUSING, seat, check valve	1	278◆+	108014	PACKING, o-ring	1
64b	16N462	HOUSING, ball, check valve	1	279◆+	178226	SEAL, piston	1
				281◆+	178207	BEARING, piston	1
64c	24M725	KIT, repair, check valve (includes 64d, 64e, 64f, 68)	1	288◆	248991	SLEEVE, hydraulic, cylinder	1
				289◆	15A726	NUT, jam	1
64d*		O-RING	2	290◆	288737	KIT, repair, Trip Rod (includes 129, 278, 279, 281, 282, 295)	1
64e*		SEAT, valve	1	290a◆	106276	SCREW, cap, hex head	1
64f*		BALL, ceramic	1	290b◆	155685	PACKING, o-ring	1
65	109450	PACKING, o-ring	1	290c◆	178179	WASHER, sealing	1
68*	C20195	PACKING, o-ring	1	291◆	117607	FITTING, elbow std thd	2
73	198542	CLIP, spring	1	295◆	100139	PLUG, pipe	1
76	15K642	HOSE, hydraulic, return	1	296◆	15E596	TUBE, hydraulic, supply	1
77	15K641	HOSE, hydraulic, supply	1	297◆	117609	FITTING, tee, branch, str thd	1
83▲◆	15H108	LABEL, warning	1	298	117328	FITTING, nipple, straight	1
103	243993	HOSE, drain, Ultra hi-boy	1	299	117441	VALVE, ball	1
				300	116813	FITTING, nipple, hydraulic	1
110	241920	DEFLECTOR, threaded	1				
111	24X001	PUMP, displacement	1				
129◆▲	15B063	LABEL, warning, hot surface	1				
143		LABEL, brand, front	1				
	17J340	(DH230DI)	1				
	17D061	(EH230DI)	1				
	17D063	(GH230DI)	1				
	17D065	(EH300DI)	1				
	17D067	(GH300DI)	1				

▲ *Danger and Warning labels are available at no cost*

◆ *Included in Hydraulic Motor Repair Kit, 288760*
+ *Included in Seal Kit 246174*

* *Included in Check Valve Repair Kit 24M725*

DutyMax DH230/EH/GH230/300 HD

DutyMax DH/EH/GH230 HD Sprayer - Spray Gun & Hose

Ref.	Part No.	Description	Qty.
202a	240797	HOSE, grounded, nylon; 3/8 in. ID; cpld 3/8-18 npsm; 50 ft (15 m); spring guards both ends	2
202b	241735	HOSE, grounded, nylon; 1/4 in. ID; cpld 1/4 npt(m) x 1/4 npsm(f); 3 ft (0.9m); spring guards both ends 3300 psi (227 bar, 22.7 MPa)	1
202c	241705	GUN, spray, texture, Includes RAC® Tip Guard and LTX531 Spray Tip Cylinder, See 308491 for parts	1
202d	159841	ADAPTER, 3/8 x 1/4 in. npt	1
202e	189018	SWIVEL, straight	1
202f	162485	ADAPTER, nipple	2

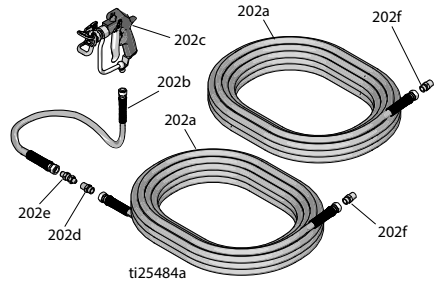



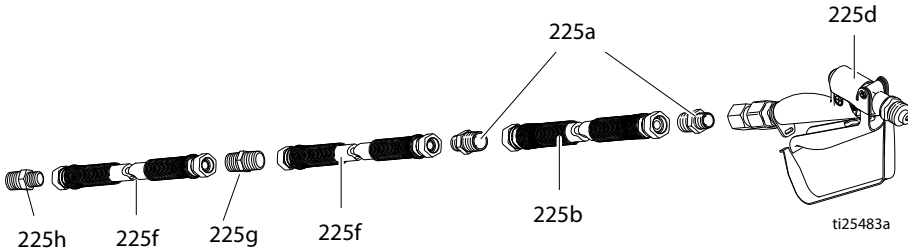

DutyMax EH/GH™ 300 HD Sprayer - Spray Gun and Hose



Ref.	Part No.	Description	Qty.
225a	159239	FITTING, nipple, pipe, rdcg	3
225b	191239	HOSE, cpld, 3/8 in. x 11 ft 10 in.	1
225d	245820	KIT, accessory, gun	1
225f	278499	HOSE, cpld, 1/2 in. x 50 ft, 3300 wp	2
225g	158491	FITTING, nipple	1
225h	159239	FITTING, nipple	1

DutyMax DH230/EH/GH230/300 HD

ProContractor Series Only Hose Reel Parts

Ref.	Torque	Ref.	Torque
	120-130 in-lb (13.6 - 14.7 N•m)		130-150 in-lb (14.7 - 16.9 N•m)
	25-35 ft-lb (33.9 - 47.5 N•m)		Apply Loctite 277

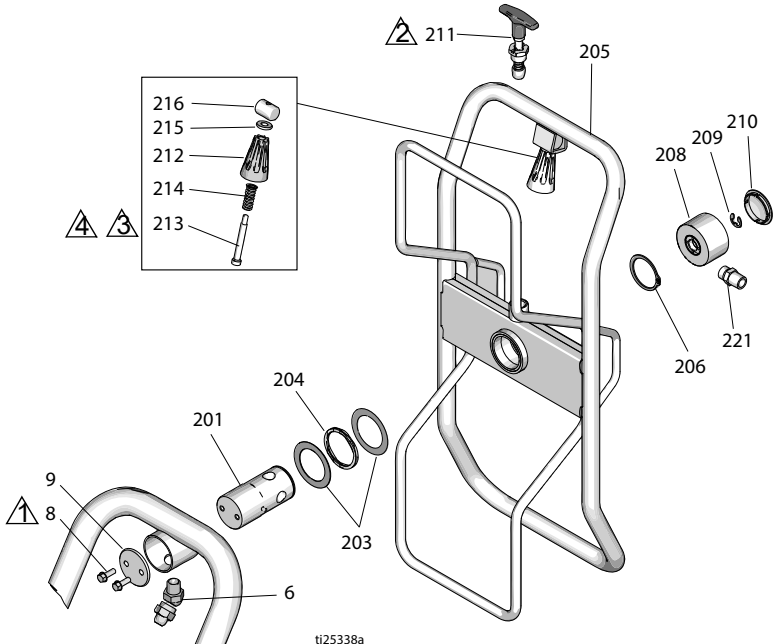

ti25338a

Ref.	Part	Description	Qty.	Ref.	Part	Description	Qty.
6	161889	FITTING, union swivel 45°	1	211	24E400	PIN, pop, lock out	1
8	260212	SCREW, hex washer hd	2	212	278085	HANDLE, swivel	1
9	16C975	PLATE, pivot mount	1	213	122518	SCREW, shoulder, sch	1
201	24E016	TUBE, hose reel, pivot hd	1	214	122542	SPRING	1
203	122607	WASHER, flat	1	215	122669	WASHER, flat	1
204	122534	SPRING, wave	1	216	15X618	NUT, swivel, handle	1
205	24B691	REEL, hose	1	221	162485	ADAPTER (models 24W942, 24W962, DH230DI)	1
206	122524	RING, retaining, external	1	116756	ADAPTER (models 24W966, 24W968)	1	
208	24B248	CAP, swivel, complete	1	159239	ADAPTER (models 24W966, 24W968)	1	
209	122347	RING, retaining, external	1				
210	122787	CAP	1				

Technical Data

Technical Data

DutyMax EH230 HD Standard Series		
	US	Metric
Maximum fluid working pressure	3300 psi	22.8 MPa, 228 bar
Hydraulic reservoir capacity	1.25 gallons	4.75 liters
Motor	3.0 HP	2.2 kW
Voltage, Amperage Frequency Phase	220 VAC, 15.0 A, 50 Hz, 1 phase	220 VAC, 15.0 A 50 Hz, 1 phase
Maximum tip size	0.039	
Maximum free-flow delivery	1.56 gpm	5.9 l/min
Hose connection	3/8 npsm (f)	
Cycles per gallon	80	21.1
Sound Levels (Measured at maximum normal load conditions)		
Engine HP	3.0	
Sound pressure	80 dBa	
Sound power	95	
Inlet/Outlet Sizes		
Fluid inlet size in.	1 npt (m)	
Fluid outlet size in.	3/8 npt (m)	
Weight		
	197 lb.	89 kg
Width		
	26.5 in.	67 cm
Length (Handle bar retracted)		
	47.7 in.	121 cm
Height (Handle bar retracted)		
	35.5 in.	90 cm

DutyMax EH300 HD Standard Series		
	US	Metric
Maximum fluid working pressure	3300 psi	22.8 MPa, 228 bar
Hydraulic reservoir capacity	1.25 gallons	4.75 liters
Motor	7.5 HP	5.5 kW
Voltage, Amperage Frequency Phase	400 VAC, 11.0 A, 50 Hz, 3 phase	400 VAC, 11.0 A 50 Hz, 3 phase
Maximum tip size	0.057	
Maximum free-flow delivery	3.0 gpm	11.3 l/min
Hose connection	1/2 npsm (f)	
Cycles per gallon	52	13.7
Sound Levels (Measured at maximum normal load conditions)		
Engine HP	7.4	
Sound pressure	80 dBa	
Sound power	95	
Inlet/Outlet Sizes		
Fluid inlet size in.	1 npt (m)	
Fluid outlet size in.	1/2 npt (m)	
Weight		
	236 lb.	107 kg
Width		
	26.5 in.	67 cm
Length (Handle bar retracted)		
	47.7 in.	121 cm
Height (Handle bar retracted)		
	35.5 in.	90 cm

Maximum back fuse rating for EH300 HD:

Fuse type aM: 63A

Fuse type gL: 80 A

NOTE: Under voltage release coil in motor starter for EH300 HD will not energize if voltage is less than 85% of listed voltage in Technical Data table.

Under voltage release coil in motor starter for EH300 HD will de-energize and sprayer will stop if voltage drops to 85% of rated nominal voltage. Voltage will need to be increased and sprayer will need to be restarted.

NOTE: To operate the EH300 HD (24M056) sprayer with a generator, the generator must be sized for 5 kW output (minimum).

Technical Data

DutyMax GH230 HD Standard Series

	US	Metric
Maximum fluid working pressure	3300 psi	22.8 MPa, 228 bar
Hydraulic reservoir capacity	1.25 gallons	4.75 liters
Maximum hydraulic pressure	1855 psi	12.8 MPa, 128 bar
Engine	200 cc (6.5 HP)	
Maximum tip size	0.053	
Maximum free-flow delivery	2.35 gpm	8.9 l/min
Hose connection	3/8 npsm (m)	
Noise (dBa)		
Maximum sound pressure	96 dBa	
Maximum sound power	110 dBa	
Inlet/Outlet Sizes		
Fluid inlet size	1 5/16-12 UN-ZA	
Fluid outlet size	3/8 npt (f)	
Weight		
	199 lbs.	90 kg
Width		
	26.5 in.	67 cm
Length		
	47.7 in.	121 cm
Height (Handle bar retracted)		
	35.5 in.	90 cm

DutyMax GH300 HD Standard Series		
	US	Metric
Maximum fluid working pressure	3300 psi	22.8 MPa, 228 bar
Hydraulic reservoir capacity	1.25 gallons	4.75 liters
Maximum hydraulic pressure	1855 psi	12.8 MPa, 128 bar
Engine	270 cc / 305 cc (9.0 HP / 10.0 HP)	
Maximum tip size	0.057	
Maximum free-flow delivery	3.0 gpm	11.4 l/min
Hose connection	3/8 npsm (m)	
Noise (dBa)		
Maximum sound pressure	96 dBa	
Maximum sound power	110 dBa	
Inlet/Outlet Sizes		
Fluid inlet size	1 5/16-12 UN-ZA	
Fluid outlet size	3/8 npt (f)	
Weight		
	218 lbs	99 kg
Width		
	26.5 in.	67 cm
Length		
	47.7 in.	121 cm
Height (Handle bar retracted)		
	35.5 in.	90 cm

Technical Data

DutyMax EH230 HD ProContractor Series

	US	Metric
Maximum fluid working pressure	3300 psi	22.8 MPa, 228 bar
Hydraulic reservoir capacity	1.25 gallons	4.75 liters
Engine	3.0 HP	2.2 kW
Voltage, Amperage Frequency Phase	220 VAC, 15.0 A, 50 Hz, 1 phase	220 VAC, 15.0 A 50 Hz, 1 phase
Maximum tip size	0.039	
Maximum free-flow delivery	1.56 gpm	5.9 l/min
Hose connection	3/8 npsm (f)	
Cycles per gallon	80	21.1
Sound Levels (Measured at maximum normal load conditions)		
Engine HP	3.0	
Sound pressure	80 dBa	
Sound power	95	
Inlet/Outlet Sizes		
Fluid inlet size in.	1 npt (m)	
Fluid outlet size in.	3/8 npt (m)	
Weight		
	227 lbs.	103 kg
Width		
	26.5 in.	67 cm
Length		
	52 in.	132 cm
Height		
	39 in.	99 cm

DutyMax EH300 HD ProContractor Series		
	US	Metric
Maximum fluid working pressure	3300 psi	22.8 MPa, 228 bar
Hydraulic reservoir capacity	1.25 gallons	4.75 liters
Engine	7.5 HP	5.5 kW
Voltage, Amperage Frequency Phase	400 VAC, 11.0 A, 50 Hz, 3 phase	400 VAC, 11.0 A 50 Hz, 3 phase
Maximum tip size	0.057	
Maximum free-flow delivery	3.0 gpm	11.3 l/min
Hose connection	1/2 npsm (f)	
Cycles per gallon	52	13.7
Sound Levels (Measured at maximum normal load conditions)		
Engine HP	7.4	
Sound pressure	80 dBA	
Sound power	95	
Inlet/Outlet Sizes		
Fluid inlet size in.	1 npt (m)	
Fluid outlet size in.	1/2 npt (m)	
Weight		
	266 lbs	120.6 kg
Width		
	26.5 in.	67 cm
Length		
	52 in.	132 cm
Height		
	39 in.	99 cm

Technical Data

DutyMax DH230/GH230 HD ProContractor Series

	US	Metric
Maximum fluid working pressure	3300 psi	22.8 MPa, 228 bar
Hydraulic reservoir capacity	1.25 gallons	4.75 liters
Maximum hydraulic pressure	1855 psi	12.8 MPa, 128 bar
Engine		
DH230	350 cc (6.7 HP)	
GH230	200 cc (6.5 HP)	
Maximum tip size	0.053	
Maximum free-flow delivery	2.35 gpm	8.9 l/min
Hose connection	3/8 npsm (m)	
Noise (dBa)		
Maximum sound pressure		
DH230	91 dBa	
GH230	96 dBa	
Maximum sound power		
DH230	106 dBa	
GH230	110 dBa	
Inlet/Outlet Sizes		
Fluid inlet size	1 5/16-12 UN-ZA	
Fluid outlet size	3/8 npt (f)	
Weight		
DH230	266 lb.	121 kg
GH230	229 lb.	104 kg
Width		
	26.5 in.	67 cm
Length		
	52 in.	132 cm
Height (Hose Reel Up)		
	39 in.	99 cm
OEM Kit		
Paint/Hydraulic pressure ratio	1.78:1	
Max cycle rate	145 cpm	
User Supplied Input		
Max hydraulic pressure	1855 psi	12.8 MPa, 128 bar
Hydraulic flow required in free-flow	6.60 gpm	25.0 l/min
Unit Output		
Max fluid Pressure	3300 psi	22.8 MPa, 228 bar
Max flow	3.0 gpm	11.4 l/min
Weight		
	35 lb.	15.9 kg
Width		
	8.94 in.	227 mm
Depth		
	5.38 in.	137 mm
Height		
	28.80 in.	732 mm

DutyMax GH300 HD ProContractor Series

	US	Metric
Maximum fluid working pressure	3300 psi	22.8 MPa, 228 bar
Hydraulic reservoir capacity	1.25 gallons	4.75 liters
Maximum hydraulic pressure	1855 psi	12.8 MPa, 128 bar
Engine	270 cc / 305 cc (9.0 HP / 10.0 HP)	
Maximum tip size	0.057	
Maximum free-flow delivery	3.0 gpm	11.4 l/min
Hose connection	3/8 npsm (m)	
Noise (dBA)		
Maximum sound pressure	96 dBA	
Maximum sound power	110 dBA	
Inlet/Outlet Sizes		
Fluid inlet size	1 5/16-12 UN-ZA	
Fluid outlet size	3/8 npt (f)	
Weight		
	248 lb.	112 kg
Width		
	26.5 in.	67 cm
Length		
	52 in.	132 cm
Height (Hose Reel Up)		
	39 in.	99 cm
OEM Kit		
Paint/Hydraulic pressure ratio	1.78:1	
Max cycle rate	145 cpm	
User Supplied Input		
Max hydraulic pressure	1855 psi	12.8 MPa, 128 bar
Hydraulic flow required in free-flow	6.60 gpm	25.0 l/min
Unit Output		
Max fluid Pressure	3300 psi	22.8 MPa, 228 bar
Max flow	3.0 gpm	11.4 l/min
Weight		
	35 lb.	15.9 kg
Width		
	8.94 in.	227 mm
Depth		
	5.38 in.	137 mm
Height		
	28.80 in.	732 mm

All Models:

Basic Sprayer Wetted Parts:

Zinc and nickel-plated carbon steel, stainless steel, PTFE, acetal, chrome plating, leather, V-Max UHMWPE, aluminum, tungsten carbide, ceramic, nylon

GH230/300 OEM 24W299

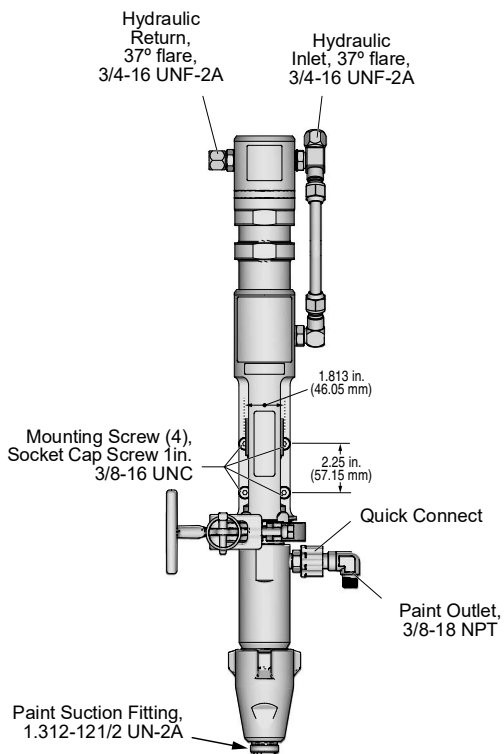

624313b

Graco Standard Warranty

Graco warrants all equipment referenced in this document which is manufactured by Graco and bearing its name to be free from defects in material and workmanship on the date of sale to the original purchaser for use. With the exception of any special, extended, or limited warranty published by Graco, Graco will, for a period of twelve months from the date of sale, repair or replace any part of the equipment determined by Graco to be defective. This warranty applies only when the equipment is installed, operated and maintained in accordance with Graco's written recommendations.

This warranty does not cover, and Graco shall not be liable for general wear and tear, or any malfunction, damage or wear caused by faulty installation, misapplication, abrasion, corrosion, inadequate or improper maintenance, negligence, accident, tampering, or substitution of non-Graco component parts. Nor shall Graco be liable for malfunction, damage or wear caused by the incompatibility of Graco equipment with structures, accessories, equipment or materials not supplied by Graco, or the improper design, manufacture, installation, operation or maintenance of structures, accessories, equipment or materials not supplied by Graco.

This warranty is conditioned upon the prepaid return of the equipment claimed to be defective to an authorized Graco distributor for verification of the claimed defect. If the claimed defect is verified, Graco will repair or replace free of charge any defective parts. The equipment will be returned to the original purchaser transportation prepaid. If inspection of the equipment does not disclose any defect in material or workmanship, repairs will be made at a reasonable charge, which charges may include the costs of parts, labor, and transportation.

THIS WARRANTY IS EXCLUSIVE, AND IS IN LIEU OF ANY OTHER WARRANTIES, EXPRESS OR IMPLIED, INCLUDING BUT NOT LIMITED TO WARRANTY OF MERCHANTABILITY OR WARRANTY OF FITNESS FOR A PARTICULAR PURPOSE.

Graco's sole obligation and buyer's sole remedy for any breach of warranty shall be as set forth above. The buyer agrees that no other remedy (including, but not limited to, incidental or consequential damages for lost profits, lost sales, injury to person or property, or any other incidental or consequential loss) shall be available. Any action for breach of warranty must be brought within two (2) years of the date of sale.

GRACO MAKES NO WARRANTY, AND DISCLAIMS ALL IMPLIED WARRANTIES OF MERCHANTABILITY AND FITNESS FOR A PARTICULAR PURPOSE, IN CONNECTION WITH ACCESSORIES, EQUIPMENT, MATERIALS OR COMPONENTS SOLD BUT NOT MANUFACTURED BY GRACO. These items sold, but not manufactured by Graco (such as electric motors, switches, hose, etc.), are subject to the warranty, if any, of their manufacturer. Graco will provide purchaser with reasonable assistance in making any claim for breach of these warranties.

In no event will Graco be liable for indirect, incidental, special or consequential damages resulting from Graco supplying equipment hereunder, or the furnishing, performance, or use of any products or other goods sold hereto, whether due to a breach of contract, breach of warranty, the negligence of Graco, or otherwise.

FOR GRACO CANADA CUSTOMERS

The Parties acknowledge that they have required that the present document, as well as all documents, notices and legal proceedings entered into, given or instituted pursuant hereto or relating directly or indirectly hereto, be drawn up in English. Les parties reconnaissent avoir convenu que la rédaction du présente document sera en Anglais, ainsi que tous documents, avis et procédures judiciaires exécutés, donnés ou intentés, à la suite de ou en rapport, directement ou indirectement, avec les procédures concernées.

Graco Information

For the latest information about Graco products, visit www.graco.com.

For patent information, see www.graco.com/patents.

TO PLACE AN ORDER, contact your Graco distributor or call 1-800-690-2894 to identify the nearest distributor.

All written and visual data contained in this document reflects the latest product information available at the time of publication.

Graco reserves the right to make changes at any time without notice.

Original instructions. This manual contains English. MM 334606

Graco Headquarters: Minneapolis

International Offices: Belgium, China, Japan, Korea

GRACO INC. AND SUBSIDIARIES • P.O. BOX 1441 • MINNEAPOLIS MN 55440-1441 • USA

Copyright 2014, Graco Inc. All Graco manufacturing locations are registered to ISO 9001.

www.graco.com

Revision J, August 2022