

Therm-O-Flow[®] 20

334129W

EN

For applying hot melt sealant and adhesive materials from 20 Liter (5 Gallon) pails. For professional use only.

Not approved for use in European explosive atmosphere locations.



Important Safety Instructions

Read all warnings and instructions in this manual and in related manuals. Save these instructions.

Maximum Operating Temperature 400°F (204°C)
See page 7 for model information.

See **Technical Specifications**, page 112, for maximum working pressures.

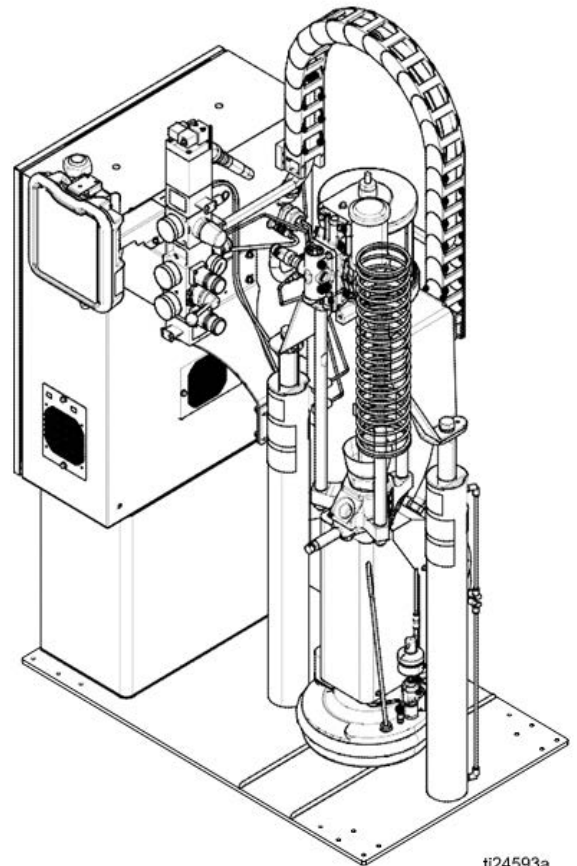

ti24593a



Intertek

3143485

Certified to

CSA STD C22.2 No. 88

Conforms to

UL STD 499

PROVEN QUALITY. LEADING TECHNOLOGY.

Contents

Related Manuals	3	Repair	48
Warnings	4	Replace Wipers	48
Models	7	Replace Platen RTD	49
Component Identification	8	Separate the Air Motor and Pump	50
Integrated Air Controls	9	Remove Platen	52
Electrical Control Enclosure	10	Replace Heater Band and Pump RTD	52
Advanced Display Module (ADM)	11	Replace MZLP Fuse	53
Screen Components	13	Replace MZLP	54
Overview	14	Replace MZLP Daughter Card	55
Air and Fluid Hoses	14	Replace AWB	56
Heat Control Zone	14	Replace Power Supply	56
MZLP-1	14	Replace Fan	57
Setup	15	Replace Transformer	58
Unpack	15	Update Software	60
Location Requirements	15	Electrical Schematics	61
Install System	15	230V, 3 Phase/60Hz	61
Mechanical Setup	16	400V, 3 Phase/50Hz	62
Install Heated Hose	17	400-600VV, 3 Phase/60Hz	63
Connect Multiple Devices	18	AWB	64
Connect Power	19	MZLP#1	65
Grounding	20	MZLP#2, MZLP#3 Pump Heaters	66
Connect Secondary System	20	MZLP#2, MZLP#3, Overtemp	67
Check Sensor Resistance	21	MZLP Zones	68
Check Heater Resistance	22	Parts	69
Select ADM Settings	23	Therm-O-Flow 20 Supply Unit	70
Connect PLC (Hard Wired Interface Version) ..	25	Therm-O-Flow 20 Supply Unit	71
Operation	28	Air Control Assembly	72
Purge System	28	Electrical Module	73
Load Material	29	Electrical Control Module Parts	75
Heat Up System	30	Electrical Panel	77
Prime Pump	31	230V	77
Prime System	33	400V	77
Setback Mode	33	Transformer	77
Pressure Relief Procedure	34	Electrical Panel Parts	79
Stop Controls	35	Merkur 2200, 23:1 Pump Modules	80
Shutdown	36	Merkur 2200, 23:1 Pump Modules	81
Schedule	36	Merkur 3400, 36:1 Pump Modules	82
Change Pail	37	Merkur 3400, 36:1 Pump Modules	83
Troubleshooting	39	NXT 6500, 70:1 Pump Modules	84
Light Tower (Optional)	39	NXT 6500, 70:1 Pump Modules	85
Error Codes	40	Pump Shield	86
Ram Troubleshooting	46	President, 15:1 Pump Module	87
Heated Pump Troubleshooting	47	Heated Platens	89
Air Motor Troubleshooting	47		

Accessories and Kits 91

 Wiper Kits 91

 Applicators and Dispense Valves 91

 CGM Installation Kit, 25C994 91

 Flow Control and Manifolds 91

 Accessory Extension Cables 91

 Light Tower Kit 24W589 92

 Tie Rod Kits 24V750 and 24V754 92

 Overtemperature Jumper 16Y727 92

 Heated Hoses and Fittings 93

 8 Channel Upgrade Kit, 24V755 95

 8 Zone Upgrade Kit Installation 96

 12 Channel Upgrade Kit, 24V756 97

 12 Zone Upgrade Kit Installation 98

Appendix A - ADM 98

 General Operation 98

 ADM Power 98

 Screen Navigation 98

 Enable, Disable Heating System 98

 Icons 99

 Operation Screens 100

 Setup Screens 102

Appendix B - USB Data 107

 Download 107

 Access Files 107

 Upload 107

 USB Logs 108

 System Settings File 108

 System Language File 109

 Create Custom Language Strings 109

Dimensions 110

 Ram Mounting and Clearance 110

 15:1 111

Technical Specifications 112









Graco Standard Warranty 114

Related Manuals

Manual	Description
334130	Therm-O-Flow 200, Instructions-Parts
3A5186	Communications Gateway Module Therm-O-Flow
306982	President® Air Motor, Instructions-Parts
311238	NXT® Air Motor, Instructions-Parts
3A1211	Saniforce® Air Motor, Instructions-Parts
334127	Check-Mate® 800 Pump, Repair-Parts
334128	Check-Mate® 800 Throat Seal Repair Kit, Repair-Parts
307431	Displacement Pump, Carbon Steel, Instructions-Parts
334198	55 Gallon, 16 Gallon, and 5 Gallon Ram Modules, Repair - Parts
3A4241	Heated Hose, Instructions-Parts
309160	Heated Hose, Instructions-Parts
309196	Wiper Kits, Repair-Parts
310538	Air-Operated Dispense Valves, Instruc- tions-Parts
311209	Top Feed and Bottom Feed Hot Melt Dis- pense Guns, Instructions-Parts
334201	Air Controls, Repair Kit
334131	Manual Bulldog/Senator Tie Rod Kit
334132	Manual NXT Tie Rod kit

Warnings

The following warnings are for the setup, use, grounding, maintenance, and repair of this equipment. The exclamation point symbol alerts you to a general warning and the hazard symbols refer to procedure-specific risks. When these symbols appear in the body of this manual or on warning labels, refer back to these Warnings. Product-specific hazard symbols and warnings not covered in this section may appear throughout the body of this manual where applicable.

 WARNING	
	<p>BURN HAZARD</p> <p>Equipment surfaces and fluid that is heated can become very hot during operation. To avoid severe burns:</p> <ul style="list-style-type: none"> Do not touch hot fluid or equipment.
	<p>SPLATTER HAZARD</p> <p>Hot or toxic fluid can cause serious injury if splashed in the eyes or on skin. During blow off of platen, splatter may occur.</p> <ul style="list-style-type: none"> Use minimum air pressure when removing platen from drum.
 	<p>MOVING PARTS HAZARD</p> <p>Moving parts can pinch, cut or amputate fingers and other body parts.</p> <ul style="list-style-type: none"> Keep clear of moving parts. Do not operate equipment with protective guards or covers removed. Pressurized equipment can start without warning. Before checking, moving, or servicing equipment, follow the Pressure Relief Procedure and disconnect all power sources.
 	<p>ELECTRIC SHOCK HAZARD</p> <p>This equipment must be grounded. Improper grounding, setup, or usage of the system can cause electric shock.</p> <ul style="list-style-type: none"> Turn off and disconnect power at main switch before disconnecting any cables and before servicing or installing equipment. Connect only to grounded power source. All electrical wiring must be done by a qualified electrician and comply with all local codes and regulations.
	<p>TOXIC FLUID OR FUMES HAZARD</p> <p>Toxic fluids or fumes can cause serious injury or death if splashed in the eyes or on skin, inhaled, or swallowed.</p> <ul style="list-style-type: none"> Read MSDSs to know the specific hazards of the fluids you are using. Store hazardous fluid in approved containers, and dispose of it according to applicable guidelines.



WARNING



THERMAL EXPANSION HAZARD

Fluids subjected to heat in confined spaces, including hoses, can create a rapid rise in pressure due to the thermal expansion. Over-pressurization can result in equipment rupture and serious injury.

- Open a valve to relieve the fluid expansion during heating.
- Replace hoses proactively at regular intervals based on your operating conditions.



SKIN INJECTION HAZARD

High-pressure fluid from dispensing device, hose leaks, or ruptured components will pierce skin. This may look like just a cut, but it is a serious injury that can result in amputation. **Get immediate surgical treatment.**

- Engage trigger lock when not dispensing.
- Do not point dispensing device at anyone or at any part of the body.
- Do not put your hand over the fluid outlet.
- Do not stop or deflect leaks with your hand, body, glove, or rag.
- Follow the **Pressure Relief Procedure** when you stop dispensing and before cleaning, checking, or servicing equipment.
- Tighten all fluid connections before operating the equipment.
- Check hoses and couplings daily. Replace worn or damaged parts immediately.



FIRE AND EXPLOSION HAZARD

Flammable fumes, such as solvent and paint fumes, in work area can ignite or explode. To help prevent fire and explosion:

- Use equipment only in well ventilated area.
- Eliminate all ignition sources; such as pilot lights, cigarettes, portable electric lamps, and plastic drop cloths (potential static arc).
- Keep work area free of debris, including solvent, rags and gasoline.
- Do not plug or unplug power cords, or turn power or light switches on or off when flammable fumes are present.
- Ground all equipment in the work area. See **Grounding** instructions.
- Use only grounded hoses.
- Hold gun firmly to side of grounded pail when triggering into pail. Do not use pail liners unless they are antistatic or conductive.
- **Stop operation immediately** if static sparking occurs or you feel a shock. Do not use equipment until you identify and correct the problem.
- Keep a working fire extinguisher in the work area.





WARNING



EQUIPMENT MISUSE HAZARD

Misuse can cause death or serious injury.



- Do not operate the unit when fatigued or under the influence of drugs or alcohol.
- Do not exceed the maximum working pressure or temperature rating of the lowest rated system component. See **Technical Data** in all equipment manuals.
- Use fluids and solvents that are compatible with equipment wetted parts. See Technical Data in all equipment manuals. Read fluid and solvent manufacturer's warnings. For complete information about your material, request MSDS from distributor or retailer.
- Do not leave the work area while equipment is energized or under pressure.
- Turn off all equipment and follow the **Pressure Relief Procedure** when equipment is not in use.
- Check equipment daily. Repair or replace worn or damaged parts immediately with genuine manufacturer's replacement parts only.
- Do not alter or modify equipment. Alterations or modifications may void agency approvals and create safety hazards.
- Make sure all equipment is rated and approved for the environment in which you are using it.
- Use equipment only for its intended purpose. Call your distributor for information.
- Route hoses and cables away from traffic areas, sharp edges, moving parts, and hot surfaces.
- Do not kink or over bend hoses or use hoses to pull equipment.
- Keep children and animals away from work area.
- Comply with all applicable safety regulations.



PERSONAL PROTECTIVE EQUIPMENT

Wear appropriate protective equipment when in the work area to help prevent serious injury, including eye injury, hearing loss, inhalation of toxic fumes, and burns. This protective equipment includes but is not limited to:

- Protective eyewear, and hearing protection.
- Respirators, protective clothing, and gloves as recommended by the fluid and solvent manufacturer.

Models

The system ID label containing the model number can be found on the side of the control panel. See FIG. 1 page 8. The model number stamped on your system ID label defines the equipment in the following categories:

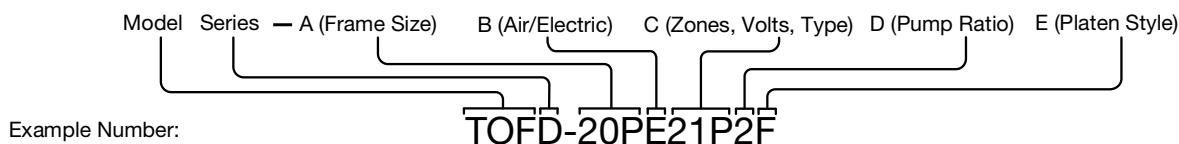

Code A	Frame Size
20P	5 Gallon (20 Liter)
Code B	Air/Electric
A	Air control only
E	Air and Electric
Code C	Zones, Volts, Type
11P	4 Zones, 230 V, Primary
11S	4 Zones, 230 V, Secondary
12P	4 Zones, 400 V/N, Primary
12S	4 Zones, 400 V/N, Secondary
13P	4 Zones, 400 V, Primary
13S	4 Zones, 400 V, Secondary
14P	4 Zones, 480 V, Primary
14S	4 Zones, 480 V, Secondary
15P	4 Zones, 600 V, Primary
15S	4 Zones, 600 V, Secondary
21P	8 Zones, 230 V, Primary
21S	8 Zones, 230 V, Secondary
22P	8 Zones, 400 V/N, Primary
22S	8 Zones, 400 V/N, Secondary
23P	8 Zones, 400 V, Primary
23S	8 Zones, 400 V, Secondary
24P	8 Zones, 480 V, Primary
24S	8 Zones, 480 V, Secondary

25P	8 Zones, 600 V, Primary
25S	8 Zones, 600 V, Secondary
31P	12 Zones, 230 V, Primary
31S	12 Zones, 230 V, Secondary
32P	12 Zones, 400 V/N, Primary
32S	12 Zones, 400 V/N, Secondary
33P	12 Zones, 400 V, Primary
33S	12 Zones, 400 V, Secondary
34P	12 Zones, 480 V, Primary
34S	12 Zones, 480 V, Secondary
35P	12 Zones, 600 V, Primary
35S	12 Zones, 600 V, Secondary
NNN	None
Code D	Pump Ratio
1	23:1 CF (Carbon-Filled)
2	36:1 CF
3	70:1 CF
4	23:1 GF (Glass-Filled)
5	36:1 GF
6	70:1 GF
7	15:1 PTFE
Code E	Platen Style
S	Smooth Bottom (No Fin)
F	Standard Finned Bottom

Note: the series letter designation in the model number on the system I.D. label is used to differentiate between older models and newer models that have updates that can effect operation or maintenance of the system. Notes have been added to this manual to emphasize these differences.

Component Identification

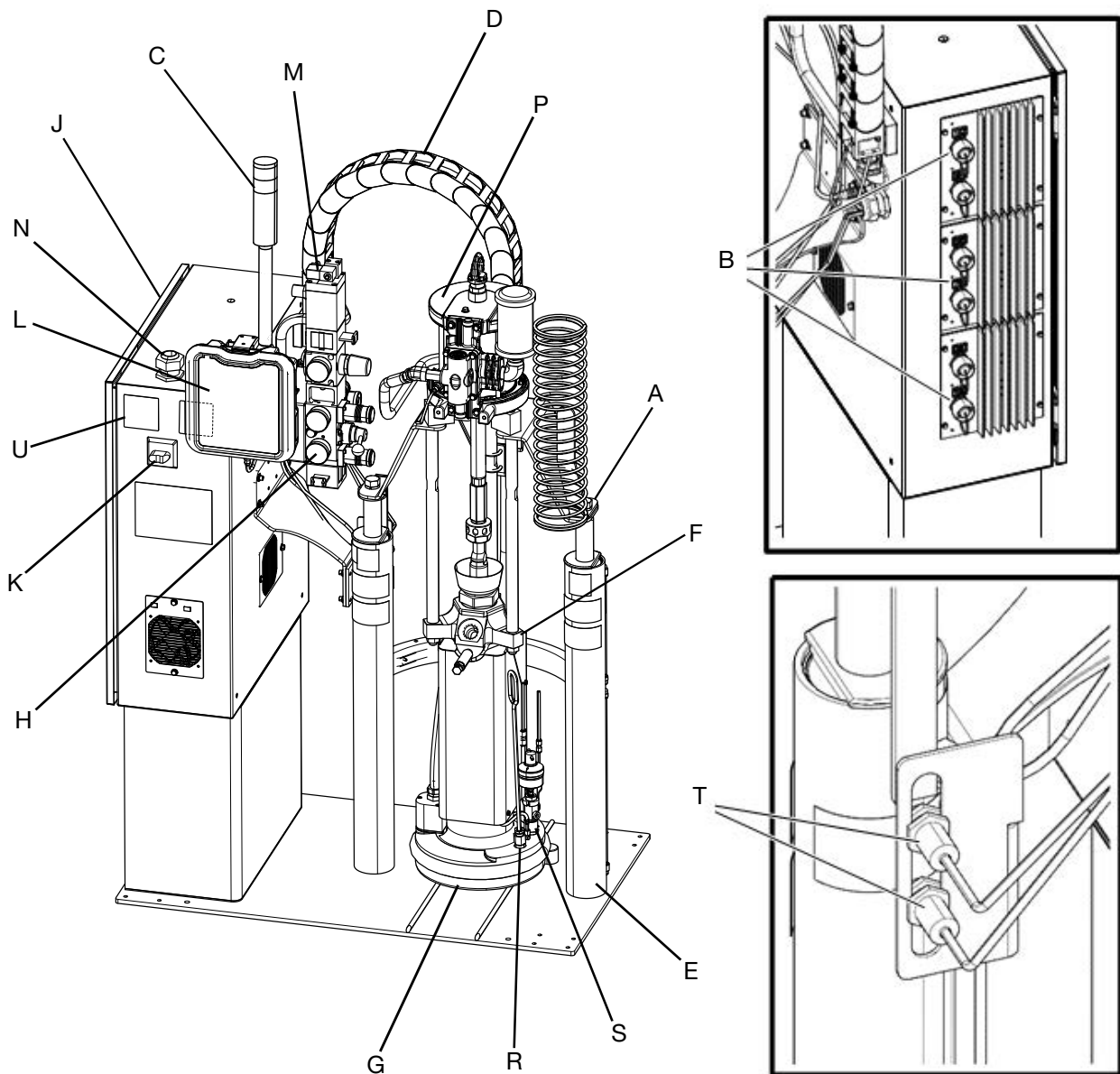

ti24594a

FIG. 1: TOF 20

Key:

- | | | | |
|---|--|---|--|
| A | Lift Strap Positions | K | Main Power Switch (can be locked in the open position) |
| B | Multi-Zone Low Power Temperature Control Module (MZLP) | L | ADM |
| C | Light Tower | M | Air Motor Solenoid |
| D | Cable Track | N | Electrical Power Input |
| E | Ram | P | Air Motor |
| F | Heated Pump | R | Ram Plate Bleed Stick |
| G | Heated Platen | S | Drum Blow Off Valve (behind ram plate bleed stick) |
| H | Integrated Air Controls (3/4 in npt inlet) | T | Drum Low and Empty Sensors |
| J | Electrical Control Panel | U | System ID and Service Labels |

Integrated Air Controls

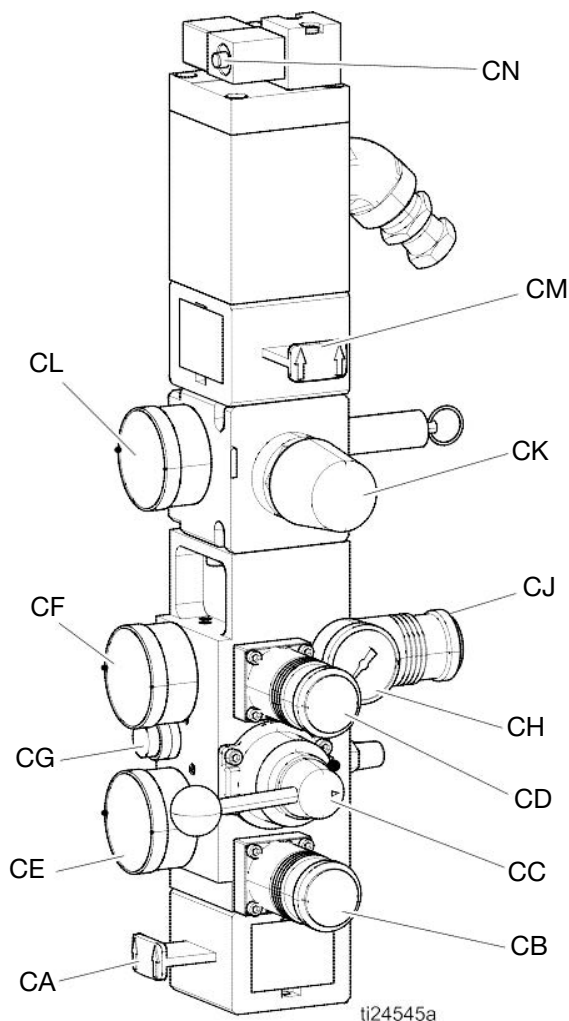

FIG. 2: Integrated Air Controls

Key:

- | | |
|--|--|
| <p>CA Main Air Slider Valve
Turns air on and off to the entire system. When closed, the valve relieves pressure downstream. Can be locked in the closed position.</p> <p>CB Ram Down Air Regulator
Controls the ram down pressure.</p> <p>CC Ram Director Valve
Controls the ram direction.</p> <p>CD Ram Up Air Regulator
Controls the ram up pressure.</p> <p>CE Ram Down Air Gauge
Displays the ram down pressure.</p> <p>CF Ram Up Air Gauge
Displays the ram up pressure.</p> <p>CG Blowoff Button
Turns air on and off to push the platen out of an empty drum.</p> | <p>CH Blowoff Pressure Gauge
Displays the blowoff pressure.</p> <p>CJ Blowoff Air Regulator
Controls platen blowoff pressure.</p> <p>CK Air Motor Air Regulator
Controls the air pressure to the motor.</p> <p>CL Air Motor Pressure Gauge
Displays the air pressure to the motor.</p> <p>CM Air Motor Slider Valve
Turns air on and off to the air motor. When closed, the valve relieves air trapped between it and the motor. Push the valve in to shut off air. Can be locked in the closed position.</p> <p>CN Air Motor Solenoid Valve
Turns air on and off to the air motor when system stopped on the ADM. When closed, the valve relieves air trapped between it and the motor.</p> |
|--|--|

Electrical Control Enclosure

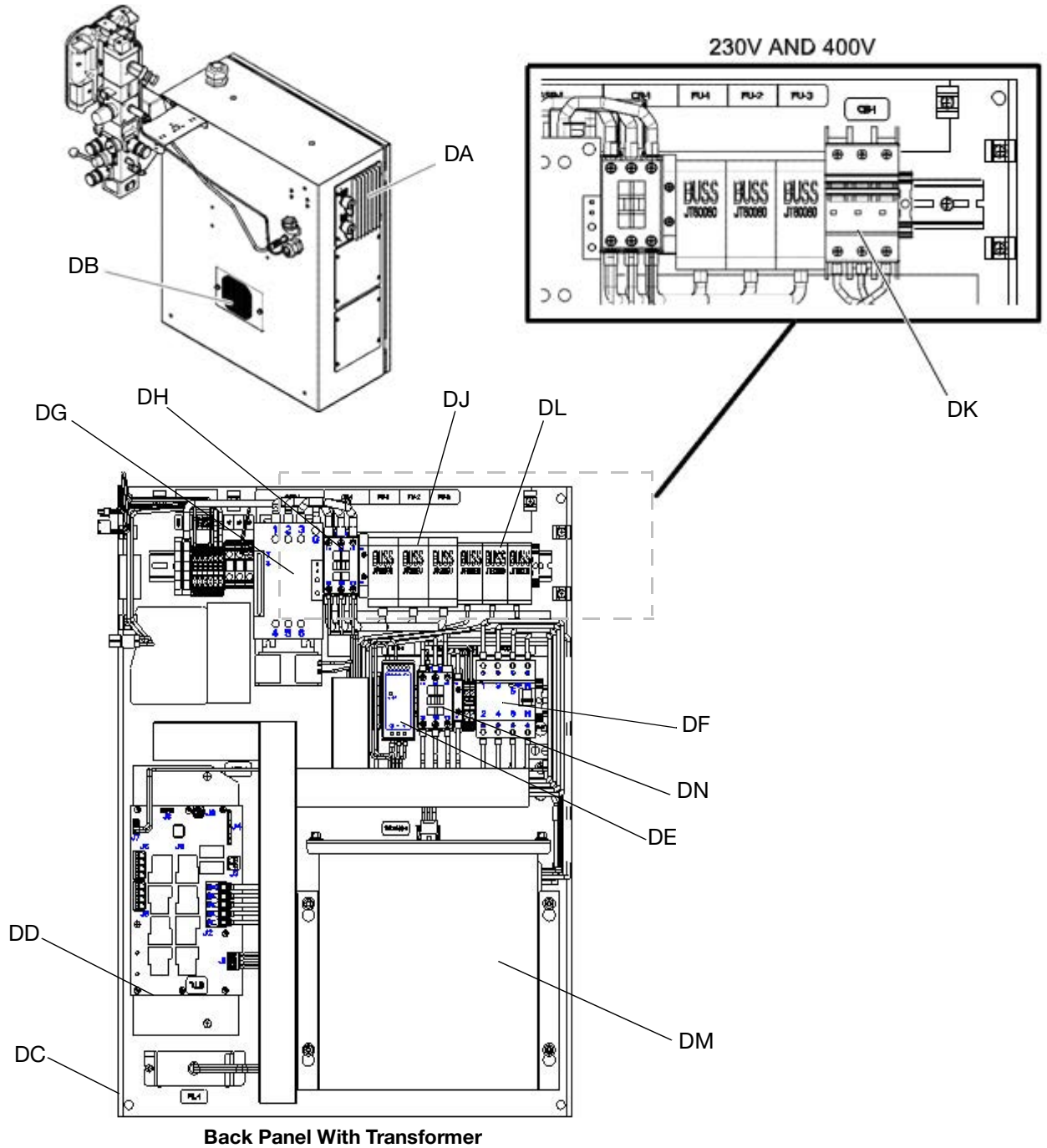

FIG. 3: Electrical Enclosure

Key:

- DA Multi-Zone Low Power Temperature Control Module (MZLP)
- DB Ventilation Grill
- DC Electrical Control Panel
- DD Automatic Wiring Board (AWB)
- DE Power Supply (24V)
- DF Residual Current Device (GFI), 63A

- DG Platen SSR (65A)
- DH Platen Contractor
- DJ Platen Fuse
- DK Transformer Circuit Breaker
- DL Transformer Fuse
- DM Transformer
- DN System Contactor

Advanced Display Module (ADM)

The ADM display shows graphical and text information related to setup and spray operations. For details on the display and individual screens, see **Appendix A - ADM**, page 98.

Use the USB port on the ADM to download or upload data. For more information about the USB data, see **Appendix B - USB Data**, page 107.

NOTICE
To prevent damage to the softkey buttons, do not press buttons with sharp objects such as pens, plastic cards, or fingernails.

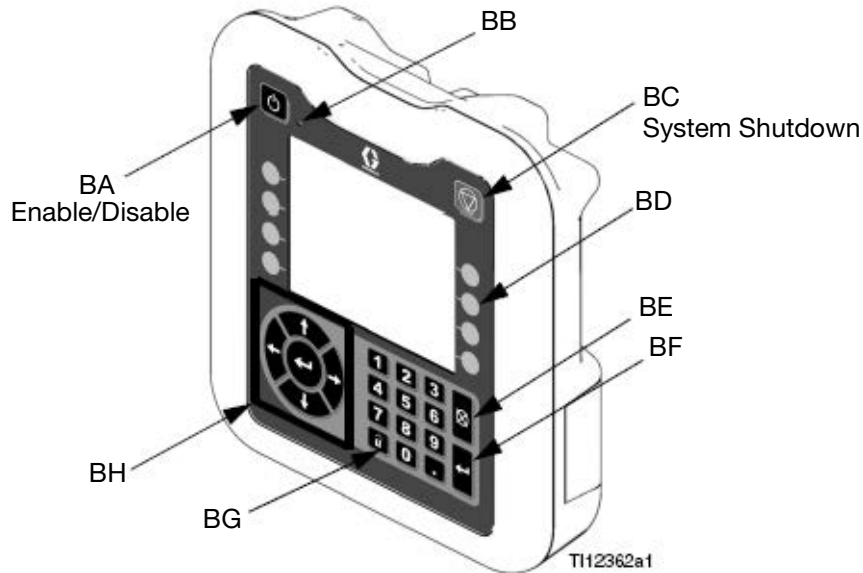

FIG. 4: Front View

Key	Function
BA	Heating system and Pump Enable/Disable
BB	System status indicator (LED)
BC	Stop all system processes
BD	Defined by icon next to softkey
BE	Abort current operation
BF	Accept change, acknowledge error, select item, toggle selected item
BG	Toggle between Operation and Setup screens
BH	Navigate within a screen or to a new screen

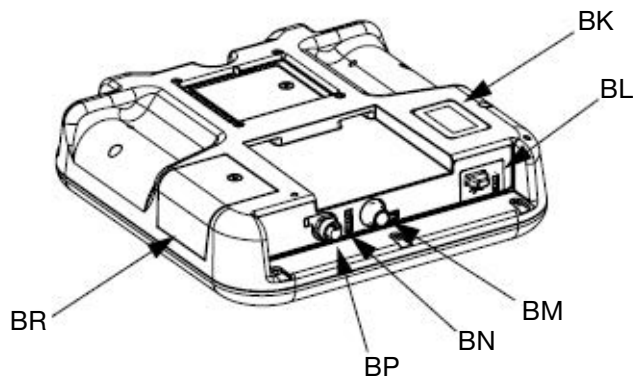



FIG. 5: Back View

BK	Part Number and Identification Label
BL	USB Interface
BM	CAN Cable Connection (Power Supply and Communication)
BN	Module Status LEDs
BP	Light Tower (Optional)
BR	Software Token Access Panel

Table 1 ADM LED Status Descriptions

LED	Conditions	Description
System Status 	Green Solid	Run Mode, System On
	Green Flashing	Setup Mode, System On
	Yellow Solid	Run Mode, System Off
USB Status (BL)	Green Flashing	Data recording in progress
	Yellow Solid	Downloading information to USB
	Green and Yellow Flashing	ADM is busy, USB cannot transfer information when in this mode
ADM Status (BN)	Green Solid	Power applied to module
	Yellow Solid	Active Communication
	Red Steady Flashing	Software upload from token in progress
	Red Random Flashing or Solid	Module error exists

Screen Components

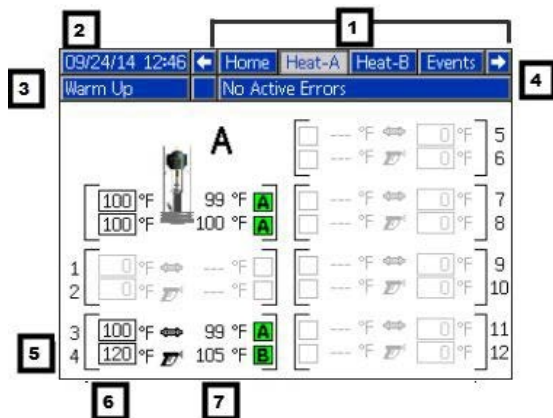

1. Screen Order
2. Current date and time
3. Operating Mode
4. Faults, Status
5. MZLP Plug Identifier
6. Zone Setpoint Temperature
7. Zone Actual Temperature

Operating Mode	Description	Component Status
System Off	The system does not have power.	<ul style="list-style-type: none"> • No system status indicator LED on the ADM • No heat • Pump is off
Inactive	The heating system and pumps are disabled.	<ul style="list-style-type: none"> • Yellow system indicator LED on the ADM • No heat • Pump is off
Warm Up	The system is heating the material to the setpoint temperature.	<ul style="list-style-type: none"> • Flashing green system status indicator LED on the ADM • Heat is increasing to setpoint temperature • Pump is off
Heat Soak	Heat zones are all at temperature. Material is soaking for a user specified amount of time.	<ul style="list-style-type: none"> • Flashing green system status indicator LED on the ADM • Heat is at setpoint • Material is absorbing more heat • Pump is off • Heat soak counter counts down on the Home screen.
Ready	All enabled zones are at setpoint temperature. The Air Motor does not have power.	<ul style="list-style-type: none"> • Flashing green system status indicator LED on the ADM • Heat is at setpoint • Pump is off
Active	The system is ready to dispense.	<ul style="list-style-type: none"> • Solid green system status indicator LED on the ADM • Heat is at setpoint temperature • Pump is on

Overview

A Heated Platen melts the sealant or adhesive and directs the molten material to the Pump inlet. The material then travels through a Heated Pump and heated fluid moves to the application tool.

Air and Fluid Hoses

The Therm-O-Flow requires Graco single-circuit material hoses rated at a maximum of 1250 watts. Make sure all air and fluid hoses are properly sized for the system.

Heat Control Zone

The Therm-O-Flow has 4, 8, or 12 heat zones. Zones for the Heated Platen and the Heated Pump are not included in the zone count. Zones 1 and 2, 3 and 4, 5 and 6, 7 and 8, 9 and 10, and 11 and 12 are each available through 12-pin connectors. The heated hoses have a 16-pin connector at the inlet, and an 8-pin connector at the outlet. All heated valves, manifolds, and heaters are equipped with an 8-pin mating connector.

MZLP-1

heat zones 3 and 4 on MZLP-1 must have devices connected to make the machine functional. An over-temperature jumper plug can be installed to allow the system to run without these devices installed.

NOTICE
For proper operation, cable must be plugged into zone 3-4 at all times.

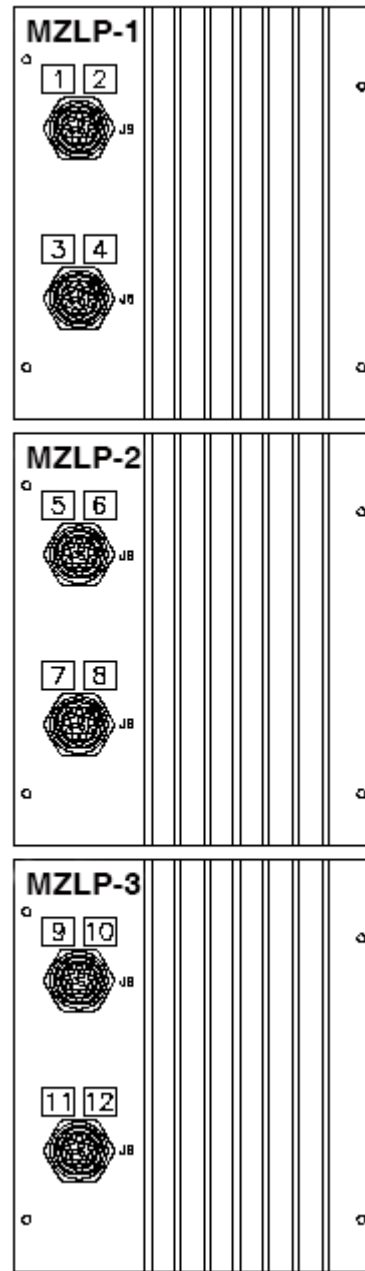

FIG. 6: Heat Control Zone Selection

Setup

1. Unpack the Ram
 2. Locate and Install the Ram
 3. Mechanical Setup
 4. Connect hoses to Electrical Control Panel
 5. Connect Electrical Control Panel to power source
 6. Ground system
 7. Select ADM settings
4. Make sure there is easy access to an appropriate electrical power source. The National Electrical Code requires 3 ft (0.9 m) of open space in front of the electrical panel. Comply with all local codes and regulations.
 5. When locating the system, do not install closer than 36 in. (914 mm) to vertical surfaces.

Unpack

1. Inspect the shipping box carefully for damage. Contact the carrier promptly if there is damage.
2. Open the box and inspect the contents carefully. There should not be any loose or damaged parts in the box.
3. Compare the packing slip against all items in the box. Repost any shortages or other inspection problems immediately.
4. Remove the unit from the skid and place it in the desired location. See **Location Requirements**.

Location Requirements

1. Make sure there is sufficient overhead clearance for the Pump and Ram when the Ram is in the fully raised position (approximately 75 in. (190.5 cm).)
2. If you are installing a vent hood, make sure there is sufficient horizontal clearance for it. Locate the Ram near a connection to the factory ventilation system.
3. Make sure the Integrated Air Controls for the Pump and Ram are fully accessible, with room to stand directly in front of the controls and the ADM.

Install System

Refer to **Dimensions**, page 110 for mounting and clearance dimensions.

Follow all **Location Requirements**, page 15, when selecting a location for the Ram.

1. Apply 50 psi download pressure to Ram.
2. Wrap the bar with the lifting sling.
3. Lift the system off the pallet using a crane or a forklift and place in desired location.
4. Level the base of the Ram, using metal shims.
5. Bolt the Ram to the floor, using anchors that are long enough to prevent the unit from tipping.

Mechanical Setup

1. Fill displacement Pump wet cup 2/3 full with Graco Throat Seal Liquid (TSL™) for Butyl and PSA materials.

NOTE: Use IsoGuard Select® (IGS) (part no. 24F516) for PUR or reactive Polyurethane material. IGS is designed to dissolve and suspend the Polyurethane materials. IGS will solidify after a period of time and should be replaced once the solidified lube does not return to liquid form after heating.

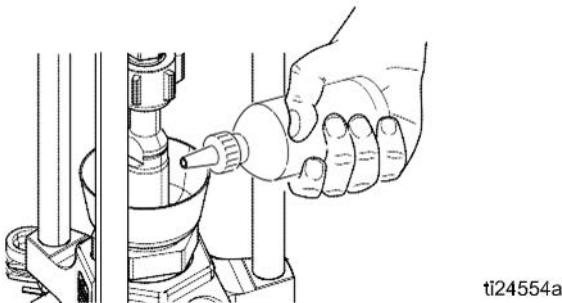

FIG. 7: Wetcup

2. Turn all air regulators to their full counterclockwise position. See **Integrated Air Controls**, page 9.
3. Connect a 1/2 in. (13 mm) air line from an air source to the system air inlet (H), capable of delivering a minimum of 25-50 cfm at 100 psi (0.7 MPa, 7.0 bar). **Do not use quick disconnects.**

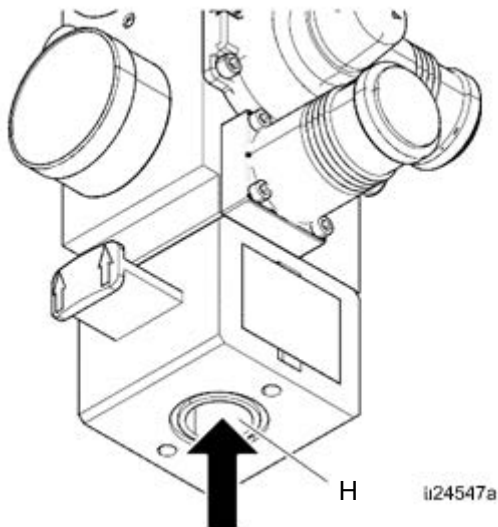

FIG. 8: Air Connection

4. Ensure Drum Low and Empty Sensors (C) are mounted as shown.

NOTE: The Drum Low and Empty Sensors are used to indicate that a drum is empty. The kit contains a sensor mounting bracket (A), activator (B), sensors (C1, C2), and a cable for connecting the panel inside the electrical enclosure.

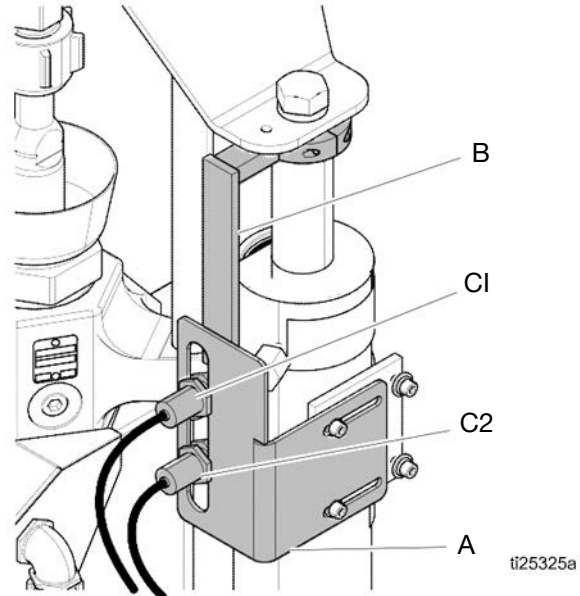

FIG. 9

5. Increase the distance between the low (C1) and empty (C2) sensors to increase the heat up time for the tandem secondary system. Lower the drum empty sensor (C2) to force the Heated Platen lower into the drum. If empty sensor is set too low, the Pump could cavitate and cause an alarm.

Install Heated Hose

To connect a hose to a fluid control device or heated manifold.

1. Install fitting and heated hose onto Pump outlet with the large electrical connector side toward the system. Use 2 wrenches to tighten hose. Torque to 45 ft-lbs (61 N•m).

NOTE: See **Accessories and Kits**, page 91, for available fittings and heated hoses.

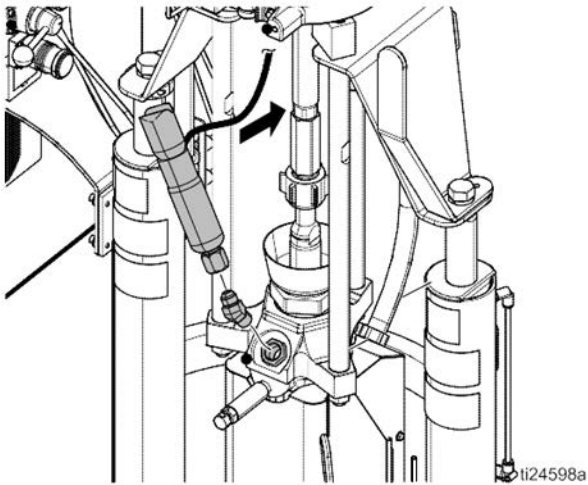

FIG. 10

2. Wrap exposed fittings on the Pump outlet with Nomex insulation and secure insulation using fiberglass tape.
3. Connect large heated hose connector to MZLP.

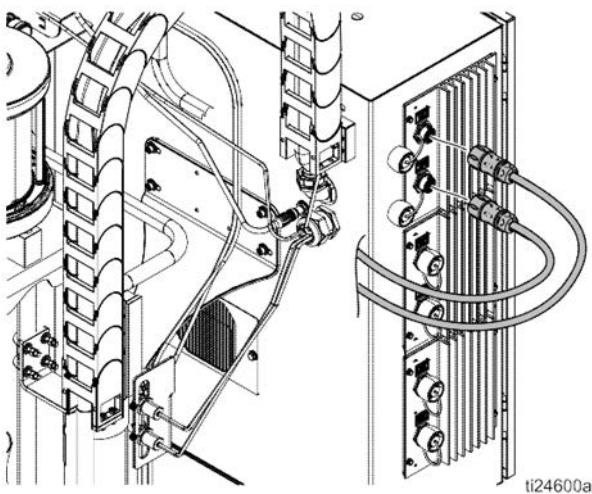

FIG. 11

4. Repeat for any remaining channels.
5. Install cap on any unused MZLP electrical connectors.
6. Connect the small 8 pin connector from the heated hose to the fluid control device or heated manifold.

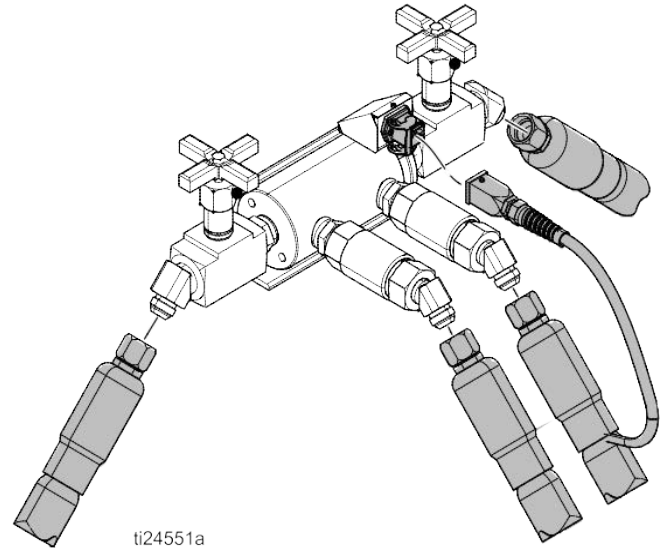

FIG. 12: Heated Manifold 243697

NOTE: The heated manifold (part no. 243697) shown. See **Accessories and Kits**, page 91, for available manifolds and fluid control devices.

7. Use 2 wrenches to tighten hose. Torque to 45 ft-lbs (61 N•m).
8. To connect multiple devices, see **Connect Multiple Devices**, page 18.

Connect Multiple Devices

If your application requires multiple fluid control devices:

- Connect heated hose electrical connections to the electrical enclosure. Remove from shipping box to connect heated hoses to the electrical enclosure. For additional cables, heated hose, and fluid control devices, see **Accessories and Kits**, page 91.

- Connect fluid control devices to a heated hose or the electrical enclosure. Use accessories if necessary.
- Setup all heat zones on Heat-A and Heat-B screens.

Example: Heated zones used to connect a primary and secondary system to a manifold and two guns. A-# zones are on the Heat-A screen and B-# zones are on the Heat-B screen.

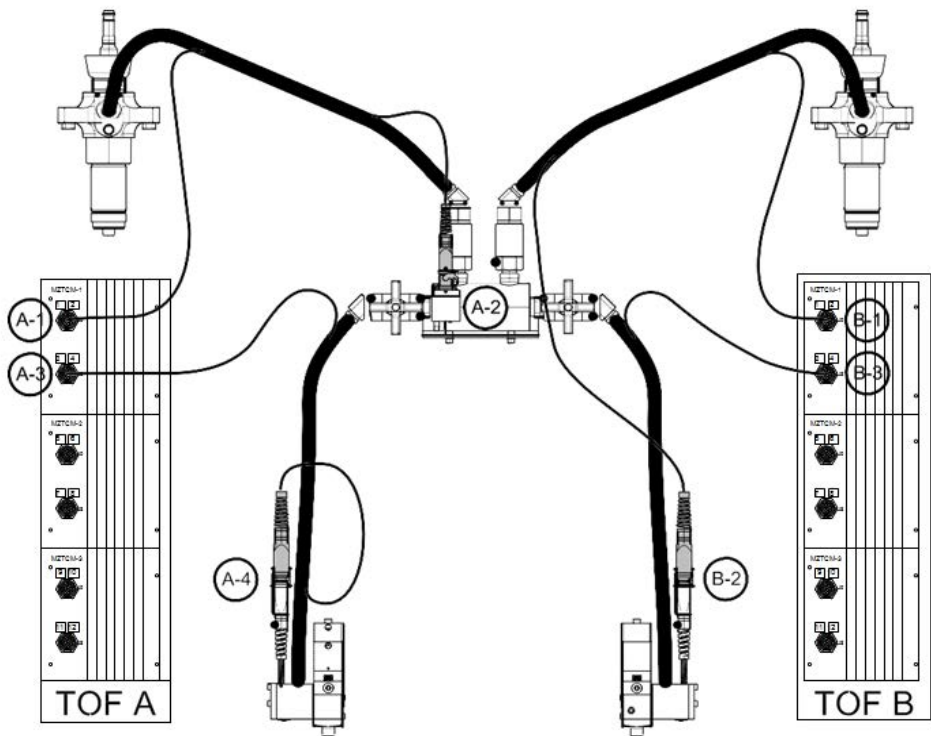
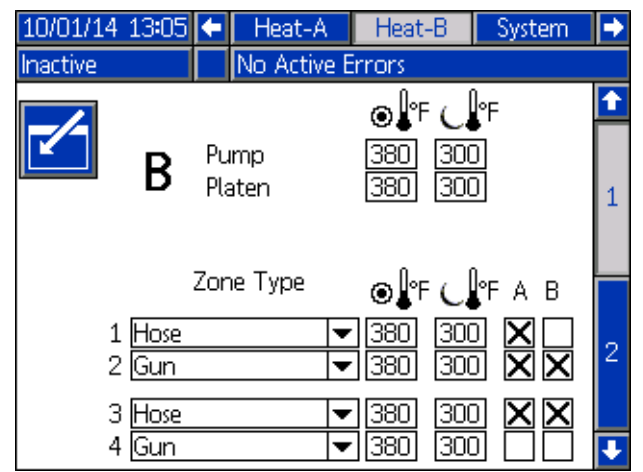
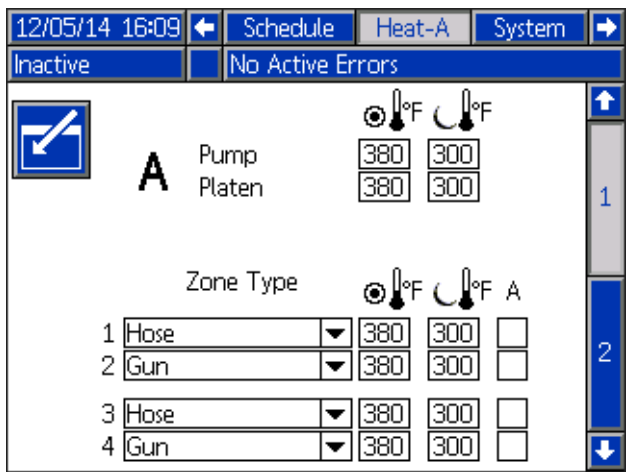

FIG. 13



u2/578a



NOTE: Pump settings will not be shown on Mini-5 systems with software version 1.01.042 or later.

Connect Power

The Electrical Control Panel comes already attached and wired to the Ram, however before the supply unit becomes functional you must connect the Electrical Control Panel to a power source.

				
All electrical wiring must be done by a qualified electrician and comply with all local codes and regulations.				

NOTE: Required voltage and amperage is noted on the Control Panel label. Before running power to the unit, make sure the plant electrical service meets the machine’s electrical requirements. Branch circuit protection shall be provided by the end user.

Use copper conductors rated 600 volts minimum and 167°F (75°C) minimum only. Torque to 55 in-lb (6.2 N•m).

Table 2 Electrical Requirements

Electric Panel Voltage	Hz	Phase	Platen	Full Load Amps	AWG
230 V	50/60	3	EF, ES	50	8 AWG
400 V/N	50/60	3	EF, ES	30	8 AWG
400 V	50/60	3	EF, ES	30	8 AWG
480 V	50/60	3	EF, ES	30	8 AWG
600 V	50/60	3	EF, ES	25	8 AWG

EF Standard Finned Bottom
 EM Mega-Flo
 ES Smooth Bottom

1. Locate the opening in the Control Panel’s top housing for the conduit that will enclose the wire from the facility’s power source. The hole will accept a cord diameter range of 0.7–1.2 in (17–30 mm).
2. Route the wire from the power source into the Control Panel housing, and then connect the power source wires to the appropriate terminals on the DISCONNECT switch.

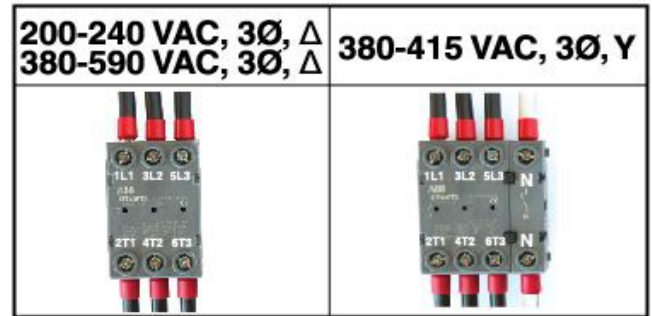



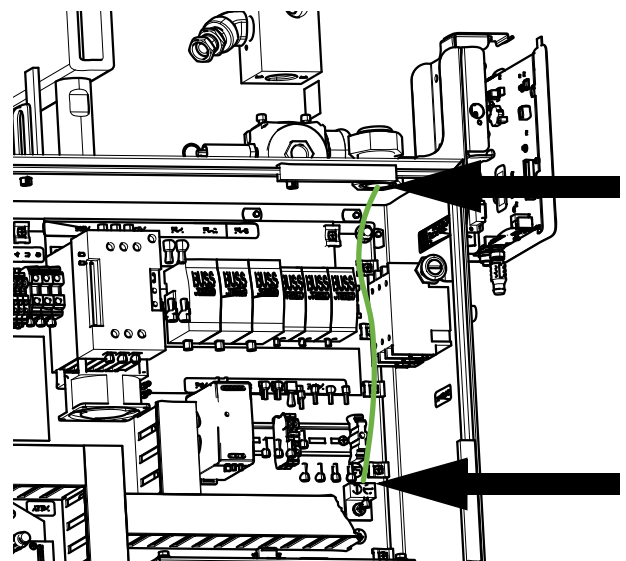

FIG. 14

				
To reduce the risk of fire, explosion, or electric shock, the resistance between the supply unit components and true earth ground must be less than 0.25 ohms.				

3. Connect the ground wire to the ground lug. Have a qualified electrician check the resistance between each Therm-O-Flow system ground and the true earth ground. The resistance must be less than 0.25 ohms. If the resistance is greater than 0.25 ohms, a different ground site may be required. Do not operate the system until the problem is corrected.

NOTE: Use a meter that is capable of measuring resistance at this level.



Grounding

Ground the unit as instructed here and in the component manuals.

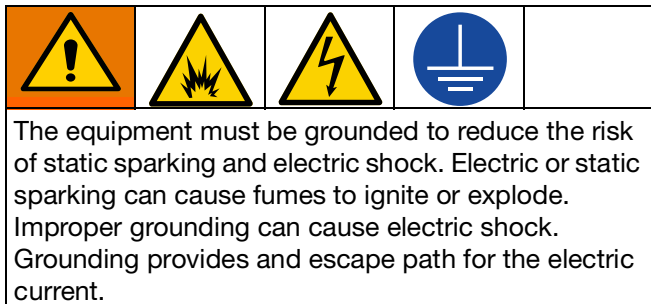

System: ground through ground lug in electrical enclosure. See **Connect Power**, page 19.

Air and Fluid Hoses: use only electrically conductive hoses.

Air compressor: follow manufacturer's recommendations.

Spray gun / Dispense valve: ground through connection to a properly grounded fluid hose and Pump.

Material drums: follow local code. Use only metal drums placed on a grounded surface. Do not place the drum on a nonconductive surface, such as paper or cardboard, which interrupts the grounding continuity.

To maintain grounding continuity when flushing or relieving pressure: follow instructions in your separate gun manual for instructions on how to safely ground your gun while flushing.

Connect Secondary System

A secondary system is a Therm-O-Flow supply system that connects to the primary Therm-O-Flow system, with the ADM. See **Models**, page 7 for secondary system model numbers.

1. Connect adapter cable (AC) and communication cable (SC) to the secondary electrical enclosure and rout to splitter (SS) installed on the primary system.
2. To enable a secondary system, select "Enable Tandem System" on the System 1 screen. See **Select ADM Settings**, page 23.

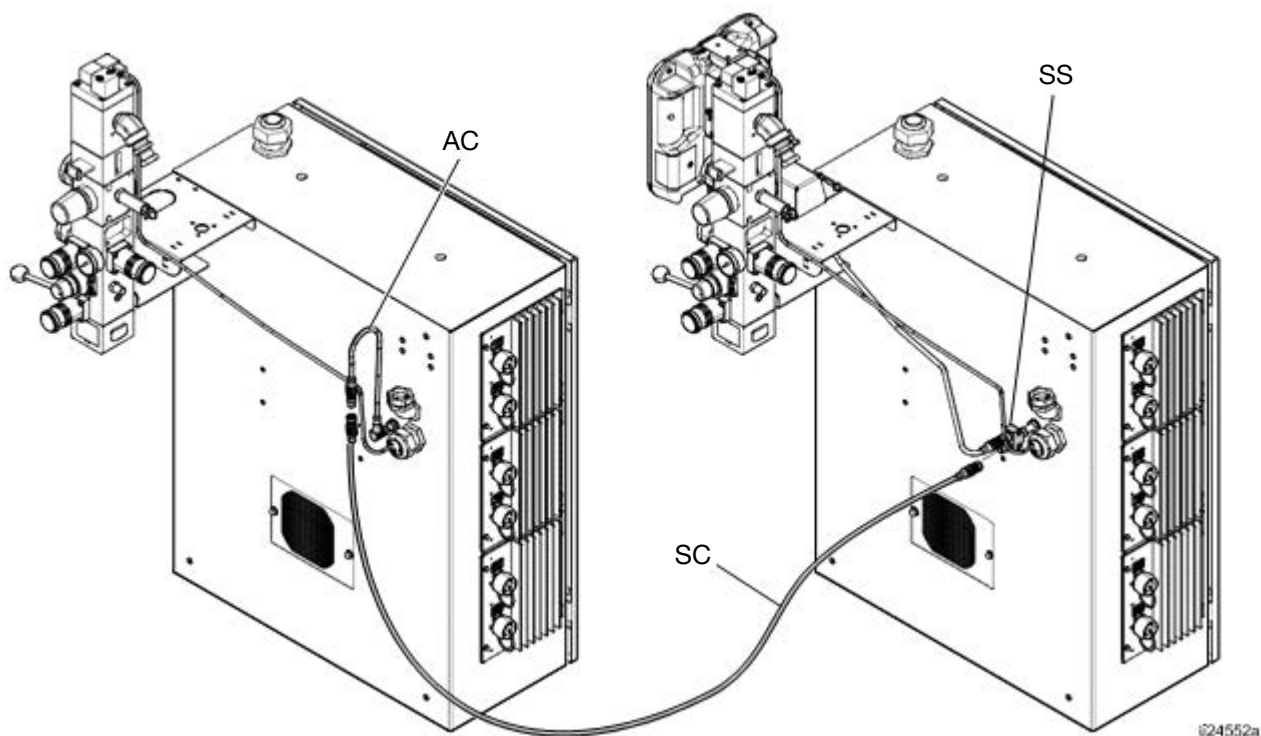



FIG. 15

Check Sensor Resistance

				
To reduce risk of injury or damage to equipment, conduct these electrical checks with the Main Power Switch OFF.				

The package includes up to twelve heat sensors and controllers for each of the heated zones. To check sensor resistance:

1. Turn Main Power Switch OFF.



2. Wait for components to cool down to ambient room temperature 63°-77°F (17°-25°C). Check electrical resistance for the components.

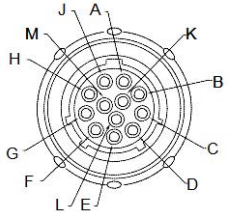

MZLP	Pins	TOF Hose
First Heat Zone	A, J	
Second Heat Zone	C, D	
First RTD	G, K	
Second RTD	M, K	
Earth Ground	B	

3. Replace any parts whose resistance readings do not comply with the ranges listed in the RTD Sensors chart below.

Table 3 RTD Sensors

MZLP	MZLP Plug	Component	RTD Range (Ohms)
		Ram Plate	100 +/- 2
		Fluid Pump	100 +/- 2
1	1, 2	Heated Accessory 1	100 +/- 2
		Heated Accessory 2	100 +/- 2
	3, 4	Heated Accessory 3	100 +/- 2
		Heated Accessory 4	100 +/- 2
2	5, 6	Heated Accessory 5	100 +/- 2
		Heated Accessory 6	100 +/- 2
	7, 8	Heated Accessory 7	100 +/- 2
		Heated Accessory 8	100 +/- 2
3	9, 10	Heated Accessory 9	100 +/- 2
		Heated Accessory 10	100 +/- 2
	11, 12	Heated Accessory 11	100 +/- 2
		Heated Accessory 12	100 +/- 2

Check Heater Resistance

				
To reduce risk of injury or damage to equipment, conduct these electrical checks with the Main Power Switch OFF.				

2. Make electrical resistance checks for the components.
3. Replace any parts whose resistance readings do not comply with the ranges listed in tables.

NOTE: Check resistance at ambient room temperature 63°-77°F (17°-25°C).

1. Turn Main Power Switch OFF.



Table 4 Heaters

Component	Resistance Across Terminals	Unit Input Voltage	Platen or Pump Module	Resistance Values
Platen*	SSR-1 -5 to SSR-1-6, 107 to 108	220 - 240V	All configurations	12.4 to 15.9 Ohms
	SSR-1-5 to SSR-1-6, 107 to 108	380 - 600V	All configurations	49.6 to 63.6 Ohms
	SSR-1-5/107 to Terminal 5/6, Terminal 5/6 to SSR-1-6/108			24.8 to 31.8 Ohms
	Any Terminal to Case	All voltage versions	All	Greater than 70,000 Ohms
Pump	2610 to 2620, T1/B1 to T3/B3	All voltage versions	All	43.2 to 53 Ohms

* There are two heater elements wired either in series or parallel. Each element has a resistance of 24.8 to 31.8 Ohms.

Select ADM Settings

NOTE: See **Appendix A - ADM**, page 98 for detailed ADM information, including general operation.

1. Turn Main Power Switch ON.



2. When the ADM is finished starting up, press  to switch from the Operation screens to the Setup screens. Use the arrows to navigate between screens.
3. Check system settings on the System 1 screen.

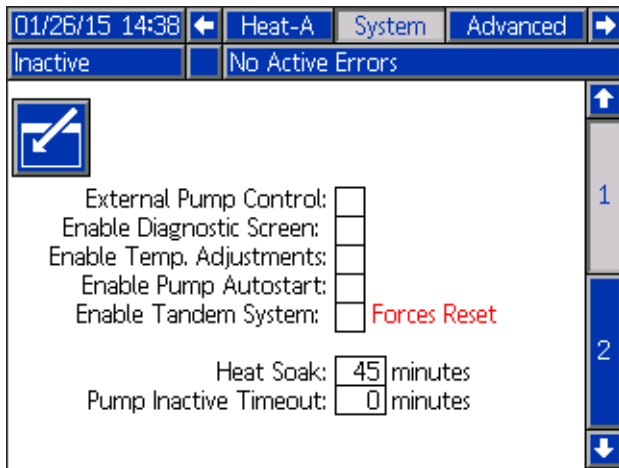

NOTE: Pump inactive timeout will not be shown on Mini-5 systems with software version 1.04.042 or later.

4. Set alarm levels on the System 2 screen.

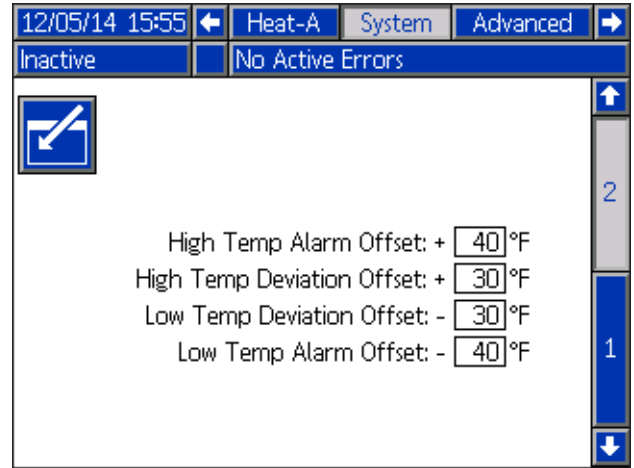

5. Set primary system setpoint and setback temperatures for the Pump, Platen, and heat zones on the Heat-A-screens.

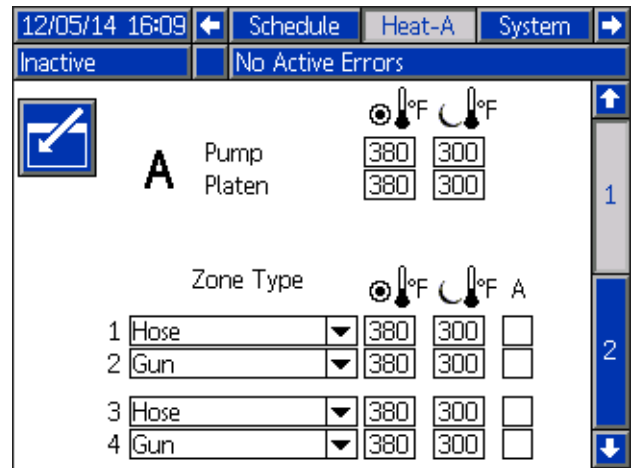

NOTE: Setback temperatures must be at least 20°F (10°C) lower than the setpoint temperatures.

NOTE: Pump setpoint and setback temperature will not be shown on Mini-5 systems with software version 1.04.042 or later.

NOTE: To ensure accurate hose temperatures, be sure all heated hoses have their “zone type” set to “Hose.” Hoses are only present on odd zone numbers: 1, 3, 5, 7, 9, or 11.

- a. Select the appropriate “Zone Type” for all installed zones.
- b. Check the “A” and “B” boxes according to which systems needs to use the heated accessory.

6. If a secondary system is used, set temperatures on the Heat-B-screens.
7. Set the system date and time on the Advanced 1 screen.

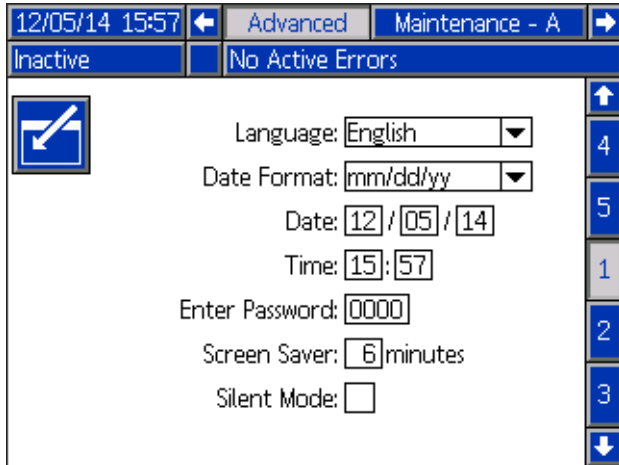

9. To setup the optional Schedule function, see **Schedule**, page 36. The schedule function allows the system to automatically enable and disable heating and setback at specified times.
10. Optional: Set any remaining settings in the Setup screens before using the system. These are not required for system operation, but include useful functions. See **Appendix A - ADM**, page 98 for detailed information about each setup item.

8. Set the temperature and mass units on the Advanced 2 screen. Set the specific gravity of the material for Material Tracking functionality.

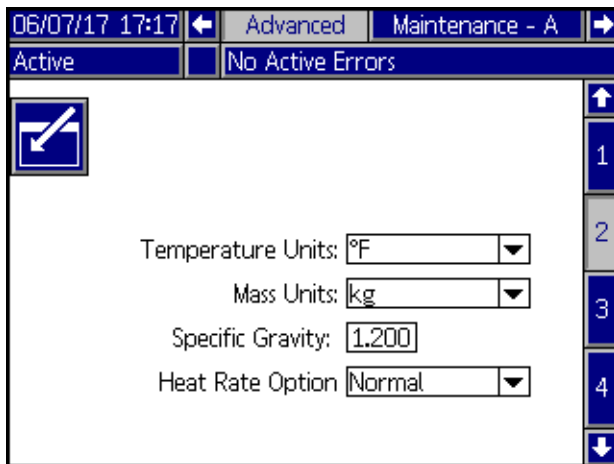

NOTE: If the Specific Gravity is set to zero, the Home screen will display a cycle counter instead of grams or pounds.

Connect PLC (Hard Wired Interface Version)



A PLC can control and monitor all items shown in the Customer Digital Inputs and Outputs shown on the Diagnostics screen. See **Appendix A - ADM**, page 98.

When the PLC has control of the system:

- Functionality is restricted from the ADM
- Automatic crossover is disabled. Rely on the PLC and machine state indicators to know when to cross over using the I/O.

Table 5 Customer Input

Signal No.	Unit A	Description
1	Heat On Request	Turn on the Heat
2	Setback Request	Put the Unit in Setback
3	Pump On Request	Turn on the Pump
4	PLC Control Request (input applies to primary unit A only)	Control the primary and secondary TOF systems from the PLC instead of the ADM

Table 6 Customer Output

Signal No.	Unit A or B	Description
1	Run State Bit Low	See Run State Chart
2	Run State Bit High	See Run State Chart
3	Error State Bit Low	See Error State Chart
4	Error State Bit High	See Error State Chart

Table 7 Output Error States

Error State Bit High	Error State Bit Low	
0	0	Machine is good, no errors are present
0	1	Active Unit Drum Low
1	0	Active Unit Drum Empty
1	1	Alarm Present in System

Table 8 Output Run States

Run State Bit High	Run State Bit Low	
0	0	Pump Off/ Heat Off
0	1	Pump Off/ Heat On
1	0	Pump Off/ Heat At Temp
1	1	Pump On/ Heat At Temp

NOTE: All outputs are normally open when power is OFF. For error (alarm) output, the contacts close when an alarm occurs. For all others, contacts close.

NOTE: The TOF system ships with two screw terminal connectors that plug into MZLP connectors H1 and H2. Connectors are located in a bag on the inside of the electrical enclosure. To replace the connectors, order kit 24P176.

1. Turn Main Power Switch OFF.
2. Open the electrical enclosure door.
3. Route I/O cables through strain relief.
4. Remove power from the PLC.
5. Connect the PLC to connectors H1 and H2.

NOTE: Each connector has four signals. The MZLP board specifies the input range for each signal. See the following table for pin assignments.

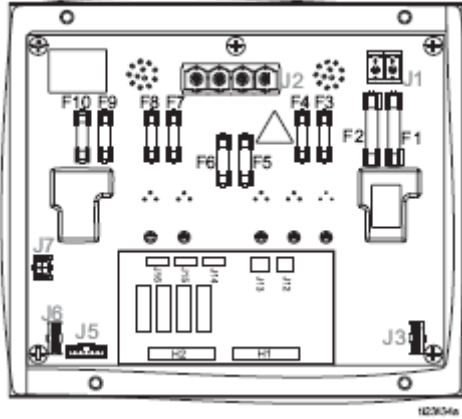

FIG. 16

H1 Customer Input	
Signal	Pin
1	1,2
2	3,4
3	5,6
4	7,8

H2 Customer Output	
Signal	Pin
1	1,2
2	3,4
3	5,6
4	7,8

Inputs: High: 10–30 VDC, Low: 0–5 VDC. Inputs function without concern for polarity. Applying “high” voltage will turn the heaters on and enable setback. Removing voltage will turn the heaters off and disable setback.

Outputs: 0–250 VAC, 0–30 VDC, 2A Maximum.

PLC Connections Block Diagrams

The following block diagrams show how to connect customer inputs and outputs to the MZLP. For convenience, each system ships with connector kit 24P176. If a connector is lost or damaged, order kit 24P176 for replacements.

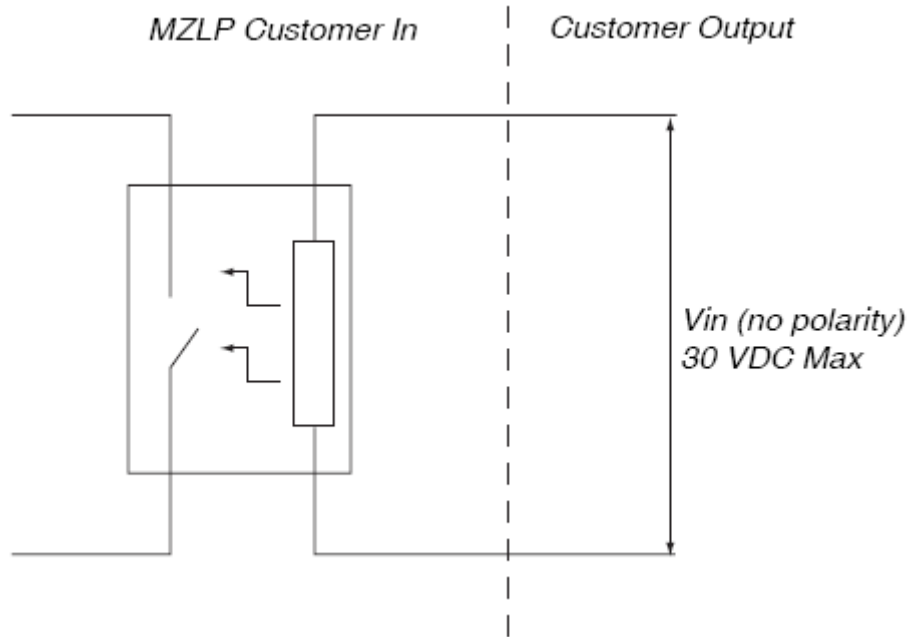

FIG. 17: Customer Input

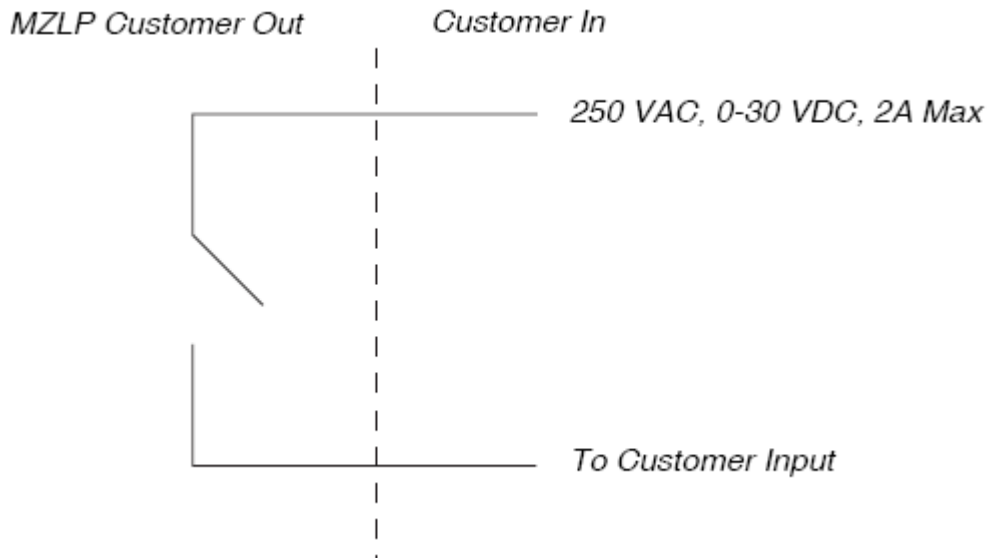

FIG. 18: Customer Output

Operation

NOTICE

For proper operation, cable must be plugged into zone 3-4 at all times.

1. Turn the Main Power Switch ON. The Graco logo will display until communication and initialization is complete.



2. Press the  button. Verify the machine is in “Warm Up” state, and that the temperatures are increasing. Allow the system to reach the “Ready” state before pumping. The Pump will automatically turn on, if autostart is enabled in setup screens, when all the heat zones reach their setpoint temperature.

Purge System



NOTICE

Purge the system before initial use and when chemicals are changed to prevent material contamination, which may cause the material to fail or perform poorly. The system was factory- tested using a light soluble oil, a soybean oil, or some other oil as tagged. Flush the system to avoid contaminating the material that has been designated for initial material loading.

NOTICE

Use fluids that are chemically compatible with the equipment wetted parts. See **Technical Specifications** in all of the equipment manuals.

1. Select the material for the initial material load.
2. Verify whether the factory-test oil and the initial material load are compatible:
 - a. If the two substances are compatible omit the remaining steps in this procedure and refer to **Load Material**, page 29.
 - b. If the two substances are incompatible perform the remaining steps in this procedure to flush the system.
3. Select a pail of material that can eliminate the factory-test oil from the system. If necessary, check with Graco or the material supplier for a recommended solvent.
4. Before purging, be sure the entire system and waste pail are properly grounded. See **Grounding**, page 20.
5. Turn all heat zones’ setpoint temperature to the material manufacturer’s recommended dispense temperature, or a minimum of 100°F (37°C) minimum.

NOTE: Remove any dispense valve orifices before purging. Reinstall after purging has been completed.

6. Purge the material through the system for approximately 1 to 2 minutes.
7. Remove the pail if purge material was used. See **Change Pail**, page 37.

Load Material

NOTICE

To prevent damage to Platen wipers, do not use a pail of material that has been dented or damaged. An empty pail clamp can interfere with up and down operation of the Ram. When raising the Ram, make sure the pail clamp stays clear of the Platen.

NOTE: Before loading material, make sure there is a minimum overhead clearance of 75 in. (191 cm) and all air regulators are backed off to their full counterclockwise position.

1. Open the Main Air Slider Valve (CA).

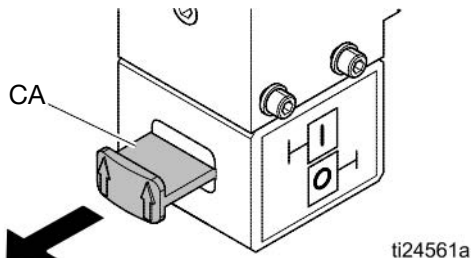

2. Set Ram Director Valve (CC) to UP and slowly turn the Ram Up Regulator (CD) clockwise until the Platen (G) begins to rise.

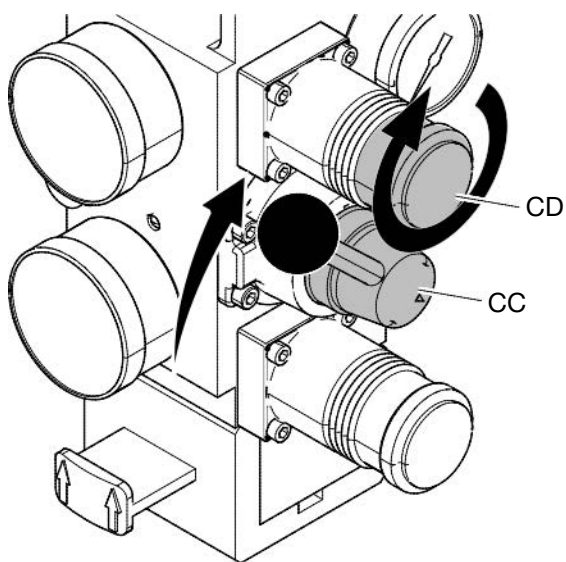

FIG. 19: Raise the Platen

3. Apply a thin coating of high temperature grease lubricant (part no. 115982) to the Platen pail seals.

4. Fill displacement Pump wet cup 2/3 full with Graco Throat Seal Liquid (TSL™) for Butyl and PSA materials.

NOTE: Use IsoGuard Select® (IGS) (part no. 24F516) for PUR or reactive Polyurethane material. IGS is designed to dissolve and suspend the Polyurethane materials. IGS will solidify after a period of time and should be replaced once the solidified lube does not return to liquid form after heating.

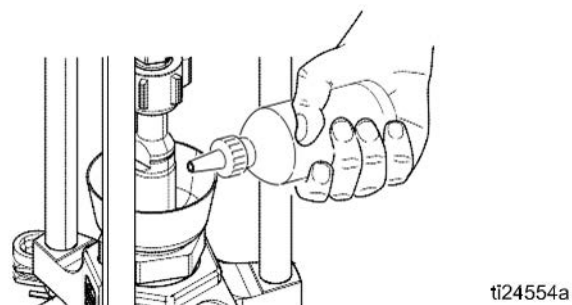

FIG. 20: Wetcup

5. Open pail, remove any packing material, and inspect material for any contamination.
6. Slide the pail against the stops at the back of the Ram baseplate.

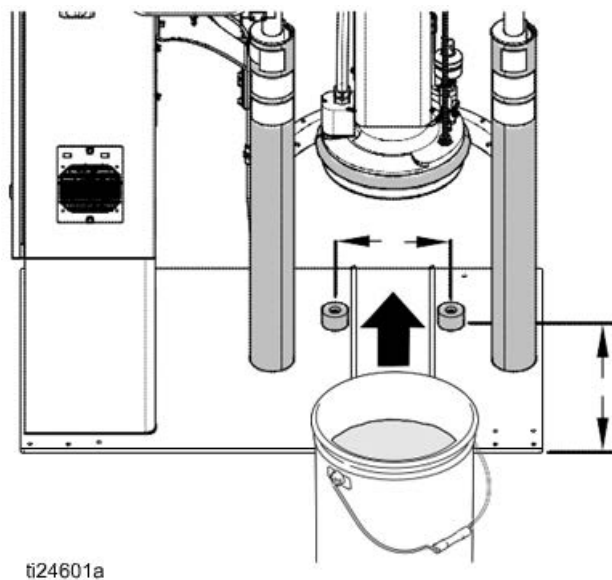

FIG. 21: Drum Placement

- Remove the Ram Plate Bleed Stick (R).

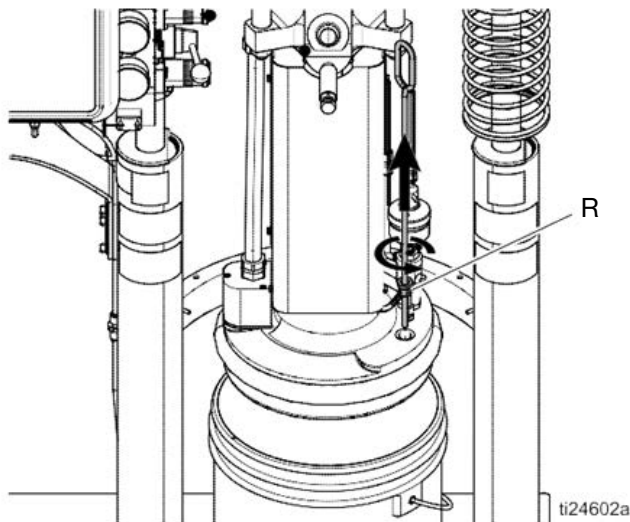

FIG. 22: Platen Bleed Handle

- Set Ram Director Valve (CC) to down and lower the Platen.

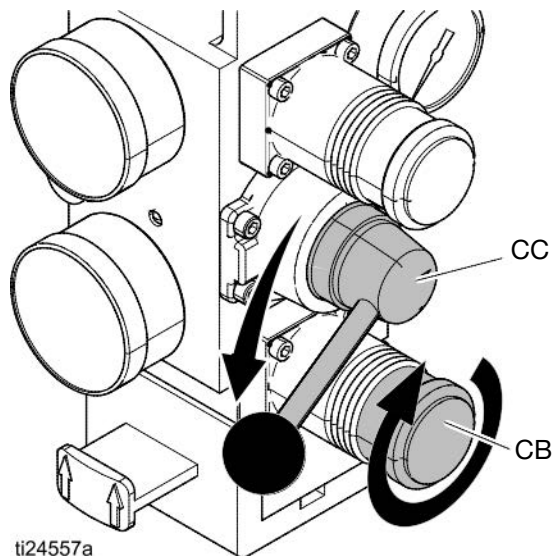

FIG. 23: Lower the Platen

- Slowly turn the Ram Down Air Regulator (CB) clockwise to approximately 5–10 psi (34–69 kPa, 0.3–0.7 bar). The Platen will begin to lower into the pail.
- After the Platen seals enter the material pail, adjust the Ram Down Air Regulator (CB) to 30–50 psi (207–345 kPa, 2.1–3.4 bar).
- When the Ram stops, reinsert the Ram Plate Bleed Stick (R) and hand tighten.

Heat Up System

<p>To reduce the risk of bursting a hose, never pressurize a hot melt system before turning on the heat. The air will be locked from the Air Motor until all temperature zones are within a preset window of the temperature setpoints.</p> <p>Keep the dispense valve open over a waste container while the system is heating up and also when cooling down. This will prevent a pressure build-up caused by fluids or gases expanding from the heat.</p>				

NOTE: Operate at the lowest temperature and pressure necessary for your application.

- Turn the Main Power Switch on the Electrical Control Panel door to the ON position.



- Press the button. The zones begin to heat (provided they are enabled). Press if the zones do not begin to heat. Display status bar reads **Warm Up**. When temperature reaches setpoint, the display status bar reads **Heat Soak**. When heat is on, the status will display in the status bar. See **Advanced Display Module (ADM)**, page 11, for operation mode descriptions.

NOTE: The air will be locked from the Air Motor until all temperature zones are within a preset window of the temperature setpoints, allowing the system to heat fully and complete the material heat soak period.

Prime Pump



1. Ensure that the system has completed the heat soak cycle. The display status bar should read **Active**.
2. Adjust the Air Motor Air Regulator (CK) to 0 psi.

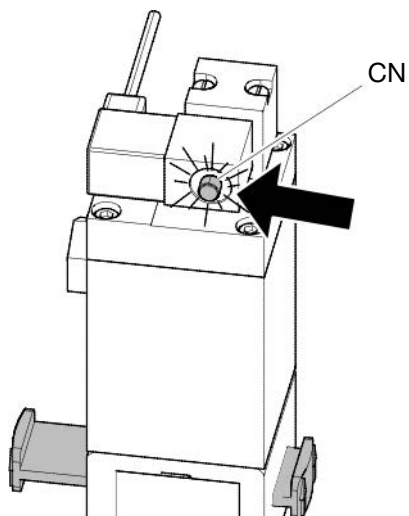
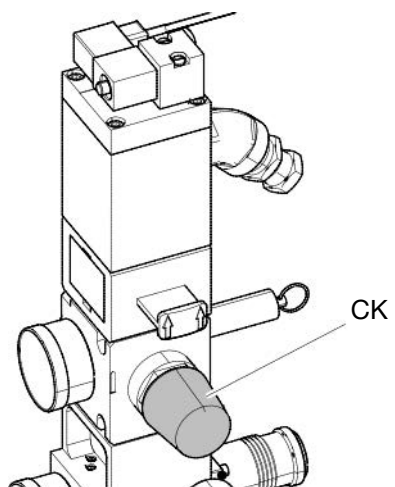

3. Adjust the Air Motor Slider Valve (CM) to the open position.

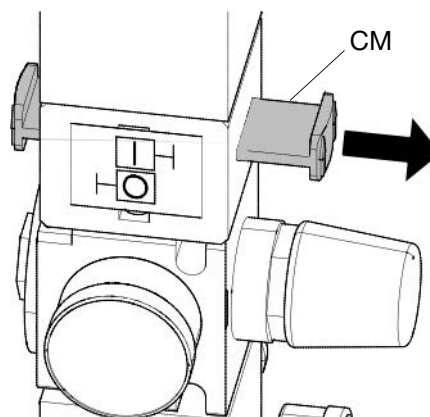

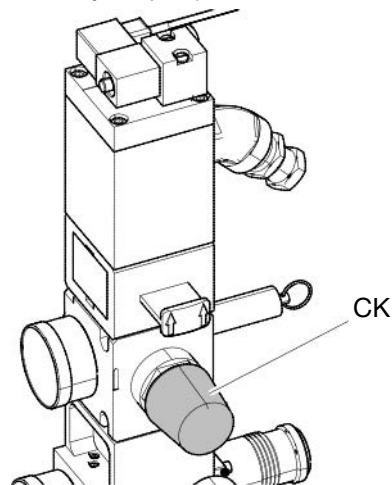

4. Adjust the Air Motor Air Regulator (CK) to approximately 20 psi (138 kPa, 1.38 bar).

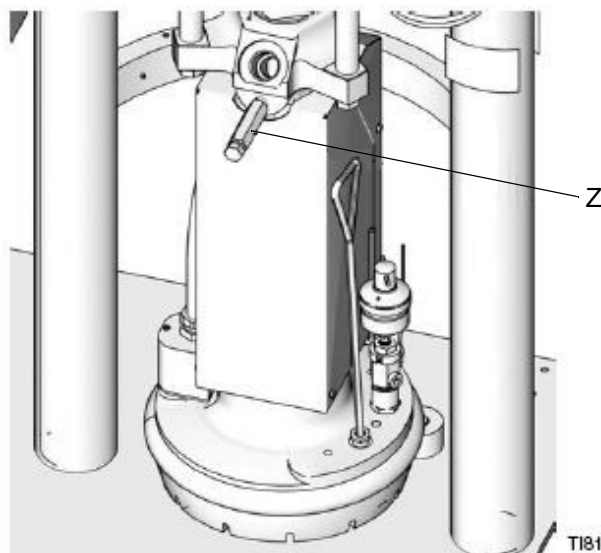

5. Place a waste container under the bleed stem (Z). Using an adjustable wrench, open the bleed stem counterclockwise 1/3 -1/2 turn.



TI8143A

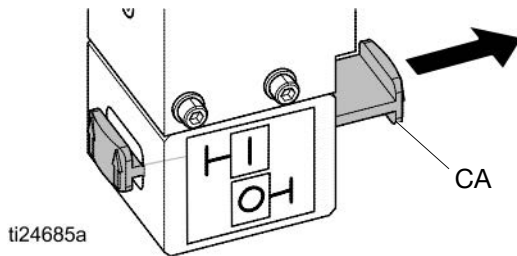

6. If a new pail was installed and the unit is equipped with proximity sensors, press the Pump Ready button . Press the pause button  on material tracking.
7. Adjust the Air Motor Air Regulator (CK) up by 5 psi (34 kPa, 0.3 bar). Never adjust the regulator by more than 5 psi (34 kPa, 0.3 bar) increments. Make sure the Pump begins to cycle and heated material flows from the bleed stem (Z) after several cycles of the Pump.
8. Prime the Pump until it moves smoothly in both directions with no air popping or erratic movement and close the Main Air Slider Valve (CA).



9. Press the Play button  on the home screen to enable material tracking and press the Pump ready button.

For Tandem Operation

Complete steps 1-5 on page 31 for the inactive unit. Note that the heat will remain on for the inactive unit until the system is turned off.

6. If a new drum has been installed in the inactive unit, press the Pump Ready button  on the inactive unit. The light on the solenoid of the inactive unit should be on (CN).
7. Adjust the Air Motor Air Regulator (CK) up by 5 psi (34 kPa, 0.3 bar). Never adjust the regulator by more than 5 psi (34 kPa, 0.3 bar) increments. Make sure the Pump begins to cycle and heated material flows from the bleed stem (Z) after several cycles of the Pump.
8. Prime the Pump until it moves smoothly in both directions with no air popping or erratic movement and close the bleed stem (Z).
9. Press the Pump Ready button  for the inactive unit.

Prime System



1. Close the Main Air Slider Valve (CA).

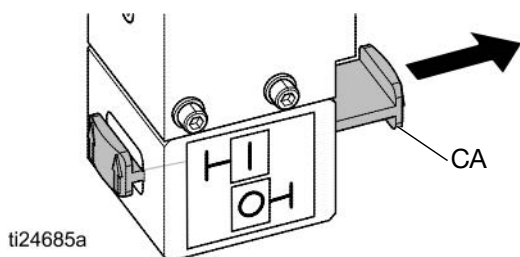

2. If using a manual gun, lock the dispense valve trigger open by pulling and securing the trigger using the trigger retainer (Z).

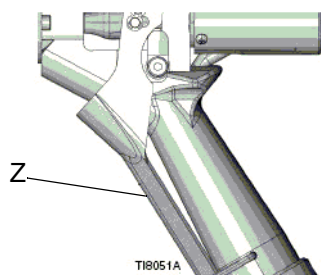

3. Place the dispense valve over a waste container.
4. Press the pause material tracking button  on home screen.
5. Slowly open the Main Air Slider Valve (CA).
6. Prime the system until a smooth flow of material dispenses from each dispense valve.

NOTE: On initial system startup, the Pump will cycle until the hoses are filled. If a new drum was placed on the frame, the Pump will cycle until all air has been removed.

7. Close the Main Air Slider Valve (CA) and release the trigger lock.
8. Engage the trigger lock.

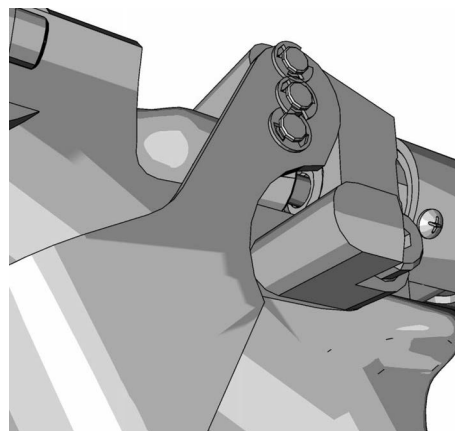



FIG. 24: Trigger Lock Engaged

9. Press  to engage material tracking.
10. Turn the Air Motor Regulator to operating pressure.

NOTE: The system is now ready to operate.

Setback Mode

Set the ADM to setback mode if the system will only be inactive for a few hours. This will reduce the time the system needs to return to setpoint temperatures.

1. Press  to enter Setback Mode.

NOTE: The amount of time before the Pump is automatically placed in setback is determined by the Pump Inactivity Timeout, located on System Setup Screen 1. See **Setup Screens**, page 102.

Pressure Relief Procedure



Follow the **Pressure Relief Procedure** Whenever you see this symbol.

This equipment stays pressurized until pressure is manually relieved. To help prevent serious injury from pressurized fluid, such as skin injection, splashing fluid and moving parts, follow the **Pressure Relief Procedure** when you stop spraying and before cleaning, checking, or servicing equipment.

NOTE: If using a different dispense applicator, see the applicator manual for pressure relief instructions.

1. Engage the trigger lock.

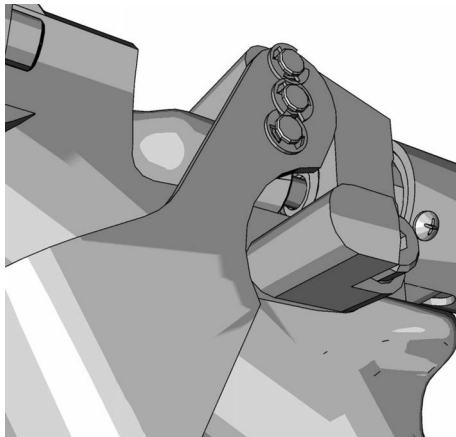
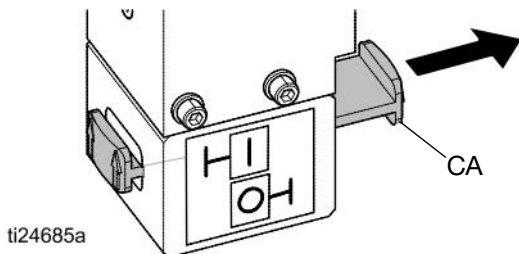
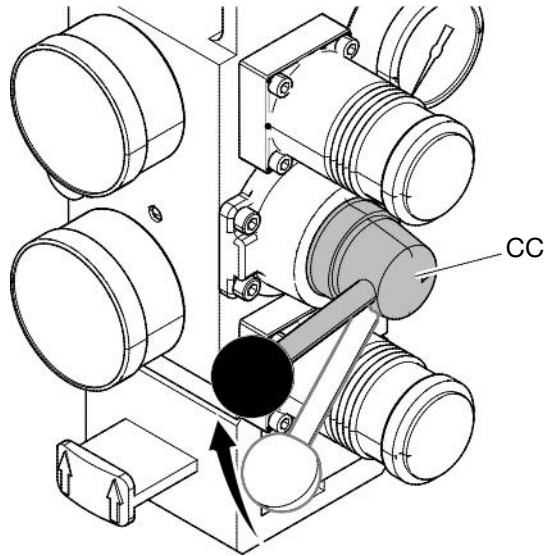

Fig. 25: Engaged

2. Close the system Main Air Slider Valve (CA).



3. Set the Ram Director Valve (CC) to the neutral position.



4. Disengage the trigger lock.

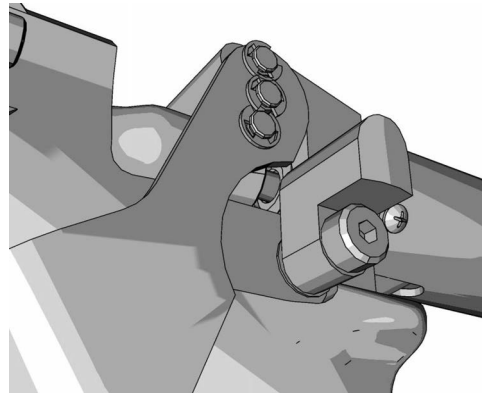
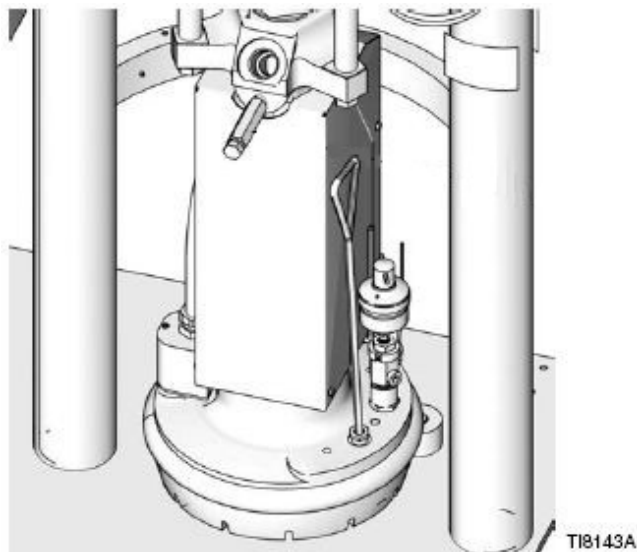

Fig. 26: Disengaged

5. Hold a metal part of the gun firmly to a grounded metal pail. Trigger the gun to relieve pressure.
6. Engage the trigger lock.
7. Open all fluid drain valves in the system, having a waste container ready to catch drainage. Leave drain valve(s) open until you are ready to dispense again.
8. If you suspect the tip or hose is clogged or that pressure has not been fully relieved after following the steps above, **VERY SLOWLY** loosen hose end coupling to relieve pressure gradually, then loosen completely. Clear hose or tip obstruction.

NOTE: If work needs to be performed on the Ram portion, perform the following additional steps to relieve any trapped air in the inactive portion of the Ram.

9. Validate that the Heated Pump is fully supported and is resting on the bottom plate.



10. Toggle the Ram Director Valve up and down to relieve any trapped air.

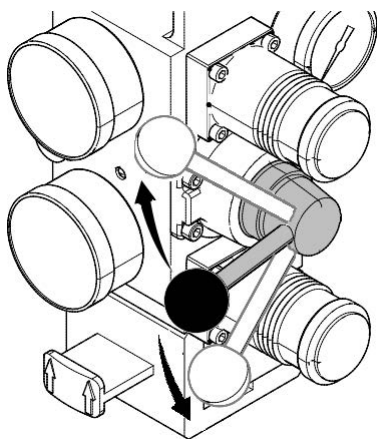

Stop Controls

Normal Stop Control

To stop all electrical and most pneumatic processes, press the System Shutdown button  located on the ADM.

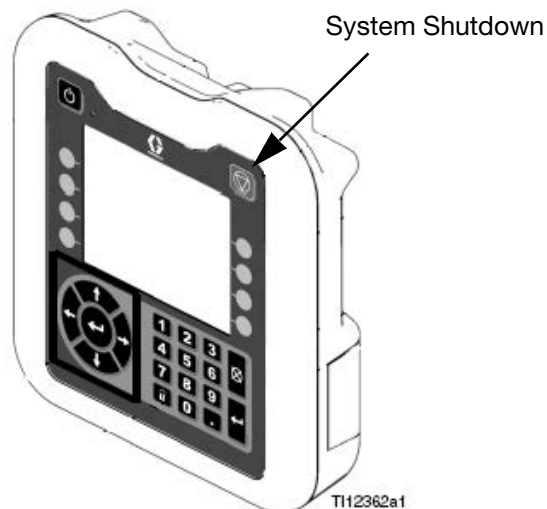

All electrical operations will be shut down and the air pressure to the Air Motor will be immediately relieved, which will stop the movement of the Heated Pump.

Electrical components located in the main control box will remain energized, but all operations will stop until

the system Enable/Disable button  has been pressed.

The Ram Director Valve will remain operable.

Air Motor and Heated Pump Stop

To stop only the Air Motor and Heated Pump, close the Air Motor Slider Valve (CM). This is the preferred method while changing drums.

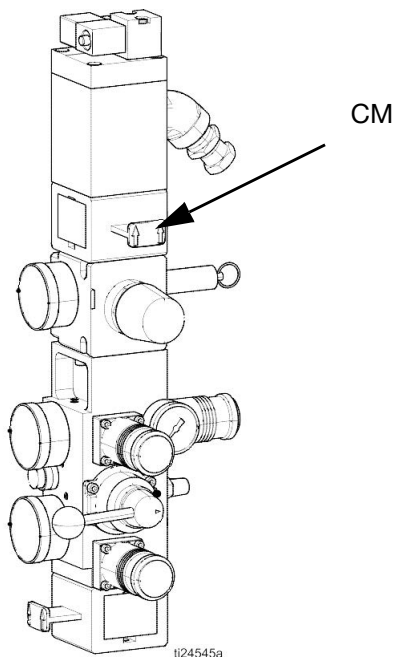

Air pressure to the Air Motor will be immediately relieved, which will stop movement of the Heated Pump but allow the heater to remain operable.

The Ram Director Valve will also remain operable.

The Air Motor Slider Valve can be locked in the closed position.

Total System Shutdown

To stop all electrical and most pneumatic processes, turn the Main Power Switch off.





This will remove all electrical power to the system past the Main Power Switch.

Air pressure to the Air Motor will be relieved, which will stop movement of the Heated Pump.

The Ram Director Valve will remain operable.

The Main Power Switch can be locked in the open position.

Shutdown

1. Press  to disable the heaters and Pump. The screen will say "Inactive". If using the Schedule function, the heaters and Pump will be disabled automatically at the set time. Only press  to disable the heating system before the set time. If the heaters were manually disabled, the Schedule function will automatically enable them at the next set time.

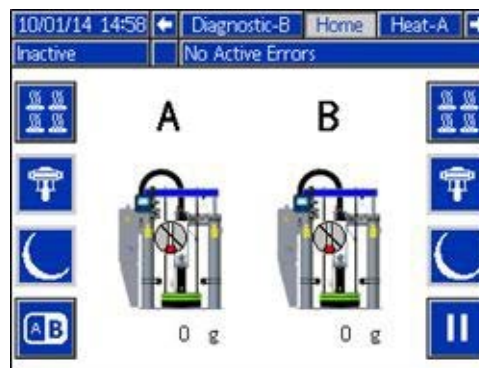

NOTE: Do not perform step 2 if using the Schedule function. Leave the power on.

2. Turn the Main Power Switch OFF.



Schedule

The Schedule function allows the user to specify times when the system will automatically turn ON and OFF the heaters and Pump.

A screenshot of the instrument's control interface showing the 'Schedule' function. The top bar shows the date and time '11/27/13 10:01' and navigation buttons for 'Maintenance', 'Schedule', and 'System'. The main display area shows a weekly schedule grid with columns for 'Mon', 'Tue', 'Wed', 'Thu', 'Fri', 'Sat', and 'Sun'. The grid contains time slots for ON and OFF events, with some cells highlighted in red and others in green.

	Mon	Tue	Wed	Thu	Fri	Sat	Sun
ON	06:45	06:45	06:45	06:45	06:45		
OFF	11:50	11:50	11:50	11:50	11:50		
ON	12:20	12:20	12:20	12:20	12:20		
OFF	18:30	18:30	18:30	18:30	18:30		

Table 9 Schedule Screen Color Identification

Color	Description
Green	System on
Yellow	Setback
Red	System off
Gray	Disabled

Set Schedule Times

Times are set using a 24-hour clock. Several on and off times can be set each day.

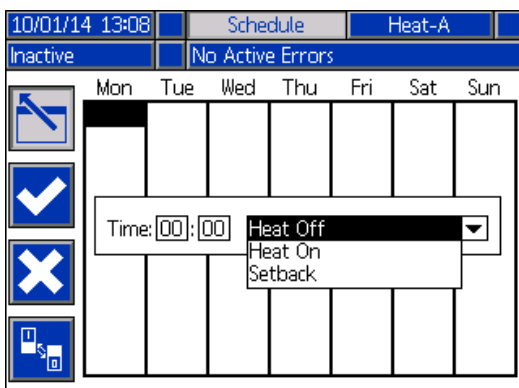

1. On the Schedule screen (in the Setup screens), set the ON times for each day of the week
2. Set the OFF times for each day of the week.
3. Set the setback times for each day of the week.

Enable Schedule Function

The Schedule function is automatically enabled when values are entered in the Schedule screen. To disable a scheduled event, navigate to the event and press .

The event will appear gray on the screen when it is disabled. To re-enable an event, navigate to the event and press .

The event will appear red (system off), yellow (system setback), or green (system on). If no events are needed, turn the Main Power Switch OFF to prevent system from automatically enabling and disabling the heaters.

Use the Schedule Function

At the end of the work day leave the Main Power Switch ON. The Schedule function will automatically enable and disable the heaters and Pump at the specified times.

Change Pail



To prevent serious burns from dripping material, never reach under the Heated Platen after the Platen is out of the pail.

Follow the procedure to change the pail on a fully heated system.

NOTICE

Be sure to reload the empty supply unit with a full pail of material immediately. Do not raise the Ram and remove the Platen from the empty pail until you are ready to immediately install a new pail.

Do not raise the Ram and remove the Platen from the empty pail unless the supply unit is at full operating temperature. Drum changes can only be performed when the system is heated.

An empty pail clamp can interfere with the up and down operation of the Ram. When raising or lowering the Ram, make sure the pail clamp stays clear of the Platen assembly.

Do not use a pail of material that has been dented or otherwise damaged; damage to the Platen wipers can result.

All systems include Low/Empty Sensors:

- The air will shut off to prevent the Pump from cavitation. If the Light Tower kit is installed, a solid red light indicates that the pail is empty and ready to change.
- In a tandem system, a flashing red light means that both drums are empty and the system has shutdown.

1. Press  to stop material tracking.

Operation

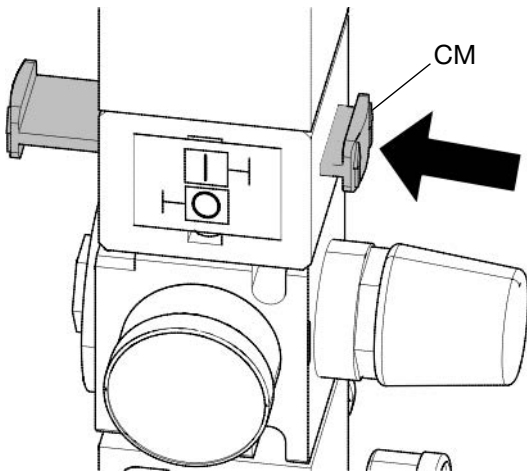

2. Push in the Air Motor Slider Valve (CM) to stop the Pump.

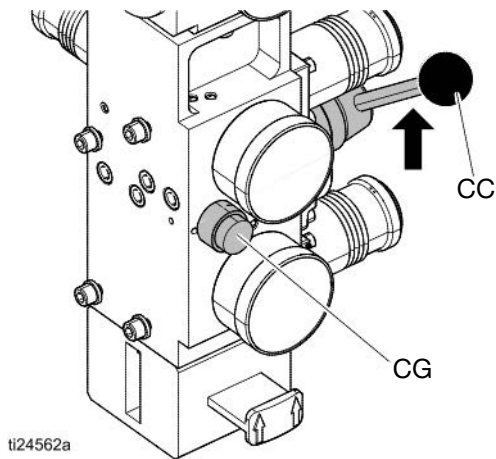

6. Inspect Platen and if necessary, remove any remaining material or material build-up.
7. Follow steps in **Load Material**, page 29, and **Prime Pump**, page 31.

3. Set Ram Director Valve (CC) to UP and raise the Platen (G) and immediately press and hold the Blowoff Buttons (CG) until the Platen is completely out of the pail. Use the minimum amount of air pressure necessary to push the Platen out of the pail.



				
<p>Excessive air pressure in the material pail could cause the pail to rupture, causing serious injury. The Platen must be free to move out of the pail. Never use pail blowoff air with a damaged pail.</p>				

4. Release the blowoff air button and allow the Ram to rise to its full height.
5. Remove the empty pail.

Troubleshooting





Light Tower (Optional)

Signal	Description
Red Light Off	If green light is also off, system power may be off or system operating mode is Inactive. If green is on or flashing, there are no active errors
Red Light On	User interaction required — alarm, system is shut down
Red Light Flashing	User interaction required — advisory, deviation, or system is in a state that could prohibit dispensing
Green Light Off	System is inactive
Green Light On	System is ready to dispense. The heat and Pump are on.
Green Light Flashing	System will be ready to dispense in time without user interaction (heat on, Pump off, and temperature control zones have not reached set point)

Error Codes

There are three types of errors that can occur. Errors are indicated on the display as well as by the optional Light Tower.

Alarms are indicated by . This condition indicates a parameter critical to the process has reached a level requiring the system to stop. The alarm needs to be addressed immediately.

Deviations are indicated by . This condition indicates a parameter critical to the process has reached a level requiring attention, but not sufficient enough to stop the system at this time.

Advisories are indicated by . This condition indicates a parameter that is not immediately critical to the process. The advisory needs attention to prevent more serious issues in the future.

To acknowledge the error, press .

The third digit, or sometimes the last digit of the error code, indicates which unit the error is active on. The “★” (star) character indicates the code applies to multiple system components.

Third or Last Digit “★”	Code Relates To:
A	Unit A
B	Unit B

The last digit of the error code indicates which system component the error applies. The “#” (pound) character indicates the code applies to multiple system components.

Last Digit “#”	Code Relates To System Component:
1	MZLP 1
2	MZLP 2
3	MZLP 3
5	MZLP 5
6	MZLP 6
7	MZLP 7
G	Gateway (CGM)
H	Gateway Heartbeat Loss
V	AWB Unit A
W	AWB Unit B
X	Daughter Board Unit A
Y	Daughter Board Unit B

The last digit of the error code indicates which heat zone the error applies. The “_” (underscore) character indicates the code applies to multiple system components.

Last Digit “_”	Code Relates To Heat Zone:
1	Zone 1
2	Zone 2
3	Zone 3
4	Zone 4
5	Zone 5
6	Zone 6
7	Zone 7
8	Zone 8
9	Zone 9
A	Zone 10
B	Zone 11
C	Zone 12
D	Pump
E	Platen

Code	Description	Type	Cause	Solution
A3MF	AWB Clean Fan Filter	Alarm	Cooling inlet screen is dirty	Clean inlet screen.
A4 _	High Current Unit _ Zone _	Alarm	Defective or shorted to ground on zone	Verify accessory is rated for 240 VAC. Verify heater resistance and check for shorts to ground. Replace as necessary.
A4C#	High Current Fan AWB, Unit _	Deviation	Fan is drawing too much current	Verify there is not an air obstruction at the inlet/outlet of enclosure. Verify nothing is preventing fan rotation. Replace fan if necessary.
A7 _	Unexp. Curr. Unit _ Zone _	Alarm	Unexpected current flow to zone	Replace MZLP. Faulty accessory heater. Measure resistance to ground between heater leads.
A8 _	No Current Unit _ Zone _	Alarm	No Current Flow to the Zone	Verify cable is plugged into zones 3-4. Replace heater if necessary. See MZLP-1 page 14. Check for loose or disconnected wires or plugs. Check for blown fuses on MZLP. Check heater resistance for open circuit. Check for shorts between heater and ground.
A8C	AWB No Fan Current	Alarm	Cooling Fan not Working	Verify fan is plugged in. Replace if necessary.
AM3#	High Current SSR MZLP _	Alarm	Excessive current flow in the SSR	Check for shorts in harness to SSR. Check polarity of wiring to SSR. Replace if necessary.
AM4#	High Current Contactor MZLP _	Alarm	Defective or shorted to ground on MZLP	Check for shorts in the harness to contactor. Check the polarity to contactor. Replace contactor if necessary.
AM8#	No Current Contactor MZLP _	Alarm	No Current Flow to the Contactor	Ensure harness to MZLP is connected. Ensure wiring to contactor is secure. Replace contactor if necessary.
CAC#	Comm Error MZLP _	Alarm	System not responding to ADM	System is not properly loaded with correct Software. Dial not set correct on MZLP. Duplicate MZLP dial positions (i.e. 1 to 1, 2 to 2, ect). Check all CAN connections between the ADM and missing MZLP. Check if hardware exists on the network. Replace MZLP if necessary.
CACX	DB Not Present Unit A	Alarm	Daughter Board not responding	Dial not set correct on MZLP 5. Set to 5 on board with daughter board. Ensure connections between the ADM and hardware are secure. Replace Daughter Board.

Code	Description	Type	Cause	Solution
CCAG	Comm. Error, Gateway	Alarm	CGM Module is no longer responding	Power removed from Gateway. Restore power. Rotary switch on Gateway changed to positions between 2 and 8 (must be in 0, 1, or >8 positions).
CACH	Gateway Heartbeat Loss	Alarm	Heartbeat signal was removed while PLC was controlling the TOF via the CGM	PLC went off line. Field Bus connection to CGM was broken. Restore connection between Field Bus and CGM.
CACY	DB Not Present Unit B	Alarm	Daughter Board not responding	Dial not set correct on MZLP. Set to 4 on board with daughter board. Ensure connections between the ADM and hardware are secure. Replace Daughter Board.
CACV	AWB not present Unit A	Alarm	AWB not responding	Ensure connections between the ADM and hardware are secure. If a tandem system, ensure AWB 2 jumper is installed at startup. Replace AWB.
CACW	AWB not present Unit B	Alarm	AWB not responding	AWB 2 jumper was not in place at start up Ensure connections between the ADM and hardware are secure. Replace AWB.
DA X	Pump Runaway Detected	Alarm	Pump is trying to feed adhesive, no adhesive to feed. Worn or damaged Pump seals	Adjust the drum empty level sensor to detect an empty state. Ensure the Ram Director Valve is in the down position and sufficient air is forcing the Ram down. Melter at incorrect temperature, too low. Check setpoint and set to manufactures recommendation. Inspect Pump seals and replace if necessary
DE X	Reed Switch Failure Detected	Alarm	Reed switch failed	Check that sensor cable is plugged into the daughter board at J16. Check for loose connection at reed switch. Ensure reed switch is securely attached to the Air Motor. Replace if necessary.

Code	Description	Type	Cause	Solution
DC X	Pump Diving	Alarm	Pump is trying to feed adhesive, no adhesive to feed.	Adjust the drum empty level sensor to detect an empty state.
				Ensure the Ram Director Valve is in the down position and sufficient air is forcing the Ram down.
			Worn or damaged Pump seals	Melter at incorrect temperature, too low. Check setpoint and set to manufactures recommendation. Inspect Pump seals and replace if necessary
L1 X	Material Level Sensor Error	Alarm	Machine is detecting an empty state without a low state	Make sure the empty level sensor is not covered in material
				Verify the low level sensor is plugged into J15 of the daughter board. Verify the low level sensor is close enough to the metal bar; adjust if necessary.
				Replace sensors.
L2 X	Material Level Empty	Alarm	Material drum is empty	Replace material container. If more material is leftover, lower the empty level sensor.
L3 X	Material Level Low	Deviation	Material level is low	Replace at appropriate time.
MMUX	USB Log Full	Advisory	USB logs fulls. Data loss will occur if not downloaded.	Download USB data or disable the USB log errors on the Advanced screen 3.
MN X	Pump _ Requires Maintenance	Advisory	User defined Pump maintenance counter has run out	Perform Pump maintenance, then reset the counter on the maintenance setup screen.
Ta★	Over Temperature Switch	Alarm	An over temperature switch has opened.	Check Heat Rate Option on Advanced Screen 2 to make sure it is set to Normal or Slow. If set to Fast, the switch will open on the pump or platen.
				If “_” is 9, A, B, or C, make sure jumper 16W035 is installed in J5 on MZLP 5 and MZLP 7 (for tandem units).
T1 _	Low Temp. Unit _ Zone _	Alarm	Zone temperature too low	Reduce flow rate.
				Increase temperature of accessory upstream.
				Faulty accessory heater measure resistance between heater leads.
				Change Low Temp Alarm Offset. Replace accessory.
T2 _	Low Temp. Unit _ Zone _	Deviation	Zone temperature too low	Reduce flow rate.
				Change Low Temp Deviation Offset.
				Add zone (temperature) upstream.

Code	Description	Type	Cause	Solution
T3 _	High Temp. Unit _ Zone _	Deviation	Temperature reading has risen too high	Change High Temp Deviation Offset.
				Verify setpoint upstream is not hotter than this zone's setpoint.
T4C#	AWB Temperature Runaway Transformer	Alarm	Cooling fan not working or inlet is blocked/dirty	Ensure inlet and outlets are not obstructed.
				Verify fan is plugged in.
T4M#	AWB High Transformer Temp	Alarm	Transformer Temperature is too High	Ensure inlet and outlets are not obstructed.
				Verify fan is plugged in.
T4 _	High Temp. Unit _ Zone _	Alarm	Temperature reading has risen too high	Change High Temp Alarm Offset.
				Verify setpoint upstream is not hotter than this zone's setpoint.
T6 _	Sensor Err. Unit _ Zone _	Alarm	Bad RTD Reading	Check RTD wiring and harness/connector integrity.
				Replace RTD.
T6C#	AWB Invalid Thermistor Reading	Alarm	Transformer thermistor temperature is incorrect	Verify thermister is securely connected to J7 of the AWB. Replace transformer if necessary.
T8V_	No Temp. Rise Unit _ Zone _	Alarm	Temperature reading does not change.	Check fuses on MZLP connected to that Zone.
				Check wiring to device.
				Check heater resistance on device.
V1 #	Low CAN Voltage, MZLP _	Alarm	Bad or overloaded Power Supply	Verify Power Supply voltage is 24 VDC. If voltage is low, disconnect the power lines and re-check voltage reading. If voltage is still low, replace Power Supply. If voltage is correct after disconnecting the power lines. Connect items one at a time until the voltage drops to isolate the bad module.
V1M#	Low Voltage Line AWB, Unit _	Deviation	The voltage to the AWB is below threshold	Verify Transformer voltage top matches incoming voltage. Verify incoming voltage is correct.
V4 #	High CAN Voltage, MZLP _	Alarm	Bad or overloaded Power Supply	Verify Power Supply voltage is 24 VDC. If voltage is high, replace Power Supply unit.
V6M#	Wiring Error Line MZLP _	Alarm	Incoming power is wired incorrectly	Correct the Wiring.

Code	Description	Type	Cause	Solution
V8M#	No Line Voltage MZLP _	Alarm	Incoming line voltage is less than 100 VAC.	Verify Transformer has the correct tap selected.
				Verify CB-1 or FU-4, FU-5, and FU-6 are not tripped/blown.
				Verify RCD-1 is not tripped.
				Measure incoming power with system unplugged. If line voltage is less than 100 VAC, contact qualified electrician to correct the low voltage.
	Verify the MZLP is plugged in at J2 and the AWB is plugged in at J5 or J6.			
V4M#	AWB High Line Voltage	Alarm	Incoming voltage is too high	Check incoming voltage is correct for configuration.
				Verify the transformer has the correct tap (400, 480, 600) selected.
WJ1	Pump _ Solenoid is disconnected	Alarm	Pump is not turning on when it should	Verify harness is plugged into J13 of the daughter board. Verify it is secured to the solenoid.
				Replace Solenoid.
WJ2	Pump _ Solenoid High Current	Alarm	Solenoid is drawing too much current	Inspect for short in harness. Inspect for a shorted solenoid cable/short to the ground. Replace solenoid.
WSUX	Configuration Error USB	Advisory	USB configuration is not loaded	Install software.

Ram Troubleshooting

Problem	Cause	Solution
Ram will not raise or lower.	Closed main air valve or clogged air line,	Open air valve; clear air line.
	Not enough Ram air pressure.	Increase Ram air pressure.
	Worn or damaged Ram piston.	Replace piston. See 55 Gallon, 16 Gallon, and 5 Gallon Ram Modules, Repair - Parts manual 334198.
	Platen not fully up to temperature.	Wait for full temperature.
	Ram air pressure too high.	Decrease Ram air pressure.
	Dented drum has stopped Platen.	Fix or replace drum.
Ram raises or lowers too fast.	Ram "up / down" air pressure too high.	Decrease Ram air pressure.
Air leaks around cylinder rod.	Worn rod seal.	Replace o-rings in guide sleeve. See 55 Gallon, 16 Gallon, and 5 Gallon Ram Modules, Repair - Parts manual 334198
Fluid squeezes past Platen wipers.	Ram air pressure too high.	Decrease Ram air pressure.
	Worn or damaged wipers.	Replace wipers.
Pump will not prime properly, or pumps air.	Closed main air valve or clogged air line.	Open air valve; clear air line.
	Not enough air pressure.	Increase air pressure.
	Worn or damaged Ram piston.	Replace piston. See 55 Gallon, 16 Gallon, and 5 Gallon Ram Modules, Repair - Parts manual 334198.
	Ram directional valve closed or clogged.	Open valve; clear valve or exhaust.
	Ram directional valve dirty, worn, or damaged.	Clean; repair valve.
	Directional valve not in the down position.	Position handle in the down position.
	Dented drum has stopped Platen.	Fix or replace drum.
Air pressure will not push Platen out of drum.	Closed main air valve or clogged air line.	Open air valve; clear air line.
	Platen not fully up to temperature.	Wait for full temperature.
	Not enough blow-off air pressure.	Increase blow-off air pressure.
	Blow-off valve passage clogged.	Clean valve passage.
	Dented drum has stopped Platen.	Fix or replace drum.
	Wipers bonded to drum or drum liner.	Lubricate wipers with high temperature grease at every drum change.

Heated Pump Troubleshooting

See Pump manual for additional Pump troubleshooting information. See **Component Identification**, page 8.

Problem	Cause	Solution
Rapid downstroke or upstroke (Pump cavitation).	Material not heated to proper temperature.	Check and adjust temperature to proper setpoint. Wait for Pump/Platen to heat up.
	Air is trapped in Pump.	Bleed air from Pump. See Prime Pump , page 31.
	Downstroke: Dirty or worn Pump intake valve.	Clean or repair. See Pump Manual.
	Upstroke: Dirty or worn Pump piston valve.	Clean or repair.
	Machine is out of material	Adjust empty level sensor.
Material leaks around Pump outlet.	Loose outlet fitting.	Tighten outlet fitting.
Material leaks around bleed port.	Loose bleed port fitting.	Tighten bleed port fitting.
Pump will not move up and down.	Problem with Air Motor.	See Air Motor Manual.
	Foreign object lodged in Pump.	Relieve pressure. See Pump Manual.
	Platen not fully up to temperature.	Wait for full temperature.
	Valve to Air Motor is off.	Check gauges and valves to the Air Motor.
Leak around Pump wet-cup.	Worn throat seals.	Replace throat seals. See Servicing the Throat packings in manual 334127 or 334128.

Air Motor Troubleshooting

See Air Motor manual for additional Air Motor troubleshooting information. See **Component Identification**, page 8.

Problem	Cause	Solution
Air motor will not run.	Air motor solenoid is off.	Wait for heat zones in use to reach temperature setpoint values.
Air motor stalled.	Damaged main air valve spool or poppets.	Inspect and clean poppets. See Air Motor Manual.
		Rebuild main air valve. See Air Motor Manual.
Air continuously exhausting around Air Motor shaft.	Damaged Air Motor shaft seal.	Replace Air Motor shaft seal. See Air Motor Manual.
Air continuously exhausting around air valve/slide valve.	Air valve/slide valve gasket is damaged.	Replace the valve gasket. See Air Motor Manual.
Air continuously exhausting from muffler when motor is idle.	Internal seal damage.	Rebuild Air Motor. See Air Motor Manual.
Icing on muffler.	Air motor operating at high pressure or high cycle rate.	Reduce pressure, cycle rate, or duty cycle of motor.

Repair

Replace Wipers

1. To replace a worn or damaged wiper raise the Ram plate up out of the drum. Perform steps 1 through 7 of **Change Pail**, page 37.
2. Separate the wiper joint, and bend back the strapping that covers the clamp (207).
3. Unscrew the worm gear and remove the wiper (202).
4. Thread the strapping through the new wiper (202).
5. Insert the strap end through the clamp (207) and tighten.
6. Use a rubber mallet to pound the wiper around the Platen (201) until the wiper ends are butted tightly together.
7. Apply a lubricant to the wiper (202). Use a lubricant that is compatible with the material to be pumped. Check with the material supplier.

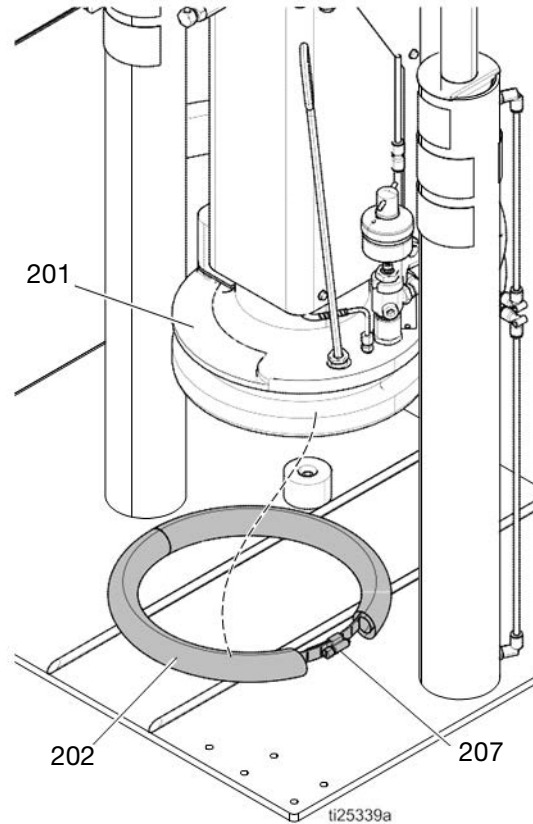

FIG. 27:

Replace Platen RTD



Reference **Electrical Schematics**, page 61, for wiring connections.

1. If the material pail has already been removed from the supply unit, go to step 2. If you need to remove the material pail, see **Change Pail**, page 37.
2. Make sure the Ram plate is down and the Ram Director Valve is in the OFF position.

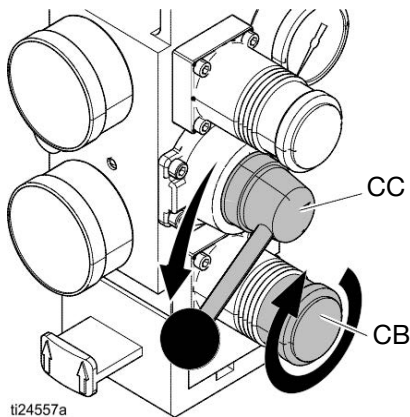

To reduce the risk of injury or damage to equipment, make sure the Main Power Switch is off before continuing with this procedure.

3. Turn the Main Power Switch OFF.



4. Remove the front and right side Pump cover.

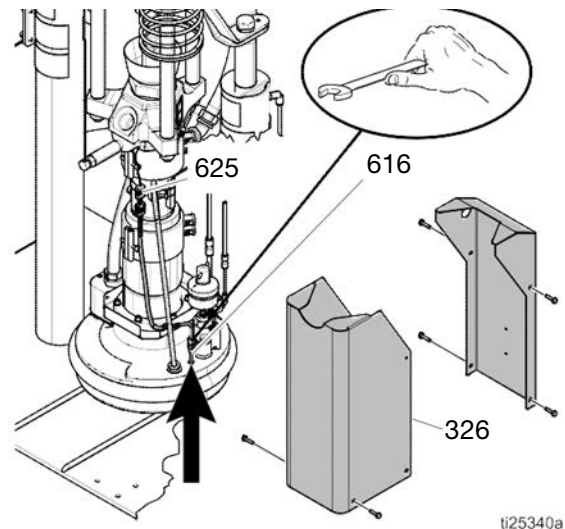

FIG. 28:

5. Remove the Platen RTD (616) from the Platen.
6. Disconnect the Platen RTD quick connect terminal (625) from J5 connector on MZLP MZTCM-1 or MZTCM-5.
7. Attach the leads from the new sensor (616) to the leads of the old sensor and pull the new sensor leads through the cable Pump shield, Cable Track, and into the Electrical Enclosure.
8. Install the new sensor (616) into the follower/tire plate after coating with non-silicone heat sink compound. Tighten compression nut. Ensure RTD is fully inserted.
9. Reconnect the quick connect terminal (625).
10. Replace the Pump covers.

Separate the Air Motor and Pump



This procedure must be done with the unit still warm. The material and equipment will be hot!

1. If the material drum has already been removed from the supply unit, go to step 2. If you need to remove the material pail, perform steps 1 through 6 of the **Change Pail** section, page 37. Pump must be in the full down position (Air Motor shaft fully extended).
2. Make sure the Ram plate is down and the Ram Director Valve (CC) is in the neutral position.

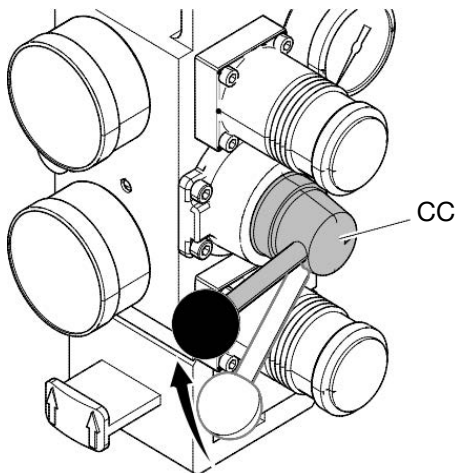

3. Follow **Pressure Relief Procedure** on page 34.
4. Bleed off excess material and pressure in the system by opening the dispense gun and catching the material in a waste container.
5. On the ADM, turn off the system heat (D).
6. Turn the Main Power Switch OFF.



7. Disconnect all material hoses.

8. If the system includes a Pump shield, remove the Pump sheet metal enclosure (A). See FIG. 29.
 - a. Remove the cover screws (B).
 - b. Remove the heater bands (HB) and disconnect the ground wire (R).
9. Pump must be in the full down position (Air Motor shaft fully extended).
10. If vent hood is installed, remove it.
11. Disconnect the electrical cable from the Air Motor (X).
12. Remove the air line from the Air Motor and air lines to the follower blow-off valve.
13. Remove nuts (F) from Pump/Air Motor tie rods at the Pump end.
14. Remove the nuts and bolts (T) holding the cable tract to the Air Motor support plate. Slide the end of the Cable Track outboard of the mounting plate.
15. Remove the screws and the washers from the Pump inlet.
16. Fully loosen the Pump rod coupler (G) to the Air Motor rod.
17. Slowly raise the elevator to achieve enough separation of the Pump (Air Motor) tie rods to remove the Pump.
18. Remove the Pump (P).
19. Reverse this procedure to reinstall the new or rebuilt Air Motor.

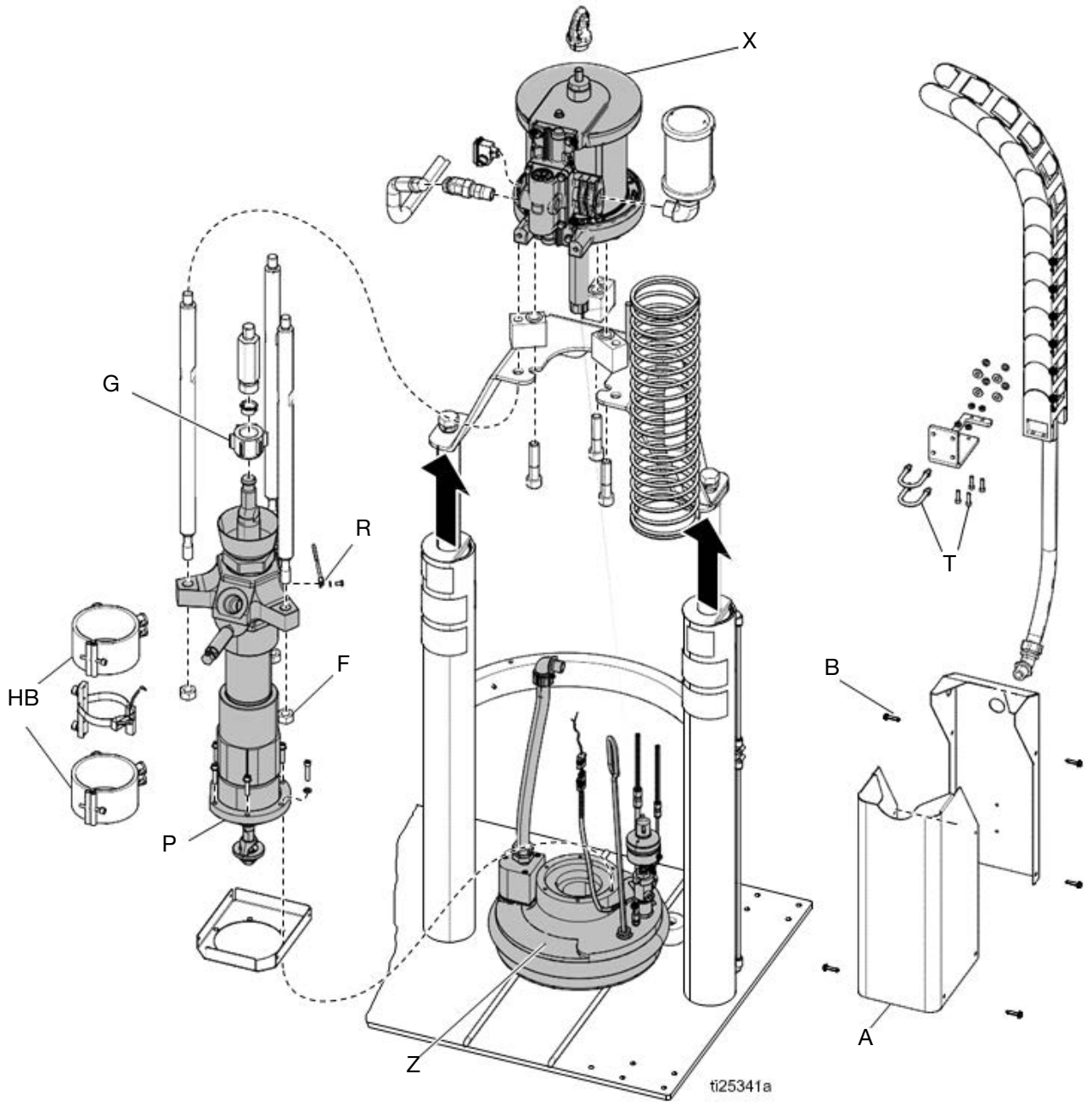

FIG. 29

Remove Platen



1. Turn the Main Power Switch OFF.
2. Disconnect the Platen power wires and the ground wire from within the main Control Panel and pull out of conduit.
3. Remove the Platen assembly from the Ram.
4. Reverse this procedure to reinstall the new or rebuilt Platen assembly.

Replace Heater Band and Pump RTD



Replace Heater Band

1. If the material drum has already been removed from the supply unit, go to step 2. If you need to remove the material drum, perform steps 1 through 6 of the **Change Pail**, page 37. Pump must be in the full down position (Air Motor shaft fully extended).
2. Make sure the Ram plate is down and the Ram Director Valve is in the neutral position.
3. Follow the **Pressure Relief Procedure**, page 34.
4. Bleed off excess material in the system by opening the applicator and catching the material in a waste container.
5. On ADM, turn off the system heat (D).
6. Turn the Main Power Switch OFF.



7. Remove the Pump covers.

8. Remove the white ceramic caps and disconnect the electrical wires from the heater band (309a, 309b).
9. Remove the screw that holds the heater band in place.
10. Remove the heater band (309a, 309b) from the Pump.
11. Coat the inside of the heater with a non silicone heat sink compound before mounting. Maximum thickness is 0.005 in. Coat only to within 3/4 in. of vertical ends.
12. Install a new heater band (309a, 309b) in the same location as the old heater band:
 - a. Locate heater terminals so they line up with the back of the Pump.
 - b. Tighten the heater band.
 - c. Re-connect the heater wires and re-attach the ceramic caps that insulate the terminal.

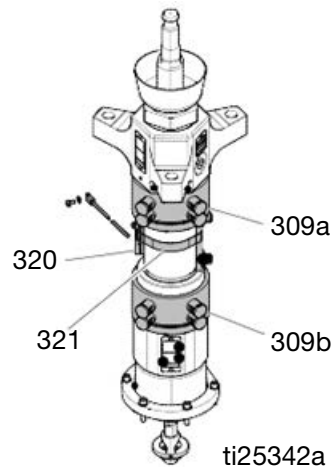
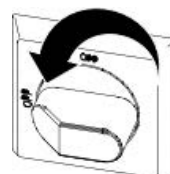

FIG. 30

Replace Pump RTD

1. Turn the Main Power Switch OFF.



2. Remove the screws that hold the front shroud in place and remove the front shroud.
3. If the sensor wire is connected to the electrical enclosure, disconnect it.
4. Loosen the clamp (321) holding the sensor on the Pump.
5. Tie the leads of the new sensor (320) to the old sensor and remove the old sensor. The leads of the new sensor will be easily drawn through the conduit for reconnecting.
6. Replace the sensor (320) in the clamp (321):
 - a. Place the sensor approximately 30° counter clock-wise from the Pump outlet.
 - b. Tighten the clamp (321).
7. Re-connect the sensor wire to the electrical enclosure.

NOTICE

To prevent system damage, always use fast acting fuses. Fast acting fuses are required for short-circuit protection.

1. Turn the Main Power Switch OFF.



2. Open electrical enclosure door.
3. Use a proper non-conductive fuse puller tool to remove the blown fuse.

NOTICE

Using an improper tool, such as screw drivers or pliers, may break the glass on the fuse.

Replace MZLP Fuse



Each MZLP module comes with the following fuses:

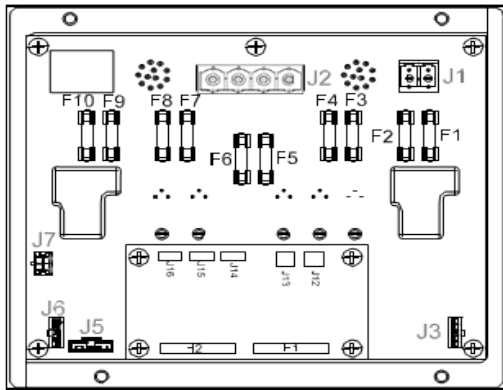

FIG. 31: Fuse Locations

NOTE: F1 and F2 are white ceramic and indicate 25A on the barrel.

NOTE: F3-F10 are clear glass and indicate 8A on the barrel.

4. Use a proper non-conductive fuse puller tool to install the new fuse.

NOTICE

Using an improper tool, such as screw drivers or pliers, may break the glass on the fuse.

5. Close the electrical enclosure.

Fuse Kit	Fuse	Part
24V289	F1, F2	250VAC, 25A, long, white ceramic
	F3-F10	250VAC, 8A, fast acting, clear glass
	Spare fuse kit included with system.	

Replace MZLP



1. Turn the Main Power Switch OFF.



2. Disconnect the heated hose electrical connectors from the MZLP (111 or 112).
3. Note the location of each cable, then unplug all cables from the MZLP (111 or 112) that will be replaced.
4. Remove the four screws (115) securing the MZLP (111 or 112) to the electrical enclosure, then carefully remove the MZLP from the electrical enclosure.

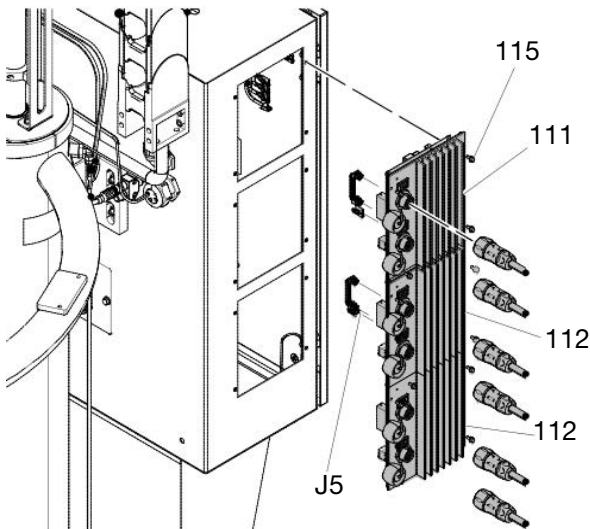

FIG. 32: MZLP Identification

5. Replace MZLP.
 - a. To replace MZLP #1, remove the daughter card and standoffs, and re-install them on the new MZLP #1.
 - b. To replace MZLP #2 of #3, remove the jumper (162) from MZLP #2 or #3 J5 connector and reinstall it on the new MZLP J5 connector.

6. To reassemble the MZLP, set the MZLP rotary switch based on location. See **Table 10 MZLP Rotary Switch**.
7. Use the four screws (115) to install the MZLP (111 or 112) to the electrical enclosure.
8. Reconnect the cables to the MZLP.

NOTE: Do not force the electrical connection. Minimal force is required to seat the connector. If resistance is felt, stop and verify the connector orientation.

NOTE: If unable to determine the connector location, see **Electrical Schematics**, page 61.

9. Connect the heated hose electrical connectors to the new MZLP.

NOTE: The MZLP may need updated software. See **Update Software**, page 60.

Table 10 MZLP Rotary Switch

MZLP	System	Rotary Switch
#1 with Daughter Card	Primary	1
	Secondary	5
#2	Primary	2
	Secondary	6
#3	Primary	3
	Secondary	7

Replace MZLP Daughter Card



1. Turn the Main Power Switch OFF.

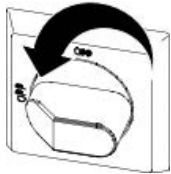

2. Note the location of each cable, then unplug all cables from the MZLP daughter card on MZLP #1 (112).
3. Remove the four mounting screws (112b) from the daughter card (112a) and set aside.
4. Unplug the daughter card (112a) from MZLP #1 (112).

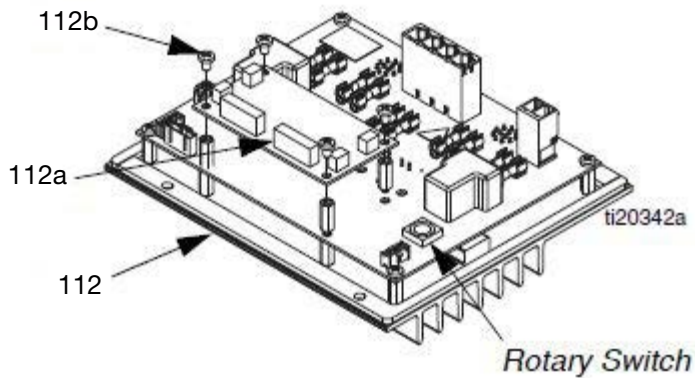

FIG. 33: MZLP Daughter Card

5. Plug the new daughter card (112a) into the MZLP (112).
6. Use the screws (112b) to secure the daughter card to the MZLP (112).
7. Connect the cables to the new daughter card (112a).

NOTE: Do not force the electrical connection. Minimal force is required to seat the connector. If resistance is felt, stop and verify the connector orientation.

NOTE: If unable to determine the connector location, see **Electrical Schematics**, page 61.

Replace AWB



1. Turn the Main Power Switch OFF.



2. Note the location of each cable, then unplug all cables from the AWB (205).

NOTE: For an AWB on a secondary system, remove the connector (182) and connect to the new AWB.

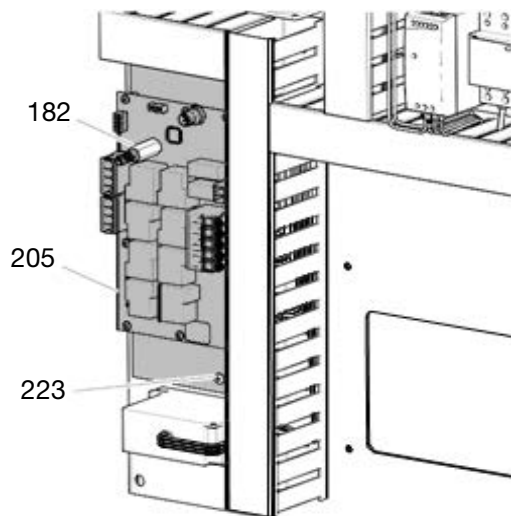

FIG. 34: AWB Connections

3. Remove the two screws (223) securing the AWB (205) to the electrical panel, then carefully remove the AWB.
4. Install the new AWB (205) and reconnect the cables.

NOTE: Do not force the electrical connection. Minimal force is required to set the connector. If resistance is felt, stop and verify the connector orientation.

NOTE: See **Electrical Schematics**, page 61, if unable to determine the connector location.

Replace Power Supply

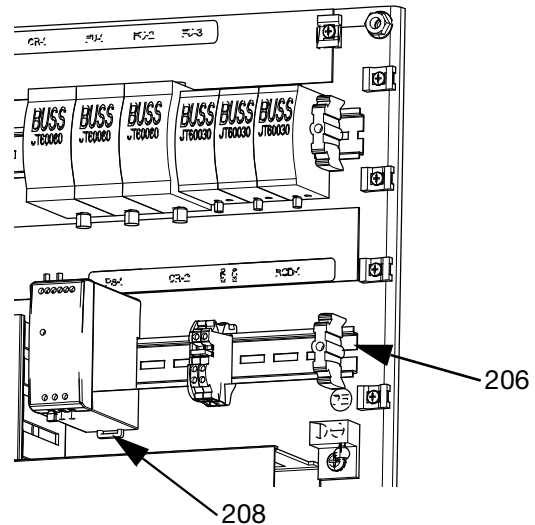

1. Turn the Main Power Switch OFF.

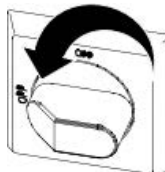

2. Open the electrical enclosure.
3. Remove the Power Supply (208) from the din rail (206). Disconnect the screw terminal connections between the Power Supply and the Power Supply harness.

Power Supply Connection	Harness Label
V+	V+
V-	V-
GND	GND
L	L
N	N

4. Connect the Power Supply harness to the new Power Supply.
5. Reattach the Power Supply to the din rail (206).
6. Torque terminals to 4.53-6.2 in-lbs (0.5-0.7 N•m).
7. Close the electrical enclosure door.

Replace Fan



1. Turn the Main Power Switch OFF.



2. Disconnect the plug from the power outlet or turn off the Circuit Breaker for incoming power.
3. Open the electrical enclosure door.
4. Remove the connector from the J7 connector on the AWB board. Remove the red (+) and black (-) fan wires from the connector.

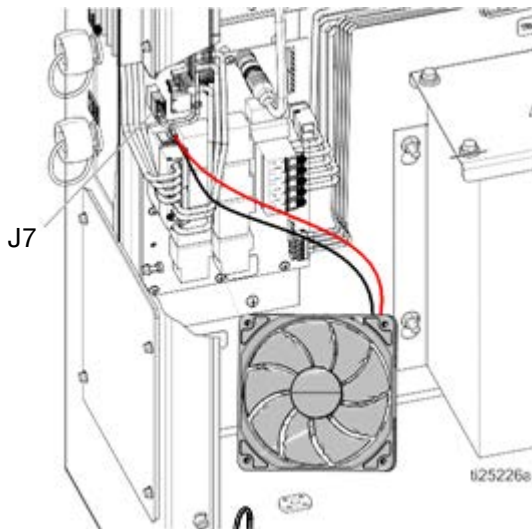

5. Cut any cable ties between the end of the fan wires to the fan (136).

6. Remove the screws (141), grill (137), four nuts (139), rear fan grill (138), and fan (136).

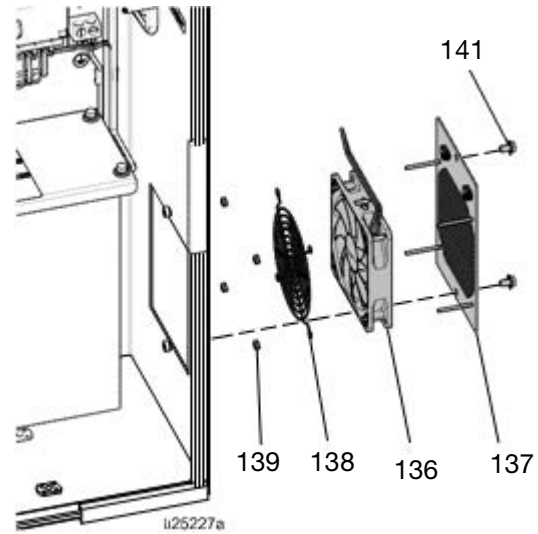

7. Mount the new fan (136), rear fan grill (138), and nuts (139) on the grill (137) with the arrow pointing toward the grill (137).
 8. Tie down the fan wires onto the tie down locations on the grill (137) using cable zip ties.
 9. Route the fan wires into the electrical enclosure. Connect the red and black fan wires to the J7 connector. Reconnect the J7 connector to the AWB. Use cable ties to secure the fan wires to other cables in the electrical enclosure.
- NOTE:** To prevent fan errors on the ADM, remove the excess slack and ensure that the cabling and zip ties do not contact the fan blades.
10. Reinstall the fan grill (137) and close the electrical enclosure.

Replace Transformer



See FIG. 35, page 59.

1. Turn the Main Power Switch OFF.



2. Open the Electrical Enclosure door.
3. Disconnect the incoming power harness (234) from the top of the transformer (235).
4. Disconnect the transformer (235) output power harness wires.
 - a. On series A through E systems, these wires are labeled: CR2-W1, CR2-W2, CR2-W3, CR2-W4 and they connect to CR-2.
 - b. On series F systems, these wires are labeled, RCD-W1, RCD-W2, RCD-W3, RCD-W4, and they connect to RCD-1.
5. Disconnect the transformer (235) ground wire from the back panel ground lug.
6. Disconnect the red (+) and black (-) wire of the fan from pins 4 and 3 of the J7 connector on the AWB (205). Disconnect the J7 connector from the AWB.
7. Cut the wire zip ties securing the fan wires.
8. Remove the flanged nuts (N) and transformer (235) from the back panel (201).
9. Install the new transformer (235) onto mounting studs on the back panel (201) and secure with flanged nuts (N).
10. Insert the thermal sensor connector from the transformer (235) onto the J7 connector on the AWB (205).
11. Reconnect the red (+) wire from the fan into pin 4 and the black (-) wire into pin 3 of the J7 connector.
12. Install the transformer (235) ground wire onto the ground lug of the back panel (201).

13. Connect transformer output power harness (234) to power terminal connections. Torque to 25–27 in-lbs (2.8–3.1 N•m).

Transformer Output Power Harness Connections, Series A through E Systems Table

Power Harness Wires	CR-2 Connections
CR2-W1	Terminal 1
CR2-W2	Terminal 3
CR2-W3	Terminal 5
CR2-W4	Terminal 44

Transformer Output Power Harness Connections, Series F Systems Table

Power Harness Wires	RCD-1 Connections
RCD-W1	Terminal N
RCD-W2	Terminal 5
RCD-W3	Terminal 3
RCD-W4	Terminal 1

14. Install the incoming power harness (234) to the top of the transformer in the voltage port that is labeled with the same voltage. This number is specified on the machine serial number label.

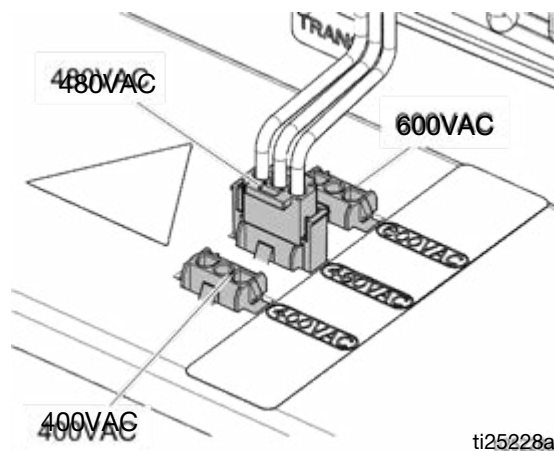

15. Verify all electrical connections, including earth grounds, are complete and tight. All connections and plugs must be connected prior to applying power.
16. Close the Electrical Control Panel door.
17. Apply power to the machine. Turn on the Main Power Switch.
18. Restart the system.

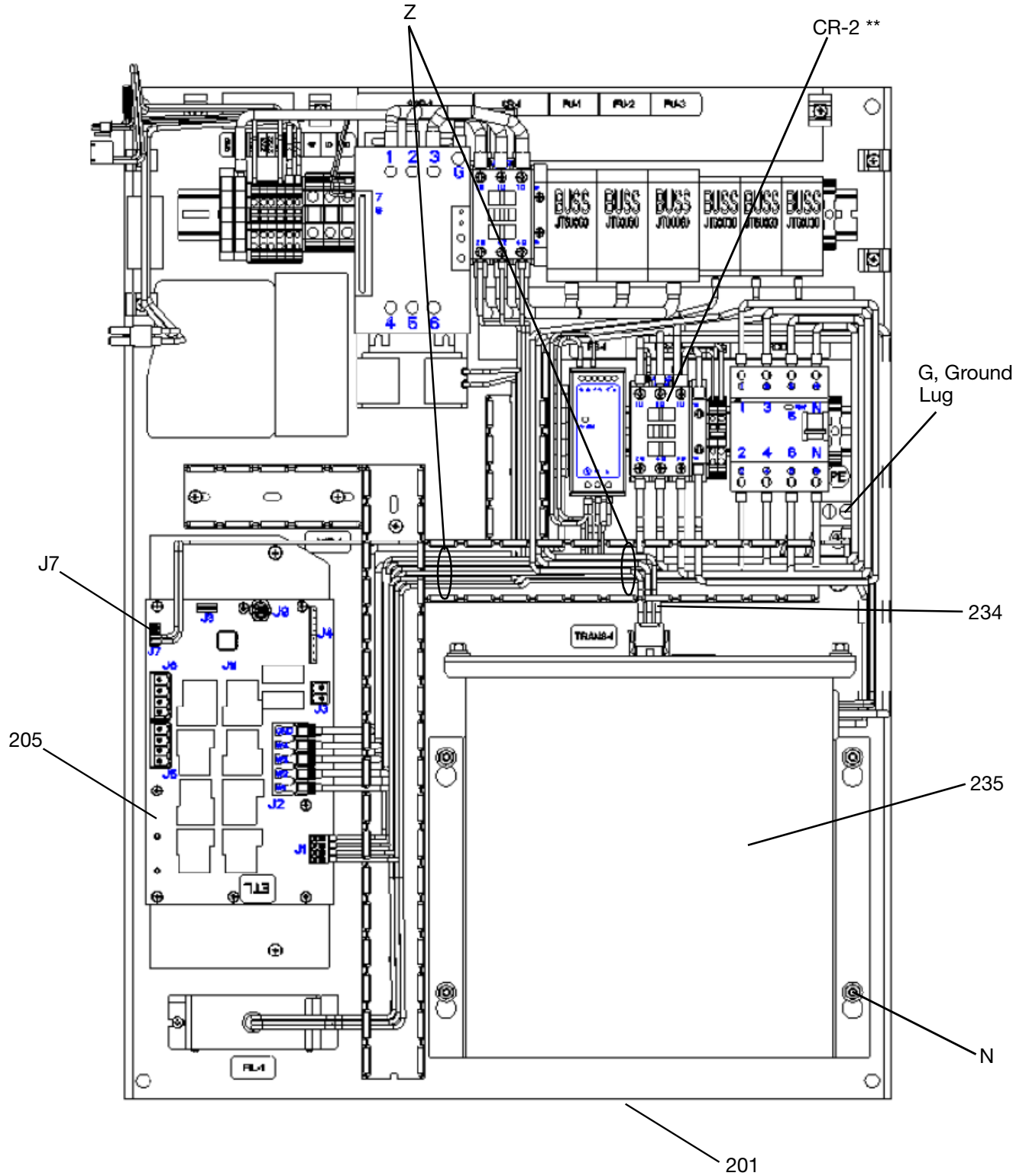

FIG. 35: Inside of Electrical Control Enclosure

** CR-2 device is included on series A through E systems. This component is not included on the series F systems. See notes on **Electrical Schematics** page 61.

Update Software

When software is updated on the ADM, the software is then automatically updated on all connected GCA components. A status screen is shown while software is updating to indicate progress.

1. Turn the system Main Power Switch OFF.
2. Remove the ADM from the bracket.
3. Remove the token access panel.

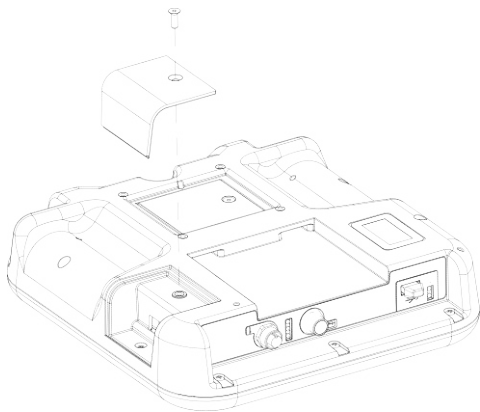

4. Insert and press the software upgrade token (T) firmly into the slot.

NOTE: There is no preferred orientation of the token.

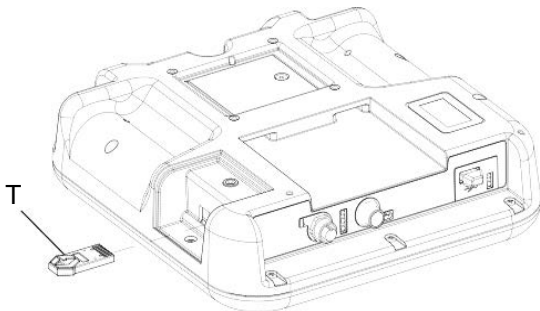

5. Install the ADM into the bracket.
6. Turn the system Main Power Switch ON.

NOTICE

A status is shown while software is updating to indicate progress. To prevent corrupting the software load, do not remove the token until the status screen disappears.

NOTE: When the screen turns on, you will see the following screens:

<p>First:</p> <p><i>Software is checking which GCA modules will take the available updates.</i></p>	
<p>Second:</p> <p><i>Status of the update with approximate time until completion.</i></p>	
<p>Third:</p> <p><i>Updates are complete. Icon indicates update success/failure. See the following Icon table.</i></p>	

Icon	Description
	Update successful.
	Update unsuccessful.
	Update complete, no changes necessary.
	Update was successful/complete, but one or more HCA modules did not have a CAN boot-loader, so software was not updated on that module.

7. Remove the token (T).
8. Replace the token access panel.
9. Press  to continue to the operation screens.

Electrical Schematics

For reference: Use schematic number 17C029S

230V, 3 Phase/60Hz

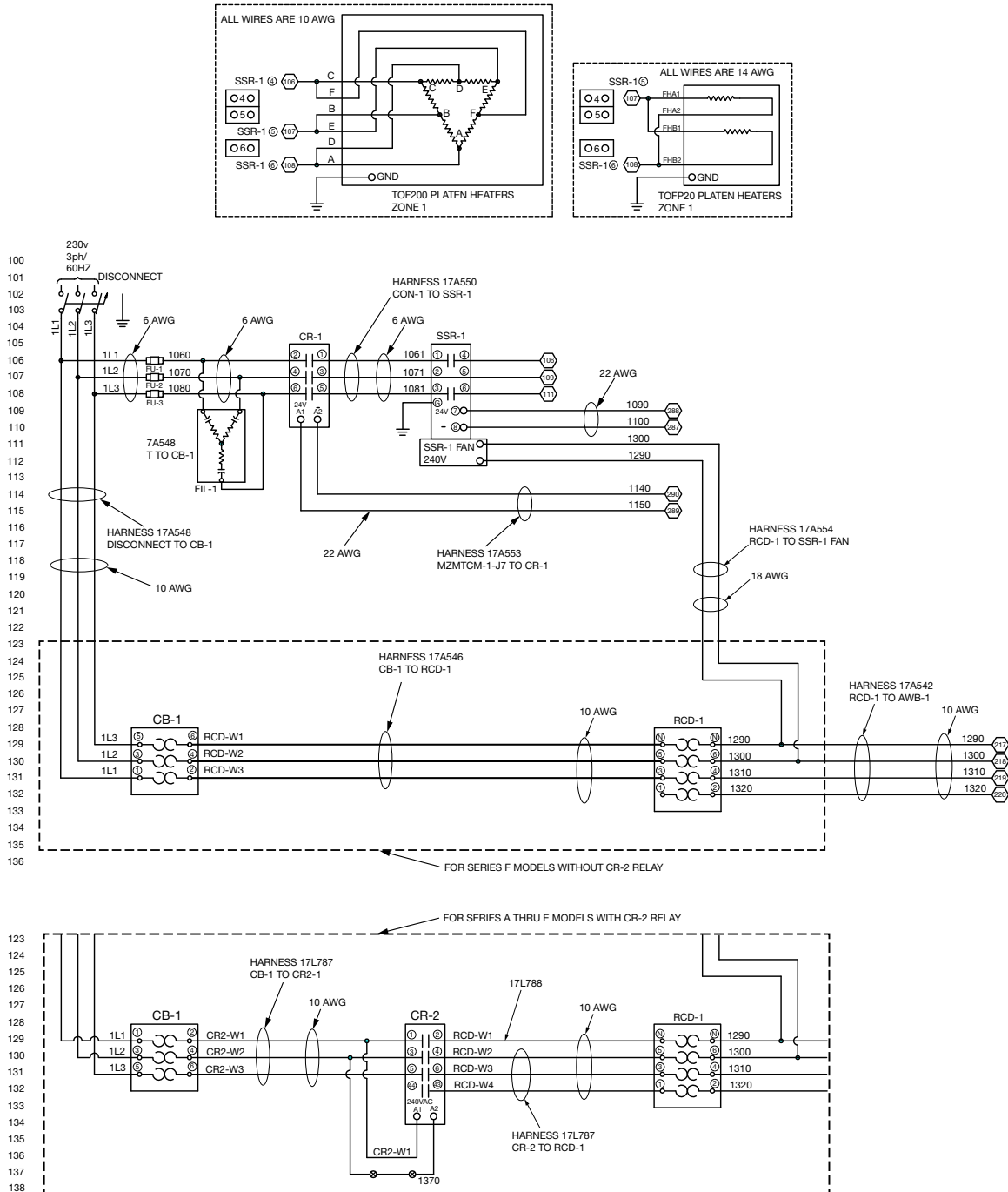

NOTE: CR-2 is no longer available and can be removed rather than replaced according to the schematic above if it malfunctions.

400V, 3 Phase/50Hz

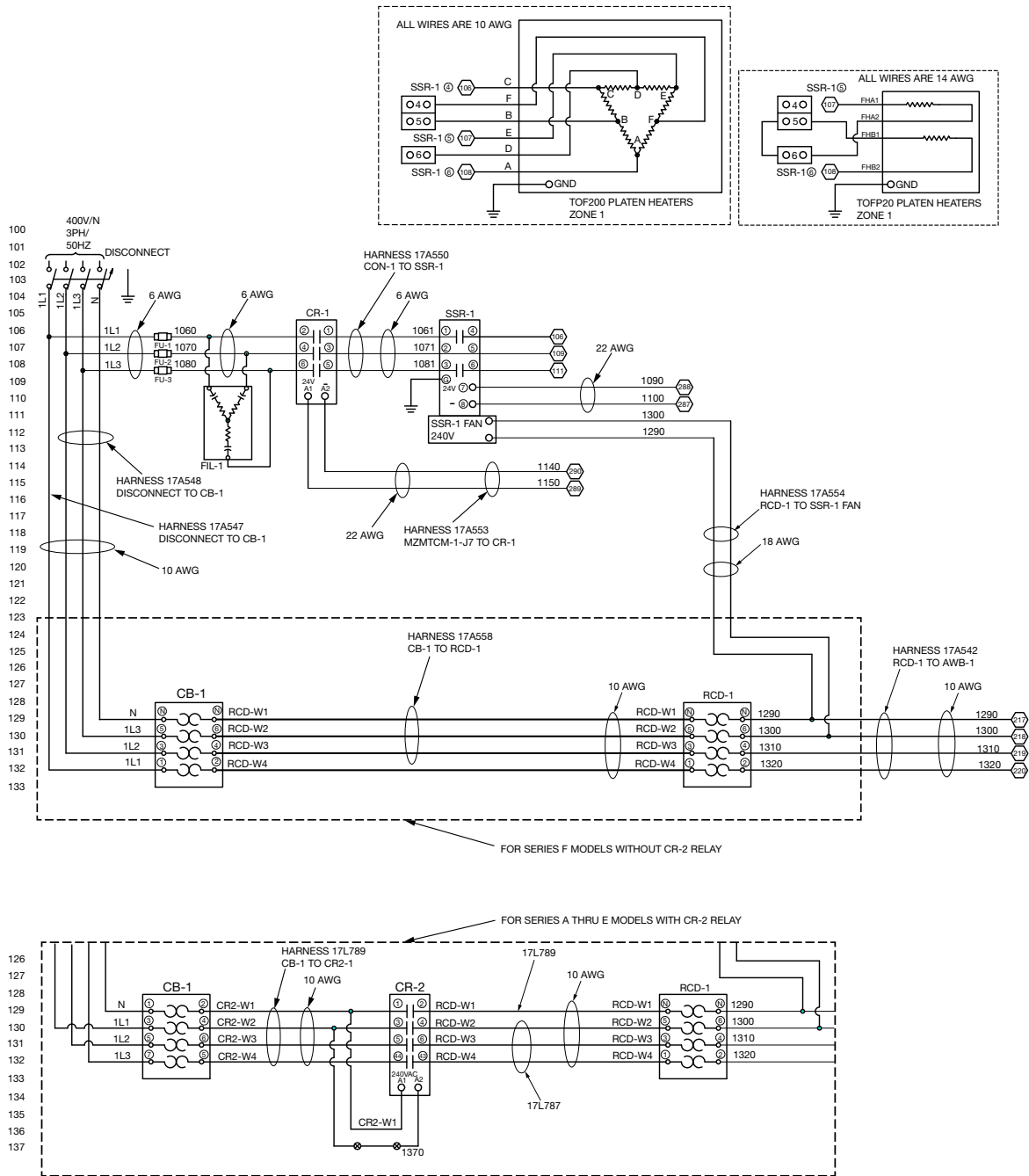

NOTE: CR-2 is no longer available and can be removed rather than replaced according to the schematic above if it malfunctions.

400-600VV, 3 Phase/60Hz

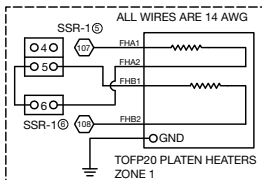
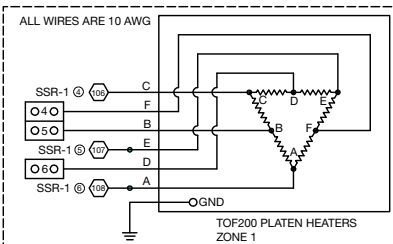
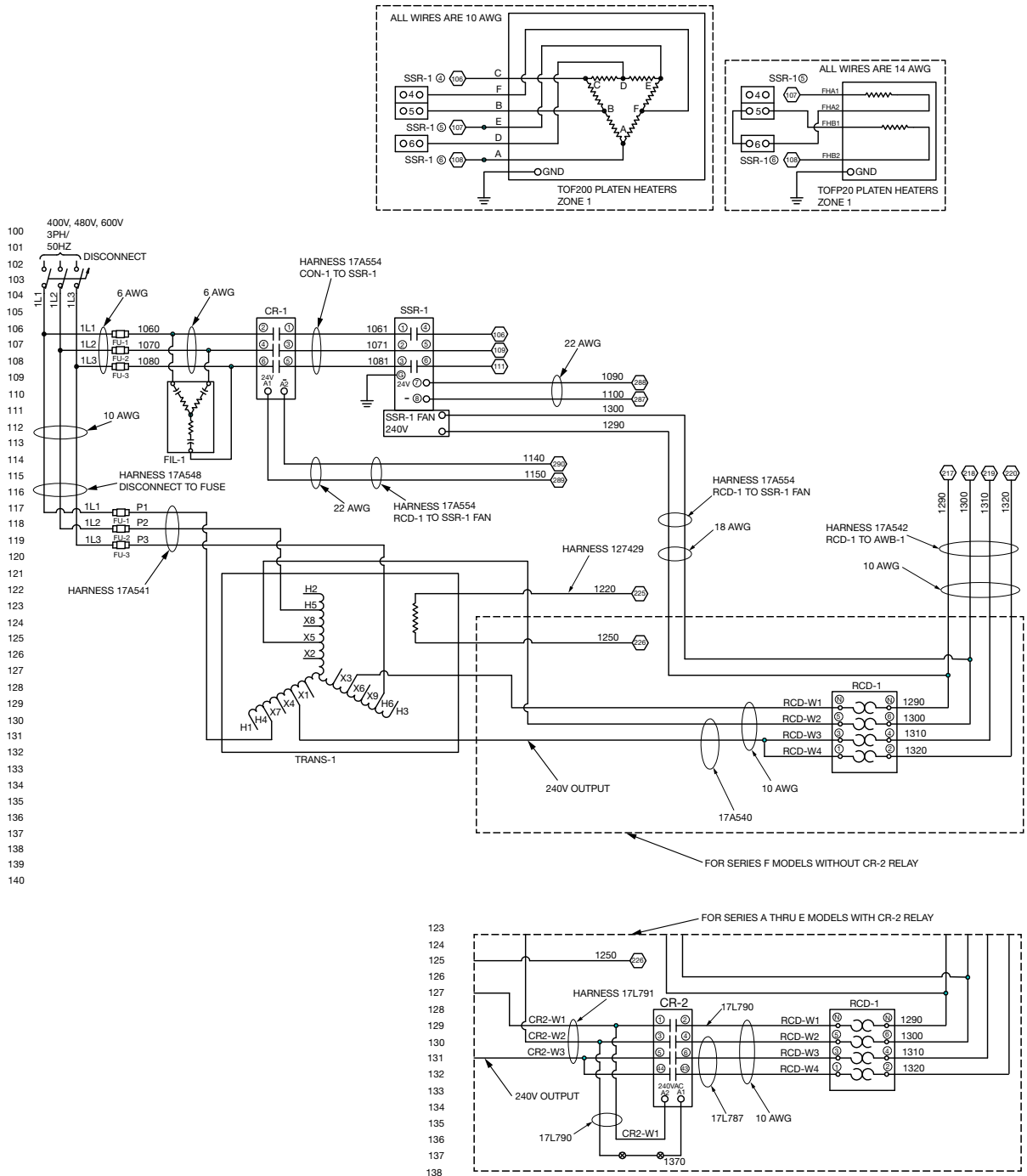

FOR SERIES F MODELS WITHOUT CR-2 RELAY

FOR SERIES A THRU E MODELS WITH CR-2 RELAY

NOTE: CR-2 is no longer available and can be removed rather than replaced according to the schematic above if it malfunctions.

AWB

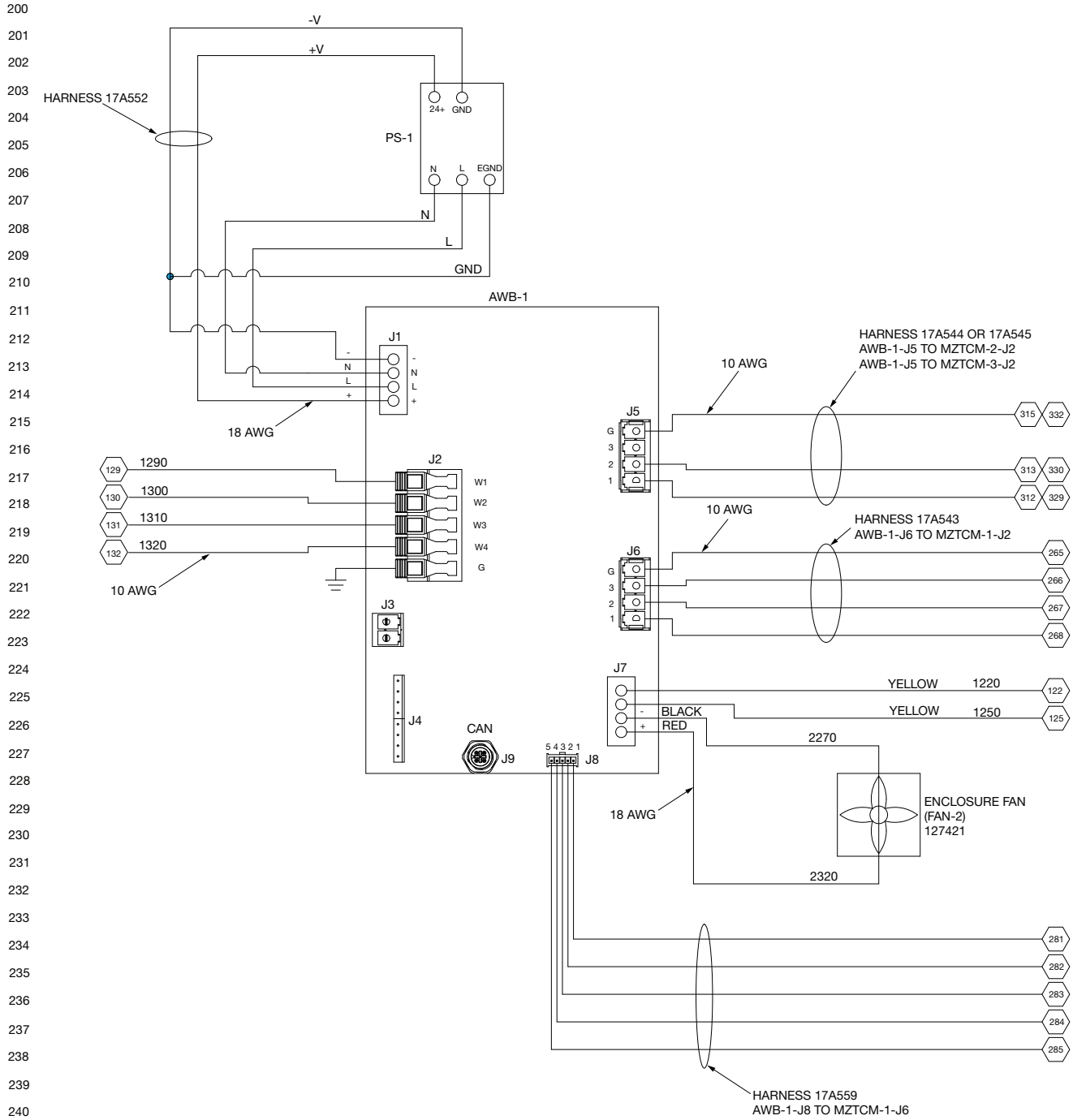

MZLP#1

250
251
252
253
254
255
256
257
258
259
260
261
262
263
264
265
266
267
268
269
270
271
272
273
274
275
276
277
278
279
280
281
282
283
284
285
286
287
288
289
290

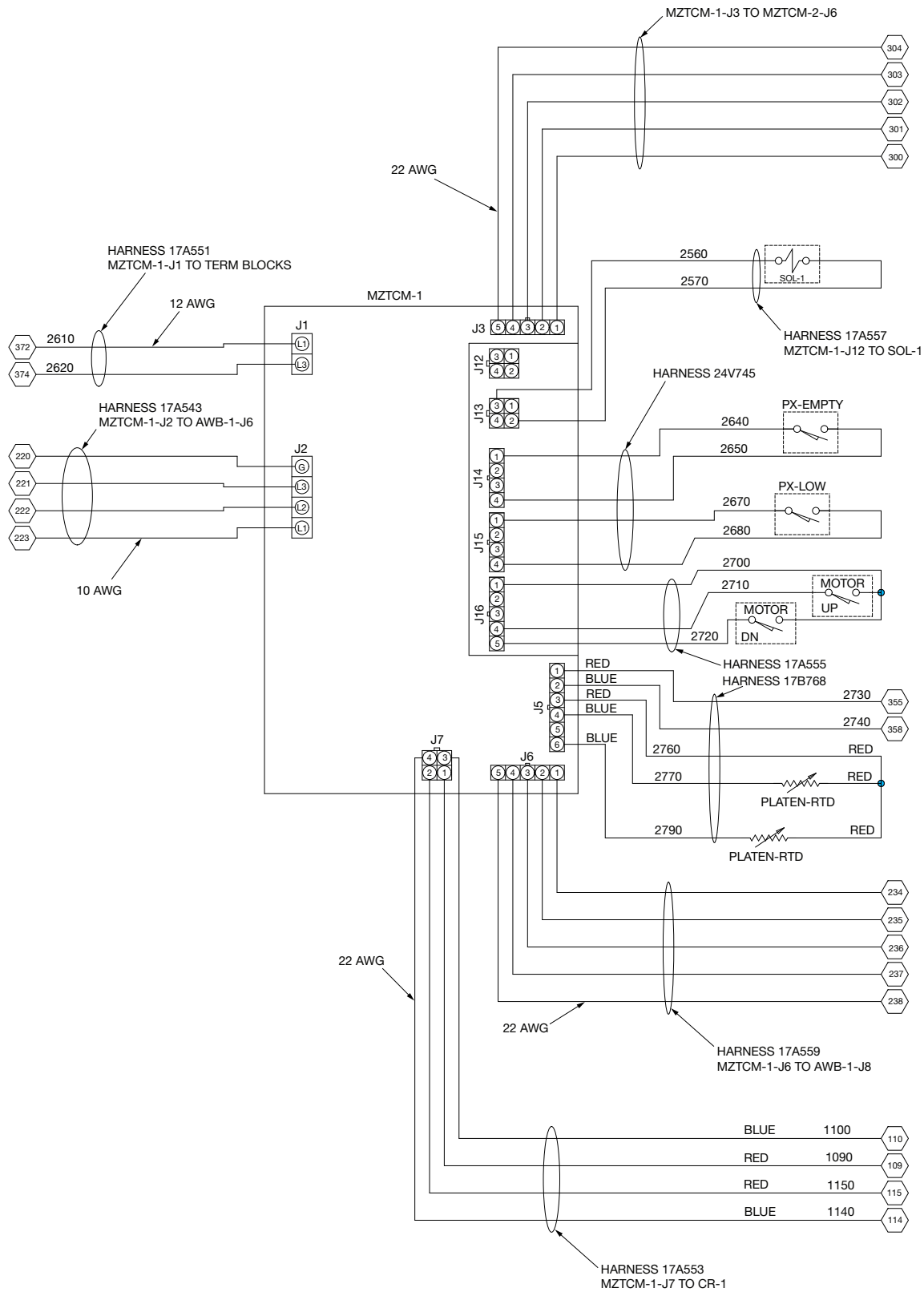

MZLP#2, MZLP#3 Pump Heaters

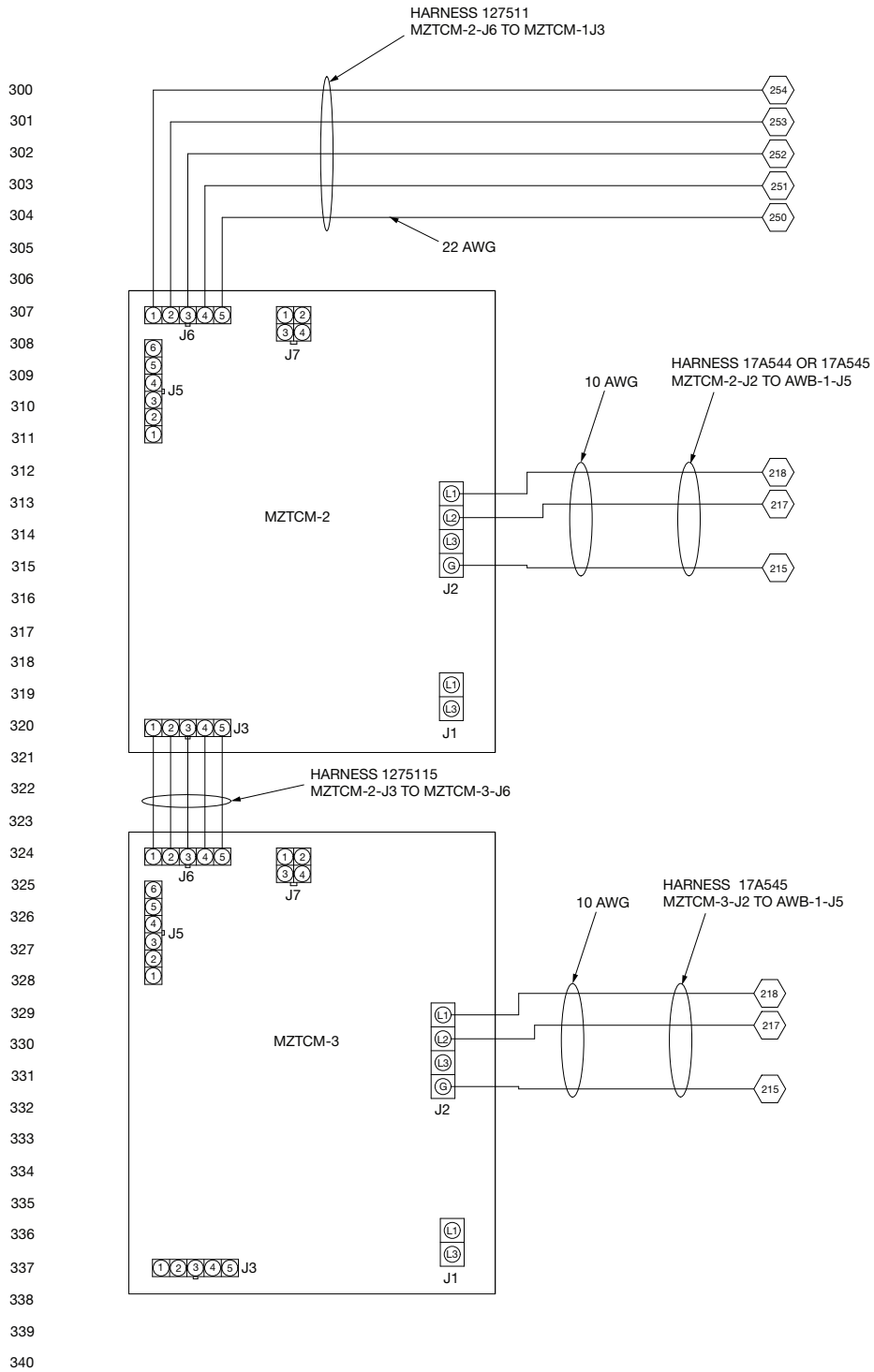

MZLP#2, MZLP#3, Overtemp

350
351
352
353
354
355
356
357
358
359
360
361
362
363
364
365
366
367
368
369
370
371
372
373
374
375
376
377
378
379
380
381
382
383
384
385
386
387
388
389
390

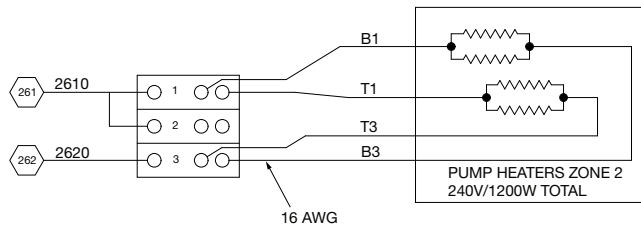
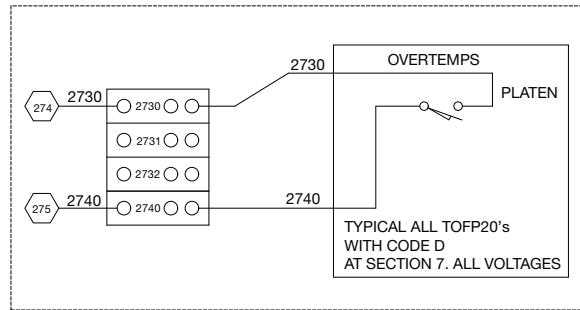
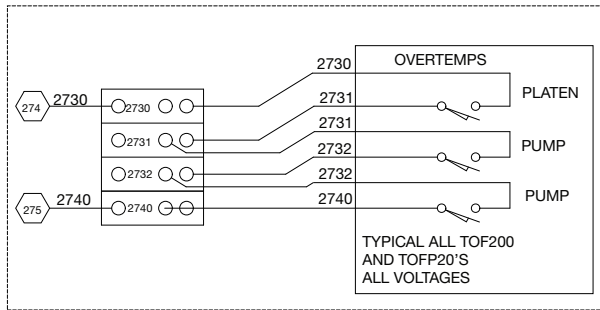

MZLP Zones

400
401
402
403
404
405
406
407
408
409
410
411
412
413
414
415
416
417
418
419
420
421
422
423
424
425
426
427
428
429
430
431
432
433
434
435
436
437
438
439
430

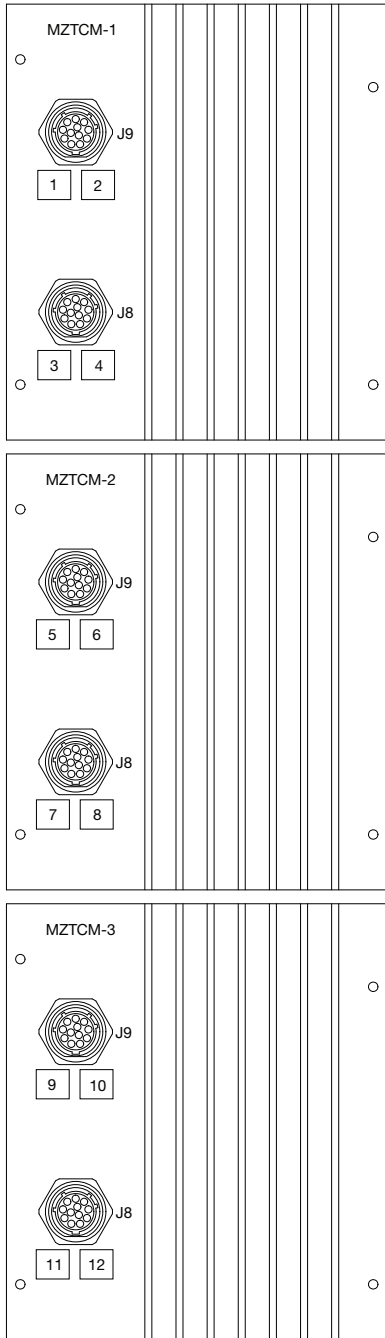

TYPICAL ZONE PIN OUT		
CONNECTOR	PIN #	FUNCTION
MZTCM-1		
MZMTCM-1 J9	A	ZONE 1, L2
	B	SHIELD
	C	ZONE 2, L1
	D	ZONE 2, L2
	E	JUMPER
	F	ZONE 1, START
	G	ZONE 1, RTD
	H	JUMPER
	J	ZONE 1, L1
	K	RTD EXCITE
	L	ZONE 2, START
	M	ZONE 2, RTD
	MZMTCM-1 J8	A
B		SHIELD
C		ZONE 4, L1
D		ZONE 4, L2
E		JUMPER
F		ZONE 3, START
G		ZONE 3, RTD
H		JUMPER
J		ZONE 3, L1
K		RTD EXCITE
L		ZONE 4, START
M		ZONE 4, RTD
MZTCM-2		
MZMTCM-2 J9	A	ZONE 5, L2
	B	SHIELD
	C	ZONE 6, L1
	D	ZONE 6, L2
	E	JUMPER
	F	ZONE 5, START
	G	ZONE 5, RTD
	H	JUMPER
	J	ZONE 5, L1
	K	RTD EXCITE
	L	ZONE 6, START
	M	ZONE 6, RTD
	MZMTCM-2 J8	A
B		SHIELD
C		ZONE 8, L1
D		ZONE 8, L2
E		JUMPER
F		ZONE 7, START
G		ZONE 7, RTD
H		JUMPER
J		ZONE 7, L1
K		RTD EXCITE
L		ZONE 8, START
M		ZONE 8, RTD
MZTCM-3		
MZMTCM-3 J9	A	ZONE 9, L2
	B	SHIELD
	C	ZONE 10, L1
	D	ZONE 10, L2
	E	JUMPER
	F	ZONE 9, START
	G	ZONE 9, RTD
	H	JUMPER
	J	ZONE 9, L1
	K	RTD EXCITE
	L	ZONE 10, START
	M	ZONE 10, RTD
	MZMTCM-3 J8	A
B		SHIELD
C		ZONE 12, L1
D		ZONE 12, L2
E		JUMPER
F		ZONE 11, START
G		ZONE 11, RTD
H		JUMPER
J		ZONE 11, L1
K		RTD EXCITE
L		ZONE 12, START
M		ZONE 12, RTD

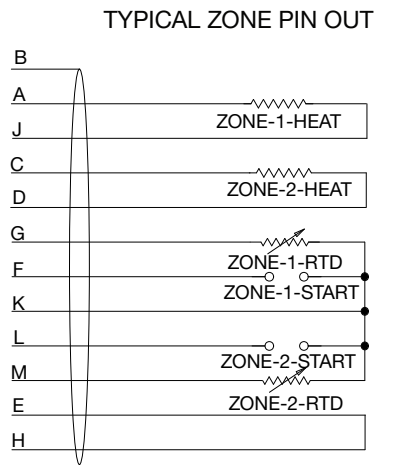
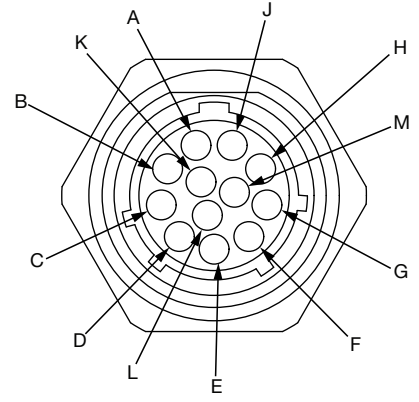

Parts

Part numbers for replacement items on two identical systems with the same model features may differ slightly based on when they were built. When it is necessary to change components during the construction of the Therm-O-Flow® 20 that are not interchangeable with previous models the series letter in the model number will change. For parts affected by this series change, the parts list will have notes indicating which part number applies to which series letter.

The system ID label is located on the control panel and contains the full model number including the series number. See **Models** on page 7 for reference. The service label is located on the upper left corner of the control panel and contains a QR code that will link to the Therm-O-Flow® products page of help.graco.com. This website gives you access to current manuals and additional support materials for the Therm-O-Flow® system as well as other Graco products.

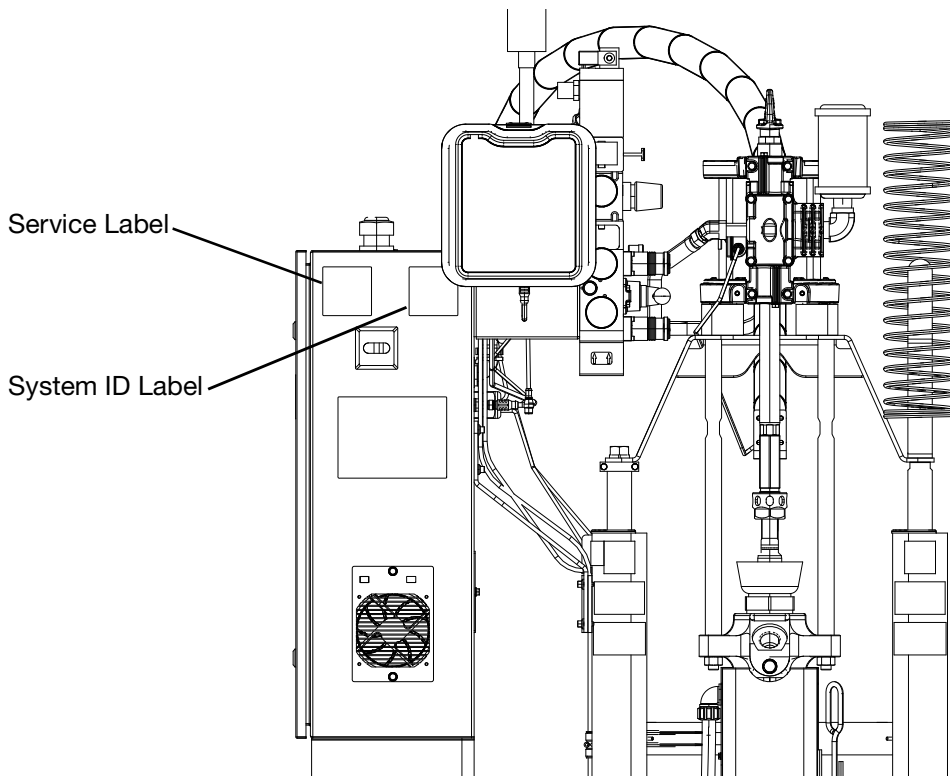
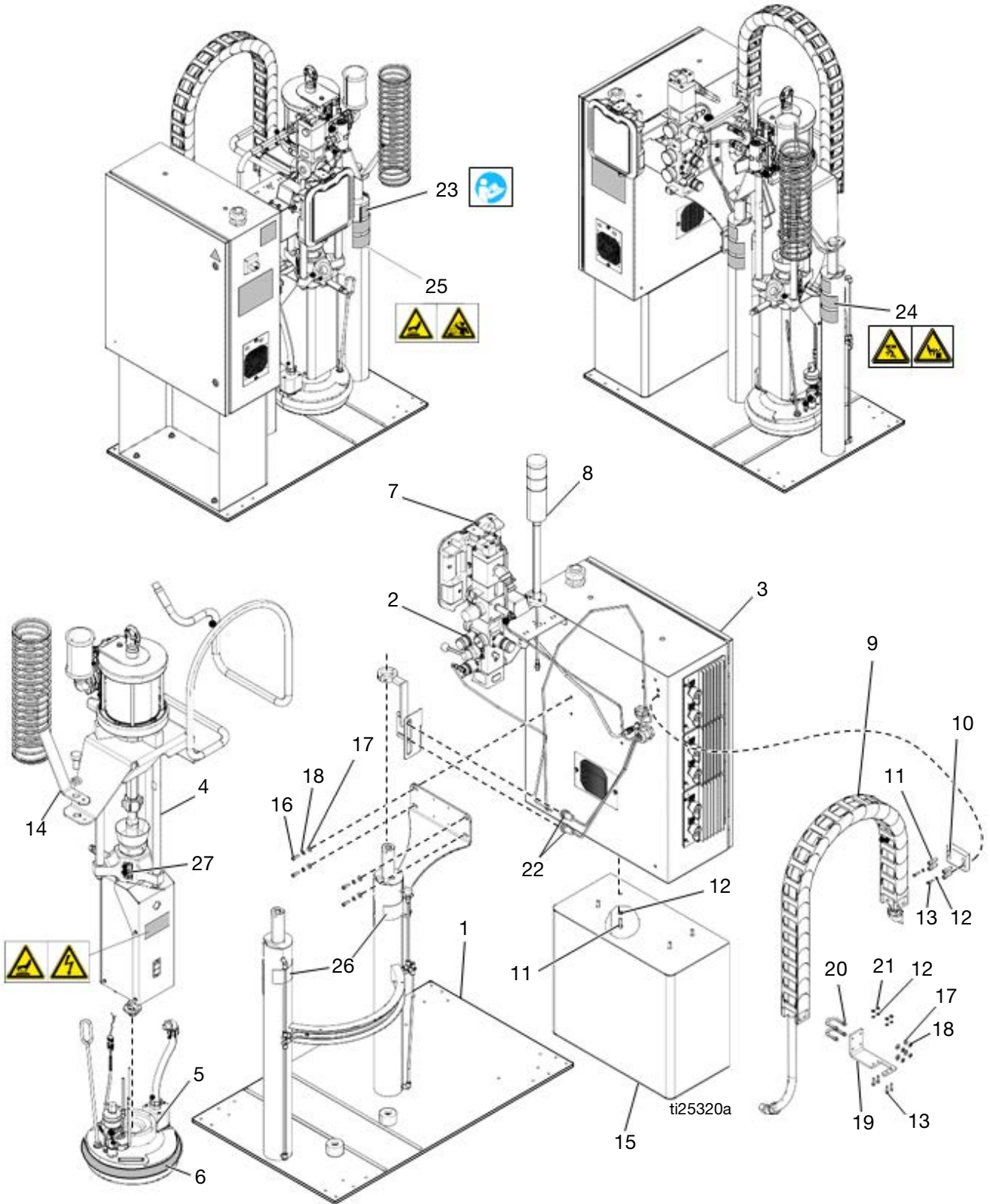

FIG. 36

Therm-O-Flow 20 Supply Unit



Therm-O-Flow 20 Supply Unit

Ref	Part	Description	Qty	Ref	Part	Description	Qty
1	24W181	CART, assembly, TOF 20	1	14	288543	BRACKET, hose, spring	1
2	24W870	KIT, air control; see Air Control Assembly , page 72	1	15	---	BRACKET, enclosure, ram	1
3	---	CONTROL, electrical (not used with air control only systems)	1	16	112166	SCREW, cap, sch	4
4	---	MODULE, pump; see Pump Modules , page 80.	1	17	110755	WASHER, plain	8
5	---	PLATEN; see Heated Platens , page 89	1	18	100016	WASHER, lock	8
6	C31065	SEAL	1	19	---	BRACKET, cable track, NXT	1
7	24W812	ADM	1	20	106285	BOLT, u	2
8	24W589	KIT, light tower (optional); see Accessories and Kits , page 91.	1	21	100179	NUT, hex mscr	4
9	---	CABLE, track	1	22	24V745	SENSOR, level, low/empty	1
10	---	BRACKET, cable track, enclosure	1	23	15J076	LABEL, warning, instructions	2
11	101864	SCREW, cap, sch	4	24	15J074	LABEL, warning; moving objects, pinch	4
12	100020	WASHER, lock	6	25	15H668	LABEL, warning; hot surface, splatter	2
13	111820	SCREW, cap, sch	6	26	15J075	LABEL, warning; hot surface, shock	2
				27	184090	LABEL, warning	1

Air Control Assembly

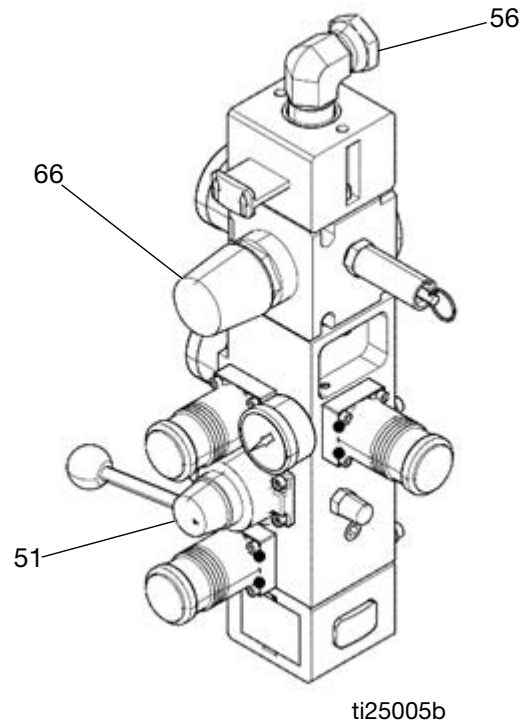
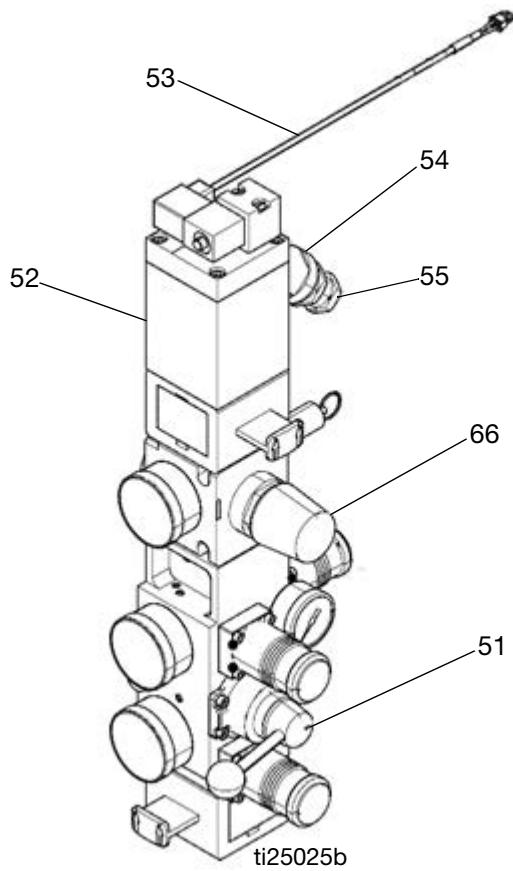

Ref	Part	Description	Qty
51	24W870	KIT, CONTROL, air, 3 regulator; see manual 334201	1
52	121235	SOLENOID, air motor, ram	1

Ref	Part	Description	Qty
53	17A557	HARNESS, solenoid, MZLP	1
54	113445	FITTING, elbow, street	1
55	121282	FITTING, swivel, straight	1
56	120375	ADAPTER, elbow, 3/4-14 nptf x 1/2-14 npsm	1
66	255651	KIT, reg, air motor, ram	1

Replacement Warning Labels, signs, tabs, and cards are available at no cost.

Electrical Module

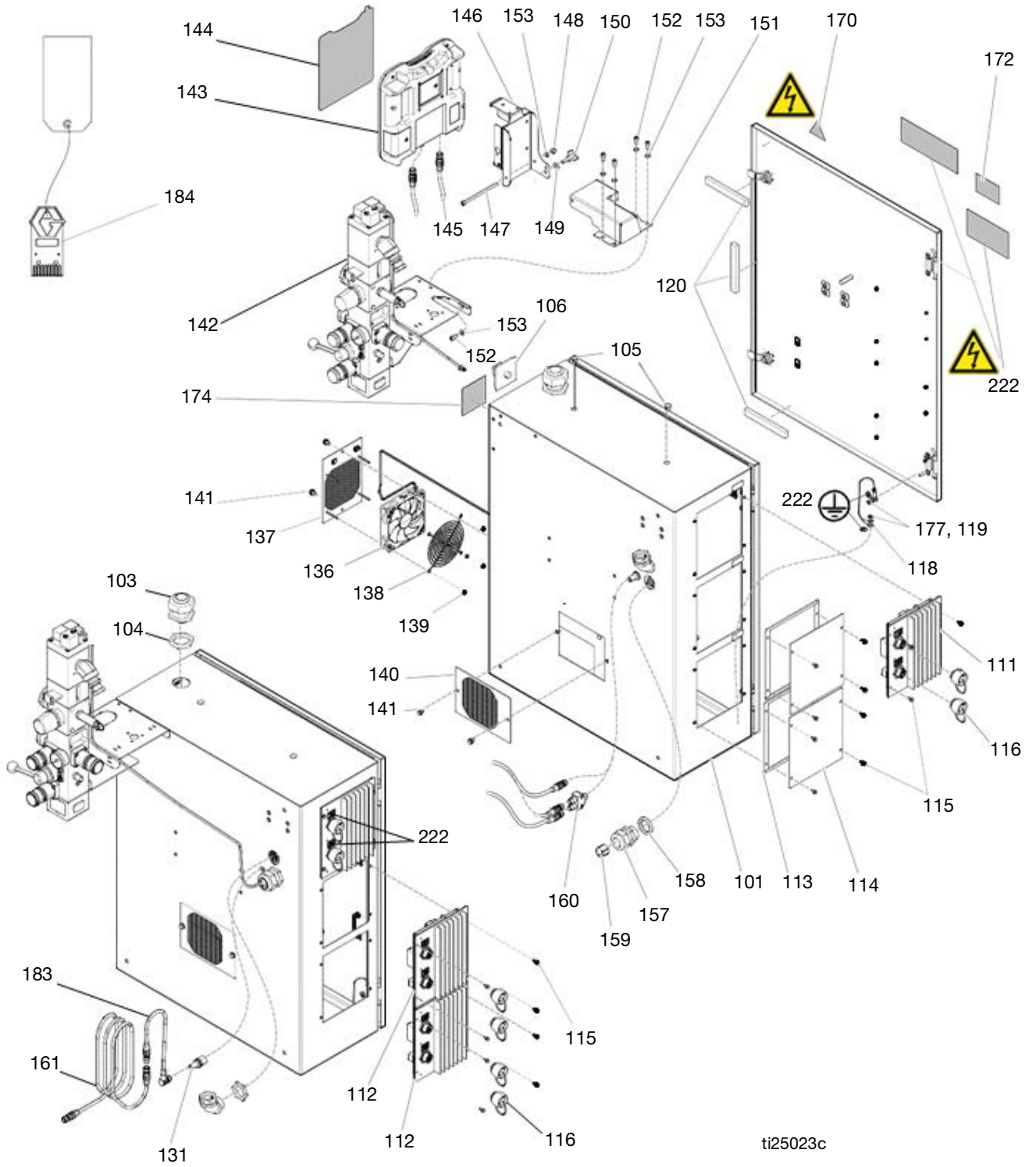

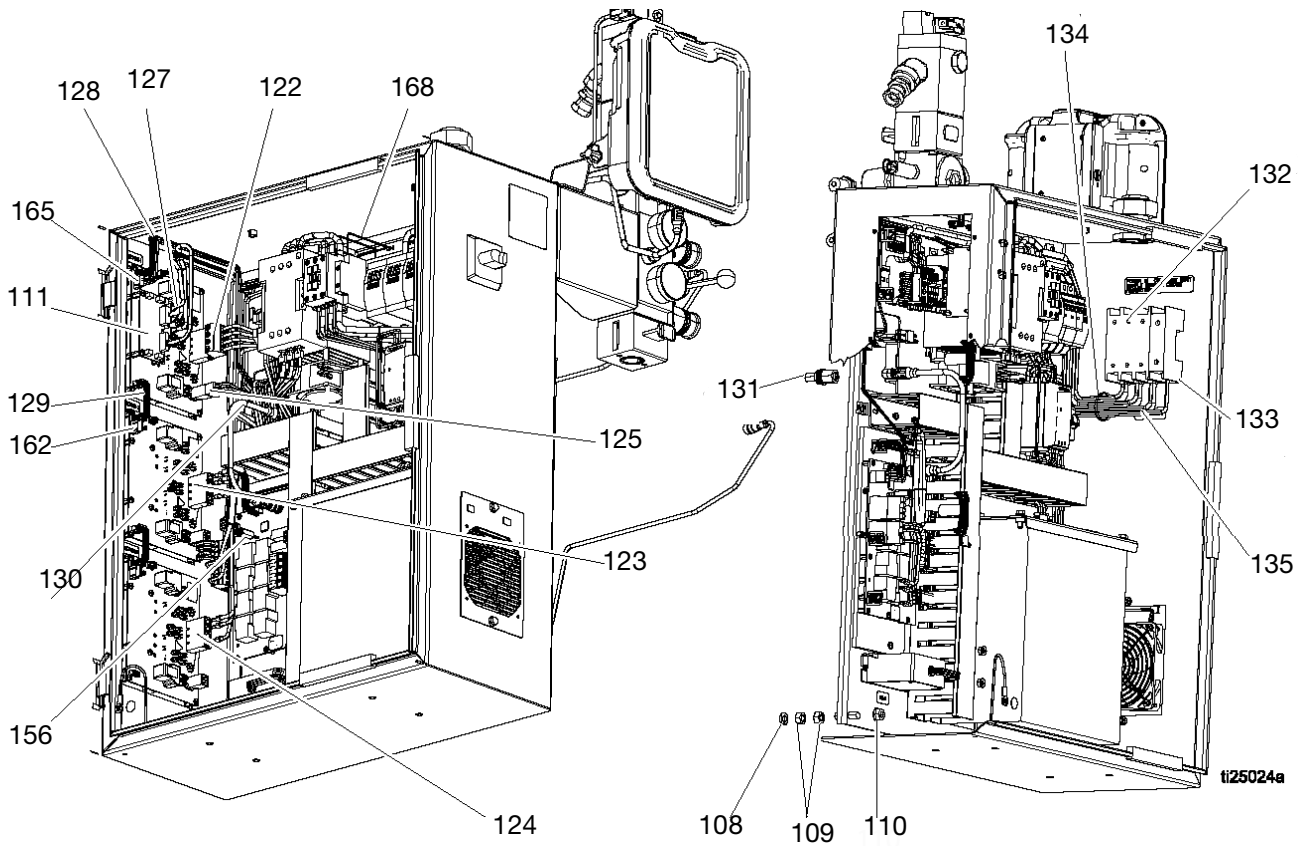
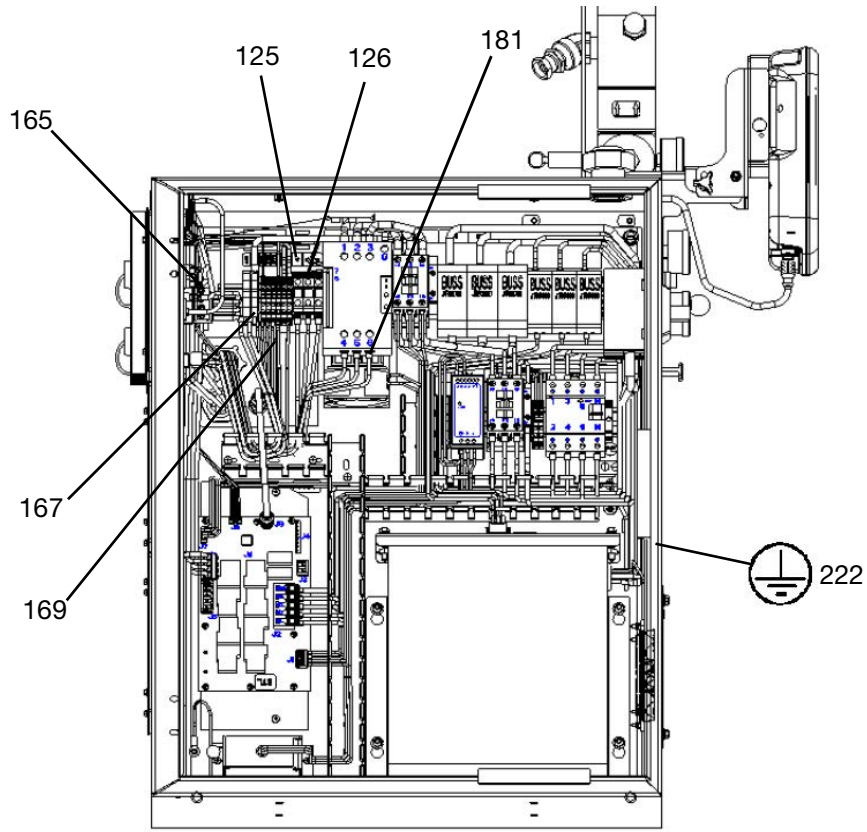

Electrical Control Module Parts

Ref	Part	Description	Qty	Ref	Part	Description	Qty
101	---	ENCLOSURE, electrical	1	125	---	HARNESS, pump, mzl1, tb, tof	1
103	---	BUSHING, strain relief, m40 thread	1	126	---	HARNESS, output, mzl1, ssr, contact	1
104	---	NUT, strain relief, m40 thread	1	127	17A555	HARNESS, pump, reed switch, tof	1
105	125946	PLUG, hole, 1/2 in	2	128	17A559	HARNESS, board, mxm, comm	1
106	123967	KNOB, operator disconnect	1	129	127511	CABLE, board, samtec	
107	---	PANEL, elec, transformer <i>(transformer assemblies only)</i>	1			<i>(8 zone assemblies only; Qty 1) (12 zone assemblies only; Qty 2)</i>	
	---	PANEL, elec, 400v/n <i>(400V modules only)</i>	1	130	121226	CABLE, can, male / female, 0.4m	1
	---	PANEL, elec, 230v/n <i>(230V modules only)</i>	1	131	121612	CONNECTOR, thru, m12, mxm	1
108	100133	WASHER, lock, 3/8	4	132	123969	SWITCH, disconnect, 100a	1
109	100307	NUT, hex	8		123968	SWITCH, disconnect, ph exp 100 A <i>(400V only)</i>	1
110	123396	NUT, flange, serrated, 3/8-16	4	134	---	HARNESS, disc, fuse, 230-600v	1
111*	---	MODULE, gca, mzl1 w/ daughter board	1		17A547	HARNESS, disc, cb, 400v/n, tof <i>(400V only)</i>	1
112	24V510	MODULE, gca, mzl1 <i>(8 zone assemblies only; Qty 1)</i> <i>(12 zone assemblies only; Qty 2)</i>		136	24V911	FAN, 24v dc, 120m x 120m <i>(400V only)</i>	1
112a	24R042	KIT, daughter, board	1	137	16X884	GRILL, fan <i>(400V only)</i>	1
113	---	GASKET, foam <i>(8 zone assemblies only; Qty 1)</i> <i>(12 zone assemblies only; Qty 2)</i>		138	115836	GUARD, finger <i>(400V only)</i>	1
114	24P175	PLATE, blank <i>(4 zone assemblies only; Qty 2)</i> <i>(8 zone assemblies only; Qty 1)</i>		139	127278	NUT, keps, hex <i>(400V only)</i>	4
115	125856	SCREW, 8-32, serrated flange	12	140	24V746	GRILL, vent <i>(230V and 400V assemblies only; Qty 2)</i> <i>(Transformer assemblies only; Qty1)</i>	
116	16T440	CAP, souriau, uts 14 <i>(4 zone assemblies only; Qty 2)</i> <i>(8 zone assemblies only; Qty 4)</i> <i>(12 zone assemblies only; Qty 6)</i>		141	119865	SCREW, mach, hex serrated	4
118	---	WIRE, grounding, door	1	142	---	CONTROL, air, assy; with solenoid	1
119	100166	NUT, full hex	2	143	24W812	ADM <i>(Primary assemblies only)</i>	1
120	---	GASKET, hphm	1	144	15V551	SHIELD, membrane, ADM <i>(Primary assemblies only)</i>	0.1
122	17A543	HARNESS, power, mzl1, awb	1	145	121001	CABLE, can, female / female 1.0m <i>(Primary assemblies only)</i>	1
123	17A544	HARNESS, power, mzl2, awb <i>(8 zone assemblies only)</i>	1	146	---	BRACKET, mounting, assembly <i>(Primary assemblies only)</i>	1
	17A545	HARNESS, power, mzl2/3, awb <i>(12 zone assemblies only)</i>	1	147	121250	SCREW, shcs, 1/4uncx4.25 <i>(Primary assemblies only)</i>	1
				148	102040	NUT, lock, hex <i>(Primary assemblies only)</i>	1
				149	110755	WASHER, plain <i>(Primary assemblies only)</i>	1

Parts

Ref	Part	Description	Qty	Ref	Part	Description	Qty
150	121253	KNOB, display adj., ram pkgs <i>(Primary assemblies only)</i>	1	165	---	HARNESS, input, mzl1p1, RTD	1
151	---	BRACKET, pendant pivot, <i>(Primary assemblies only)</i>	1	166	127771	BRIDGE, plug-in, 2pos, ut16 <i>(400V and Transformer modules only)</i>	1
152	101550	SCREW, cap, sch <i>(Primary assemblies only)</i>	4	167	---	FERRULE, wire, 10awg <i>(230V modules only; Qty 2) (400V and transformer modules only; Qty 8)</i>	
153	100016	WASHER, lock <i>(Primary assemblies only)</i>	5	168	---	FERRULE, wire, 16awg	6
156	24V745	SENSOR, level, low/empty	1	169	---	FERRULE, wire, 18 awg, long	6
157	---	BUSHING, strain relief	1	170	196548	LABEL, warning, shock	1
158	---	NUT, bushing	1	172	---	ARTWORK, instructions, wiring, ul	1
159	---	GROMMET, wire	1	181	---	FERRULE, wire, 10awg, twin <i>(Secondary assemblies only)</i>	3
160	124654	CONNECTOR, splitter, 12(m) x m12(f) <i>(Secondary modules only)</i>	1	182	17C669	CONNECTOR, jumper, male <i>(Secondary assemblies only)</i>	1
161	121228	CABLE, can, female/female, 15.0 m <i>(Secondary modules only)</i>	1	183	123856	HARNESS, CAN, cable <i>(Secondary assemblies only)</i>	1
162	16W035	CONNECTOR, jumper <i>(8 zone assemblies only;</i> <i>Qty 1) (12 zone assemblies only;</i> <i>Qty 2)</i>		184	17C712	TOKEN <i>(Secondary assemblies only)</i>	1
163	---	CONTACT, socket, 20-24 awg, crimp, tin	3	<i>Replacement Warning labels, signs, tags, and cards are available at no cost.</i>			
164	---	TUBE, 1/16 shrink tube	0.1 3	<i>* Ref. No. (111) consists of two parts that must be ordered separately: part No. 24V510 (112) and part No. 24R042 (112A).</i>			

Electrical Panel

230V

400V

Transformer

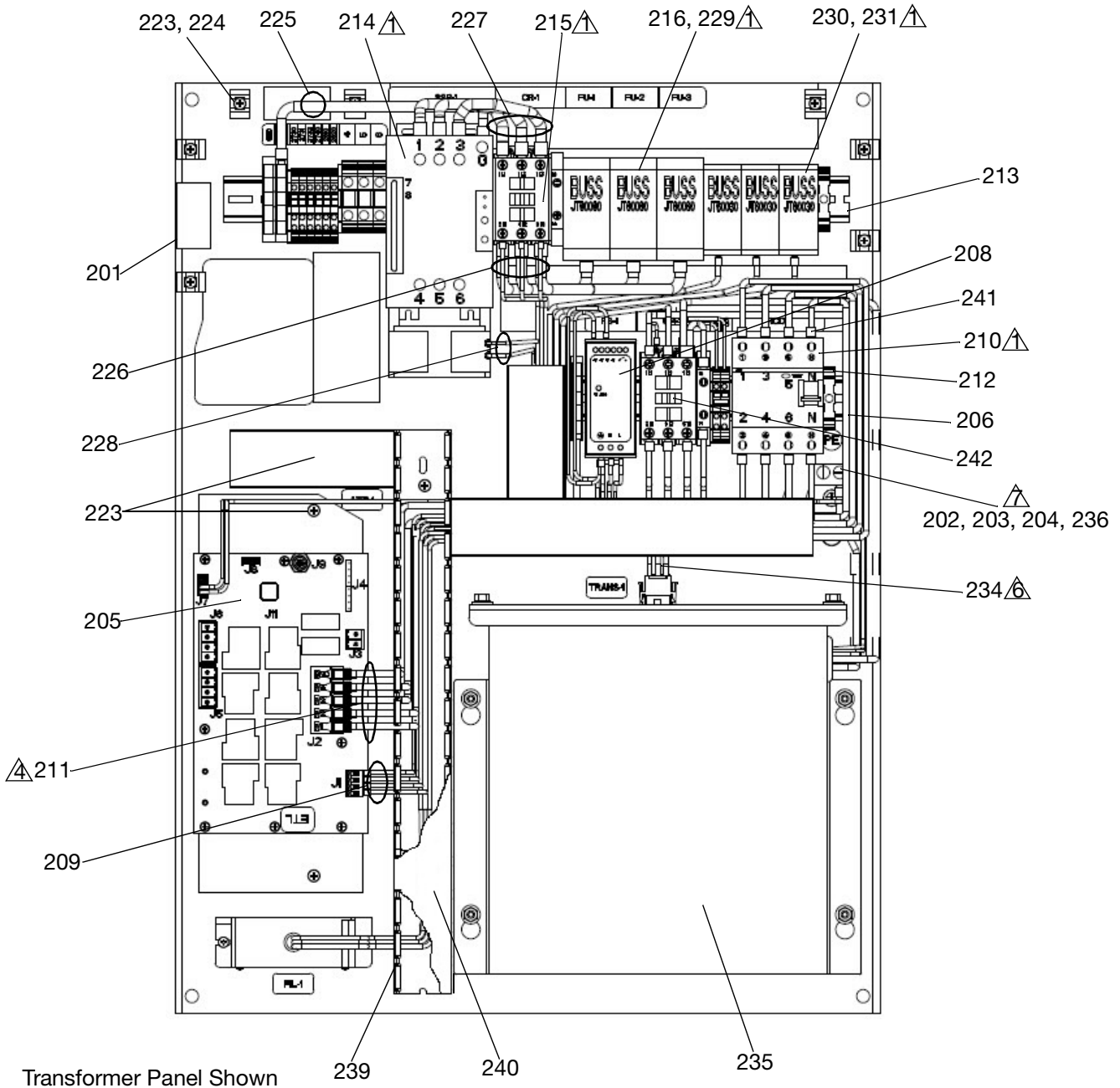

- △ Torque terminals to 25-27 in-lbs (2.8-3.1 N•m).
- △ Torque terminals to 13.3-16 in-lbs (1.5-1.8 N•m)
- △ Torque terminals to 4.53-6.2 in-lbs (0.5-0.7 N•m)

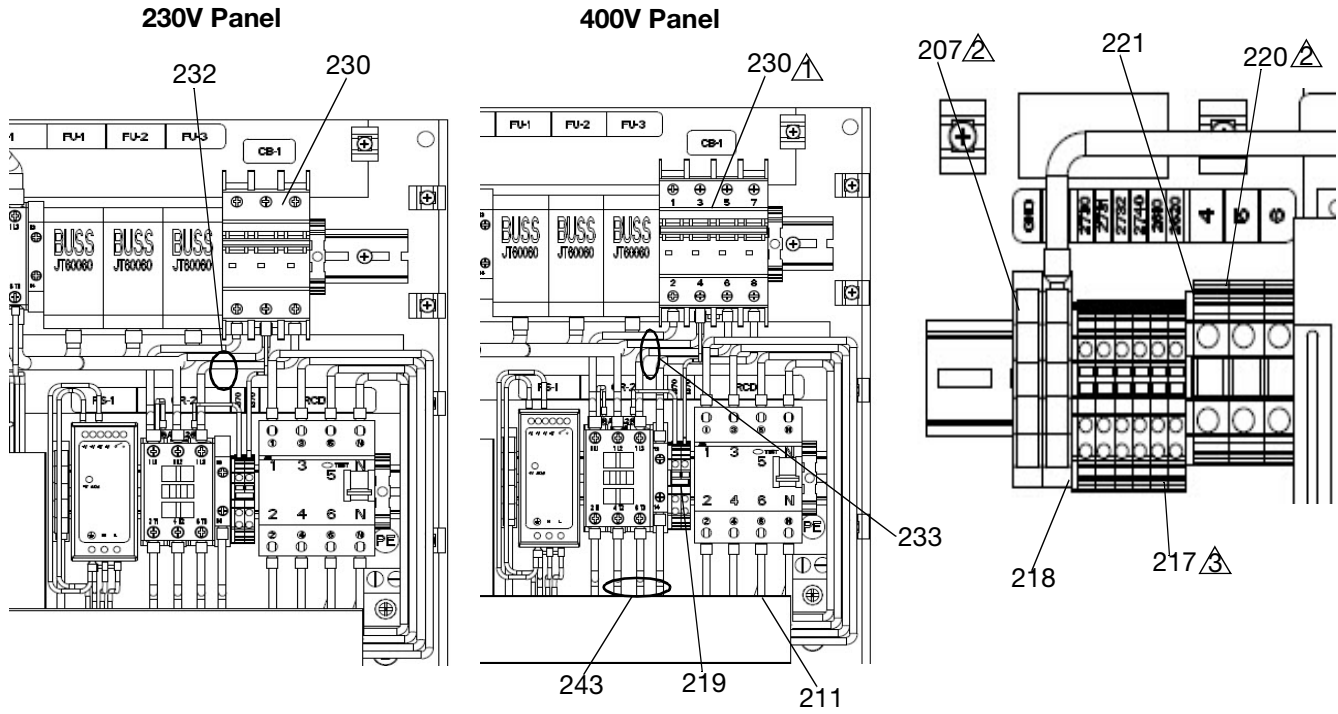

- ▲ Torque terminals to 25-27 in-lbs (2.8-3.1 N•m).
- ▲ Torque terminals to 13.3-16 in-lbs (1.5-1.8 N•m)
- ▲ Torque terminals to 4.53-6.2 in-lbs (0.5-0.7 N•m)

Electrical Panel Parts

Ref	Part	Description	Qty	Ref	Part	Description	Qty
201	---	PANEL, elec, tof, 11ga, zinc	1	230◆✓	127744	CIRCUIT, breaker, 3p, 32a, ul489; 230V Panel only	1
202	117666	TERMINAL, ground	1	230◆✓	127745	CIRCUIT, breaker, 20a, 4p, ul489; 400V Panel only	1
203	113783	SCREW, machine, pn hd	1	231	---	See Code C Table	3
204	100985	WASHER, lock ext	1	232	17L788	HARNESS, cb, rcd, 230-400V; 230V and 400V Panel only	1
205	24V816	MODULE, gca, awb	1	233	17L789	HARNESS, cb, rcd, 400v/n; 400V Panel only	1
206	---	RAIL, din, 6.5in	1	234	17A541	HARNESS, fuses, transformer; Transformer panel only	1
207	123363	BLOCK, terminal, ground, 10mm	3	235	24V718	TRANSFORMER, multi-tap/230v, 6kva; Transformer panel only	1
208	126453	POWER SUPPLY, 24v	1	237	128014	FILTER, voltage, transient, 600V, 3P	1
209	---	HARNESS, power supply, awb	1	238	112380	SCREW, mach, pn hd	2
210	128097	CIRCUIT, breaker, 63a, 4p, rcd	1	239	81/0163	WIREWAY, panduit -B/11	4
211	---	HARNESS, rcd, awb	1	240	81/0164	COVER, panduit -B/11	4
212	126811	BLOCK, clamp end	2	241	17L790	HARNESS	1
213	---	RAIL, din, 19in	1	242*	129120	CONTACTOR 240V	1
214	120399	CONTROL, 65 amp, 120-600v	1	243	17L787	HARNESS	1
215	123359	RELAY, contactor, 30a, 3p, 24vdc co	1	▲Replacement Warning labels, signs, tags, and cards are available at no cost.			
216◆	6690-24-165	FUSE, fuse block buss jt60060	3				
216✓	134004	FUSE, block, 60A, type cc, 3P	1	◆ Applies to Series A , B and C			
217	128314	BLOCK, terminal 3-wire	8				
218	128321	COVER, end	2	✓ Applies to series D			
219	126819	BRIDGE, plug-in, 2-position	1				
220	127717	BLOCK, terminal, 2pos, ut16	3	* Ref. No. (242) CR-2 device is included on series A through E systems. This component is not included non series F systems. See notes on Electrical Schematics page 61.			
221	127718	COVER, end, ut16	1				
222▲	17C137	LABEL, multi safety	1				
223	103833	SCREW, mach, crbh	33				
224	123452	HOLDER, anchor, wire tie, nylon	12				
225	---	HARNESS, wire, ground, 8awg	1				
226	---	HARNESS, fuse, contactor	1				
227	---	HARNESS, contactor, SSR	1				
228	---	HARNESS, rcd, SSR fan	1				
229	---	See Code C Table	3				
230◆	6690-24-164	FUSE, fuse block buss jt60030	3				
230✓	134005	FUSE, block, 30A, type cc, 3P	1				

If Code A is 20P and Code E is F/S and Code C is		
Code C	(229)	(231)
X1X	24X879	NA
X2X	24X873	NA
X3X	24X873	24X878◆, 26D828✓
X4X	24X875	24X877◆, 26D827✓
X5X	24X876	24X874◆, 26D826✓

Merkur 2200, 23:1 Pump Modules

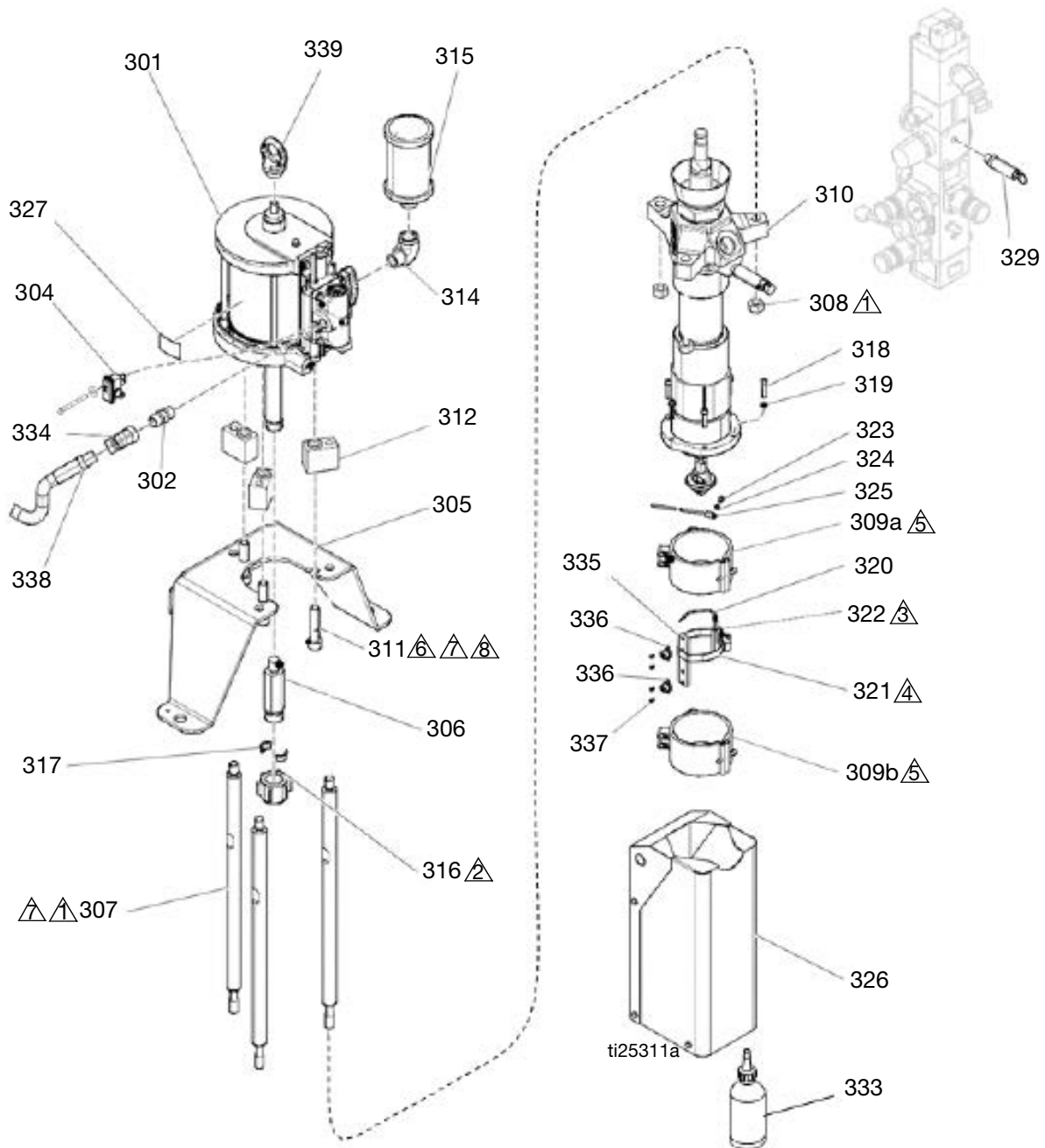

- Torque to 50-60 ft-lbs (68-81 N•m).
- Torque to 145-155 ft-lbs (196-210 N•m).
- Coat mounting surface of sensor mounting block with non-silicone heat sink compound. Do not coat sensor.
- Prior to tightening band clamp (321), RTD sensor (320) must be fully contained within the sensor mount (322).

- Coat inside of heater (309a, 309b) only to within 3/4 in. of vertical ends with non-silicone heat sink compound before mounting.
- Cap screws (311) must be loose while tie rods (307) are being torqued.
- Torque to 150 ft-lb (203 N•m).
- Apply anaerobic sealant.

Merkur 2200, 23:1 Pump Modules

Ref	Part	Description	Qty
301	24W754	MOTOR, air, 6 in, 4.75 stroke, blue	1
302	C20485	FITTING, hex, nipple	1
304	24R885	SWITCH, reed assy	1
305	---	BRACKET, motor mount	1
306	15H397	ADAPTER, rod, pump	1
307	16A223	ROD, tie, vert driver	3
308	106166	NUT, mach ,hex	3
309	---	HEATER, pump, 600 watt	2
310	24W152	PUMP, tof200, cf; 24V572 only	1
	24W153	PUMP, tof200, gf; 24V575 only	1
311	109211	SCREW, cap, sch	3
312	17A637	BLOCK, standoff, mounting	3
315	102656	MUFFLER	1
316	186925	NUT, coupling	1
317	184129	COLLAR, coupling	2
318	103345	SCREW, cap, sch	2
319	100016	WASHER, lock	4
320	24Z093	SENSOR, RTD	1
321	C31012	CLAMP	1
322	C03507	SUPPORT, sensor	1
323	C38162	SCREW, machine	1
324	C38163	WASHER, lock, ext. tooth	1
325	---	CONDUCTOR, ground	1
326	---	SHIELD, pump, tof20	1
329	120306	VALVE, safety, 85 psi	1
330	C33049	TAPE, adhesive, fiberglass	1.5
331	---	LUBRICANT, high temp, thermal	1
333	206994	FLUID, tsl 8 oz bottle	1
334	127766	FITTING, 45 elbow swivel, 1/2 npt(f) x 1/2 nps	1
365	127671	SWITCH, over temp, fixed, 450°F (232°C)	2
335	17B715	SUPPORT, block, over temp	1
336	127671	SWITCH, over temp, fixed, 450°F (232°C)	2
337	122338	SCREW, cap, socket bh	4
338	214656	HOSE, coupled	1
339	16C009	HOOK	1

Merkur 3400, 36:1 Pump Modules

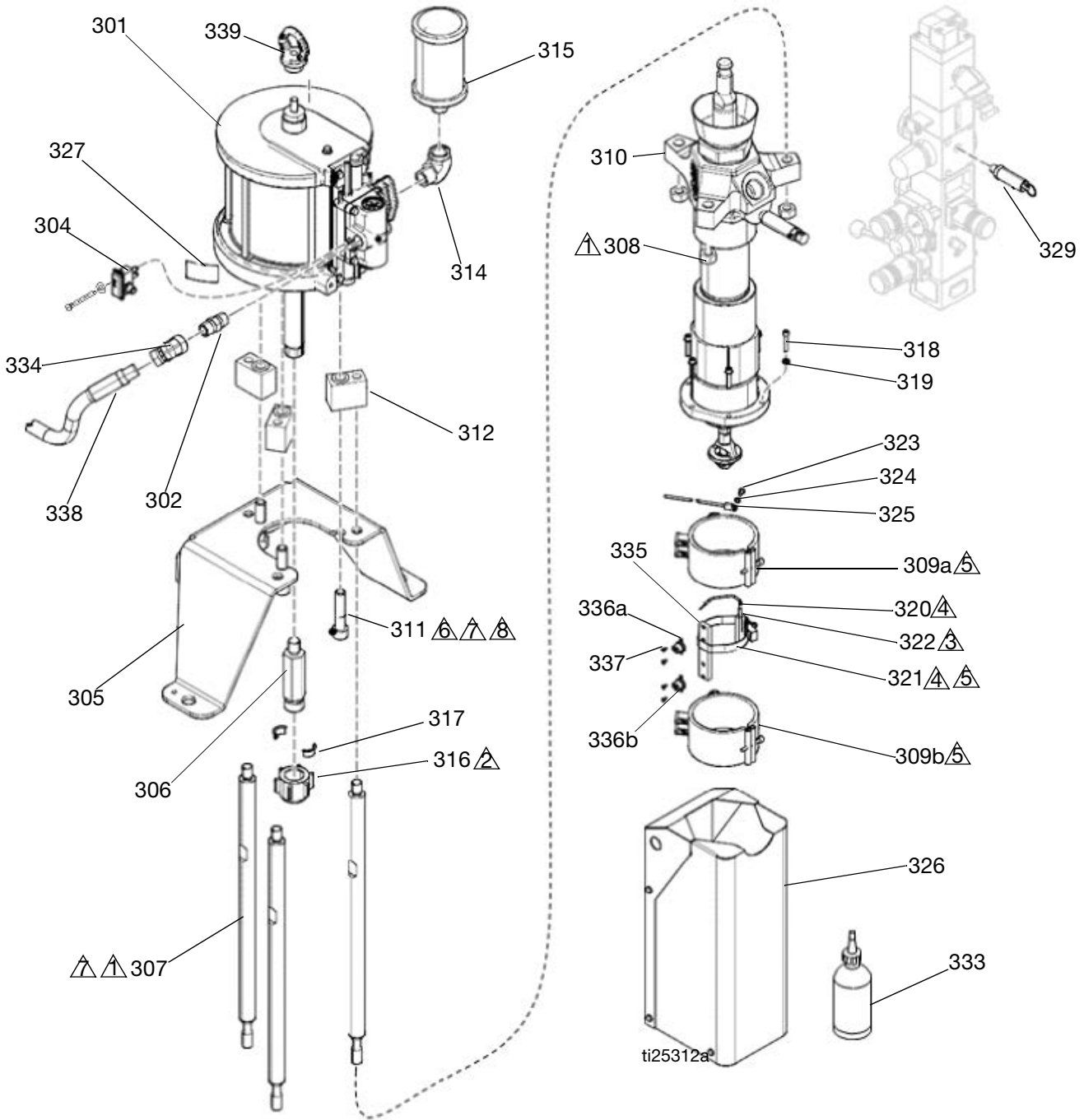

Torque to 50-60 ft-lbs (68-81 N•m).

Torque to 145-155 ft-lbs (196-210 N•m).

Coat mounting surface of sensor mounting block with non-silicone heat sink compound. Do not coat sensor.

Prior to tightening band clamp (321), RTD sensor (320) must be fully contained within the sensor mount (322).

Coat inside of heater (309a, 309b) only to within 3/4 in. of vertical ends with non-silicone heat sink compound before mounting.

Cap screws (311) must be loose while tie rods (307) are being torqued.

Torque to 150 ft-lbs (203 N•m).

Apply anaerobic sealant.

Merkur 3400, 36:1 Pump Modules

Ref	Part	Description	Qty	Ref	Part	Description	Qty
301	24R015	MOTOR, assy, air, 7.5 in, blue	1	335	17B715	SUPPORT, block, over temp	1
302	C20485	FITTING, nipple, hex	1	336	127671	SWITCH, over temp, fixed, 450°F (232°C)	2
304	24R885	SWITCH, reed assy	1	337	122338	SCREW, cap, socket bh	4
305	---	BRACKET, motor mount, tof 200	1	338	214656	HOSE, coupled	1
306	15H397	ADAPTER, rod, pump	1	339	16C009	HOOK	1
307	16A223	ROD, tie, vert driver	3				
308	106166	NUT, mach, hex	3				
309	---	HEATER, pump, 600 watt	2				
310	24W152	PUMP, tof20, long shaft, cf; 24V573 only	1				
	24W153	PUMP, tof20, long shaft, gf; 24V576 only	1				
311	109211	SCREW, cap, sch	3				
312	17A637	BLOCK, standoff, mounting	3				
315	102656	MUFFLER	1				
316	186925	NUT, coupling	1				
317	184129	COLLAR, coupling	2				
318	103345	SCREW, cap, sch	6				
319	100016	WASHER, lock	6				
320	24Z093	SENSOR, RTD	1				
321	C31012	CLAMP	1				
322	C03507	SUPPORT, sensor	1				
323	C38162	SCREW, machine	1				
324	C38163	WASHER, lock, ext. tooth	1				
325	---	CONDUCTOR, ground	1				
326	---	SHIELD, pump	1				
327	---	LABEL, identification	1				
329	120306	VALVE, safety, 85 psi	1				
330	C33049	TAPE, adhesive, fiberglass; 1.5 ft (x m)	1				
331	---	LUBRICANT, high temp, thermal	1				
333	206994	FLUID, tsl 8 oz bottle	1				
334	127766	FITTING, 45 elbow, swivel, 1/2 npt(f) x 1/2 nps	1				

NXT 6500, 70:1 Pump Modules

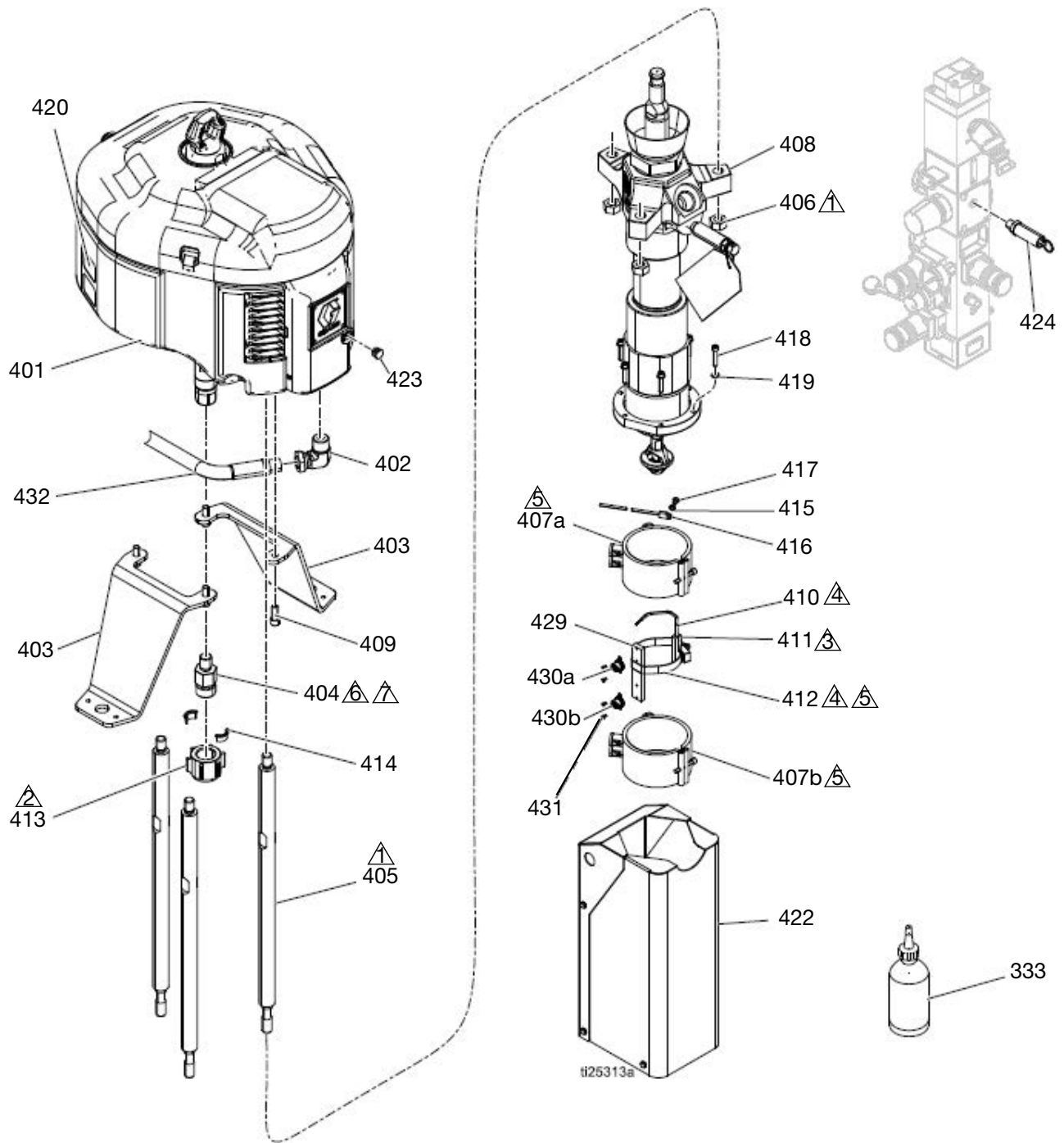

- Torque to 50-60 ft-lbs (68-81 N•m).
- Torque to 145-155 ft-lbs (196-210 N•m).
- Coat mounting surface of sensor mounting block with non-silicone heat sink compound. Do not coat sensor.
- Prior to tightening band clamp (412), RTD sensor (410) must be fully contained within the sensor mount (411).

- Coat inside of heater (407a, 407b) only to within 3/4 in. of vertical ends with non-silicone heat sink compound before mounting.
- Torque to 150 ft-lbs (203 N•m).
- Apply anaerobic sealant.

NXT 6500, 70:1 Pump Modules

Ref	Part	Description	Qty
401	N65LR0	MOTOR, 6500, low-noise, remote	1
402	120375	ADAPTER, elbow, 3/4 NPTI x 1/2 NPTE	1
403	15J288	BRACKET, mounting, motor, tof20	2
404	17A406	ADAPTER, rod, pump, tof	1
405	16A223	ROD, tie, vert driver	3
406	106166	NUT, mach, hex	3
407	128322	HEATER, pump, 600 watt	2
408	24W152	PUMP, tof20, cf; 24V574 only	1
	24W153	PUMP, tof20, gf; 24V577 only	1
409	C19837	SCREW, cap, socket hd	4
410	24Z093	SENSOR, RTD	1
411	C03507	SUPPORT, sensor	1
412	C31012	CLAMP	1
413	186925	NUT, coupling	1
414	184129	COLLAR, coupling	2
415	C38163	WASHER, lock, ext. tooth	1
416	---	CONDUCTOR, ground	1
417	C38162	SCREW, machine	1
418	103345	SCREW, cap, sch	6
419	100016	WASHER, lock	6
420	---	LABEL, ID	1
422	---	SHIELD, pump, tof20	1
423	120588	PLUG, pipe, round	1
424	120012	VALVE, safety, 50 psi	1
425	---	LUBRICANT, high temp, thermal	1
426	C33049	TAPE, adhesive, fiberglass	1.5
428	206994	FLUID, tsl 8 oz bottle	1
429	17B715	SUPPORT, block, over temp	1
430	127671	SWITCH, over temp, fixed, 450	2
431	122338	SCREW, cap, socket bh	4
432	214656	HOSE, coupled	1

Pump Shield

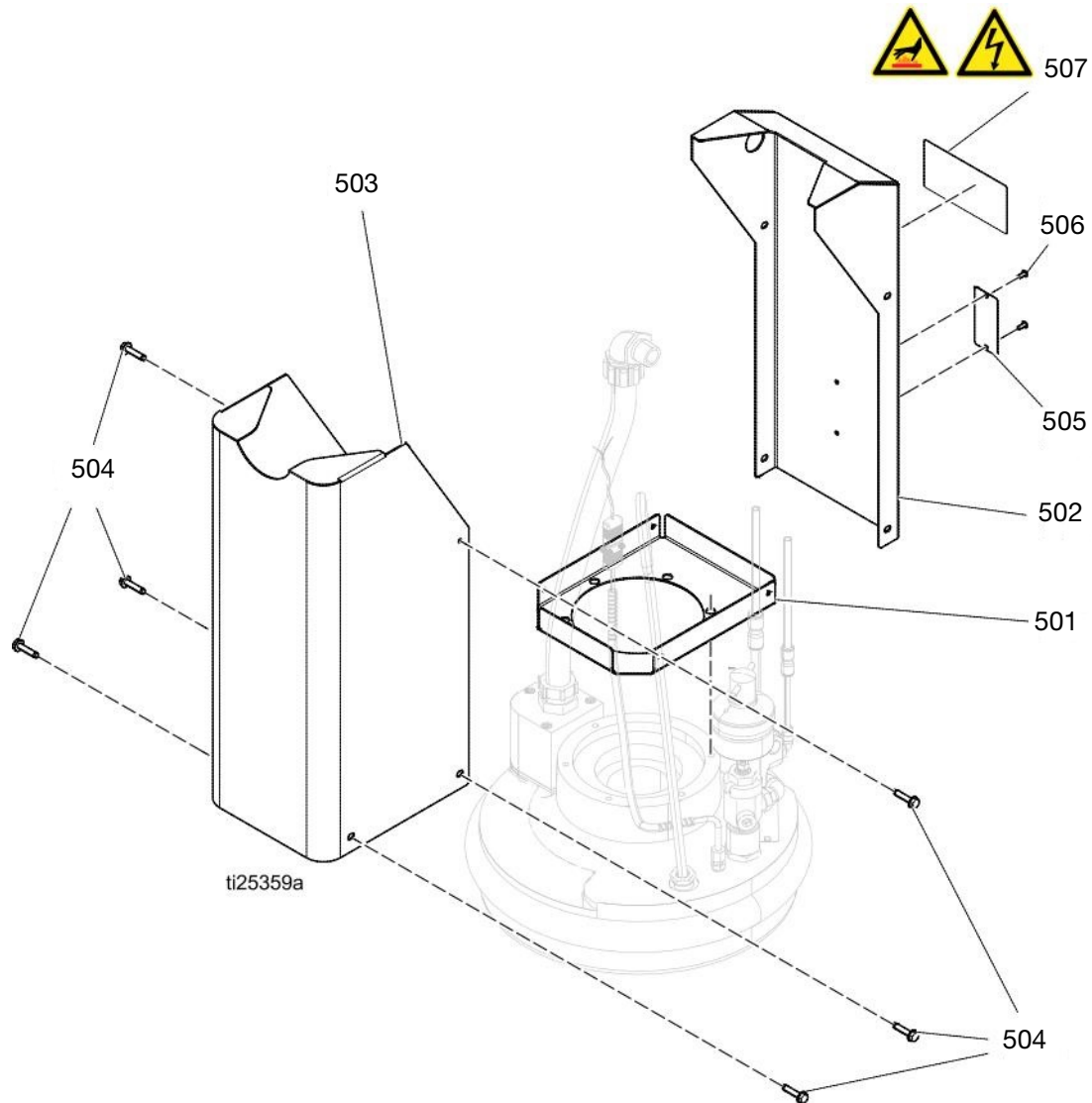

Ref	Part	Description	Qty
501	---	COVER, pump, bottom	1
502	---	COVER, pump, back	1
503	---	COVER, pump, front	1
504	C20474	SCREW, self-tapping	6
505	17J504	LABEL, warning	1
506	104088	RIVET, blind	2
507	15J075	LABEL, safety, hot surface and shock	1

Replacement Warning labels, signs, tags, and cards are available at no cost.

President, 15:1 Pump Module

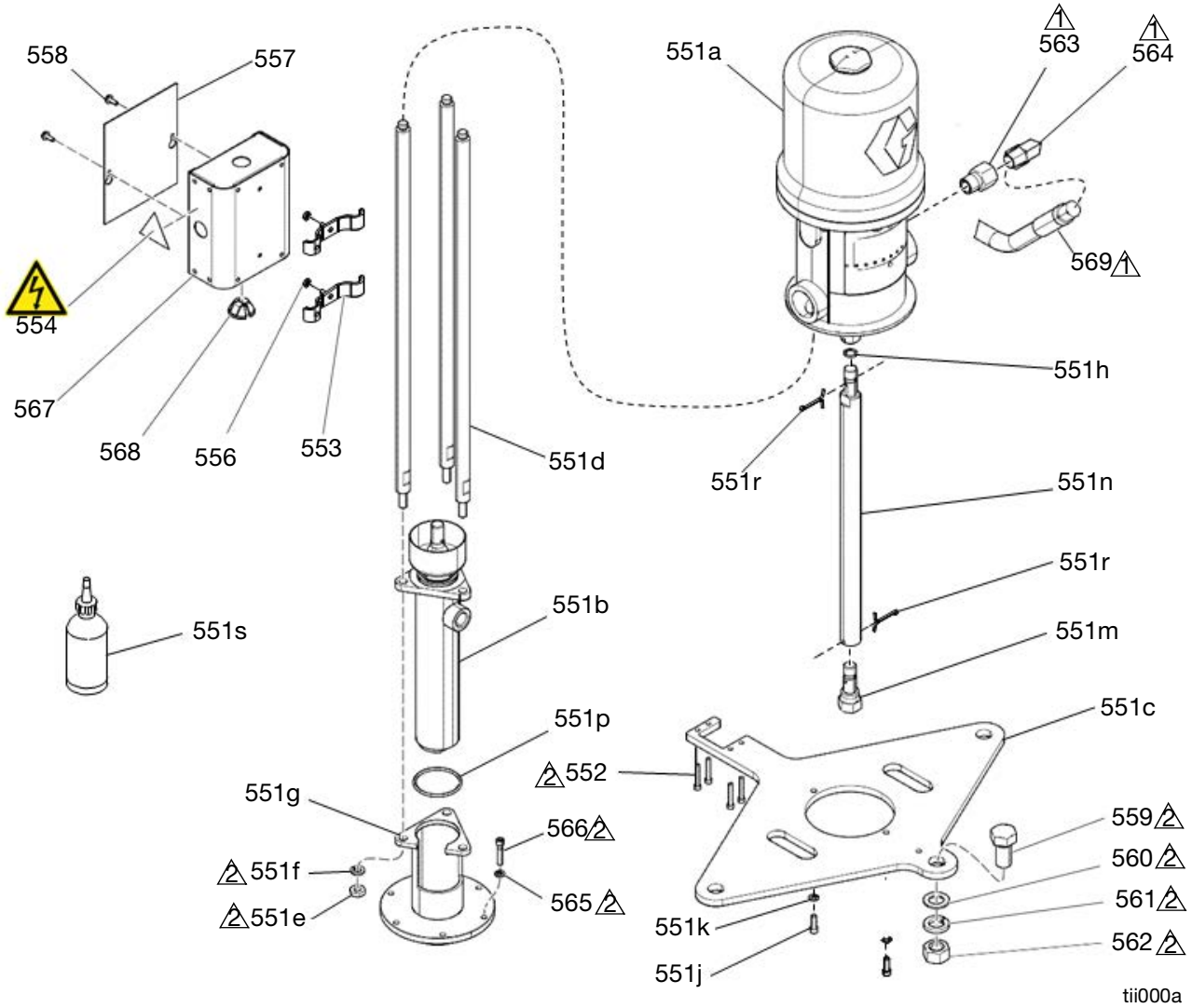

Parts

Ref	Part	Description	Qty
551	288505	PUMP, president	1
551a	24B229	MOTOR, AIR, president	1
551b	918417	PUMP, hot melt mini-5	1
551c	---	PLATE, president mounting	1
551d	198369	ROD, standoff	3
551e	100340	NUT	3
551f	100133	WASHER, lock, 3/8	3
551g	298073	ADAPTER, pump	1
551h	156082	PACKING, o-ring, 112	2
551j	112166	SCREW, cap, sch	2
551k	100016	WASHER, lock	2
551m	207370	ROD, connecting	1
551n	198412	ROD, connecting	1
551p	C38225	PACKING, o-ring	1
551r	101946	PIN, cotter, sst	2
551s	206994	FLUID, TSL, 8 oz	1
552	112756	SCREW, cap, socket hd	4
553	---	BRACKET, mounting, junction box	2
554	196548	LABEL, warning, shock	1
555	100020	WASHER, lock	2
556	100179	NUT, hex mscr	2
557	---	JUNCTION BOX, front cover	1
558	---	FASTENER, thread-cutting screw	2
559	516587	BOLT, 3/4-10 x 1.5 hex head	1
560	154628	WASHER	2
561	101015	WASHER, lock	1
562	C19187	NUT, hex	1
563	---	ADAPTER	1
564	155470	FITTING, swivel, union, 90 degree	1
565	100016	WASHER, lock	6
566	103345	SCREW, cap sch	6
567	---	JUNCTION BOX, main body	1
568	127732	FITTING, 3/4" knockout, romex, pushin	1
569	214656	HOSE, coupled, 61209, 10 ft	1

Replacement Warning labels, signs, tags, and cards are available at no cost.

Heated Platens

24V742, Heated Drum Platen, Standard Finned Bottom (Code E-option F)

24V743, Heated Drum Platen, Smooth Bottom (Code E-option S)

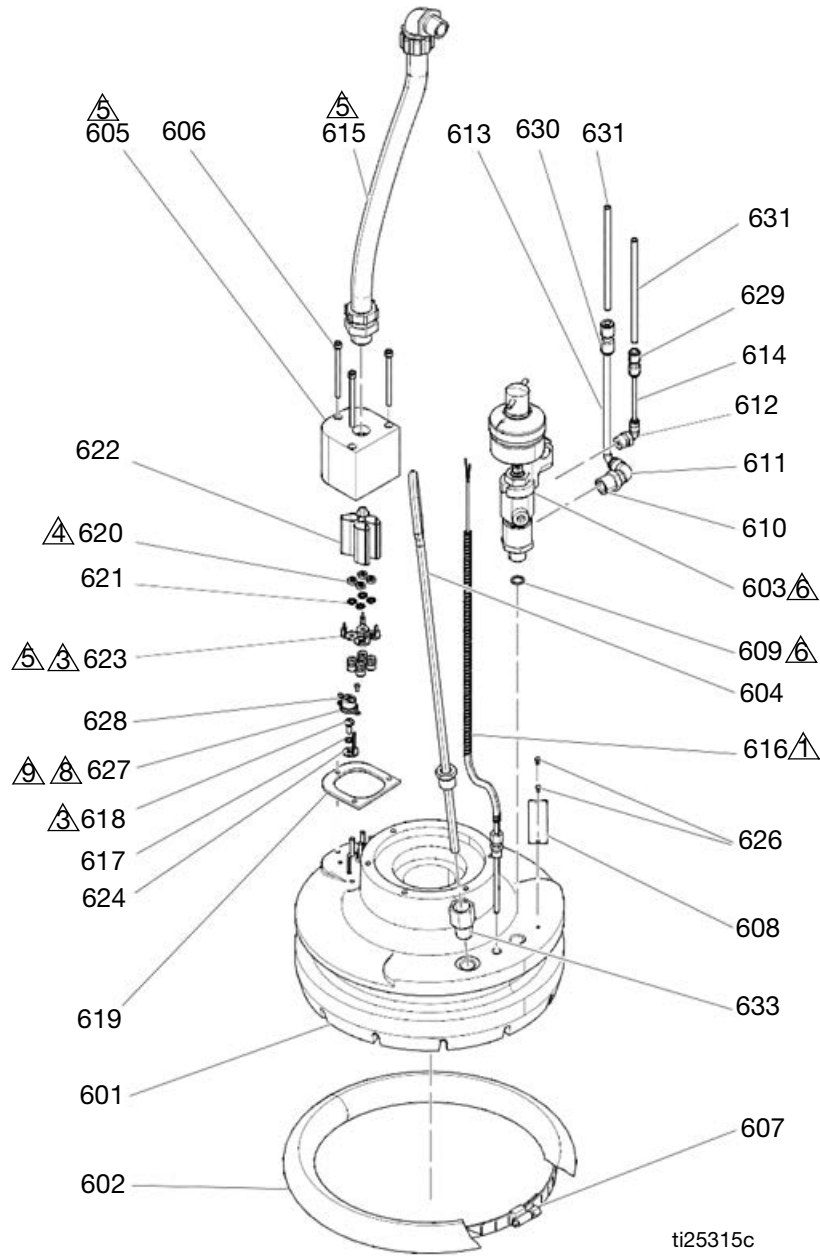

ti25315c

- ⚠ Coat RTD sensor (616) with non-silicone heat sink compound. Coat from tip to 1 in from tip.
- ⚠ Label cables for identification. See Cable Identification.
- ⚠ Do not tighten heater terminal nuts down onto ceramic insulators to prevent damage.

- ⚠ Coat bottom of overtemperature switch (627) with non-silicone heat sink compound.
- ⚠ Label the wires on overtemperature switch (627) 2732, 2740 at the opposite end of the sensor.

24V742, Heated Drum Platen, Standard Finned Bottom (Code E-option F) Parts
24V743, Heated Drum Platen, Smooth Bottom (Code E-option S) Parts

Ref	Part	Description	Qty	Ref	Part	Description	Qty
601	---	PLATEN, standard finned, for 24V742	1	629	127689	FITTING, adapter, 1/4 in x 5/32 in tube	1
601	---	PLATEN, smooth bottom, for 24V743		630	127690	FITTING, adapter, 5/16 in tube x 1/4 in tube	1
602*	---	HOSE, seal, Mini - 5	1	631	054130	HOSE, tubing; 1/4 in OD; 17 ft (5 m)	1
603	207440	VALVE, dispenser	1	632	---	LUBRICANT, high temperature, thermal	1
604	24X439	HANDLE, bleed	1	633	150286	ADAPTER	1
605	---	ADAPTER, bushing	1				
606	514930	SCREW, cap, skt hd	3				
607*	C31154	CLAMP, worm gear	2				
608	---	PLATE, designation	1				
609	167730	GASKET, copper	1				
610	100176	BUSHING, hex	1				
611	115948	ELBOW, 1/4 npt(m), 5/16 OD tube	1				
612	115949	ELBOW, 1/4 npt(m), 5/32 OD tube	1				
613	---	TUBE, PTFE, 1/4 x 5/16; 14 ft (4.2 m)	1				
614	---	TUBE, PTFE, 3/32 x 5/32; 14 ft (4.2 m)	1				
615	---	CONDUIT, hi-temp, w/ fittings	1				
616	24Z094	SENSOR, RTD, 5", 100 ohms, with heat shrink	1				
617	C38163	WASHER, lock, ext. tooth	1				
618	C19049	SCREW, mach, slotted, md hd	1				
619	15C171	GASKET	1				
620	102931	NUT, mach. hex	4				
621	---	WASHER, lock, internal tooth	4				
623	---	CONDUCTOR, heater	4				
624	---	CONDUCTOR, ground	1				
626	100508	SCREW, drive	2				
627	127671	SWITCH, overtemp, fixed	1				
628	122338	SCREW, cap, socket, bh	2				

* Parts included in Wiper Seal Kit 2000706 (purchase separately).

Accessories and Kits

Wiper Kits

Part No.	Description
2000706	KIT, wiper, seal, TOF20, green

Applicators and Dispense Valves

Part No.	Description
249515	Manual Gun, Top Feed, 240V
249514	Manual Gun, Bottom Feed, 240V
249513	Manual Gun, Top Feed, Electric Switch, 240V
249512	Manual Gun, Bottom Feed, Electric Switch, 240V

Air-Operated Heated Dispense Valves

Part No.	Description
243694	Automatic Dispense Valve, 240V, Air-Operated Heated Dispense Valve
244951	Automatic Endure Dispense Valve, 240V, Air-Operated High Flow Heated Dispense Valve
244909	Automatic Endure Dispense Valve, 240V, Air-Operated Snuff-Back Heated Dispense Valve
243701	45 in (114 cm) Distribution Header With Valve, 240V

CGM Installation Kit, 25C994

This kit enables controlling logic, such as a robot controller or PLC continuously monitoring data from the Therm-O-Flow system, as well as optionally controlling the system accordingly. Refer to manual 3A5186 for details on the interface. When ordering this kit, select and order the correct communication gateway module (CGM) that matches the field bus being used. The following CGM modules are available for the Therm-O-Flow system.

Part No.	Description
CGMEP0	EitherNet/IP
CGMDN0	DeviceNet
CGMPB0	ProfiBus
CGMPN0	ProfiNet

Flow Control and Manifolds

Part No.	Description
243700	Heated Air Operated Mastic Pressure Regulator, 240V
243656	23:1 Heated Pressure Compensator Valve, 240V
243657	51:1 Heated Pressure Compensator Valve, 240V
243697	Heated Distribution Manifold, 240V Includes (2) 3/4 npt(f) inlet check valves, (1) npt 4–ported manifold, (2) 1 in npt(f) outlet gate valves, mounting bracket, 400w 230 VAC heaters, RTD sensor, and 8 pin connector box.
289208	Compact Heated Regulator

Accessory Extension Cables

Use to connect fluid control devices and heated hoses to the electrical control enclosure.

Part No.	Description
Connect between controller and heated hose	
129300	15 ft, 12 pin to 12 pin
129301	25 ft, 12 pin to 12 pin
Connect between controller and heated accessory	
129302	15 ft, 12 pin to 8 pin
129303	25 ft, 12 pin to 8 pin
Connect between controller and heated devices	
129703	25 ft, 12 pin to (2) 8 pin
129304	50 ft, 12 pin to (2) 8 pin
Connect between two heated devices	
15C294	30 ft, 8pin to 8 pin

Light Tower Kit 24W589

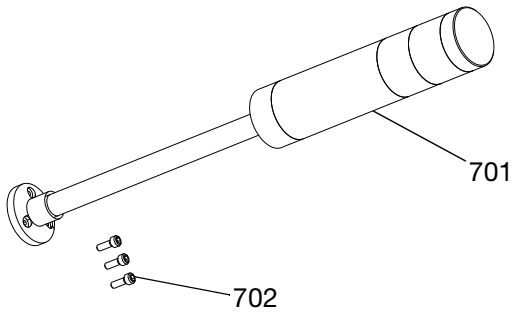

Light Tower Kit 24W589 Parts

Ref.	Part No.	Description	Qty.
701	16K933	LIGHT, tower, red-green, M12	1
702	24V754	SCREW, cap, sch	3

Tie Rod Kits 24V750 and 24V754

Use to retrofit Check-Mate 800 Displacement Pump to an existing Therm-O-Flow system.

Part No.	Description
24V750	Bulldog® and Senator® Tie Rod Kit; see manual 334131
24V754	NXT® Tie Rod Kit; see manual 334132

Overtemperature Jumper 16Y727

Install the overtemperature jumper plug into zone 3-4 to run the Therm-O-Flow without a device installed in these zones.

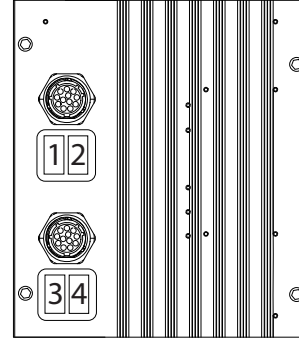

Heated Hoses and Fittings

Hose Diameter	-6 (9/16 in -18 JIC)	-8 (3/4 in -16 JIC)	-10 (7/8 in -14 JIC)	-12 (1-1/16 in -12 JIC)	-16 (1-5/16 in -12 JIC)	-20 (1-5/8 in -12 JIC)
Hose Length						
3 ft (1.5 m)	None	None	None	15C586	None	None
6 ft (1.8 m)	None	115902	115875	None	115884	None
10 ft (3 m)	16J875	115873	115876	115880	115885	117821
15 ft (4.6 m)	None	115874	17J656	115881	115886	117822
20 ft (6 m)	None	None	115878	115882	115887	None
25 ft (7.6 m)	None	None	115879	115883	115888	None
30 ft (9 m)	None	None	121200	None	None	None
Pump Fittings						
TOF 20/200 PUMP 1-11 1/2 DUAL OUTLET ADD 120263	16V432 100380	253267	253268	120260	120261	120262
TOF MINI 5 PUMP 1/2 NPT DUAL OUTLET ADD 120241	16V432	C20678	C20679	C38006	158586	120804 120268
Hose to Hose Fittings						
-6 Hose (.308 ID)	125779	123684	123683	123683 120265	123683 120265 120267	None
-8 Hose (.401 ID)	123684	120241	120242	120244	120244 120267	6308-82 126521
-10 Hose (.495 ID)	123683	120242	120243	120246	120246 120267	6308-82 126521
-12 Hose (.617 ID)	123683 120265	120244	120246	120247	120248	123135 126521
-16 Hose (.687 ID)	123683 120265 120267	120244 120267	120246 120267	120248	120249	120249 120268
-20 Hose (1.125 ID)	None	6308-82 126521	120246 120267 120268	123135 126521	120249 120268	120250
Fittings						
Compensator 51:1, 243657 Compensator 23:1, 243656 Inlet & Outlet: 1-11 1/2 in NPTF	16V432 100380	6308-82	123135 120266	123135	123854	15D936
Distribution manifold, 243697 Inlet: 3/4 in NPTF	16V432 100896	124286	15Y934	C20708	125661	125661 120268
Distribution manifold, 243697 Outlet: 1-11 1/2 in NPTF	16V432 100380	6308-82	123135 120266	123135	123854	15D936

Accessories and Kits

Hose Diameter	-6 (9/16 in -18 JIC)	-8 (3/4 in -16 JIC)	-10 (7/8 in -14 JIC)	-12 (1-1/16 in -12 JIC)	-16 (1-5/16 in -12 JIC)	-20 (1-5/8 in -12 JIC)
Compact Heated Regulator, 289208 Inlet & Outlet: 3/8 in NPTF	16V432 100896	121311	116765	116766	116766 120267	116766 120267 120268
Mastic Regulator, 243700 Inlet & Outlet: 3/4 in NPTF	16V432 100896	124286	15Y934	C20708	125661	125661 120268
Top and bottom feed guns with and without switch, 249512, 249513, 249514, 249515 Inlet: 7/8-14 (JIC -10) male	117677	120264	None	120265	None	None
Standard, High Flow & Snuff-back Dispense valves, 243694, 244951, 244909 Inlet: 1/2 NPTF	16V432	124287	C20768	94/1027/99	125662	125662 120268
Distribution header, 243701 Inlet: 1/2 NPTF	16V432	124287	C20768	94/1027/99	125662	125662 120268
Precision Gear Meter PGM Inlet: 1-5/16-12 o-ring face seal	None	None	None	124238	124239	124240
Precision Gear Meter PGM Outlet: 3/4 NPTF	16V432 100896	124286	15Y934	C20708	125661	125661 120268
PCF Metering System Inlet & Outlet: 3/4 NPTF	16V432 100896	124286	15Y934	C20708	125661	125661 120268

8 Channel Upgrade Kit, 24V755

Use this kit to upgrade a 4 Channel system to an 8 channel system.

Ref	Part	Description	Qty	Ref	Part	Description	Qty
1	---	MODULE, GCA, MZLP	1	5	16W035	CONNECTOR, jumper	1
2	125856	SCREW, 8-32, serrated flange	4	6	17A544	HARNESS, power, MZLP2, AWB	1
3	16T440	CAP, souriau, UTS14	2	7	112190	STRAP, wrist, grounding	1
4	127511	CABLE, board, samtec	1	8	17C712	TOKEN, software upgrade	1

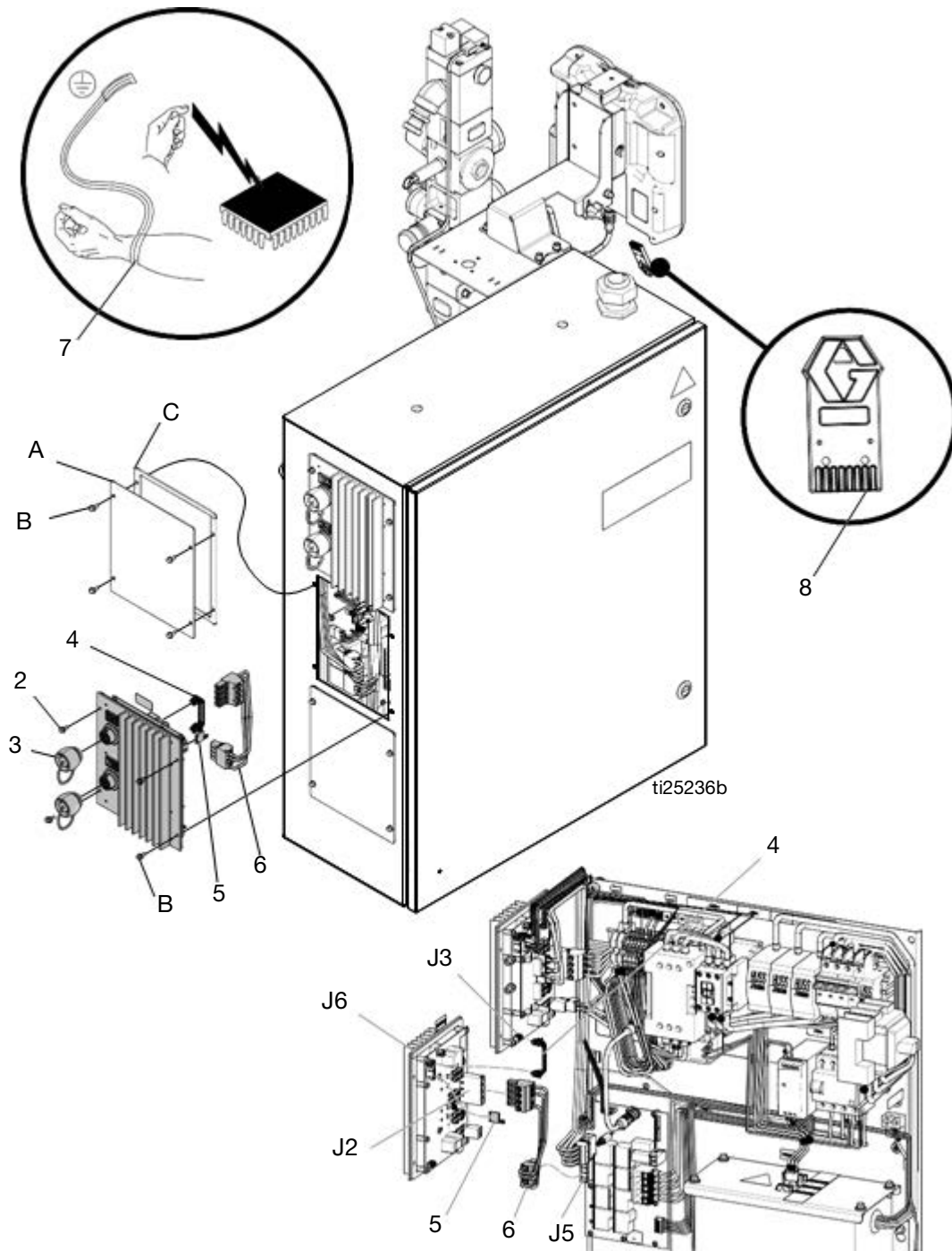

8 Zone Upgrade Kit Installation



1. Disconnect the plug from the power outlet or turn off the Circuit Breaker for incoming power.
2. Place the grounding wrist strap (7) over your wrist and secure the other end to a grounded surface.
3. Set the kit's MZLP (1) rotary switch to "2" on a primary system or "6" on a secondary system.
4. Remove the screws (B), the plate (A), and the gasket (C) from the system. Use the screws (2) to install the MZLP (1) onto the system as shown.

NOTE: The new MZLP (1) will be referred to as MZLP2, and the original MZLP that came with the system will be referred to as MZLP 1.

5. Open the electrical enclosure door.

NOTE: Do not force the electrical connection. Minimal force is required to seat the connector. If resistance is felt, stop, and verify the connector orientation.

6. Connect the cable (4) to the J3 connector on MZLP 1 and the J6 connector on MZLP 2.
7. Connect the power harness (6) to the MZLP 2 J2 connector and the J5 connector on the AWB. Install the jumper (5) on the MZLP 2 J5 connector.
8. Use fittings and hoses that meet your hose routing needs. See **Accessories and Kits**, page 91.
9. To ensure your system has the latest software, insert the token (8) into the ADM. See **Update Software**, page 60.

12 Channel Upgrade Kit, 24V756

Use this kit to upgrade an 8 channel system to a 12 channel system.

Ref	Part	Description	Qty	Ref	Part	Description	Qty
1	---	MODULE, GCA, MZLP	1	6	17A545	HARNESS, power, MZLP2/3, AWB	1
2	125856	SCREW, 8-32, serrated flange	4	7	112190	STRAP, wrist, grounding	1
3	16T440	CAP, souriau, UTS14	2	8	17C712	TOKEN, software upgrade	1
4	127511	CABLE, board, samtec	1				
5	16W035	CONNECTOR, jumper	1				

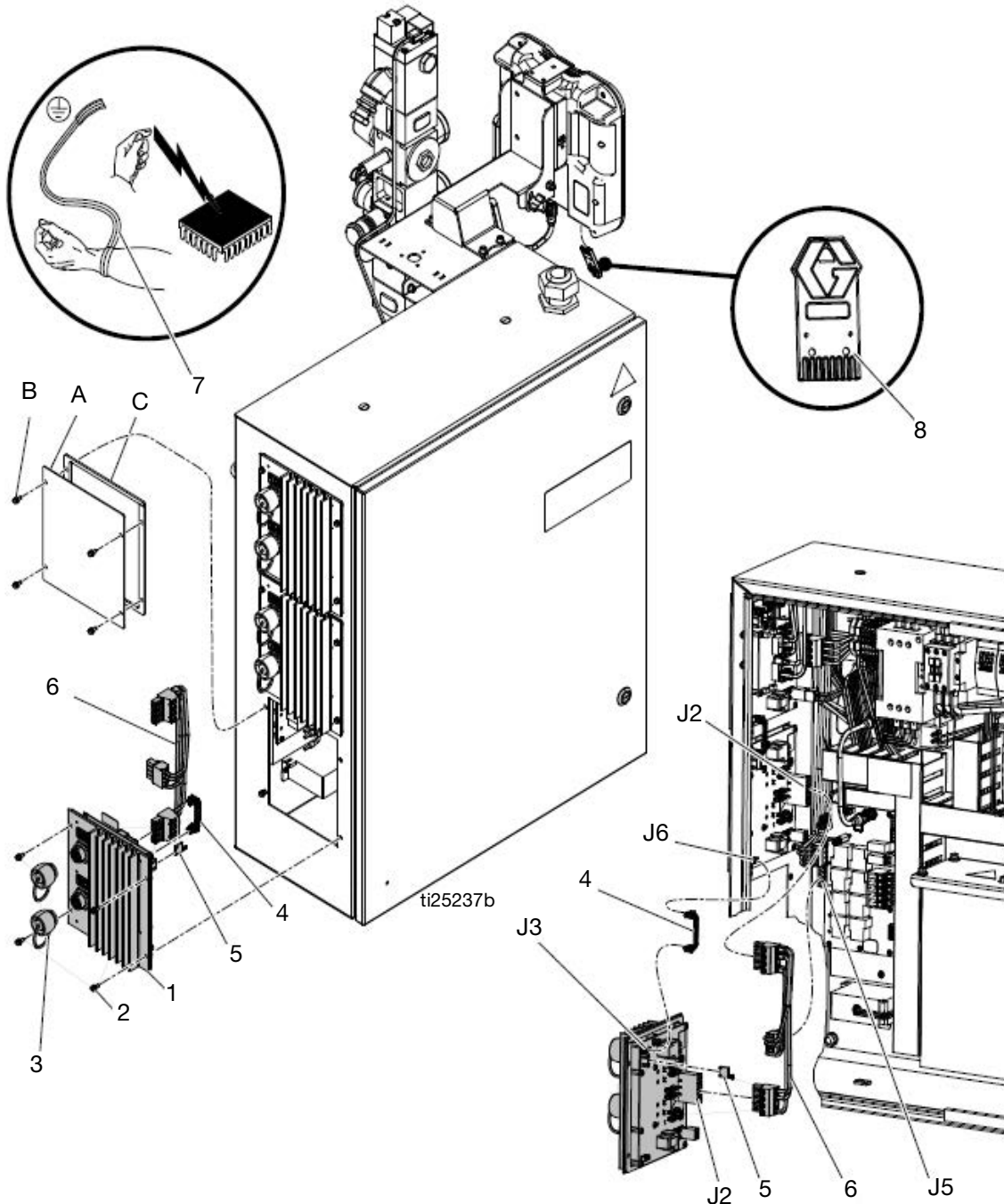

12 Zone Upgrade Kit Installation



1. Disconnect the plug from the power outlet or turn off the Circuit Breaker for incoming power.
2. Place the grounding wrist strap (7) over your wrist and secure the other end to a grounded surface.
3. Set the kit's MZLP (1) rotary switch to "3" on a primary system or "7" on a secondary system.
4. Remove the screws (B), plate (A), and the gasket (C) from the system. Use the screws (2) to install the MZLP (1) on to the system as shown.

NOTE: The new MZLP (1) will be referred to as MZLP 3, and the other two that came with the system will be referred to as MZLP 1 and MZLP 2.

5. Open the electrical enclosure door.

NOTE: Do not force the electrical connection. Minimal force is required to seat the connector. If resistance is felt, stop, and verify the connector orientation.

6. Connect the cable (4) to the J3 connector on MZLP 2 and the J6 connector on MZLP (1). Remove the existing power cable from MZLP 2 J2 and AWB J5 connector.
7. Connect the power harness (6) to MZLP 2 and the MZLP 3 J2 connector and the J5 connector on the AWB.
8. See **Install Heated Hose**, page 17, to connect a heated hose or fluid control device.
9. To ensure your system has the latest software, insert the token (8) into the ADM. See **Update Software**, page 60.

Appendix A - ADM

General Operation

ADM Power

The ADM automatically turns on when the Main Power Switch is ON.

Screen Navigation

To switch between the Setup and Operation screens,

press . Use the keypad to navigate between screens.

Enable, Disable Heating System















To enable or disable the entire heating system, press

. To set which channels are active when the heating system is enabled, use the Heat-A and Heat-B Setup screens.

Icons















Screen Icons

These are frequently used icons on the screens. The following descriptions explain what each icon represents.

Icon	Description
	Primary System= A Secondary System = B
	Heating Disabled
	Warm Up, Actual temperature is outside of Target Temperature
	Reached Target Temperature
	Hose
	Gun
	Manifold
	PGM
	Flow Meter
	Pressure Regulator
	Other
	Advisory. See Error Codes for more information.
	Deviation. See Error Codes for more information.
	Alarm. See Error Codes for more information.

Softkey Icons

The following icons appear in the ADM, directly to the left or right of the soft key which activates that operation.

Icon	Description
	Pause Material Tracking
	Continue Material Tracking
	Pump Ready
	Setback
	Reset Cycle Counter (press and hold)
	Add or edit event
	Accept schedule
	Crossover for Tandem Systems
	Erase or cancel schedule
	Cancel
	Clear
	Schedule Event On/Off
	Heat On/Off
	View Software Contents
	Reprogram token with file from USB stick
	Start USB to Token Programming Process

Operation Screens

Home

This screen shows the temperature state of the system and material usage.

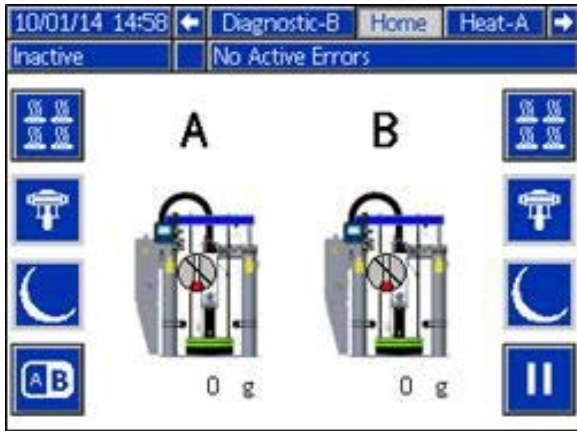

NOTE: If present, secondary systems will be shown on the home page.

Heat A

This screen shows the target and actual temperatures for all zones on the system.

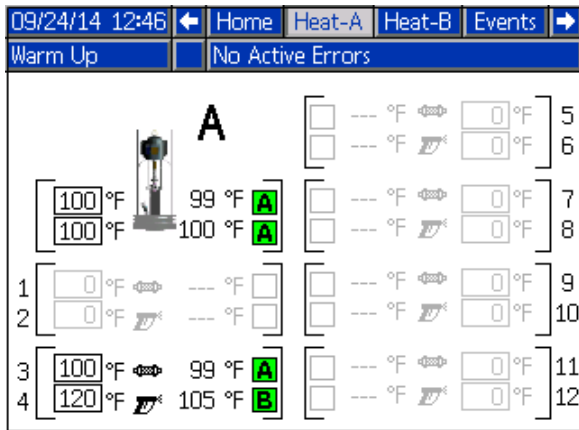

NOTE: The Heat-B screen shows information for an optional secondary system.

NOTE: Mini-5 systems with software version 1.04.042 or later will not display pump data.

Color	A and B Zone Status
White	Off
Green	On and at setpoint temperature
Red	Outside of alarm range
Yellow	Outside of advisory range
Green/Yellow Flashing	Warmup

Events

The Events screens store a maximum of 200 events. The events list can be downloaded in the USB logs. See **Appendix B - USB Data**, page 107.

Date	Time	Code	Description
09/24/14 12:35	12:35	EHTA	At Temp Unit A
09/24/14 12:35	12:35	EHHA	Heat Soak Started Unit A
09/24/14 12:34	12:34	EAAA	Heat On Unit A
09/24/14 12:34	12:34	EBPA	Pump Off Unit A
09/24/14 12:34	12:34	ECDX	Setup Value(s) Changed
09/24/14 12:34	12:34	EAAAB	Heat On Unit B
09/24/14 12:34	12:34	ECDX	Setup Value(s) Changed
09/24/14 12:34	12:34	EAPA	Pump On Unit A
09/24/14 12:34	12:34	EHTA	At Temp Unit A
09/24/14 12:34	12:34	EHHA	Heat Soak Started Unit A

Tracked Events

Custom Language Downloaded
Custom Language Uploaded
Fill Valve Closed
Fill Valve Open
Heat Off
Heat On
Logs Downloaded
Pump Cycles Total Reset
Pump Off
Pump On
Red Stop Button Pressed
Setup Value Changed
System Power Off
System Power On
System Settings Downloaded

Tracked Events
System Settings Uploaded
USB Disabled
USB Drive Inserted
USB Drive Removed
User Maintenance Count Reset

Errors

09/24/14 12:41				Events	Errors	Diagnostic-A
Warm Up				No Active Errors		
Date	Time	Code	Description			
09/24/14	11:00	T3AE	High Temp. Platen	17		
09/24/14	10:54	T3AE	High Temp. Platen	18		
09/24/14	10:50	T6B3	Sensor Err. CH3 Zone	19		
09/24/14	10:50	CAC4	Comm. Error MZLP 4	1		
09/24/14	10:50	CACY	Comm. Error System I/O, Unit B	2		
09/24/14	10:48	T6B3	Sensor Err. CH3 Zone	3		
09/24/14	10:48	V8M4	No Voltage Line MZLP 4	4		
09/24/14	10:48	L2BX	Drum Empty Unit B			
09/24/14	10:48	CAC4	Comm. Error MZLP 4			
09/24/14	10:47	CAC4	Comm. Error MZLP 4			

The Errors screens store a maximum of 200 errors. See **Error Codes**. Download the errors list in the USB logs. See **Appendix B - USB Data**, page 107.

Diagnostic - A

09/24/14 12:55				Diagnostic-A	Home
Heat Ready				No Active Errors	
Pump:	0.00 A	130.6 °F	0 %	ISO DI(0:3)	DI(0:3)
Platen:		121.3 °F	0 %	0000	0001
Zone 1:	0.00 A		0 %	ISO DO(0:3)	DO(0:3)
Zone 2:	0.00 A		0 %	1010	0000
Zone 3:	0.66 A	119.1 °F	4 %	Pump CPM	Pump Sol
Zone 4:	0.00 A		0 %	0	0.00 A
Zone 5:	0.00 A		0 %	Life Cycles	Weight
Zone 6:	0.00 A		0 %	0	0.0 g
Zone 7:	0.00 A		0 %	Heat Soak:	Fan
Zone 8:	0.00 A		0 %	0	0 mA
Zone 9:	0.00 A		0 %	MZLP 1	XFMRTemp
Zone 10:	0.00 A		0 %	84.7 °F	
Zone 11:	0.00 A		0 %	USB DL %	CAN
Zone 12:	0.00 A		0 %	0.0 %	22.596 V

A B C

This screen shows details of various items to aid in troubleshooting the system. This screen can be hidden by de-selecting “Enable Diagnostics Screen” on the System 3 screen. The flow rate updates every 15–20 seconds with average flow rate over the last 15–20 seconds.

NOTE: Diagnostic - B shows information for an optional secondary system.

The following information is displayed.

	Diagnostic Data
A	Current Draw
B	RTD Reading
C	Duty Cycle

CAN: 24 VDC power supply voltage reading (18-28 VDC)

DI: System Digital Inputs

- 0: Drum Empty
- 1: Drum Low
- 2: Pump Cycle Switch Up
- 3: Pump Cycle Switch Down

DO: System Digital Outputs

- 0: Pump Solenoid
- 1: Not Used
- 2: Not Used
- 3: Not Used

ISO DI: Customer Digital Inputs

See **Connect PLC (Hard Wired Interface Version)**, page 25.

ISO DO: Customer Digital Outputs

See **Connect PLC (Hard Wired Interface Version)**, page 25.

Fan: Current to fan

Heat Soak: Set time for Platen to heat after the Platen has reached set temperature.

Life Cycles: Total number of pump cycles over the life of the system.

MZLP 1: Temperature on MZLP 1.

- 32-160°F (0-71°C)

Pump Sol: Current draw of Pump solenoid.

- (0 mA - off)
- (150-250 mA - on)

Pump CPM: Pump cycles per minute.

USB DL%: Percentage complete, only applies when downloading USB data. 5 downloads will occur.

Weight: Weight of material dispensed over the life of the system.

XFMRTemp: Temperature of the Transformer temperature sensor.

Setup Screens

NOTE: It is important to set all settings in the System screens correctly to ensure optimal system performance.

Password

If the password is not “0000”, the password must be entered to access the setup screens.

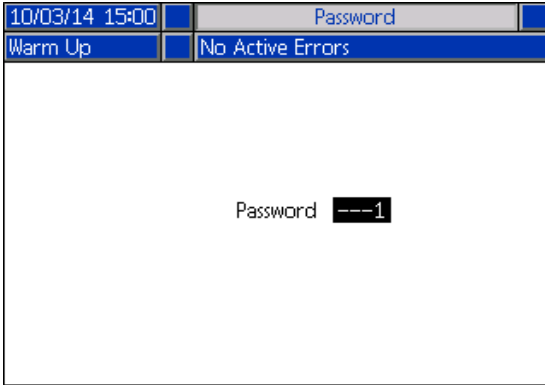

System 1

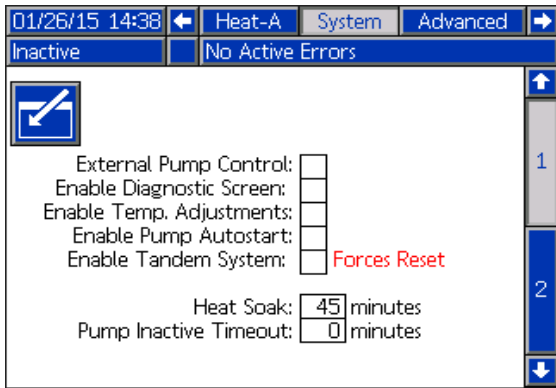

External Pump Control: Enable feature that automatically turns on and off the Pump when using a handheld dispense gun with an integrated trigger switch.

Enable Diagnostic Screen: Choose whether to show the Diagnostic screen.

Enable Temp. Adjustments: Allows temperature adjustments on the Heat-A and Heat-B Run screens.

Enable Pump Autostart: Automatically turns the Pump on after reaching setpoint temperature and heat soak is complete.

Enable Tandem System: Enable all secondary system

ADM screens.

Heat Soak: Time for to preheat after all zones have reached their target temperatures. Pump cannot turn on until timer is complete. The heat soak is a user-defined time.

- Range: 1-120 minutes
- 0 disables heat soak

Pump Inactive Timeout: If no Pump movement is detected or either Pump for (x) amount of time, all heated zones enter setback mode. After an additional amount of time (x), the heat will turn off.

- (x) Range: 0-120 minutes
- 0 disables heat soak

NOTE: The pump inactive timeout will not be displayed on Mini-5 systems with software versions 1.04.042 or later.

System 2

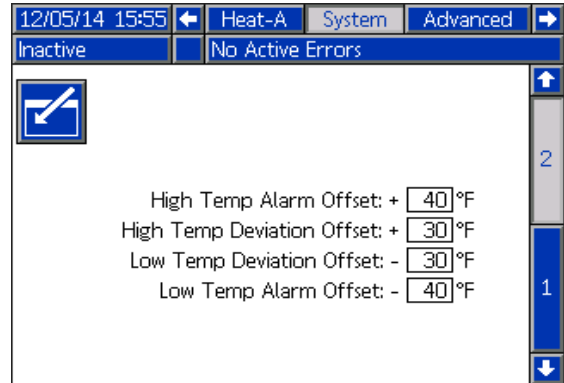

Enter low and high temperatures for an alarm or warning to occur.

Advanced 1

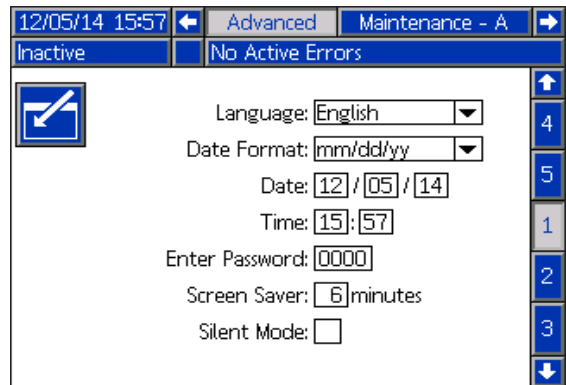

Language: Language displayed on the screen.

Date Format: Choose the format of the date.

Date: Set the date.

Time: Set the time.

Enter Password: If not “0000”, the Setup screens will be password protected.

Screen Saver: The screen will go black after the set amount of time.

Silent Mode: Disable ADM sounds.

Advanced 2

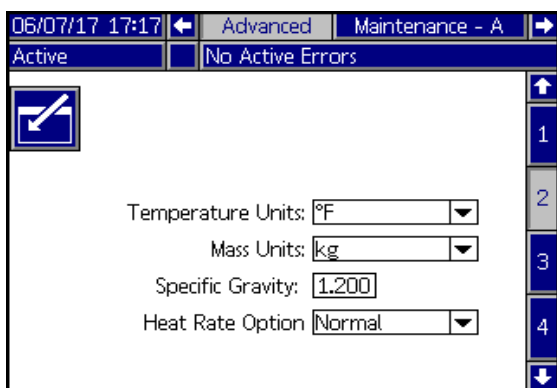

Temperature Units: Units of measure for displayed temperatures.

Mass Units: Units of measure for mass.

Specific Gravity: Required to convert the volume dispensed to mass dispensed for tracking the total weight and flow rate. When the specific gravity value is populated, the total mass dispense since the last total weight reset is shown on the Home screen and the mass flow rate is shown on the Diagnostic screen.

NOTE: If the Specific Gravity is set to zero, the Home screen will display a cycle counter instead of grams or pounds.

Heat Rate Option: Control option where the user can select the rate at which heat is applied to all zones enabled or selected. Three options are available, Normal (default), Fast, and Slow. The Warm Up system time would be shortest for the Fast option, then the Normal, and longest if the Slow option is selected. If the material set temperatures are less than 200° F (93° C), the Slow option may be best for the application.

Advanced 3

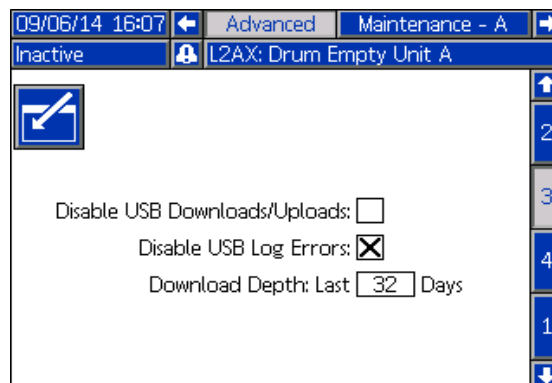

Disable USB Downloads/Uploads: Disables use of the USB for downloading and uploading.

Disable USB Log Errors: When disabled, the system will not warn the user when logs are full. If the logs are full, the oldest data will be overwritten.

Download Depth: Last _ Days: The USB download will provide data as old as the number of days entered. Old data may be in memory but will not be downloaded if older than the number of days entered.

Advanced 4

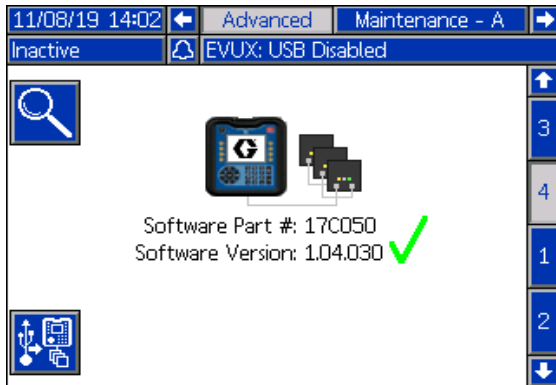

Advanced 4 screen allows the user to view the software contents within the Therm-O-Flow system, or to reprogram the system with a software update.

To view the software contents, press the  soft key icon. The screen will display the system software part numbers and version numbers as shown below.

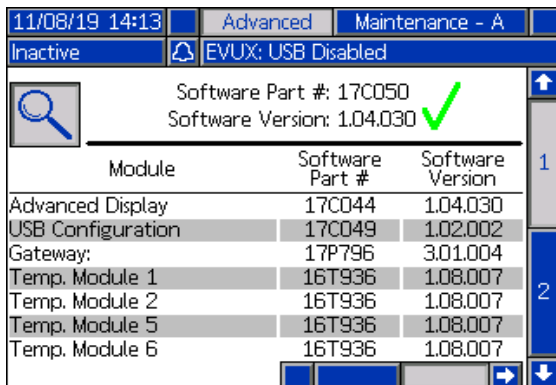



If the software contents do not fit onto one screen, the user can navigate down to the next page by pressing the down arrow key.

Press the right arrow key to view the serial numbers of the software displayed on the next screen.

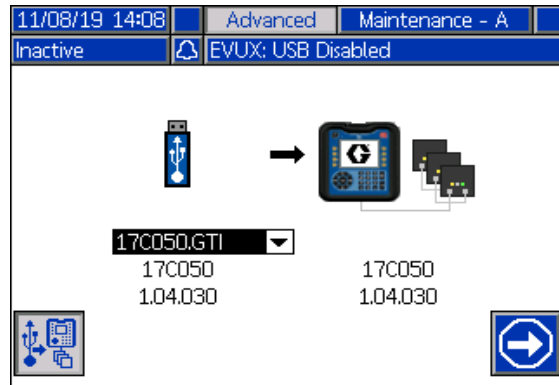
To reprogram the system with updated software, press the  soft key icon on the main Advanced 4 screen. The screen will appear as shown below.



To update the software:

1. Transfer the updated TOF .gti file (with a filename containing "17C050") onto a USB stick. Place the file in a "\GRACO\SOFTWARE\" subdirectory.
2. Insert a black programming token into the token slot of the ADM.
3. Insert the USB stick into the USB slot of the ADM. If the USB download option is selected, a graphic of a USB stick will appear after the download process is completed. The graphic will appear with a pull-down option control which allows the user to select the file to transfer to the programming token.
4. If more than one Therm-O-Flow .gti file is present in the "GRACO/SOFTWARE/" directory on the USB stick, select the correct file to transfer using the pull-down selection control.
5. Press the  soft key icon to start the USB to token programming process.
6. During the file transfer process, a progress bar will be displayed with a percentage completed indicator below. This step may take a few minutes to complete.
7. Once the percentage indicator reached 100%, the bottom right soft key will change to . Press the  soft key to update the system. To update the system (or another Therm-O-Flow system) at a later time, remove the token and reinsert it with a power cycle.

To exit the screen, press the "X" key until the main home run screen is shown.

Heat - A

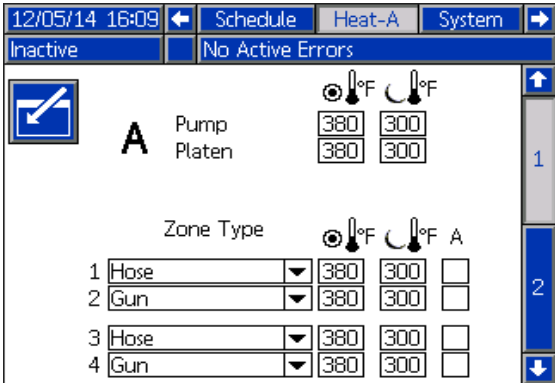

Use these screens to set target and setback temperatures for the Pump, Platen, and zones. Select which system needs to use the heated accessory.

Zone Types:

- Hose
- Gun
- PGM
- Flowmeter
- Pressure Regulator
- Manifold
- Other

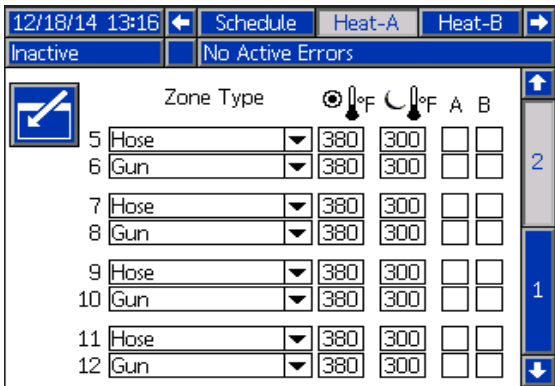

NOTE: To ensure accurate hose and gun temperatures, set hose as zone 1, 3, 5, 7, 9, or 11 when connected to MZLP and a heated hose.

NOTE: Pump settings will not be displayed on Mini-5 systems with software versions 1.04.042 or later.

Maintenance - A

09/06/14 16:12 Maintenance - A Schedule

Inactive L2AX: Drum Empty Unit A

User Due Interval Cycles

Pump Current Lifetime Cycles

Weight 0.0 g

The system will notify the user at the set interval that maintenance is required. The fields in boxes can be edited by the user. “Due” and “Current” are both the number of cycles since the last reset. “Interval” is the set number of cycles between maintenance notifications. “Lifetime” is the number of cycles in the lifetime of the system.

NOTE: The lifetime cycle count will only be reset if the ADM is replaced.

NOTE: Maintenance screens will not be displayed on Mini-5 systems with software versions 1.04.042 or later.

Schedule

09/06/14 16:14 Schedule Heat-A

Inactive L2AX: Drum Empty Unit A

	Mon	Tue	Wed	Thu	Fri	Sat	Sun
06:00	06:00	06:00					
14:00	11:00	11:00					
	12:00	12:00					
	16:00	16:00					

Use this screen to set times that the system will automatically enable and disable heating. See

Schedule, page 36.

Gateway 1 and 2

If the Therm-O-Flow system has a communication gateway module (CGM) installed, an additional “Gateway” chapter containing 1 or 2 pages will be available in the setup screens. These pages enable the user to set the CGM IP or device address, configure the field bus protocol selections, and enable the user to view the mapping information programmed into the CGM module. The screens shown below illustrate the 2 pages provided if an Ethernet I/P CGM module is installed. Refer to manual 3A5186 for information on mapping and the screens available for the other field bus options.

06/07/17 17:20 Schedule Gateway Heat-A

Inactive No Active Errors

EtherNet/IP

IP Address: 010|010|020|014

DHCP: No

Subnet Mask: 255|255|255|000

Gateway: 000|000|000|000

DNS 1: 000|000|000|000

DNS 2: 000|000|000|000

06/07/17 17:22 Schedule Gateway Heat-A

Inactive No Active Errors

EtherNet/IP

Hardware Revision: 0000

System Serial #: 00000000

Map ID: 00001

Map Name: TOF_Tndm

Map Revision: 001.003

Map Date: 05/10/17

Appendix B - USB Data

The system can store 250,000 entries in its logs and the system adds a new entry to the logs every 15 seconds. This means the system stores 1041 hours of system operation data, or 43 days of around-the-clock operation. Once full, the system will overwrite the oldest data.

NOTE: To prevent losing any data, never go more than 43 days without downloading the logs.

Download

NOTICE

Uploading an edited system configuration file can damage the system. Never put a modified SETTINGS.TXT file in the UPLOAD folder on the flash drive.

NOTE: The event log, error log, system settings, and system language files are all downloaded in this procedure.

1. Insert USB flash drive into USB port.

NOTE: Flash drive must be 8 GB or smaller.

2. The menu bar and USB indicator lights indicate that the USB is downloading files. Wait for USB activity to complete. A pop-up will be present until the transfer is complete if it is not acknowledged.

NOTE: If the pop-up screen does not appear, the flash drive is not compatible with the ADM. Try a different flash drive.

NOTE: The system can log up to 45 mb of additional data per week, depending on system operation.

Access Files

All files downloaded from the USB are put in a DOWNLOAD folder on the stick drive. For example: "E:\GRACO\12345678\DOWNLOAD\". The 8-digit numeric folder name matches the 8-digit ADM serial number, which is located on the back of the ADM. When downloading from multiple ADMs, there will be one sub-folder in the GRACO folder for each ADM.

The log files should be opened in a spreadsheet program.

NOTE: If emailing the files, zip (compress) them to minimize file size.

Upload

Upload a system configuration file and/or a custom language file. See **System Settings File**, page 108 or **System Language File**, page 109.

1. If necessary, follow the **Download Instructions**, page 107, to automatically generate the proper folder structure on the USB flash drive.
2. Insert USB flash drive into USB port of computer.
3. The USB flash drive window automatically opens. If it does not, open USB flash drive from within Windows Explorer.
4. Open Graco folder.
5. Open system folder. If working with more than one system, there will be more than one folder within the Graco folder. Each folder is labeled with the corresponding serial number of the ADM. (The serial number is on the back of the module.)
6. *If installing the system settings file*, place SETTINGS.TXT file into UPLOAD folder.
7. *If installing the custom language file*, place DISPTXT.TXT file into UPLOAD folder.
8. Remove USB flash drive from computer.
9. Install USB flash drive into Therm-O-Flow system USB port.
10. The menu bar and USB indicator lights indicate that the USB is uploading files. Wait for USB activity to complete.

11. Remove USB flash drive from USB port.

NOTE: If a custom language file was installed, users can now select the new language from the Language drop-down menu.

NOTE: If the SETTINGS.TXT or DISPTXT.TXT files remain in the UPLOAD folder, they will be uploaded every time the USB drive is inserted into the corresponding ADM. To avoid unintentionally overwriting system settings, delete the files from the UPLOAD folders on the USB drive after the upload is complete.

USB Logs

During operation, the Therm-O-Flow stores system and performance related information to memory in the form of log files. The Therm-O-Flow maintains the events, data, GCA, Black Box, and Diagnostics logs. Follow the **Download Procedure**, page 107, to retrieve log files.

Events Log

The event log (1-EVENT.CSV) maintains a record of the last 175,000 events. Each event record in the log file contains the date and time the event occurred, the event type, event code, and event description.

Data Log

The data log (2-DATA.CSV) tracks the setpoint and actual temperatures every 15 seconds. This log can store up to 250,000 lines of data.

The system stores 1041 hours of system operation data, or 43 days of around-the-clock operation. Once full, the system will overwrite the oldest data.

Change Log

The change log (3-CHANGE.CSV) tracks the changes to setpoint and setback temperatures.

GCA Log

This log (4-GCA.CSV) lists the installed GCA modules and their respective software versions.

Black Box, Diagnostics Log

These logs (5-BLACKB.CSV, 6-DIAGN.CSV) are designed to provide useful information to Graco when calling for technical assistance.

System Settings File

NOTICE

Uploading an edited system configuration file can damage the system. Never put a modified SETTINGS.TXT file in the UPLOAD folder on the flash drive.

The system configuration settings file name is SETTINGS.TXT and is stored in the DOWNLOAD folder.

A system configuration settings file automatically downloads each time a USB flash drive is inserted. Use this file to back up system settings for future recovery or to easily replicate settings across multiple Therm-O-Flow systems. Refer to the **Upload Instructions**, page 107, for how to use this file.

It is recommended to retrieve the SETTINGS.TXT file after all system settings are set as desired. Store the file for future use as a backup in case the settings are changed and need to be quickly changed back to the desired setup.

System Language File

The system language file name is DISPTXT.TXT and is stored in the DOWNLOAD folder.

A system language file automatically downloads each time a USB flash drive is inserted. If desired, use this file to create a user-defined set of custom language strings to be displayed within the ADM.

The system is able to display the following Unicode characters. For characters outside of this set, the system will display the Unicode replacement character, which appears as a white question mark inside of a black diamond.

- U+0020 - U+007E (Basic Latin)
- U+00A1 - U+00FF (Latin-1 Supplement)
- U+0100 - U+017F (Latin Extended-A)
- U+0386 - U+03CE (Greek)
- U+0400 - U+045F (Cyrillic)

Create Custom Language Strings

The custom language file is a tab-delimited text file that contains two columns. The first column consists of a list of strings in the language selected at the time of download. The second column can be used to enter the custom language strings. If a custom language was previously installed, this column contains the custom strings. Otherwise the second column is blank.

Modify the second column of the custom language file as needed and then follow the **Upload Instructions**, page 107, to install the file.

The format of the custom language file is critical. The following rules must be followed in order for the installation process to succeed.

1. The file name must be DISPTXT.TXT.
2. The file format must be a tab-delimited text file using Unicode (UTF-16) character representation.
3. The file must contain only two columns, with columns separated by a single tab character.
4. Do not add or remove rows to the file.
5. Do not change the order of the rows.
6. Define a custom string for each row in the second column.

Dimensions

Ram Mounting and Clearance

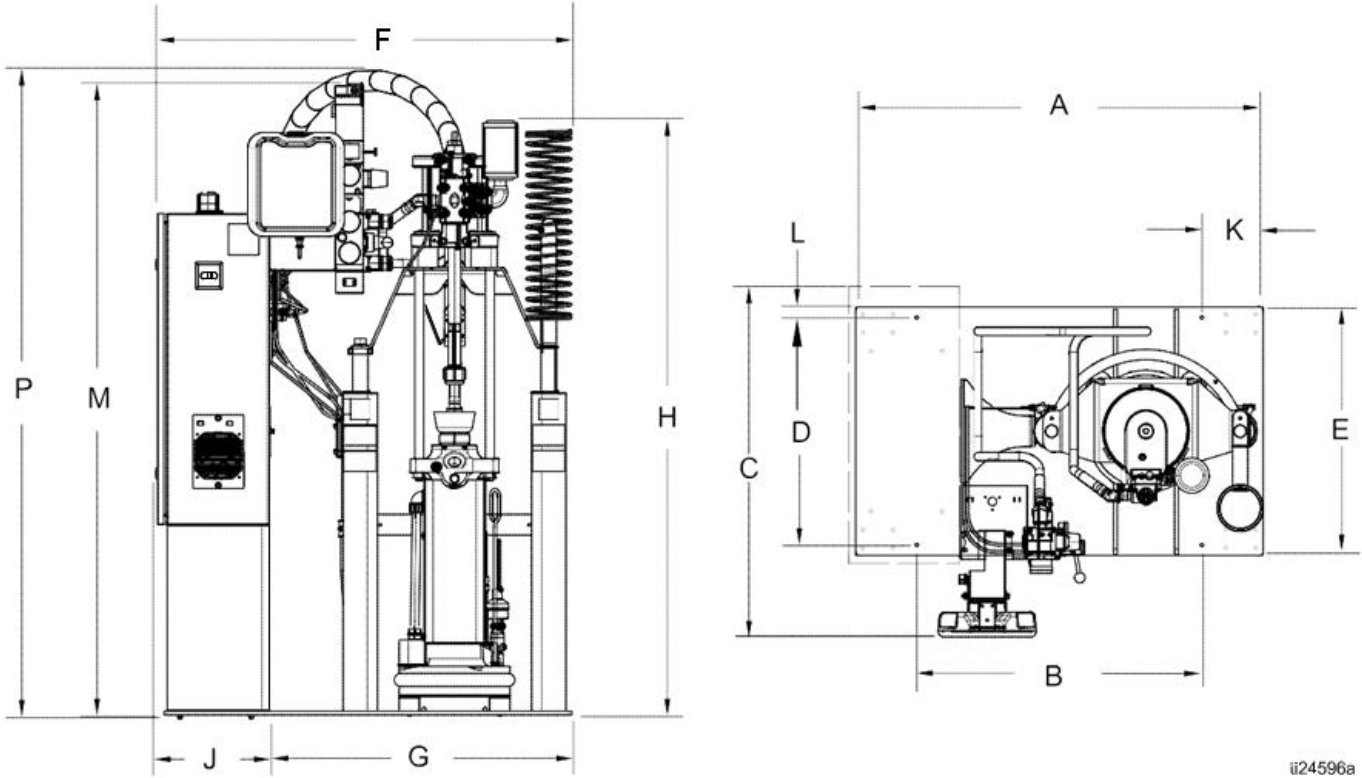

ü24596a

A	B	C	D	E	F	G	J	K	L	M	P
in. (mm)	in. (mm)	in. (mm)	in. (mm)	in. (mm)	in. (mm)	in. (mm)	in. (mm)	in. (mm)	in. (mm)	in. (mm)	in. (mm)
40 (1016)	28 (711)	36 (914)	22 (558)	24 (609)	40.8 (1036)	29.7 (754)	11 (279)	6 (152)	1 (25.4)	60 (1524)	62 (1574)

Height (H)	Dimensions
Fully Raised	74.3 in (1887 mm)
Fully Lowered	57.3 in (1455 mm)

15:1

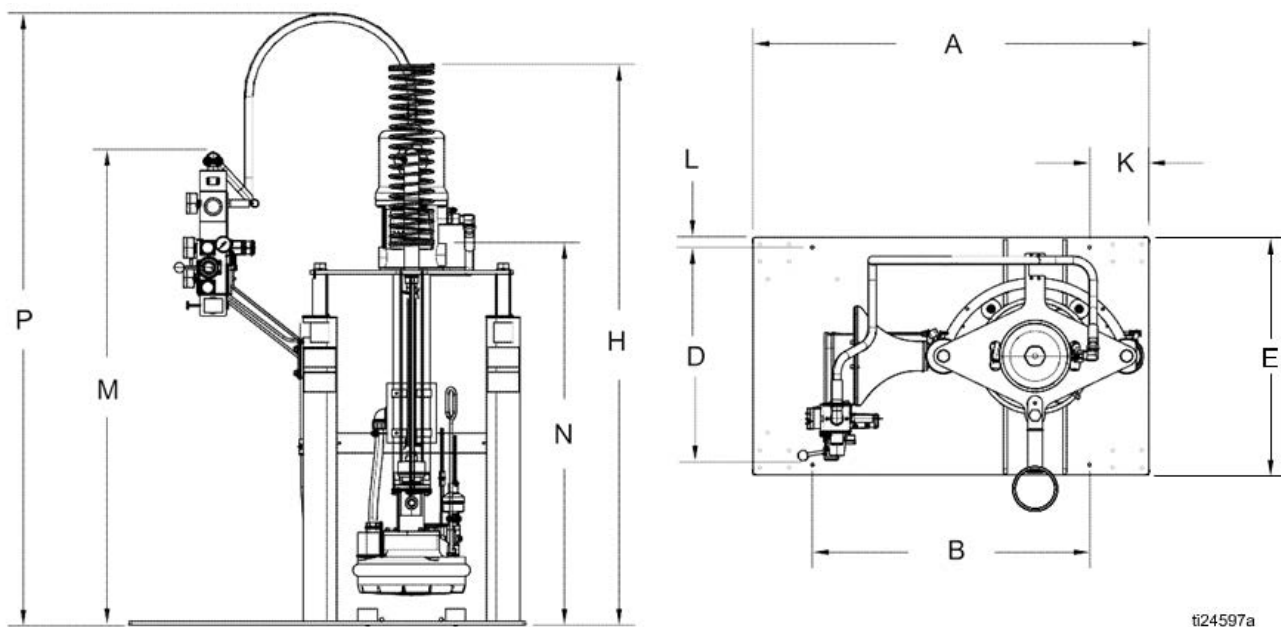

ti24597a

A	B	D	E	G	K	L	M	N	P
in. (mm)	in. (mm)	in. (mm)	in. (mm)	in. (mm)	in. (mm)	in. (mm)	in. (mm)	in. (mm)	in. (mm)
40 (1016)	28 (711)	22 (558)	24 (609)	29.7 (754)	6 (152)	1 (25.4)	48 (1219)	38.5 (977)	62 (1574)

Height (H)	Dimensions
Fully Raised	73.5 in (1866 mm)
Fully Lowered	56.5 in (1435 mm)

Technical Specifications

Therm-O-Flow 20 Hot Melt System		
	U.S.	Metric
Air inlet size	1/2 npsm(f)	
Air motor sound data	See Air Motor instruction manual.	
Wetted Parts	carbon steel, brass, chrome, zinc, nickel plating, stainless steel (304, 316, 440, and 17-4 PH), alloy steel, ductile iron, PTFE	
Displacement Pump Effective Area		
Merkur and NXT	1.24 in ²	8 cm ²
President	0.884 in ²	5.7 cm ²
Volume per Cycle		
Merkur and NXT	11.7 in ³	192 cm ³
President	3.8 in ³	62.3 cm ³
Pump Cycles per 1 Gallon (3.8 liters)		
Merkur and NXT	21	
President	61	
Ram Maximum Input Pressure		
Merkur and NXT	100 psi	0.7 MPa, 7 bar
President	100 psi	0.7 MPa, 7 bar
President 4.25 in	100 psi	0.7 MPa, 7 bar
Maximum Pump Operating Temperature		
Merkur and NXT	400°F	204°C
President	400°F	204°C
Pump Fluid Outlet Size		
Merkur and NXT	1 in npt(f)	
President	1/2 in npt(f)	
Maximum Fluid Working Pressure		
23:1	2300 psi	15.9 MPa, 159 bar
36:1	3000 psi	20.7 MPa, 207 bar
70:1	3000 psi	20.7 MPa, 207 bar
President 4.25 in	1800 psi	12.6 MPa, 125 bar
Maximum Air Input Pressure (Pumps)		
23:1	100 psi	0.7 MPa, 7 bar
36:1	82 psi	0.57 MPa, 5.7 bar
70:1	43 psi	0.29 MPa, 2.9 bar
President 4.25 in	120 psi	0.8 MPa, 8.3 bar
Power Requirements		
Compressed Air (typical)	25–50 scfm	

Therm-O-Flow 20 Hot Melt System	
Voltage (as selected)	220/240 V, 3-phase, 50/60 Hz
	380/400 V, 3-phase, 50/60 Hz
	470/490 V, 3-phase, 50/60 Hz
	575 V, 3-phase, 50/60 Hz
Peak Consumption <i>(includes drum melt grid, pump, and a 6kVa transformer for the 230 V hoses and accessories)</i>	
Standard melt grid platen with President pump	6.4 kVa
Standard melt grid platen with Merkur or NXT pump	8.7 kVa
Smooth melt grid platen with President pump	6.4 kVa
Smooth melt grid platen with Merkur or NXT pump	8.7 kVa

Graco Standard Warranty

Graco warrants all equipment referenced in this document which is manufactured by Graco and bearing its name to be free from defects in material and workmanship on the date of sale to the original purchaser for use. With the exception of any special, extended, or limited warranty published by Graco, Graco will, for a period of twelve months from the date of sale, repair or replace any part of the equipment determined by Graco to be defective. This warranty applies only when the equipment is installed, operated and maintained in accordance with Graco's written recommendations.

This warranty does not cover, and Graco shall not be liable for general wear and tear, or any malfunction, damage or wear caused by faulty installation, misapplication, abrasion, corrosion, inadequate or improper maintenance, negligence, accident, tampering, or substitution of non-Graco component parts. Nor shall Graco be liable for malfunction, damage or wear caused by the incompatibility of Graco equipment with structures, accessories, equipment or materials not supplied by Graco, or the improper design, manufacture, installation, operation or maintenance of structures, accessories, equipment or materials not supplied by Graco.

This warranty is conditioned upon the prepaid return of the equipment claimed to be defective to an authorized Graco distributor for verification of the claimed defect. If the claimed defect is verified, Graco will repair or replace free of charge any defective parts. The equipment will be returned to the original purchaser transportation prepaid. If inspection of the equipment does not disclose any defect in material or workmanship, repairs will be made at a reasonable charge, which charges may include the costs of parts, labor, and transportation.

THIS WARRANTY IS EXCLUSIVE, AND IS IN LIEU OF ANY OTHER WARRANTIES, EXPRESS OR IMPLIED, INCLUDING BUT NOT LIMITED TO WARRANTY OF MERCHANTABILITY OR WARRANTY OF FITNESS FOR A PARTICULAR PURPOSE.

Graco's sole obligation and buyer's sole remedy for any breach of warranty shall be as set forth above. The buyer agrees that no other remedy (including, but not limited to, incidental or consequential damages for lost profits, lost sales, injury to person or property, or any other incidental or consequential loss) shall be available. Any action for breach of warranty must be brought within two (2) years of the date of sale.

GRACO MAKES NO WARRANTY, AND DISCLAIMS ALL IMPLIED WARRANTIES OF MERCHANTABILITY AND FITNESS FOR A PARTICULAR PURPOSE, IN CONNECTION WITH ACCESSORIES, EQUIPMENT, MATERIALS OR COMPONENTS SOLD BUT NOT MANUFACTURED BY GRACO. These items sold, but not manufactured by Graco (such as electric motors, switches, hose, etc.), are subject to the warranty, if any, of their manufacturer. Graco will provide purchaser with reasonable assistance in making any claim for breach of these warranties.

In no event will Graco be liable for indirect, incidental, special or consequential damages resulting from Graco supplying equipment hereunder, or the furnishing, performance, or use of any products or other goods sold hereto, whether due to a breach of contract, breach of warranty, the negligence of Graco, or otherwise.

FOR GRACO CANADA CUSTOMERS

The Parties acknowledge that they have required that the present document, as well as all documents, notices and legal proceedings entered into, given or instituted pursuant hereto or relating directly or indirectly hereto, be drawn up in English. Les parties reconnaissent avoir convenu que la rédaction du présente document sera en Anglais, ainsi que tous documents, avis et procédures judiciaires exécutés, donnés ou intentés, à la suite de ou en rapport, directement ou indirectement, avec les procédures concernées.

Graco Information

For the latest information about Graco products, visit www.graco.com.

For patent information, see www.graco.com/patents.

TO PLACE AN ORDER, contact your Graco distributor or call to identify the nearest distributor.

Toll Free Phone Number: 1-800-328-0211

All written and visual data contained in this document reflects the latest product information available at the time of publication. Graco reserves the right to make changes at any time without notice.

Original instructions. This manual contains English. MM 334129

Graco Headquarters: Minneapolis

International Offices: Belgium, China, Japan, Korea

GRACO INC. AND SUBSIDIARIES • P.O. BOX 1441 • MINNEAPOLIS MN 55440-1441 • USA
Copyright 2016, Graco Inc. All Graco manufacturing locations are registered to ISO 9001.

www.graco.com
Revision W, February 2025