

# Nova™ 390 Stand/Nova™ 390 ProStep™ Electric Airless Sprayer

312859A

- For portable spray application of architectural paints and coatings -

**Models: 826084, 826098**

Maximum Working Pressure: 3300 psi (227 bar, 22.7 MPa)



**IMPORTANT SAFETY INSTRUCTIONS!**

**Read all warnings and instructions.** Save these instructions. Contact Graco Customer Service or your local Graco distributor to obtain a manual in your language.

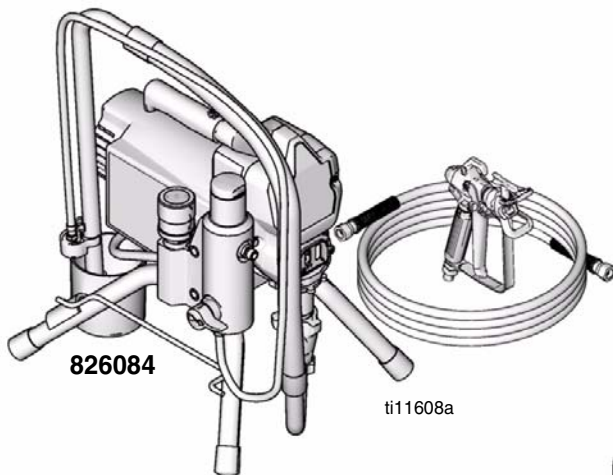

826084

ti11608a

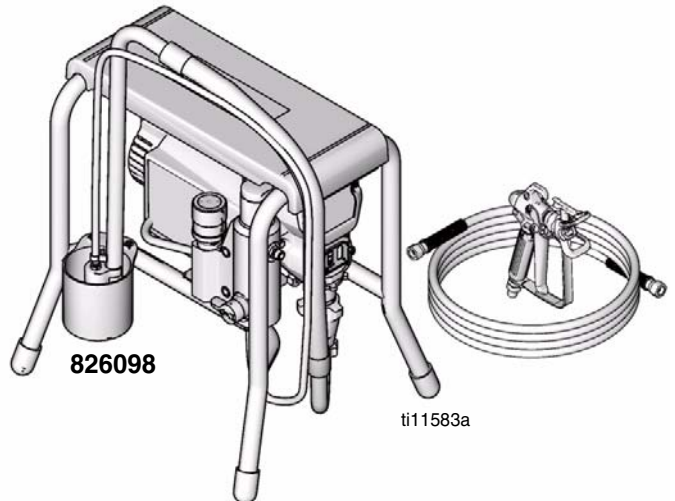

826098

ti11583a

**Related Manuals**



312858



309639



309250



312860

PROVEN QUALITY. LEADING TECHNOLOGY.

# Warning

The following warnings are for the setup, use, grounding, maintenance and repair of this equipment. The exclamation point symbol alerts you to a general warning and the hazard symbol refers to procedure-specific risks. Refer back to these warnings. Additional, product-specific warnings may be found throughout the body of this manual where applicable.

## Grounding Instructions

This product must be grounded. In the event of an electrical short circuit, grounding reduces the risk of electric shock by providing an escape wire for the electric current. This product is equipped with a cord having a grounding wire with an appropriate grounding plug. The plug must be plugged into an outlet that is properly installed and grounded in accordance with all local codes and ordinances.

### WARNING



#### GROUNDING

- Improper installation of the grounding plug is able to result in a risk of electric shock.
- When repair or replacement of the cord or plug is required, do not connect the grounding wire to either flat blade terminal.
- The wire with insulation having an outer surface that is green with or without yellow stripes is the grounding wire.
- Check with a qualified electrician or serviceman when the grounding instructions are not completely understood, or when in doubt as to whether the product is properly grounded.
- Do not modify the plug provided; if it does not fit the outlet, have the proper outlet installed by a qualified electrician.
- This product is for use on a nominal 120V circuit and has a grounding plug similar to the plug illustrated in the figure below.

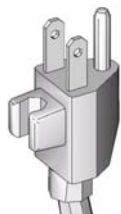

- Only connect the product to an outlet having the same configuration as the plug.
- Do not use an adapter with this product.

#### Extension Cords:

- Use only a 3-wire extension cord that has a 3-blade grounding plug and a 3-slot receptacle that accepts the plug on the product.
- Make sure your extension cord is not damaged. If an extension cord is necessary, use 12 AWG (2.5 mm<sup>2</sup>) minimum to carry the current that the product draws.
- An undersized cord results in a drop in line voltage and loss of power and overheating.













**WARNING**
**FIRE AND EXPLOSION HAZARD**

Flammable fumes, such as solvent and paint fumes, in work area can ignite or explode. To help prevent fire and explosion:

- Do not spray flammable or combustible materials near an open flame or sources of ignition such as cigarettes, motors, and electrical equipment.
- Paint or solvent flowing through the equipment is able to result in static electricity. Static electricity creates a risk of fire or explosion in the presence of paint or solvent fumes. All parts of the spray system, including the pump, hose assembly, spray gun, and objects in and around the spray area shall be properly grounded to protect against static discharge and sparks. Use Graco conductive or grounded high-pressure airless paint sprayer hoses.
- Verify that all containers and collection systems are grounded to prevent static discharge.
- Connect to a grounded outlet and use grounded extensions cords. Do not use a 3-to-2 adapter.
- Do not use a paint or a solvent containing halogenated hydrocarbons.
- Keep spray area well-ventilated. Keep a good supply of fresh air moving through the area. Keep pump assembly in a well ventilated area. Do not spray pump assembly.
- Do not smoke in the spray area.
- Do not operate light switches, engines, or similar spark producing products in the spray area.
- Keep area clean and free of paint or solvent containers, rags, and other flammable materials.
- Know the contents of the paints and solvents being sprayed. Read all Material Safety Data Sheets (MSDS) and container labels provided with the paints and solvents. Follow the paint and solvents manufacturer's safety instructions.
- Fire extinguisher equipment shall be present and working.
- Sprayer generates sparks. When flammable liquid is used in or near the sprayer or for flushing or cleaning, keep sprayer at least 20 feet (6 m) away from explosive vapors.

**SKIN INJECTION HAZARD**

- Do not aim the gun at, or spray any person or animal.
- Keep hands and other body parts away from the discharge. For example, do not try to stop leaks with any part of the body.
- Always use the nozzle tip guard. Do not spray without nozzle tip guard in place.
- Use Graco nozzle tips.
- Use caution when cleaning and changing nozzle tips. In the case where the nozzle tip clogs while spraying, follow the **Pressure Relief Procedure** for turning off the unit and relieving the pressure before removing the nozzle tip to clean.
- Do not leave the unit energized or under pressure while unattended. When the unit is not in use, turn off the unit and follow the **Pressure Relief Procedure** for turning off the unit.
- High-pressure spray is able to inject toxins into the body and cause serious bodily injury. In the event that injection occurs, **get immediate surgical treatment.**
- Check hoses and parts for signs of damage. Replace any damaged hoses or parts.
- This system is capable of producing 3300 psi. Use Graco replacement parts or accessories that are rated a minimum of 3300 psi.
- Always engage the trigger lock when not spraying. Verify the trigger lock is functioning properly.
- Verify that all connections are secure before operating the unit.
- Know how to stop the unit and bleed pressure quickly. Be thoroughly familiar with the controls.

 <b>WARNING</b>	
	<p><b>EQUIPMENT MISUSE HAZARD</b></p> <p>Misuse can cause death or serious injury.</p> <ul style="list-style-type: none"> <li>• Always wear appropriate gloves, eye protection, and a respirator or mask when painting.</li> <li>• Do not operate or spray near children. Keep children away from equipment at all times.</li> <li>• Do not overreach or stand on an unstable support. Keep effective footing and balance at all times.</li> <li>• Stay alert and watch what you are doing.</li> <li>• Do not operate the unit when fatigued or under the influence of drugs or alcohol.</li> <li>• Do not kink or over-bend the hose.</li> <li>• Do not expose the hose to temperatures or to pressures in excess of those specified by Graco.</li> <li>• Do not use the hose as a strength member to pull or lift the equipment.</li> </ul>
 	<p>Misuse of the sprayer platform can cause death or serious injury.</p> <ul style="list-style-type: none"> <li>• Do not exceed platform rating.</li> <li>• Make sure sprayer is on firm, level, non-slippery, secure foundation before accessing sprayer platform.</li> <li>• Make sure platform has been properly secured to frame before standing on the platform.</li> <li>• If you are unable to step up to sprayer platform, use a stable intermediate stepping device for stepping up to sprayer platform or stepping down from sprayer platform.</li> <li>• Keep both feet squarely and firmly on platform.</li> <li>• Do not allow sprayer frame to come in contact with live electrical wires.</li> <li>• Do not over reach while on sprayer platform.</li> <li>• Do not position sprayer behind any doors when on sprayer platform.</li> </ul>
 	<p><b>ELECTRIC SHOCK HAZARD</b></p> <p>Improper grounding, setup, or usage of the system can cause electric shock.</p> <ul style="list-style-type: none"> <li>• Turn off and disconnect power cord before servicing equipment.</li> <li>• Use only grounded electrical outlets.</li> <li>• Use only 3-wire extension cords.</li> <li>• Ensure ground prongs are intact on sprayer and extension cords.</li> <li>• Do not expose to rain. Store indoors.</li> </ul>
	<p><b>PRESSURIZED ALUMINUM PARTS HAZARD</b></p> <p>Do not use 1, 1, 1-trichloroethane, methylene chloride, other halogenated hydrocarbon solvents or fluids containing such solvents in pressurized aluminum equipment. Such use can cause serious chemical reaction and equipment rupture, and result in death, serious injury, and property damage.</p>
	<p><b>BURN HAZARD</b></p> <p>Equipment surfaces can become very hot during operation. To avoid severe burns, do not touch hot equipment. Wait until equipment has cooled completely.</p>
	<p><b>MOVING PARTS HAZARD</b></p> <p>Moving parts can pinch or amputate fingers and other body parts.</p> <ul style="list-style-type: none"> <li>• Keep clear of moving parts.</li> <li>• Do not operate equipment with protective guards or covers removed.</li> <li>• Pressurized equipment can start without warning. Before checking, moving, or servicing equipment, follow the <b>Pressure Relief Procedure</b> in this manual. Disconnect power or air supply.</li> </ul>
	<p><b>TOXIC FLUID OR FUMES HAZARD</b></p> <p>Toxic fluids or fumes can cause serious injury or death if splashed in the eyes or on skin, inhaled, or swallowed.</p> <ul style="list-style-type: none"> <li>• Read MSDS's to know the specific hazards of the fluids you are using.</li> <li>• Store hazardous fluid in approved containers, and dispose of it according to applicable guidelines.</li> </ul>
	<p><b>PERSONAL PROTECTIVE EQUIPMENT</b></p> <p>You must wear appropriate protective equipment when operating, servicing, or when in the operating area of the equipment to help protect you from serious injury, including eye injury, inhalation of toxic fumes, burns, and hearing loss. This equipment includes but is not limited to:</p> <ul style="list-style-type: none"> <li>• Protective eye wear</li> <li>• Clothing and respirator as recommended by the fluid and solvent manufacturer</li> <li>• Gloves</li> <li>• Hearing protection</li> </ul>

# Component Identification

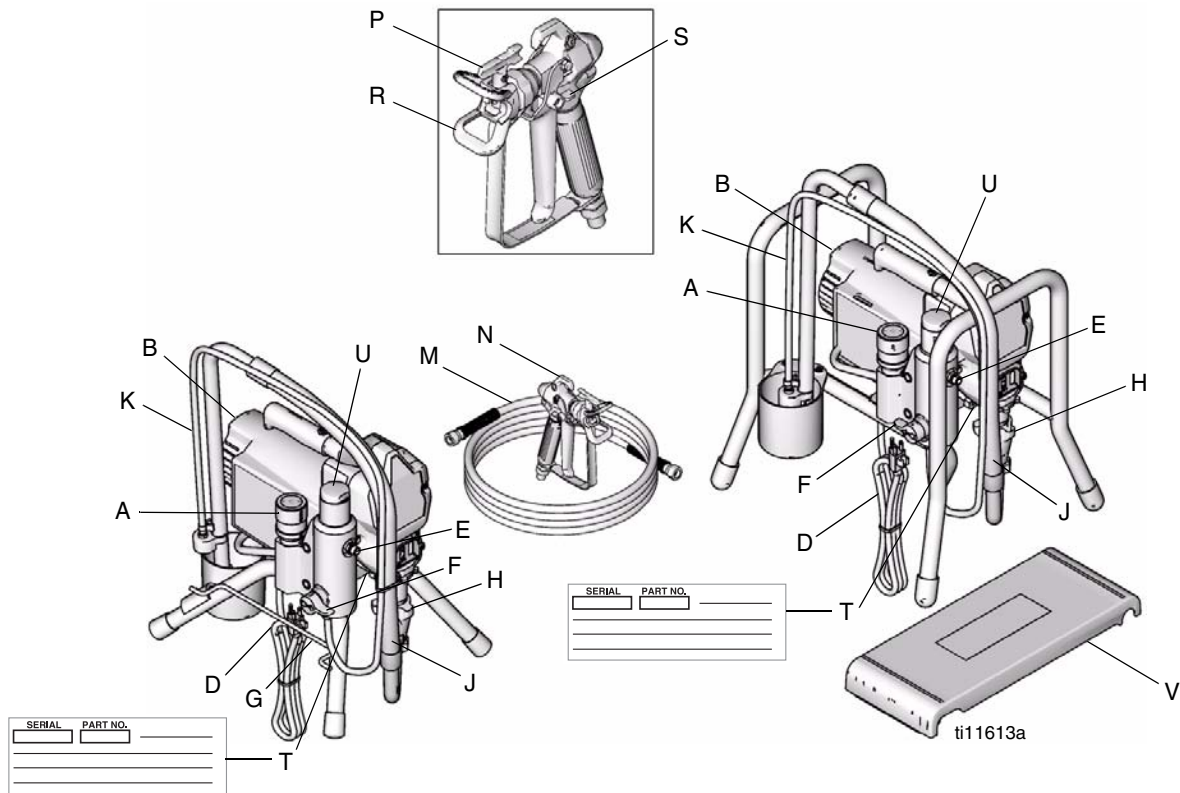

Item	Component
A	Pressure Control
B	ON/OFF switch
D	Power Cord
E	Fluid Outlet
F	Prime Valve
G	Cord Wrap
H	Pump
J	Suction Hose
K	Drain Hose
M	Fluid Hose
N	Gun
P	Tip
R	Guard
S	Trigger Safety Lock
T	Serial Number ID Label
U	Filter Cover
V	Platform (826098 Only)

# Installation

## Grounding and Electric Requirements

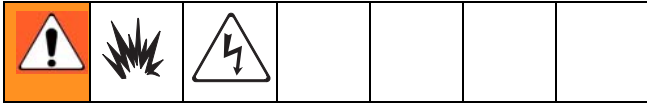

The sprayer cord includes a grounding wire with an appropriate grounding contact.

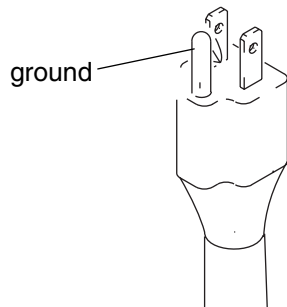

**The sprayer requires:**

110-120V Units: 100-130VAC, 50/60 Hz, 11A, 1 phase, circuit with a grounding receptacle.

**Never use an outlet that is not grounded or an adapter.**

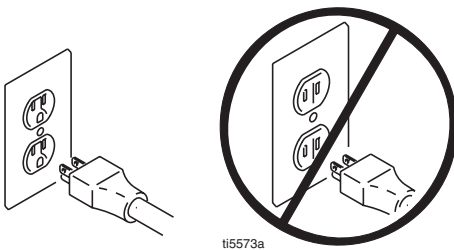

ti5573a

Do not use the sprayer if the electrical cord has a damaged ground contact. Only use an extension cord with an undamaged ground contact.

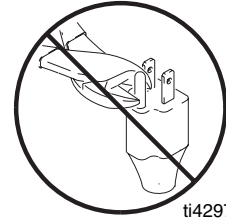

ti4297

**Recommended extension cords** for use with this sprayer:

- 110-120V: 3-wire, 12 AWG (2.5 mm<sup>2</sup>) minimum, 300 ft. (90 m) maximum length.

 Smaller gauge or longer extension cords may reduce sprayer performance.

**Spray gun:** ground through connection to a properly grounded fluid hose and pump.

**Fluid supply container:** follow local code.

**Solvent and Oil-based fluids:** follow local code. Use only conductive metal pails placed on a grounded surface such as concrete. Do not place the pail on a non-conductive surface such as paper or cardboard, which interrupts grounding continuity.

**Grounding the metal pail:** connect a ground wire to the pail by clamping one end to pail and other end to ground such as a water pipe.

**To maintain grounding continuity when flushing or relieving pressure:** hold metal part of the spray gun firmly to the side of a grounded metal pail, then trigger the gun.

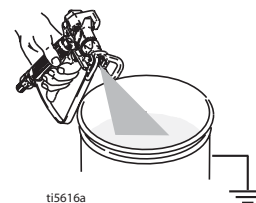

ti5616a

# Pressure Relief Procedure



Follow this **Pressure Relief Procedure** whenever you are instructed to relieve pressure, stop spraying, check or service equipment or install or clean spray tip.

1. Turn OFF power and turn pressure control to lowest pressure setting.
2. Hold gun against side of grounded metal flushing pail. Trigger gun to relieve pressure.

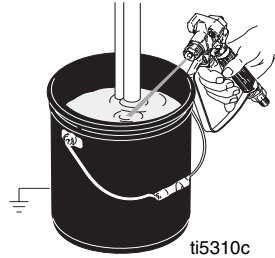

3. Turn prime valve down.

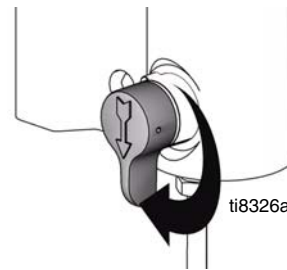

*If you suspect the spray tip or hose is clogged or that pressure has not been fully relieved after following the steps above, VERY SLOWLY loosen tip guard retaining nut or hose end coupling to relieve pressure gradually, then loosen completely. Clear hose or tip obstruction.*

4. Engage trigger safety lock on gun if unit is being shut down or left unattended.



# General Repair Information

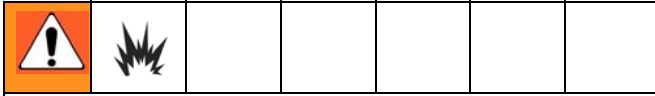
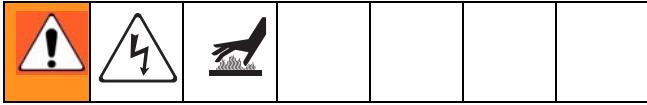

Flammable materials spilled on hot, bare, motor could cause fire or explosion. To reduce risk of burns, fire or explosion, do not operate sprayer with cover removed.

- Keep all screws, nuts, washers, gaskets, and electrical fittings removed during repair procedures. These parts usually are not provided with replacement kits.
- Test repairs after problems are corrected.
- If sprayer does not operate properly, review repair procedure to verify you did it correctly. See **Troubleshooting**, page 9.
- Overspray may build up in the air passages. Remove any overspray and residue from air passages and openings in the enclosures whenever you service sprayer.
- Do not operate the sprayer without the motor shroud in place. Replace if damaged. Motor shroud directs cooling air around motor to prevent overheating and insulate the control board from accidental electric shock.

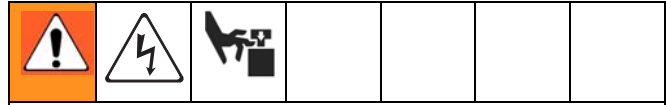

To reduce risk of serious injury, including electric shock:

- Do not touch moving or electric parts with fingers or tools while testing repair.
- Unplug sprayer when power is not required for testing.
- Install all covers, gaskets, screws and washers before you operate sprayer.

## CAUTION

- Do not run sprayer dry for more than 30 seconds. Doing so could damage pump packings.
- Protect the internal drive parts of this sprayer from water. Openings in the cover allow for air cooling of the mechanical parts and electronics inside. If water gets in these openings, the sprayer could malfunction or be permanently damaged.
- Prevent pump corrosion and damage from freezing. Never leave water or water-base paint in sprayer when its not in use in cold weather. Freezing fluids can seriously damage sprayer. Store sprayer with Pump Armor to protect sprayer during storage.



# Troubleshooting



Problem	What To Check <i>(If check is OK, go to next check)</i>	What To Do <i>(When check is not OK, refer to this column)</i>
<b>Motor Won't Operate</b>		
Basic Fluid Pressure	1. Pressure control knob setting. Motor will not run if set at minimum (fully counter-clockwise).	Slowly increase pressure setting to see if motor starts.
	2. Spray tip or fluid filter may be clogged.	<b>Relieve pressure</b> , page 7. Then clear clog or clean gun filter. Refer to gun instruction manual, 309639.
Basic Mechanical	1. Pump frozen or hardened paint	Thaw sprayer if water or water-based paint has frozen in sprayer. Place sprayer in warm area to thaw. Do not start sprayer until thawed completely. If paint hardened (dried) in sprayer, replace pump packings. See page 13, <b>Displacement Pump Replacement</b> .
	2. Displacement pump connecting rod pin. Pin must be completely pushed into connecting rod and retaining spring must be firmly in groove or pump pin.	Push pin into place and secure with spring retainer. See page 13, <b>Displacement Pump Replacement</b> .
	3. Motor. Remove drive housing assembly. See page 15, <b>Drive Housing Replacement</b> . Try to rotate fan by hand.	Replace motor if fan won't turn. See page 26, <b>Motor Replacement</b> .

<p><b>Problem</b></p>	<p><b>What To Check</b> <i>(If check is OK, go to next check)</i></p>	<p><b>What To Do</b> <i>(When check is not OK, refer to this column)</i></p>
<p>Basic Electrical <i>See wiring diagram, page 29</i></p>	<p>1. Electric supply. Meter must read 100-130 VAC for 110-120 VAC models.</p>	<p>Reset building circuit breaker, replace building fuses. Try another outlet.</p>
	<p>2. Extension cord. Check extension cord continuity with volt meter.</p>	<p>Replace extension cord.</p>
	<p>3. Sprayer power supply cord. Inspect for damage such as broken insulation or wires.</p>	<p>Replace power supply cord. See page 25, <b>Power Cord Replacement.</b></p>
	<p>4. Fuse. Check replaceable fuse on control board (next to ON/OFF switch).</p>	<p>Replace fuse after completing motor inspection. See page 21, <b>Fuse Replacement.</b></p>
	<p>5. Motor leads are securely fastened and properly connected to control board.</p>	<p>Replace loose terminals; crimp to leads. Be sure terminals are firmly connected.  Clean circuit board terminals. Securely reconnect leads.</p>
	<p>6. Motor thermal switch. Yellow motor leads must have continuity through thermal switch.</p>	<p>Replace motor. See page 26, <b>Motor Replacement.</b></p>
	<p>7. Brush cap missing or loose brush lead connections.</p>	<p>Install brush cap or replace brushes if leads are damaged. See page 18, <b>Motor Brush Replacement.</b></p>
	<p>8. Brush length which must be 1/4 in. (6mm) minimum.  NOTE: Brushes do not wear at the same rate on both sides of motor. Check both brushes.</p>	<p>Replace brushes. See page 18, <b>Motor Brush Replacement.</b></p>
	<p>9. Motor armature commutator for burn spots, gouges and extreme roughness.</p>	<p>Remove motor and have motor shop resurface commutator if possible. See page 26, <b>Motor Replacement.</b></p>
	<p>10. Motor armature for shorts using armature tester (growler) or perform spin test, page 16.</p>	<p>Replace motor. See page 26, <b>Motor Replacement.</b></p>
	<p>11. Pressure control not plugged in to control board.</p>	<p>Insert pressure control connector into control board.</p>

<b>Problem</b>	<b>What To Check</b> <i>(If check is OK, go to next check)</i>	<b>What To Do</b> <i>(When check is not OK, refer to this column)</i>
Low Output	1. Worn spray tip.	<b>Relieve pressure</b> , page 7. Replace tip. Refer to gun instruction manual, 309639.
	2. Verify pump does not continue to stroke when gun trigger is released.	Service pump. See page 13, <b>Displacement Pump Replacement</b> .
	3. Prime valve leaking.	<b>Relieve pressure</b> , page 7. Then repair prime valve. See page 23, <b>Manifold Replacement</b> .
	4. Suction hose connections.	Tighten any loose connections. Check o-rings on suction hose swivel.
	5. Electric supply with volt meter. Meter must read 100-130 VAC for 110-120 VAC models. Low volt-ages reduce sprayer perfor-mance.	Reset building circuit breaker; replace building fuse. Repair electrical outlet or try another outlet.
	6. Extension cord size and length.	7. Replace with a correct, grounded extension cord. See page 6, <b>Grounding and Electric Requirements</b> .
	8. Leads from motor to circuit board for damaged or loose wire con-nectors. Inspect wiring insulation and terminals for signs of over-heating.	Be sure male terminal pins are centered and firmly connected to female terminals. Replace any loose terminals or damaged wiring. Securely reconnect terminals.
	9. Worn motor brushes which must be 1/4 in. (6 mm) minimum.	Replace brushes. See page 18. <b>Motor Brush Replacement</b> .
	10. Motor brushes binding in brush holders.	Clean brush holders. Remove carbon dust by using compressed air to blow out brush dust.
	11. Low stall pressure. Turn pressure control knob fully clockwise.	Replace pressure control assembly. See page 22, <b>Pressure Control Assembly Replace-ment</b> .
	12. Motor armature for shorts by using an armature tester (growler) or perform spin test, page 16.	Replace motor. See page 26, <b>Motor Replacement</b> .

<p><b>Problem</b></p>	<p><b>What To Check</b> <i>(If check is OK, go to next check)</i></p>	<p><b>What To Do</b> <i>(When check is not OK, refer to this column)</i></p>
<p>Motor runs and pump strokes</p>	<p>1. Prime Valve Open.</p>	<p>Close prime valve.</p>
	<p>2. Paint supply.</p>	<p>Refill and reprime pump.</p>
	<p>3. Intake strainer clogged.</p>	<p>Remove and clean, then reinstall.</p>
	<p>4. Suction hose leaking air.</p>	<p>Tighten nut. Check o-rings on swivel.</p>
	<p>5. Intake valve ball and piston ball are seating properly.</p>	<p>See Pump Manual 309250. Strain paint before using to remove particles that could clog pump.</p>
	<p>6. Leaking around throat packing nut which may indicate worn or damaged packings.</p>	<p>See Pump Manual 309250.</p>
	<p>7. Pump rod damaged.</p>	<p>See Pump Manual 309250.</p>
<p>Motor runs but pump does not stroke</p>	<p>1. Displacement pump pin damaged or missing.</p>	<p>Replace pump pin if missing. Be sure retaining spring is fully in groove all around connecting rod. See page 13, <b>Displacement Pump Replacement</b>.</p>
	<p>2. Connecting rod assembly for damage.</p>	<p>Replace connecting rod assembly. See page 13, <b>Displacement Pump Replacement</b>.</p>
	<p>3. Gears or drive housing.</p>	<p>Inspect drive housing assembly and gears for damage and replace if necessary. See page 15, <b>Drive Housing Replacement</b>.</p>
<p>Motor is hot and runs intermittently</p>	<p>1. Be sure ambient temperature where sprayer is located is not more than 115°F (46°C) and sprayer is not located in direct sun.</p>	<p>Move sprayer to shaded, cooler area if possible.</p>
	<p>2. Motor has burned windings indicated by removing positive (red) brush and seeing burned adjacent commutator bars.</p>	<p>Replace motor. See page 26, <b>Motor Replacement</b>.</p>
	<p>3. Tightness of pump packing nut. Overtightening tightens packings on rod, restricts pump action and damages packings.</p>	<p>Loosen packing nut. Check for leaking around throat. Replace pump packings if necessary. See pump manual 309250.</p>

# Displacement Pump Replacement

See manual 309250 for pump repair instructions.

## Removal



1. **Relieve pressure**, page 7. Unplug sprayer from outlet.
2. Loosen two screws (30) and rotate cover (44).

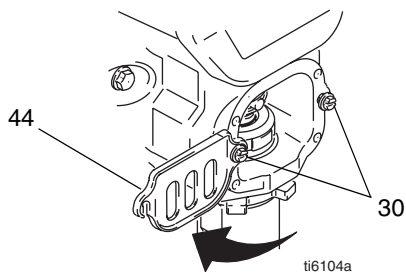

3. Loosen nut (A) and remove suction hose (35). Loosen nut (B) and remove the high pressure hose (14).

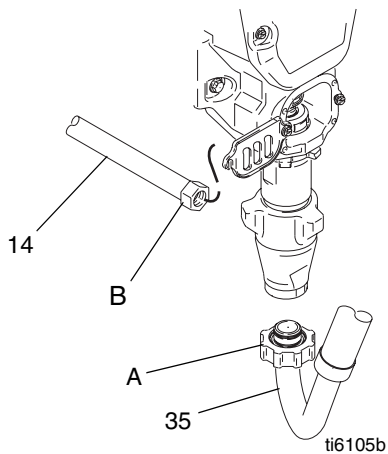

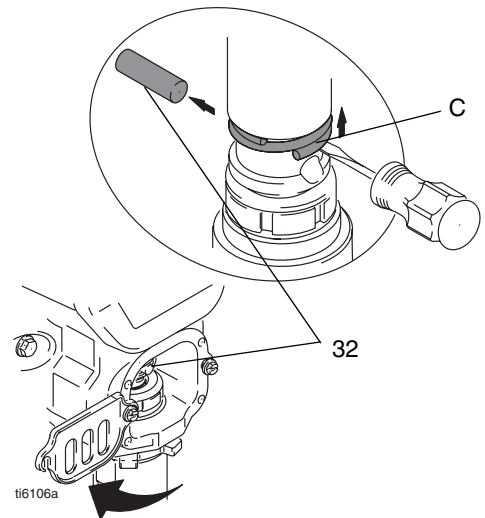

4. Cycle pump until pin (32) is in position to be removed.
5. Disconnect power cord from outlet.
6. Using a flat screwdriver, push retaining spring (C) up. Push out pump pin (32).

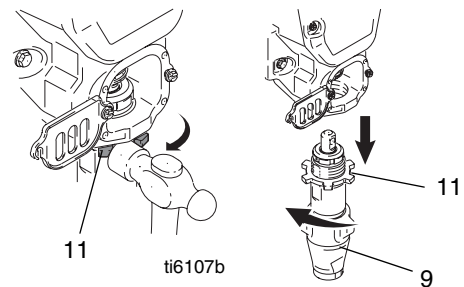

7. Using a hammer, loosen pump jam nut (11). Unscrew and remove pump (9).



## Installation

						
<p>If pump pin works loose, parts could break off due to force of pumping action. Parts could project through air and result in serious injury or property damage.</p>						

<b>CAUTION</b>
<p>If the pump jam nut loosens during operation, the threads of the drive housing will be damaged.</p>

1. Extend pump piston rod full. Apply grease to top of pump rod at (D) or inside connecting rod (7). Install jam nut (11) on pump threads.

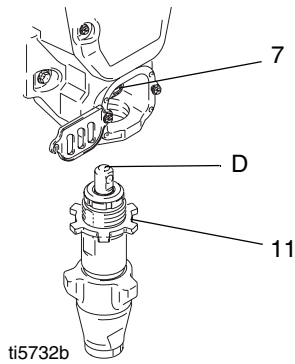

2. Install pump rod (D) into connecting rod (7).
3. Install pump pin (32). Verify retainer spring (C) is in groove over pump pin.

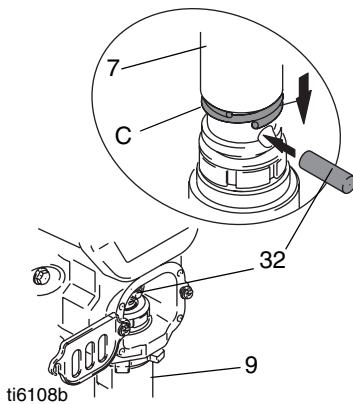

4. Push pump (9) up until pump threads engage.

5. Screw in pump until threads are flush with top of drive housing opening.

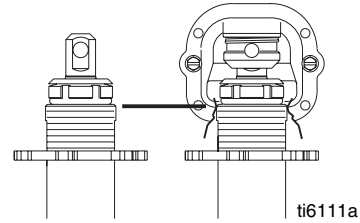

6. Align pump outlet (E) to back.

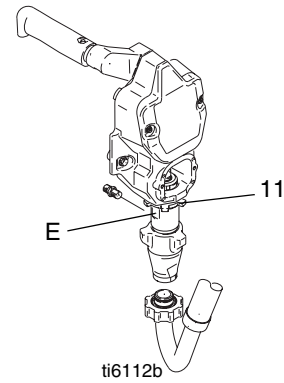

7. Screw jam nut (11) up onto pump until nut stops. Tighten jam nut by hand, then tap 1/8 to 1/4 turn with a 20 oz (maximum) hammer to approximately 75 ft-lb (102 N•m).
8. Install suction tube (35) and high pressure hose (14). Tighten nuts (A) and (B).

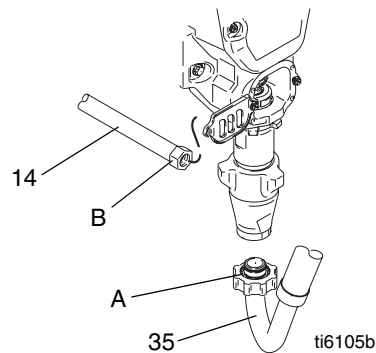

9. Fill packing nut with Graco TSL until fluid flows onto top of seal. Rotate cover (44). Tighten screws (30).

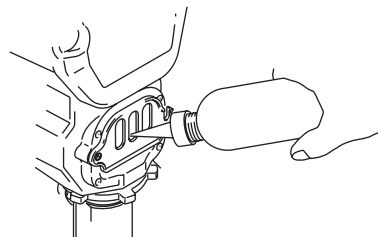

# Drive Housing Replacement



## Removal

1. **Relieve pressure**, page 7.
2. Remove pump (9). **Displacement Pump Replacement**, page 13.
3. Disconnect power cord from outlet.

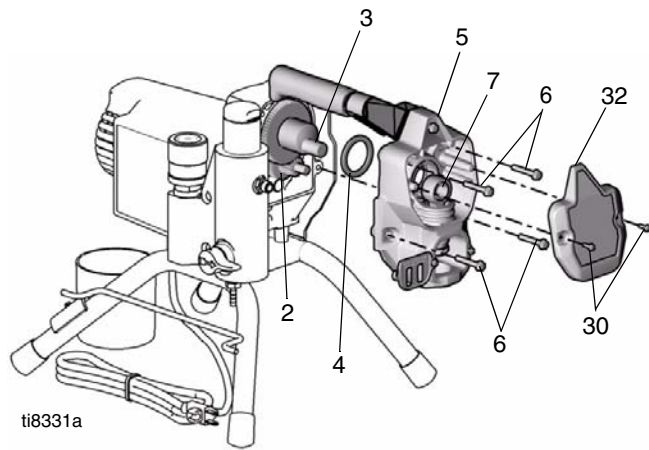

4. Remove two screws (30) and cover (32).
5. Remove four screws (6).
6. Pull drive housing (5) out of motor front endbell.
7. Remove gear cluster (2) and (3) and thrust bearing (4) from drive housing.

### CAUTION

Do not drop gear cluster (3) and (2) when removing drive housing (5). Gear cluster may stay engaged in motor front endbell or drive housing.

## Installation

1. Apply a liberal coat of grease to gears and needle bearing surfaces. Install thrust bearing (4) and gears (2) and (3) in front endbell housing.

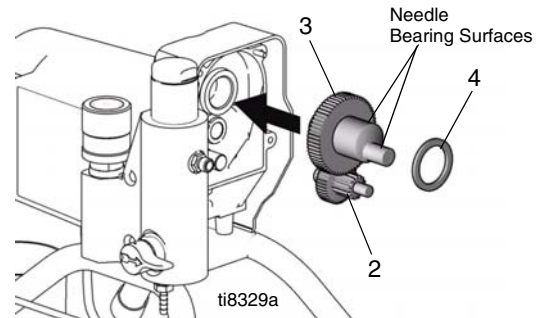

2. Push drive housing into front endbell housing. Insert gear crank (3) through hole in connecting rod (7).

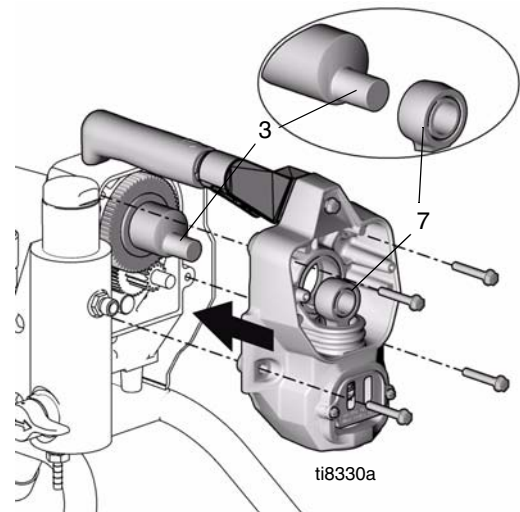

3. Install four screws (6).
4. Install cover (32) with two screws (30).
5. Install pump (9). **Displacement Pump Replacement**, page 13.



# Spin Test

See *Wiring Diagram*, page 29.

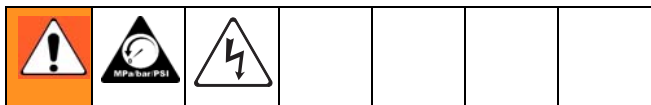

To check armature, motor winding and brush electrical continuity:

1. **Relieve pressure**, page 7. Disconnect power cord from outlet.
2. Remove two screws (30) and shroud (29).
3. Remove drive housing (5), page 15.
4. Disconnect motor connector (F).

## Armature Short Circuit Test

Quickly turn motor fan by hand. If motor coasts two or three revolutions before complete stop, there are no electrical shorts. If motor does not spin freely, armature is shorted. Replace motor, page 26.

## Armature, Brushes, and Motor Wiring Open Circuit Test (Continuity)

1. Connect red and black motor leads with test lead. Turn motor fan by hand at about two revolutions per second.

2. If uneven or no resistance, check for missing brush caps, broken brush springs, brush leads, and worn brushes. Repair as needed, page 18.
3. If still uneven or no resistance, replace motor, page 26.

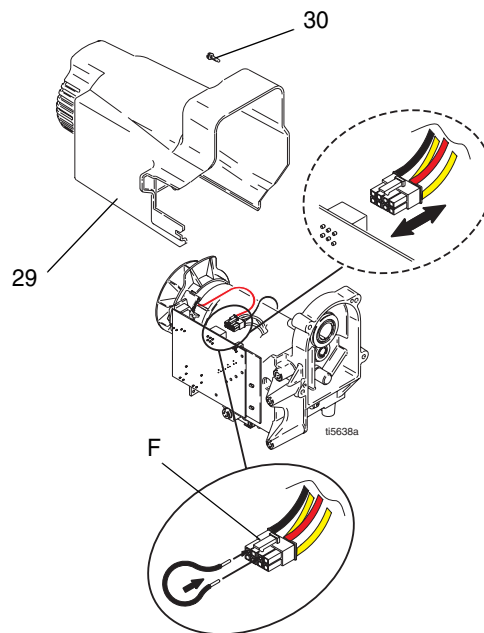

4. Reattach motor connector (F).
5. Replace drive housing, page 15.
6. Replace shroud (29) and two screws (30).

# Fan Replacement

## Removal

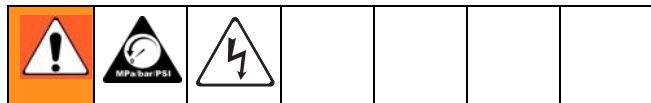

1. **Relieve pressure**, page 7. Disconnect power cord from outlet.
2. Remove two screws (30) and shroud (29).
3. Remove spring clip (1b) on back of motor.
4. Pull off fan (100).

## Installation

1. Slide new fan (1a) in place on back of motor. Be sure blades of fan face motor as shown.
2. Install spring clip (1b).
3. Replace shroud (29) and two screws (30).

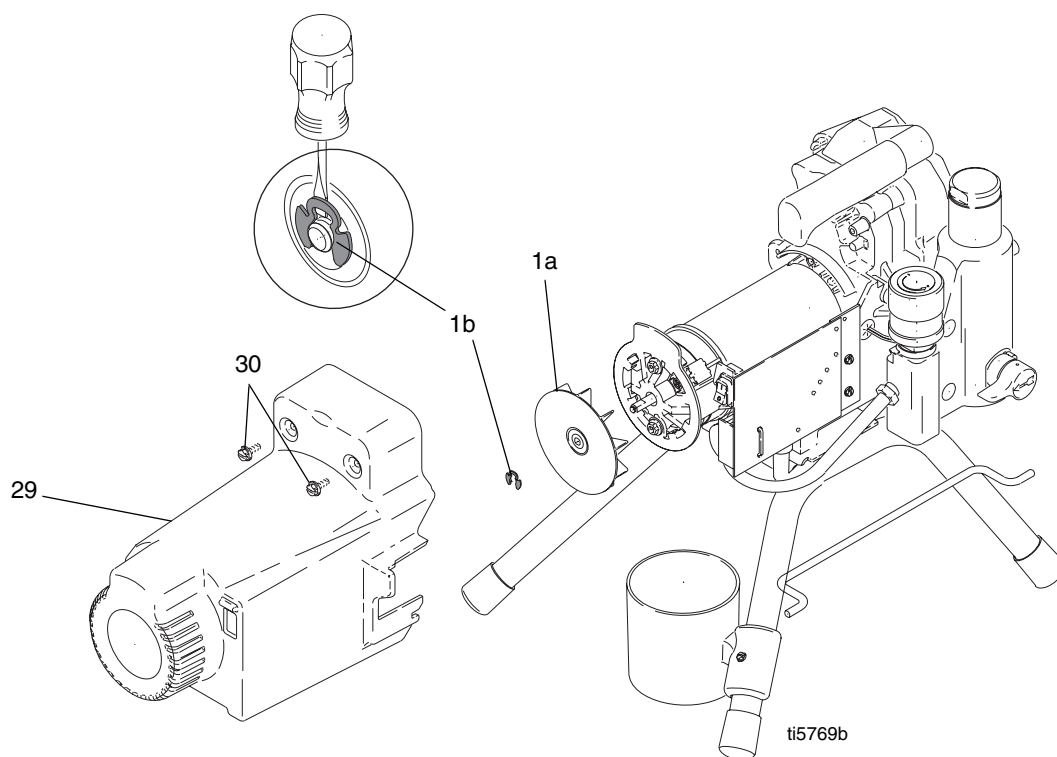

# Motor Brush Replacement

See *Wiring Diagram*, page 29.

## Removal

Replace brushes worn to less than 1/4 in. (6mm). Brushes wear differently on each side of motor, check both sides.

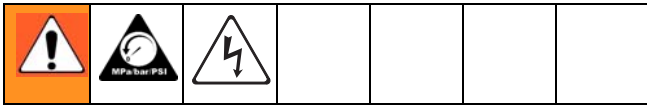

1. **Relieve pressure**, page 7. Disconnect power cord from outlet.
2. Remove two screws (30) and shroud (29) (see illustration on page 16).
3. Disconnect motor connector (D) from control board (33).
4. Cut tie wrap (F).
5. Locate two yellow wires (C) (thermal leads). Cut each yellow wire at the center.
6. Using a flat screwdriver, pry off (two) brush caps (A). Remove brushes (B) from motor.
7. Discard old brush harness.
8. While rotating fan by hand, using compressed air, blow air into positive (top) brush holder to remove brush dust.

 To contain the dust, turn on your shop vac. Place the end of the hose over the negative (lower) brush holder while blowing compressed air into the positive (top) brush holder.

## Installation

 Use all new parts included in your brush kit. Do not reuse old parts if new replacement parts are provided.

1. With wires facing toward front of motor, install new brushes (B) in motor. Be sure to install the positive (red) brush lead in the top of the motor (as shown) and the negative (black) brush lead in the side of the motor.

2. Push each cap (A) into place over brush. Orient each cap with the 2 projections on either side of the brush lead. You will hear a “snap” when cap is securely in place.
3. Using a wire stripper, strip off wire insulation approximately 1/4 inch (6 mm) from the end of each yellow wire (C) to the motor.
4. Insert stripped end into end of a butt splice (E) on new brush assembly.
5. Use a crimping tool to squeeze the ends of the butt splice (E) tightly around each wire. Pull gently on each wire to be sure it will not pull out of the butt splice.
6. Using new tie wrap (F) from kit, wrap tie around motor and wires only. Trim off excess. Be sure pressure hose and wire leads are not caught in tie wrap.
7. Reconnect motor connector (D) to control board (33).

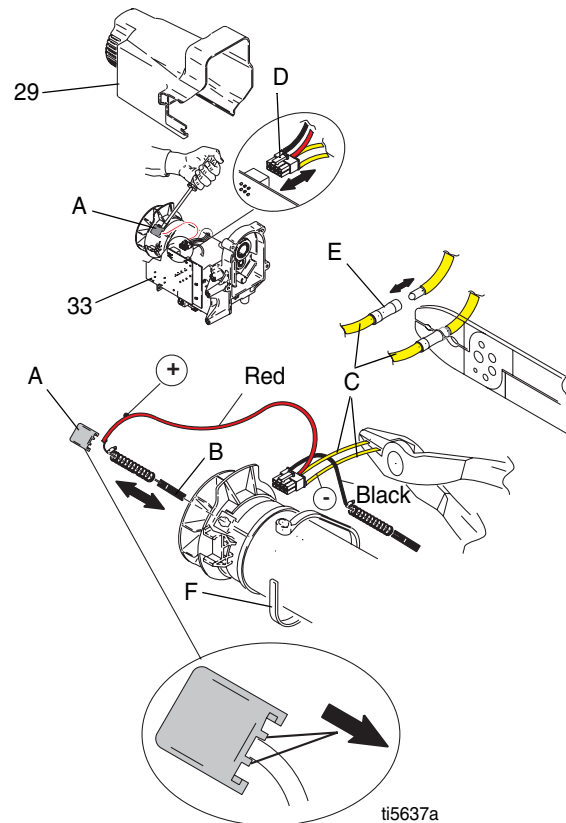

8. Replace shroud (29) and two screws (30) (see illustration, page 16).

# Control Board Replacement

See Wiring Diagram, page 29.



## Removal

1. **Relieve pressure**, page 7. Disconnect power cord from outlet.
2. Remove two screws (30) and shroud (29) (see illustration, page 16).
3. Disconnect pressure switch connector (A) from control board (33).

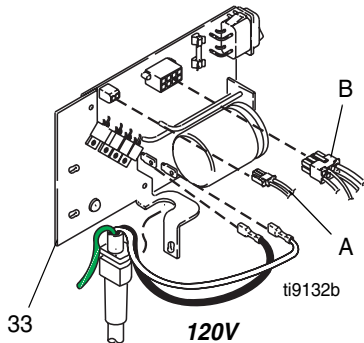

4. Disconnect motor connector (B) from control board (33).
5. Remove 3 screws (30) securing control board to housing (2 are located on the front and one on the back next to the power cord).

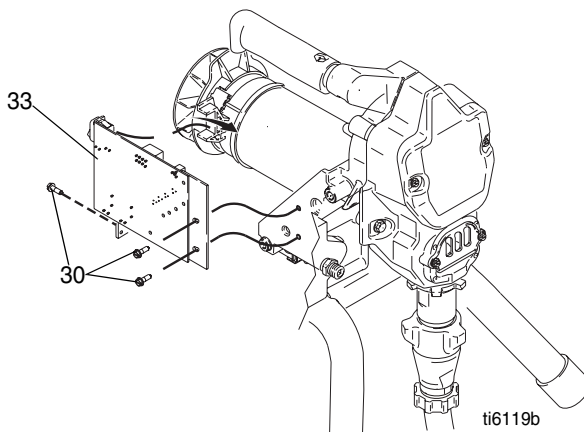

6. Pull control board out slightly and then slide it back and off of frame.

 Make sure power cord is free and NOT wrapped around cord wrap.

7. Remove grommet and wires from strain relief.

 Ground wire will remain attached to sprayer with grounding screw.

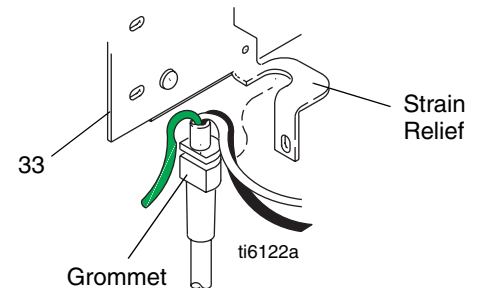

8. Remove 2 power cord (C) connectors from control board.

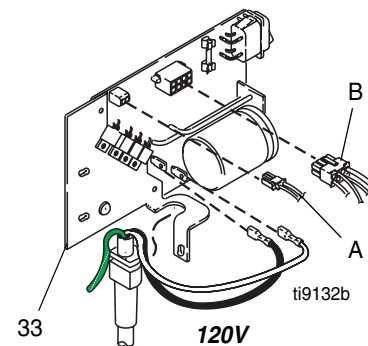

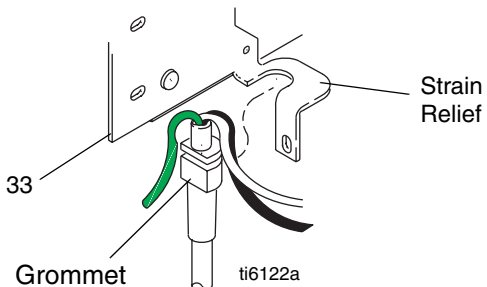

## Installation

1. Position grommet and power cord wires through strain relief in control board (33).

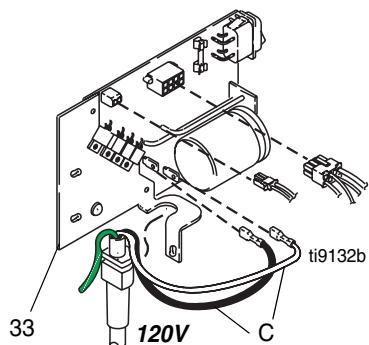

2. Reconnect the power cord connectors to the correct terminals indicated on the control board (120V, black and white) on control board (33).



 Be sure power cord is routed between the blue high pressure hose to the manifold and the sprayer frame.

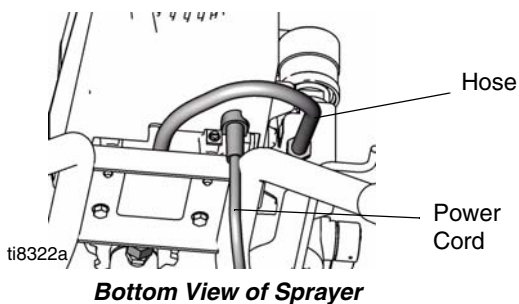

3. Carefully slide control board back into place on the side of the motor frame.

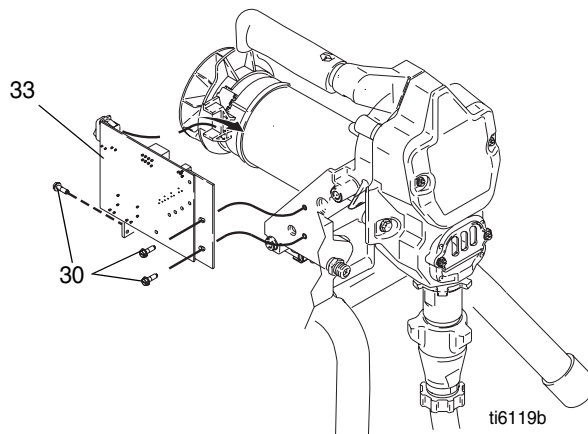

4. Replace 3 screws (30). Torque to 30-35 in-lbs (3.4-3.9 N.m).

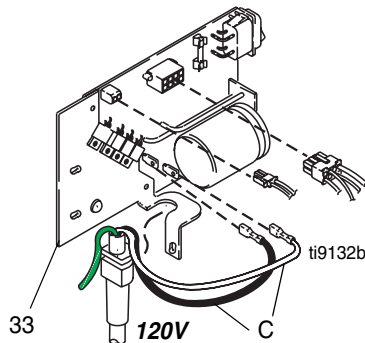

5. Reattach motor connector (B) and pressure control assembly connector (A).
6. Install shroud (29) and two screws (30) (see illustration, page 16).

# Fuse Replacement

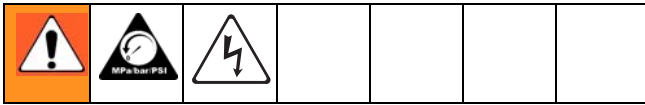

## Removal

1. **Relieve pressure**, page 7. Disconnect power cord from outlet.
2. Remove two screws (30) and shroud (29) (see illustration, page 16).
3. Remove fuse from control board.

## Installation

1. Install new fuse on control board.
2. Install shroud (29) and two screws (30) (see illustration, page 16).

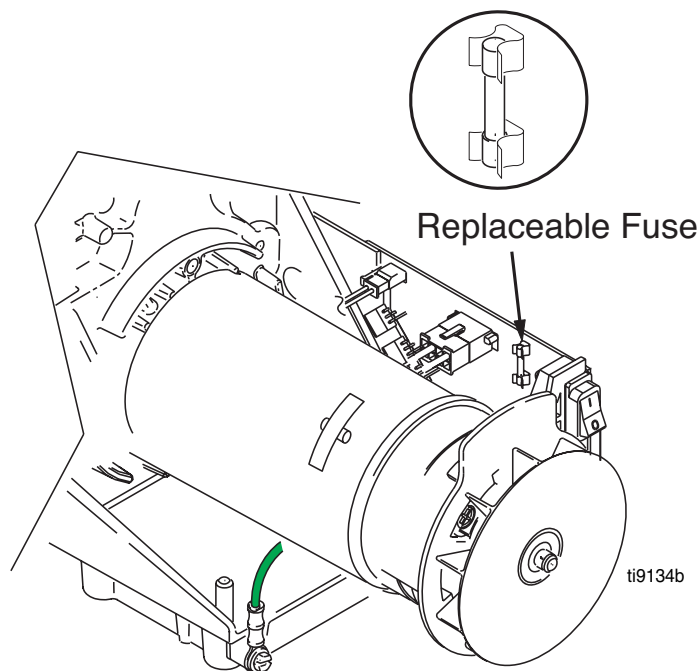

# Pressure Control Assembly Replacement

See *Wiring Diagram*, page 29.

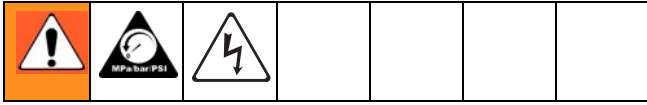

## Removal

1. **Relieve pressure**, page 7. Disconnect power cord from outlet.
2. Remove two screws (30) and shroud (29) (see illustration, page 16).
3. Disconnect pressure switch connector (A) from control board (33).
4. Remove tape (22) holding wires to manifold.
5. Pull wires back through hole (K) in housing.

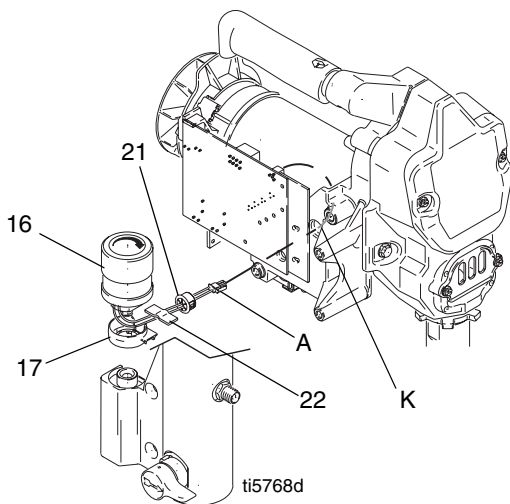

## Installation

Inspect pressure control assembly before installation to verify the o-ring is installed and in place.

1. Align grommet collar (17) on fluid manifold so opening faces toward motor.
2. Apply Loctite® to pressure control assembly threads (16)
3. Screw pressure control assembly (16) into manifold and torque to 150 in-lbs (17.0 N.m)

6. Turn the pressure control knob (16) counter clockwise as far as you can to access the flats on either side of the pressure control assembly.
7. Using a 1 in. (26 mm) wrench loosen and unscrew pressure control assembly.

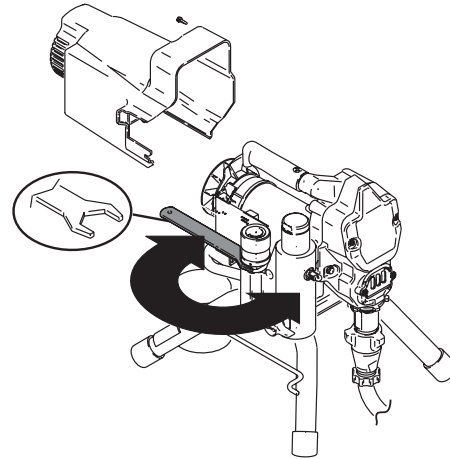

If you plan to reuse the pressure control assembly, be very careful not to damage or tangle the wires while unscrewing the assembly.

8. Remove pressure control assembly.

Be careful when tightening pressure control knob that wires do not get pinched between the pressure control assembly and fluid manifold.

4. Wrap wires around knob and feed through slot in grommet (21).
5. Insert grommet (21) in hole (K) in housing. Secure wires to manifold housing with tape (22).
6. Reconnect pressure switch connector (A) to control board (33).
7. Install shroud (29) and two screws (30) (see illustration, page 15).



# Drain Valve Replacement



## Removal

1. **Relieve pressure**, page 7. Disconnect power cord from outlet.
2. Using a punch and hammer, tap pin (26) out of drain handle (25).
3. Pull drain handle (25) and base (24) off drain valve (23).
4. Using a wrench, loosen drain valve (23) and remove it from manifold (15).

## Installation

 Before installing new drain valve, be sure old gasket (23a) and seat (23b) are not still inside manifold.

1. Thread drain valve (23) into manifold (15) opening.
2. Hand tighten securely. Using a wrench, torque to 120 to 130 in-lbs.
3. Push base (24) over drain valve (23) and then drain handle (25) over base (24).
4. Replace pin (26) in drain handle (25). If necessary, use a hammer to tap it in place completely.

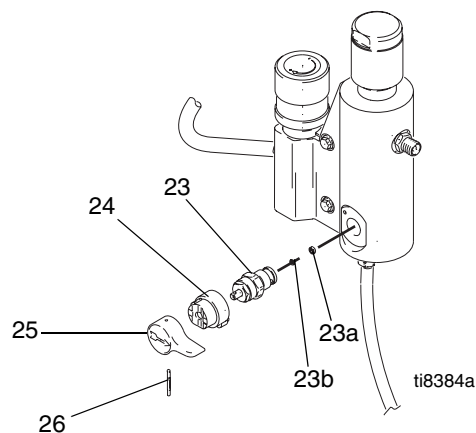

# Drain Line Removal/Replacement

## Removal

To remove the drain line (40) from the manifold:

1. Cut drain line (40) from barbed fitting (20).
2. Unscrew barbed fitting (20) from manifold.

 If you are only replacing the manifold and will be reusing the existing barbed fitting (20) and drain line (40), you will need to use a sharp knife to cut the remaining drain line material off the end of the barbed fitting (20).

## Installation

1. Screw barbed fitting (20) into manifold.
2. Push drain line (40) onto barbed fitting (20).

 To make the drain line more pliable and easier to install over barbed fitting, heat end of drain line (40) with a hair dryer or by placing end in hot water a few seconds.

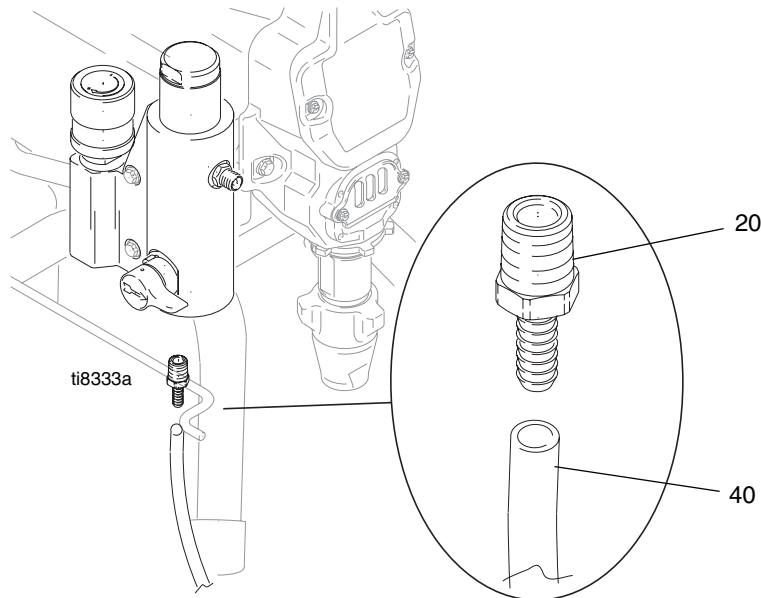

# Power Cord Replacement

See *Wiring Diagram*, page 29.

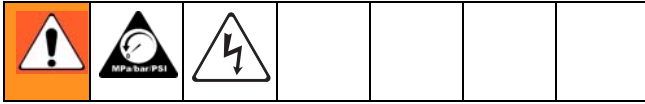

## Removal

1. Follow **Control Board Replacement** removal instructions, steps 1-8, page 19.
2. Disconnect power cord connectors (C and D) from control board (33).
3. Disconnect green ground wire (G) from sprayer by loosening grounding screw (31).

## Installation

1. Follow **Control Board Replacement** installation instructions, steps 1-4, page 19.
2. Reconnect, green ground wire (G) to green grounding screw (31) on frame. Be sure terminal on ground faces UP or wires could get caught in shroud.
3. Reconnect power cord connectors (C and D) to control board (33).
4. Reattach motor connector (B) and pressure control switch connect (A).
5. Install shroud (29) and two screws (30) (see illustration, page 16).

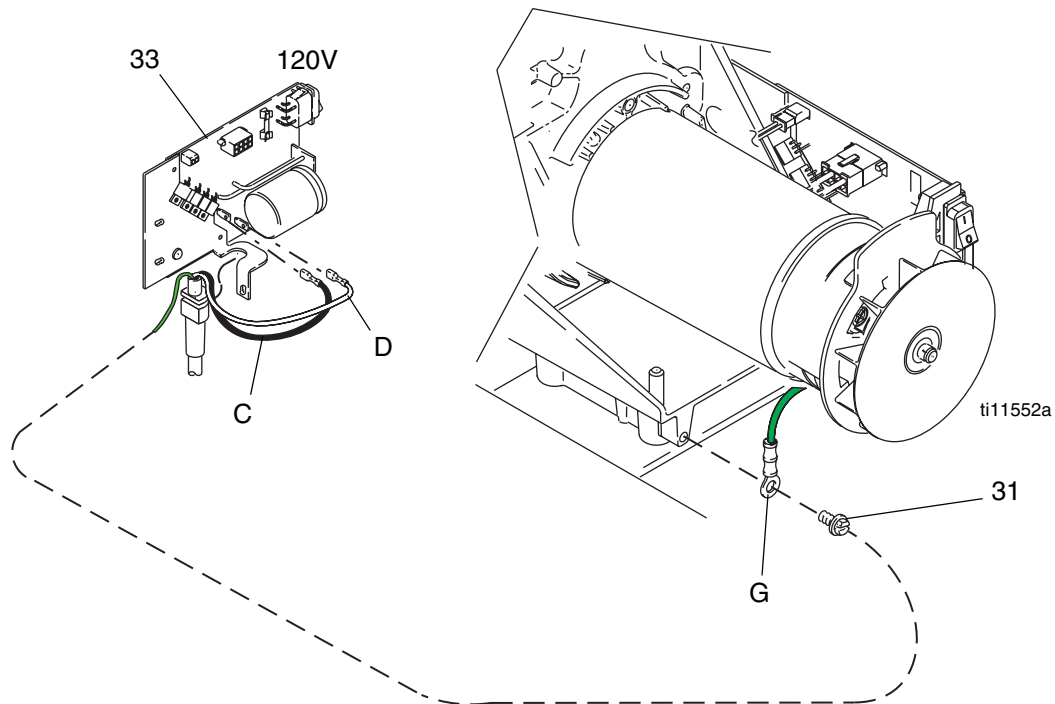

# Motor Replacement

See *Wiring Diagram*, page 29.

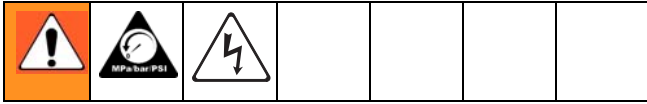

## CAUTION

Do not drop gear cluster (3) and (2) when removing drive housing (5). Gear cluster may stay engaged in motor frontend bell or drive housing.

## Removal

1. **Relieve pressure**, page 7. Disconnect power cord from outlet.
2. Remove pump (9). **Displacement Pump Replacement**, page 13.
3. Remove drive housing, **Drive Housing Replacement**, page 15.
4. Remove Pressure (Fluid) Manifold, **Manifold Replacement**, page 23.
5. Disconnect all leads from board (33) and remove control board. **Control Board Replacement**, page 19.

6. Remove ground wire (G) from motor endbell.
7. Remove four screws (6) and motor (1) from frame (45).

## Installation

1. Install new motor (1) on frame (45) with four screws (6).
2. Install manifold (15) with two screws (6). **Manifold Replacement**, page 23
3. Install control board (33) with three screws (30). Connect all leads to board. See **Control Board Replacement**, page 19 and **Wiring Diagram**, page 29.
4. Connect ground wire (G) to motor with green ground screw (31).
5. Install Drive Housing. **Drive Housing Replacement**, page 15.
6. Install pump (9). **Displacement Pump Replacement**, page 13.
7. Install shroud (29) with two screws (30) (see illustration, page 16).

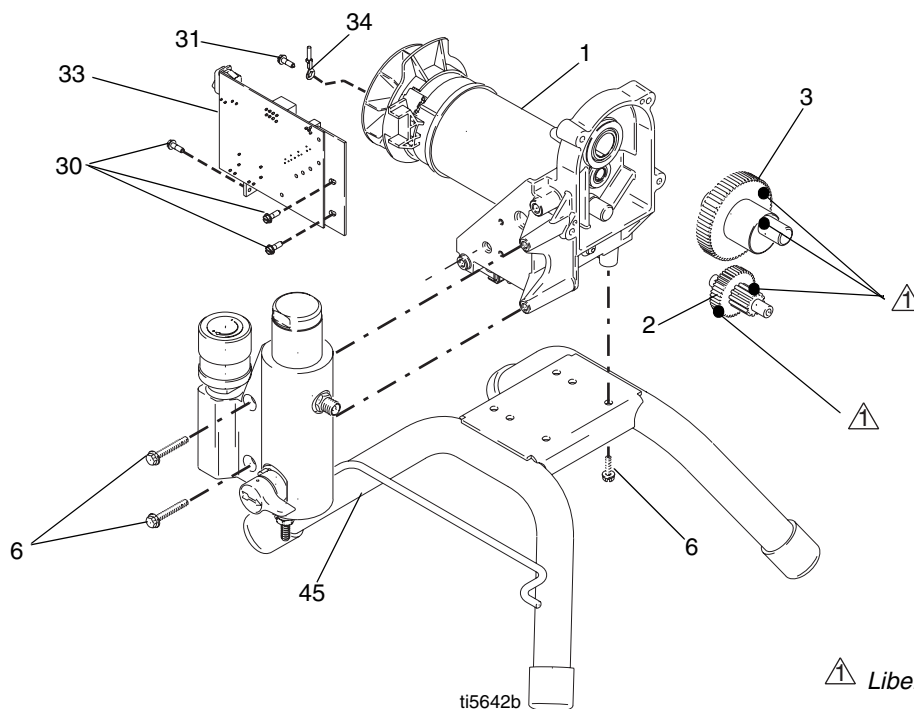

# Platform Access Position (826098 Only)



To avoid falling, make sure sprayer is on a firm, level, non-slippery, secure foundation before standing on sprayer platform.



To avoid electrocution, do not allow sprayer frame to come in contact with live electrical wires.



To avoid falling, do not over reach while standing on sprayer platform.

If you are unable to step up to sprayer platform, use a stable intermediate stepping device.

The sprayer platform is reversible, and can be installed facing either direction.

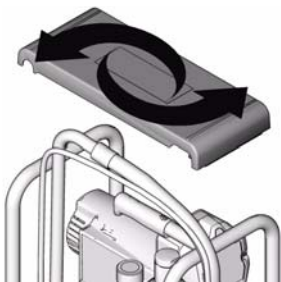

To install the platform, perform the following steps:

1. Slide platform guiding plate (G) into sprayer frame.

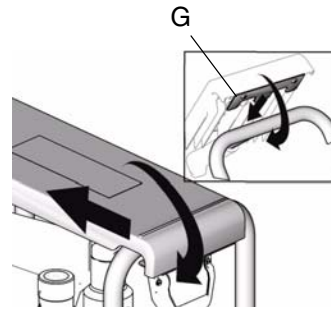

2. Align groove underneath platform with sprayer handle (H).

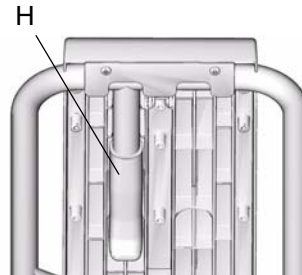

3. Press other end of platform down onto opposite end of sprayer frame. Make sure frame peg (P) is aligned with slot underneath platform.

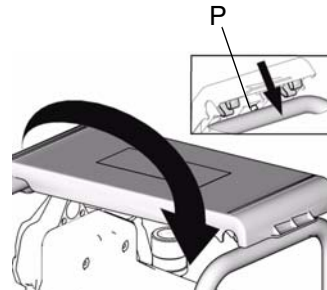

## CAUTION

If the frame peg (P) is not aligned with the slot underneath platform, the platform will not be fully resting on the sprayer frame and will be unsafe to stand on.

# Platform Transport Position (826098 Only)

Attach the sprayer platform to the side of the sprayer frame to access the handle and transport the prayer.

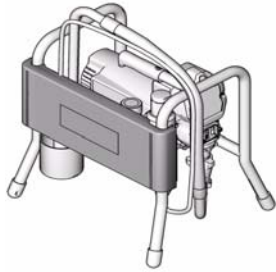

1. Lift platform off peg (P) side of sprayer frame.

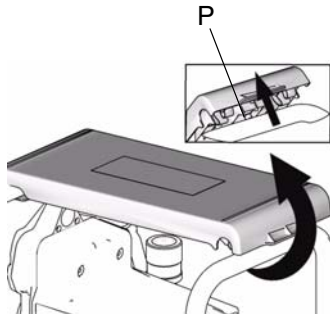

2. Slide guiding plate (G) off opposite side of frame and lift platform off of sprayer.

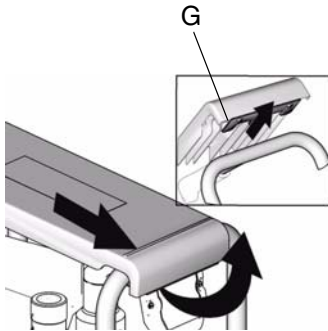

3. Slide guiding plate (G) onto either side of sprayer frame.

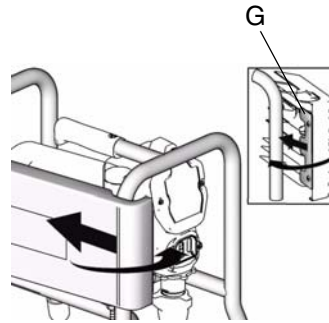

4. Align clips on opposite side of platform with sprayer frame and push until it snaps onto frame.

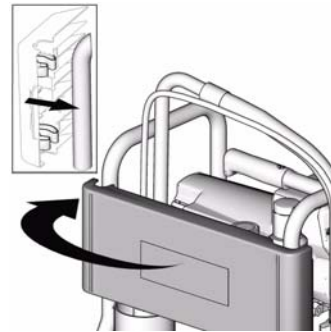

 NOTE: Platform is reversible and can be attached to either side of the sprayer frame.

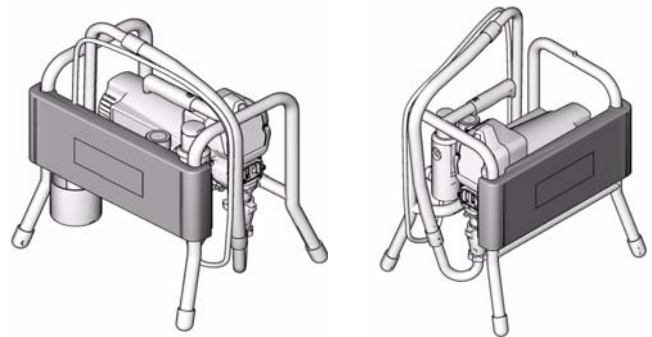

# Wiring Diagram

## 120V Model

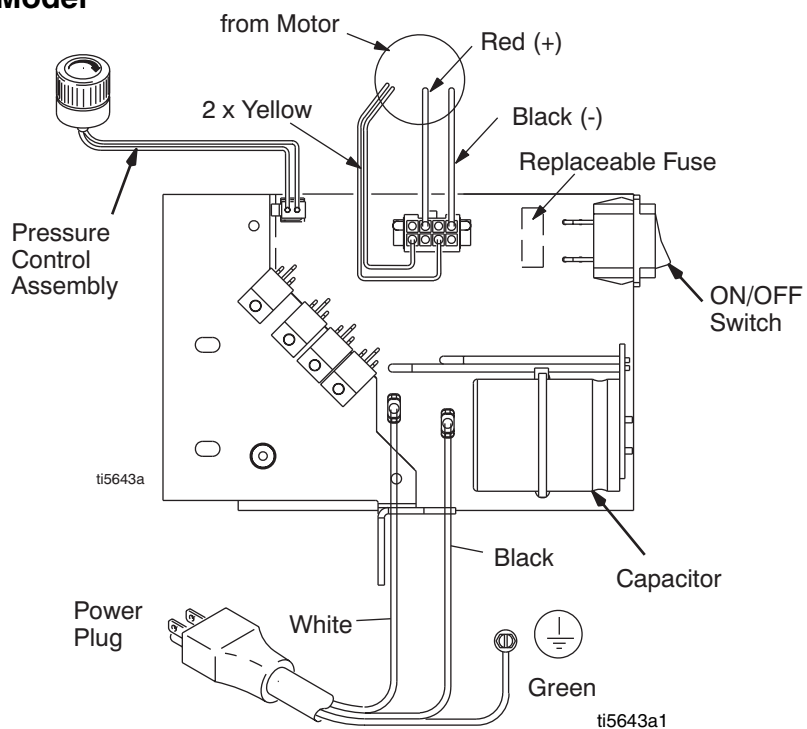



# Technical Data

Power requirements . . . . .	100/120V AC, 50/60 hz, 11A, 1 phase
Generator required . . . . .	3000 w minimum
Maximum working pressure . . . . .	3300 psi (22.7 MPa, 227 bar)
Cycles per gallon (liter). . . . .	680 (180)
Maximum delivery gpm (lpm) . . . . .	0.47 (1.8)
Maximum tip size . . . . .	0.021
Fluid outlet npsm . . . . .	1/4 in.
Dimensions (826084):	
Length . . . . .	15.75 in. (40.0 cm)
Width . . . . .	14.0 in. (36.0 cm)
Height. . . . .	17 in. (43.0 cm)
Dimensions (826098):	
Length . . . . .	20.0 in. (50.8 cm)
Width . . . . .	15.5 in. (39.4 cm)
Height. . . . .	19.25 in. (48.9 cm)
Weight (826084): . . . . .	32 lbs (14.5 kg)
Weight (826098) . . . . .	40 lbs (18.1 kg)
Wetted parts . . . . .	zinc and nickel-plated carbon steel, nylon, stainless steel, PTFE, Acetal, leather, UHMWPE, aluminum, tungsten carbide
Noise level*	
Sound power (ISO 3744)	100dBa*
Sound pressure (ISO 3744)	90 dBa*

*\*Measured 3 feet (1 meter) from equipment.*

# Warranty

Graco warrants all equipment referenced in this document which is manufactured by Graco and bearing its name to be free from defects in material and workmanship on the date of sale to the original purchaser for use. With the exception of any special, extended, or limited warranty published by Graco, Graco will, for a period of twelve months from the date of sale, repair or replace any part of the equipment determined by Graco to be defective. This warranty applies only when the equipment is installed, operated and maintained in accordance with Graco's written recommendations.

This warranty does not cover, and Graco shall not be liable for general wear and tear, or any malfunction, damage or wear caused by faulty installation, misapplication, abrasion, corrosion, inadequate or improper maintenance, negligence, accident, tampering, or substitution of non-Graco component parts. Nor shall Graco be liable for malfunction, damage or wear caused by the incompatibility of Graco equipment with structures, accessories, equipment or materials not supplied by Graco, or the improper design, manufacture, installation, operation or maintenance of structures, accessories, equipment or materials not supplied by Graco.

This warranty is conditioned upon the prepaid return of the equipment claimed to be defective to an authorized Graco distributor for verification of the claimed defect. If the claimed defect is verified, Graco will repair or replace free of charge any defective parts. The equipment will be returned to the original purchaser transportation prepaid. If inspection of the equipment does not disclose any defect in material or workmanship, repairs will be made at a reasonable charge, which charges may include the costs of parts, labor, and transportation.

**THIS WARRANTY IS EXCLUSIVE, AND IS IN LIEU OF ANY OTHER WARRANTIES, EXPRESS OR IMPLIED, INCLUDING BUT NOT LIMITED TO WARRANTY OF MERCHANTABILITY OR WARRANTY OF FITNESS FOR A PARTICULAR PURPOSE.**

Graco's sole obligation and buyer's sole remedy for any breach of warranty shall be as set forth above. The buyer agrees that no other remedy (including, but not limited to, incidental or consequential damages for lost profits, lost sales, injury to person or property, or any other incidental or consequential loss) shall be available. Any action for breach of warranty must be brought within two (2) years of the date of sale.

**GRACO MAKES NO WARRANTY, AND DISCLAIMS ALL IMPLIED WARRANTIES OF MERCHANTABILITY AND FITNESS FOR A PARTICULAR PURPOSE, IN CONNECTION WITH ACCESSORIES, EQUIPMENT, MATERIALS OR COMPONENTS SOLD BUT NOT MANUFACTURED BY GRACO.** These items sold, but not manufactured by Graco (such as electric motors, switches, hose, etc.), are subject to the warranty, if any, of their manufacturer. Graco will provide purchaser with reasonable assistance in making any claim for breach of these warranties.

In no event will Graco be liable for indirect, incidental, special or consequential damages resulting from Graco supplying equipment hereunder, or the furnishing, performance, or use of any products or other goods sold hereto, whether due to a breach of contract, breach of warranty, the negligence of Graco, or otherwise.

## **FOR GRACO CANADA CUSTOMERS**

The Parties acknowledge that they have required that the present document, as well as all documents, notices and legal proceedings entered into, given or instituted pursuant hereto or relating directly or indirectly hereto, be drawn up in English. Les parties reconnaissent avoir convenu que la rédaction du présente document sera en Anglais, ainsi que tous documents, avis et procédures judiciaires exécutés, donnés ou intentés, à la suite de ou en rapport, directement ou indirectement, avec les procédures concernées.

## **POUR LES CLIENTS DE GRACO PARLANT FRANCAIS**

Les parties reconnaissent avoir convenu que la rédaction du présent document ainsi que de tous les documents, avis et procédures judiciaires exécutés, donnés ou intentés à la suite de ou en rapport, directement ou indirectement, avec les procédures concernées, sera en anglais.

## **FÜR GRACO-KUNDEN IN DEUTSCHLAND/ÖSTERREICH/SCHWEIZ**

Die Parteien bestätigen hiermit die festgelegte Vereinbarung, daß das vorliegende Dokument sowie alle anderen Dokumente, Mitteilungen und Gerichtsverfahren, die im Zusammenhang damit erstellt, verteilt oder eingeleitet werden, oder sich direkt oder indirekt darauf beziehen, in englischer Sprache verfaßt sein sollen.

## **PARA LOS CLIENTES DE GRACO QUE HABLAN ESPAÑOL**

Las partes reconocen haber convenido que el presente documento, así como todos los documentos, notificaciones y procedimientos judiciales emprendidos, presentados o establecidos que tengan que ver con estas garantías directa o indirectamente, estarán redactados en inglés.

## **PER I CLIENTI GRACO ITALIANI**

Le controparti riconoscono di aver richiesto che il presente documento, e tutti gli altri documenti, avvisi e informazioni di natura legale sottoscritti, conferiti o istituiti direttamente o indirettamente, siano redatti in lingua inglese.

## **VOOR GRACO-KLANTEN IN NEDERLAND**

De partijen zijn zich ervan bewust dat zij hebben geëist dat het onderhavige document, evenals alle documenten, berichtgevingen en wettelijke procedures die worden aangegaan, overhandigd of in gang gezet hetzij als gevolg van hetzij rechtstreeks hetzij indirect in relatie tot het onderhavige worden opgesteld in de Engelse taal.

## **ADDITIONAL WARRANTY COVERAGE**

Graco does provide extended warranty and wear warranty for products described in the "Graco Contractor Equipment Warranty Program".

*TO PLACE AN ORDER*, contact your Graco distributor, or call **1-800-690-2894** to identify the nearest distributor.

All written and visual data contained in this document reflects the latest product information available at the time of publication. Graco reserves the right to make changes at any time without notice.

mm 312859

This manual contains English

**Graco Headquarters:** Minneapolis,

**International Offices:** Belgium, Korea, China, Japan

**GRACO INC. P.O. BOX 1441 MINNEAPOLIS, MN 55440-1441**

<http://www.graco.com>

01/2008