

Gun Flush Box Kit

312784J

EN

Kit includes parts to install a Graco Gun Flush Box in a ProMix[®] 2KS, ProMix[®] 2KE, or ProMix[®] PD2K Proportioning System. For professional use only.

Not approved for use in European explosive atmosphere locations. Bare Gun Flush Box is approved for use in explosive atmospheres. See manual 309227.

Part No. 15V826

100 psi (0.7 MPa, 7 bar) Maximum Air Inlet Pressure



Important Safety Instructions

Read all warnings and instructions in this manual before using this equipment. Save these instructions.

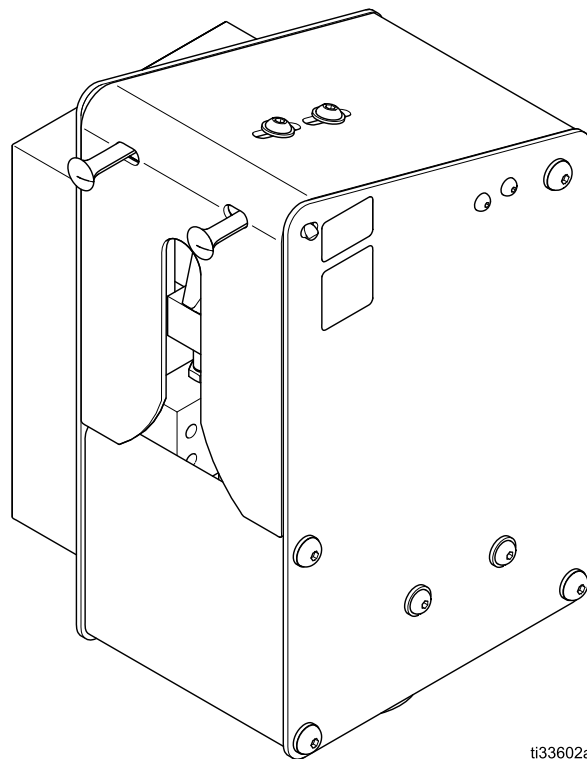

i33602a

Contents

Related Manuals 2

Warnings 3

Installation for ProMix 2KS or ProMix 2KE 5

 Location 5

 Intrinsically Safe Installation 5

 Ventilation 5

 Grounding 5

 Typical Installation 6

 Before Installing 7

 Install the Air Flow Switch 7

 Install the Pressure Switch 10

 Install the Gun Flush Box Solenoid 11

 Install the Atomizing Air Safety Shutoff Valve .. 15

 Connect the Air Tubes to the Gun Flush Box .. 15

 Trigger Height Adjustment 15

Installation for ProMix PD2K 17

 Location 17

 Intrinsically Safe Installation 17

 Ventilation 17

 Grounding 17

 Typical Installation 18

 Before Installing 19

 Connect the Air Flow Switch 19

 Install the Pressure Switch 20

 Install the Gun Flush Box Solenoid 21

 Install the Atomizing Air Safety Shutoff Valve .. 24

 Connect the Air Tubes to the Gun Flush Box .. 24

 Trigger Height Adjustment 24

Operation 26

Maintenance 27

Troubleshooting 27

Parts 28

Accessories 30

 Gun Holder 30

Technical Data 31

Graco Standard Warranty 32

Graco Information 32





Related Manuals





See the following manuals for additional information on the ProMix 2KS, ProMix 2KE, ProMix PD2K and Gun Flush Box Kits.

Manual	Description
309227	Bare Gun Flush Box
312775	ProMix 2KS Manual System Installation
312776	ProMix 2KS Manual System Operation
312777	ProMix 2KS Manual System Repair-Parts
312778	ProMix 2KS Automatic System Installation
312779	ProMix 2KS Automatic System Operation
312780	ProMix 2KS Automatic System Repair-Parts
3A0868	ProMix 2KE Pump-Based Operation
3A0869	ProMix 2KE Meter-Based Operation
3A0870	ProMix 2KE Repair-Parts
332562	ProMix PD2K Manual System Operation
332457	ProMix PD2K Manual System Installation
3A2800	ProMix PD2K Manual System Repair-Parts
3A4186	ProMix PD2K Dual Panel Manual System Operation
3A4497	ProMix PD2K Dual Panel Manual System Air Control Module

Warnings

The following warnings are for the setup, use, grounding, maintenance, and repair of this equipment. The exclamation point symbol alerts you to a general warning and the hazard symbols refer to procedure-specific risks. When these symbols appear in the body of this manual, refer back to these Warnings. Product-specific hazard symbols and warnings not covered in this section may appear throughout the body of this manual where applicable.

 WARNING	
	<p>FIRE AND EXPLOSION HAZARD</p> <p>Flammable fumes, such as solvent and paint fumes, in work area can ignite or explode. To help prevent fire and explosion:</p> <ul style="list-style-type: none"> • Use equipment only in well ventilated area. • Eliminate all ignition sources; such as pilot lights, cigarettes, portable electric lamps, and plastic drop cloths (potential static arc). • Keep work area free of debris, including solvent, rags and gasoline. • Do not plug or unplug power cords, or turn power or light switches on or off when flammable fumes are present. • Ground all equipment in the work area. See Grounding instructions. • Use only grounded hoses. • Hold gun firmly to side of grounded pail when triggering into pail. • If there is static sparking or you feel a shock, stop operation immediately. Do not use equipment until you identify and correct the problem. • Keep a working fire extinguisher in the work area.
	<p>SKIN INJECTION HAZARD</p> <p>High-pressure fluid from gun, hose leaks, or ruptured components will pierce skin. This may look like just a cut, but it is a serious injury that can result in amputation. Get immediate surgical treatment.</p> <ul style="list-style-type: none"> • Do not point gun at anyone or at any part of the body. • Do not put your hand over the spray tip. • Do not stop or deflect leaks with your hand, body, glove, or rag. • Do not spray without tip guard and trigger guard installed. • Engage trigger lock when not spraying. • Follow Pressure Relief Procedure in this manual, when you stop spraying and before cleaning, checking, or servicing equipment.
	<p>PRESSURIZED EQUIPMENT HAZARD</p> <p>Fluid from the gun/dispense valve, leaks, or ruptured components can splash in the eyes or on skin and cause serious injury.</p> <ul style="list-style-type: none"> • Follow Pressure Relief Procedure in this manual, when you stop spraying and before cleaning, checking, or servicing equipment. • Tighten all fluid connections before operating the equipment. • Check hoses, tubes, and couplings daily. Replace worn or damaged parts immediately.

 WARNING	
	<p>EQUIPMENT MISUSE HAZARD</p> <p>Misuse can cause death or serious injury.</p> <ul style="list-style-type: none"> • Do not operate the unit when fatigued or under the influence of drugs or alcohol. • Do not exceed the maximum working pressure or temperature rating of the lowest rated system component. See Technical Data in all equipment manuals. • Use fluids and solvents that are compatible with equipment wetted parts. See Technical Data in all equipment manuals. Read fluid and solvent manufacturer’s warnings. For complete information about your material, request MSDS forms from distributor or retailer. • Check equipment daily. Repair or replace worn or damaged parts immediately with genuine manufacturer’s replacement parts only. • Do not alter or modify equipment. • Use equipment only for its intended purpose. Call your distributor for information. • Route hoses and cables away from traffic areas, sharp edges, moving parts, and hot surfaces. • Do not kink or over bend hoses or use hoses to pull equipment. • Keep children and animals away from work area. • Comply with all applicable safety regulations.
	<p>TOXIC FLUID OR FUMES HAZARD</p> <p>Toxic fluids or fumes can cause serious injury or death if splashed in the eyes or on skin, inhaled, or swallowed.</p> <ul style="list-style-type: none"> • Read MSDS’s to know the specific hazards of the fluids you are using. • Store hazardous fluid in approved containers, and dispose of it according to applicable guidelines. • Always wear impervious gloves when spraying or cleaning equipment.
	<p>PERSONAL PROTECTIVE EQUIPMENT</p> <p>You must wear appropriate protective equipment when operating, servicing, or when in the operating area of the equipment to help protect you from serious injury, including eye injury, inhalation of toxic fumes, burns, and hearing loss. This equipment includes but is not limited to:</p> <ul style="list-style-type: none"> • Protective eyewear • Clothing and respirator as recommended by the fluid and solvent manufacturer • Gloves • Hearing protection



Installation for ProMix 2KS or ProMix 2KE



Use this section to install the gun flush box into a ProMix 2KS Plural Component Proportioner system, or into a ProMix 2KE Electronic Proportioner system.

See **Installation for ProMix PD2K**, page 17 to install the gun flush box into a ProMix PD2K Electronic Proportioner system.

See FIG. 1 for a typical installation of the gun flush box kit for a ProMix 2KS or a ProMix 2KE Proportioner.

FIG. 1 is only a guide. Contact your Graco distributor for assistance in designing a system to meet your application needs.

							
Do not bypass the gun flush box interlock sensors. They prevent the gun flush box from operating unless the gun is in position and the gun flush box door is locked.							

							
If using an electrostatic gun, shut off electrostatics before flushing. Follow the warnings in your electrostatic gun manual.							

Location

Locate and mount the gun flush box as explained in the Gun Flush Box manual 309227.

Intrinsically Safe Installation

Follow instructions in your proportioner manual.

Ventilation

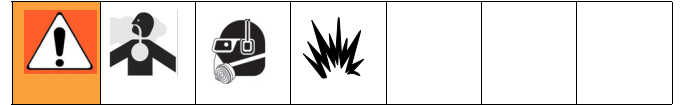

Electrically interlock the spray booth air supply (J) with ventilators, using a ventilation interlock valve (K), to prevent the gun flush box from operating when ventilating fans are not operating. See FIG. 1, page 6. Check and follow all applicable air exhaust velocity codes for your area and type of installation.

Grounding



Ground the gun flush box as explained in the Gun Flush Box manual 309227.

Gun Holder

The correct gun holder is necessary to operate the Gun Flush Box. The gun holder is sold separately. Use the gun holder that matches the spray gun to be used. See **Gun Holder**, page 31.

Typical Installation

For 2KS or 2KE System

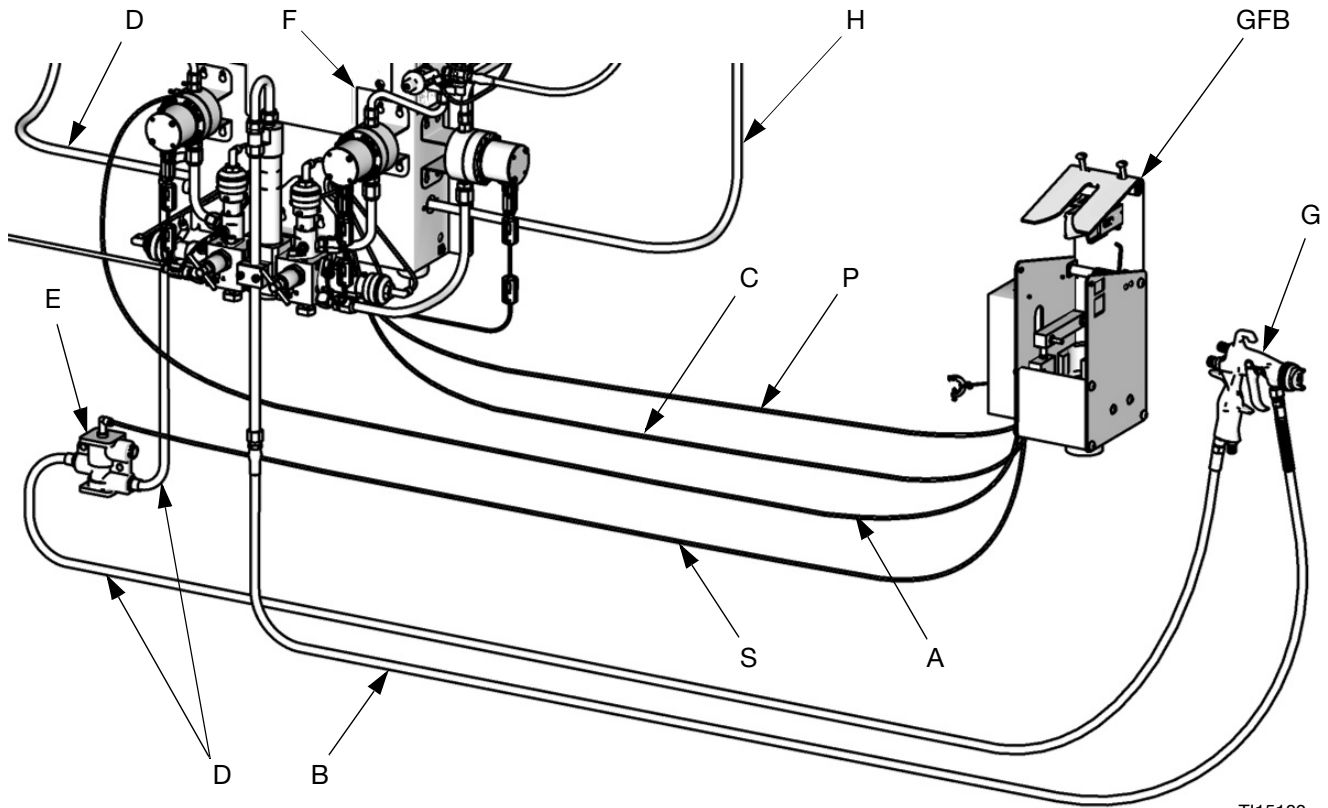

T115100a

Key:

GFB Gun Flush Box (see FIG. 11 for detail of air line connection fittings A, C, P, S)

A Air Line from GFB to Pressure Switch Input

B Fluid Supply to Gun

C Air Line from GFB to GFB Solenoid Output

D Atomizing Air Supply

E Gun Air Safety Shutoff Valve (see page 15)

F Fluid Station

G Spray Gun



H Main Air Supply Line

P Air Line from GFB to Fluid Station Main Air Manifold

S Air Line from GFB to Gun Air Safety Shutoff Valve Pilot Port

FIG. 1: Typical Installation (ProMix 2KS System Shown)

Before Installing

						
---	---	---	--	--	--	--

- To avoid electric shock, turn off EasyKey power or 2KS system power before installing.
- All electrical wiring must be done by a qualified electrician and comply with all local codes and regulations.
- Do not substitute system components as this may impair intrinsic safety.
- Read **Warnings**, starting on page 3.

NOTICE

To avoid damaging circuit board when servicing, wear Part No. 112190 grounding strap on wrist and ground appropriately.

1. Close main air shutoff valve on air supply line and on proportioner.
2. Shut off proportioner power. FIG. 2.
3. Loosen the four screws and remove the Fluid Station cover.

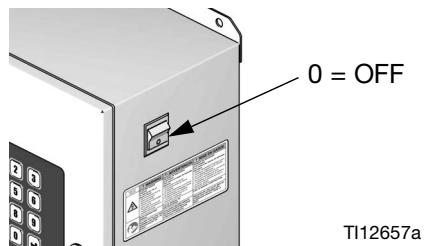
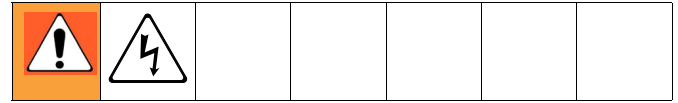

FIG. 2: Power Off (ProMix 2KS Shown)

Install the Air Flow Switch



NOTE: Each gun flush box includes one air flow switch (AFS). Install the air flow switch as shown in FIG. 3. If you are using a second gun flush box, install its air flow switch next to the first switch, as shown.

1. Follow **Before Installing**, page 7.
2. See FIG. 3 for the ProMix 2KS or FIG. 4 for the ProMix 2KE. Position the air flow switch (102) as shown. Install the nipple (103) and elbow (104). Assemble the bulkhead fitting (105) as shown, to secure the switch to the side of the panel.
3. Route the air flow switch wires through the designated strain relief (K). Connect AFS#1 wires to pins 1 and 2. *ProMix 2KS only:* Connect AFS#2 wires (if used) to pins 3 and 4.
4. See FIG. 1. Connect a 1/4 npt atomizing air line (D) from the AFS outlet nipple (103) to the air inlet port of the air safety shutoff valve (E, also see FIG. 10). Connect another length of atomizing air line (D) from the safety valve outlet port to the gun (G) air inlet.
5. See FIG. 3 for the ProMix 2KS or FIG. 4 for the ProMix 2KE. Install an appropriate air inlet fitting (L) into the bulkhead fitting (105). The air inlet fitting must be 1/4 npt(m) on the bulkhead end. The other end must be sized to mate with your main air supply line.

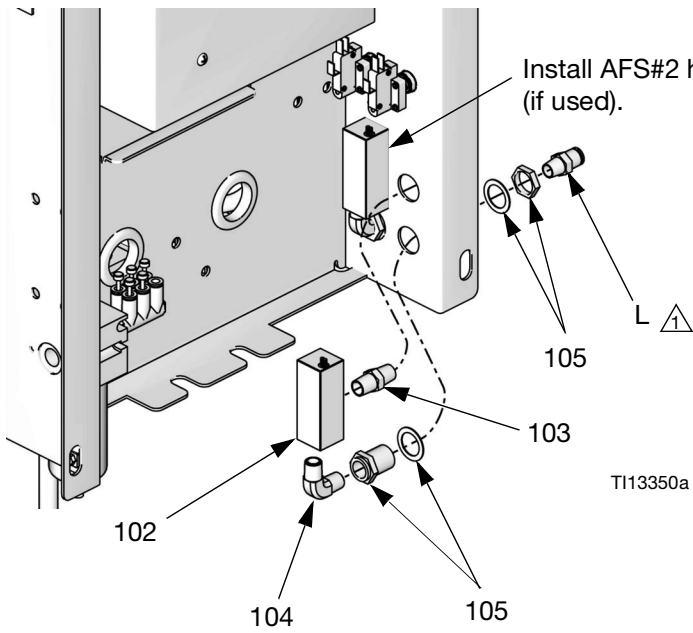

Install Air Flow Switch on Back of Fluid Station Panel

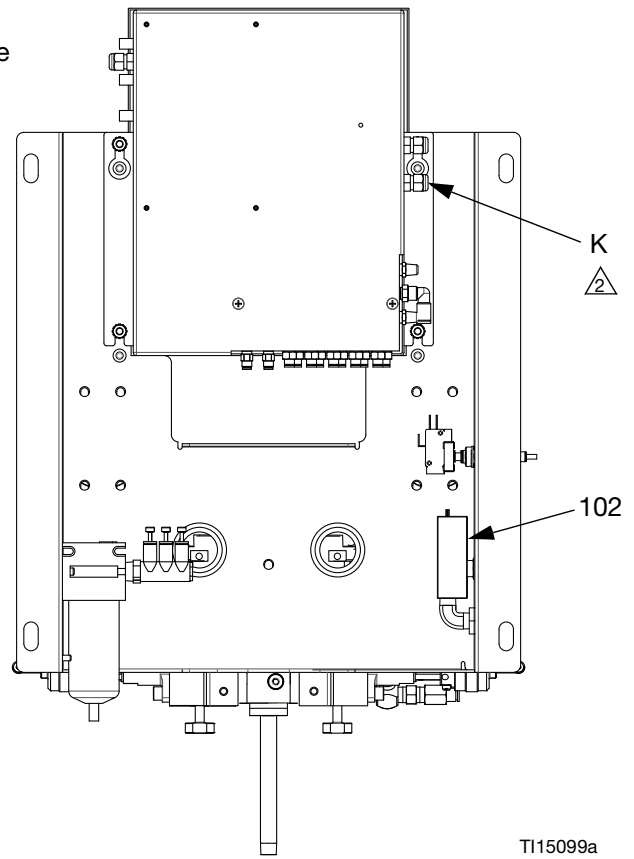

Back View of Fluid Station Panel

- 1 User supplied air inlet fitting (L) must be 1/4 npt(m) to mate with bulkhead fitting (105).
- 2 Route AFS wires through this strain relief (K) to Fluid Station Control Board.
- 3 Connect AFS#1 wires to J1 pins 1 and 2 on Fluid Station Control Board.
- 4 Connect AFS#2 wires to J1 pins 3 and 4 on Fluid Station Control Board.

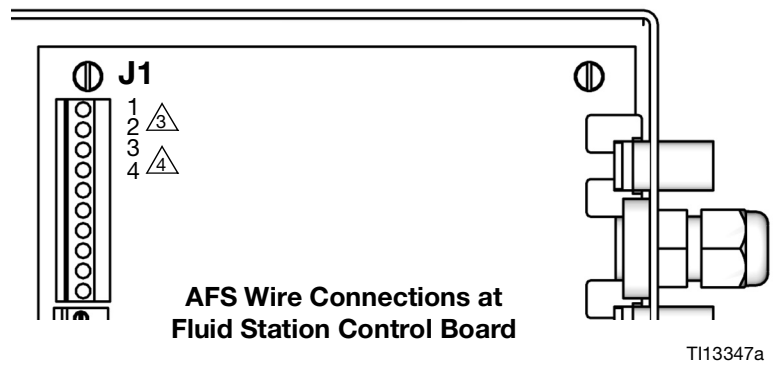
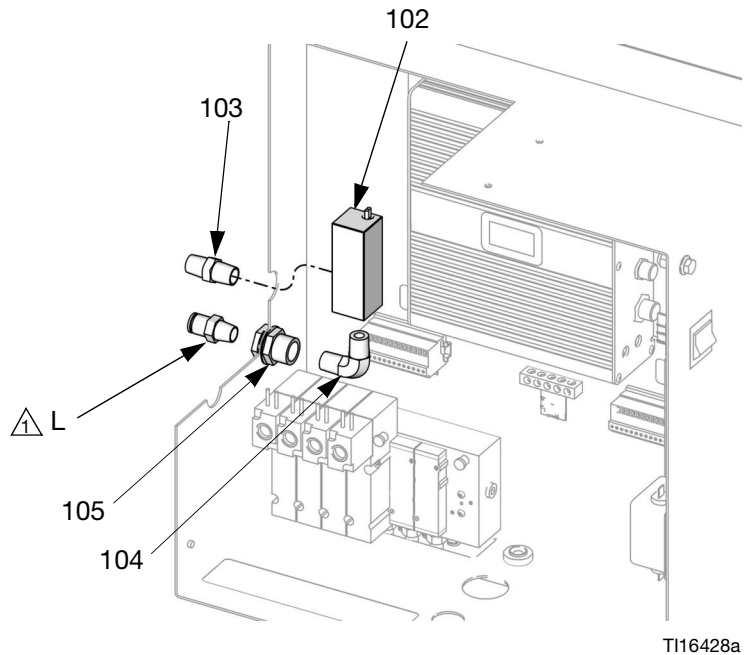

FIG. 3: Installing the Air Flow Switch on a ProMix 2KS

- ⚠ 1 User supplied air inlet fitting (L) must be 1/4 npt(m) to mate with bulkhead fitting (105).
- ⚠ 2 Connect AFS#1 wires to pins 1 and 2.
- ⚠ 3 Connect AFS#2 wires to pins 7 and 8.



TI16428a

Install GFB Pressure Switch (107) here

Install Air Flow Switch in Control Box

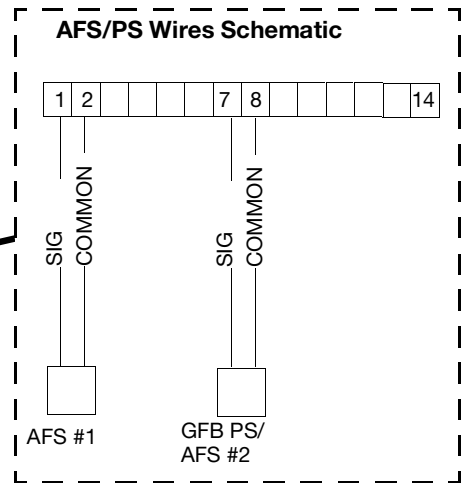
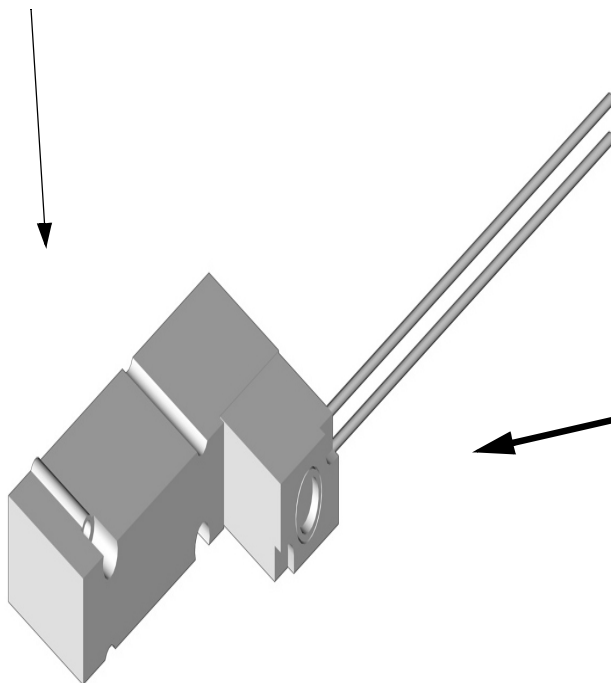

ti15730a

FIG. 4: Installing the Air Flow Switch and Pressure Switch on a ProMix 2KE

Install the Pressure Switch

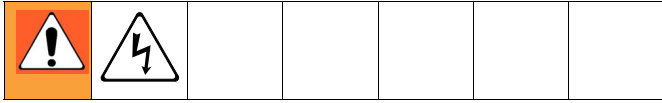

NOTE: Each gun flush box includes one pressure switch (PS). Install the pressure switch as shown in FIG. 5 for the ProMix 2KS or FIG. 4 for the ProMix 2KE. If you are using a second gun flush box, install its pressure switch next to the first switch, as shown.

1. Follow **Before Installing**, page 7.

2. Position pressure switch (107) as shown. Install bulkhead fitting (108) to secure the switch to the side of the panel. Install tubing adapter (118) in the bulkhead fitting.
3. Route the pressure switch wires through the designated strain relief (K). Connect PS#1 wires to pins 7 and 8. Connect PS#2 wires (if used) to pins 9 and 10.
4. Connect a 5/32 in. (4 mm) OD air tube from the tube adapter (118) to the **A** port on the bottom of the gun flush box. See FIG. 1 and FIG. 11.

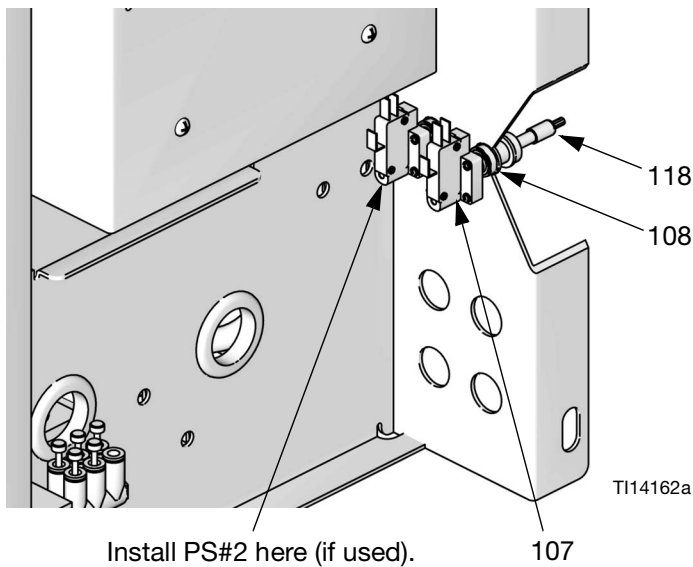

Install Pressure Switch on Back of Fluid Station Panel

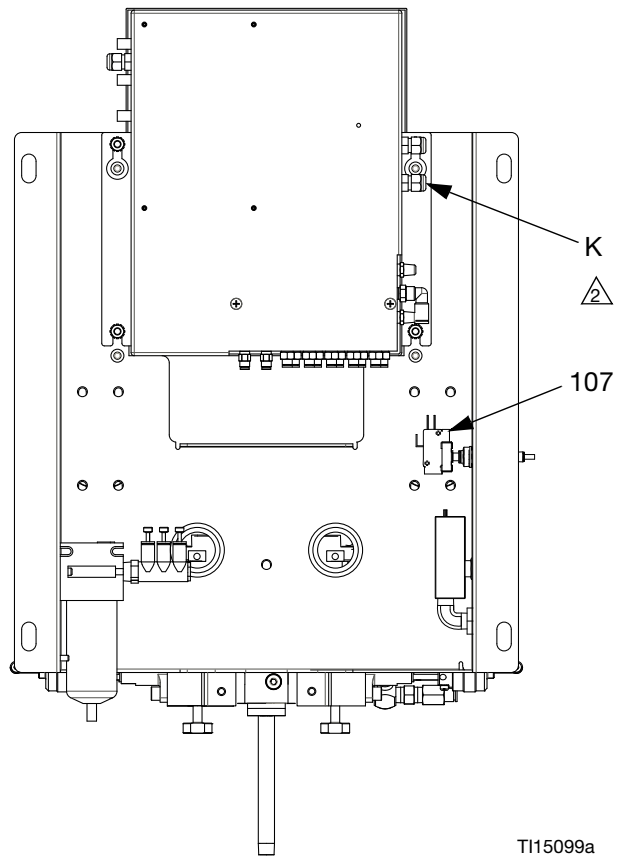

Back View of Fluid Station Panel

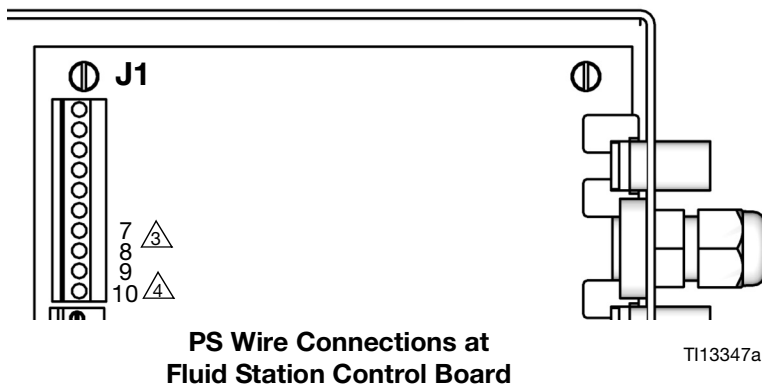

- △ Route PS wires through this strain relief (K) to Fluid Station Control Board.
- △ Connect PS#1 wires to J1 pins 7 and 8 on Fluid Station Control Board.
- △ Connect PS#2 wires to J1 pins 9 and 10 on Fluid Station Control Board.

FIG. 5: Installing the Pressure Switch on a ProMix 2KS

Install the Gun Flush Box Solenoid

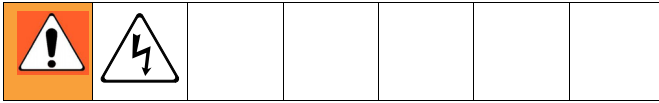

NOTE: Each gun flush box includes one solenoid (109). Install the solenoid in the fluid station panel, as shown in FIG. 6. If you are using a second gun flush box, install its solenoid next to the first solenoid, as shown.

1. Follow **Before Installing**, page 7.
2. Install the solenoid valve (109) in the correct position as shown in FIG. 6 for the ProMix 2KS or FIG. 7 for the ProMix 2KE. Secure with the two screws supplied.
3. Connect the GFB#1 solenoid wires as shown in FIG. 6 for the ProMix 2KS or FIG. 7 for the ProMix 2KE. Also see the Electrical Schematic (FIG. 8 or FIG. 9).
4. Remove the plug from the solenoid manifold and install the tube fitting connector (110).

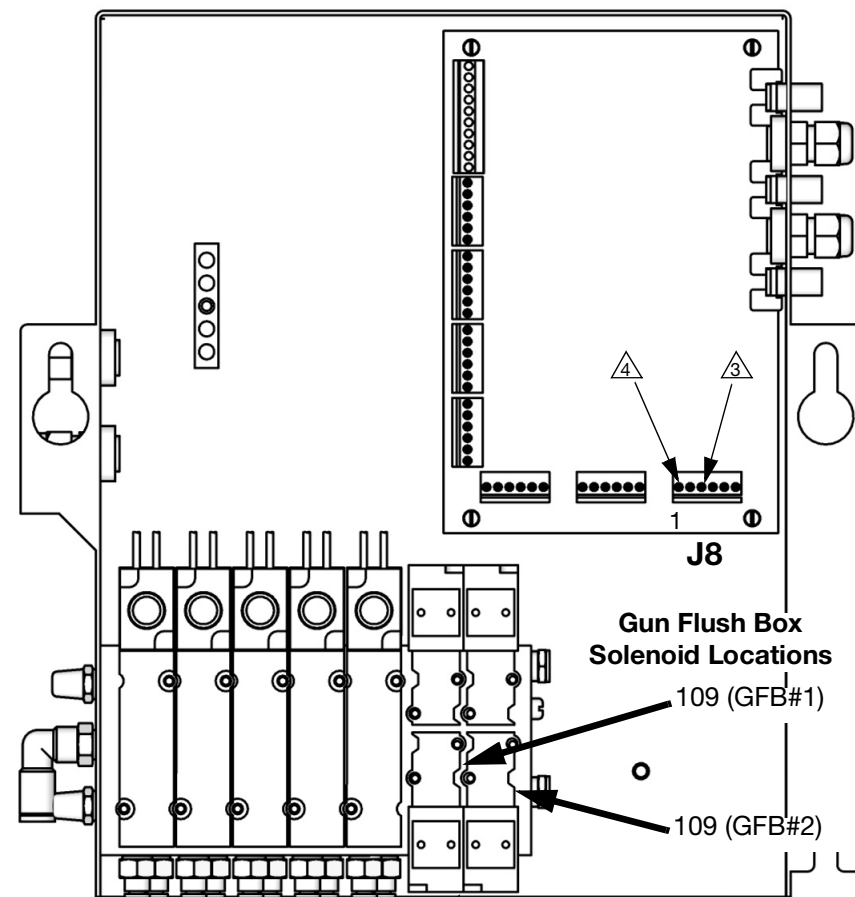

T112652a

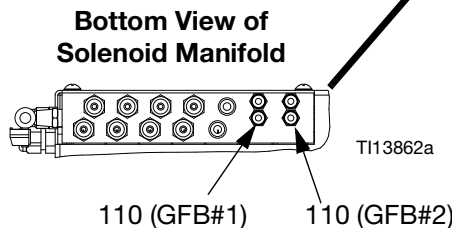

T113862a

- ③ Connect GFB#1 solenoid wires to J8 pins 3 (red) and 4 (black) on Fluid Station Control Board.
- ④ Connect GFB#2 solenoid wires to J8 pins 1 (red) and 2 (black) on Fluid Station Control Board.

FIG. 6: Installing Gun Flush Box Solenoid Valve on a ProMix 2KS

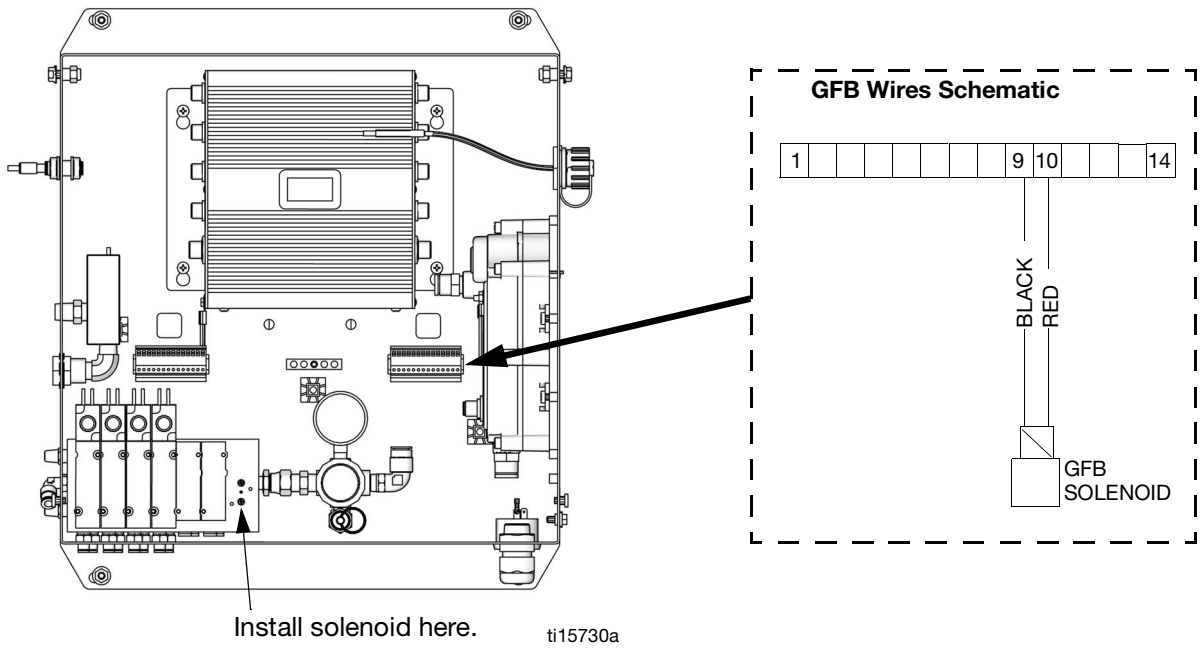

FIG. 7: Installing the Gun Flush Box Solenoid Valve on a ProMix 2KE

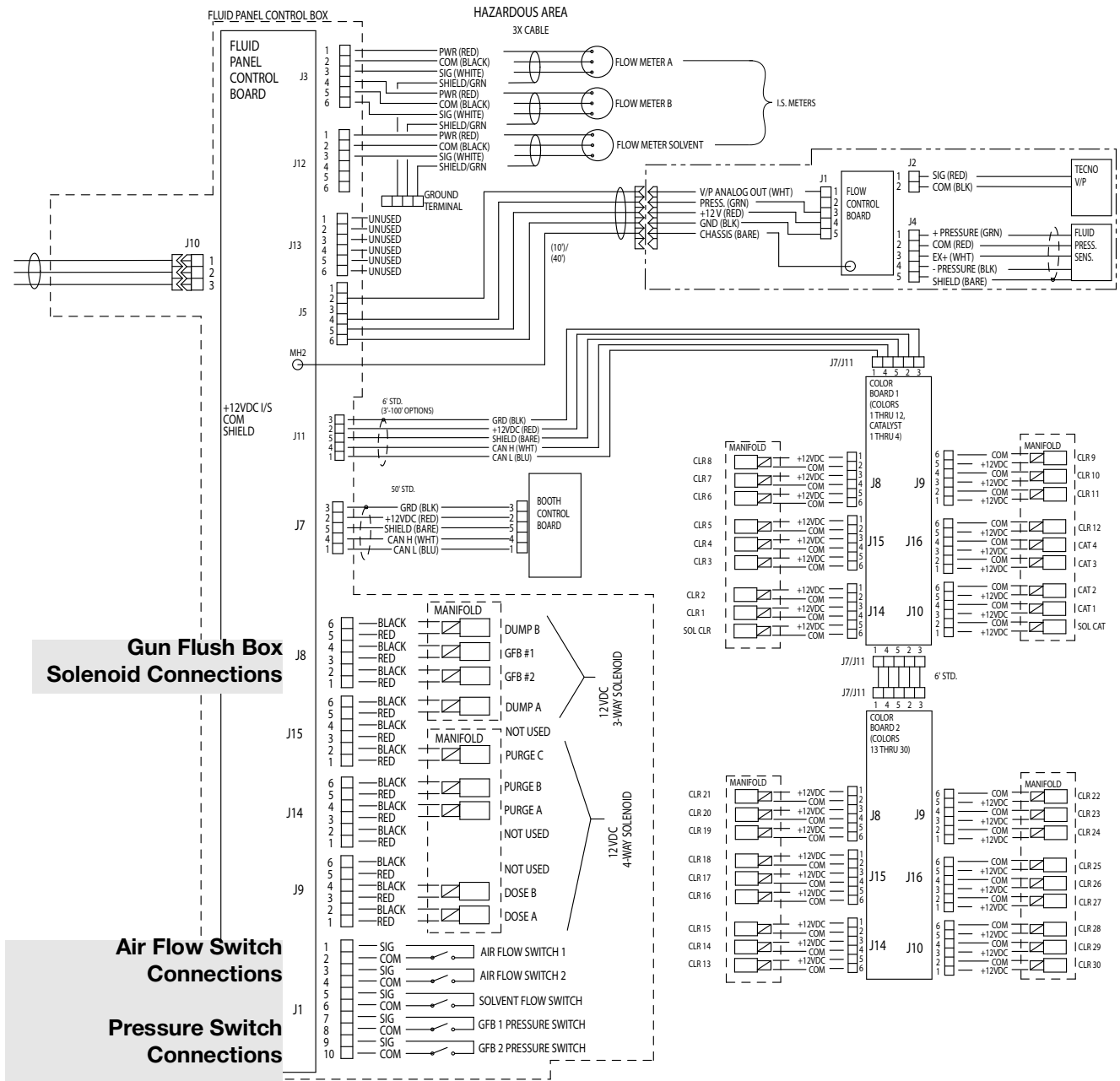

FIG. 8: System Electrical Schematic (ProMix 2KS)

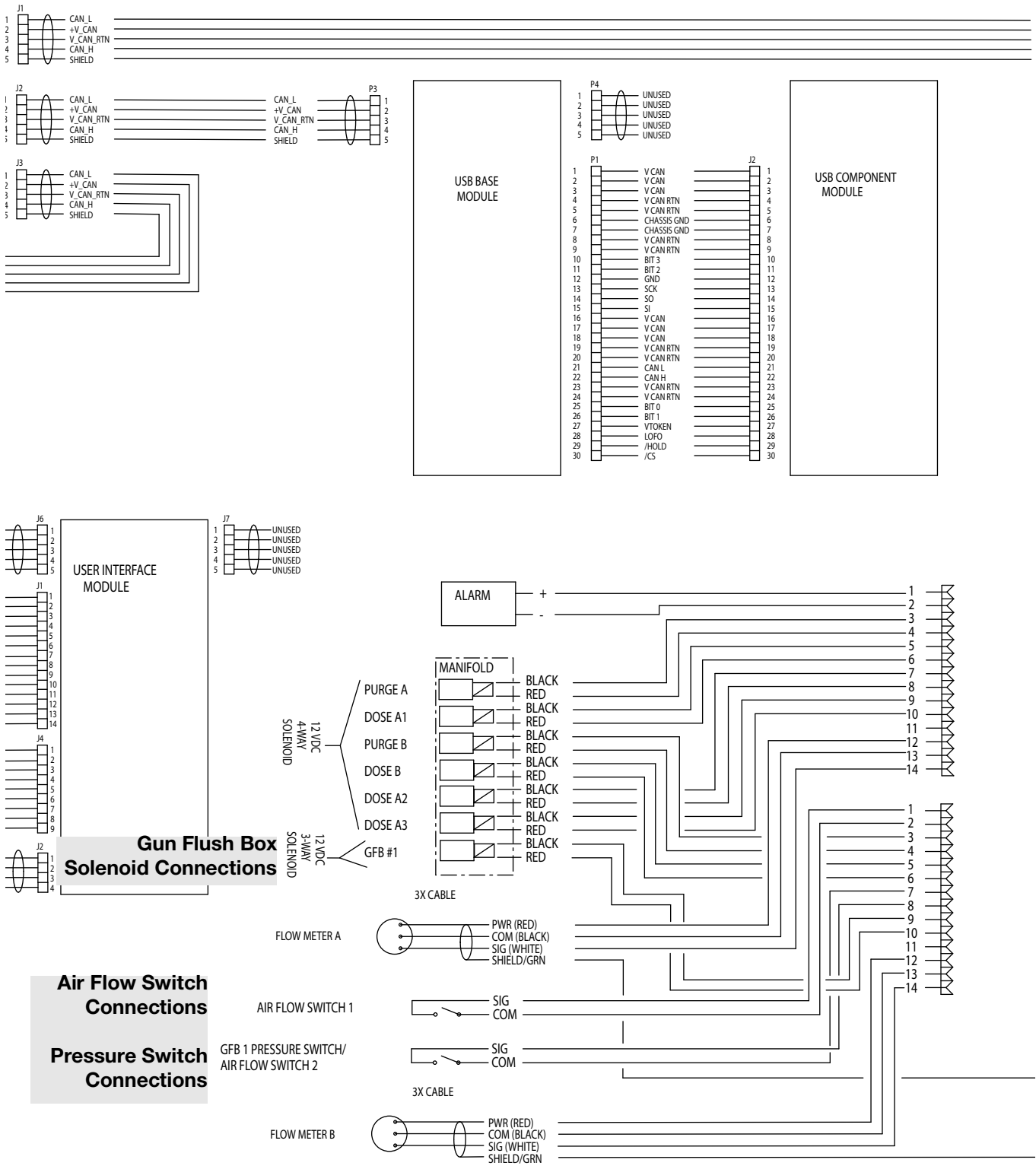

Fig. 9: System Electrical Schematic (ProMix 2KE)

Install the Atomizing Air Safety Shutoff Valve

1. Mount the safety shutoff valve securely.
2. Connect the gun atomizing air from the ProMix 2KS air flow switch to the safety shutoff valve IN port. See FIG. 1 and FIG. 10.
3. Connect an air line from the safety shutoff valve OUT port to the gun air inlet.

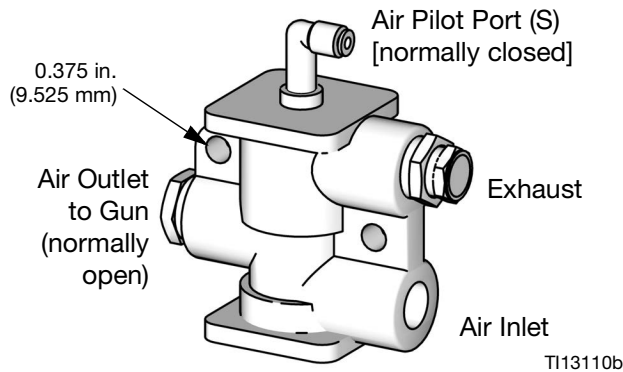

FIG. 10: Air Safety Shutoff Valve

Connect the Air Tubes to the Gun Flush Box

You must connect safety interlock air to prevent atomizing air from turning on during flushing.						

The four gun flush box air fittings are labeled as follows. See FIG. 11.

Label	Function
P	Gun flush box supply air input
A	Return air/pressure switch signal (sends air to the pressure switch when gun is ready for flushing or filling)
C	Gun trigger cylinders air (activates gun trigger for flushing or filling the gun)
S	Safety interlock (locks out atomizing air except when gun is ready to spray)

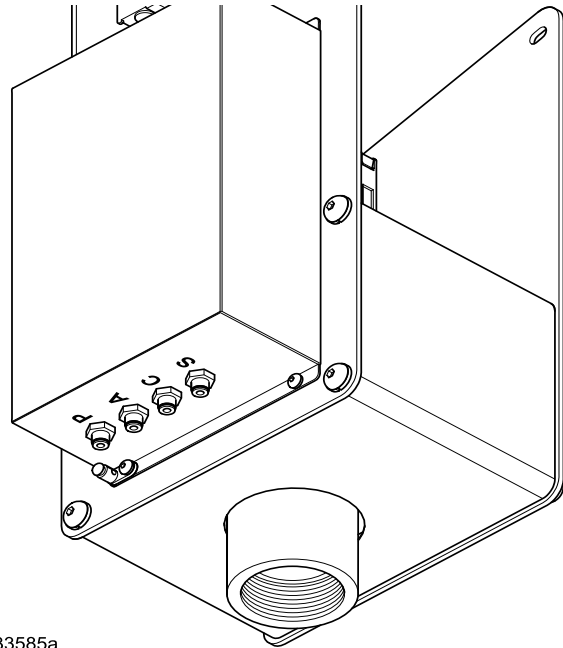

ti33585a
FIG. 11: Gun Flush Box Air Fittings (Bottom View)

NOTE: Use 5/32 in. (4 mm) OD tubing. Connect tubing as follows:

1. From the **P** fitting to the air supply manifold (M, FIG. 12). Use a clean, dry air supply (filtered to 10 microns).
2. From the **A** fitting to the pressure switch air input (PS, FIG. 12).
3. From the **C** fitting to the gun flush box solenoid (GFB, FIG. 12) output.
4. From the **S** fitting to the atomizing air safety shutoff valve pilot port (FIG. 10).

Trigger Height Adjustment

Adjust the trigger height to ensure the gun triggers during purging. See the Gun Flush Box manual 309227.

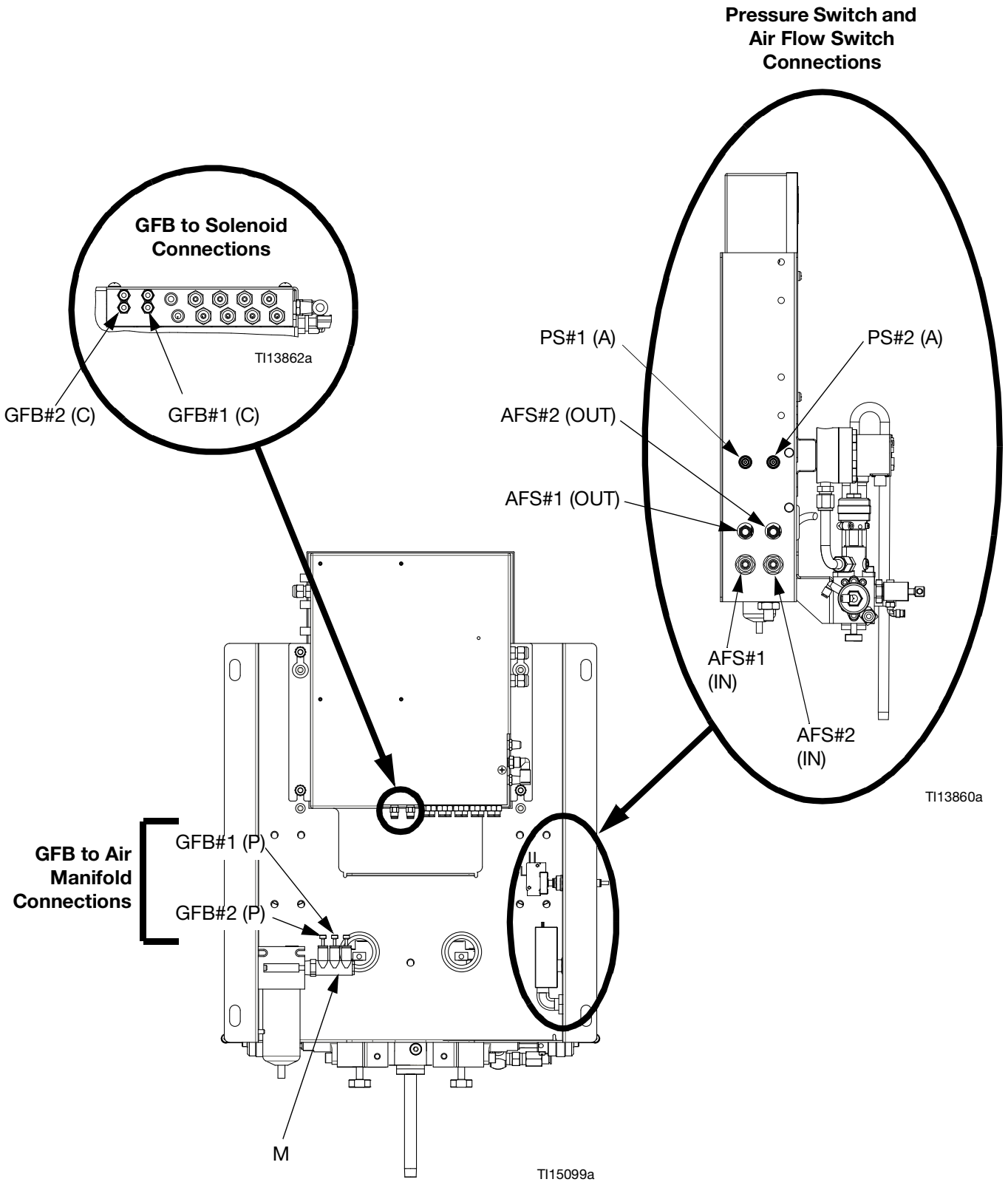

FIG. 12: GFB Solenoid, Air Manifold, Pressure Switch, and Air Flow Switch Connections (ProMix 2KS shown)



Installation for ProMix PD2K



Use this section to install the gun flush box into a ProMix PD2K Electronic Proportioner system.

See **Installation for ProMix 2KS or ProMix 2KE**, page 5 to install the gun flush box into a ProMix 2KS Plural Component Proportioner system, or into a ProMix 2KE Electronic Proportioner system.

See FIG. 13 for a typical installation of the gun flush box kit for a PD2K Electronic Proportioner.

FIG. 13 is only a guide. Contact your Graco distributor for assistance in designing a system to meet your application needs.

						
Do not bypass the gun flush box interlock sensors. They prevent the gun flush box from operating unless the gun is in position and the gun flush box door is locked.						

						
If using an electrostatic gun, shut off electrostatics before flushing. Follow the warnings in your electrostatic gun manual.						

Location

Locate and mount the gun flush box as explained in the Gun Flush Box manual 309227.

Intrinsically Safe Installation

Follow instructions in your proportioner manual.

Ventilation

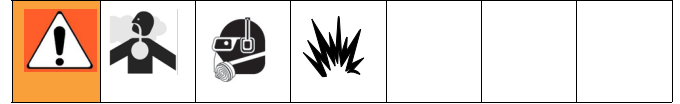

Electrically interlock the spray booth air supply (J) with ventilators, using a ventilation interlock valve (K), to prevent the gun flush box from operating when ventilating fans are not operating. See FIG. 13, page 18. Check and follow all applicable air exhaust velocity codes for your area and type of installation.

Grounding



Ground the gun flush box as explained in the Gun Flush Box manual 309227.

Gun Holder

The correct gun holder is necessary to operate the Gun Flush Box. The gun holder is sold separately. Use the gun holder that matches the spray gun to be used. See **Gun Holder**, page 31.

Typical Installation

For PD2K System

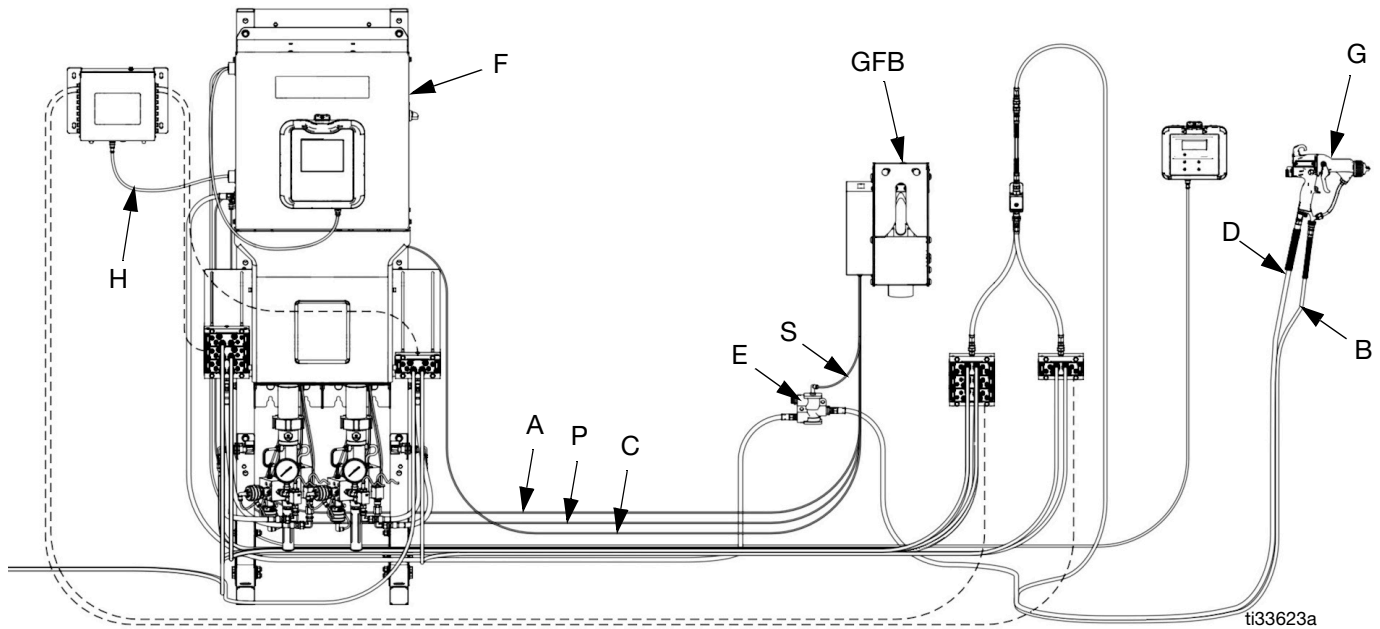

Key:

GFB Gun Flush Box (see FIG. 23 for detail of air line connection fittings A, C, P, S)

A Air Line from GFB to Pressure Switch Input

B Fluid Supply to Gun

C Air Line from GFB to GFB Solenoid Output

D Atomizing Air Supply

E Gun Air Safety Shutoff Valve (see page 24)

F PD2K Proportioner

G Spray Gun

H Main Air Supply Line

P Air Line from GFB to Fluid Station Main Air Manifold

S Air Line from GFB to Gun Air Safety Shutoff Valve Pilot

FIG. 13: Typical Installation (ProMix PD2K System Shown)

Before Installing

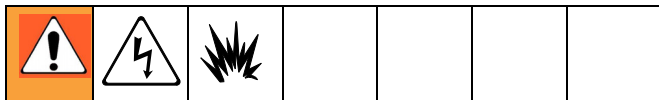

- To avoid electric shock, turn off PD2K system power before installing.
- All electrical wiring must be done by a qualified electrician and comply with all local codes and regulations.
- Do not substitute system components as this may impair intrinsic safety.
- Read **Warnings**, starting on page 3.

NOTICE

To avoid damaging circuit board when servicing, wear Part No. 112190 grounding strap on wrist and ground appropriately.

1. Close main air shutoff valve on air supply line.
2. Shut off the power switch (P) at the electrical control box. FIG. 14.
3. If servicing the electrical control box, shut off power at the main circuit breaker before opening the enclosure.
4. Loosen the four screws and remove the electrical control box cover.

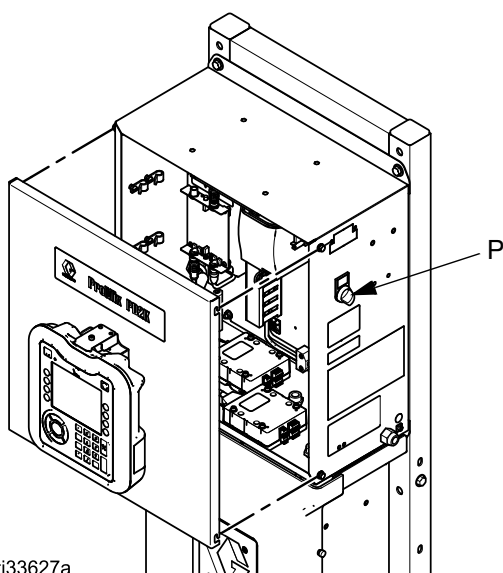

ti33627a

FIG. 14: ProMix PD2K Power Switch

Connect the Air Flow Switch

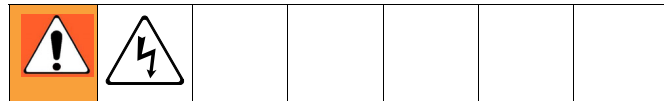

The PD2K system already has an installed air flow switch (102) FIG. 15. The air flow switch included with the gun flush box can be saved for spare parts.

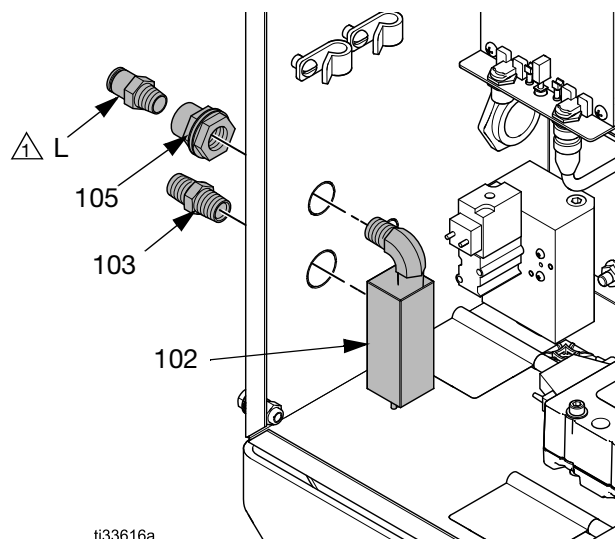

User supplied air inlet fitting (L) must be 1/4 npt(m) to mate with bulkhead fitting (105).

FIG. 15: ProMix PD2K Air Flow Switch

1. See FIG. 13. Connect a 1/4 npt atomizing air line (D) from the AFS outlet nipple (103) to the air inlet port of the air safety shutoff valve (E, also see FIG. 22). Connect another length of atomizing air line (D) from the safety valve outlet port to the gun (G) air inlet.
2. See FIG. 15. Install an appropriate air inlet fitting (L) into the bulkhead fitting (105). The air inlet fitting must be 1/4 npt(m) on the bulkhead end. The other end must be sized to mate with your main air supply line.

Install the Pressure Switch

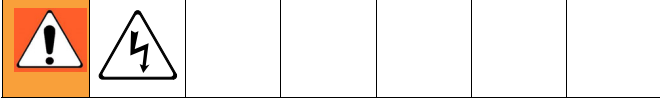

NOTE: Each gun flush box includes one pressure switch (PS). Install the pressure switch as shown in FIG. 16 for the ProMix PD2K.

1. Follow **Before Installing**, page 19.
2. Knock out (K) on the side of the electrical control box.
3. Position pressure switch (107) as shown. Install bulkhead fitting (108) to secure the switch to the side of the panel. Install tubing adapter (118) in the bulkhead fitting.

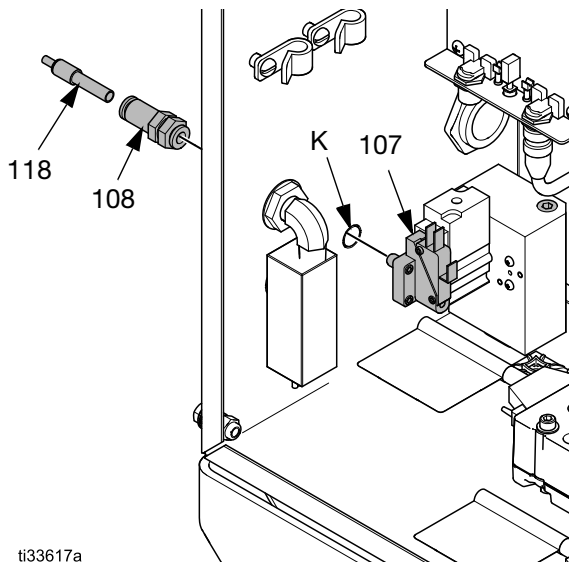

FIG. 16: Install Pressure Switch Inside Electrical Control Box

4. Route the pressure switch wires through the wire duct. Connect PS wires to pins 9 and 10 on connector 6 of the EFCM. See FIG. 17 and the electrical schematic (FIG. 21).
5. Connect a 5/32 in. (4 mm) OD air tube from the tube adapter (118) to the **A** port on the bottom of the gun flush box. See FIG. 13 and FIG. 23.

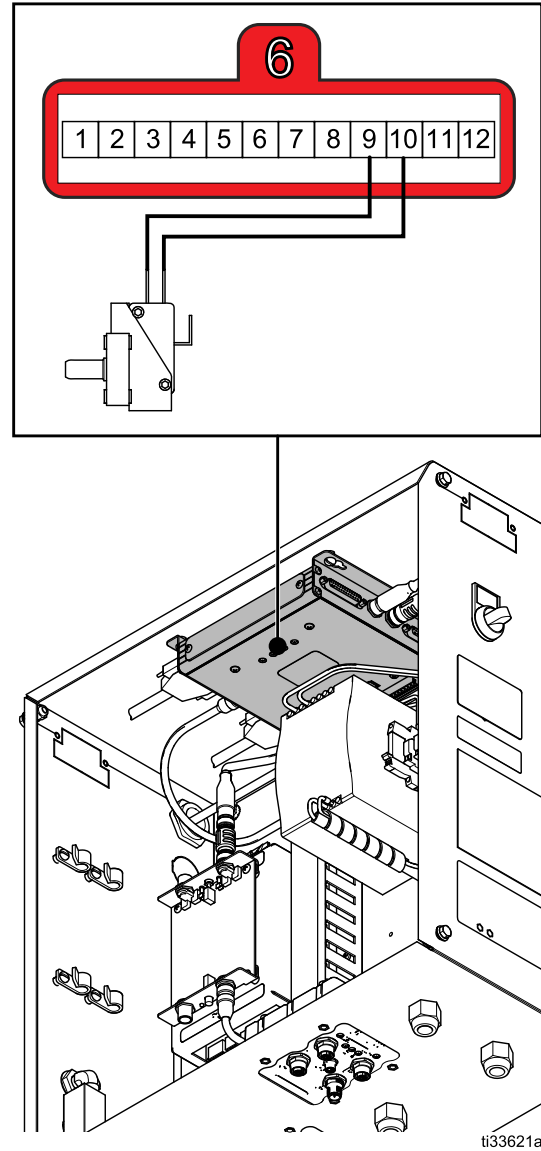
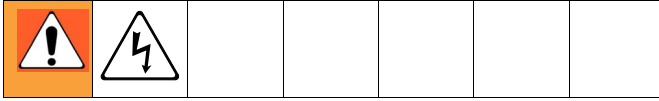

FIG. 17: Wire Pressure Switch to EFCM

Install the Gun Flush Box Solenoid



NOTE: Each gun flush box includes one solenoid (109). Install the solenoid onto the air supply manifold block, as shown in FIG. 18 and FIG. 19.

1. Follow **Before Installing**, page 19.
2. Remove two plugs (PL) from the manifold block where the solenoid valve will be installed.
3. Install solenoid valve (109) in the correct position as shown in FIG. 18. Secure with the two screws supplied.

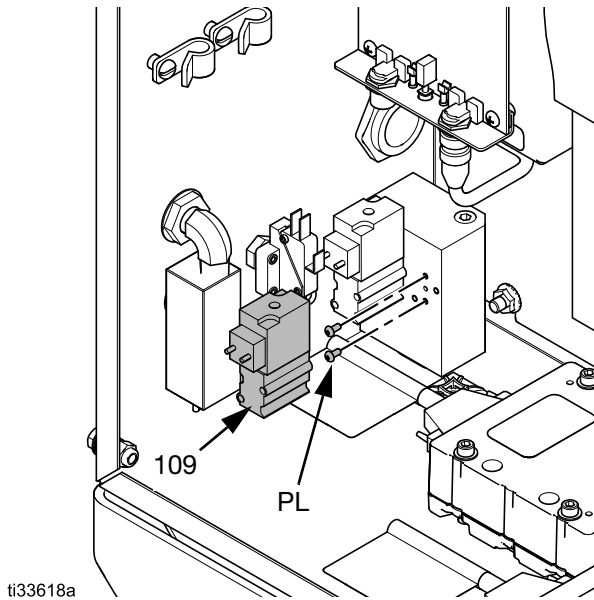

FIG. 18: Install GFB Solenoid

4. Remove the plug (PL) from the solenoid manifold and install elbow (119). Run tubing from elbow (119) to port C. Remove tube from GFB port and install fitting (120). Reattach tubing to one port of the fitting(120) and install reducer (118) into second port. Run tubing from reducer(118) to port P on GFB.

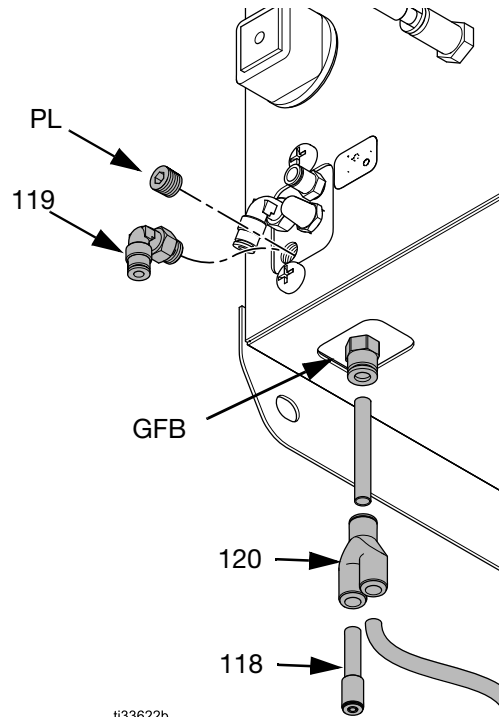

FIG. 19: GFB Solenoid Connections

5. Route the GFB solenoid wires through the wire duct. Connect the solenoid wires to pin 1 (red) and pin 2 (black) on connector 5 of the EFCM. See FIG. 20 and the Electrical Schematic (FIG. 21).

6. Connect the solenoid wires to pins 1 and 2 on connector 5 of the EFCM. See FIG. 20 and the Electrical Schematic (FIG. 21).

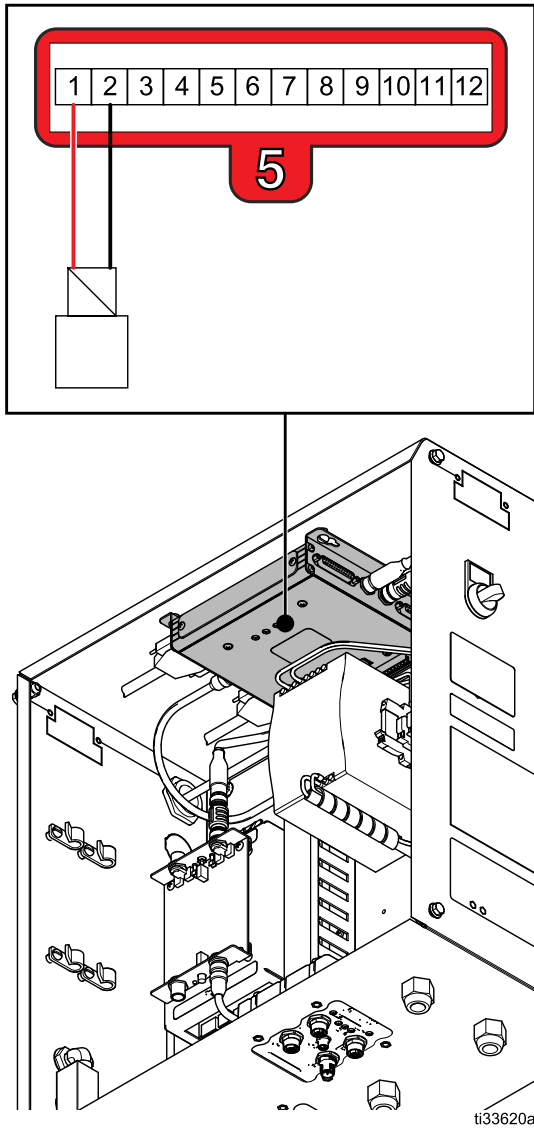

FIG. 20: Wire Solenoid to EFCM

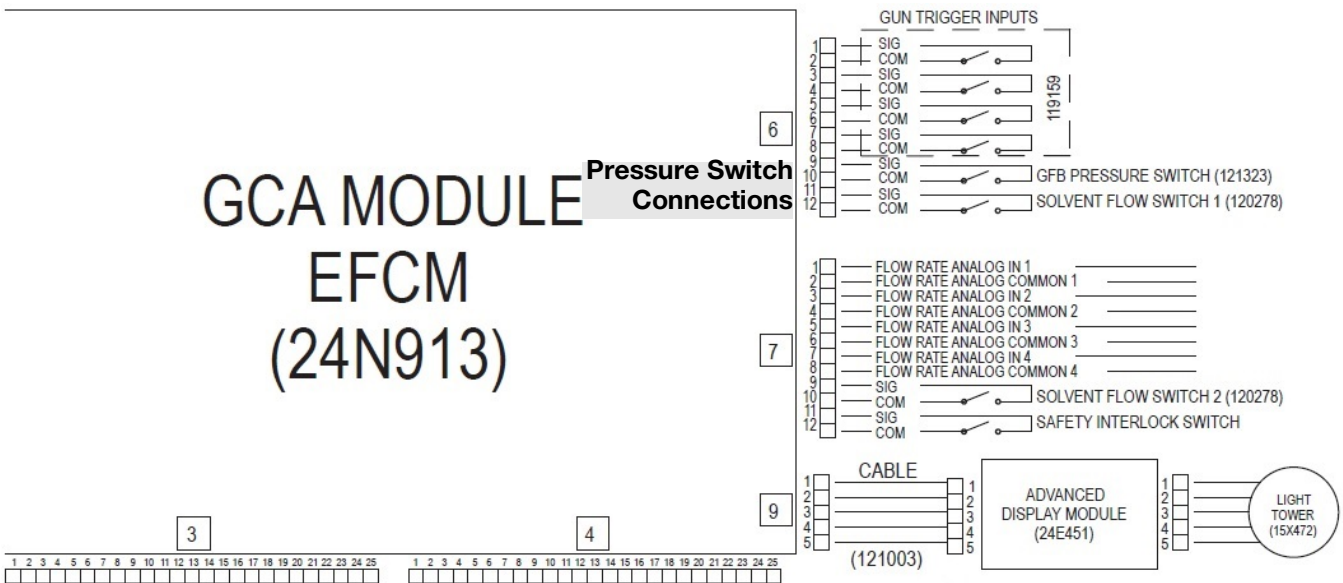
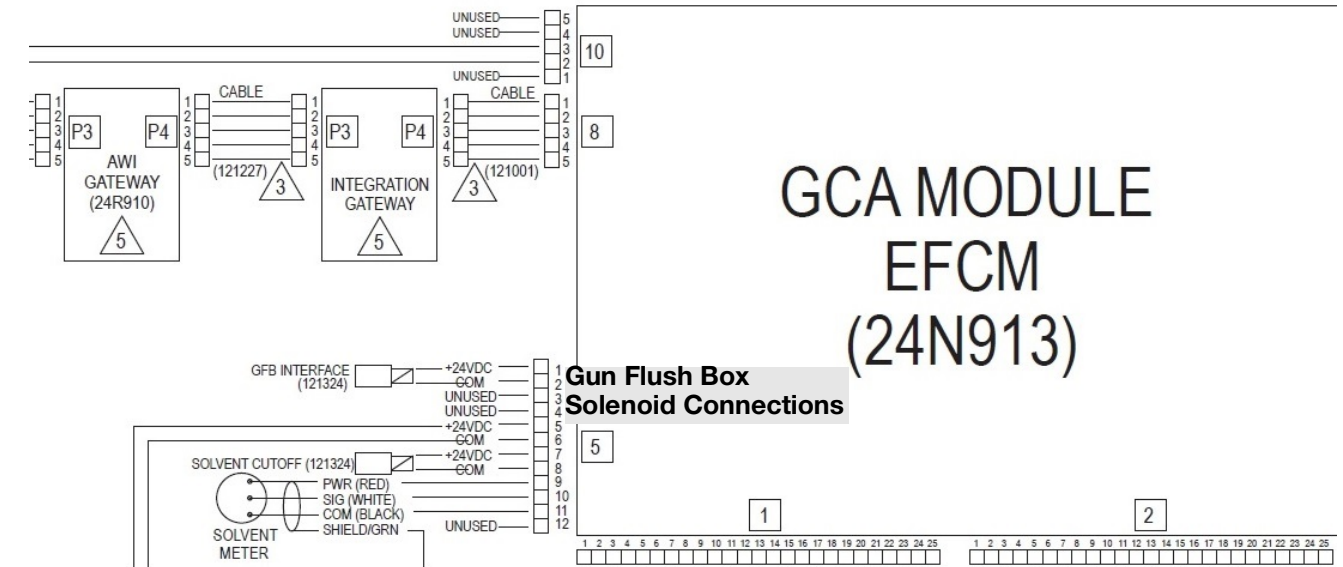

FIG. 21: System Electrical Schematic (ProMix PD2K)

Install the Atomizing Air Safety Shutoff Valve

1. Mount the safety shutoff valve securely.
2. Connect the gun atomizing air from the ProMix PD2K air flow switch to the safety shutoff valve IN port. See FIG. 13 and FIG. 24.
3. Connect an air line from the safety shutoff valve OUT port to the gun air inlet.

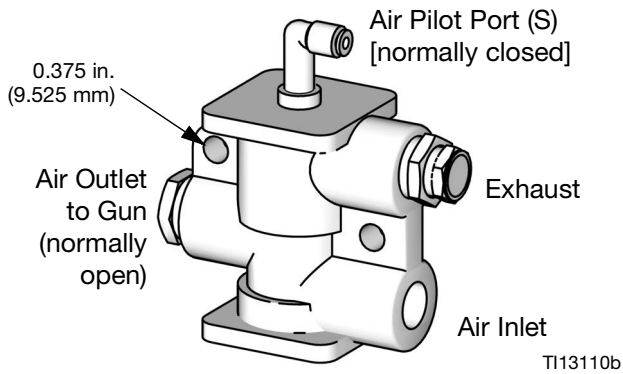

FIG. 22: Air Safety Shutoff Valve

Connect the Air Tubes to the Gun Flush Box

You must connect safety interlock air to prevent atomizing air from turning on during flushing.						

The four gun flush box air fittings are labeled as follows. See FIG. 23.

Label	Function
P	Gun flush box supply air input
A	Return air/pressure switch signal (sends air to the pressure switch when gun is ready for flushing or filling)
C	Gun trigger cylinders air (activates gun trigger for flushing or filling the gun)
S	Safety interlock (locks out atomizing air except when gun is ready to spray)

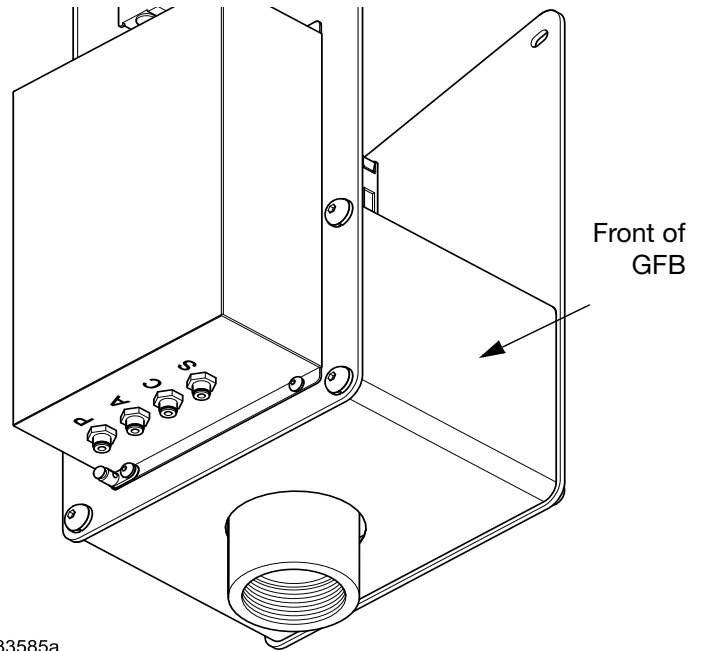

FIG. 23: Gun Flush Box Air Fittings (Bottom View)

NOTE: Use 5/32 in. (4 mm) OD tubing. Connect tubing as follows:

1. From the **P** fitting to the gun flush box solenoid (GFB, FIG. 24) output. Use a clean, dry air supply (filtered to 10 microns).
2. From the **A** fitting to the pressure switch air input (PS, FIG. 24).
3. From the **C** fitting to the air supply manifold (M, FIG. 24)
4. From the **S** fitting to the atomizing air safety shutoff valve pilot port (FIG. 22).

Trigger Height Adjustment

Adjust the trigger height to ensure the gun triggers during purging. See the Gun Flush Box manual 309227.

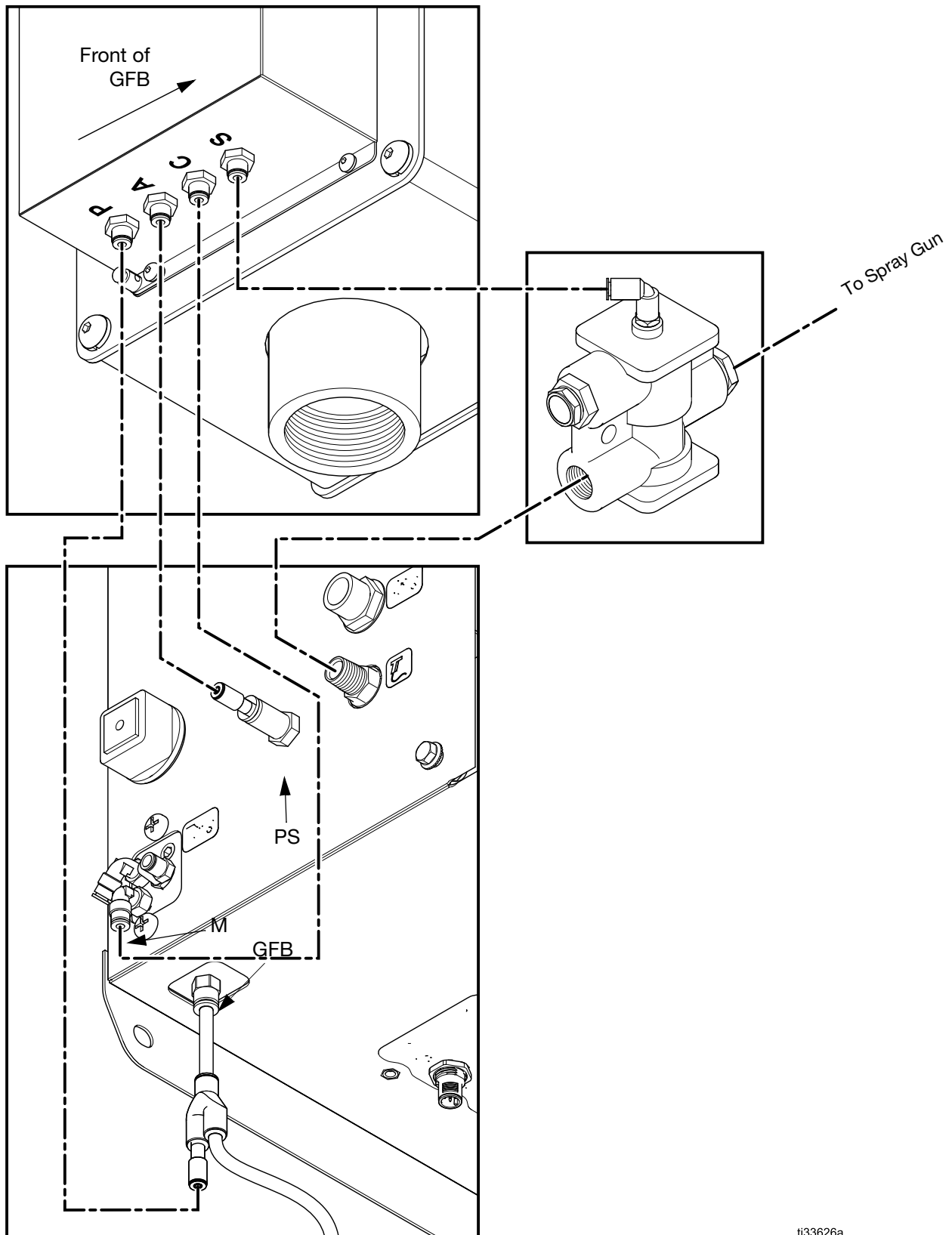

ti33626a

FIG. 24: GFB Solenoid, Air Manifold, Pressure Switch, and Air Flow Switch Connections (ProMix PD2K shown)

Operation

Follow the operating instructions in Gun Flush Box manual (309227) to use the Gun Flush Box.

Follow the operating instructions in the proportioner Operation manual to fill the gun with paint or to flush solvent through the gun.

See the following chart for a summary of GFB functions when used with a Graco proportioner.

GFB Lid	Gun in GFB?	Atomizing Air Status	Port A Pressure?	Port S Pressure?
Open	Yes	Locked out by safety shutoff valve	No	No
Open	No	Locked out by safety shutoff valve	No	No
Closed	Yes	Locked out by safety shutoff valve	Yes	No
Closed	No	Supplied to gun	No	Yes

Maintenance

	Daily	Weekly	Every 2 weeks, minimum
Gun Flush Box Enclosure	Clean the inside with a compatible solvent.	Clean the inside and outside with a compatible solvent.	
Door	Clean hinge holes.		Grease hinges.
Cylinders			Pull the cylinder rod forward and coat with grease or petroleum jelly.
Switches			Clean and lubricate.
Fluid Outlet Tube		Check for buildup of mix material and replace if restricted.	

Troubleshooting

Problem	Cause	Solution
Gun is in gun flush box, but system will not purge or mix.	Air is shut off.	Turn on system air.
	Gun switch is not activating.	Test switch. Replace if damaged.
	Pressure switch is not working properly.	Check that correct fluid station circuit board input is activating (LED should be lit).
	Tubing is not installed correctly.	Check tubing connections, page 16 and page 25.
Gun flush box fails to purge after pot life time ends.	Gun is not in gun flush box.	Place gun in gun flush box when it is not in use.
	Gun switch is not activating.	Test switch. Replace if damaged.
Gun trigger does not trigger when gun flush box controller activates it.	Tubing is not installed correctly.	Check tubing connections, page 16 and page 25.
	Cylinder is dirty or damaged.	Clean cylinder rod or replace.
	Gun is not properly set in gun holder.	Check to make sure gun holder is not obstructed by buildup.
	Lower cylinder is out of adjustment.	Adjust cylinder block. See Trigger Height Adjustment , page 15 and page 24.
Gun is out of gun flush box with door closed but atomizing air is off.	Lid switch or gun switch failure.	Check switches and replace if necessary.
	No air flow to gun flush box.	Check air supply and tubing.

Parts

Part No. 15V826 Gun Flush Box Kit

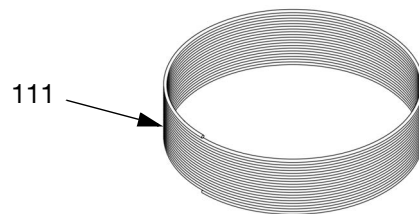
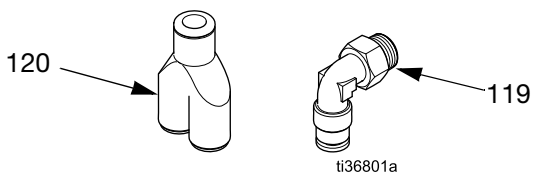
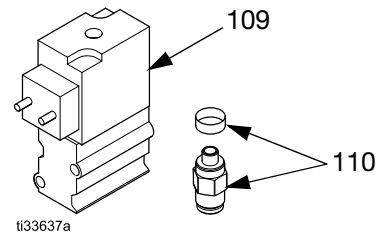
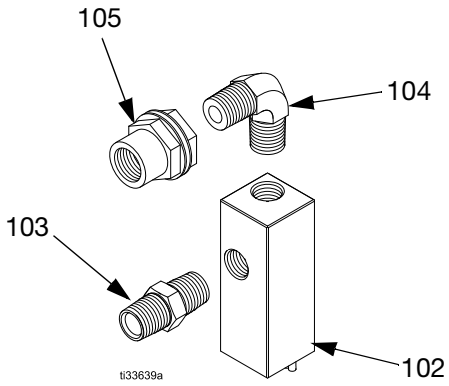
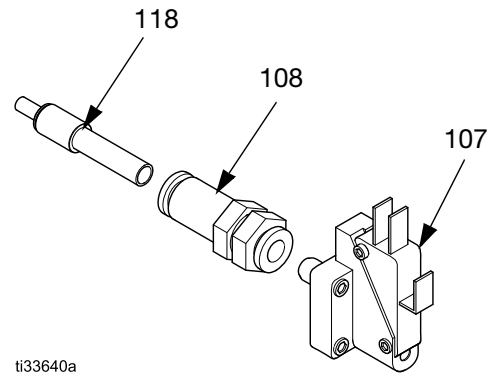
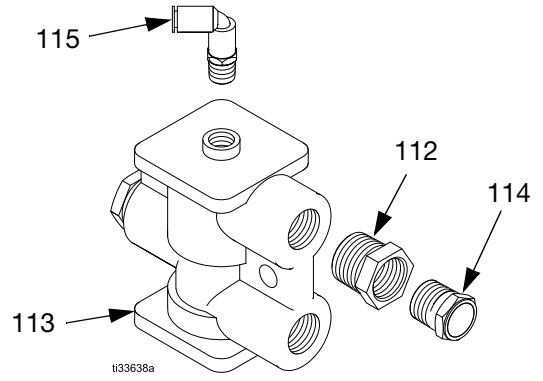
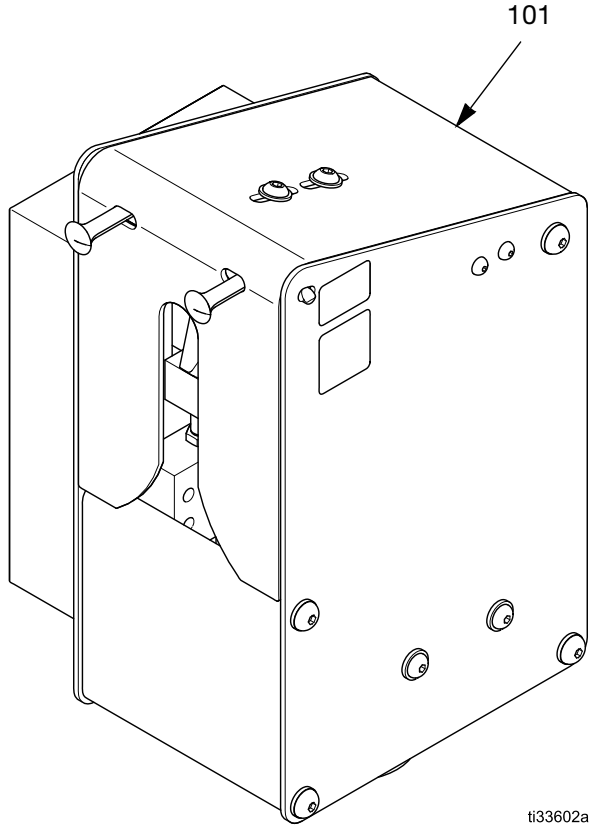

Part No. 15V826 Gun Flush Box Kit

Ref. No.	Part No.	Description	Qty.
101	244105	MODULE, gun flush box, see manual 309227	1
102◆	119159	SWITCH, air flow	1
103◆	113029	NIPPLE; 1/4 npt	1
104◆	111763	ELBOW; 1/4 npt (mbe)	1
105◆	104641	FITTING, bulkhead; 3/4-20 unef x 1/4 npt(f)	1
107	121323	SWITCH, pressure	1
108	104176	BULKHEAD; 1/4 in. (6 mm) OD tube x 1/4 in. (6 mm) OD tube	1
109	121324	VALVE, solenoid	1
110	111328	CONNECTOR; 10-32 x 5/32 in. (4 mm) OD tube	1
111	598095	TUBE, air, nylon; 5/32 in. (4 mm) OD; for making air connections; must be ordered in 500 ft (152.5 m) lengths	1
112‡	100081	BUSHING; 1/2 npt(m) x 3/8 npt(f)	1
113‡	104632	VALVE, piloted	1
114‡	111881	MUFFLER	1
115‡	598140	ELBOW, tube; 1/8 npt(m) x 5/32 in. (4 mm) OD tube	1
118	517312	ADAPTER, tube; 1/4 in. (6 mm) OD tube x 5/32 in. (4 mm) OD tube	2
119	114151	FITTING, elbow, male; 1/8 npt, 5/32 tube	1
120	115287	FITTING, tube, y; 1/4"	1

◆ *Part of Air Flow Switch Kit 15T632.*

‡ *Part of Atomizing Air Safety Shutoff Kit 15V823.*

Accessories

Gun Holder

Part No.	Description
198405	Graco Pro™ Xs3, Pro™ Xs4
198787	Graco Pro™ Xs2
196769	Graco Delta Spray™ Gun
196770	Graco Alpha Gun
196771	Graco Alpha Plus, Alpha Plus with RAC Tip
196767	Devilbiss JGA/MSA*
15T646	Graco AirPro™ Gun
15G093	Graco G15 AA Gun
15G346	Graco G40 AA Gun
24N528 ‡	Graco Pro Xp™ 60 & 85 kV Gun
24N529	Graco Pro Xp™ 40 kV Gun

* Brand names or marks are used for identification purposes and are trademarks of their respective owners.

‡ Includes yoke.

Graco Pro Xp™ 60 & 85 kV Gun Insertion Operation with 24N528

1. Rotate the gun clockwise and insert the gun into the holder.

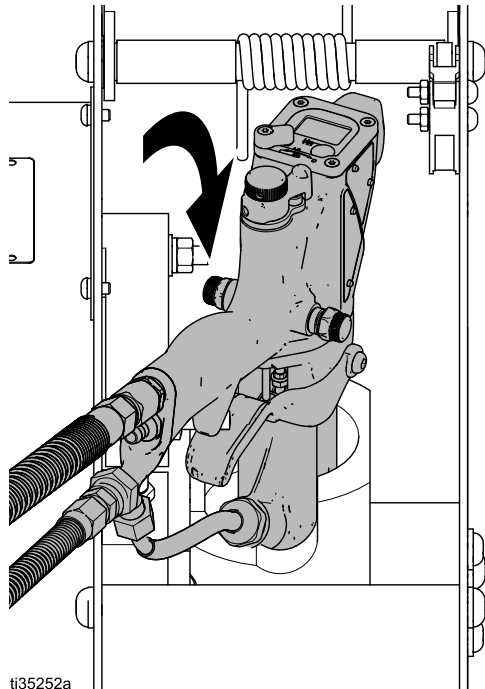
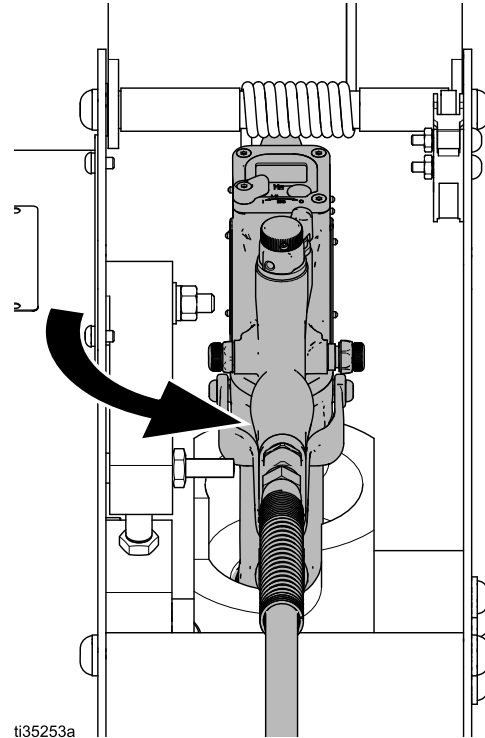

FIG. 25: ti35252a

2. After the gun is seated, rotate the gun counter-clockwise so the lid can be closed.



ti35253a

FIG. 26:

570123 Wall Mount Kit

For mounting the Gun Flush Box to the spray booth wall. Kit mounts only to the right side of the Gun Flush Box.

Technical Data

Maximum Air Inlet Pressure	100 psi (0.7 MPa, 7 bar)
Minimum Air Flow required to activate Air Flow Switch . .	1 cfm (28.3 lpm, 0.028 m ³ /min)
Weight	22 lbs. (9.6 kg)
Height	14 in. (356 mm)
With door open	21 in. (533 mm)
Width	7 in. (178 mm)
Length	11 in. (279 mm)
Outlet	2 in. npt(f)
Wetted Parts	Stainless steel, nylon, ultra high molecular weight polyethylene

Graco Standard Warranty

Graco warrants all equipment referenced in this document which is manufactured by Graco and bearing its name to be free from defects in material and workmanship on the date of sale to the original purchaser for use. With the exception of any special, extended, or limited warranty published by Graco, Graco will, for a period of twelve months from the date of sale, repair or replace any part of the equipment determined by Graco to be defective. This warranty applies only when the equipment is installed, operated and maintained in accordance with Graco's written recommendations.

This warranty does not cover, and Graco shall not be liable for general wear and tear, or any malfunction, damage or wear caused by faulty installation, misapplication, abrasion, corrosion, inadequate or improper maintenance, negligence, accident, tampering, or substitution of non-Graco component parts. Nor shall Graco be liable for malfunction, damage or wear caused by the incompatibility of Graco equipment with structures, accessories, equipment or materials not supplied by Graco, or the improper design, manufacture, installation, operation or maintenance of structures, accessories, equipment or materials not supplied by Graco.

This warranty is conditioned upon the prepaid return of the equipment claimed to be defective to an authorized Graco distributor for verification of the claimed defect. If the claimed defect is verified, Graco will repair or replace free of charge any defective parts. The equipment will be returned to the original purchaser transportation prepaid. If inspection of the equipment does not disclose any defect in material or workmanship, repairs will be made at a reasonable charge, which charges may include the costs of parts, labor, and transportation.

THIS WARRANTY IS EXCLUSIVE, AND IS IN LIEU OF ANY OTHER WARRANTIES, EXPRESS OR IMPLIED, INCLUDING BUT NOT LIMITED TO WARRANTY OF MERCHANTABILITY OR WARRANTY OF FITNESS FOR A PARTICULAR PURPOSE.

Graco's sole obligation and buyer's sole remedy for any breach of warranty shall be as set forth above. The buyer agrees that no other remedy (including, but not limited to, incidental or consequential damages for lost profits, lost sales, injury to person or property, or any other incidental or consequential loss) shall be available. Any action for breach of warranty must be brought within two (2) years of the date of sale.

GRACO MAKES NO WARRANTY, AND DISCLAIMS ALL IMPLIED WARRANTIES OF MERCHANTABILITY AND FITNESS FOR A PARTICULAR PURPOSE, IN CONNECTION WITH ACCESSORIES, EQUIPMENT, MATERIALS OR COMPONENTS SOLD BUT NOT MANUFACTURED BY GRACO. These items sold, but not manufactured by Graco (such as electric motors, switches, hose, etc.), are subject to the warranty, if any, of their manufacturer. Graco will provide purchaser with reasonable assistance in making any claim for breach of these warranties.

In no event will Graco be liable for indirect, incidental, special or consequential damages resulting from Graco supplying equipment hereunder, or the furnishing, performance, or use of any products or other goods sold hereto, whether due to a breach of contract, breach of warranty, the negligence of Graco, or otherwise.

FOR GRACO CANADA CUSTOMERS

The Parties acknowledge that they have required that the present document, as well as all documents, notices and legal proceedings entered into, given or instituted pursuant hereto or relating directly or indirectly hereto, be drawn up in English. Les parties reconnaissent avoir convenu que la rédaction du présente document sera en Anglais, ainsi que tous documents, avis et procédures judiciaires exécutés, donnés ou intentés, à la suite de ou en rapport, directement ou indirectement, avec les procédures concernées.

Graco Information

For the latest information about Graco products, visit www.graco.com.

For patent information, see www.graco.com/patents.

All written and visual data contained in this document reflects the latest product information available at the time of publication. Graco reserves the right to make changes at any time without notice.

Original instructions. This manual contains English. MM 312784

Graco Headquarters: Minneapolis

International Offices: Belgium, China, Japan, Korea

GRACO INC. AND SUBSIDIARIES • P.O. BOX 1441 • MINNEAPOLIS MN 55440-1441 • USA
Copyright 2008, Graco Inc. All Graco manufacturing locations are registered to ISO 9001.

www.graco.com
Revision J, February 2024