

# Proportioning Pumps

312068U

EN

***Proportioning pumps and hydraulic cylinders used on hydraulic proportioners. For professional use only.***

**Not approved for use in European explosive atmosphere locations.**



## **Important Safety Instructions**

Read all warnings and instructions in this manual and all supplied manuals before operating the equipment. Save these instructions.

*Model 247576: 2000 psi (13.8 MPa, 138 bar) Maximum Working Pressure*

*All other models: 3500 psi (24.0 MPa, 240 bar) Maximum Working Pressure*

See page 2 for model information.

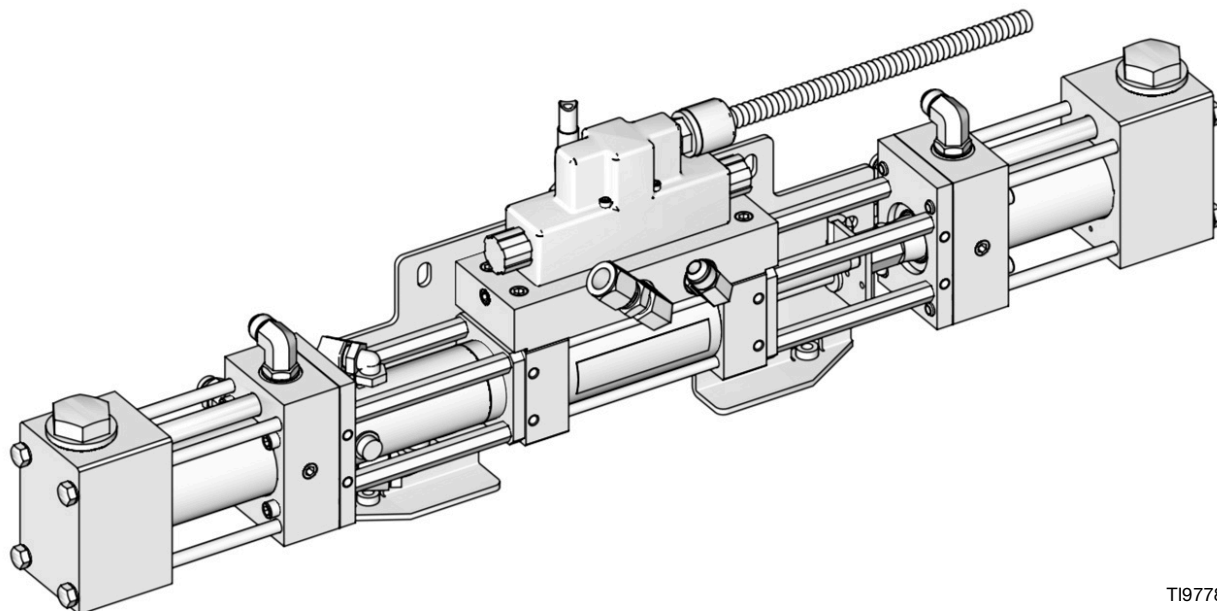

T19778d

# Contents

**Models** ..... 2

    Proportioning Pumps ..... 2

    Hydraulic Cylinders ..... 2

    Pumplines ..... 2

    In-Plant Pumpline ..... 2

**Warnings** ..... 3

**Repair** ..... 6

    Flushing ..... 6

    Pressure Relief Procedure ..... 6

    Preventive Maintenance ..... 6

    Pumpline Disassembly ..... 7

    Pumpline Reassembly ..... 7

    Pump Base Disassembly ..... 9

    Pump Base Reassembly ..... 9

    Piston and Cylinder Seals ..... 10

    Hydraulic Cylinder ..... 12

**Parts** ..... 18

    Pumpline ..... 18

    Piston and Cylinder Seals ..... 20

    Hydraulic Cylinder ..... 22

**Technical Specifications** ..... 25

**Graco Standard Warranty** ..... 26

# Models

## Proportioning Pumps

Part, Series	Cylinder Size
24F291, A	#28
247371, A	#30
247372, A	#40
247373, A	#48
247374, A	#60
247375, A	#80
247577, A	#88
247376, A	#96
247377, A	#120
247576, A	#140

## Hydraulic Cylinders

Part, Series
295027

## Pumplines

Part, Series	Cylinder Size
288638	#80
288639	#120

## In-Plant Pumpline





Part, Series	Cylinder Size
P7758-255773	#80

# Warnings

The following warnings are for the setup, use, grounding, maintenance, and repair of this equipment. The exclamation point symbol alerts you to a general warning and the hazard symbols refer to procedure-specific risks. When these symbols appear in the body of this manual or on warning labels, refer back to these Warnings. Product-specific hazard symbols and warnings not covered in this section may appear throughout the body of this manual where applicable.

 <span style="font-size: 2em; font-weight: bold; margin-left: 10px;">WARNING</span>	
	<p><b>SKIN INJECTION HAZARD</b></p> <p>High-pressure fluid from dispensing device, hose leaks, or ruptured components will pierce skin. This may look like just a cut, but it is a serious injury that can result in amputation. Get immediate surgical treatment.</p> <ul style="list-style-type: none"> <li>• Engage trigger lock when not dispensing.</li> <li>• Do not point dispensing device at anyone or at any part of the body.</li> <li>• Do not put your hand over the fluid outlet.</li> <li>• Do not stop or deflect leaks with your hand, body, glove, or rag.</li> <li>• Follow the Pressure Relief Procedure when you stop dispensing and before cleaning, checking, or servicing equipment.</li> <li>• Tighten all fluid connections before operating the equipment.</li> <li>• Check hoses and couplings daily. Replace worn or damaged parts immediately.</li> </ul>
	<p><b>FIRE AND EXPLOSION HAZARD</b></p> <p>Flammable fumes, such as solvent and paint fumes, in <b>work area</b> can ignite or explode. Paint or solvent flowing through the equipment can cause static sparking. To help prevent fire and explosion:</p> <ul style="list-style-type: none"> <li>• Use equipment only in well ventilated area.</li> <li>• Eliminate all ignition sources; such as pilot lights, cigarettes, portable electric lamps, and plastic drop cloths (potential static sparking).</li> <li>• Ground all equipment in the work area. See <b>Grounding</b> instructions in related manuals.</li> <li>• Never spray or flush solvent at high pressure.</li> <li>• Keep work area free of debris, including solvent, rags and gasoline.</li> <li>• Do not plug or unplug power cords, or turn power or light switches on or off when flammable fumes are present.</li> <li>• Use only grounded hoses.</li> <li>• Hold gun firmly to side of grounded pail when triggering into pail. Do not use pail liners unless they are anti-static or conductive.</li> <li>• <b>Stop operation immediately</b> if static sparking occurs or you feel a shock. Do not use equipment until you identify and correct the problem.</li> <li>• Keep a working fire extinguisher in the work area.</li> </ul>

# **WARNING**

 	<p><b>EQUIPMENT MISUSE HAZARD</b></p> <p>Misuse can cause death or serious injury.</p> <ul style="list-style-type: none"> <li>• Do not operate the unit when fatigued or under the influence of drugs or alcohol.</li> <li>• Do not exceed the maximum working pressure or temperature rating of the lowest rated system component. See <b>Technical Specifications</b> in all equipment manuals.</li> <li>• Use fluids and solvents that are compatible with equipment wetted parts. See <b>Technical Specifications</b> in all equipment manuals. Read fluid and solvent manufacturer’s warnings. For complete information about your material, request Safety Data Sheet (SDS) from distributor or retailer.</li> <li>• Do not leave the work area while equipment is energized or under pressure.</li> <li>• Turn off all equipment and follow the <b>Pressure Relief Procedure</b> when equipment is not in use.</li> <li>• Check equipment daily. Repair or replace worn or damaged parts immediately with genuine manufacturer’s replacement parts only.</li> <li>• Do not alter or modify equipment. Alterations or modifications may void agency approvals and create safety hazards.</li> <li>• Make sure all equipment is rated and approved for the environment in which you are using it.</li> <li>• Use equipment only for its intended purpose. Call your distributor for information.</li> <li>• Route hoses and cables away from traffic areas, sharp edges, moving parts, and hot surfaces.</li> <li>• Do not kink or over bend hoses or use hoses to pull equipment.</li> <li>• Keep children and animals away from work area.</li> <li>• Comply with all applicable safety regulations.</li> </ul>
 	<p><b>MOVING PARTS HAZARD</b></p> <p>Moving parts can pinch, cut, or amputate fingers and other body parts.</p> <ul style="list-style-type: none"> <li>• Keep clear of moving parts.</li> <li>• Do not operate equipment with protective guards or covers removed.</li> <li>• Pressurized equipment can start without warning. Before checking, moving, or servicing equipment, follow the <b>Pressure Relief Procedure</b> and disconnect all power sources.</li> </ul>
	<p><b>BURN HAZARD</b></p> <p>Equipment surfaces and fluid that is heated can become very hot during operation. To avoid severe burns:</p> <ul style="list-style-type: none"> <li>• Do not touch hot fluid or equipment.</li> </ul>



# WARNING



## TOXIC FLUID OR FUMES HAZARD

Toxic fluids or fumes can cause serious injury or death if splashed in the eyes or on skin, inhaled or swallowed.

- Read Safety Data Sheet (SDS) for handling instructions and to know the specific hazards of the fluids you are using, including the effects of long-term exposure.
- When spraying, servicing equipment, or when in the work area, always keep work area well ventilated and always wear appropriate personal protective equipment. See **PERSONAL PROTECTIVE EQUIPMENT** warnings in this manual.
- Store hazardous fluid in approved containers, and dispose of it according to applicable guidelines.





## PERSONAL PROTECTIVE EQUIPMENT

Always wear appropriate personal protective equipment and cover all skin when spraying, servicing equipment, or when in the work area. Protective equipment helps prevent serious injury, including long-term exposure; inhalation of toxic fumes, mists or vapors; allergic reaction; burns; eye injury and hearing loss. This protective equipment includes but is not limited to:

- A properly fitting respirator, which may include a supplied-air respirator, chemically impermeable gloves, protective clothing and foot coverings as recommended by the fluid manufacturer and local regulatory authority.
- Protective eyewear and hearing protection.

# Repair

## Flushing

				
<p>To avoid fire and explosion, always ground equipment and waste container. To avoid static sparking and injury from splashing, always flush at the lowest possible pressure.</p> <p>Hot solvent may ignite. To avoid fire and explosion:</p> <ul style="list-style-type: none"> <li>• Flush equipment only in a well-ventilated area</li> <li>• Ensure main power is off and heater is cool before flushing</li> <li>• Do not turn on heater until fluid lines are clear of solvent</li> </ul>				

- Flush out old fluid with new fluid, or flush out old fluid with a compatible solvent before introducing new fluid.
- To flush entire system, circulate through gun fluid manifold (with manifold removed from gun).
- Always leave some type of fluid in system. Do not use water.

## Pressure Relief Procedure

 Follow the Pressure Relief Procedure whenever you see this symbol.

				
				
<p>This equipment stays pressurized until pressure is manually relieved. To help prevent serious injury from pressurized fluid, such as skin injection, splashing fluid and moving parts, follow the Pressure Relief Procedure when you stop dispensing and before cleaning, checking, or servicing the equipment.</p>				

1. Select **Park** on Pump Control Switch if available, or turn off.
2. Turn off feed pumps.
3. Trigger gun to relieve pressure.
4. Close gun inlet valves.
5. Close fluid supply inlet valves.
6. Service spray gun. See corresponding spray gun manual.

## Preventive Maintenance

When pumps are functioning properly, it is not unusual for a trace amount of resin to seep past the pump packing onto the resin pump shaft. Routinely inspect shaft and wipe away any residue when the proportioner is turned off. Disassemble and clean the proportioning pumps annually.

For pumpline P7758-255773, disassemble and clean the proportioning pumps every six months. Inspect the pistons and cylinder for marks or scratches, which may cause leakage and damage to packings. Replace all packings, o-rings, and bushings annually.

For pumpline P7758-255773, replace these items every six months.

## Pumpline Disassembly

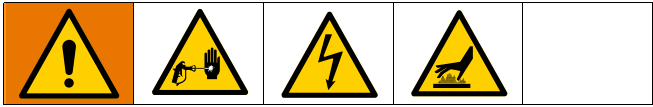

1. Remove plug fitting (206) from lube cylinder (205).
2. Insert clevis pin removal tool 296607 through opening in lube cylinder (205) and screw tool into left clevis pin (219). Pull the clevis pin out of clevis (117).
3. Use hex key to remove four socket head cap screws (203) from left proportioning pump (202). Remove left proportioning pump.
4. Remove lube cylinder (205).
5. Screw pin removal tool 296607 into right clevis pin (219). Pull clevis pin out of clevis (117).
6. Use hex key to remove four socket head cap screws (203) on right proportioning pump (202). Remove right proportioning pump.

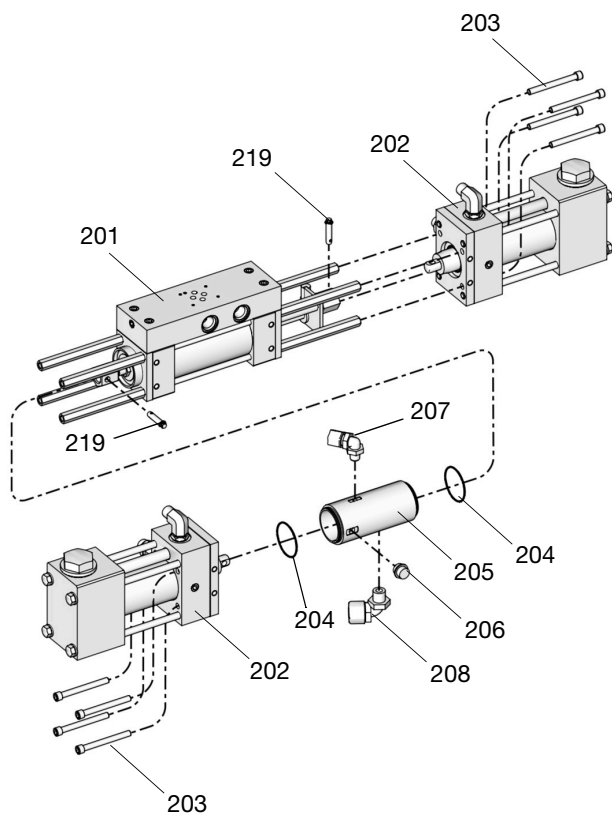

## Pumpline Reassembly

1. Slide the hydraulic piston (104) in the hydraulic cylinder (201) out to its left-most position. The left end of the left clevis (117) should be nearly in line with the left end of the spacers (113). See the following image.

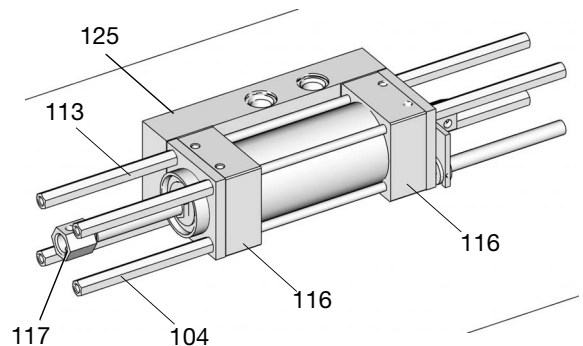

2. Place hydraulic cylinder (201) on flat surface with both the manifold (125) and the port blocks (116) contacting the surface. The two main ports in the manifold should be facing up. See the following image.

3. Install elbow fittings (207, 208) into lube cylinder (206) and install lube cylinder over left clevis (117). Ensure clevis pin hole in lube cylinder is vertical, in line with the hole in the left clevis.

4. Place left proportioning pump (202) on flat surface with the wide end of the outlet flange (26) facing down.

5. Use clevis pin removal tool 296607 to slide the proportioning pump piston rod (28) out to its limit. Ensure the hole in the proportioning pump shaft is vertical, in line with the hole in the left clevis and lube cylinder.

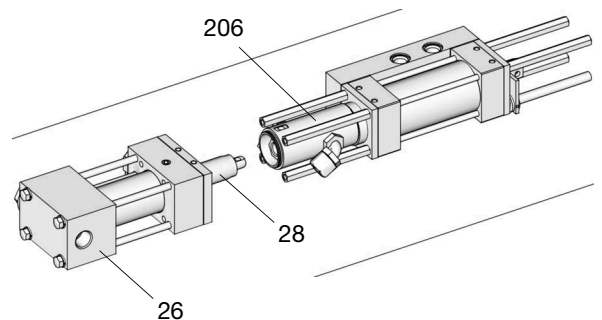

## Repair

6. Attach the clevis pin (219) to the clevis pin tool. Insert clevis pin through hole in lube cylinder and into the left clevis.
7. Gently tap end of clevis pin tool with hammer to slide clevis pin (219) into place. Remove clevis pin tool from clevis pin.
8. Insert four hex head cap screws (203) through holes in proportioning pump (202) and partially screw into spacers (113) in hydraulic cylinder (201).
9. With the four hex head cap screws in place but not tightened, slide the proportioning pump against the hydraulic cylinder.
10. Clamp the hydraulic cylinder and proportioning pump assembly to the flat surface so the proportioning pump and hydraulic cylinder will not twist when tightened against each other.
11. Tighten the hex head cap screws in a criss-cross pattern.
12. Repeat steps 4-11 with the right proportioning pump.
13. Install plug fitting (206) into lube cylinder (205).



## Pump Base Disassembly

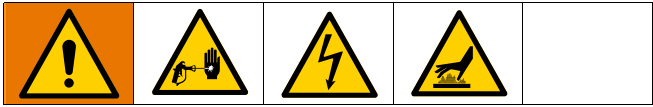

Disassemble and clean pump base annually. For pumpline P7758-255773, disassemble and clean the pump base on every six months.

1. Follow the **Pressure Relief Procedure**, page 6.
2. Turn OFF the main disconnect and lock out power at the source.
3. Remove pump cap (19) from pump base (23), and remove o-ring (6):
  - a. Remove outlet ball (4) and o-ring (9).
  - b. Remove inlet ball cage (14), spring (22) and inlet ball (10).
  - c. Remove inlet ball seat (11) and o-ring (9) from bottom of cavity.

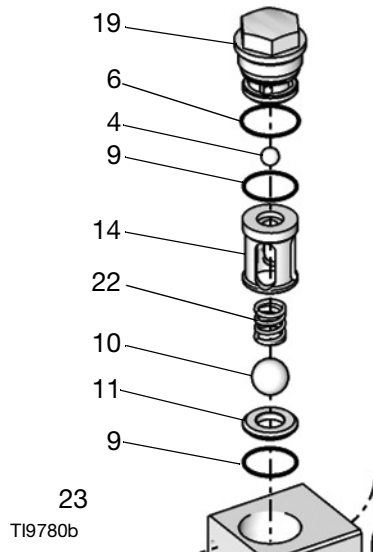

- d. Thoroughly clean all metal parts in a compatible solvent and inspect for wear or damage. Inspect each ball and seat for nicks or scratches; replace as required.
- e. Replace all o-rings. Kit 261859 contains all o-rings for pump base rebuild.

## Pump Base Reassembly

1. Install inlet valve in pump base by inserting o-ring (9), inlet ball seat (11), ball (10), spring (22), and inlet ball cage (14) into pump base cavity. See **Parts** on page 18.
2. Install outlet valve in pump base:
  - a. Install o-ring (9) and valve ball (4) into the cavity.
  - b. Install the o-ring (6) on pump cap (19). Install and tighten cap to pump base. Torque to 75 ft-lb (101.3 N•m).

## Piston and Cylinder Seals



**NOTE:** Piston Seal and Cylinder Seal Repair Kits are available. See Table 1 on page 21 to order the correct kits for your pump. Also see kit manual 312071.

### Disassembly

1. Follow the **Pressure Relief Procedure**, page 6.
2. Turn OFF the main disconnect and lock out power at the source.
3. Disconnect the pump inlet and outlet lines; see your proportioner repair manual. Remove the four screws (30) holding the pump outlet flange (26) to the hydraulic cylinder. Disconnect pump from drive and take pump assembly to a workbench.
4. Remove the four bolts (8) and washers (5). See **Parts** on page 18.
5. Remove the flange retainer (27), gasket (17), bushing (13), and throat seal (29).
6. Use a soft-faced mallet to help separate pump base (23) and outlet flange (26) from cylinder (12). Remove crossover tube (24)
7. Remove piston from cylinder bore. Remove piston cap bolt (25), then slide bushing (18) and u-cup seal (15) from rod.
8. Thoroughly clean all parts in a compatible solvent and inspect for wear or damage. Replace as required.

### Reassembly

<b>NOTICE</b>
To prevent cross-contamination of the equipment's wetted parts, <b>never</b> interchange component A (isocyanate) and component B (resin) parts.

1. Install piston rod seal (15); ensure u-cup faces piston rod (28) as shown in FIG. 1.

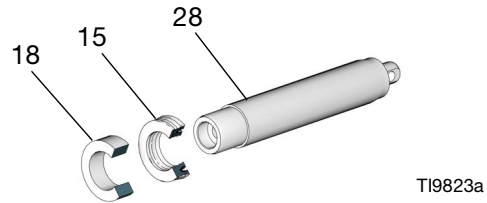

**FIG. 1: U-Cup Orientation**

2. Assemble piston bolt (25) to piston rod (28). Apply supplied thread sealant to piston bolt and tighten. See Torque Specification table for torque according to pump size.

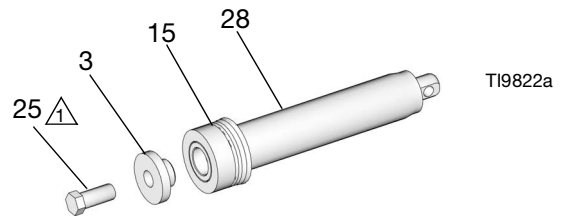

△ Apply supplied sealant to threads.

#### #28 Pump Size

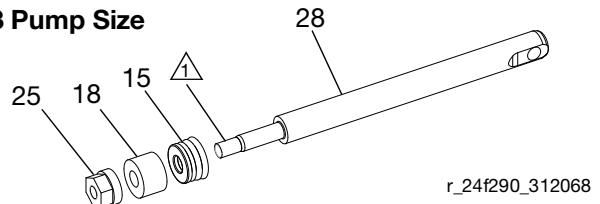
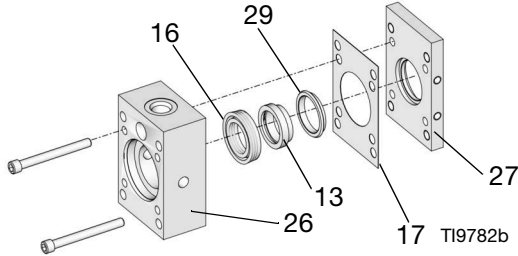

**FIG. 2: Piston Head and Rod**

#### Torque Specification

Pump Size	Torque
30	130 in-lb (14.7 N•m)
28, 40, 48, 60	22 ft-lb (29.7 N•m)
80, 88, 96, 120, 140	45 ft-lb (60.8 N•m)

- Using supplied bolts in the cylinder seal kits, press seal (16) into outlet flange (26). Ensure seal faces cylinder. Assemble bushing (13) throat seal (29) and gasket (17) into flange retainer (27) and fasten to outlet flange.



- Ensure plate is parallel with block. Carefully tighten screws until plate is flush with block. Be sure to press seal straight into bore.

Seal Alignment

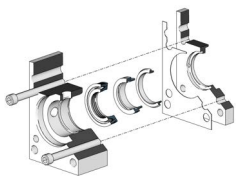

Pressed Seal

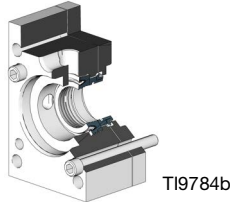

- Insert piston rod (28) through throat seal (29) on front of block. Use grease to aid with insertion if needed.

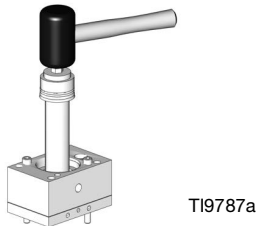

- Place assembly in a vise, and tap piston rod (28) through throat seal (29) and bearing.

**NOTICE**

Keep rod straight to prevent damage to throat seal.

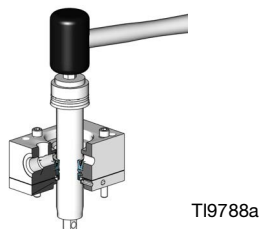

- Lubricate and assemble o-rings (1) to cylinder (12).
- Tap cylinder (12) onto piston rod (28) as shown in the following figure. Be careful to not score piston seal. Continue tapping cylinder until it seats in bore of outlet flange (26).

**NOTE:** Use grease to aid in insertion of cylinder onto piston rod.

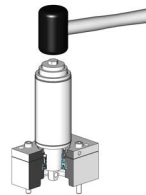

Cylinder Assembly

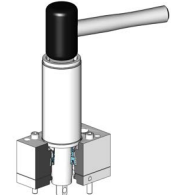

Seat Cylinder in Bore

- Lubricate and assemble o-rings (2) to crossover tube (24). Insert crossover tube into outlet flange (26). Softly tap crossover tube into bore until it seats.

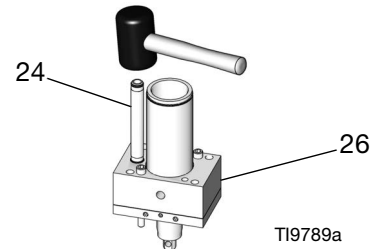

- Carefully align cylinder (12) and crossover tube (24) to bores in pump base (23). Tap pump base until the cylinder is fully seated in bore.

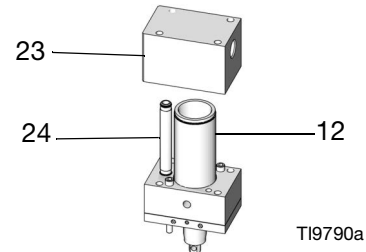

- Install four bolts (8) and washers (5). Torque to 45 ft-lb (60.8 N•m).

## Hydraulic Cylinder

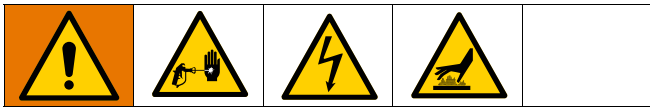

**NOTE:** For repairs, order Hydraulic Cylinder Repair Kit 296785.

### Disassembly

#### Tools Required

- Two - 1 in. open-end wrench
- Two - 1/2 in. open-end wrench
- O-ring pick

1. Follow the **Pressure Relief Procedure**, page 6.
2. Turn OFF the main disconnect and lock out power at the source.
3. Clamp the hydraulic cylinder to a flat surface using c-clamps or another strong clamping device, ensuring that the cylindrical spacer (114) is to the right.

#### NOTICE

Attach the clamps to the port blocks of the assembly. Attaching clamps to any other part of the assembly may result in significant damage when breaking loose the baffle jam nut and clevis.

4. Using the 1/2 in. open-end wrenches, loosen and remove four hexagonal spacers (113) to create room to rotate the clevises.

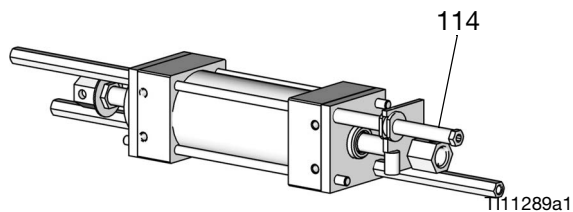

**NOTE:** The clevises and the baffle jam nut were installed with high strength thread sealant. The following steps will require significant force to break loose the baffle jam nut and clevises.

5. Using the 1 in. open-end wrench and the 1 in. impact wrench, rotate the baffle jam nut away from the right clevis until one of them breaks loose.

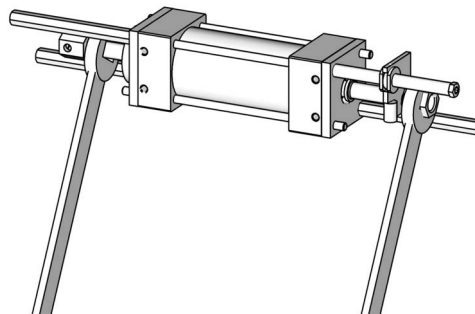

**If the left clevis and baffle jam nut break loose from the hydraulic piston shaft:**

6. Remove the clevis and baffle jam nut.
7. Remove the lubricator adapter (120).
8. Loosen and remove the remaining hex spacers (113) and smooth spacer (114), keeping the tie rods in place.
9. Remove the left retainer plate (101).
10. Remove the tie rods (115).
11. Remove the left port block and rod bushing assembly.
12. Slide the piston and everything attached to it out the right side of the cylinder by holding the assembly by the cylinder and pushing the left end of the piston shaft against a flat surface.
13. Using a c-clamp, secure the port block (116) of the remaining assembly.
14. Keeping the piston shaft from rotating using a 1/2 in. wrench on the piston shaft flats and using a 1 in. impact wrench on the right clevis, break loose and remove the right clevis.
15. Remove the activator plate (119) and modified bushing (118).
16. Remove the retainer plate (101).
17. Remove the right port block and rod bushing assembly.
18. Remove the rod bushings (103) from the port blocks (116).
19. Using the o-ring pick, remove all rings and seals.

### If the right clevis breaks loose from the hydraulic piston shaft:

6. Remove the right clevis.
7. Remove the activator plate (119) and modified bushing (118).
8. Remove the right retainer plate (101).
9. Remove the tie rods (115).
10. Remove the right rod bushing and port block assembly.
11. Slide the piston and everything attached to it out the left side of the cylinder by holding the assembly by the cylinder and pushing the right end of the piston shaft against a flat surface.
12. Using a c-clamp, secure the port block (116) of the remaining assembly.
13. Break the baffle jam nut (122) loose from the hydraulic piston shaft.
14. Keeping the piston shaft from rotating using a 1/2 in. wrench on the piston shaft flats and using a 1 in. impact wrench on the left clevis, break loose and remove the left clevis.
15. Remove the left retainer plate (101).
16. Remove the left port block and rod bushing assembly.
17. Remove the rod bushings (103) from the port block (116).
18. Using the o-ring pick, remove all rings and seals.

### Reassembly

#### Tools Required

- Torque wrench set to 15 ft-lb (20 N•m) with 1/2 in. socket attachment
- Torque wrench set to 40+/-5 ft-lb (54+/-6 N•m) with 13/16 in. open-end attachment
- 1 in. open-end wrench
- 1/2 in. open-end wrench

#### Assemble Rod Bushing to Port Block

1. Insert black o-ring (109) into the outside groove of rod bushing (103).
2. With the wide end of the rod bushing facing down, insert white back-up ring (110) above o-ring (109) in the same groove.
3. With the lip facing out, push one rod wiper (111) into the small end and one shaft seal (112) into the big end of the rod bushing.

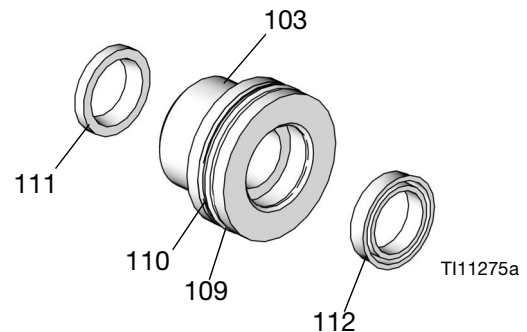

4. Place port block (116) on a flat surface with the large opening facing up.
5. Using your hands, push the wide end of the rod bushing into port block (116).
6. On the side opposite the rod bushing, place o-ring (105) around the extruding circle.

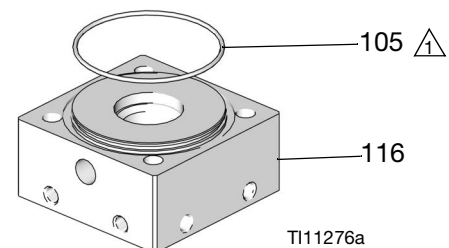

⚠ Apply lithium grease to o-ring.

7. Repeat the steps above to assemble the second rod bushing/port block assembly.

### Assemble Hydraulic Piston and Insert in Cylinder

8. Place wear ring (108) in the center channel of hydraulic piston (104).
9. With the lip facing away from the center channel, place one u-cup seal (106) in each of the remaining two channels of the hydraulic piston.
10. Place one back-up ring (107) in the same channel as each of the u-cup seals on the side facing the center channel.

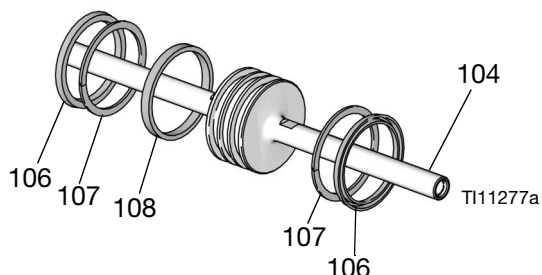

### Insert Piston into Cylinder

11. Slide the hydraulic piston into the cylinder (102). If necessary, rest the cylinder on a vise or similar surface while pushing the piston into it.

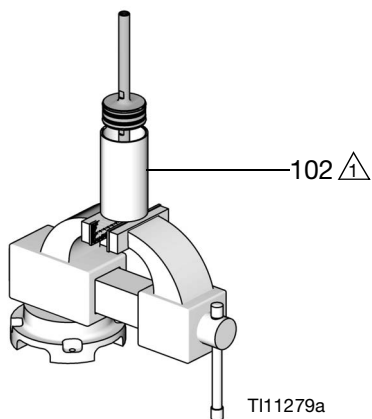

⚠ Apply lithium grease to the inside of each end of the cylinder.

### Assembling Items onto Piston Shaft

12. With the rod bushing (103) facing away from the cylinder (102), slide the port block and rod bushing assembly over the rod tool and onto the shaft.

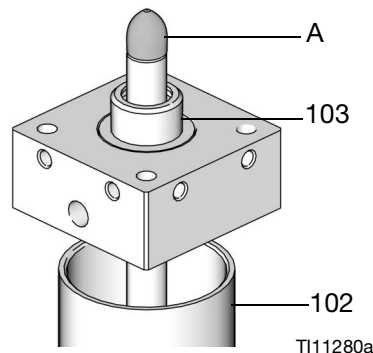

13. Repeat with the other port block on the opposite end of the hydraulic piston shaft.

### Attaching Retainer Plates and First Four Spacers

14. Place the assembly on a flat surface with the port hole on the two port blocks facing the same direction.
15. Slide one retainer plate over the end of each port block.
16. Insert one tie rod into each of the four holes in the port blocks and retainer plates. Keep an equal amount of threads showing through the retainer plate on each side.
17. Rotate the assembly so that the port holes are now facing in towards your body and place the assembly on a flat surface.

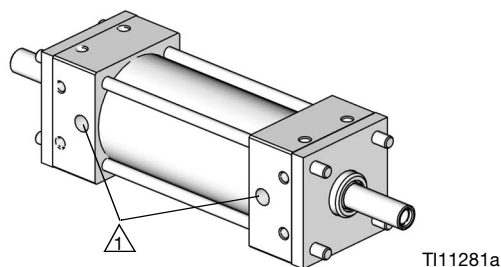

⚠ Make sure the port holes are facing in towards your

- Using the far, top tie-rod, attach cylindrical spacer (114) to the right side of the assembly.

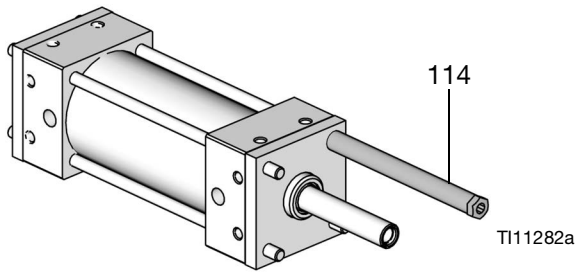

- Attach one hexagonal spacer (113) to the other end of the tie rod. Do not tighten.
- Attach one hexagonal spacer to each end of the bottom, near tie-rod. Do not tighten.

**NOTE:** In the following step, the port holes need to be facing down, with the cylindrical spacer (114) facing right.

- Secure the assembly to a flat surface using two c-clamps, or other strong clamping devices, to prevent the assembly from twisting. The assembly will remain secured to the flat surface for the remainder of the assembly procedure.
- With the assembly secured, torque the spacers against each other to 15 ft-lb (20 N•m).

### Installing Lube Adapter

- Push o-ring (121) into the inside groove of the cylinder lube adapter (120).

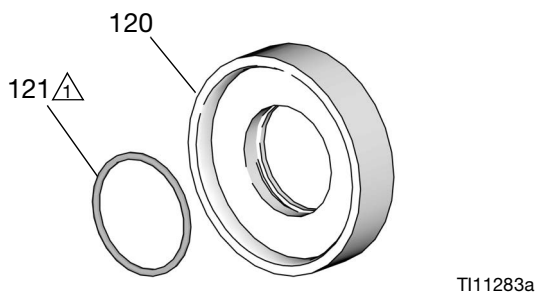

 Apply lithium grease to the o-ring.

- With the lip of the adapter facing left, slide the adapter onto the left end of the hydraulic piston shaft.

### Installing Hex Clevises and Baffle Jam Nut

- With the hex-side of the baffle jam nut facing away from the hex-head of the clevis, spin the baffle jam nut (122) onto the hex clevis (117). Leave one to two threads between the head of the clevis and the nut.

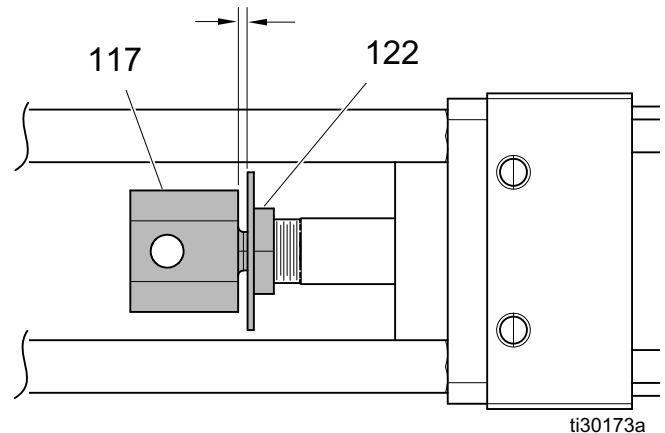

- Apply primer (123) to the threads with the thread sealant.
- Apply high strength thread sealant (124) to the threads of both hex clevises (117).
- Attach modified bushing (118) to the activator plate (119).
- Insert the clevis (117) without the baffle jam nut (122) into the corner hole of the activator plate (119).
- Slide the modified bushing over the cylindrical spacer (114) and screw the clevis (117) into the right end of the hydraulic piston shaft (104).
- Spin the clevis (117) and baffle jam nut (122) onto the left end of the hydraulic piston shaft finger-tight, ensuring a gap of one to two threads between the baffle jam nut and the head of the left clevis.

32. Rotate the right clevis until the cross-holes form a vertical line.

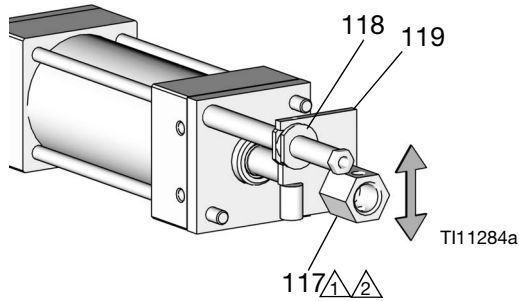

- ① Apply high strength thread sealant to threads of both hex clevises.
- ② Apply primer to the threads with the thread sealant to speed curing.

33. Hold the right clevis stationary with a 1 in. open-end wrench and, by turning the baffle jam nut with a 13/16 in. torque-wrench, torque the right clevis to 40+/-5 ft-lb (54+/-6 N•m) against the activator plate.

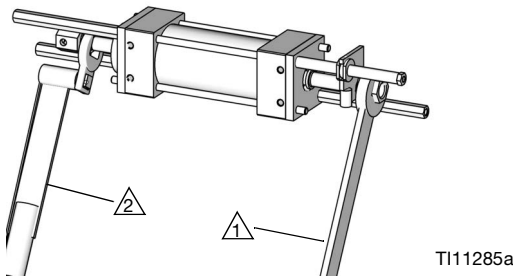

- ① Hold stationary.
- ② Rotate to torque the right clevis.

**NOTICE**

Do not over torque. Over torquing may strip the thread of the clevis or piston rod.

34. Hold the left clevis stationary with a 1 in. wrench and break the baffle jam nut loose from the hydraulic piston shaft.

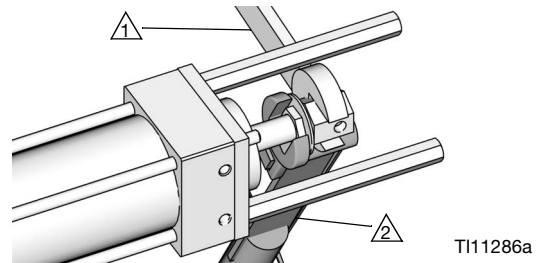

- ① Hold stationary.
- ② Rotate to break baffle jam nut loose from piston shaft.

**NOTICE**

Do not unscrew the left clevis more than necessary. An improperly adjusted clevis could damage the piston seal.

35. Hand tighten the left clevis (117) and baffle jam nut (122) so no gap exists between the clevis and baffle jam nut. Then hand tighten to the hydraulic piston shaft so no gap exists between the baffle jam nut and the hydraulic piston shaft.

36. Hold the baffle jam nut stationary and loosen the left clevis between one and two turns. Ensure that the cross-holes form a horizontal line. Do not back out more than two turns.

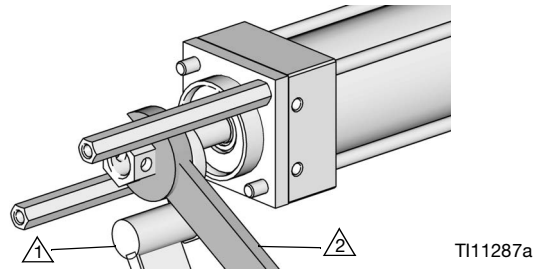

- ① Hold baffle jam nut stationary.
- ② Rotate to position cross-holes in a horizontal line.



**NOTICE**

In the following step, do not over torque. Over torquing may strip the thread of the clevis or piston rod.

37. Hold the left clevis stationary with a 1 in. open-end wrench to keep the cross-holes horizontal and torque the baffle jam nut against the hydraulic piston shaft to 40+/-5 ft-lb (54+/-6 N•m) using a torque wrench.

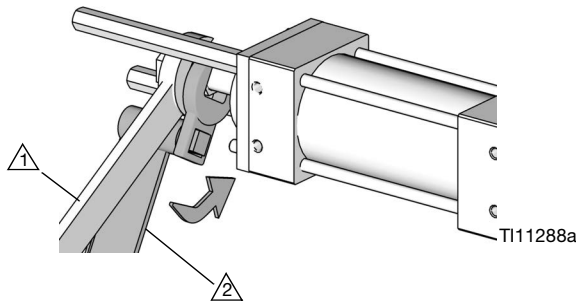

- 1 Hold stationary.
- 2 Rotate to torque the baffle jam nut to 40+/-5 ft-lb (54+/-6 N•m) against the hydraulic piston shaft, which torques the left clevis.

38. Double check that the left clevis cross-holes are horizontal and the right clevis cross-holes are vertical.

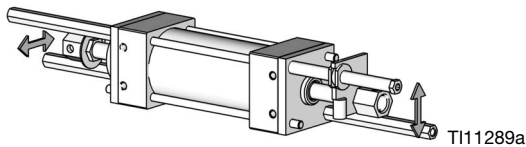

**Installing Final Four Spacers**

39. Preventing the tie rod (115) from spinning with one hand, spin one spacer (113) onto one end until it butts against the retainer plate (101). Repeat for opposite end of tie rod.

**Assembling Manifold**

40. Insert pipe plugs (127) into manifold (125).
41. Insert o-rings (128) into bottom holes of manifold.
42. With the port holes facing the manifold, attach the manifold to the port blocks using the four screws (126).

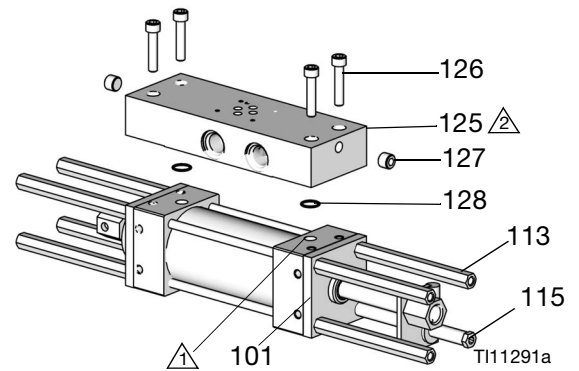

- 1 Have the port holes facing the manifold.
- 2 On Model 247624, rotate manifold 180 degrees about the vertical axis.

43. Hold one spacer with the 1/2 in. open-end wrench and the other with the 1/2 in. torque wrench and torque to 15 ft-lb (20 N•m).

**NOTE:** This ensures that the manifold is aligned with the pump assembly.

44. Repeat with the final two spacers.

# Parts

## Pumpline

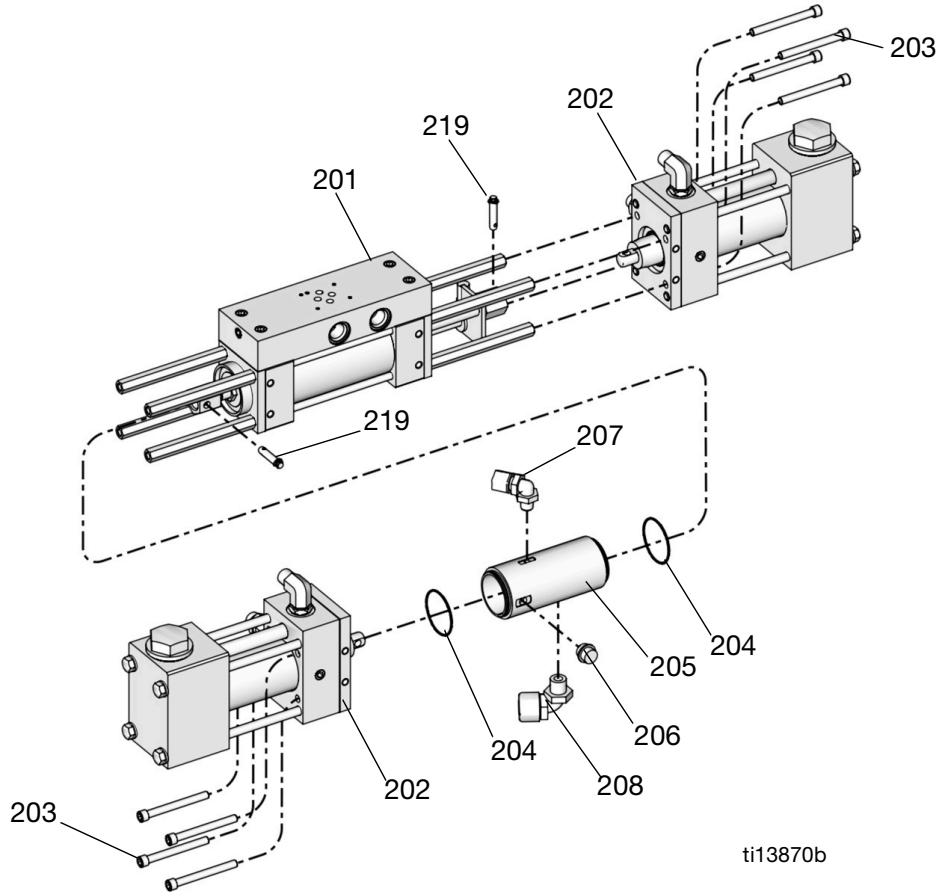

ti13870b

Ref.	Description	Pumpline Assembly			Qty.
		288638	288639	P7758-255773	
201	CYLINDER, hydraulic	295027	295027	247624	1
202	PUMP, proportioner	247375	247377	247375	2
203	SCREW, cap, socket head	295824	295824	0204-5	8
204	PACKING, o-ring	106258	106258	106258	2
205	CYLINDER, lube	261863	261863	261863	1
206	FITTING, plug	295829	295829	295829	1
207	FITTING, elbow, 90 degree	295826	295826	295826	1
208	FITTING, elbow, 90 degree	295397	295397	295397	1
219	PIN, clevis	296653	296653	296653	2

Lined writing area with horizontal lines.

# Piston and Cylinder Seals

A Side Shown

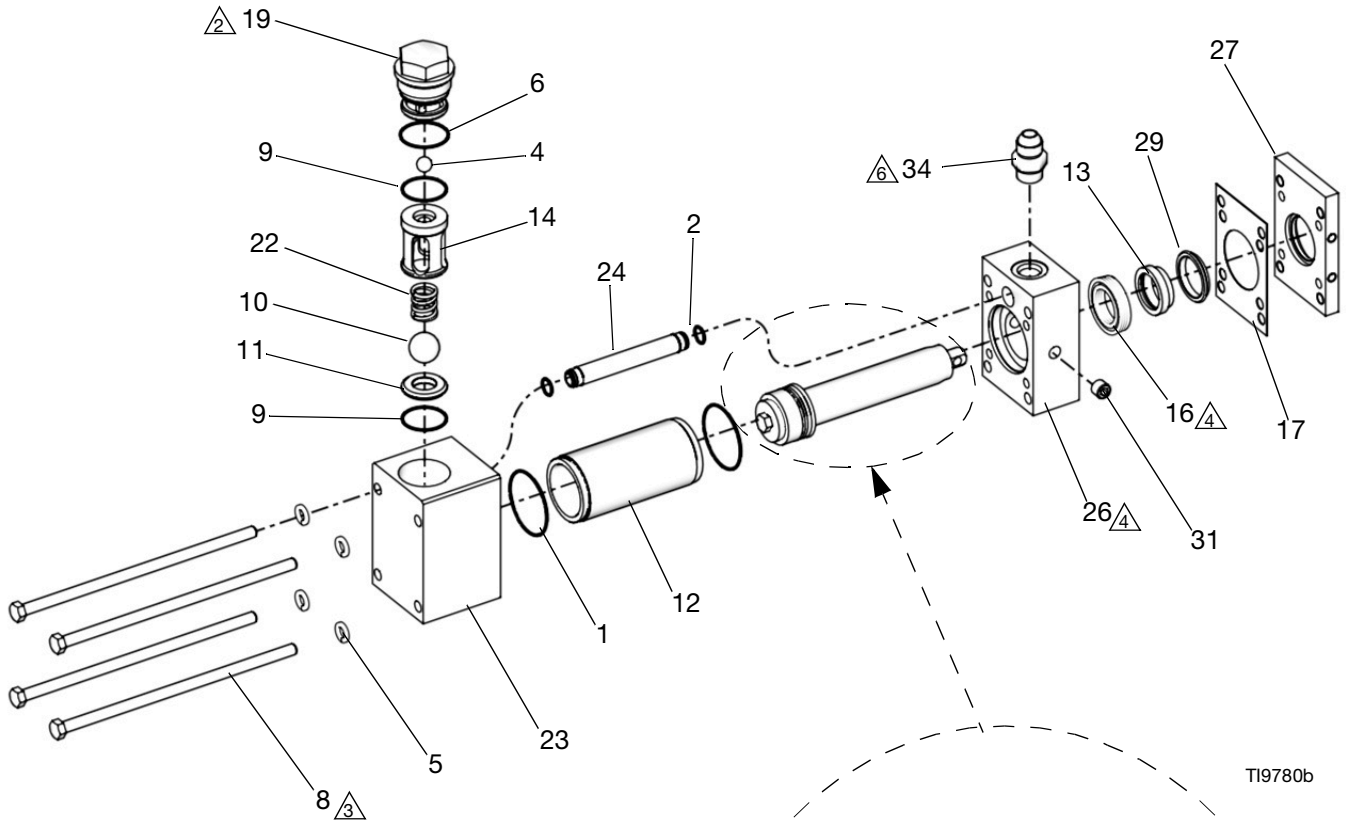

**NOTE:** B side of pump is same as A side except items 31 and 34 are reversed.

- △1 Apply supplied sealant to threads
- △2 Torque to 75 ft-lb (101.3 N•m)
- △3 Torque to 45 ft-lb (60.8 N•m)
- △4 Seal must be pressed straight into housing
- △5 See Torque Specification table for torque according to pump size
- △6 Part not used on Model P7758-255773

### Item 25 Torque Specification

Pump Size	Torque
30	130 in-lb (14.7 N•m)
28, 40, 48, 60	22 ft-lb (29.7 N•m)
80, 88, 96, 120, 140	45 ft-lb (60.8 N•m)

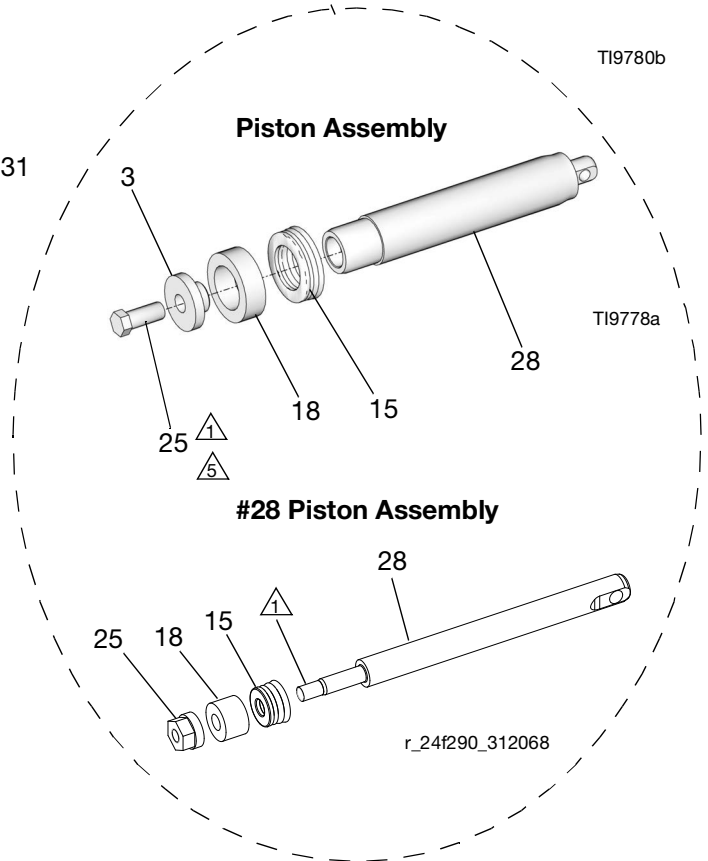

Ref.	Part	Description	Qty.			
				18*		BUSHING, piston, acetal 1
1‡		O-RING, PTFE	2	19	261867	CAP, ball guide 1
2‡		O-RING, TPE	2	22	261897	SPRING, valve 1
3◆		CAP, piston	1	23	261903	PUMP, base 1
4‡	105445	BALL, valve, outlet, SST; 1/2 in. (13 mm) diameter	1	24	261898	TUBE, crossover 1
5	261866	WASHER, flat, packing support (4 pack)	1	25*		SCREW, hex hd cap 1
6‡		O-RING, PTFE	1	26◆		FLANGE, outlet 1
8	261865	SCREW, hex hd cap; 3/8-24 x 9.0 in. (228 mm) (4 pack)	1	27	261875	RETAINER, flange 1
9‡		O-RING, PTFE	2	28◆		ROD, piston; includes cap (ref. 3) 1
10‡	107167	BALL, valve, inlet, SST; 1 in. (25 mm) diameter	1	29◆		ADAPTER, throat 1
11	193395	SEAT, ball, inlet, carbide	1	31	295225	PLUG, pipe, flush 1
12◆		CYLINDER	1	34	121312	ELBOW, 3/4-16 unf x 1/2 in. (13 mm) O.D. tube (not used on Model P7758-255773) 1
13+		BUSHING, throat, acetal	1			
14	261899	GUIDE, inlet ball, with outlet ball seat	1			
15*		SEAL, piston, u-cup	1			
16+		SEAL, throat, u-cup	1			
17+		GASKET	1			

◆ Refer to Table 1 for part number.  
 + Refer to Table 2 for part number.  
 \* Refer to Table 3 for part number.  
 ‡ Parts included in Kit 261859 (purchase separately).

**Table 1. Proportioning Pump Parts**

Ref.	Pump Sizes and Part Numbers									
	#28	#30	#40	#48	#60	#80	#88	#96	#120	#140
	<b>24F291</b>	<b>247371</b>	<b>247372</b>	<b>247373</b>	<b>247374</b>	<b>247375</b>	<b>247577</b>	<b>247376</b>	<b>247377</b>	<b>247576</b>
<b>3</b>	16F204	261889	261886	261886	261886	261883	261883	261883	261883	261883
<b>12</b>	24F294	261896	261895	261894	261893	261892	247582	261891	261890	247583
<b>26</b>	261902	261902	261902	261902	261902	261901	261901	261901	261901	261901
<b>28</b>	16F202	261882	261881	261880	261879	261878	247584	261877	261876	247585
<b>29</b>	261874	261874	261873	261872	261871	261870	247586	261869	261868	247587

**Table 2. Cylinder Seal Kits; Includes Parts 13, 16, 17**

Pump	Proportioning Pump Size	Kit
24F291	28	261858
247371	30	261858
247372	40	261857
247373	48	261856
247374	60	261855
247375	80	261854
247577	88	247580
247376	96	261853
247377	120	261852
247576	140	247581

**Table 3. Piston Seal Kits; Includes Parts 15, 18, 25**

Pump	Proportioning Pump Size	Kit
24F291	28	24F292
247371	30	261851
247372	40	261850
247373	48	261849
247374	60	261848
247375	80	261847
247577	88	247578
247376	96	261846
247377	120	261845
247576	140	247579

# Hydraulic Cylinder

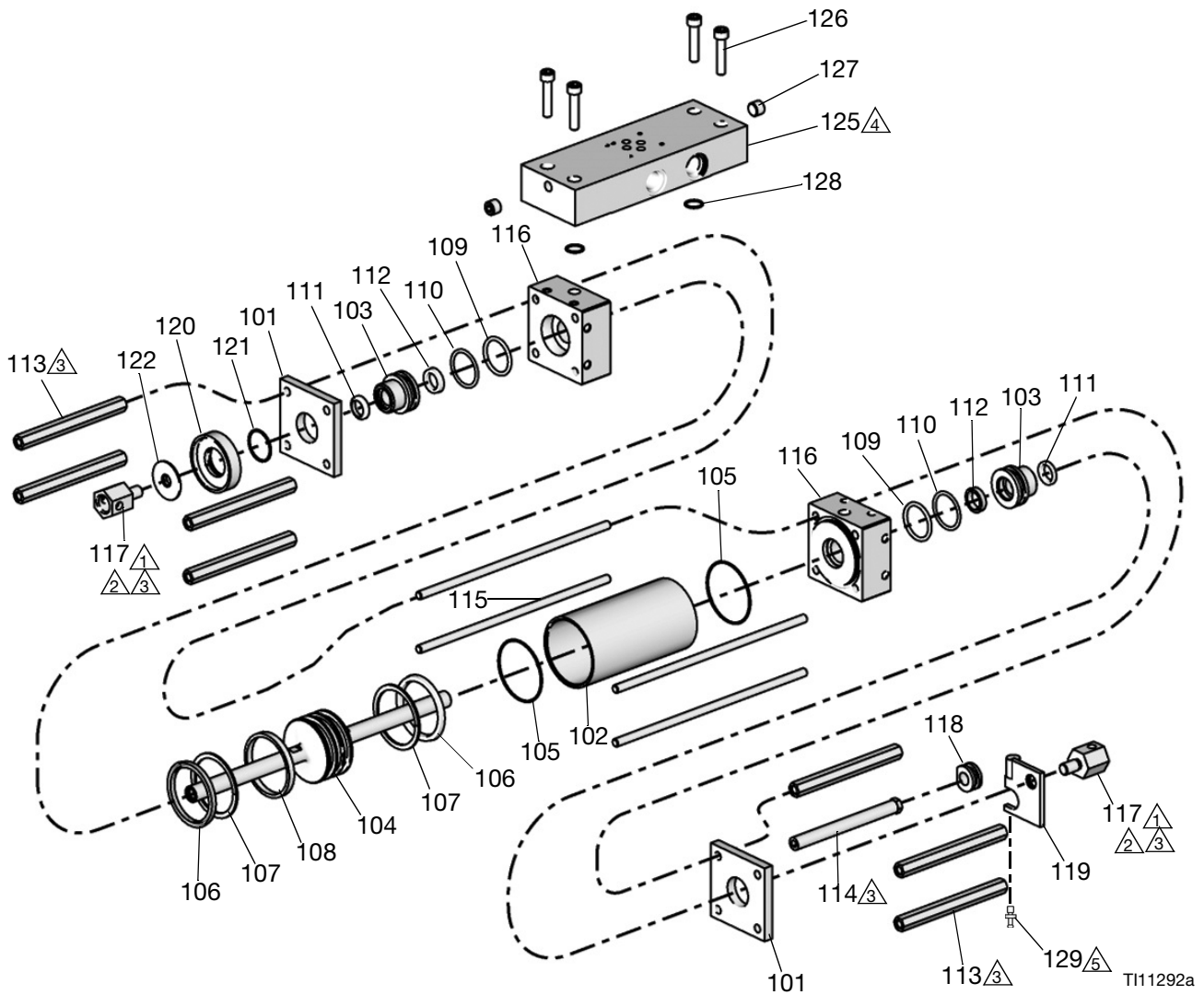

- ① Apply high strength thread sealant to threads.
- ② Apply primer to threads to speed curing.
- ③ Torque to 40+/-5 ft-lb (54+/-6 N•m). See assembly section for correct procedure.
- ④ On Model 247624, rotate manifold 180 degrees about the vertical axis.
- ⑤ Part used only on Model P7758-255773.

TI11292a

Ref.	Part	Description	Qty.	Ref.	Part	Description	Qty.
101	295029	PLATE, retainer	2	121	177156	O-RING	1
102	295030	CYLINDER	1	122	295852	NUT, jam, baffle	1
103◆	295031	BUSHING, rod	2	123		SOLVENT, catalyst, liquid	1
104	296642	PISTON, hydraulic	1	124		SEALANT, anaerobic	1
105◆	295640	O-RING	2	125	298040	MANIFOLD, hydraulic	1
106◆	295641	SEAL, u-cup	2			(used only on Model 247624)	
107◆	295642	RING, back-up	2	126	113467	SCREW, cap, socket head	4
108◆	296643	RING, wear	1			(used only on Model 247624)	
109◆	158776	PACKING, o-ring	2	127	295225	PLUG, pipe, flush	2
110◆	295644	RING, back-up	2			(used only on Model 247624)	
111◆	295645	WIPER, rod	2	128	112793	O-RING	2
112◆	296644	SEAL, shaft	2			(used only on Model 247624)	
113	295032	SPACER, proportioner pump	7	129	OP307-2	PIN, link	1
114	261502	SPACER, reverse switch pump	1		-1000	(used only on Model P7758-255773)	
115	295034	ROD, tie	4	130	296653	PIN, clevis; not shown	2
116	295035	BLOCK, port	2			(used only on Model 255723)	
117	261864	CLEVIS, hex, proportioner	2				
118	261862	BUSHING, modified	1				
		(used on Models 247624, 255723., 295027)	1				
	1501-7-2	BUSHING					
		(used on Model P7758-255773)					
119	261507	PLATE, activator	1				
		(used on Model 295027)					
	42430-4	PLATE, activator	1				
		(used on Model P7758-255773)					
	247607	PLATE, activator	1				
		(used on Model 255723)					
120	261863	ADAPTER, lube, cylinder	1				

◆ *Parts are also included in Hydraulic Cylinder Repair Kit 296785 which can be purchased separately.*





## Technical Specifications

Category	Data
Maximum working pressure	<i>Model 247576:</i> 2000 psi (13.8 MPa, 138 bar) <i>All other models:</i> 3500 psi (24.0 MPa, 240 bar)
Maximum fluid temperature	120°F (49°C)
Viscosity range	250-1500 centipoise
Maximum material inlet pressure	400 psi (2.7 MPa, 27 bar)
Wetted parts	Carbon Steel, Stainless Steel, Chrome, PTFE, Acetal, UHMWPE

## California Proposition 65

### CALIFORNIA RESIDENTS

 **WARNING:** Cancer and reproductive harm – [www.P65warnings.ca.gov](http://www.P65warnings.ca.gov).

# Graco Standard Warranty

Graco warrants all equipment referenced in this document which is manufactured by Graco and bearing its name to be free from defects in material and workmanship on the date of sale to the original purchaser for use. With the exception of any special, extended, or limited warranty published by Graco, Graco will, for a period of twelve months from the date of sale, repair or replace any part of the equipment determined by Graco to be defective. This warranty applies only when the equipment is installed, operated and maintained in accordance with Graco's written recommendations.

This warranty does not cover, and Graco shall not be liable for general wear and tear, or any malfunction, damage or wear caused by faulty installation, misapplication, abrasion, corrosion, inadequate or improper maintenance, negligence, accident, tampering, or substitution of non-Graco component parts. Nor shall Graco be liable for malfunction, damage or wear caused by the incompatibility of Graco equipment with structures, accessories, equipment or materials not supplied by Graco, or the improper design, manufacture, installation, operation or maintenance of structures, accessories, equipment or materials not supplied by Graco.

This warranty is conditioned upon the prepaid return of the equipment claimed to be defective to an authorized Graco distributor for verification of the claimed defect. If the claimed defect is verified, Graco will repair or replace free of charge any defective parts. The equipment will be returned to the original purchaser transportation prepaid. If inspection of the equipment does not disclose any defect in material or workmanship, repairs will be made at a reasonable charge, which charges may include the costs of parts, labor, and transportation.

**THIS WARRANTY IS EXCLUSIVE, AND IS IN LIEU OF ANY OTHER WARRANTIES, EXPRESS OR IMPLIED, INCLUDING BUT NOT LIMITED TO WARRANTY OF MERCHANTABILITY OR WARRANTY OF FITNESS FOR A PARTICULAR PURPOSE.**

Graco's sole obligation and buyer's sole remedy for any breach of warranty shall be as set forth above. The buyer agrees that no other remedy (including, but not limited to, incidental or consequential damages for lost profits, lost sales, injury to person or property, or any other incidental or consequential loss) shall be available. Any action for breach of warranty must be brought within two (2) years of the date of sale.

**GRACO MAKES NO WARRANTY, AND DISCLAIMS ALL IMPLIED WARRANTIES OF MERCHANTABILITY AND FITNESS FOR A PARTICULAR PURPOSE, IN CONNECTION WITH ACCESSORIES, EQUIPMENT, MATERIALS OR COMPONENTS SOLD BUT NOT MANUFACTURED BY GRACO.** These items sold, but not manufactured by Graco (such as electric motors, switches, hose, etc.), are subject to the warranty, if any, of their manufacturer. Graco will provide purchaser with reasonable assistance in making any claim for breach of these warranties.

In no event will Graco be liable for indirect, incidental, special or consequential damages resulting from Graco supplying equipment hereunder, or the furnishing, performance, or use of any products or other goods sold hereto, whether due to a breach of contract, breach of warranty, the negligence of Graco, or otherwise.

## **FOR GRACO CANADA CUSTOMERS**

The Parties acknowledge that they have required that the present document, as well as all documents, notices and legal proceedings entered into, given or instituted pursuant hereto or relating directly or indirectly hereto, be drawn up in English. Les parties reconnaissent avoir convenu que la rédaction du présente document sera en Anglais, ainsi que tous documents, avis et procédures judiciaires exécutés, donnés ou intentés, à la suite de ou en rapport, directement ou indirectement, avec les procédures concernées.

# Graco Information

For the latest information about Graco products, visit [www.graco.com](http://www.graco.com).

For patent information, see [www.graco.com/patents](http://www.graco.com/patents).

**TO PLACE AN ORDER, contact your Graco distributor or call to identify the nearest distributor.**

**Phone: 612-623-6921 or Toll Free: 1-800-328-0211 Fax: 612-378-3505**

*All written and visual data contained in this document reflects the latest product information available at the time of publication. Graco reserves the right to make changes at any time without notice.*

Original instructions. This manual contains English. MM 312068

**Graco Headquarters:** Minneapolis

**International Offices:** Belgium, China, Japan, Korea

**GRACO INC. AND SUBSIDIARIES • P.O. BOX 1441 • MINNEAPOLIS MN 55440-1441 • USA**  
**Copyright 2021, Graco Inc. All Graco manufacturing locations are registered to ISO 9001.**

[www.graco.com](http://www.graco.com)

Revision U, December 2021