

Dura-Flo™ Pumps

311826M
EN

Carbon Steel or Stainless Steel Pumps, with Severe-Duty or MaxLife® Rod and Cylinder.
For professional use only.

Dura-Flo 1800 (430 cc) Pump
Dura-Flo 2400 (580 cc) Pump



Important Safety Instructions

Read all warnings and instructions in this manual.
Save these instructions.

See page 3 for model information, including maximum working pressure.

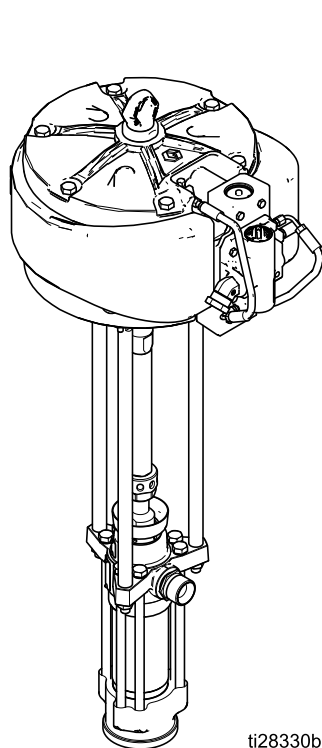

ti28330b

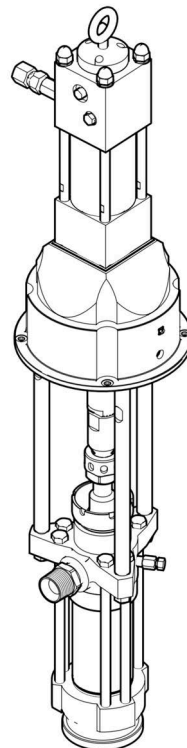

ti8885c

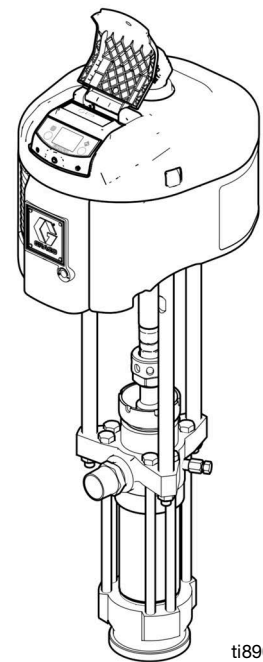

ti8900b



Contents

Models	3
Dura-Flo Pumps with NXT™ Air Motors	3
Dura-Flo Pumps with Viscount® Hydraulic Motors	6
Dura-Flo Pumps with Xtreme® XL Air Motors ...	6
Warnings	7
Installation	9
Grounding	9
Flush Before Using Equipment	9
Mounting Accessories	9
Hoses	9
Air Line Accessories	10
Hydraulic Line Accessories	10
Fluid Line Accessories	10
Operation	13
Pressure Relief Procedure	13
Trigger Lock	13
Startup	13
Shutdown	14

Maintenance	15
Preventive Maintenance Schedule	15
Wet-Cups	15
Flushing	15
Corrosion Protection	15
Hydraulic Systems	15
Troubleshooting	16
Repair	17
Required Tools	17
Disconnect the Lower	17
Reconnect the Lower	18
Parts	20
Dura-Flo Pumps with NXT Air Motors	20
Dura-Flo Pumps with Viscount Hydraulic Motors	23
Dura-Flo Pumps with Xtreme XL Air Motors ...	24
Dimensions	25
Mounting Hole Layouts	26
Technical Data	28
Graco Standard Warranty	34
Graco Information	34

Models

Dura-Flo Pumps with NXT™ Air Motors

Check your pump's identification plate (ID) for the 6-digit part number of your pump. Use the following matrix to define the construction of your pump, based on the six digits. For example, Pump Part No. **P 1 5 M C D** represents the pump (**P**), pressure ratio (**1 5** :1), low noise exhaust motor with DataTrak™ (**M**), carbon steel construction (**C**), and 3 ptfе/2 leather packing configuration (**D**). To order replacement parts, see **Parts** section starting on page 20. The digits in the matrix do not correspond to the Ref. Nos. in the Parts drawings and lists.

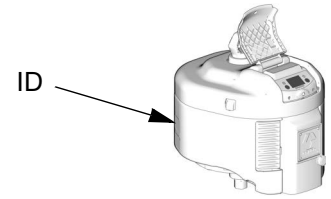

P	1 5	M			C	D		
First Digit	Second and Third Digit	Fourth Digit			Fifth Digit		Sixth Digit	
		Pressure Ratio (xx:1)	Exhaust	Communication		Material		Packings
P (pumps)	12	D	De-Icing	none	C	Carbon Steel	A	3 uhmwpe/2 ptfе
	15	E	De-Icing	DataTrak	S	Stainless Steel	B	3 uhmwpe/2 Tuff-Stack™
	23	L	Low Noise	none			D	3 ptfе/2 leather
	32	M	Low Noise	DataTrak			S	Severe Duty
			H	Low Noise	High Level Sensor			M

Pump Part No. and Series	Lower Part No.	Lower Model, Packings	Air Motor Part No.	Ratio	Maximum Working Pressure MPa, bar (psi)	Maximum Air Input Pressure MPa, bar (psi)
P12LCD, A	222801	Dura-Flo 2400 (580 cc) cst, 3 PTFE/2 leather	N34LN0	12:1	8.2, 82 (1190)	0.7, 7.0 (100)
P12LSA, A	222803	Dura-Flo 2400 (580 cc) sst, 3 UHMWPE/2 PTFE	N34LN0	12:1	8.2, 82 (1190)	0.7, 7.0 (100)
P12MCD, A	222801	Dura-Flo 2400 (580 cc) cst, 3 PTFE/2 leather	N34LT0	12:1	8.2, 82 (1190)	0.7, 7.0 (100)
P12MSA, A	222803	Dura-Flo 2400 (580 cc) sst, 3 UHMWPE/2 PTFE	N34LT0	12:1	8.2, 82 (1190)	0.7, 7.0 (100)
P12DSA, A	222803	Dura-Flo 2400 (580 cc) sst, 3 UHMWPE/2 PTFE	N34DN0	12:1	8.2, 82 (1190)	0.7, 7.0 (100)
P12ESA, A	222803	Dura-Flo 2400 (580 cc) sst, 3 UHMWPE/2 PTFE	N34DT0	12:1	8.2, 82 (1190)	0.7, 7.0 (100)
P12HSM, A	L580SM	Dura-Flo 2400 (580 cc) sst, 4 leather/3 UHMWPE	N34LH0	12:1	8.2, 82 (1190)	0.7, 7.0 (100)
P12DCD, A	222801	Dura-Flo 2400 (580 cc) cst, 3 PTFE/2 leather	N34DN0	12:1	8.2, 82 (1190)	0.7, 7.0 (100)
P12HSS, A	L580SS	Dura-Flo 2400 (580 cc) sst, 3 UHMWPE/2 PTFE	N34LH0	12:1	8.2, 82 (1190)	0.7, 7.0 (100)

Continued on page 4.

Models

Pump Part No. and Series	Lower Part No.	Lower Model, Packings	Air Motor Part No.	Ratio	Maximum Working Pressure MPa, bar (psi)	Maximum Air Input Pressure MPa, bar (psi)
P12ECD, A	222801	Dura-Flo 2400 (580 cc) cst, 3 PTFE/2 leather	N34DT0	12:1	8.2, 82 (1190)	0.7, 7.0 (100)
P12LSM, A	L580SM	Dura-Flo 2400 (580 cc) sst, 4 leather/3 UHMWPE	N34LN0	12:1	8.2, 82 (1190)	0.7, 7.0 (100)
P12LSS, A	L580SS	Dura-Flo 2400 (580 cc) sst, 2 PTFE/3 UHMWPE	N34LN0	12:1	8.2, 82 (1190)	0.7, 7.0 (100)
P12HSM, A	L580SM	Dura-Flo 2400 (580 cc) sst, 4 leather/3 UHMWPE	N34LH0	12:1	8.2, 82 (1190)	0.7, 7.0 (100)
P12HSS, A	L580SS	Dura-Flo 2400 (580 cc) sst, 2 PTFE/3 UHMWPE	N34LH0	12:1	8.2, 82 (1190)	0.7, 7.0 (100)
P15LCD, A	222796	Dura-Flo 1800 (430 cc) cst, 3 PTFE/2 leather	N34LN0	15:1	10.9, 109 (1580)	0.7, 7.0 (100)
P15LSB, A	687055	Dura-Flo 1800 (430 cc) sst, 3 UHMWPE/2 PTFE	N34LN0	15:1	10.9, 109 (1580)	0.7, 7.0 (100)
P15MCD, A	222796	Dura-Flo 1800 (430 cc) cst, 3 PTFE/2 leather	N34LT0	15:1	10.9, 109 (1580)	0.7, 7.0 (100)
P15MSB, A	687055	Dura-Flo 1800 (430 cc) cst, 3 PTFE/2 leather	N34LT0	15:1	10.9, 109 (1580)	0.7, 7.0 (100)
P15DSB, A	687055	Dura-Flo 1800 (430 cc) sst, 3 UHMWPE/2 PTFE	N34DT0	15:1	10.9, 109 (1580)	0.7, 7.0 (100)
P15ESB, A	687055	Dura-Flo 1800 (430 cc) sst, 3 UHMWPE/2 PTFE	N34DN0	15:1	10.9, 109 (1580)	0.7, 7.0 (100)
P15HSM, A	L430SM	Dura-Flo 1800 (430 cc) sst, 4 leather/3 UHMWPE	N34LH0	15:1	10.9, 109 (1580)	0.7, 7.0 (100)
P15DCD, A	222796	Dura-Flo 1800 (430 cc) cst, 3 PTFE/2 leather	N34DN0	15:1	10.9, 109 (1580)	0.7, 7.0 (100)
P15HSS, A	L430SS	Dura-Flo 1800 (430 cc) sst, 2 PTFE/3 UHMWPE	N34LH0	15:1	10.9, 109 (1580)	0.7, 7.0 (100)
P15ECD, A	222796	Dura-Flo 1800 (430 cc) cst, 3 PTFE/2 leather	N34DT0	15:1	10.9, 109 (1580)	0.7, 7.0 (100)
P15LSM, A	L430SM	Dura-Flo 1800 (430 cc) sst, 4 leather/3 UHMWPE	N34DT0	15:1	10.9, 109 (1580)	0.7, 7.0 (100)
P15LSS, A	L430SS	Dura-Flo 1800 (430 cc) sst, 2 PTFE/3 UHMWPE	N34DT0	15:1	10.9, 109 (1580)	0.7, 7.0 (100)
P22HSM, A	L580SM	Dura-Flo 2400 (580 cc) sst, 4 leather/3 UHMWPE	N65LH0	22:1	15.7, 157 (2270)	0.7, 7.0 (100)
P22HSS, A	L580SS	Dura-Flo 2400 (580 cc) sst, 2 PTFE/3 UHMWPE	N65LH0	22:1	15.7, 157 (2270)	0.7, 7.0 (100)
P22LCS	L580CS	Dura-Flo 2400 (580 cc) cst, 2 PTFE/3 UHMWPE	N65LN0	22:1	15.7, 157 (2270)	0.7, 7.0 (100)
P22LSM	L580SM	Dura-Flo 2400 (580 cc) sst, 4 leather/3 UHMWPE	N65LN0	22:1	15.7, 157 (2270)	0.7, 7.0 (100)
P22LSS	L580SS	Dura-Flo 2400 (580 cc) sst, 2 PTFE/3 UHMWPE	N65LN0	22:1	15.7, 157 (2270)	0.7, 7.0 (100)
P23DCD, A	222801	Dura-Flo 2400 (580 cc) cst, 3 PTFE/2 leather	N65DN0	23:1	15.7, 157 (2270)	0.7, 7.0 (100)
P23ECD, A	222801	Dura-Flo 2400 (580 cc) cst, 3 PTFE/2 leather	N65DT0	23:1	15.7, 157 (2270)	0.7, 7.0 (100)

Pump Part No. and Series	Lower Part No.	Lower Model, Packings	Air Motor Part No.	Ratio	Maximum Working Pressure MPa, bar (psi)	Maximum Air Input Pressure MPa, bar (psi)
P23LCD, A	222801	Dura-Flo 2400 (580 cc) cst, 3 PTFE/2 leather	N65LN0	23:1	15.7, 157 (2270)	0.7, 7.0 (100)
P23LSA, A	222803	Dura-Flo 2400 (580 cc) sst, 3 UHMWPE/2 PTFE	N65LN0	23:1	15.7, 157 (2270)	0.7, 7.0 (100)
P23MCD, A	222801	Dura-Flo 2400 (580 cc) cst, 3 PTFE/2 leather	N65LT0	23:1	15.7, 157 (2270)	0.7, 7.0 (100)
P23MSA, A	222803	Dura-Flo 2400 (580 cc) sst, 3 UHMWPE/2 PTFE	N65LT0	23:1	15.7, 157 (2270)	0.7, 7.0 (100)
P23DSA, A	222803	Dura-Flo 2400 (580 cc) sst, 3 UHMWPE/2 PTFE	N65DN0	23:1	15.7, 157 (2270)	0.7, 7.0 (100)
P23ESA, A	222803	Dura-Flo 2400 (580 cc) sst, 3 UHMWPE/2 PTFE	N65DT0	23:1	15.7, 157 (2270)	0.7, 7.0 (100)
P32DCD, A	222796	Dura-Flo 1800 (430 cc) cst, 3 PTFE/2 leather	N65DN0	32:1	20.9, 209 (3030)	0.7, 7.0 (100)
P32ECD, A	222796	Dura-Flo 1800 (430 cc) cst, 3 PTFE/2 leather	N65DT0	32:1	20.9, 209 (3030)	0.7, 7.0 (100)
P32HSM	L430SM	Dura-Flo 1800 (430 cc) sst, 4 leather/3 UHMWPE	N65LH0	32:1	20.9, 209 (3030)	0.7, 7.0 (100)
P32LCD, A	222796	Dura-Flo 1800 (430 cc) cst, 3 PTFE/2 leather	N65LN0	32:1	20.9, 209 (3030)	0.7, 7.0 (100)
P32HSS	L430SS	Dura-Flo 1800 (430 cc) sst, 3 UHMWPE/ 2 PTFE	N65LH0	32:1	20.9, 209 (3030)	0.7, 7.0 (100)
P32LSB, A	687055	Dura-Flo 1800 (430 cc) sst, 3 UHMWPE/2 PTFE	N65LN0	32:1	20.9, 209 (3030)	0.7, 7.0 (100)
P32LSM	L430SM	Dura-Flo 1800 (430 cc) sst, 4 leather/3 UHMWPE	N65LN0	32:1	20.9, 209 (3030)	0.7, 7.0 (100)
P32DSB, A	687055	Dura-Flo 1800 (430 cc) sst, 3 UHMWPE/2 PTFE	N65DN0	32:1	20.9, 209 (3030)	0.7, 7.0 (100)
P32LSS	L430SS	Dura-Flo 1800 (430 cc) sst, 3 UHMWPE/2 PTFE	N65LN0	32:1	20.9, 209 (3030)	0.7, 7.0 (100)
P32ESB, A	687055	Dura-Flo 1800 (430 cc) sst, 3 UHMWPE/2 PTFE	N65DT0	32:1	20.9, 209 (3030)	0.7, 7.0 (100)
P32MCD, A	222796	Dura-Flo 1800 (430 cc) cst, 3 PTFE/2 leather	N65LT0	32:1	20.9, 209 (3030)	0.7, 7.0 (100)
P32MSB, A	687055	Dura-Flo 1800 (430 cc) sst, 3 UHMWPE/2 PTFE	N65LT0	32:1	20.9, 209 (3030)	0.7, 7.0 (100)

Dura-Flo Pumps with Viscount® Hydraulic Motors

Check your pump's identification plate (ID) for the 6-digit part number of your pump. To order replacement parts, see **Parts** section starting on page 20.

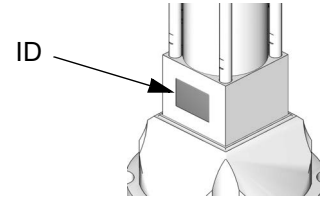

Pump Part No. and Series	Lower Part No.	Lower Model, Packings	Hydraulic Motor Part No.	Maximum Working Pressure MPa, bar (psi)	Maximum Hydraulic Input Pressure MPa, bar (psi)
222892, B	222796	Dura-Flo 1800 (430 cc) cst, 3 PTFE/2 leather	235345	18.0, 179 (2600)	10, 103 (1500)
222897, B	222805	Dura-Flo 1800 (430 cc) sst, 3 UHMWPE/2 PTFE	235345	18.0, 179 (2600)	10, 103 (1500)
222834, B	222801	Dura-Flo 2400 (580 cc) cst, 3 PTFE/2 leather	235345	14.0, 138 (2000)	10, 103 (1500)
222900, B	222803	Dura-Flo 2400 (580 cc) sst, 3 UHMWPE/2 PTFE	235345	14.0, 138 (2000)	10, 103 (1500)





Dura-Flo Pumps with Xtreme® XL Air Motors

To order replacement parts, see **Parts** section starting on page 20.



Pump Part No. and Series	Lower Part No.	Lower Model, Packings	Air Motor Part No.	Maximum Working Pressure MPa, bar (psi)	Maximum Air Input Pressure MPa, bar (psi)
P35LSS	L580SS	Dura-Flo 2400 (580 cc) sst, 2 PTFE/3 UHMWP	24X856	24.1, 241 (3500)	0.7, 7.0 (100)
P47LSS	L430SS	Dura-Flo 1800 (430 cc) sst, 2 PTFE/3 UHMWP	24X856	32.4, 324 (4700)	0.7, 7.0 (100)
P35LCS	L580CS	Dura-Flo 2400 (580 cc) carbon steel, 2 PTFE/3 UHMWP	24X856	24.1, 241 (3500)	0.7, 7.0 (100)
P35LSM	L580SM	Dura-Flo 2400 (580 cc) sst, 2 leather/3 UHMWP	24X856	24.1, 241 (3500)	0.7, 7.0 (100)
P47LCS	L430CS	Dura-Flo 1800 (430 cc) carbon steel, 2 PTFE/3 UHMWP	24X856	32.4, 324 (4700)	0.7, 7.0 (100)
P47LCM	L430CM	Dura-Flo 1800 (430 cc) sst, 2 leather/3 UHMWP	24X856	32.4, 324 (4700)	0.7, 7.0 (100)
P47LSM	L430SM	Dura-Flo 1800 (430 cc) sst, 2 leather/3 UHMWP	24X856	32.4, 324 (4700)	0.7, 7.0 (100)

Warnings

The following warnings are for the setup, use, grounding, maintenance, and repair of this equipment. The exclamation point symbol alerts you to a general warning and the hazard symbol refers to procedure-specific risk. Refer back to these warnings. Additional, product-specific warnings may be found throughout the body of this manual where applicable.

 WARNING	
	<p>FIRE AND EXPLOSION HAZARD</p> <p>Flammable fumes, such as solvent and paint fumes, in work area can ignite or explode. To help prevent fire and explosion:</p> <ul style="list-style-type: none"> • Use equipment only in well ventilated area. • Eliminate all ignition sources; such as pilot lights, cigarettes, portable electric lamps, and plastic drop cloths (potential static arc). • Keep work area free of debris, including solvent, rags and gasoline. • Do not plug or unplug power cords, or turn power or light switches on or off when flammable fumes are present. • Ground all equipment in the work area. See Grounding instructions. • Use only grounded hoses. • Hold gun firmly to side of grounded pail when triggering into pail. • If there is static sparking or you feel a shock, stop operation immediately. Do not use equipment until you identify and correct the problem. • Keep a working fire extinguisher in the work area.
	<p>SKIN INJECTION HAZARD</p> <p>High-pressure fluid from gun, hose leaks, or ruptured components will pierce skin. This may look like just a cut, but it is a serious injury that can result in amputation. Get immediate surgical treatment.</p> <ul style="list-style-type: none"> • Do not point gun at anyone or at any part of the body. • Do not put your hand over the spray tip. • Do not stop or deflect leaks with your hand, body, glove, or rag. • Do not spray without tip guard and trigger guard installed. • Engage trigger lock when not spraying. • Follow Pressure Relief Procedure in this manual, when you stop spraying and before cleaning, checking, or servicing equipment.
	<p>EQUIPMENT MISUSE HAZARD</p> <p>Misuse can cause death or serious injury.</p> <ul style="list-style-type: none"> • Do not operate the unit when fatigued or under the influence of drugs or alcohol. • Do not exceed the maximum working pressure or temperature rating of the lowest rated system component. See Technical Data in all equipment manuals. • Use fluids and solvents that are compatible with equipment wetted parts. See Technical Data in all equipment manuals. Read fluid and solvent manufacturer's warnings. For complete information about your material, request MSDS forms from distributor or retailer. • Check equipment daily. Repair or replace worn or damaged parts immediately with genuine manufacturer's replacement parts only. • Do not alter or modify equipment. • Use equipment only for its intended purpose. Call your distributor for information. • Route hoses and cables away from traffic areas, sharp edges, moving parts, and hot surfaces. • Do not kink or over bend hoses or use hoses to pull equipment. • Keep children and animals away from work area. • Comply with all applicable safety regulations.

WARNING

	<p>MOVING PARTS HAZARD</p> <p>Moving parts can pinch or amputate fingers and other body parts.</p> <ul style="list-style-type: none"> • Keep clear of moving parts. • Do not operate equipment with protective guards or covers removed. • Pressurized equipment can start without warning. Before checking, moving, or servicing equipment, follow the Pressure Relief Procedure in this manual. Disconnect power or air supply.
	<p>TOXIC FLUID OR FUMES HAZARD</p> <p>Toxic fluids or fumes can cause serious injury or death if splashed in the eyes or on skin, inhaled, or swallowed.</p> <ul style="list-style-type: none"> • Read MSDS's to know the specific hazards of the fluids you are using. • Store hazardous fluid in approved containers, and dispose of it according to applicable guidelines. • Always wear impervious gloves when spraying or cleaning equipment.
	<p>PERSONAL PROTECTIVE EQUIPMENT</p> <p>You must wear appropriate protective equipment when operating, servicing, or when in the operating area of the equipment to help protect you from serious injury, including eye injury, inhalation of toxic fumes, burns, and hearing loss. This equipment includes but is not limited to:</p> <ul style="list-style-type: none"> • Protective eyewear • Clothing and respirator as recommended by the fluid and solvent manufacturer • Gloves • Hearing protection

Installation

Grounding

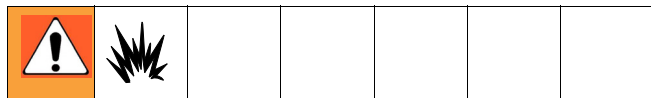

The equipment must be grounded. Grounding reduces the risk of static and electric shock by providing an escape wire for the electrical current due to static build up or in the event of a short circuit.

Pump: Use the ground screw (GS) and lockwasher on the motor to attach a 244524 ground wire (Y). Tighten the screw securely. Connect the other end of the ground wire to a true earth ground.

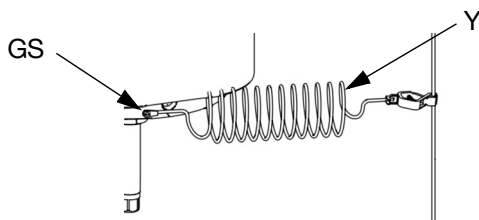

T18250b

Air and fluid hoses: use only electrically conductive hoses.

Air compressor or hydraulic power supply: follow manufacturer's recommendations.

Spray gun: ground through connection to a properly grounded fluid hose and pump.

Fluid supply container: follow local code.

Object being sprayed: follow local code.

Solvent pails used when flushing: follow local code. Use only conductive metal pails, placed on a grounded surface. Do not place the pail on a nonconductive surface, such as paper or cardboard, which interrupts grounding continuity.

To maintain grounding continuity when flushing or relieving pressure: hold metal part of the spray gun firmly to the side of a grounded metal pail, then trigger the gun.

Flush Before Using Equipment

The equipment was tested with lightweight oil, which is left in the fluid passages to protect parts. To avoid contaminating your fluid with oil, flush the equipment with a compatible solvent before using the equipment. See **Flushing**, page 15.

Mounting Accessories

See **Dimensions**, page 25 and **Mounting Hole Layouts**, page 26.

FIG. 1 shows an air-powered system and FIG. 2 shows a hydraulic-powered system.

Hoses

See FIG. 1 and FIG. 2. Be sure all hoses are properly sized and pressure-rated for your system. Use only electrically conductive hoses. Fluid hoses must have spring guards on both ends. Use a whip hose (P) and a swivel (R) between the main fluid hose (N) and the gun/valve (S) to allow freer gun/valve movement.

Air Line Accessories

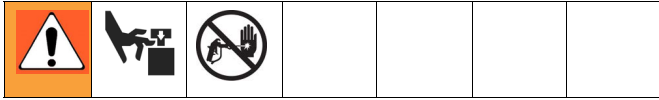

For air-powered pumps, install the following accessories in the order shown in FIG. 1, using adapters as necessary.

 Accessory Air Control Kits are available for the NXT Air Motor. The kits include a master air valve (E), air regulator (F), and filter (J). Order the kit separately. See manual 311239 for information.

- **Bleed-type master air valve (E):** required in your system to relieve air trapped between it and the air motor when the valve is closed. Be sure the valve is easily accessible from the pump and located downstream from the air regulator.
- **Pump air regulator (F):** to control pump speed and outlet pressure. Locate it close to the pump.
- **Air line filter (J):** removes harmful dirt and moisture from compressed air supply.
- **Second bleed-type air valve (K):** isolates air line accessories for servicing. Locate upstream from all other air line accessories.

Hydraulic Line Accessories

For hydraulic-powered pumps, install the following accessories in the order shown in FIG. 2, using adapters as necessary.

- Use a minimum 13 mm (1/2 in.) ID **supply line (C)**, and a minimum 22 mm (7/8 in.) ID **return line (D)**. The motor has a 3/4 npt(f) hydraulic oil supply fitting, and a 1 in. npt(f) hydraulic oil return fitting.
- **Supply line shutoff valve (U)** isolates the pump for service.

- **Fluid pressure gauge (F)** monitors hydraulic oil pressure to the motor to avoid overpressurizing the motor or lower.
- **Pressure- and temperature-compensated flow control valve (G)** prevents the motor from running too fast and possibly damaging itself.
- **Pressure reducing valve (H) with a drain line (E)** runs directly to the hydraulic return line (D).
- **Accumulator (J)** reduces the hammering effect caused by the motor reversing direction.
- **Return line shutoff valve (V)** isolates the pump for service.
- Be sure your hydraulic power supply is equipped with a suction filter to the hydraulic pump and a **system return line filter (W)** of 10 micron size.
- Connect a 6 mm (1/4 in.) ID **drain line (K)** to the barbed fitting on the drip pan, and place the free end in a container to collect the drainage.

Fluid Line Accessories

Install the following accessories in the order shown in FIG. 1 and FIG. 2, using adapters as necessary.

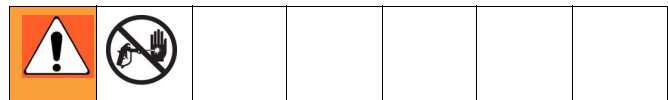

- **Fluid drain valve (M):** required in your system, to relieve fluid pressure in the hose and gun.
- **Fluid filter (L):** with a 60 mesh (250 micron) stainless steel element to filter particles from the fluid as it leaves the pump.
- **Gun or valve (S):** to dispense fluid.
- **Fluid line swivel (R):** for easier gun movement.
- **Suction kit (T):** enables the pump to draw fluid from a container.

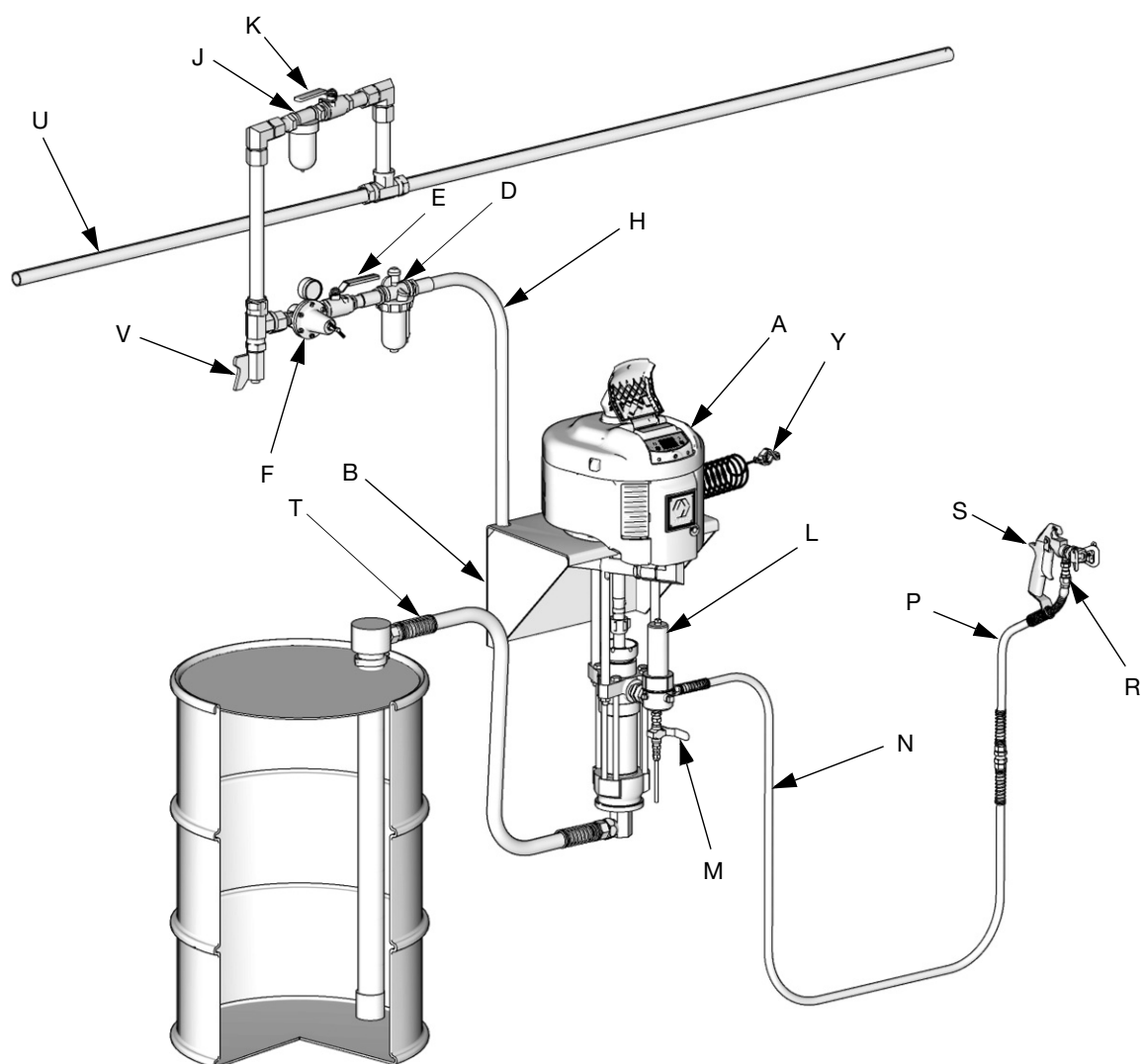

T18433a

FIG. 1: Typical Installation, Air-Powered Pumps

Key:

- | | |
|---|---|
| A Pump | N Electrically Conductive Fluid Supply Hose |
| B Wall Bracket | P Fluid Whip Hose |
| D Air Line Lubricator | R Gun Swivel |
| E Bleed-type Master Air Valve (required) | S Airless Spray Gun |
| F Pump Air Regulator | T Fluid Suction Kit |
| H Electrically Conductive Air Supply Hose | U Main Air Supply Line |
| J Air Line Filter | V Air Line Drain Valve |
| K Air Shutoff Valve | Y Pump Ground Wire (required, see page 9 for installation instructions) |
| L Fluid Filter | |
| M Fluid Drain Valve (required) | |

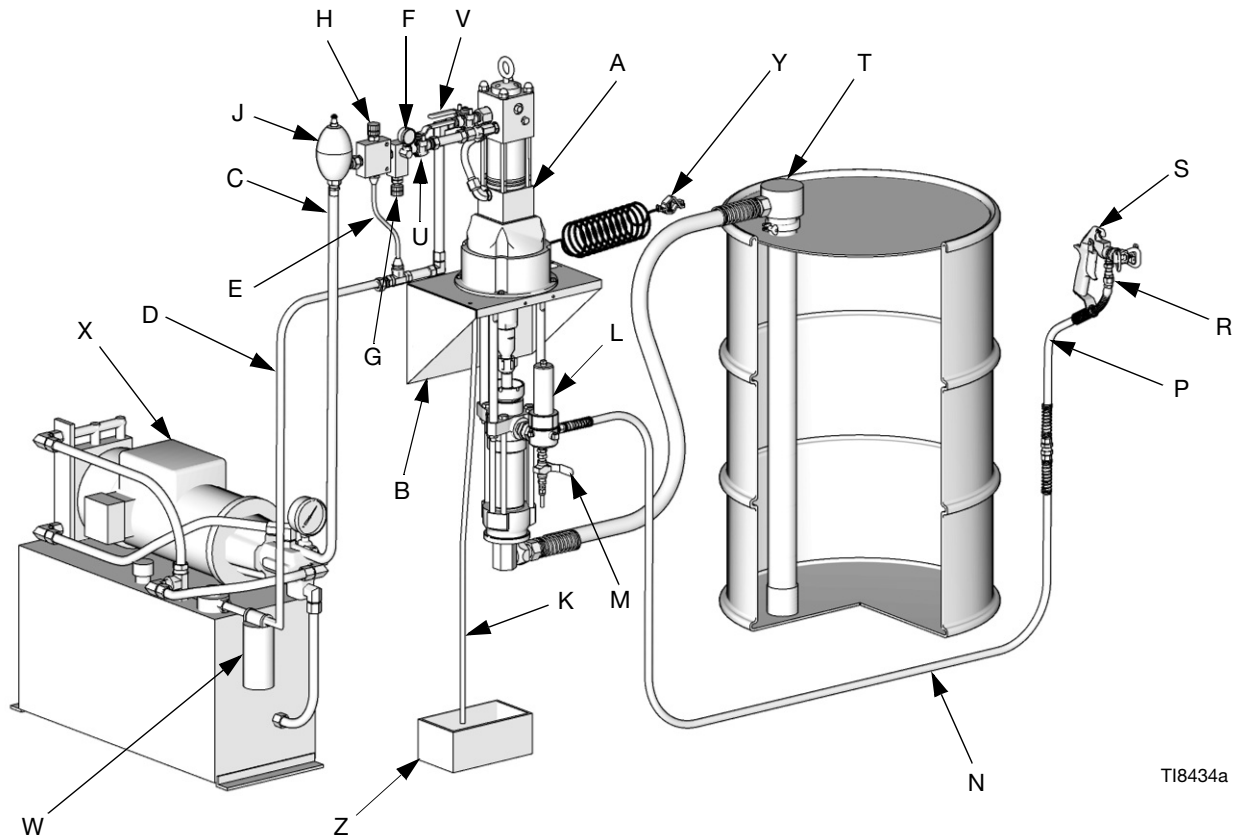

TI8434a





FIG. 2: Typical Installation, Hydraulic-Powered Pumps

Key:

- | | |
|---|---|
| A Pump | N Electrically Conductive Fluid Supply Hose |
| B Wall Bracket | P Fluid Whip Hose |
| C Hydraulic Supply Line | R Gun Swivel |
| D Hydraulic Return Line | S Airless Spray Gun |
| E Drain Line (from pressure reducing valve) | T Fluid Suction Kit |
| F Pressure Gauge | U Hydraulic Supply Line Shutoff Valve |
| G Flow Control Valve | V Hydraulic Return Line Shutoff Valve |
| H Pressure Reducing Valve | W Hydraulic Return Line Filter |
| J Accumulator | X Hydraulic Power Supply |
| K Drain Line (from motor drip pan) | Y Pump Ground Wire (required, see page 9 for installation instructions) |
| L Fluid Filter | Z Drainage Container |
| M Fluid Drain Valve (required) | |

Operation

Pressure Relief Procedure

						
<p>Trapped air can cause the pump to cycle unexpectedly, which could result in serious injury from splashing or moving parts.</p>						

1. Engage trigger lock.
2. Shutoff the pump:
 - a. *For air-powered pumps*, close the bleed-type master air valve.
 - b. *For hydraulic-powered pumps*, close the supply line shutoff valve (U) first, then close the return line shutoff valve (V).
3. Disengage the trigger lock.
4. Hold a metal part of the gun firmly to a grounded metal pail. Trigger the gun to relieve pressure.
5. Engage the trigger lock.
6. Open all fluid drain valves in the system, having a waste container ready to catch drainage. Leave drain valve(s) open until you are ready to spray again.
7. If you suspect the spray tip or hose is clogged or that pressure has not been fully relieved after following the steps above, **VERY SLOWLY** loosen tip guard retaining nut or hose end coupling to relieve pressure gradually, then loosen completely. Clear hose or tip obstruction.



Trigger Lock

Always engage the trigger lock when you stop spraying to prevent the gun from being triggered accidentally by hand or if dropped or bumped.

Startup

1. Connect the suction kit (T) to the pump's fluid inlet, and place the tube into the fluid supply.
2. Prepare the pump's power source:
 - a. *For air-powered pumps*, close the air regulator (F). Open the pump's bleed-type master air valve (E).
 - b. *For hydraulic-powered pumps*, check the hydraulic fluid level before each use, and add fluid as necessary. Close the supply line shutoff valve (U) and the return line shutoff valve (V). Start the hydraulic power supply.
3. Hold a metal part of the gun (S) firmly to the side of a grounded metal pail and hold the trigger open.
4. Start the pump:
 - a. *For air-powered pumps*, slowly open the air regulator until the pump starts.
 - b. *For hydraulic-powered pumps*, open the return line shutoff valve (V) first, then slowly open the supply line shutoff valve (U).

5. Cycle the pump slowly until all air is pushed out and the pump and hoses are fully primed. Release the gun trigger and lock the trigger safety latch. The pump should stall against pressure when the trigger is released.

						
Do not use your hand or fingers to cover the bleed hole on the underside of the bleeder valve body (AA) when priming the pump. Use a wrench to open and close the bleeder plug (AB). Keep your hands away from the bleed hole.						

6. If the pump fails to prime properly, open the bleeder valve plug (AB) slightly. Use the bleed hole as a priming valve until the fluid appears at the hole. See FIG. 3. Close the plug (AB).

 When changing fluid containers with the hose and gun already primed, open the bleeder valve plug (AB), to assist in priming the pump and venting air before it enters the hose. Close the bleeder valve when all air has been eliminated.

7. With the pump and lines primed, and with adequate air or hydraulic pressure and volume supplied, the pump will start and stop as the gun is opened and closed. In a circulating system, the pump will speed up or slow down on demand, until the air or hydraulic supply is shut off.
8. Always use the lowest air or hydraulic pressure necessary to get the desired results. Higher pressures cause premature tip/nozzle and pump wear.
 - a. For air-powered pumps, use the air regulator (F) to control the pump speed and fluid pressure.
 - b. For hydraulic-powered pumps, use the fluid pressure gauge (F) and flow control valve (G) to control the pump speed and the fluid pressure.
9. Never allow the pump to run dry of the fluid being pumped. A dry pump will quickly accelerate to a high speed, possibly damaging itself.

 If your pump accelerates quickly, or is running too fast, stop it immediately and check the fluid supply. If the supply container is empty and air has been pumped into the lines, refill the container and prime the pump and the lines with fluid, or flush and leave it filled with a compatible solvent. Be sure to eliminate all air from the fluid system.

Shutdown

						
---	---	--	--	--	--	--

Relieve the pressure, page 13. Stop the pump at the bottom of its stroke to prevent fluid from drying on the exposed displacement rod and damaging the throat packings.

 Bleed hole must face down.

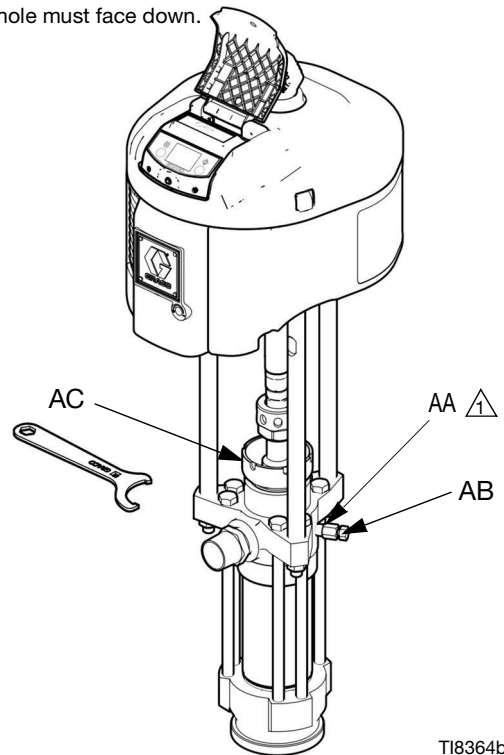

T18364b

FIG. 3. Bleeder Valve and Wet-Cup

Maintenance

Preventive Maintenance Schedule

The operating conditions of your particular system determine how often maintenance is required. Establish a preventive maintenance schedule by recording when and what kind of maintenance is needed, and then determine a regular schedule for checking your system.

Wet-Cups

See FIG. 3. Check the wet-cup (AC) daily. Keep the wet-cup 1/3 filled with Graco Throat Seal Liquid (TSL) or compatible solvent.

Using wrench (108) (order separately), adjust the packing nut weekly so it is just snug; do not overtighten. Torque to 135-169 N•m (100-125 ft-lb).

Flushing



- Flush before changing colors, before fluid can dry in the equipment, at the end of the day, before storing, and before repairing equipment.
- Flush at the lowest pressure possible. Check connectors for leaks and tighten as necessary.
- Flush with a fluid that is compatible with the fluid being dispensed and the equipment wetted parts.

1. Follow **Pressure Relief Procedure**, page 13.
2. Remove spray tip and soak in solvent.
3. Place siphon tube in grounded metal pail containing cleaning fluid.

4. Set pump to lowest possible fluid pressure, and start pump.
5. Hold a metal part of the gun firmly to a grounded metal pail. Trigger the gun until clean solvent dispenses.
6. Remove gun from hose. See gun manual to further clean gun.
7. Follow **Pressure Relief Procedure**, page 13, and remove fluid filter and soak in solvent. Replace filter cap.

Corrosion Protection

Always flush the pump before the fluid dries on the displacement rod. Never leave water or water-based fluid in the pump overnight. First, flush with water or a compatible solvent, then with mineral spirits. Relieve the pressure, but leave the mineral spirits in the pump to protect the parts from corrosion.

Hydraulic Systems

CAUTION

Keep the hydraulic supply system absolutely clean at all times. Blow out hydraulic lines with air and flush thoroughly with solvent before connecting to the hydraulic motor, to avoid introducing harmful contaminants into the motor. Plug the hydraulic lines immediately when they are disconnected.

Do not exceed 54°C (130°F) hydraulic oil temperature.

Carefully follow the manufacturer's recommendations on reservoir and filter cleaning, and periodic changes of hydraulic fluid. Use only Graco-approved hydraulic oil. Order Part No. 169236, 5 gal. (19 liter) or 207428, 1 gal. (3.8 liter). Do not substitute a lower grade oil or one with a lower flash point.

Troubleshooting

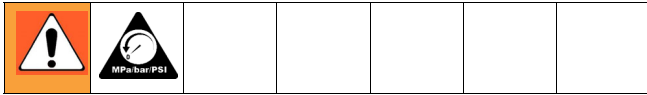

1. Relieve the pressure, page 13.
2. Check all possible causes and problems before disassembling the pump.

Problem	Cause	Solution
Pump fails to operate.	Restricted line or inadequate air/hydraulic supply; closed or clogged valves.	Clear; increase air/hydraulic supply. Check that valves are open.
	Obstructed fluid hose or gun/valve; fluid hose ID is too small.	Open, clear*; use hose with larger ID
	Fluid dried on displacement rod.	Clean; always stop pump at bottom of stroke; keep wet-cup 1/3 filled with compatible solvent.
	Dirty, worn, or damaged motor parts.	Clean or repair; see separate motor manual.
Pump operates, but output low on both strokes.	Restricted line or inadequate air/hydraulic supply; closed or clogged valves.	Clear; increase air/hydraulic supply. Check that valves are open.
	Obstructed fluid hose or gun/valve; fluid hose ID is too small.	Open, clear*; use hose with larger ID
	Bleeder valve open.	Close.
	Fluid too heavy for pump priming.	Use bleeder valve, page 14; use ram.
	Worn packings in lower.	Replace packings.
Pump operates, but output low on downstroke.	Held open or worn intake valve.	Clear valve; service.
	Fluid too heavy for pump priming.	Use bleeder valve, page 14; use ram.
Pump operates, but output low on upstroke.	Held open or worn piston valve or packings.	Clear valve; replace packings.
Erratic or accelerated pump speed.	Exhausted fluid supply.	Refill and prime.
	Fluid too heavy for pump priming.	Use bleeder valve, page 14; use ram.
	Held open or worn piston valve or packings.	Clear valve; replace packings.
	Held open or worn intake valve.	Clear valve; service.

* To determine if the fluid hose or gun is obstructed, relieve the pressure, page 13. Disconnect the fluid hose and place a container at the pump fluid outlet to catch any fluid. Turn on the air/hydraulic power just enough to start the pump. If the pump starts, the obstruction is in the fluid hose or gun.

Repair

Required Tools

- Set of socket wrenches
- Set of adjustable wrenches
- 24 in. adjustable wrench
- Torque wrench
- Thread lubricant
- Anti-seize lubricant 222955
- Loctite® 2760™ or equivalent

Disconnect the Lower

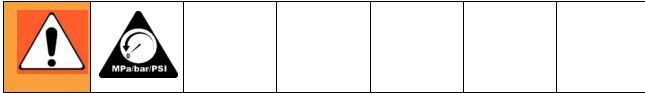

1. Flush the pump, if possible. Stop the pump at the bottom of its stroke. Relieve the pressure, page 13.
2. Disconnect the air or hydraulic hose. Plug all hydraulic hoses immediately, to prevent contamination of the hydraulic system.
3. Hold the fluid outlet fitting (AD) with a wrench to keep it from loosening while you disconnect the fluid hose. See FIG. 4.

CAUTION

Use at least two people when lifting, moving, or disconnecting the pump. If disconnecting the lower, be sure to securely brace the pump, or have two people hold it while another disconnects it.

 Before disconnecting the lower (102) from the motor (101), be sure to note the relative position of the pump's fluid outlet to the air or hydraulic inlet of the motor. If the motor does not require servicing, leave it attached to its mounting.

4. Unscrew the coupling nut (103) from the connecting rod adapter (105). Remove the coupling collars (104); do not to lose or drop them. See FIG. 4.
5. Hold the tie rod flats with a wrench to keep the rods (106) from turning. Unscrew the nuts (107). Remove the lower (102).
6. To service the lower, refer to manual 311825, supplied. To service the air or hydraulic motor, refer to the separate motor manual, supplied.

Reconnect the Lower

<p>Always use connecting rod adapter 184595 and tie rods 184596 on hydraulic-powered pumps. Other connecting rod adapters and tie rods do not allow sufficient clearance between the drip pan and coupling nut.</p>						

1. Screw the connecting rod adapter (105) to the air motor shaft. Torque as noted in FIG. 4.
2. Screw the tie rods (106) into the air motor (101). Using a wrench on the tie rod flats, torque as noted.
3. Make sure the coupling nut (103) and coupling collars (104) are in place on the displacement rod (DR).
4. Use at least two people to hold the lower while another reconnects it to the motor (see the **CAUTION**, page 17). Orient the pump's fluid outlet to the air or hydraulic inlet as noted under **Disconnect the Lower**. Place the lower (102) on the tie rods (106).

5. Screw the nuts (107) onto the tie rods (106) and torque as noted in FIG. 4.
6. Screw the coupling nut (103) onto the connecting rod adapter (105) loosely. Hold the connecting rod adapter flats with a wrench to keep it from turning. Use an adjustable wrench to tighten the coupling nut. Torque as noted in FIG. 4.
7. Torque the packing nut (PN) to 135-169 N•m (100-125 ft-lb).
8. Reconnect all hoses. Reconnect the ground wire if it was disconnected. Fill the wet-cup (PN) 1/3 full of Graco Throat Seal Liquid or compatible solvent.
9. Turn on the air or hydraulic power supply. On hydraulic pumps, open the hydraulic return line valve first, then the supply line valve. Run the pump slowly to ensure that it operates properly.

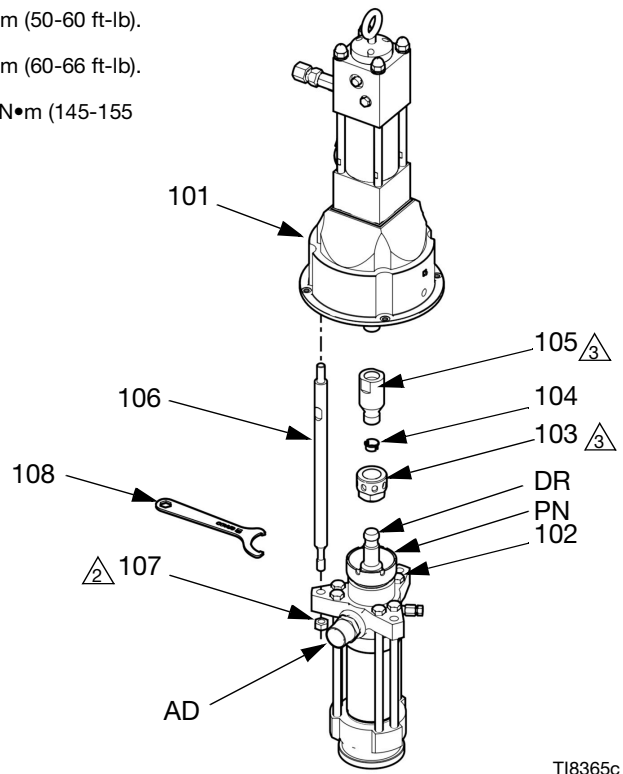
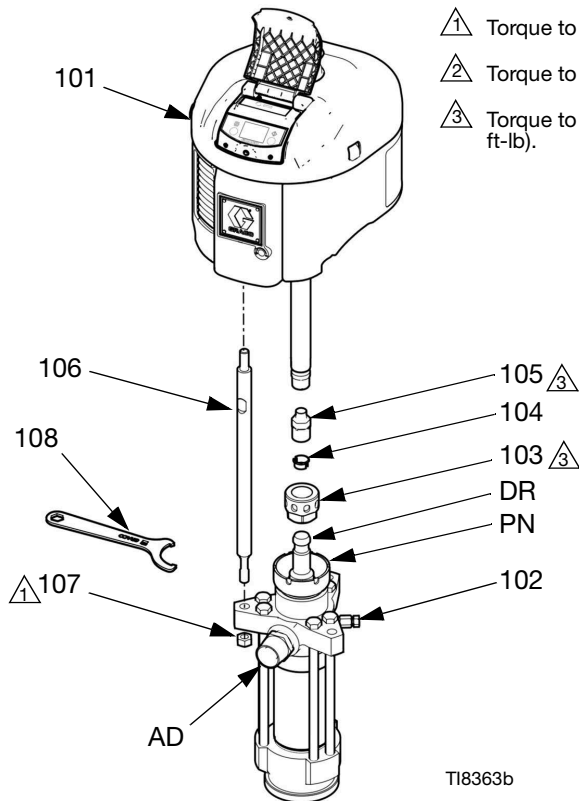

FIG. 4. Reconnect the Lower



A series of horizontal lines for writing, consisting of 20 evenly spaced lines that span the width of the page.

Parts

Dura-Flo Pumps with NXT Air Motors

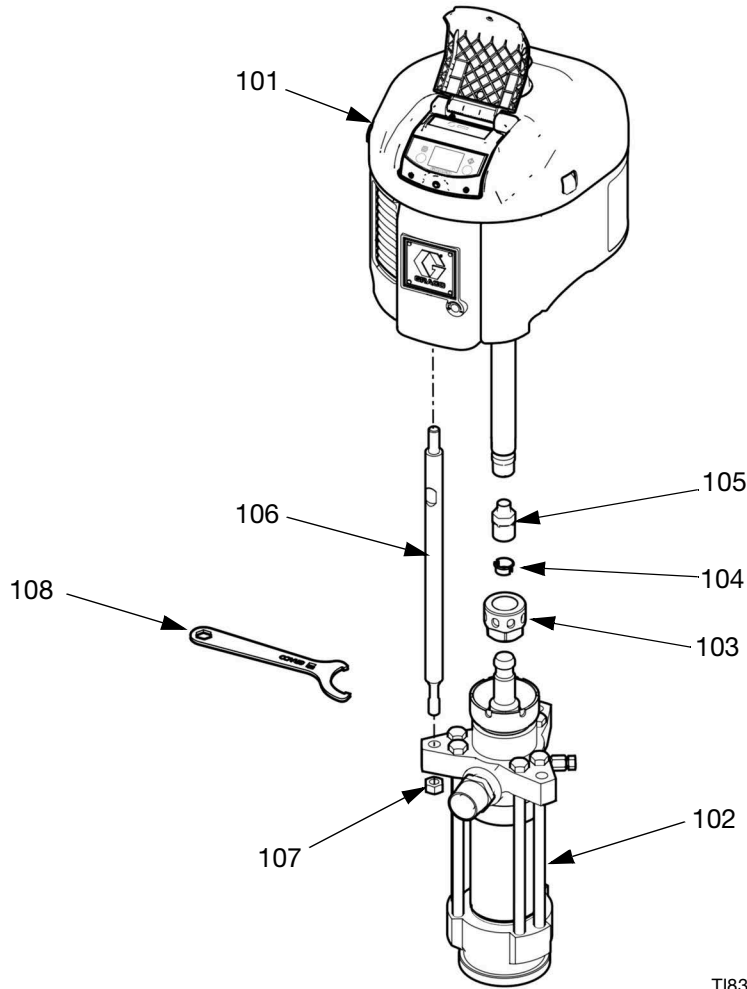

T18363b

Pump Part No.	Ref. Nos. and Descriptions									
	101	102	103	104	105	106	107	108	115	116
	MOTOR; see 311238	LOWER; see 311825	NUT, coupling	COLLAR, coupling	ADAPTER	ROD, tie	NUT, hex; 5/8-11	WRENCH	SHIELD, warning	SCREW; 8-32 x 2 in. (51 mm)
P12LCD	N34LN0	222801	184096	184130	15H371	15H562	101712	184278*	15H782	120094
P12LSA	N34LN0	222803								
P12MCD	N34LT0	222801								
P12MSA	N34LT0	222803								
P12DSA	N34LN0	222803								
P12ESA	N34LT0	222803								
P12HSM	N34LH0	L580SM								
P12DCD	N34LN0	222801								
P12HSS	N34LH0	L580SS								

Pump Part No.	Ref. Nos. and Descriptions									
	101	102	103	104	105	106	107	108	115	116
	MOTOR; see 311238	LOWER; see 311825	NUT, coupling	COLLAR, coupling	ADAPTER	ROD, tie	NUT, hex; 5/8-11	WRENCH	SHIELD, warning	SCREW; 8-32 x 2 in. (51 mm)
P12ECD	N34DT0	222801								
P12LSM	N34LN0	L580SM								
P12LSS	N34LN0	L580SS								
P15LCD	N34LN0	222796								
P15LSB	N34LN0	687055								
P15MCD	N34LT0	222796								
P15MSB	N34LT0	687055								
P15DSB	N34DN0	687055								
P15ESB	N34DN0	687055								
P15HSM	N34LH0	L430SM								
P15DCD	N34DN0	222796								
P15HSS	N34LH0	L430SS								
P15ECD	N34DT0	222796								
P15LSM	N34LN0	L430SM								
P15LSS	N34LN0	L430SS								
P22HSM	N34LH0	L580SM								
P22HSS	N65LH0	L580SS								
P22LCS	N65LN0	L580CS	184096	184130	15H371	15H562	101712	184278*	15H782	120094
P22LSM	N65LN0	L580SM								
P22LSS	N65LN0	L580SS								
P23DCD	N65DN0	222801								
P23ECD	N65DT0	222801								
P23LCD	N65LN0	222801								
P23LSA	N65LN0	222803								
P23MCD	N65LT0	222801								
P23MSA	N65LT0	222803								
P23DSA	N65DN0	222803								
P23ESA	N65DT0	222803								
P32DCD	N65DN0	222796								
P32ECD	N65DT0	222796								
P32HSM	N65LH0	L430SM								
P32LCD	N65LN0	222796								
P32HSS	N65LH0	L430SS								
P32LSB	N65LN0	687055								
P32LSM	N65LN0	L430SM								
P32MCD	N65LT0	222796								

Parts

Pump Part No.	Ref. Nos. and Descriptions									
	101	102	103	104	105	106	107	108	115	116
	MOTOR; see 311238	LOWER; see 311825	NUT, coupling	COLLAR, coupling	ADAPTER	ROD, tie	NUT, hex; 5/8-11	WRENCH	SHIELD, warning	SCREW; 8-32 x 2 in. (51 mm)
P32LSS	N65LN0	LH430SS	184096	184130	15H371	15H562	101712	184278*	15H782	120094
P32MSB	N65LT0	687055								
P32DSB	N65DN0	687055								
P32ESB	N65DT0	687055								
Qty	1	1	1	2	1	3	3	1		

** Sold separately

Dura-Flo Pumps with Viscount Hydraulic Motors

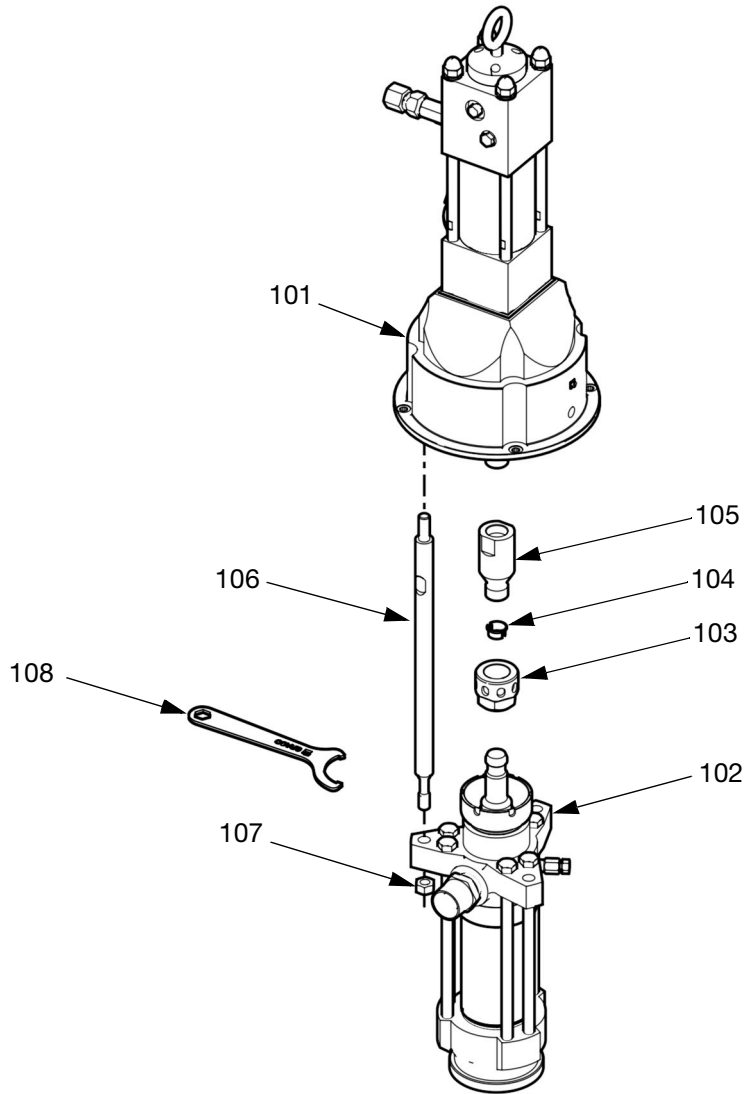

TI8365c

Pump Part No.	Ref. Nos. and Descriptions							
	101	102	103	104	105	106	107	108
	MOTOR; see 307158	LOWER; see 311825	NUT, coupling	COLLAR, coupling	ADAPTER	ROD, tie	NUT, hex; 5/8-11	WRENCH
222892	235345	222796	184096	184130	184595	184596	106166	184278*
222897		222805						
222834		222801						
222900		222803						
Qty	1	1	1	2	1	3	3	1

* Sold separately

Dura-Flo Pumps with Xtreme XL Air Motors

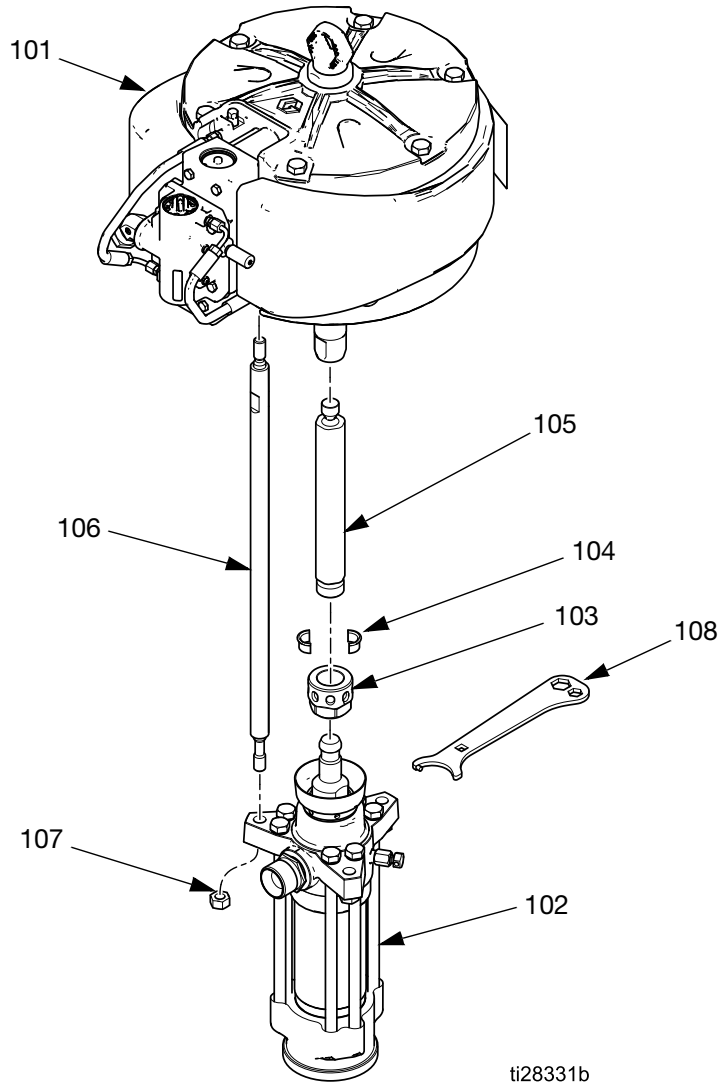

Pump Part No.	Ref. Nos. and Descriptions							
	101	102	103	104	105	106	107	108
	MOTOR; see 334644	LOWER; see 311825	NUT, coupling	COLLAR, coupling	ADAPTER	ROD, tie	NUT, hex; 5/8-11	WRENCH
P35LSS	24X856	L580SS	184096	184130	617463	617464	106166	184278*
P47LSS	24X856	L430SS						
P35LCS	24X856	L580CS	184096	184130	617463	617464	106166	184278*
P35LSM	24X856	L580SM						
P47LCS	24X856	L430CS	184096	184130	617463	617464	106166	184278*
P47LCM	24X856	L430CM						
P47LSM	24X856	L430SM						
Qty	1	1	1	2	1	3	3	1

* Sold separately

Dimensions

**Dura-Flo Pumps with
NXT Air Motors**

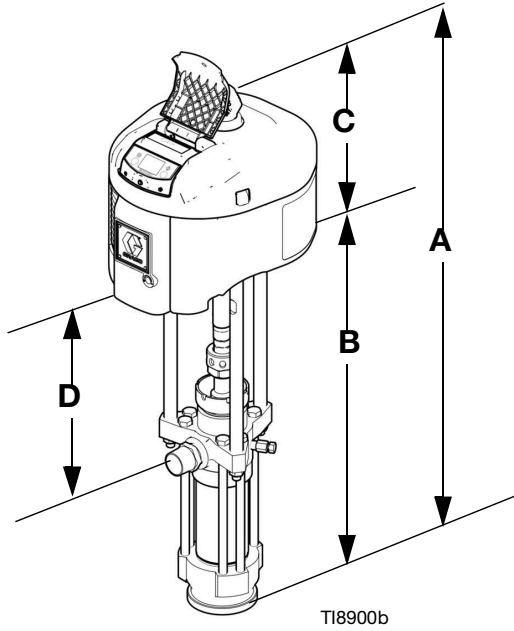

**Dura-Flo Pumps with
Viscount Hydraulic Motors**

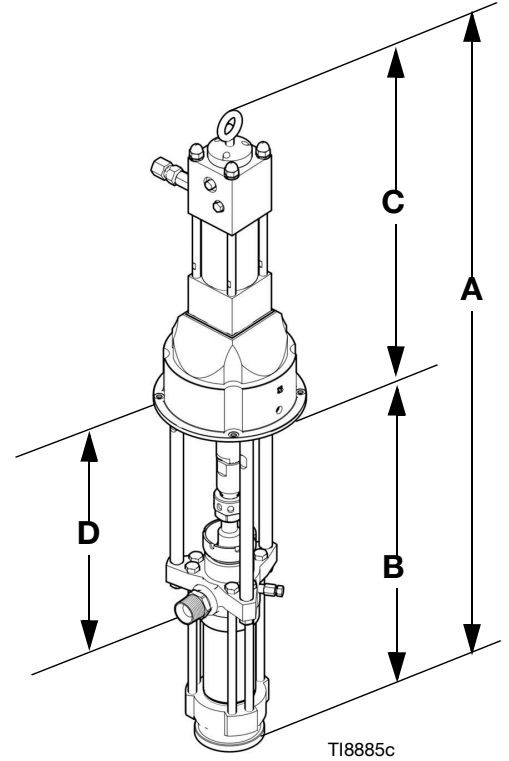

**Dura-Flo Pumps
with Xtreme XL
Motors**

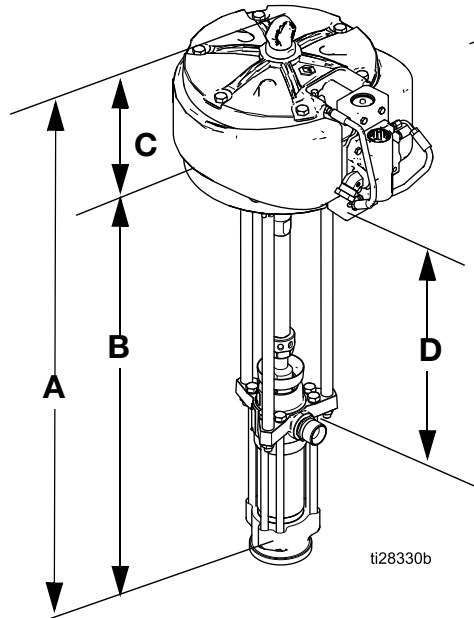

Motor Model	Pump Model	A mm (in.)	B mm (in.)	C mm (in.)	D mm (in.)	Weight kg (lb)
NXT Model 3400	All	1105 (43.5)	762 (30)	343 (13.5)	427 (16.8)	59 (130)
NXT Model 6500	All	1105 (43.5)	762 (30)	343 (13.5)	427 (16.8)	67.5 (149)
Viscount	All	1265 (49.8)	643 (25.3)	622 (24.5)	298 (11.7)	89 (196)
Xtreme XL	P35--- P47---	1371 (54)	1004 (39.5)	400 (15.75)	543 (21.38)	109 (240)

Mounting Hole Layouts

NXT Model 3400

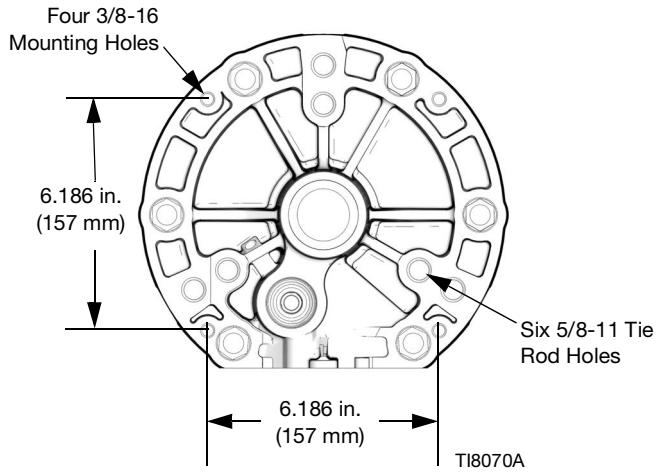

NXT Model 6500

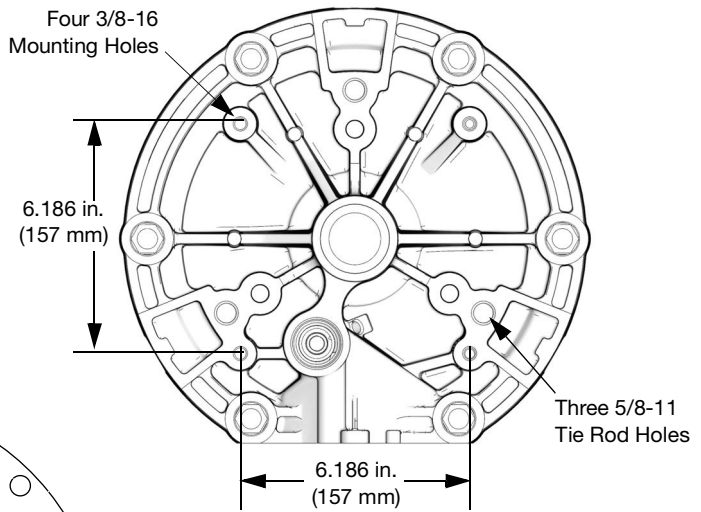

Viscount

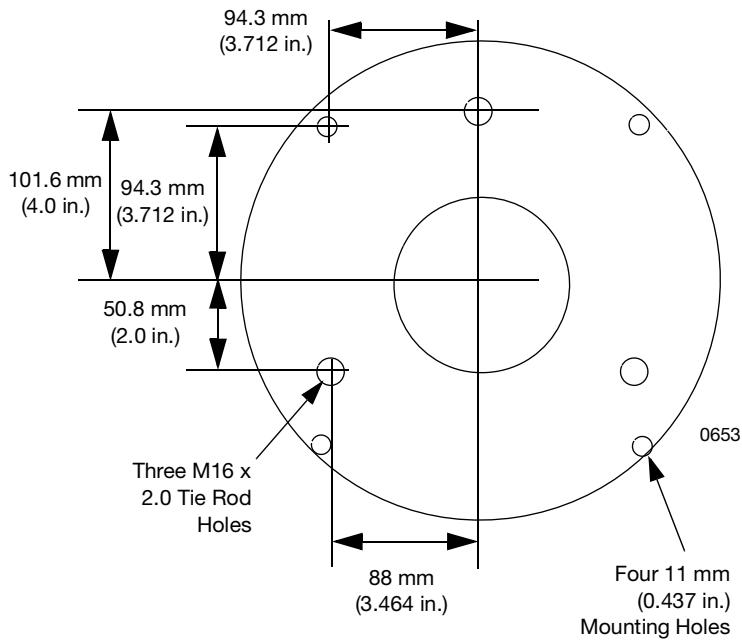

Xtreme XL

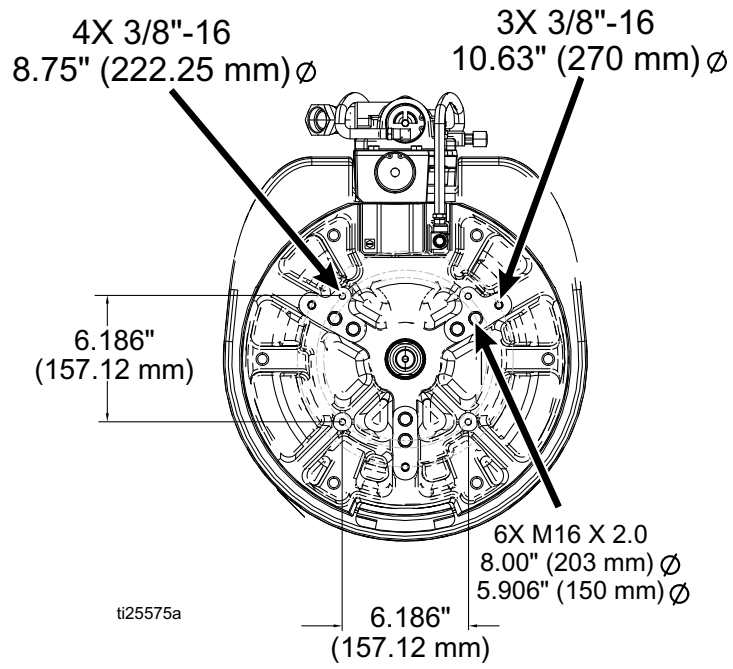

Technical Data

Ratio	See Models , page 3.
Maximum fluid working pressure	See Models , page 3.
Maximum air/hydraulic working pressure	See Models , page 3.
Pump cycles per 3.8 liters (1 gal.)	Dura-Flo 1800 (430 cc): 9.0 Dura-Flo 2400 (580 cc): 6.5
Fluid flow at 60 cpm.	Dura-Flo 1800 (430 cc): 26.1 liters/min (6.9 gpm) Dura-Flo 2400 (580 cc): 34.6 liters/min (9.2 gpm)
Motor piston effective area	See motor manual, supplied.
Stroke length	See motor manual, supplied.
Lower effective area.	Dura-Flo 1800 (430 cc): 18 cm ² (2.79 in. ²) Dura-Flo 2400 (580 cc): 24 cm ² (3.72 in. ²)
Maximum pump operating temperature	65.5°C (150°F)
Motor fitting sizes.	See motor manual, supplied.
Fluid inlet size.	2 in. npt(f)
Fluid outlet size	1-1/2 in. npt(m)
Sound pressure	NXT air motors: See manual 311238, supplied. Viscount hydraulic motors: 88 dB(A) at 1450 psi hydraulic pressure, 25 cycles/min (tested in accordance with ISO 3744) Xtreme XL air motor: 86.8 dB(A), tested 3.28 feet (1 m) from equipment.
Sound power	NXT air motors: See manual 311238, supplied. Viscount hydraulic motors: 103 dB(A) at 1450 psi hydraulic pressure, 25 cycles/min (tested in accordance with ISO 3744) Xtreme XL air motor: 96 dB(A), measured at 70 psi (0.48 MPa, 4.8 bar), 20 cpm, per ISO-9614-2.
Wetted parts.	See manual 311825.

Pump Performance Charts (see pages 29-32)

Fluid Outlet Pressure

To find fluid outlet pressure (MPa/bar/psi) at a specific flow (lpm/gpm) and operating pressure (A/B/C):

1. Locate desired flow at bottom of chart.
2. Follow vertical line up to intersection with selected operating pressure curve (solid line). Follow left to scale to read fluid outlet pressure.

Pump Air or Hydraulic Oil Consumption

To find air or hydraulic oil consumption at a specific flow (lpm/gpm) and operating pressure (A/B/C):

1. Locate desired flow at bottom of chart.
2. Follow vertical line up to intersection with selected operating pressure curve (dashed line). Follow left to scale to read air or oil consumption.

Key

- A** 0.7 MPa, 7 bar (100 psi) air pressure or 10.5 MPa, 105 bar (1500 psi) hydraulic oil pressure
 - B** 0.5 MPa, 4.9 bar (70 psi) air pressure or 7.5 MPa, 75 bar (1050 psi) hydraulic oil pressure
 - C** 0.3 MPa, 2.8 bar (40 psi) air pressure or 4.2 MPa, 42 bar (600 psi) hydraulic oil pressure
- Test Fluid:** No. 10 Weight Oil

Dura-Flo 1800 Pumps with NXT Model 3400 Air

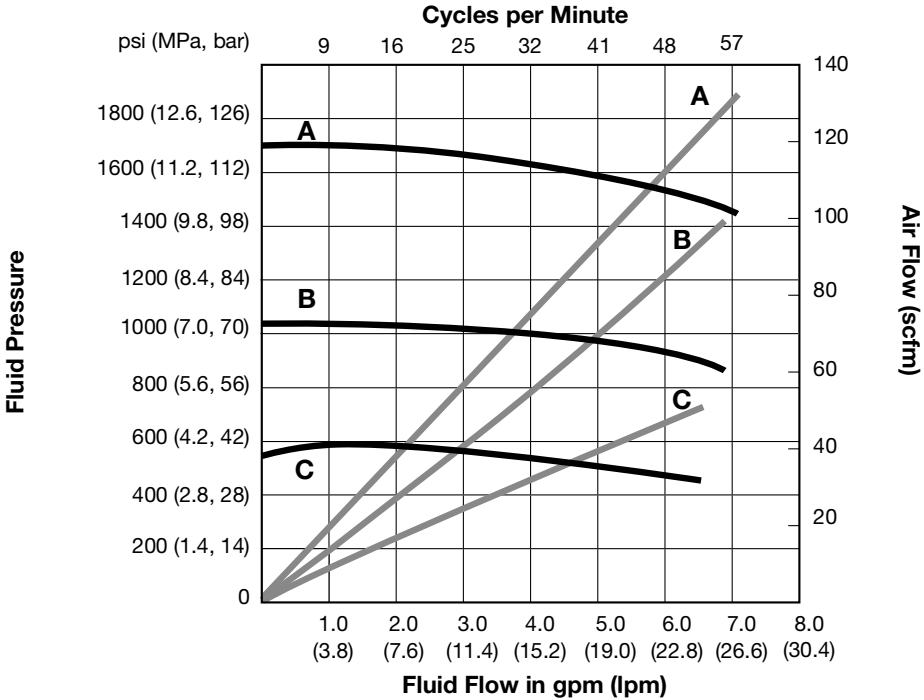

Dura-Flo 1800 Pumps with NXT Model 6500 Air

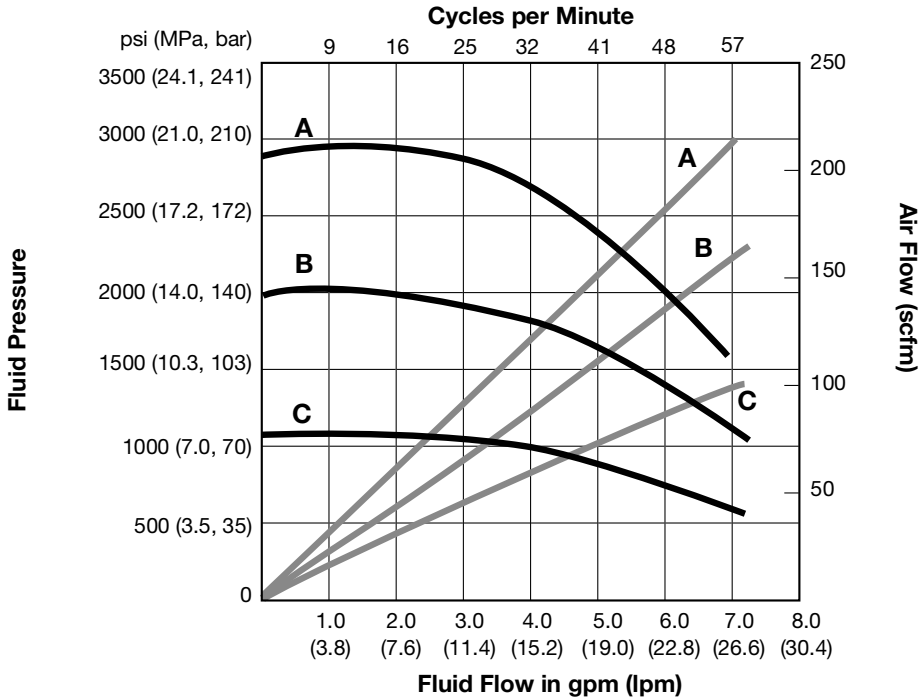

Key

- A** 0.7 MPa, 7 bar (100 psi) air pressure or 10.5 MPa, 105 bar (1500 psi) hydraulic oil pressure
 - B** 0.5 MPa, 4.9 bar (70 psi) air pressure or 7.5 MPa, 75 bar (1050 psi) hydraulic oil pressure
 - C** 0.3 MPa, 2.8 bar (40 psi) air pressure or 4.2 MPa, 42 bar (600 psi) hydraulic oil pressure
- Test Fluid:** No. 10 Weight Oil

Dura-Flo 1800 Pumps with Xtreme XL Air Motor

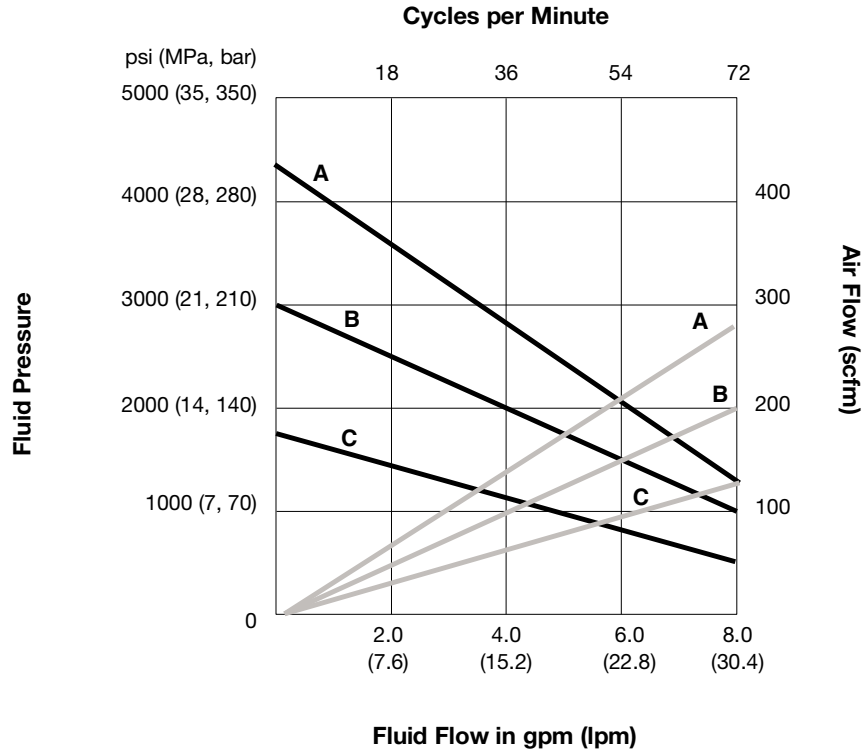

Dura-Flo 2400 Pumps with Xtreme XL Air Motor

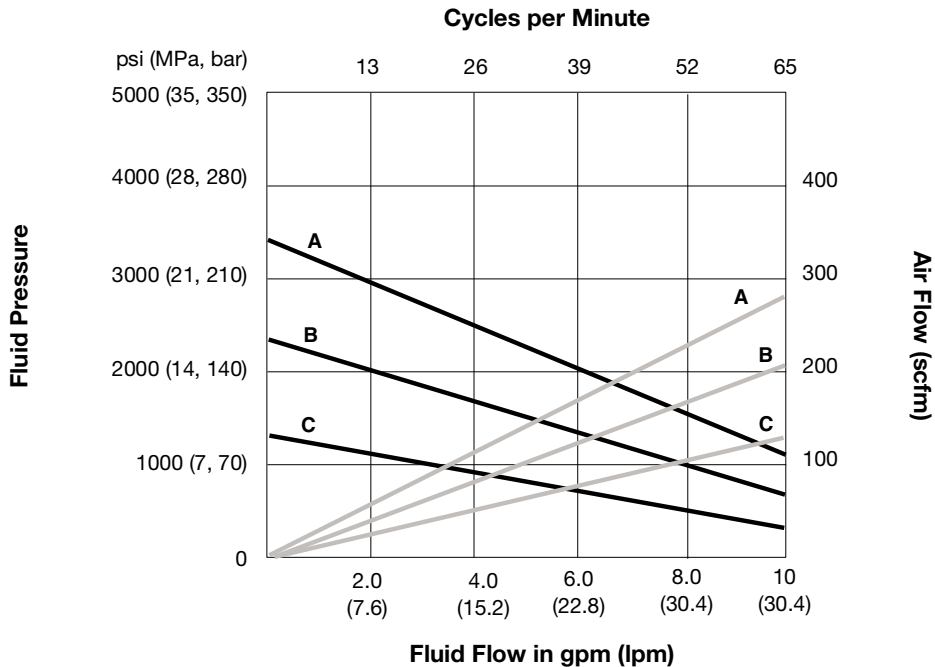

Key

- A** 0.7 MPa, 7 bar (100 psi) air pressure or 10.5 MPa, 105 bar (1500 psi) hydraulic oil pressure
 - B** 0.5 MPa, 4.9 bar (70 psi) air pressure or 7.5 MPa, 75 bar (1050 psi) hydraulic oil pressure
 - C** 0.3 MPa, 2.8 bar (40 psi) air pressure or 4.2 MPa, 42 bar (600 psi) hydraulic oil pressure
- Test Fluid:** No. 10 Weight Oil

Dura-Flo 2400 Pumps with NXT Model 3400 Air

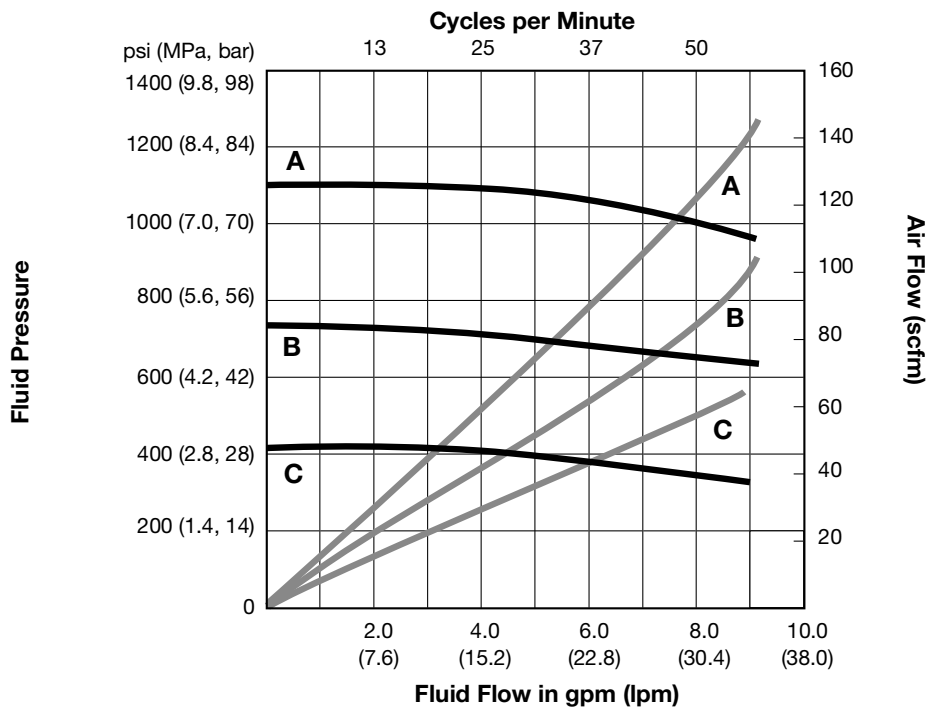

Dura-Flo 2400 Pumps with NXT Model 6500 Air

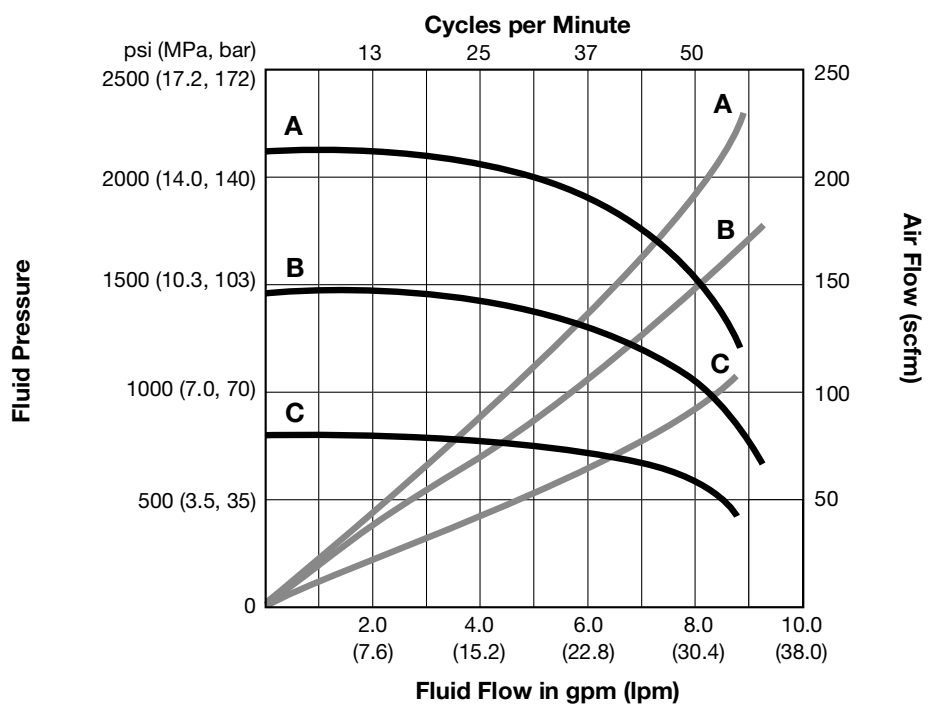

Key

- A** 0.7 MPa, 7 bar (100 psi) air pressure or 10.5 MPa, 105 bar (1500 psi) hydraulic oil pressure
 - B** 0.5 MPa, 4.9 bar (70 psi) air pressure or 7.5 MPa, 75 bar (1050 psi) hydraulic oil pressure
 - C** 0.3 MPa, 2.8 bar (40 psi) air pressure or 4.2 MPa, 42 bar (600 psi) hydraulic oil pressure
- Test Fluid:** No. 10 Weight Oil

Dura-Flo 1800 Pumps with Viscount Hydraulic Motors

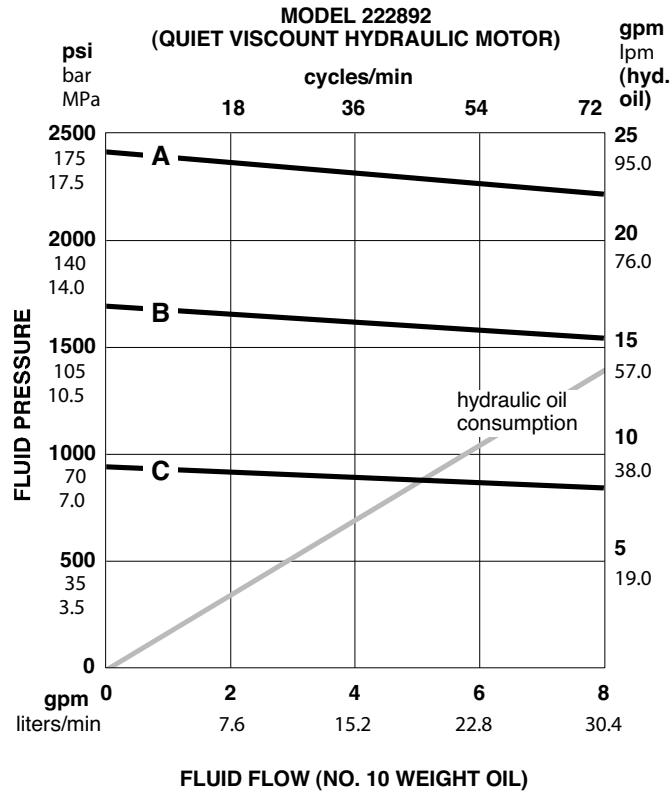

Dura-Flo 2400 Pumps with Viscount Hydraulic Motors

Test Fluid: No. 10 Weight Oil

Fluid Outlet Pressure

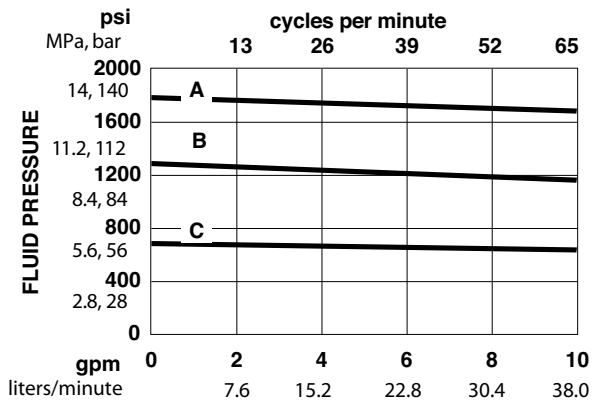

Hydraulic Oil Consumption

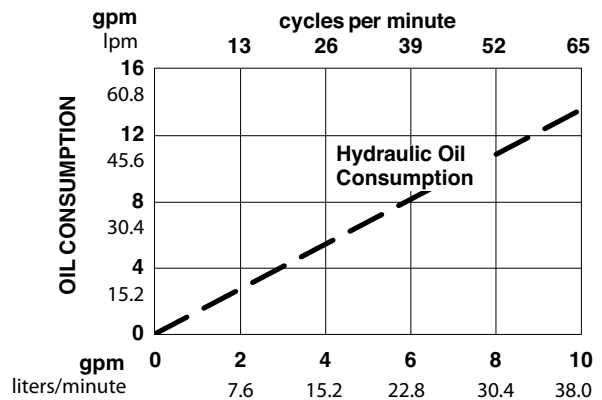



22 horizontal lines for technical drawing or text entry.

Graco Standard Warranty

Graco warrants all equipment referenced in this document which is manufactured by Graco and bearing its name to be free from defects in material and workmanship on the date of sale to the original purchaser for use. With the exception of any special, extended, or limited warranty published by Graco, Graco will, for a period of twelve months from the date of sale, repair or replace any part of the equipment determined by Graco to be defective. This warranty applies only when the equipment is installed, operated and maintained in accordance with Graco's written recommendations.

This warranty does not cover, and Graco shall not be liable for general wear and tear, or any malfunction, damage or wear caused by faulty installation, misapplication, abrasion, corrosion, inadequate or improper maintenance, negligence, accident, tampering, or substitution of non-Graco component parts. Nor shall Graco be liable for malfunction, damage or wear caused by the incompatibility of Graco equipment with structures, accessories, equipment or materials not supplied by Graco, or the improper design, manufacture, installation, operation or maintenance of structures, accessories, equipment or materials not supplied by Graco.

This warranty is conditioned upon the prepaid return of the equipment claimed to be defective to an authorized Graco distributor for verification of the claimed defect. If the claimed defect is verified, Graco will repair or replace free of charge any defective parts. The equipment will be returned to the original purchaser transportation prepaid. If inspection of the equipment does not disclose any defect in material or workmanship, repairs will be made at a reasonable charge, which charges may include the costs of parts, labor, and transportation.

THIS WARRANTY IS EXCLUSIVE, AND IS IN LIEU OF ANY OTHER WARRANTIES, EXPRESS OR IMPLIED, INCLUDING BUT NOT LIMITED TO WARRANTY OF MERCHANTABILITY OR WARRANTY OF FITNESS FOR A PARTICULAR PURPOSE.

Graco's sole obligation and buyer's sole remedy for any breach of warranty shall be as set forth above. The buyer agrees that no other remedy (including, but not limited to, incidental or consequential damages for lost profits, lost sales, injury to person or property, or any other incidental or consequential loss) shall be available. Any action for breach of warranty must be brought within two (2) years of the date of sale.

GRACO MAKES NO WARRANTY, AND DISCLAIMS ALL IMPLIED WARRANTIES OF MERCHANTABILITY AND FITNESS FOR A PARTICULAR PURPOSE, IN CONNECTION WITH ACCESSORIES, EQUIPMENT, MATERIALS OR COMPONENTS SOLD BUT NOT MANUFACTURED BY GRACO. These items sold, but not manufactured by Graco (such as electric motors, switches, hose, etc.), are subject to the warranty, if any, of their manufacturer. Graco will provide purchaser with reasonable assistance in making any claim for breach of these warranties.

In no event will Graco be liable for indirect, incidental, special or consequential damages resulting from Graco supplying equipment hereunder, or the furnishing, performance, or use of any products or other goods sold hereto, whether due to a breach of contract, breach of warranty, the negligence of Graco, or otherwise.

Graco Information

For the latest information about Graco products, visit www.graco.com.

For patent information, see www.graco.com/patents.

TO PLACE AN ORDER, contact your Graco distributor or call to identify the nearest distributor.

Phone: 612-623-6921 **or Toll Free:** 1-800-328-0211 **Fax:** 612-378-3505

*All written and visual data contained in this document reflects the latest product information available at the time of publication.
Graco reserves the right to make changes at any time without notice.*

Original instructions. This manual contains English. MM 311826

Graco Headquarters: Minneapolis

International Offices: Belgium, China, Japan, Korea

GRACO INC. AND SUBSIDIARIES • P.O. BOX 1441 • MINNEAPOLIS MN 55440-1441 • USA
Copyright 2006, Graco Inc. All Graco manufacturing locations are registered to ISO 9001.

www.graco.com

Revision M, April 2024