

Electric and Air-Powered Hot Melt Applicators

310803A

For dispensing non-explosive hot melt thermoplastic sealants and adhesives (see page 12).



Read warnings and instructions.

See page 2 for model information, including maximum working pressure.



EG Electric Applicator, with optional extrusion nozzle

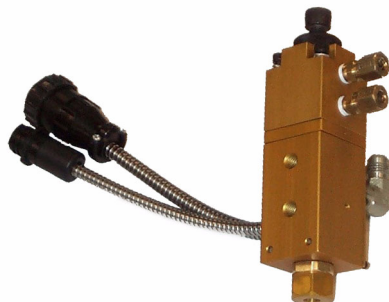

AG Air-Powered Applicator



VEA Applicator, with optional swirl assembly

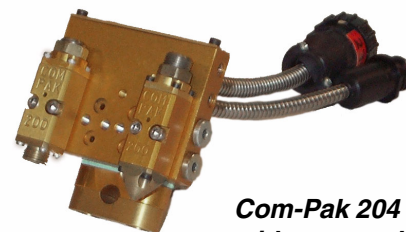

Com-Pak 204 Manifold, with two applicators

PROVEN QUALITY. LEADING TECHNOLOGY.

Contents

Models	2	Operation	12
Vertical Electric Applicators (VEA)	2	Pressure Relief Procedure	12
Automatic Electric Applicators (EG)	2	Flushing	12
Automatic Air-Powered Applicators (AG)	3	Maintenance	13
Com-Pak™ Automatic Air-Powered Applicators and Manifolds	3	Preventive Maintenance Schedule	13
Manual Conventions	3	Daily Maintenance	13
Related Manuals	3	Clean the Applicator	13
Warnings	4	Troubleshooting	14
Installation	6	Repair	16
Grounding	6	VEA and EG Applicators	16
Accessories	6	AG Applicator	20
Flush Before Using Equipment	6	Com-Pak Manifold	22
Heated Hose Connection	6	Parts	23
Air Spray and Swirl Applications	6	Accessories	30
Electric (EG, VEA) Applicators	7	Schematics	34
Air-Powered (AG) Applicators	9	Technical Data	37
Com-Pak Manifolds	11	Graco Standard Warranty	38
		Graco Information	38

Models

Vertical Electric Applicators (VEA)

Part No., Series	Maximum Working Pressure psi (MPa, bar)	Description
117842, A	3500 (23.3, 233)	115 Vac with 115 Vac Coil
117843, A	3500 (23.3, 233)	230 Vac with 230 Vac Coil
117844, A	3500 (23.3, 233)	230 Vac with 115 Vac Coil
117845, A	3500 (23.3, 233)	115 Vac with 24 Vdc Coil
117846, A	3500 (23.3, 233)	230 Vac with 24 Vdc Coil

Automatic Electric Applicators (EG)

Part No., Series	Maximum Working Pressure psi (MPa, bar)	Description
117847, A	3500 (23.3, 233)	230 Vac with 24 Vdc Coil
117848, A	3500 (23.3, 233)	115 Vac with 24 Vdc Coil
117849, A	3500 (23.3, 233)	115 Vac with 115 Vac Coil
117850, A	3500 (23.3, 233)	230 Vac with 230 Vac Coil
117851, A	3500 (23.3, 233)	230 Vac with 115 Vac Coil

Automatic Air-Powered Applicators (AG)

Part No., Series	Maximum Working Pressure psi (MPa, bar)	Description
118288, A	3500 (23.3, 233)	115 Vac
118289, A	3500 (23.3, 233)	230 Vac

Com-Pak™ Automatic Air-Powered Applicators and Manifolds

Part No., Series	Maximum Working Pressure psi (MPa, bar)	Description
117961, A	3500 (23.3, 233)	Com-Pak 201 Manifold, 115 Vac
117962, A	3500 (23.3, 233)	Com-Pak 201 Manifold, 230 Vac
117963, A	3500 (23.3, 233)	Com-Pak 202 Manifold, 115 Vac
117964, A	3500 (23.3, 233)	Com-Pak 202 Manifold, 230 Vac
117965, A	3500 (23.3, 233)	Com-Pak 204 Manifold, 115 Vac
117966, A	3500 (23.3, 233)	Com-Pak 204 Manifold, 230 Vac
118068, A	3500 (23.3, 233)	Com-Pak Applicator Module
118069, A	3500 (23.3, 233)	0 Cavity Module, 0.015 in. orifice
118070, A	3500 (23.3, 233)	0 Cavity Module, 0.020 in. orifice
118071, A	3500 (23.3, 233)	0 Cavity Module, 0.025 in. orifice

Manual Conventions

 **WARNING**

 Hazard Symbol

WARNING: a potentially hazardous situation which, if not avoided, could result in death or serious injury.

Warnings in the instructions usually include a symbol indicating the hazard. Read the general **Warnings** section for additional safety information.

CAUTION

CAUTION: a potentially hazardous situation which, if not avoided, may result in property damage or destruction of equipment.

Note





 Additional helpful information.







Related Manuals

Manual	Description
309831	THERM-O-FLOW® Hot Melt Tank T5
309832	THERM-O-FLOW® Hot Melt Tank T7
309833	THERM-O-FLOW® Hot Melt Tank T18
310814	EC-20/EC-40 Timer

Warnings

The following warnings include general safety information for this equipment. Further product specific warnings may be included in the text where applicable.

 WARNING	
	<p>ELECTRIC SHOCK HAZARD</p> <p>Improper grounding, setup, or usage of the system can cause electric shock.</p> <ul style="list-style-type: none"> • Turn off and disconnect power cord before servicing equipment. • Use only grounded electrical outlets. • Use only 3-wire extension cords. • Ensure ground prongs are intact on sprayer and extension cords.
	<p>BURN HAZARD</p> <p>Equipment surfaces and fluid that's heated can become very hot during operation. To avoid severe burns, do not touch hot fluid or equipment. Wait until equipment/fluid has cooled completely.</p>
	<p>INJECTION HAZARD</p> <p>High-pressure fluid from dispense valve, hose leaks, or ruptured components will pierce skin. This may look like just a cut, but it is a serious injury that can result in amputation. Get immediate medical attention.</p> <ul style="list-style-type: none"> • Do not point dispense valve at anyone or at any part of the body. • Do not put your hand over the end of the dispense nozzle. • Do not stop or deflect leaks with your hand, body, glove, or rag. • Follow Pressure Relief Procedure in this manual, when you stop spraying and before cleaning, checking, or servicing equipment.
	<p>EQUIPMENT MISUSE HAZARD</p> <p>Misuse can cause death or serious injury.</p> <ul style="list-style-type: none"> • Do not exceed the maximum working pressure or temperature rating of the lowest rated system component. See Technical Data in all equipment manuals. • Use fluids and solvents that are compatible with equipment wetted parts. See Technical Data in all equipment manuals. Read fluid and solvent manufacturer's warnings. • Check equipment daily. Repair or replace worn or damaged parts immediately. • Do not alter or modify equipment. • For professional use only. • Use equipment only for its intended purpose. Call your Graco distributor for information. • Route hoses and cables away from traffic areas, sharp edges, moving parts, and hot surfaces. • Do not use hoses to pull equipment. • Comply with all applicable safety regulations.

 WARNING	
	<p>TOXIC FLUID OR FUMES HAZARD</p> <p>Toxic fluids or fumes can cause serious injury or death if splashed in the eyes or on skin, inhaled, or swallowed.</p> <ul style="list-style-type: none"> • Read MSDS's to know the specific hazards of the fluids you are using. • Store hazardous fluid in approved containers, and dispose of it according to applicable guidelines.
	<p>PRESSURIZED ALUMINUM PARTS HAZARD</p> <p>Do not use 1,1,1-trichloroethane, methylene chloride, other halogenated hydrocarbon solvents or fluids containing such solvents in pressurized aluminum equipment. Such use can cause serious chemical reaction and equipment rupture, and result in death, serious injury, and property damage.</p>
  	<p>PERSONAL PROTECTIVE EQUIPMENT</p> <p>You must wear appropriate protective equipment when operating, servicing, or when in the operating area of the equipment to help protect you from serious injury, including eye injury, inhalation of toxic fumes, burns, and hearing loss. This equipment includes but is not limited to:</p> <ul style="list-style-type: none"> • Protective eyewear • Clothing and respirator as recommended by the fluid and solvent manufacturer • Gloves • Hearing protection

Installation

Grounding

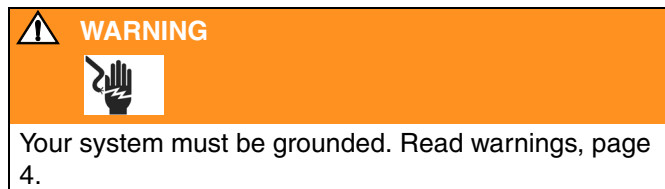

Ground the applicator through connection to a properly grounded fluid hose and hot melt tank. See your hot melt tank manual for further instructions.

Accessories

Install the following accessories in the order shown in FIG. 1 through FIG. 4, using adapters as necessary.

- **Heated Hose (D):** allows adhesive to flow from the tank to the applicator while maintaining the set temperature.
 - Extrusion Hose: for extrusion application. See page 30.
 - Spray/Swirl Hose: includes air line (N) in the hose jacket. See page 30.
- **Air Saver Control Unit (K):** for spray or swirl pattern applications. Adjusts and regulates air to the applicator. Order 118041 for 115 Vac systems or 118042 for 230 Vac systems.

Flush Before Using Equipment

The equipment was tested with hot melt, which is left in the fluid passages to protect parts. To avoid contaminating your fluid with this hot melt, purge the equipment with new hot melt, 118090 Purge Compound, or a compatible non-flammable solvent before using the equipment. See **Flushing**, page 12.

Heated Hose Connection

Connect the heated hose (D) to the applicator fluid inlet. Tighten securely with wrenches, one on the applicator inlet and one on the hose.

Align the keys of the heated hose cable connector (C) to the applicator's wiring assembly (B) connector, and securely screw the connectors together.

Air Spray and Swirl Applications

See FIG. 3, page 10. Air spray and swirl applications require installation of the Air Saver Control (K). Order 118041 for 115 Vac systems or 118042 for 230 Vac systems. Also order the air spray or swirl adapter (P) and the desired nozzle. See the charts on page 30 for available nozzles.

Remove the nozzle nut and screw the spray or swirl adapter (P) onto the applicator (A). Tighten securely. Do not install the nozzle yet.

Bring an air supply line (M) to the air inlet at the back of the air saver control (K). Do not turn the air on yet.

Connect the air line (N) from the heated hose (D) to the air output on the front of the air saver control (K). Connect the tube from the air spray or swirl adapter (P) to the other end of the hose air line.

Connect the electrical cable (L) from the air saver control (K) to the auxiliary receptacle on the hot melt tank (E) or to a timer (F), if used. To operate the air saver control, you must set the auxiliary control; see the hot melt tank manual.

Electric (EG, VEA) Applicators

See FIG. 1 for EG Applicators and FIG. 2 for VEA Applicators.

Connect the heated hose (D) and hose electrical connector (C) as explained on page 6.

For EG applicators, see FIG. 1. Connect a starting device such as a footswitch (H) to the timer (F). Connect a cord (G) from the timer (F) to the auxiliary receptacle on the hot melt tank (E). To operate the timer, you must set the auxiliary control; see the hot melt tank manual.

For VEA applicators, see FIG. 2 on page 8. Connect a cord (G) from the timer (F) to the auxiliary receptacle on the hot melt tank (E). To operate the timer, you must set the auxiliary control; see the hot melt tank manual. Connect a 3-way cord (J) from the two pushbutton (H) connectors and the applicator wiring assembly (B) to the hose electrical connector (C).

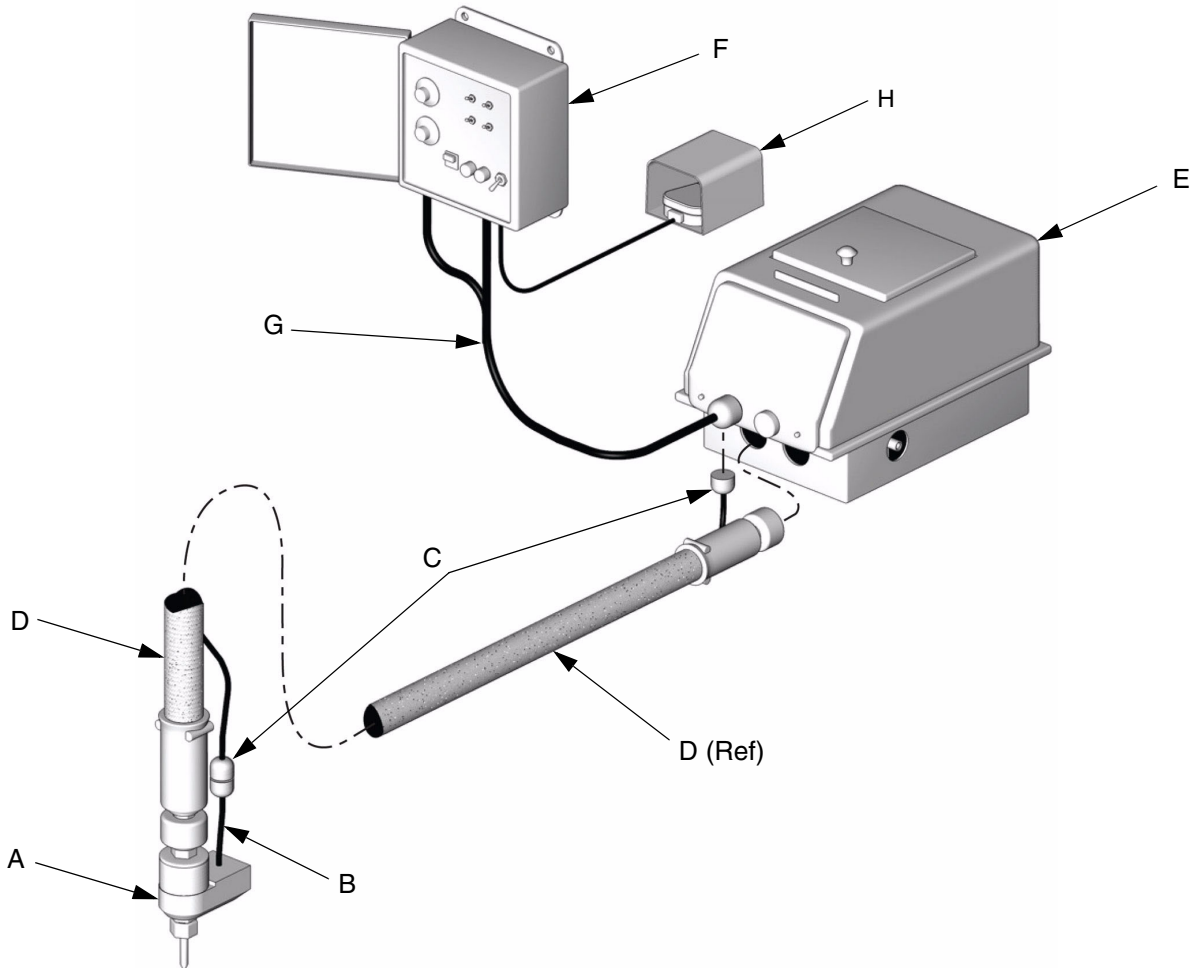

T16281a

FIG. 1: Typical Installation, Automatic Electric Extrusion System

Key:

- A EG Electric Applicator
- B Applicator Wiring Assembly
- C Hose Electrical Connector
- D Heated Hose

- E Hot Melt Tank (Model T7 shown)
- F Timer
- G Timer to Tank Power Cord
- H Footswitch

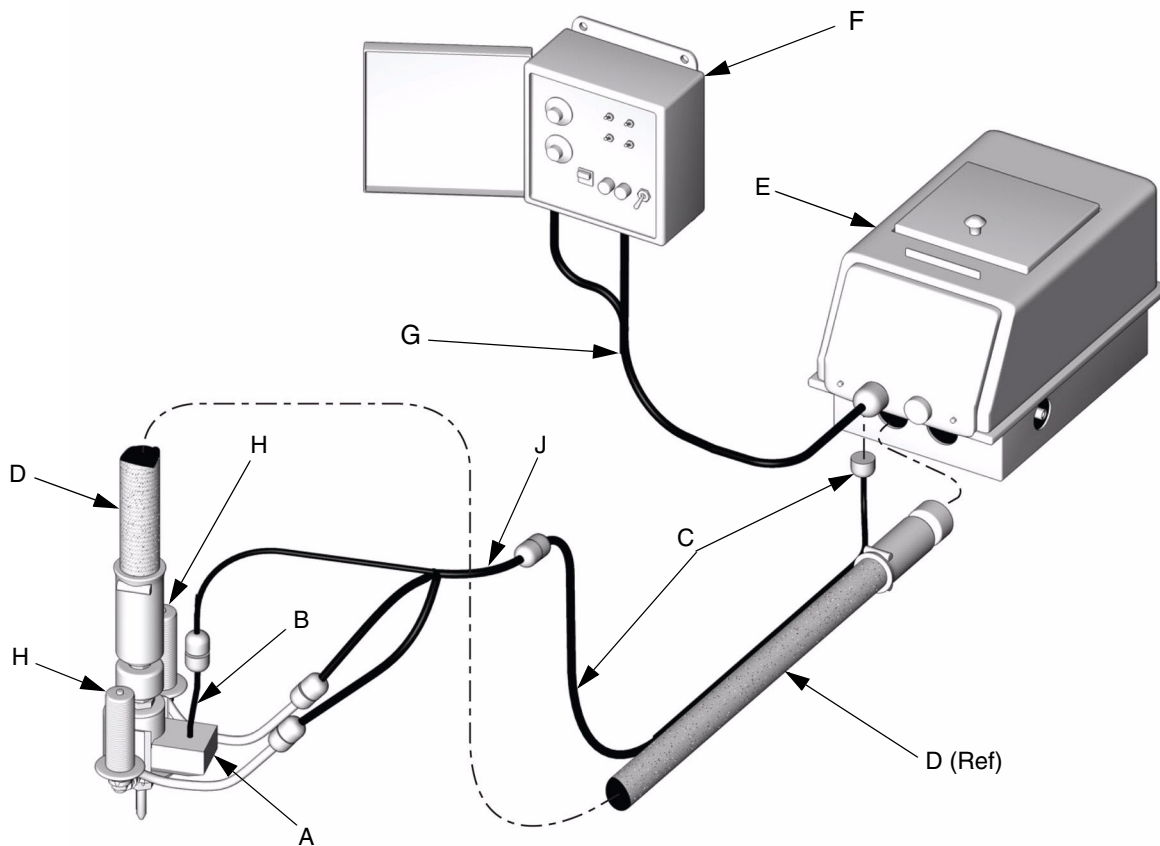

T16284a

FIG. 2: Typical Installation, Vertical Electric Extrusion System

Key:

- | | | | |
|---|--------------------------------|---|--|
| A | VEA Applicator | F | Timer |
| B | Applicator Wiring Assembly | G | Timer to Tank Power Cord |
| C | Hose Electrical Connector | H | Manual Pushbutton Controls and Handles |
| D | Heated Hose | J | 3-Way Electrical Connection to Hose |
| E | Hot Melt Tank (Model T7 shown) | | |

Air-Powered (AG) Applicators

See FIG. 3. Connect the heated hose (D) and hose electrical connector (C) as explained on page 6.

FIG. 3 shows a swirl application using a timer (F). See **Air Spray and Swirl Applications**, page 6.

Connect a starting device such as a footswitch (H) to the timer (F). Connect a cord (G) from the timer (F) to the auxiliary receptacle on the hot melt tank (E). To operate the timer, you must set the auxiliary control; see the hot melt tank manual.

Air-powered (AG) applicators require installation of a 4-way solenoid valve (R) to open and close the applicator. See Table 1 to select the correct solenoid valve for your application.

Connect the solenoid valve outputs to the applicator inputs, using the metal tubes (T, U) supplied with the solenoid valve. Tighten the ferrule nuts securely at all connections.

Connect the solenoid valve electrical connector (S) to the mating connector on the applicator.

Connect a filtered, regulated main air supply line (V) to the inlet of the solenoid valve. If desired, connect an air exhaust line to the solenoid exhaust port.

Table 1: Solenoid Valves for AG Applicators

Solenoid Valve Part No.	Type	Voltage
117997	4-way	24 Vdc
117998	4-way	115 Vac
117999	4-way	230 Vac

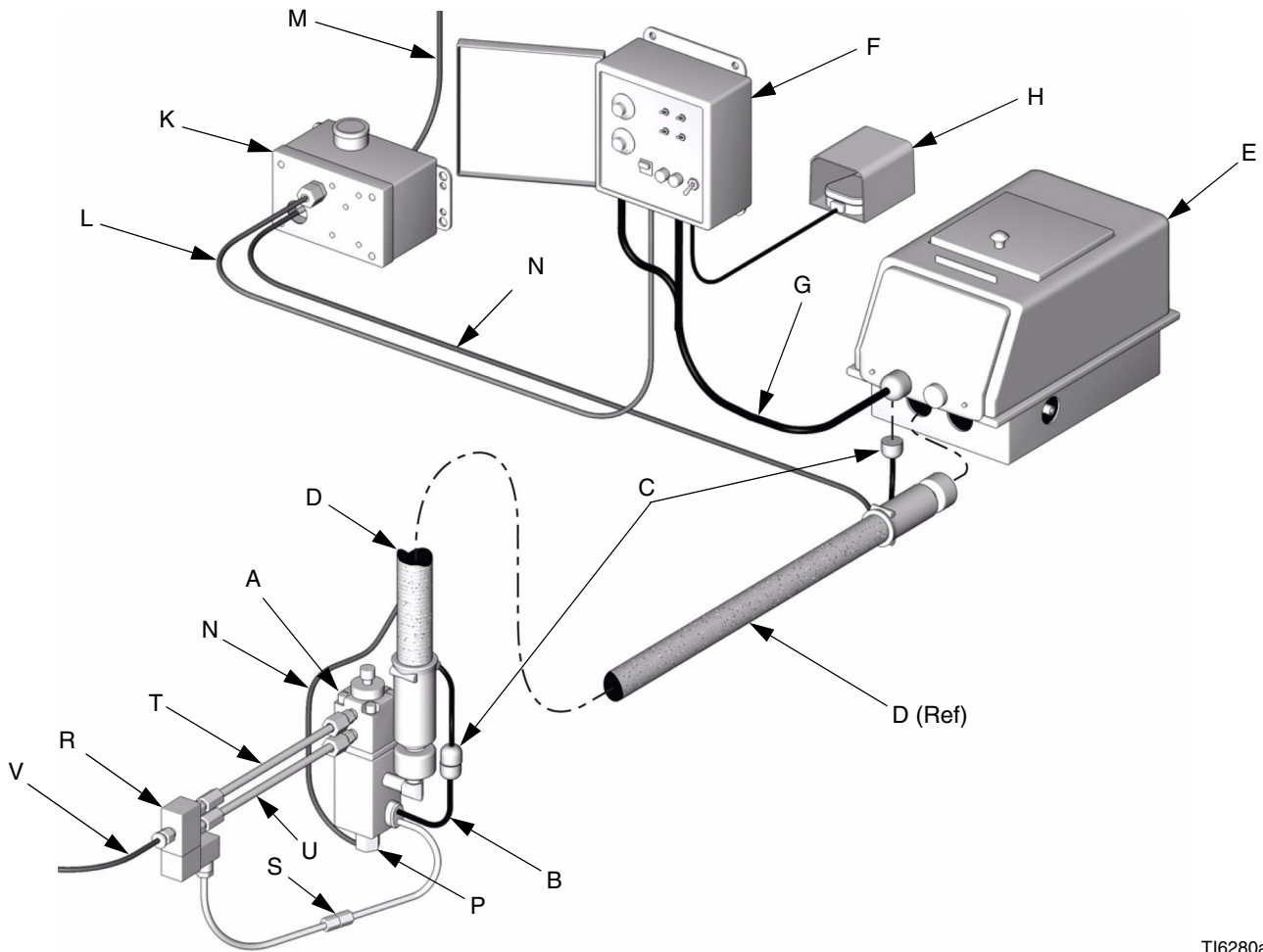

T16280a

Fig. 3: Typical Installation, Automatic Air-powered Swirl System

- Key:**
- | | | | |
|---|---|---|---|
| A | AG Applicator | M | Air Saver Control Air Supply Line |
| B | Applicator Wiring Assembly | N | Applicator Air Supply Line (required for airspray and swirl) |
| C | Hose Electrical Connector | P | Optional Swirl Assembly |
| D | Heated Hose | R | 4-Way Solenoid Valve |
| E | Hot Melt Tank (Model T7 shown) | S | Solenoid Valve Electrical Connection |
| F | Timer | T | Applicator Air On |
| G | Timer to Tank Power Cord | U | Applicator Air Off |
| H | Footswitch | V | Solenoid Air Supply Line (air must be filtered and regulated) |
| K | Air Saver Control (required for airspray and swirl) | | |
| L | Air Saver Control Electrical Connection | | |

Com-Pak Manifolds

See FIG. 4. Connect the heated hose (D) and hose electrical connector (C) as explained on page 6.

Connect a starting device such as a footswitch (H) to the timer (F). Connect a cord (G) from the timer (F) to the auxiliary receptacle on the hot melt tank (E). To operate the timer, you must set the auxiliary control; see the hot melt tank manual.

Com-Pak manifolds require installation of a 3-way solenoid valve (W) to open the applicators. See Table 2 to select the correct solenoid valve for your application.

Connect the solenoid valve output to the manifold input, using the metal tube (T) supplied with the solenoid valve. Tighten the ferrule nuts securely at all connections.

Connect the solenoid valve electrical connector (S) to the mating connector on the manifold.

Connect the main air supply line (V) to the inlet of the solenoid valve. If desired, connect an air exhaust line to the solenoid exhaust port.

Table 2: Solenoid Valves for Com-Pak Applicators

Solenoid Valve Part No.	Type	Voltage
117994	3-way	24 Vdc
117995	3-way	115 Vac
117996	3-way	230 Vac

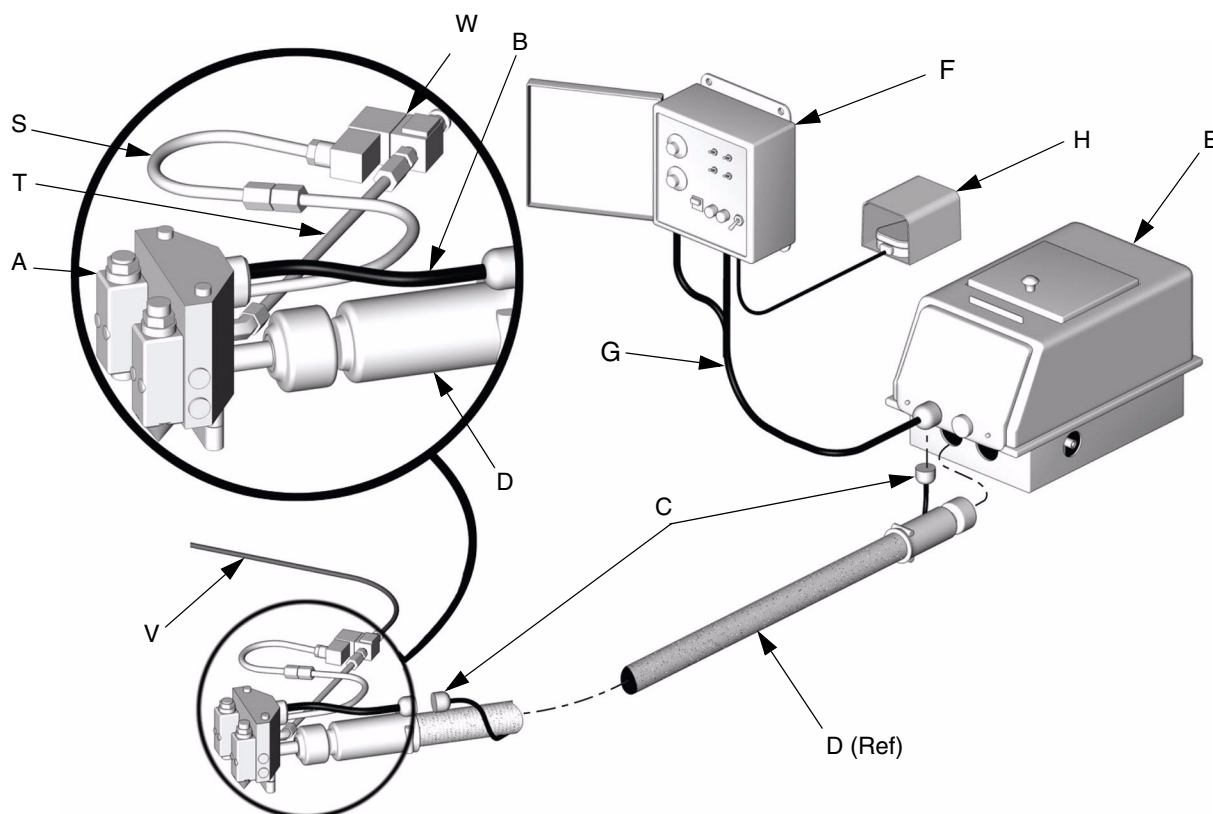

T16282a

FIG. 4: Typical Installation, Com-Pak System

Key:



- A Com-Pak 204 Manifold and Applicators
- B Manifold Wiring Assembly
- C Hose Electrical Connector
- D Heated Hose
- E Hot Melt Tank (Model T7 shown)
- F Timer

- G Timer to Tank Power Cord
- H Footswitch
- S Solenoid Valve Electrical Connection
- T Applicator Air On
- V Solenoid Air Supply Line
- W 3-Way Solenoid Valve

Operation

Pressure Relief Procedure

 **WARNING**

  

Follow **Pressure Relief Procedure** when you stop spraying and before cleaning, checking, servicing, or transporting equipment. Read warnings, page 4.

1. Shut off pump motor.
2. Actuate applicator, dispensing material into an empty pail, until material stops dispensing through the applicator.
3. If you suspect the nozzle or hose is clogged or that pressure has not been fully relieved after following the steps above, **VERY SLOWLY** loosen nozzle retaining nut or hose end coupling to relieve pressure gradually, then loosen completely. Clear hose or nozzle obstruction.

Flushing

 **WARNING**



This equipment is designed for use with standard adhesive and sealant such as EVA's, butyls, and polyolefins with flash points above 450°F (232°C). Not recommended for water curable or solvent based adhesive. Do not use flammable material or material not compatible with the specifications of this equipment. Failure to follow this instruction can cause injury to operators and damage to equipment.



- Flush before changing materials.
 - Flush at the lowest pressure possible. Check connectors for leaks and tighten as necessary.
 - Flush with 118090 Purge Compound.
1. Follow **Pressure Relief Procedure**, page 12.
 2. Remove nozzle and seat, and clean in compound.
 3. Flush system, following **Flushing** procedure given in hot melt tank manual. Trigger the applicator until clean compound dispenses.
 4. Follow **Pressure Relief Procedure**, page 12.
 5. Remove applicator from hose. See **Clean the Applicator**, page 13.

Maintenance

Preventive Maintenance Schedule

Establish a preventive maintenance schedule, based on the equipment's repair history.

Daily Maintenance

Before using the applicator, perform the following checks.

1. Wipe off all excess adhesive from all surfaces with 118090 Purge Compound.
2. Check the hoses, applicator heads, and nozzles for wear and ensure integrity of all electrical connections.
3. Verify the hose is being properly supported so it is not over-stressed during use. The minimum bend diameter is 16 in. (41 cm) when hot.

4. Look for leaks under the melt unit and at all mechanical connections.
5. Tighten all threaded connections before each use.

Clean the Applicator

WARNING



Applicator cannot be cleaned if material has cooled. Using a heat gun, heat the parts before disassembling. Wear gloves when handling heated parts.

1. Follow **Pressure Relief Procedure**, page 12.
2. Remove nozzle and seat, and clean in compound.
3. Disassemble the applicator as explained in the applicable section under **Repair**, page 16.
4. Reassemble in reverse order.

Troubleshooting

Problem	Cause	Solution
Applicator head not heating.	Applicator head not turned on at hot melt tank panel.	Turn on.
	Applicator not plugged in.	Plug applicator cable into hose connector.
	Incorrect voltage.	Check that power supply is correct voltage for equipment.
	Applicator temperature is too low.	Increase applicator temperature setting; see tank manual.
	Tank temperature too low.	Increase tank temperature setting; see tank manual.
	Improper mating of pin connection.	Inspect pins and remove strain relief. Inspect wiring for damage.
	Bad connection at hot melt tank circuit boards.	Inspect circuit board connections; see tank manual.
	Bad hot melt tank fuses.	Check fuses for continuity.
	Bad hose heater wire.	Check for continuity between pins 7 and 9 of 9 pin connector.
	Temperature sensor is open or not functioning correctly (open sensor light is lit on tank).	Reading should be approximately 100 K ohms between pins 1 and 2 of 9 pin connector. Replace wiring assembly.
	Applicator heater is damaged.	Replace wiring assembly.
Low or no flow of material from unit.	No power to tank.	Plug in tank. Turn on/off switch ON.
	Front panel settings not properly set.	See tank manual.
	Not enough material in tank.	Add material. See tank manual.
	Viscosity of material too high; tank temperature too low.	Increase temperature settings. Reference material manufacturer's instruction. Adjust controls, see tank manual.
		Increase orifice size.
	Applicator nozzle plugged.	Clean nozzle or replace.
	Hose is kinked or bent.	Check for kinks in hose, replace if damaged. See tank manual.
	Pump damaged.	Replace pump, see tank manual.
	Temperature sensor is open or not functioning correctly (open sensor light is lit on tank).	Reading should be approximately 100 K ohms between pins 1 and 2 of 9 pin connector. Replace wiring assembly.

Problem	Cause	Solution
Material leaks from nozzle.	Damaged or dirty needle or seat.	Clean or replace needle assembly and/or seat.
Material leaks from applicator body weep hole (AG and Com-Pak applicators only).	Damaged seals or piston.	Repair AG applicator, page 20. Replace Com-Pak applicator, page 22.
Material leaks from hose connection.	Threads at hose connection not seated properly.	Tighten connection. Clean threads by heating or using 118090 Purge Compound.
	Damaged swivel o-rings.	Replace swivel.
Com-Pak applicators are not shutting off simultaneously.	Applicators need adjustment.	See Adjust Applicator Actuation , page 22.

Repair

VEA and EG Applicators

Remove Control Handles (VEA Units Only)

1. Follow **Pressure Relief Procedure**, page 12. Shut off tank power and unplug power cord. Remove hose from applicator. Allow parts to cool before disassembling.

 See FIG. 5. Before removing the shield (29) and brackets (30, 36), note the orientation of the brackets to the applicator. Also note that the thickest insulators (31) are contacting the applicator.

2. Remove the screws (33), washers (34, 35), and insulators (31, 32). Disassemble the control handles (28), shield (29) and brackets (30, 36) from the applicator body (1).
3. Reassemble in reverse order, making sure the brackets (30, 36) are correctly oriented and the thick insulators (31) contact the applicator body (1).

Replace Heater/Sensor Wiring Assembly

 The wiring assembly (10) includes two heaters and one temperature sensor, which are not available separately.

1. Follow **Pressure Relief Procedure**, page 12. Shut off tank power and unplug power cord. Remove hose from applicator. Allow parts to cool before disassembling.
2. Disconnect applicator wire connector from hose connector.
3. See FIG. 6, page 19. Using 3/32 allen wrench, remove screws (16) and take off cover (9).
4. Remove two wire nuts connecting orange and gray leads from wiring assembly to leadwires from coil.
5. Screw wiring assembly strain relief out of cover (9). Remove heaters and temperature sensor from applicator body and thread through hole in cover.

6. Using 7/64 allen wrench, remove ground screw (8) and thread ground wires (green) through hole in cover.
7. Install new wiring assembly in reverse order.

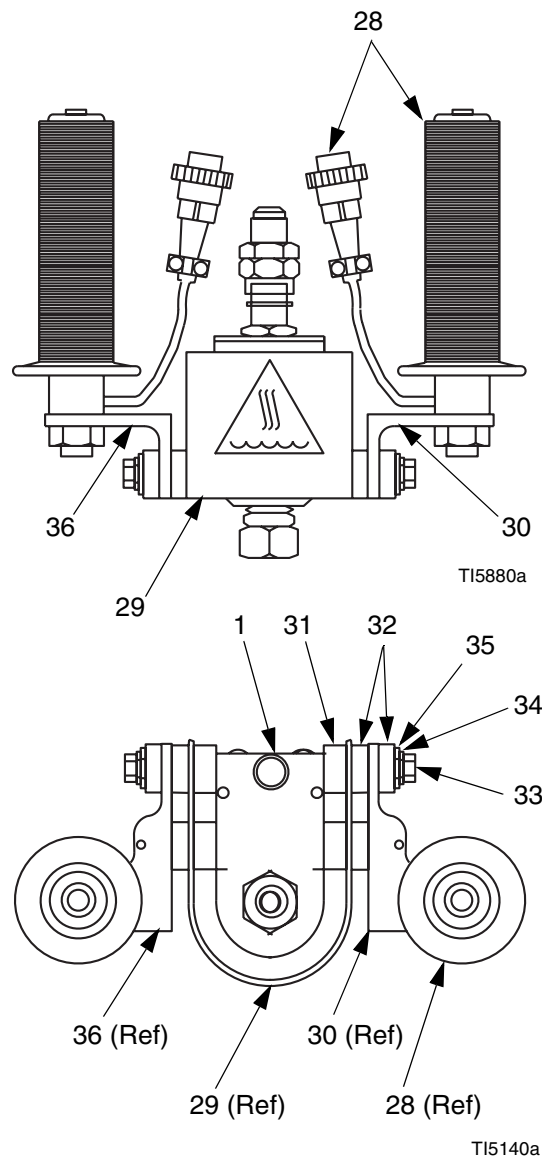

Fig. 5: VEA Applicator

Remove Swivel Assembly (VEA Units Only)



Swivel Assembly Kit 118167 is available to replace the swivel assembly. Parts included in the kit are marked with a symbol, for example (21†).

1. Follow **Pressure Relief Procedure**, page 12. Shut off tank power and unplug power cord. Remove hose from applicator. Allow parts to cool before disassembling.
2. See FIG. 6. Using two 13/16 in. wrenches, hold swivel nut (23) steady while unscrewing swivel end (27).



WARNING



Using a heat gun, heat swivel stem before disassembly. Wear gloves when handling heated parts.

3. Using pliers, hold swivel stem (25) and apply heat until swivel stem can be removed from needle stem (2). Swivel nut (23) will come off with stem.
4. Remove snap ring (22) to access press-fit ball (21). If ball does not release, use a sharp tool or knife to release it.
5. Install thrust washer (24†) and swivel stem (25†) in swivel nut (23†).
6. Apply Krytox[®] lubricant to o-ring grooves and o-rings (26†). Install o-rings on stem (25†).
7. Apply small amount of high temperature thread lock on threads of swivel stem and screw into needle stem (2) until groove is visible inside ball hole.
8. Seat ball (21†) in groove. Slip snap ring (22†) over ball to secure swivel stem (25†).
9. Apply Krytox[®] lubricant to cavity of swivel end (27†). Install swivel end, spinning it as it passes over the o-rings, to avoid damaging them. Tighten securely.

Remove Needle and Seat

 Spring (3), needle (4), o-ring (15), seat (5), and nut (6) are included in Stem Assembly Kits 118278 (EG Units) and 118168 (VEA Units).

1. Follow **Pressure Relief Procedure**, page 12. Shut off tank power and unplug power cord. Remove hose from applicator. Allow parts to cool before disassembling.
2. See FIG. 6. Remove nozzle nut (6).
3. Hold retainer nut (14) steady with a wrench while unscrewing seat (5) with a second wrench. Needle (4) and spring (3) will fall out when seat is removed.
4. Clean all parts and remove old glue and residue. Inspect o-ring (15) on seat (5) and replace if necessary. Apply Krytox[®] lubricant to o-ring (15).
5. Reassemble in reverse order.

Replace Needle Stem Assembly

 Stem Assembly Kits 118278 (EG Units) and 118168 (VEA Units) are available to replace the needle stem assembly. Parts included in the kits are marked with a symbol, for example (2*).

1. Follow **Pressure Relief Procedure**, page 12. Shut off tank power and unplug power cord. Remove hose from applicator. Allow parts to cool before disassembling.
2. Disconnect applicator wire connector from hose connector.
3. See **Remove Swivel Assembly (VEA Units Only)**, page 17.
4. See **Remove Needle and Seat**, above.
5. See FIG. 6. Hold hex of needle stem (2, on underside of applicator body) with a wrench or in a vise with soft jaws. Unscrew retainer nut (14).

6. Place applicator body (1) in vise. Using wrench on hex, unscrew needle stem (2) from applicator body.
7. Reassemble in reverse order.

 Make sure the coil housing (12), o-ring (20), and coil retainer (13) are properly assembled before tightening retainer nut (14).

Replace Coil

1. Follow **Pressure Relief Procedure**, page 12. Shut off tank power and unplug power cord. Remove hose from applicator. Allow parts to cool before disassembling.
2. Disconnect applicator wire connector from hose connector.
3. See **Remove Swivel Assembly (VEA Units Only)**, page 17.
4. See **Remove Needle and Seat**, at left.
5. See FIG. 6. Hold hex of needle stem (2, on underside of applicator body) with a wrench or in a vise with soft jaws. Unscrew retainer nut (14).
6. Lift off coil retainer (13), o-ring (20), and coil housing (12), to expose coil (7).
7. Using 3/32 allen wrench, remove screws (16) and take cover (9) off wire box.
8. Remove two wire nuts connecting orange and gray leads from wiring assembly (10) to leadwires from coil. Remove coil (7), pulling leadwires out of wire box.
9. Install new coil (7). Thread leadwires into wire box and connect to orange and gray leads from wiring assembly (10).
10. Reinstall coil housing (12), o-ring (20), and coil retainer (13). O-ring (20) is a vibration dampener to protect coil from damage.
11. Reassemble in reverse order.

⚠ Parts used on VEA units only.

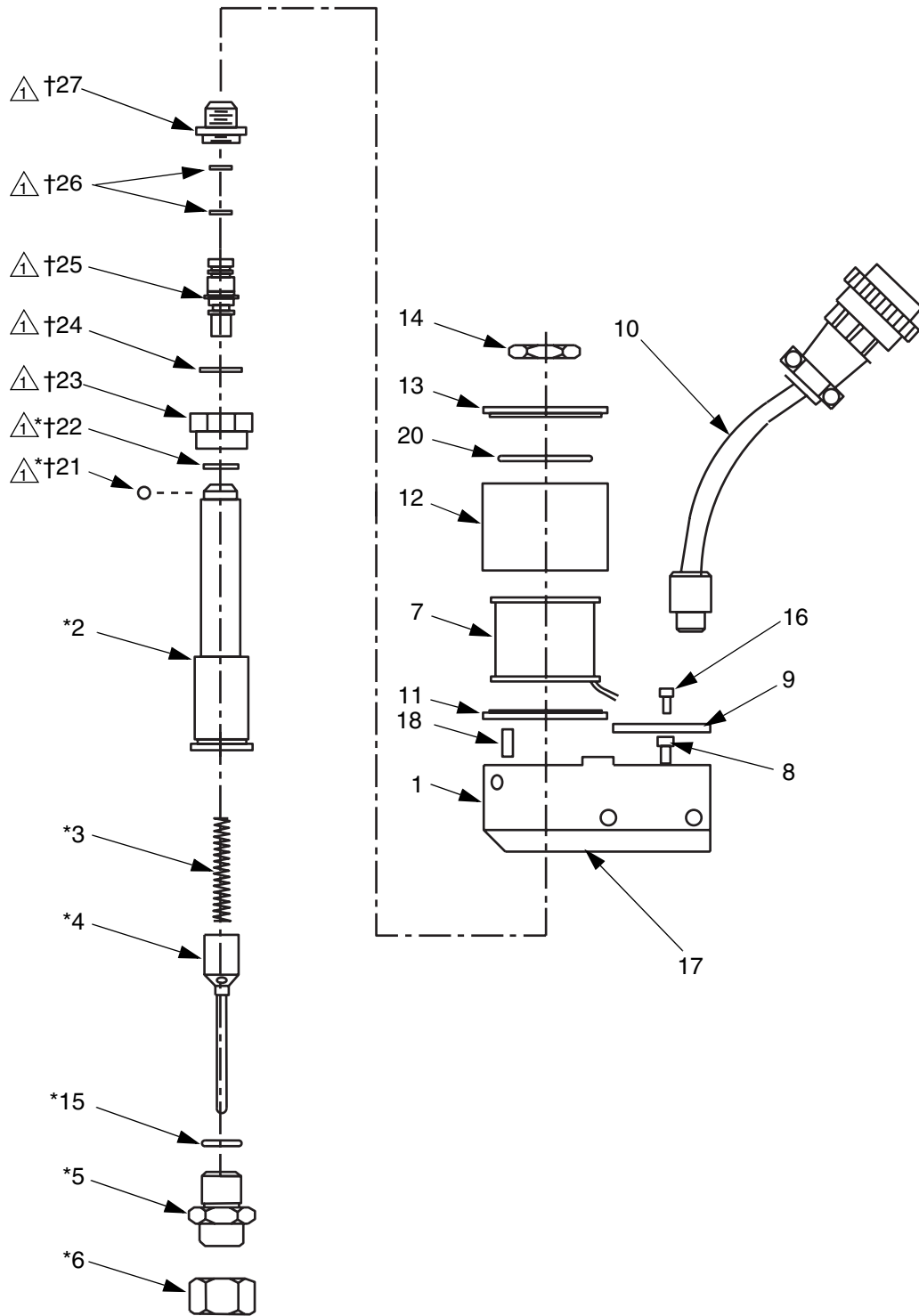

TI5879a

Fig. 6: VEA and EG Applicators (VEA Shown)

AG Applicator

Replace Needle/Piston and Packings



Repair Kit 118258 is available. Parts included in the kit are marked with a symbol, for example (11*)

1. Follow **Pressure Relief Procedure**, page 12. Shut off tank power and unplug power cord. Allow parts to cool before disassembling.
2. Make indexing marks on applicator body (1), bearing housing (3), and piston body (2) before disassembling, to ensure correct reassembly.
3. Using 5/32 allen wrench, remove capscrews (25). Carefully separate applicator body (1), piston body (2), and bearing housing (3), being careful not to bend needle (5). Seals (11) may come off on needle or may stay in housing (3). Inspect surface of needle, seals, and o-rings (14, 15) for wear or damage.
4. Pull needle (5) out of piston body (2), to remove piston and spring (9). Inspect piston o-ring (17).
5. Remove screw (22) and collar (8) from piston body (2). Inspect o-ring (12).
6. Remove nozzle nut (7) and seat (4). Inspect o-ring (13).
7. Apply Krytox[®] lubricant to o-rings (12, 13, 14, 15, 17) and seals (11) when reassembling.
8. Reassemble in reverse order.

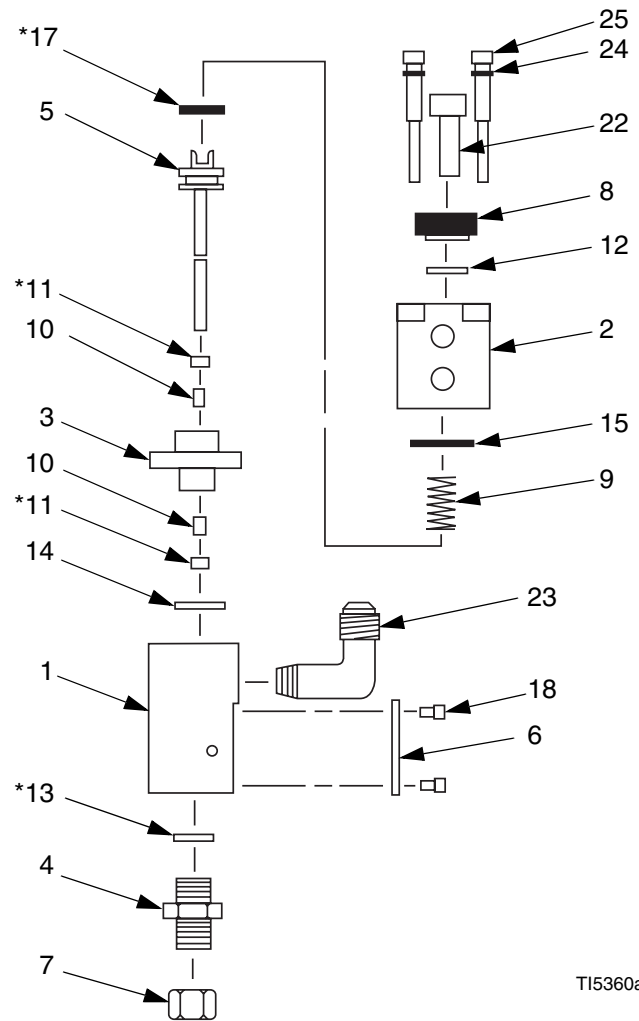

T15360a

FIG. 7: AG Applicator

Replace Heater/Sensor Wiring Assembly

 The wiring assembly (16) includes two heaters and one temperature sensor, which are not available separately.

1. Follow **Pressure Relief Procedure**, page 12. Shut off tank power and unplug power cord. Allow parts to cool before disassembling.
2. Disconnect applicator wire connector from hose connector.
3. See FIG. 7. Using 3/32 allen wrench, remove screws (18) and take off cover (6).
4. Slide wiring assembly strain relief out of body (1). Remove heaters and temperature sensor from applicator body.
5. See FIG. 8. Using 7/64 allen wrench, remove set screw (21) and ground wires (green).
6. Install new wiring assembly in reverse order.

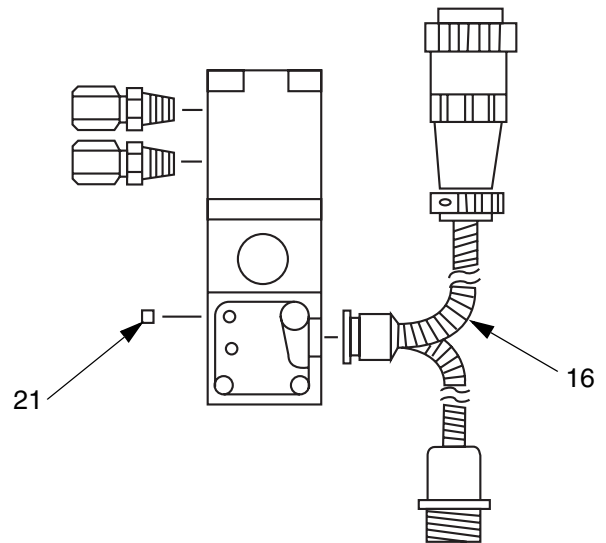

T15903a

FIG. 8: AG Wiring Assembly

Com-Pak Manifold

Replace Com-Pak Applicator

1. Follow **Pressure Relief Procedure**, page 12. Shut off tank power and unplug power cord. Allow parts to cool before disassembling.
2. Remove screws (13) and take Com-Pak applicator (2) off manifold (1). Remove o-rings (17).
3. Install o-rings (17) supplied with new applicator.
4. Install new Com-Pak applicator (2) on manifold (1) with screws (13).

Replace Heater/Sensor Wiring Assembly

 The wiring assembly (10) includes two heaters and one temperature sensor, which are not available separately.

1. Follow **Pressure Relief Procedure**, page 12. Shut off tank power and unplug power cord. Allow parts to cool before disassembling.

2. Disconnect applicator wire connector from hose connector.
3. Using 3/32 allen wrench, remove screws (12) and take off cover (3).
4. Using 1/16 allen wrench, remove set screw and ground wires (green). Remove heaters and temperature sensor from manifold. Slide wiring assembly strain relief out of manifold (1).
5. Install new wiring assembly in reverse order.

Adjust Applicator Actuation

1. With applicators under pressure, back off needle adjustment nut (N) on each applicator (2) until material flows from the nozzle.
2. Tighten nut (N) until material flow stops (if nut is not tight, adjuster will move as applicator is fired). Repeat for each applicator. All applicators will now start and stop simultaneously.

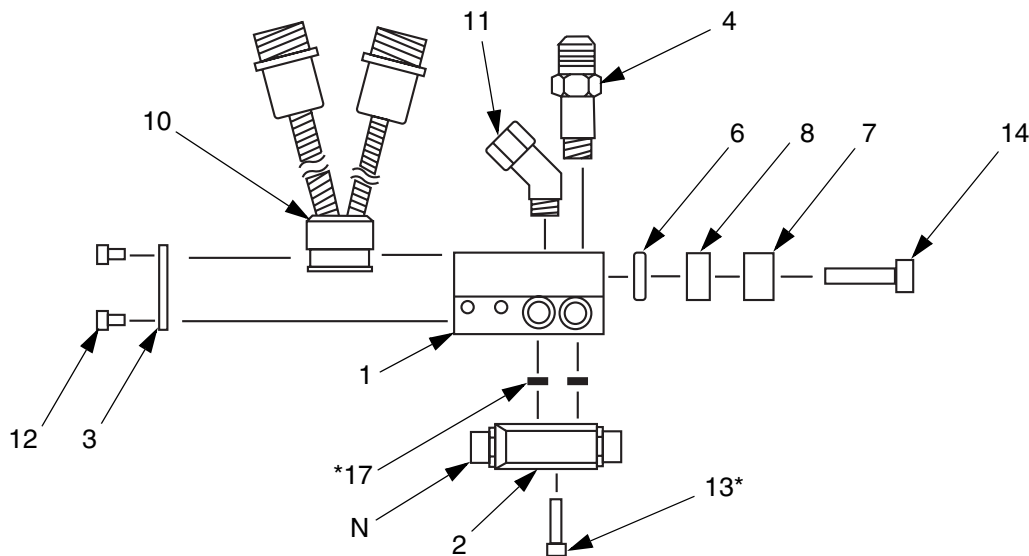

TI5359a

FIG. 9: Com-Pak Manifold

Parts

EG Head Assembly

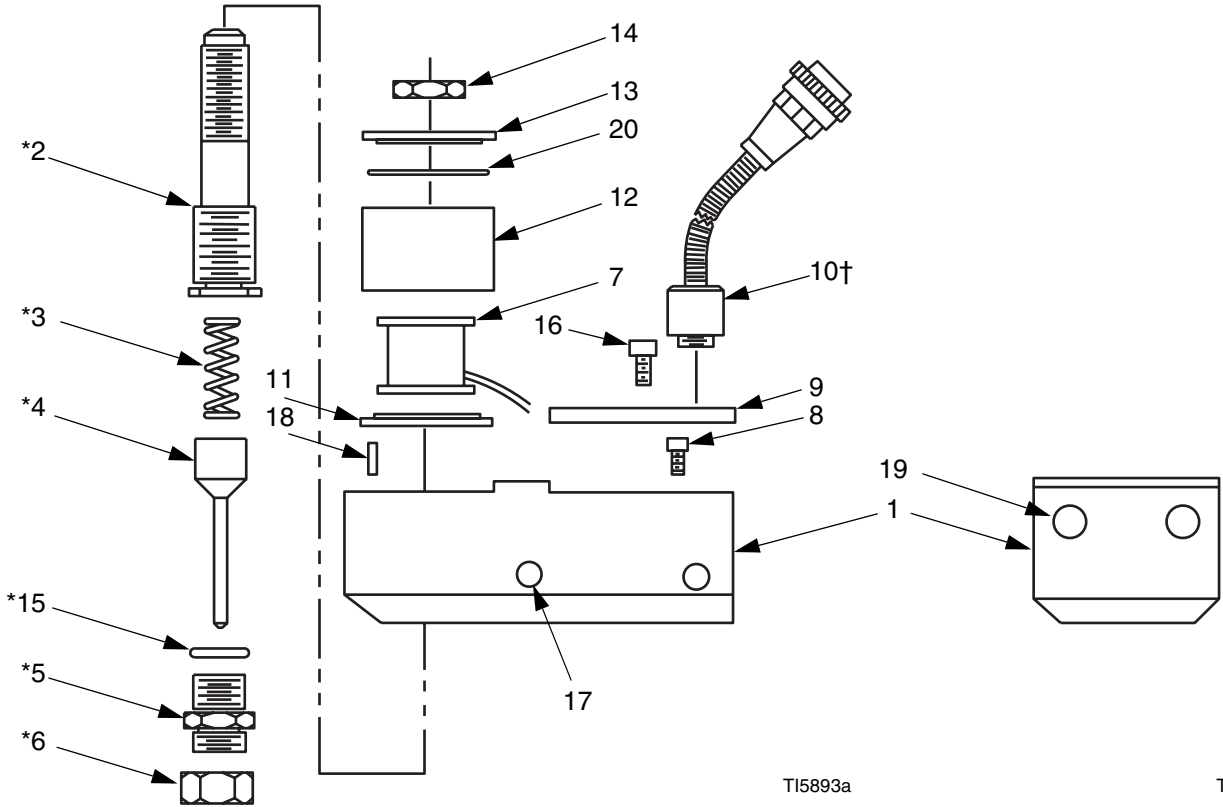

TI5893a

TI5894a

Ref. No.	Part No.	Description	Qty.	Ref. No.	Part No.	Description	Qty.
1		BODY	1	11		RETAINER, coil bottom	1
2*		STEM, needle	1	12		HOUSING, coil	1
3*		SPRING	1	13		RETAINER, coil top	1
4*		NEEDLE	1	14		NUT, retainer	1
5*		SEAT	1	15*		O-RING	1
6*		NUT, nozzle	1	16		SCREW, cap; 4-40 x 1/4 in.	2
7		COIL	1	17		HELICOIL INSERT; 1/4 x 20	4
	118229	115 Vac		18		PIN; 1/8 x 3/8 in.	1
	118230	230 Vac		19		PLUG, body	2
8		SCREW, cap; 6-32 x 1/4 in.	1	20		O-RING	1
9		COVER	1				
10		WIRING ASSY	1				
	118218	115 Vac					
	118219	230 Vac					

* Parts included in EG Stem Assembly Kit 118278 (purchase separately).

VEA Head Assembly

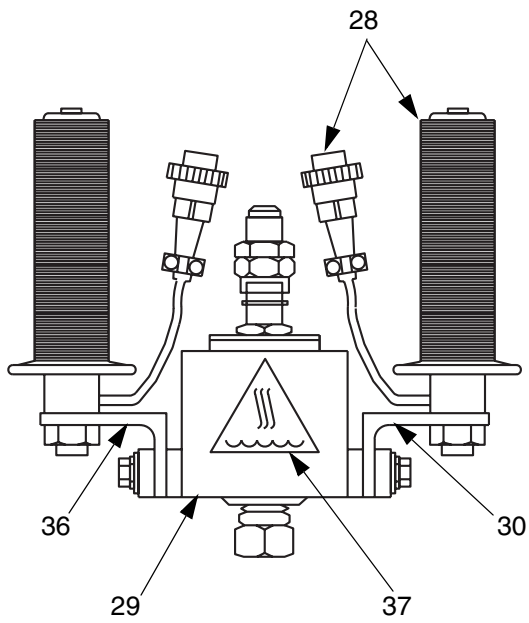

TI5880a

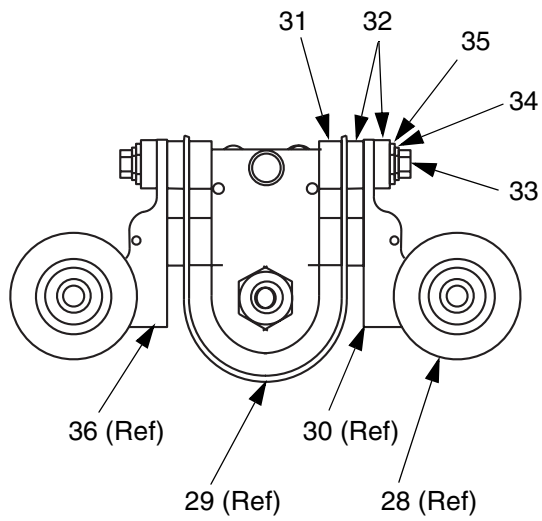

TI5140a

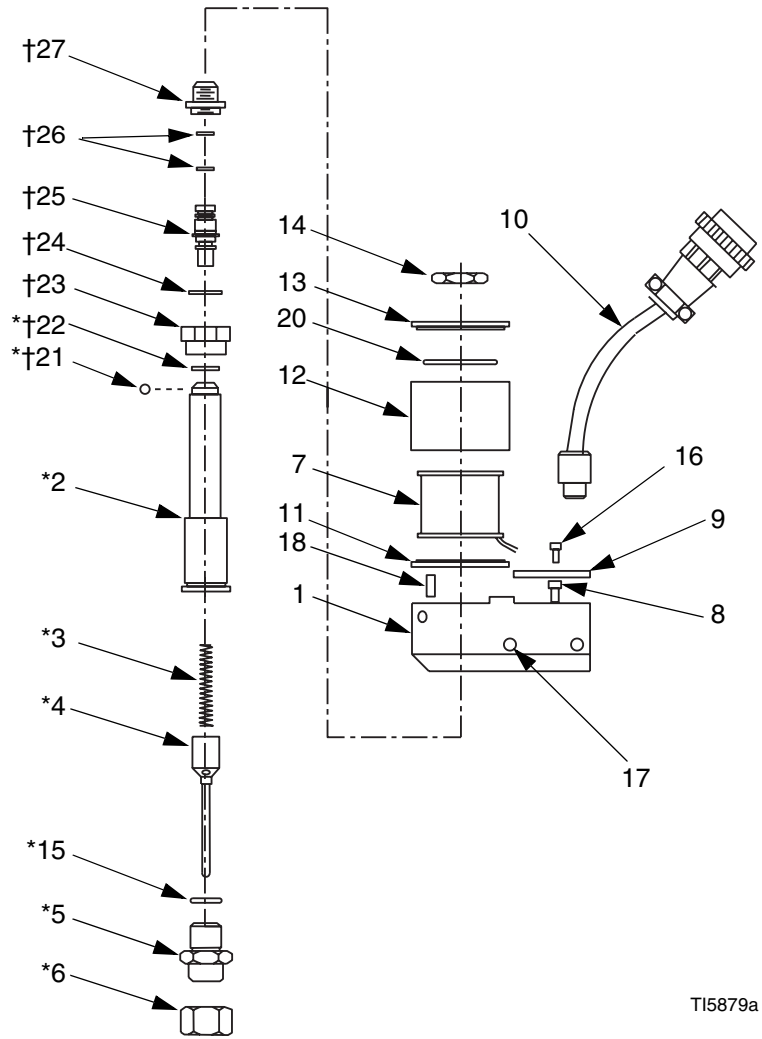

TI5879a

VEA Head Assembly

Ref. No.	Part No.	Description	Qty.	Ref. No.	Part No.	Description	Qty.
1		BODY	1	22*†		SNAP, ring	1
2*		STEM, needle	1	23†		NUT, swivel	1
3*		SPRING	1	24†		WASHER, thrust	1
4*		NEEDLE	1	25†		STEM, swivel	1
5*		SEAT	1	26†		O-RING	2
6*		NUT, nozzle	1	27†		END, swivel, JIC	1
7		COIL	1	28		HANDLES, control	2
	118228	24 Vdc		29		SHIELD	1
	118229	115 Vac		30		BRACKET, right	1
	118230	230 Vac		31		INSULATORS, thick	4
8		SCREW, cap; 6-32 x 1/4 in.	1	32		INSULATORS, thin	8
9		COVER	1	33		SCREWS, bracket	4
10		WIRING ASSY	1	34		WASHERS, lock	4
	118218	115 Vac		35		WASHERS, flat	4
	118219	230 Vac		36		BRACKET, left	1
11		RETAINER, coil bottom	1	37▲	119610	LABEL, warning	1
12		HOUSING, coil	1				
13		RETAINER, coil top	1				
14		NUT, retainer	1				
15*		O-RING	1				
16		SCREW, cap; 4-40 x 1/4 in.	2				
17		HELICOIL INSERT; 1/4 x 20	4				
18		PIN; 1/8 x 3/8 in.	1				
20		O-RING	1				
21*†		BALL	1				

* Parts included in VEA Stem Assembly Kit 118168 (purchase separately).

† Parts included in VEA Swivel Assembly Kit 118167 (purchase separately).

▲ Replacement Danger and Warning labels, tags, and cards are available at no cost.

Part No. 117961 Com-Pak 201, 120 Vac

Part No. 117962 Com-Pak 201, 230 Vac

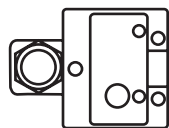

TI5896a

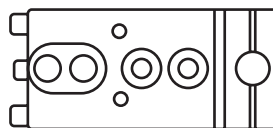

TI5897a

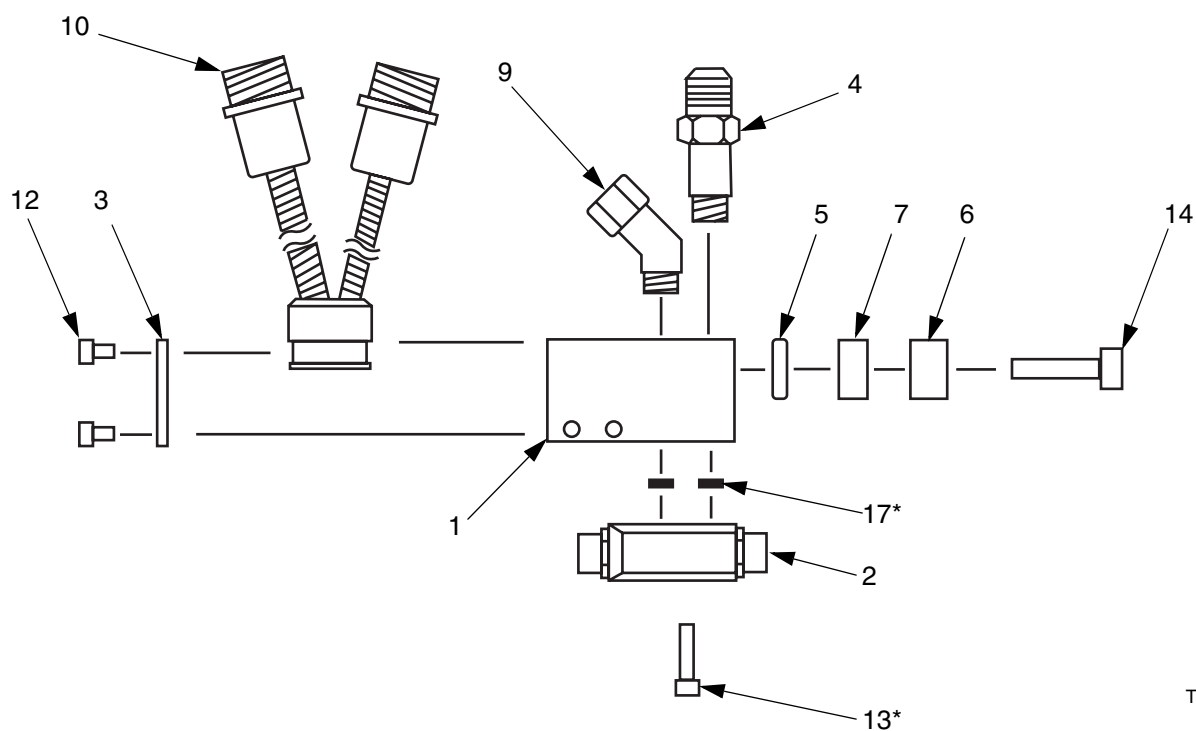

TI5356a

Ref. No.	Part No.	Description	Qty.	Ref. No.	Part No.	Description	Qty.
1		MANIFOLD, 201	1	9		FITTING; 1/4 in. compression x 1/8 npt	1
2	118068	HEAD, Com-Pak 200; includes items 13 and 17	1	10		WIRING ASSY	1
3		COVER, rear	1		118284	120 Vac	
4	118265	FITTING, JIC	1		118285	230 Vac	
5		INSULATION, clamp	1	12		SCREW, hex; 4-40 x 3/16 in.	3
6		CLAMP, mounting, A; 3/8 in.	1	13*		SCREW, hex; 6-32 x 5/8 in.	2
7		CLAMP, mounting, B; 3/8 in.	1	14		SCREW, hex; 10-32 x 3/4 in.	2
				17*		O-RING	2

* Parts included in item 2.

Part No. 117963 Com-Pak 202, 120 Vac

Part No. 117964 Com-Pak 202, 230 Vac

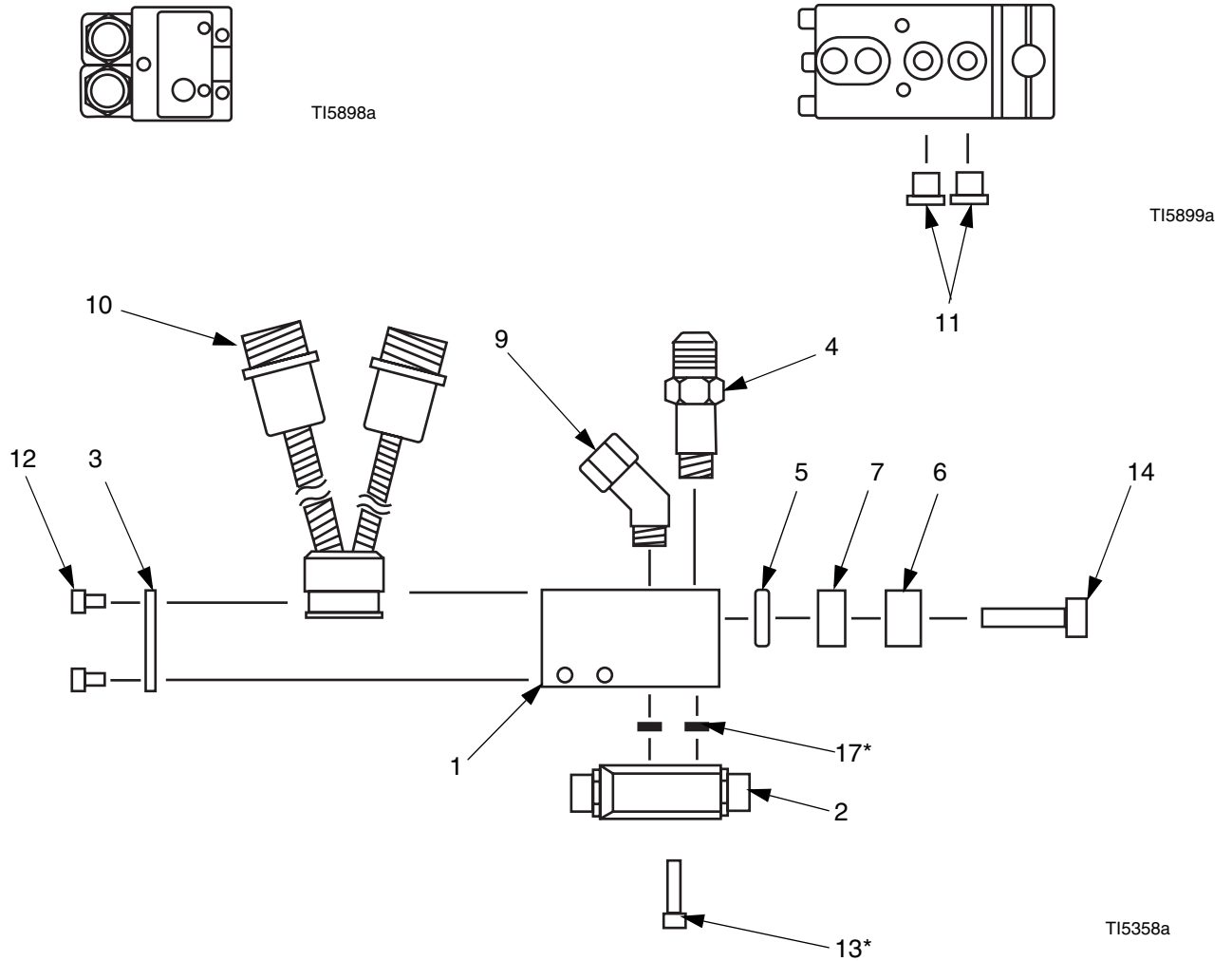

Ref. No.	Part No.	Description	Qty.	Ref. No.	Part No.	Description	Qty.
1		MANIFOLD, 202	1	10		WIRING ASSY	1
2	118068	HEAD, Com-Pak 200; includes items 13 and 17	2		118284	120 Vac	
3		COVER, rear	1		118285	230 Vac	
4	118265	FITTING, JIC	1	11		PLUG, cap	2
5		INSULATION, clamp	1	12		SCREW, hex; 4-40 x 3/16 in.	3
6		CLAMP, mounting, A; 3/8 in.	1	13*		SCREW, hex; 6-32 x 5/8 in.	4
7		CLAMP, mounting, B; 3/8 in.	1	14		SCREW, hex; 10-32 x 3/4 in.	2
9		FITTING; 1/4 in. compression x 1/8 npt	1	17*		O-RING	4

* Parts included in item 2.

Part No. 117965 Com-Pak 204, 115 Vac

Part No. 117966 Com-Pak 204, 230 Vac

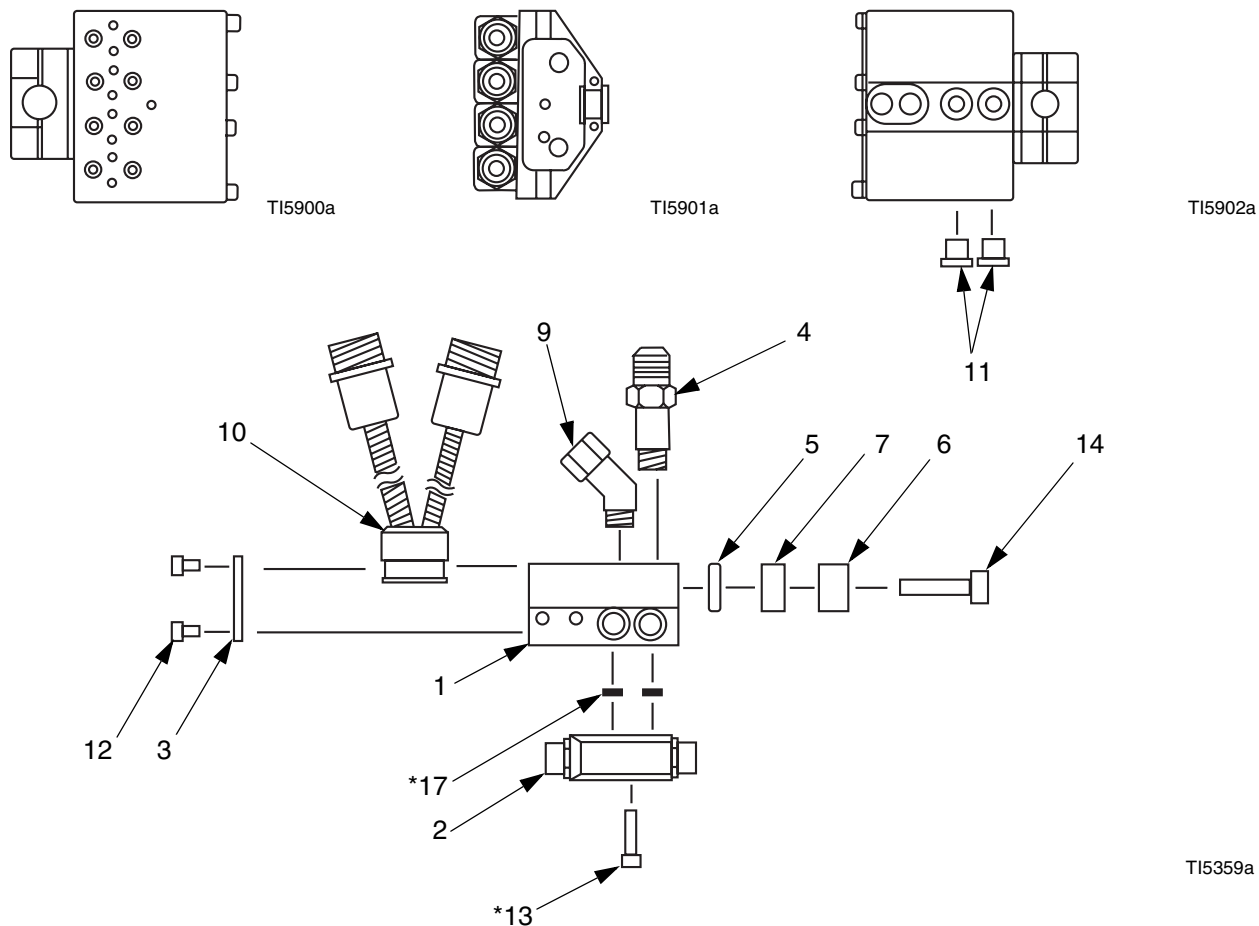

Ref. No.	Part No.	Description	Qty.	Ref. No.	Part No.	Description	Qty.
1		MANIFOLD, 204	1	10		WIRING ASSY	1
2	118068	HEAD, Com-Pak 200; includes items 13 and 17	4	118217		120 Vac	
3		COVER, rear	1	118287		230 Vac	
4	118265	FITTING, JIC	2	11		PLUG, cap	2
5		INSULATION, clamp	1	12		SCREW, hex; 4-40 x 3/16 in.	4
6		CLAMP, mounting, A; 3/8 in.	1	13*		SCREW, hex; 6-32 x 5/8 in.	8
7		CLAMP, mounting, B; 3/8 in.	1	14		SCREW, hex; 1/4-20 x 3/4 in.	2
9		FITTING; 1/4 in. compression x 1/8 npt	1	17*		O-RING	8

* Parts included in item 2.

Part No. 118288 AG Applicator, 115 Vac

Part No. 118289 AG Applicator, 230 Vac

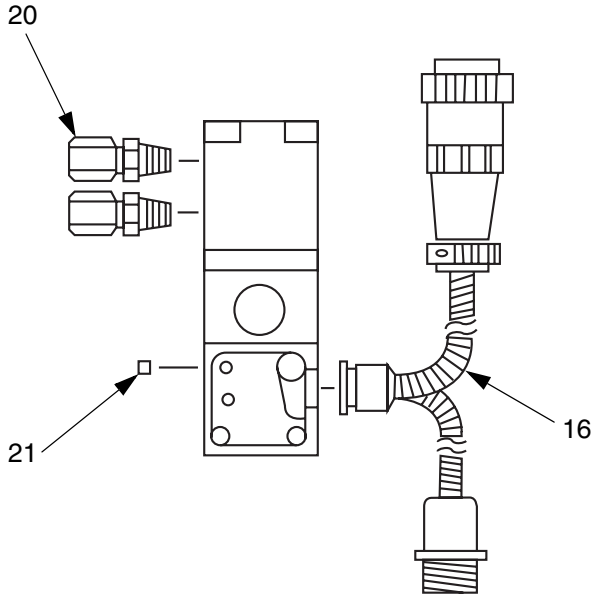

TI5903a

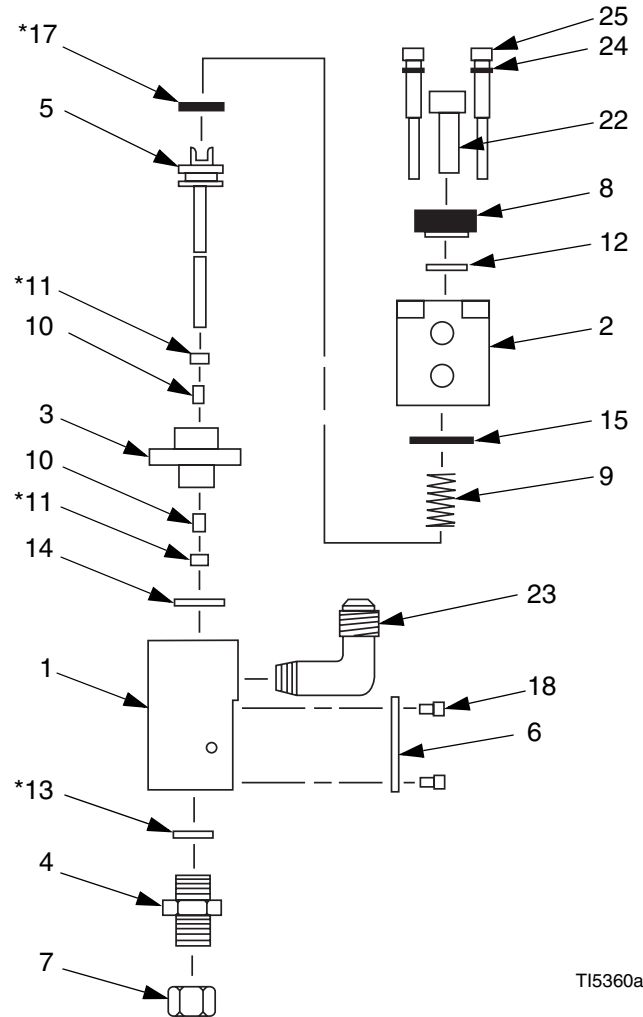

TI5360a

Ref. No.	Part No.	Description	Qty.
1		BODY, applicator	1
2		BODY, piston	1
3		HOUSING, bearing	1
4		SEAT	2
5		NEEDLE/PISTON ASSEMBLY	1
6		COVER, AG head	1
7		NUT, nozzle	1
8		COLLAR, AG lock	1
9		SPRING, return	1
10		BUSHING, shaft; 0.125	2
11*		SEAL, shaft; 0.125	2
12		O-RING	1
13*		O-RING	1
14		O-RING	1

Ref. No.	Part No.	Description	Qty.
15		O-RING	1
16		WIRING ASSY	1
	118282	120 Vac	
	118283	230 Vac	
17*		O-RING	1
18		SCREW, hex; 4-40 x 1/4 in.	4
20		FITTING; 1/8 npt	2
21		SCREW, set; 6-32 x 1/8 in.	1
22		SCREW, cap; 3/8 x 1 in.	1
23		FITTING, 90 JIC/npt	1
24		WASHER, lock	4
25		SCREW; 10-32 x 2 in.	4

* Parts included in Repair Kit 118258 (purchase separately).

Accessories

Extrusion Hoses

Hose Part No.	Length	Vac
117852	4 ft (1.2 m)	115
117853	6 ft (1.8 m)	115
117854	8 ft (2.4 m)	115
117855	10 ft (3 m)	115
117856	12 ft (3.6 m)	115
117857	16 ft (4.8 m)	115
117858	18 ft (5.4 m)	115
117859	24 ft (7.3 m)	115
117860	4 ft (1.2 m)	230
117861	6 ft (1.8 m)	230
117862	8 ft (2.4 m)	230
117863	10 ft (3 m)	230
117864	12 ft (3.6 m)	230
117865	16 ft (4.8 m)	230
117866	18 ft (5.4 m)	230
117867	20 ft (6 m)	230
117868	24 ft (7.3 m)	230

Swirl/Spray Hoses

Hose Part No.	Length	Vac
117872	4 ft (1.2 m)	115
117873	6 ft (1.8 m)	115
117874	8 ft (2.4 m)	115
117875	10 ft (3 m)	115
117876	12 ft (3.6 m)	115
117877	16 ft (4.8 m)	115
117878	18 ft (5.4 m)	115
117879	24 ft (7.3 m)	115
117880	4 ft (1.2 m)	230
117881	6 ft (1.8 m)	230
117882	8 ft (2.4 m)	230
117883	10 ft (3 m)	230
117884	12 ft (3.6 m)	230
117885	16 ft (4.8 m)	230
117886	18 ft (5.4 m)	230
117887	24 ft (7.3 m)	230

Swirl Assemblies

Part No.	Description	Orifice Size (in.)
118072	Swirl assembly (order nozzle separately)	n/a
117950	Swirl nozzle	.030
117951	Swirl nozzle	.045
117952	Swirl nozzle	.060
117953	Swirl nozzle	.080



FIG. 10: Swirl Assembly (shown with nozzle)

Spray Assemblies

Part No.	Description	Orifice Size (in.)
118073	Spray assembly (order nozzle separately)	n/a
117940	Spray nozzle	.020
117941	Spray nozzle	.030
117942	Spray nozzle	.040
117943	Spray nozzle	.050



FIG. 11: Spray Assembly (shown without nozzle)

T-Bar, Y-Bar, and Taper Conversion Bars

Part No.	Description
117967	T-bar for EG or AG applicator, 1 orifice each side
117968	T-bar for EG or AG applicator, 2 orifices each side
117969	T-bar for EG or AG applicator, 3 orifices each side
117973	Y-bar for EG or AG applicator, 1 orifice each side
117974	Y-bar for EG or AG applicator, 2 orifices each side
117975	Y-bar for EG or AG applicator, 3 orifices each side
117990	Taper conversion bar, 115 V, right side mount
117991	Taper conversion bar, 230 V, right side mount
117992	Taper conversion bar, 115 V, left side mount
117993	Taper conversion bar, 230 V, left side mount

Aim Nozzle Assemblies, for T-Bar, Y-Bar, or Taper Conversion Bar

Part No.	Description	Orifice Size (in.)
117980	Aim nozzle assembly. Includes o-rings.	.010
117981	Aim nozzle assembly. Includes o-rings.	.020
117982	Aim nozzle assembly. Includes o-rings.	.030
117983	Aim nozzle assembly. Includes o-rings.	.040
117976	Aim nozzle	.010
117977	Aim nozzle	.020
117978	Aim nozzle	.030
117979	Aim nozzle	.040
118074	Aim nozzle screws, package of 5	n/a
118075	Aim nozzle o-ring kit, package of 10	n/a
118076	Aim nozzle blanking screws, use in T-bar or Y bar to close off nozzle	n/a

Standard Extrusion Nozzles, 0.5 in. (13 mm)

Part No.	Orifice Size (in.)
117890	.020
117891	.030
117892	.040
117893	.050
117894	.060
117895	.070
117896	.080
117897	.090

Extrusion Nozzles, 3 in. (76 mm)

Part No.	Orifice Size (in.)
117914	.020
117915	.030
117916	.040
117917	.050
117918	.060
117919	.070
117920	.080
117921	.090

Extrusion Nozzles, 1 in. (25 mm)

Part No.	Orifice Size (in.)
117898	.020
117899	.030
117900	.040
117901	.050
117902	.060
117903	.070
117904	.080
117905	.090

Button Nozzles

Part No.	Orifice Size (in.)
117930	.012
117931	.015
117932	.025
117933	.030
117934	.040
117935	.050
117936	.060
117937	.070
117938	.080
117939	.090

Extrusion Nozzles, 2 in. (51 mm)

Part No.	Orifice Size (in.)
117906	.020
117907	.030
117908	.040
117909	.050
117910	.060
117911	.070
117912	.080
117913	.090

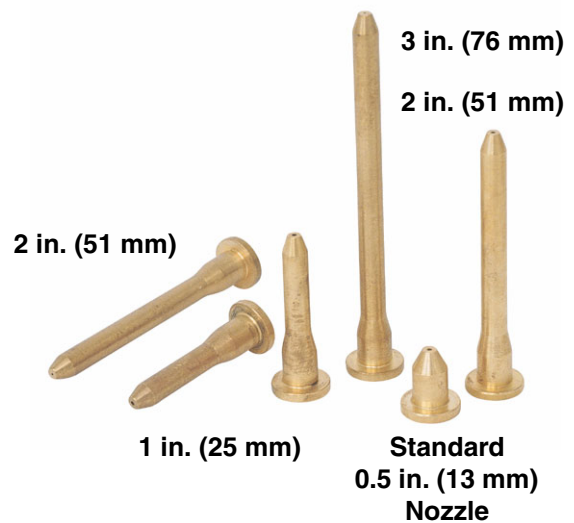

FIG. 12: Extrusion Nozzles

Com-Pak Extrusion Nozzles

Part No.	Description	Orifice Size (in.)
117834	Com-Pak extrusion nozzle	.010
117835	Com-Pak extrusion nozzle	.012
117836	Com-Pak extrusion nozzle	.015
117837	Com-Pak extrusion nozzle	.017
117838	Com-Pak extrusion nozzle	.020
117839	Com-Pak extrusion nozzle	.025
117840	Com-Pak extrusion nozzle	.030

Part No.	Description	Orifice Size (in.)
117841	Com-Pak extrusion nozzle	.040
117954	Replacement tip	.010
117955	Replacement tip	.012
117956	Replacement tip	.015
117957	Replacement tip	.017
117958	Replacement tip	.020
117959	Replacement tip	.025
117960	Replacement tip	.030

Schematics

EG and VEA Applicator

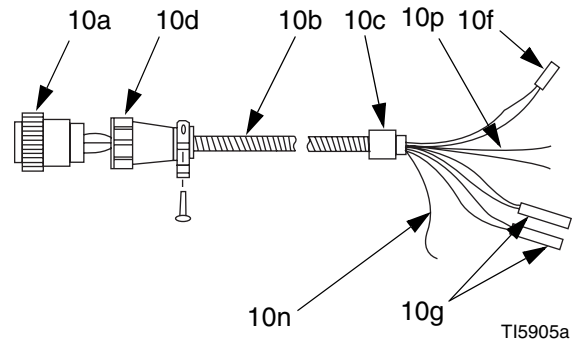
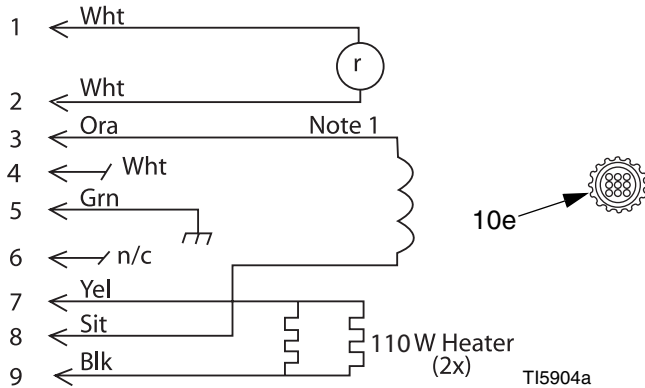

Ref. No.	Part No.	Description	Qty.	Ref. No.	Part No.	Description	Qty.
10a		CONNECTOR, 3 pin, male	1	10e		PIN, male	8
10b		HOUSING, armored wire	1	10f		SENSOR	1
10c		COLLAR, wire	1	10g		HEATER	2
10d		STRAIN RELIEF	1	10n		GROUND	1
				10p		COIL WIRE	1

AG Applicator

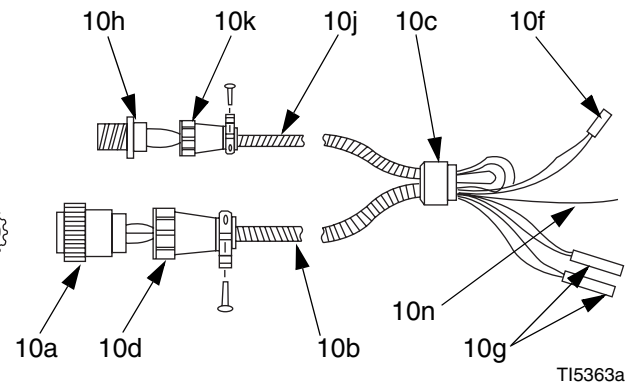
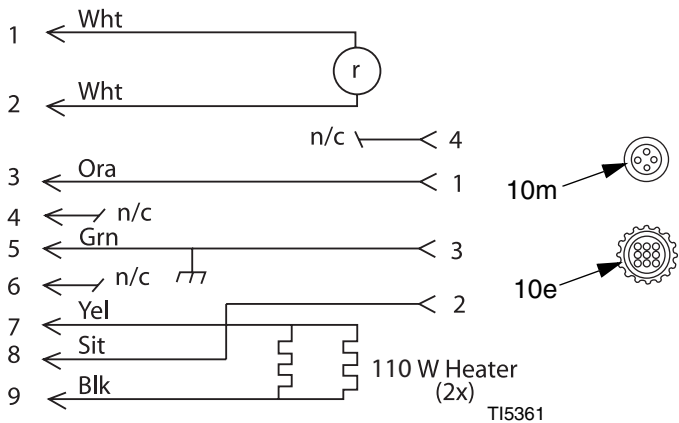

Ref. No.	Part No.	Description	Qty.	Ref. No.	Part No.	Description	Qty.
10a		CONNECTOR, 9 pin, male	1	10g		HEATER	2
10b		HOUSING, armored wire	1	10h		CONNECTOR, 4 pin, female	1
10c		COLLAR, wire	1	10j		HOUSING, armored wire	1
10d		STRAIN RELIEF	1	10k		STRAIN RELIEF	1
10e		PIN, male	8	10m		PIN, female	4
10f		SENSOR	1	10n		GROUND	1

Hose

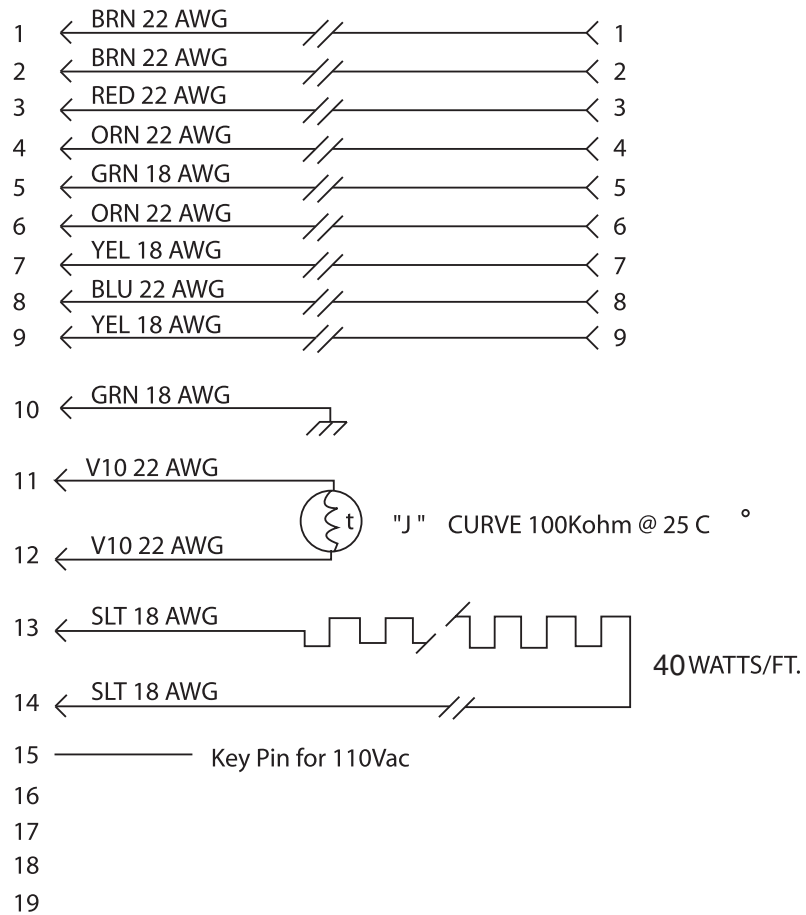

TI5906

Extrusion Hose

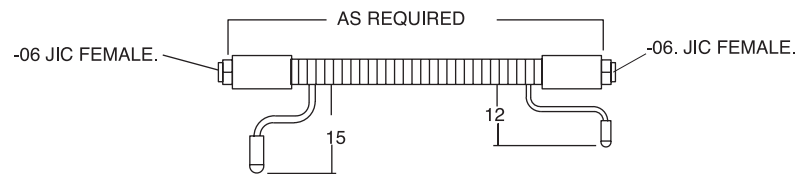

TI5907a

Air Spray/Swirl Hose

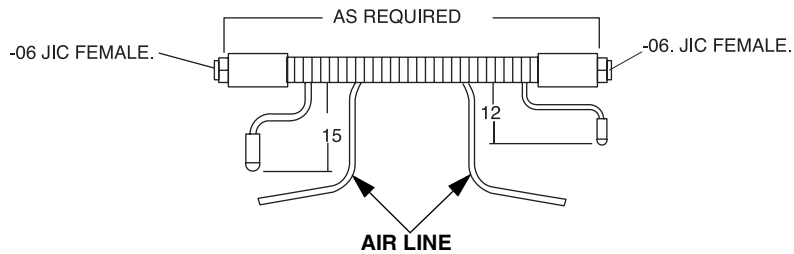

TI6285a

Com-Pak 201 and 202

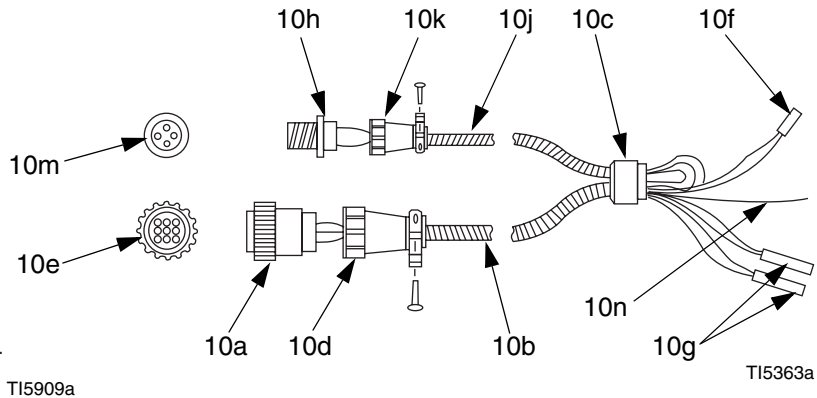
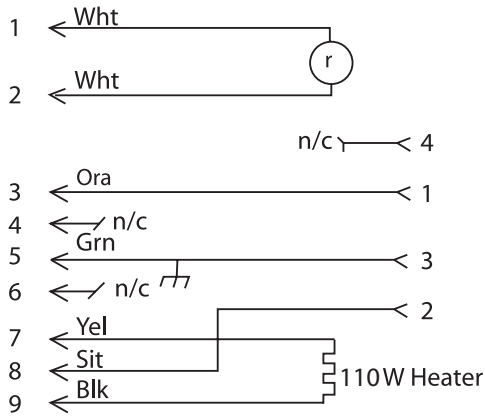

Ref. No.	Part No.	Description	Qty.	Ref. No.	Part No.	Description	Qty.
10a		CONNECTOR, 9 pin, male	1	10g		HEATER	2
10b		HOUSING, armored wire	1	10h		CONNECTOR, 4 pin, female	1
10c		COLLAR, wire	1	10j		HOUSING, armored wire	1
10d		STRAIN RELIEF	1	10k		STRAIN RELIEF	1
10e		PIN, male	8	10m		PIN, female	4
10f		SENSOR	1	10n		GROUND	1

Com-Pak 204

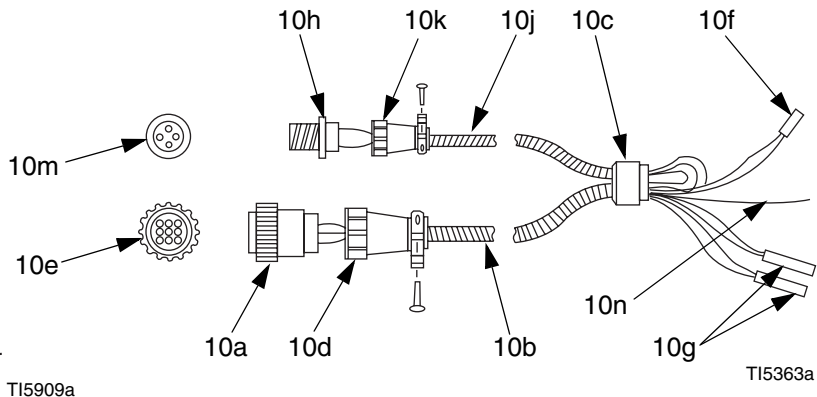
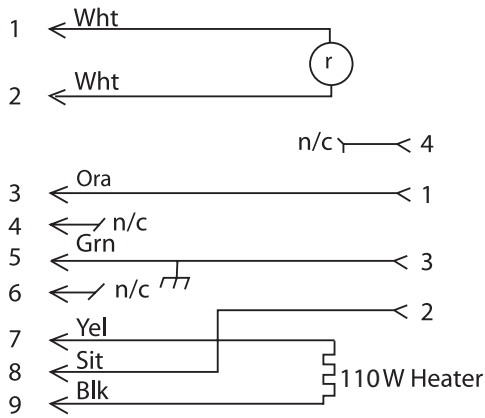

Ref. No.	Part No.	Description	Qty.	Ref. No.	Part No.	Description	Qty.
10a		CONNECTOR, 9 pin, male	1	10g		HEATER	2
10b		HOUSING, armored wire	1	10h		CONNECTOR, 4 pin, female	1
10c		COLLAR, wire	1	10j		HOUSING, armored wire	1
10d		STRAIN RELIEF	1	10k		STRAIN RELIEF	1
10e		PIN, male	8	10m		PIN, female	4
10f		SENSOR	1	10n		GROUND	1

Technical Data

Application temperature	up to 425°F (218°C)
Maximum fluid working pressure	3500 psi (23.3 MPa, 233 bar)*
Viscosity range	up to 20,000 centipoise*
Weight	<i>AG Applicator:</i> 2 lb (0.9 kg) <i>EG Applicator:</i> 2 lb (0.9 kg) <i>VEA Applicator:</i> 4 lb (1.8 kg) <i>Com-Pak Manifold:</i> 1 lb (0.45 kg) <i>Com-Pak Applicator:</i> less than 1 lb (0.45 kg)
Voltage	See pages 2 and 3.
Wattage	110 W
Wetted parts	Brass, aluminum, Viton®

* *EG and VEA Applicators are not recommended for high pressure applications or very viscous materials.*

All brand names or marks are used for identification purposes and are trademarks of their respective owners.

Graco Standard Warranty

Graco warrants all equipment referenced in this document which is manufactured by Graco and bearing its name to be free from defects in material and workmanship on the date of sale to the original purchaser for use. With the exception of any special, extended, or limited warranty published by Graco, Graco will, for a period of twelve months from the date of sale, repair or replace any part of the equipment determined by Graco to be defective. This warranty applies only when the equipment is installed, operated and maintained in accordance with Graco's written recommendations.

This warranty does not cover, and Graco shall not be liable for general wear and tear, or any malfunction, damage or wear caused by faulty installation, misapplication, abrasion, corrosion, inadequate or improper maintenance, negligence, accident, tampering, or substitution of non-Graco component parts. Nor shall Graco be liable for malfunction, damage or wear caused by the incompatibility of Graco equipment with structures, accessories, equipment or materials not supplied by Graco, or the improper design, manufacture, installation, operation or maintenance of structures, accessories, equipment or materials not supplied by Graco.

This warranty is conditioned upon the prepaid return of the equipment claimed to be defective to an authorized Graco distributor for verification of the claimed defect. If the claimed defect is verified, Graco will repair or replace free of charge any defective parts. The equipment will be returned to the original purchaser transportation prepaid. If inspection of the equipment does not disclose any defect in material or workmanship, repairs will be made at a reasonable charge, which charges may include the costs of parts, labor, and transportation.

THIS WARRANTY IS EXCLUSIVE, AND IS IN LIEU OF ANY OTHER WARRANTIES, EXPRESS OR IMPLIED, INCLUDING BUT NOT LIMITED TO WARRANTY OF MERCHANTABILITY OR WARRANTY OF FITNESS FOR A PARTICULAR PURPOSE.

Graco's sole obligation and buyer's sole remedy for any breach of warranty shall be as set forth above. The buyer agrees that no other remedy (including, but not limited to, incidental or consequential damages for lost profits, lost sales, injury to person or property, or any other incidental or consequential loss) shall be available. Any action for breach of warranty must be brought within two (2) years of the date of sale.

GRACO MAKES NO WARRANTY, AND DISCLAIMS ALL IMPLIED WARRANTIES OF MERCHANTABILITY AND FITNESS FOR A PARTICULAR PURPOSE, IN CONNECTION WITH ACCESSORIES, EQUIPMENT, MATERIALS OR COMPONENTS SOLD BUT NOT MANUFACTURED BY GRACO. These items sold, but not manufactured by Graco (such as electric motors, switches, hose, etc.), are subject to the warranty, if any, of their manufacturer. Graco will provide purchaser with reasonable assistance in making any claim for breach of these warranties.

In no event will Graco be liable for indirect, incidental, special or consequential damages resulting from Graco supplying equipment hereunder, or the furnishing, performance, or use of any products or other goods sold hereto, whether due to a breach of contract, breach of warranty, the negligence of Graco, or otherwise.

FOR GRACO CANADA CUSTOMERS

The Parties acknowledge that they have required that the present document, as well as all documents, notices and legal proceedings entered into, given or instituted pursuant hereto or relating directly or indirectly hereto, be drawn up in English. Les parties reconnaissent avoir convenu que la rédaction du présente document sera en Anglais, ainsi que tous documents, avis et procédures judiciaires exécutés, donnés ou intentés, à la suite de ou en rapport, directement ou indirectement, avec les procédures concernées.

Graco Information

TO PLACE AN ORDER, contact your Graco distributor or call to identify the nearest distributor.

Phone: 612-623-6921 **or Toll Free:** 1-800-328-0211 **Fax:** 612-378-3505

*All written and visual data contained in this document reflects the latest product information available at the time of publication.
Graco reserves the right to make changes at any time without notice.*

Graco Headquarters: Minneapolis
International Offices: Belgium, China, Japan, Korea

GRACO INC. P.O. BOX 1441 MINNEAPOLIS, MN 55440-1441

www.graco.com

Printed in USA 310803A

2/2005