

# Manual Hot Melt Applicators

310801B

*For dispensing non-explosive hot melt thermoplastic sealants and adhesives  
(see page 8).*



#### **Important Safety Instructions**

Read all warnings and instructions in this manual.  
Save these instructions.

See page 3 for model information, including  
maximum working pressure.



PROVEN QUALITY. LEADING TECHNOLOGY.

# Contents

<b>Models</b> .....	<b>3</b>	<b>Maintenance</b> .....	<b>11</b>
<b>Related Manuals</b> .....	<b>3</b>	Preventive Maintenance Schedule .....	11
<b>Manual Conventions</b> .....	<b>3</b>	Daily Maintenance .....	11
<b>Warnings</b> .....	<b>4</b>	Clean the Applicator .....	11
<b>Setup</b> .....	<b>6</b>	<b>Troubleshooting</b> .....	<b>12</b>
Grounding .....	6	<b>Repair</b> .....	<b>14</b>
Accessories .....	6	Replace Swivel .....	14
Flush Before Using Equipment .....	6	Applicator Body .....	14
Heated Hose Connection .....	6	Replace Needle .....	16
Air Spray and Swirl Applications .....	6	Replace Seat .....	16
<b>Operation</b> .....	<b>8</b>	Replace Heater, Temperature Sensor, and Wiring Assembly .....	17
Pressure Relief Procedure .....	8	Replace Motor Switch Trigger .....	17
Trigger Lock .....	8	<b>Parts</b> .....	<b>18</b>
Flushing .....	8	<b>Accessories</b> .....	<b>22</b>
Install Nozzle .....	9	<b>Schematics</b> .....	<b>26</b>
Spraying/Dispensing .....	9	<b>Technical Data</b> .....	<b>28</b>
Shutdown .....	9	<b>Dimensions</b> .....	<b>29</b>
		<b>Graco Standard Warranty</b> .....	<b>30</b>
		<b>Graco Information</b> .....	<b>30</b>

## Models

Part No., Series	Maximum Working Pressure psi (MPa, bar)	Description
117888, A	3500 (23.3, 233)	Manual Hot Melt Applicator, top feed, 115 Vac
117889, A	3500 (23.3, 233)	Manual Hot Melt Applicator, top feed, 230 Vac
118066, A	3500 (23.3, 233)	Manual Hot Melt Applicator, bottom feed, 115 Vac
118067, A	3500 (23.3, 233)	Manual Hot Melt Applicator, bottom feed, 230 Vac

## Related Manuals

Manual	Description
309831	THERM-O-FLOW® Hot Melt Tank T5
309832	THERM-O-FLOW® Hot Melt Tank T7
309833	THERM-O-FLOW® Hot Melt Tank T18

## Manual Conventions

**WARNING**



Hazard Symbol

**WARNING:** a potentially hazardous situation which, if not avoided, could result in death or serious injury.

Warnings in the instructions usually include a symbol indicating the hazard. Read the general **Warnings** section for additional safety information.





<b>CAUTION</b>
<b>CAUTION:</b> a potentially hazardous situation which, if not avoided, may result in property damage or destruction of equipment.







### Note

 Additional helpful information.

# Warnings

The following warnings include general safety information for this equipment. Further product specific warnings may be included in the text where applicable.

 <b>WARNING</b>	
	<p><b>ELECTRIC SHOCK HAZARD</b></p> <p>Improper grounding, setup, or usage of the system can cause electric shock.</p> <ul style="list-style-type: none"> <li>• Turn off and disconnect power cord before servicing equipment.</li> <li>• Use only grounded electrical outlets.</li> <li>• Use only 3-wire extension cords.</li> <li>• Ensure ground prongs are intact on sprayer and extension cords.</li> </ul>
	<p><b>BURN HAZARD</b></p> <p>Equipment surfaces and fluid that's heated can become very hot during operation. To avoid severe burns, do not touch hot fluid or equipment. Wait until equipment/fluid has cooled completely.</p>
	<p><b>SKIN INJECTION HAZARD</b></p> <p>High-pressure fluid from dispense valve, hose leaks, or ruptured components will pierce skin. This may look like just a cut, but it is a serious injury that can result in amputation. <b>Get immediate surgical treatment.</b></p> <ul style="list-style-type: none"> <li>• Do not point dispense valve at anyone or at any part of the body.</li> <li>• Do not put your hand over the end of the dispense nozzle.</li> <li>• Do not stop or deflect leaks with your hand, body, glove, or rag.</li> <li>• Follow <b>Pressure Relief Procedure</b> in this manual, when you stop spraying and before cleaning, checking, or servicing equipment.</li> </ul>
	<p><b>EQUIPMENT MISUSE HAZARD</b></p> <p>Misuse can cause death or serious injury.</p> <ul style="list-style-type: none"> <li>• Do not exceed the maximum working pressure or temperature rating of the lowest rated system component. See <b>Technical Data</b> in all equipment manuals.</li> <li>• Use fluids and solvents that are compatible with equipment wetted parts. See <b>Technical Data</b> in all equipment manuals. Read fluid and solvent manufacturer's warnings.</li> <li>• Check equipment daily. Repair or replace worn or damaged parts immediately.</li> <li>• Do not alter or modify equipment.</li> <li>• For professional use only.</li> <li>• Use equipment only for its intended purpose. Call your Graco distributor for information.</li> <li>• Route hoses and cables away from traffic areas, sharp edges, moving parts, and hot surfaces.</li> <li>• Do not use hoses to pull equipment.</li> <li>• Comply with all applicable safety regulations.</li> </ul>

 <b>WARNING</b>	
	<p><b>TOXIC FLUID OR FUMES HAZARD</b></p> <p>Toxic fluids or fumes can cause serious injury or death if splashed in the eyes or on skin, inhaled, or swallowed.</p> <ul style="list-style-type: none"> <li>• Read MSDS's to know the specific hazards of the fluids you are using.</li> <li>• Store hazardous fluid in approved containers, and dispose of it according to applicable guidelines.</li> </ul>
	<p><b>PRESSURIZED ALUMINUM PARTS HAZARD</b></p> <p>Do not use 1,1,1-trichloroethane, methylene chloride, other halogenated hydrocarbon solvents or fluids containing such solvents in pressurized aluminum equipment. Such use can cause serious chemical reaction and equipment rupture, and result in death, serious injury, and property damage.</p>
  	<p><b>PERSONAL PROTECTIVE EQUIPMENT</b></p> <p>You must wear appropriate protective equipment when operating, servicing, or when in the operating area of the equipment to help protect you from serious injury, including eye injury, inhalation of toxic fumes, burns, and hearing loss. This equipment includes but is not limited to:</p> <ul style="list-style-type: none"> <li>• Protective eyewear</li> <li>• Clothing and respirator as recommended by the fluid and solvent manufacturer</li> <li>• Gloves</li> <li>• Hearing protection</li> </ul>

# Setup

## Grounding

WARNING



Your system must be grounded. Read warnings, page 4.

Ground the applicator through connection to a properly grounded fluid hose and hot melt tank. See your hot melt tank manual for further instructions.

## Accessories

Install the following accessories in the order shown in FIG. 1, using adapters as necessary.

- **Heated Hose (F):** allows adhesive to flow from the tank to the applicator while maintaining the set temperature.
  - Extrusion Hose: for extrusion application. See page 22.
  - Spray/Swirl Hose: includes air line (L) in the hose jacket. See page 22.
- **Air Saver Control Unit (H):** for spray or swirl pattern applications. Adjusts and regulates air to the applicator. Order 118041 for 115 Vac systems or 118042 for 230 Vac systems.

## Flush Before Using Equipment

The equipment was tested with hot melt, which is left in the fluid passages to protect parts. To avoid contaminating your fluid with this hot melt, purge the equipment with new hot melt, 118090 Purge Compound, or a compatible non-flammable solvent before using the equipment. See **Flushing**, page 8.

## Heated Hose Connection

See FIG. 1. Connect the heated hose (F) to the applicator fluid inlet. Tighten securely with wrenches, one on the applicator inlet and one on the hose.

Install the swivel inlet insulation and shield (N) over the applicator swivel inlet, and secure with two screws.

Align the keys of the heated hose cable connector (E) to the applicator's wiring assembly (D) connector, and securely screw the connectors together.

## Air Spray and Swirl Applications

See FIG. 1. Air spray and swirl applications require installation of the Air Saver Control (H). Order 118041 for 115 Vac systems or 118042 for 230 Vac systems. Also order the air spray or swirl adapter (M) and the desired nozzle. See the charts on page 22 for available nozzles.

Remove the nozzle nut (25) and nozzle (12), and screw the spray or swirl adapter (M) onto the applicator (A). Tighten securely. Do not install the nozzle yet.

Bring an air supply line (K) to the air inlet at the back of the air saver control (H). Do not turn the air on yet.

Connect the air line (L) from the heated hose (F) to the air output on the front of the air saver control (H). Connect the tube from the air spray or swirl adapter (M) to the other end of the hose air line.

Connect the electrical cable (J) from the air saver control (H) to the auxiliary receptacle on the hot melt tank (G). To operate the air saver control, you must set the auxiliary control; see the hot melt tank manual.

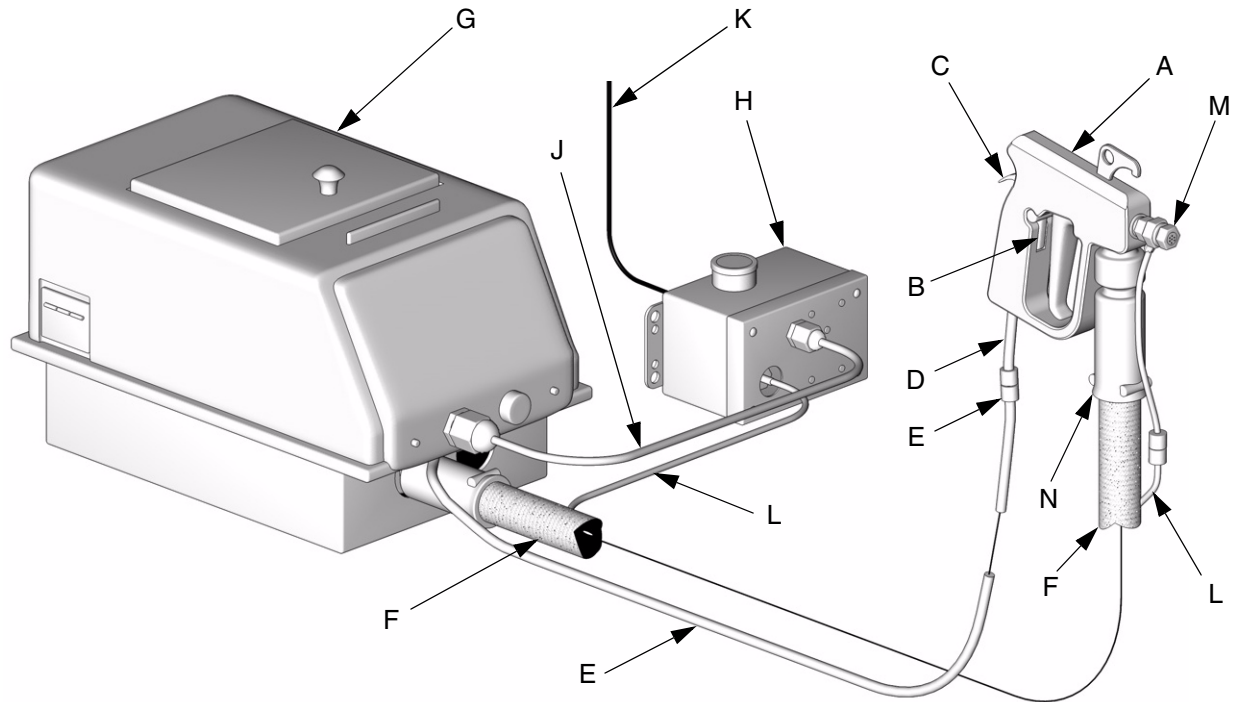

TI6283a

**FIG. 1: Typical Installation of Bottom Feed Manual Applicator, shown with optional swirl assembly**

**Key:**

- |   |  |   |   |
|---|--|---|---|
| A | Manual Applicator, bottom feed, shown with optional swirl assembly installed | H | Air Saver Control (required for airspray and swirl applications)          |
| B | Trigger Lock   | J | Air Saver Control Electrical Connection                                   |
| C | Motor Switch Trigger   | K | Air Saver Control Air Supply Line   |
| D | Applicator Wiring Assembly   | L | Applicator Air Supply Line (required for airspray and swirl applications) |
| E | Hose Electrical Connector  | M | Optional Swirl Assembly   |
| F | Heated Hose  | N | Swivel Inlet Insulation and Shield  |
| G | Hot Melt Tank (Model T7 shown)   |   |   |

# Operation

## Pressure Relief Procedure

 **WARNING**

Follow **Pressure Relief Procedure** when you stop spraying and before cleaning, checking, servicing, or transporting equipment. Read warnings, page 4.

1. Engage trigger lock (B, FIG. 1).
2. Shut off pump motor.
3. Disengage trigger lock (B).
4. Actuate applicator, dispensing material into an empty pail, until material stops dispensing through the applicator.
5. Engage trigger lock (B).
6. If you suspect the nozzle or hose is clogged or that pressure has not been fully relieved after following the steps above, **VERY SLOWLY** loosen nozzle retaining nut or hose end coupling to relieve pressure gradually, then loosen completely. Clear hose or nozzle obstruction.

## Trigger Lock

Always engage the trigger lock (B) when you stop spraying to prevent the applicator from being triggered accidentally by hand or if dropped or bumped.

## Flushing

 **WARNING**



This equipment is designed for use with standard adhesive and sealant such as EVA's, butyls, and polyolefins with flash points above 450°F (232°C). Not recommended for water curable or solvent based adhesive. Do not use flammable material or material not compatible with the specifications of this equipment. Failure to follow this instruction can cause injury to operators and damage to equipment.



- Flush before changing materials.
  - Flush at the lowest pressure possible. Check connectors for leaks and tighten as necessary.
  - Flush with 118090 Purge Compound.
1. Follow **Pressure Relief Procedure**, page 8.
  2. Remove nozzle and seat, and clean with purge compound.
  3. Flush system, following **Flushing** procedure given in hot melt tank manual. Trigger the applicator until clean compound dispenses.
  4. Follow **Pressure Relief Procedure**, page 8.
  5. Remove applicator from hose. See **Clean the Applicator**, page 11.



## Install Nozzle

1. Follow **Pressure Relief Procedure**, page 8.
2. Install the desired nozzle in the applicator. See pages 22-23 for available nozzles.

For swirl applications, insert swirl nozzle as shown to avoid equipment damage.

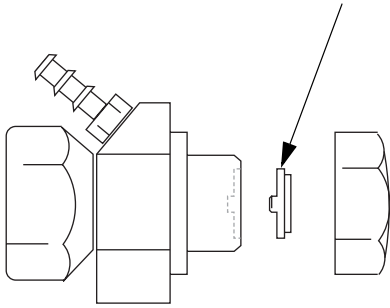

T16286a

## Spraying/Dispensing

### **WARNING**



Do not point the applicator toward anyone when the system is powered. Pressures can develop within the hot melt system which can project hot fluid significant distances.

1. Set the applicator temperature. See your hot melt tank manual.

### **CAUTION**

Triggering the applicator before the adhesive is at operating temperature can damage the needle. This damage is not covered under warranty.

2. Start the hot melt tank and bring the entire system up to operating temperature. See your hot melt tank manual.
3. Use the motor switch trigger (C) to control pump motor operation from the applicator. This prevents unnecessary wear on the motor, pump, and adhesive.

## Shutdown

Follow **Pressure Relief Procedure**, page 8.



A series of horizontal lines for writing or calculation, starting from the top line and extending down to the bottom line.

# Maintenance

## Preventive Maintenance Schedule

Establish a preventive maintenance schedule, based on the equipment's repair history.

## Daily Maintenance

Before using the applicator, perform the following checks.

1. Wipe off all excess adhesive from all surfaces with 118090 Purge Compound.
2. Check the hoses, applicator heads, and nozzles for wear and ensure integrity of all electrical connections.
3. Verify the hose is being properly supported so it is not over-stressed during use. The minimum bend diameter is 16 in. (41 cm) when hot.
4. Look for leaks under the melt unit and at all mechanical connections.
5. Tighten all threaded connections before each use.

## Clean the Applicator

### **WARNING**



Applicator cannot be cleaned if material has cooled. Using a heat gun, heat the parts before disassembling. Wear gloves when handling heated parts.

1. Follow **Pressure Relief Procedure**, page 8.
2. Remove nozzle and seat, and clean in purge compound.
3. Open the applicator body, page 14.
4. Remove the needle assembly, page 16. Clean the needle assembly and fluid manifold (9).
5. Reassemble in reverse order.

# Troubleshooting

Problem	Cause	Solution
Applicator head not heating.	Applicator head not turned on at hot melt tank panel.	Turn on.
	Applicator not plugged in.	Plug applicator cable into hose connector.
	Incorrect voltage.	Check that power supply is correct voltage for equipment.
	Applicator temperature is too low.	Increase applicator temperature setting; see tank manual.
	Tank temperature too low.	Increase tank temperature setting; see tank manual.
	Improper mating of pin connection.	Inspect pins and remove strain relief. Inspect wiring for damage.
	Bad connection at hot melt tank circuit boards.	Inspect circuit board connections; see tank manual.
	Bad hot melt tank fuses.	Check fuses for continuity.
	Bad hose heater wire.	Check for continuity between pins 7 and 9 of 9 pin connector.
	Temperature sensor is open or not functioning correctly (open sensor light is lit on tank).	Reading should be approximately 100 K ohms between pins 1 and 2 of 9 pin connector. Replace wiring assembly, page 17.
	Applicator heater is damaged.	Replace wiring assembly, page 17.
Low or no flow of material from unit.	No power to tank.	Plug in tank. Turn on/off switch ON.
	Front panel settings not properly set.	See tank manual.
	Not enough material in tank.	Add material. See tank manual.
	Viscosity of material too high; tank temperature too low.	Increase temperature settings. Reference material manufacturer's instruction. Adjust controls, see tank manual.
		Increase orifice size.
	Applicator nozzle plugged.	Clean nozzle or replace.
	Hose is kinked or bent.	Check for kinks in hose, replace if damaged. See tank manual.
	Pump damaged.	Replace pump, see tank manual.
	Motor switch trigger not functioning.	Check position of spring (32). Replace motor switch trigger, page 17.
	Temperature sensor is open or not functioning correctly (open sensor light is lit on tank).	Reading should be approximately 100 K ohms between pins 1 and 2 of 9 pin connector. Replace wiring assembly, page 17.

Problem	Cause	Solution
Material leaks from nozzle.	Damaged or dirty needle or seat.	Clean or replace needle assembly and/or seat, page 16.
Material leaks from hose connection.	Threads at hose connection not seated properly.	Tighten connection. Clean threads by heating or using purging compound 118090.
	Damaged swivel o-rings.	Replace swivel, page 14.

# Repair

## Replace Swivel

 Swivel Repair Kit 118162 is available. The kit includes the swivel end (27) and o-rings (35).

 Swivel Insulation Kit 118163 is available. The kit includes the insulation (30), shields (28), and screws (29).

1. Follow **Pressure Relief Procedure**, page 8. Shut off tank power and unplug power cord. Remove hose from applicator. Allow parts to cool before disassembling.
2. Remove screws (29), shields (28), and insulation (30).

### **WARNING**



Swivel end (27) cannot be removed if material has cooled. Using a heat gun, heat parts before disassembly. Wear gloves when handling heated parts.

3. See FIG. 2. Using two 13/16 wrenches, remove swivel end (27) from fluid manifold (9). Remove two o-rings (35) from fluid manifold stem.
4. Clean all parts and remove old glue and residue.
5. Apply Krytox<sup>®</sup> lubricant to o-ring grooves, cavity of swivel end (27), and o-rings (35). Install o-rings on stem.

6. Install swivel end (27), spinning it as it passes over the o-rings, to avoid damaging them. Tighten securely.
7. Reinstall insulation (30), shields (28), and two screws (29).

## Applicator Body

### Disassemble Applicator Body

1. Follow **Pressure Relief Procedure**, page 8. Shut off tank power and unplug power cord. Remove hose from applicator. Allow parts to cool before disassembling.
2. See FIG. 2. Fully loosen screws (7). Holding halves of applicator body (1) together, flip body over so screw holes are on bottom, then pull halves apart.
3. Note orientation of trigger lock (3) and motor switch trigger (8).

### Reassemble Applicator Body

1. See FIG. 2. Check that all parts are correctly positioned in one half of applicator body (1). Verify correct orientation of motor switch trigger (8) and trigger lock (3).
2. Install second half of applicator body (1). Insert screw (7) through motor trigger (8) first, and check spring tension of trigger.
3. Install remaining screws (7) and tighten securely. Verify that motor trigger (8) moves freely. If motor trigger sticks, back its screw (7) out about 1/8 turn until trigger moves freely.

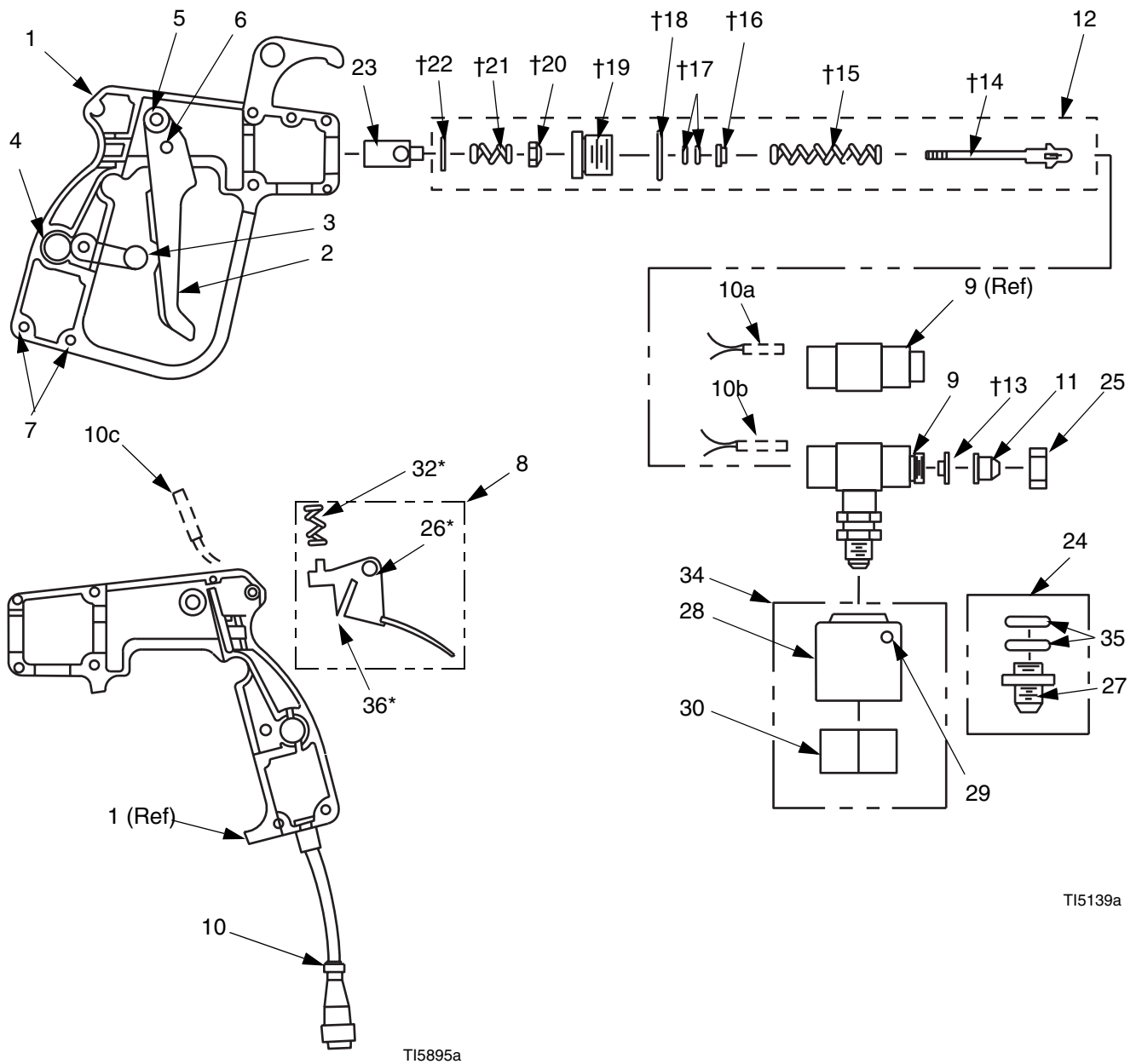



FIG. 2: Applicator Repair

## Replace Needle

 Rebuild Kit 118164 is available to replace the needle assembly. The kit includes a preassembled needle and seat. Parts included in the kit are marked with a symbol, for example (13†).

1. Follow **Pressure Relief Procedure**, page 8. Shut off tank power and unplug power cord. Remove hose from applicator. Allow parts to cool before disassembling.
2. See FIG. 2. Remove nozzle nut (25), nozzle (11), and seat (13).
3. **Disassemble Applicator Body**, page 14.

### WARNING



Needle cannot be removed if material has cooled. Using a heat gun, heat parts before disassembly. Wear gloves when handling heated parts.

4. Using a 3/4 in. wrench, unscrew the seal housing (19) from the fluid manifold (9), and remove the needle assembly (12) from the fluid manifold.
5. Using 3/8 in. wrench on retainer nut (20), unscrew needle assembly from rocker handle (23) of trigger (2).

6. If you are not installing a new needle assembly, clean all parts and remove old glue and residue.
7. Apply a small amount of Krytox<sup>®</sup> lubricant to new needle (14) and spring (15). Install the new needle assembly in the reverse order.
8. **Reassemble Applicator Body**, page 14.

## Replace Seat

 Seat (13) is included in Needle Rebuild Kit 118164.

### WARNING



Seat cannot be removed if material has cooled. Using a heat gun, heat parts before disassembly. Wear gloves when handling heated parts.

1. Follow **Pressure Relief Procedure**, page 8. Shut off tank power and unplug power cord. Remove hose from applicator. Allow parts to cool before disassembling.
2. See FIG. 2. Remove nozzle nut (25), nozzle (11), and seat (13).
3. Clean all parts and remove old glue and residue.
4. Replace seat (13). Reassemble.



## Replace Heater, Temperature Sensor, and Wiring Assembly

### Disassemble Wiring Assembly

1. Follow **Pressure Relief Procedure**, page 8. Shut off tank power and unplug power cord. Remove hose from applicator. Allow parts to cool before disassembling.
2. Disconnect applicator wire connector from hose connector.
3. **Disassemble Applicator Body**, page 14.
4. See FIG. 2. Note how wiring assembly (10) is positioned and seated in applicator body (1) channel.
5. Remove heat resistant tape holding wiring assembly (10) to fluid manifold (9). If black rubber tape comes off fluid manifold, discard.
6. Remove temperature sensor (10a) and heater (10b) from fluid manifold (9).
7. Remove reed switch (10c) from applicator body (1).
8. Using 1/16 allen wrench, loosen setscrew (31) in fluid manifold (9) and remove ground wire (green).
9. Pull wiring assembly (10) out of applicator body (1).

### Reassemble Wiring Assembly

1. See FIG. 2. Ensure that sharp hex edges of fluid manifold (9) are covered with black rubber tape, to prevent damage to wiring.
2. Install ground wire (green) in fluid manifold (9) and tighten setscrew (31), using 1/16 allen wrench.

3. Install temperature sensor (10a) and heater (10b) in fluid manifold (9). Secure wires to fluid manifold, using heat resistant tape.
4. Glue reed switch (10c) in position, using clear silicone.
5. Push reed switch leadwires into channel of applicator body (1) first, then push wiring assembly (10) over the top of them. Make sure wiring assembly is well seated in applicator body.
6. **Reassemble Applicator Body**, page 14.

## Replace Motor Switch Trigger



Motor Trigger Kit 118165 is available to replace the motor switch trigger assembly. The kit includes a trigger, spring (32), magnet (36), and bushing (26). Parts included in the kit are marked with a symbol, for example (32\*)

1. Follow **Pressure Relief Procedure**, page 8. Shut off tank power and unplug power cord. Remove hose from applicator. Allow parts to cool before disassembling.
2. **Disassemble Applicator Body**, page 14.
3. See FIG. 2. Remove old motor trigger (8) and attached parts. Remove spring (32).
4. Install Motor Trigger Kit 118165. Check that spring (32\*) is in place.
5. **Reassemble Applicator Body**, page 14.

# Parts

Part No. 118066 Manual Applicator, bottom feed, 115 Vac

Part No. 118067 Manual Applicator, bottom feed, 230 Vac

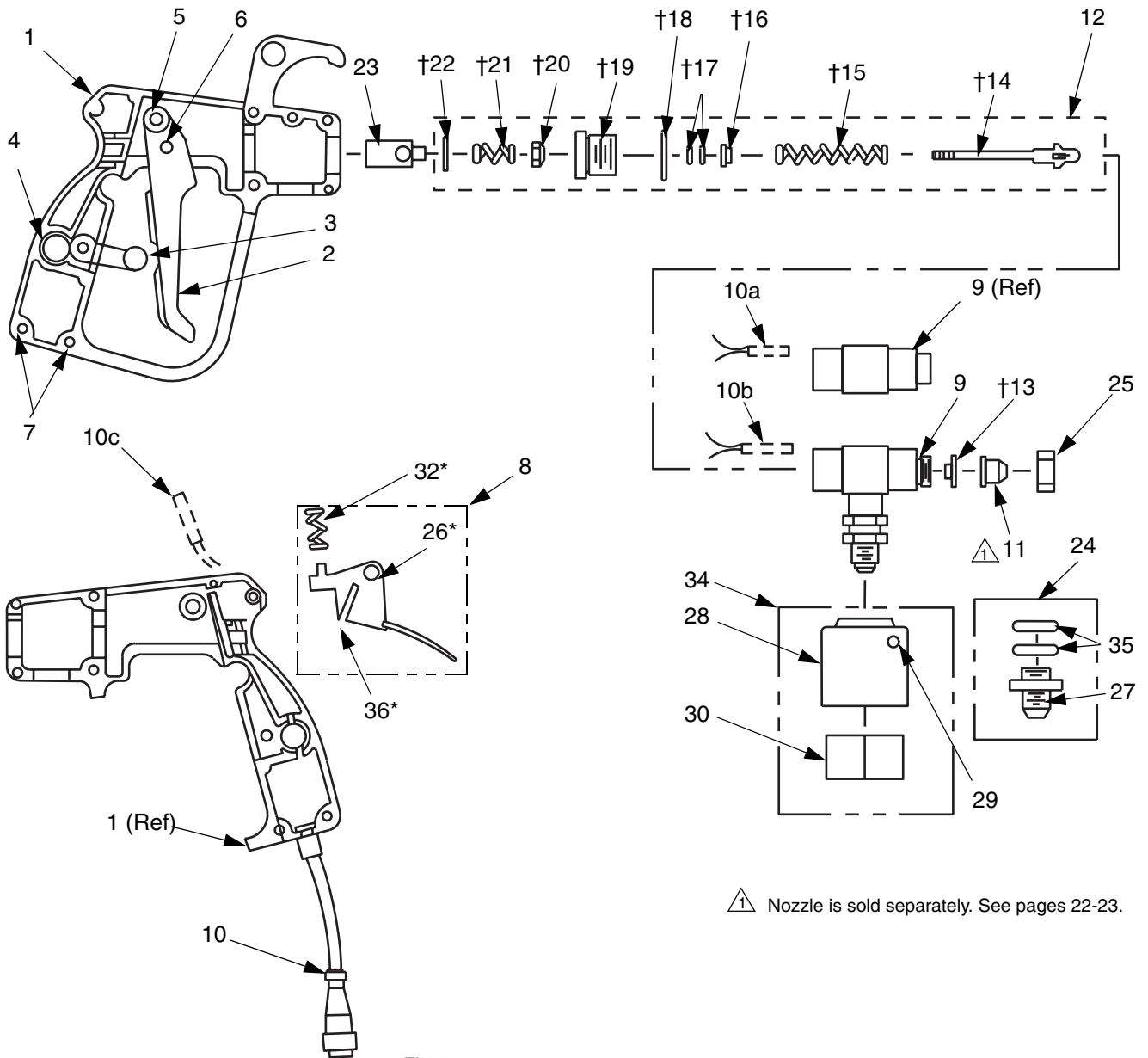

⚠ Nozzle is sold separately. See pages 22-23.

**Part No. 118066 Manual Applicator, bottom feed, 115 Vac****Part No. 118067 Manual Applicator, bottom feed, 230 Vac**

Ref. No.	Part No.	Description	Qty.	Ref. No.	Part No.	Description	Qty.
1	118450	BODY, applicator; both sides	1	20†	118385	NUT, handle retainer	1
2	118257	TRIGGER, applicator	1	21†		SPRING, trigger stop	1
3		LOCK, trigger	1	22†		WASHER, flat; 3/16	1
4		SPRING, ring lock	1	23		HANDLE, rocker	1
5		PIN, roll; 1/4 x 1 in.	1	24	118162	SWIVEL REPAIR KIT; includes items 27 and 35	1
6		PIN, roll; 3/16 x 3/4 in.	1	25	118226	NUT, nozzle	1
7		SCREW; #8 x 3/4 in.	7	26*		BUSHING, trigger	1
8	118165	MOTOR SWITCH TRIGGER KIT; includes items 26, 32, and 36	1	27		END, swivel male JIC	1
9	118348	FLUID MANIFOLD	1	28		SHIELD, swivel housing	2
10		WIRING ASSY; includes items 10a-10h, see page 27	1	29		SCREW; M4 x 14	2
	118215	120 Vac		30		INSULATION, heat shield	1
	118216	230 Vac		31		SCREW, set; 6-32 x 1/8 in.	1
11		NOZZLE; sold separately; see pages 22-23	1	32*		SPRING, motor trigger	1
12	118164	NEEDLE REBUILD KIT; includes items 13-22	1	33	118227	HOOK, hanger	1
13†	118225	SEAT, needle	1	34	118163	KIT, swivel insulation; includes items 28, 29, and 30	1
14†		NEEDLE, applicator	1	35		O-RING	2
15†		SPRING, needle	1	36*		MAGNET, switch	1
16†		GUIDE, needle	1				
17†		O-RING	2				
18†		O-RING	1				
19†		SEAL, housing	2				

\* Parts included in Motor Switch Trigger Kit 118165 (purchase separately).

† Parts included in Needle Rebuild Kit 118164 (purchase separately).

**Part No. 117888 Manual Applicator, top feed, 115 Vac**

**Part No. 117889 Manual Applicator, top feed, 230 Vac**

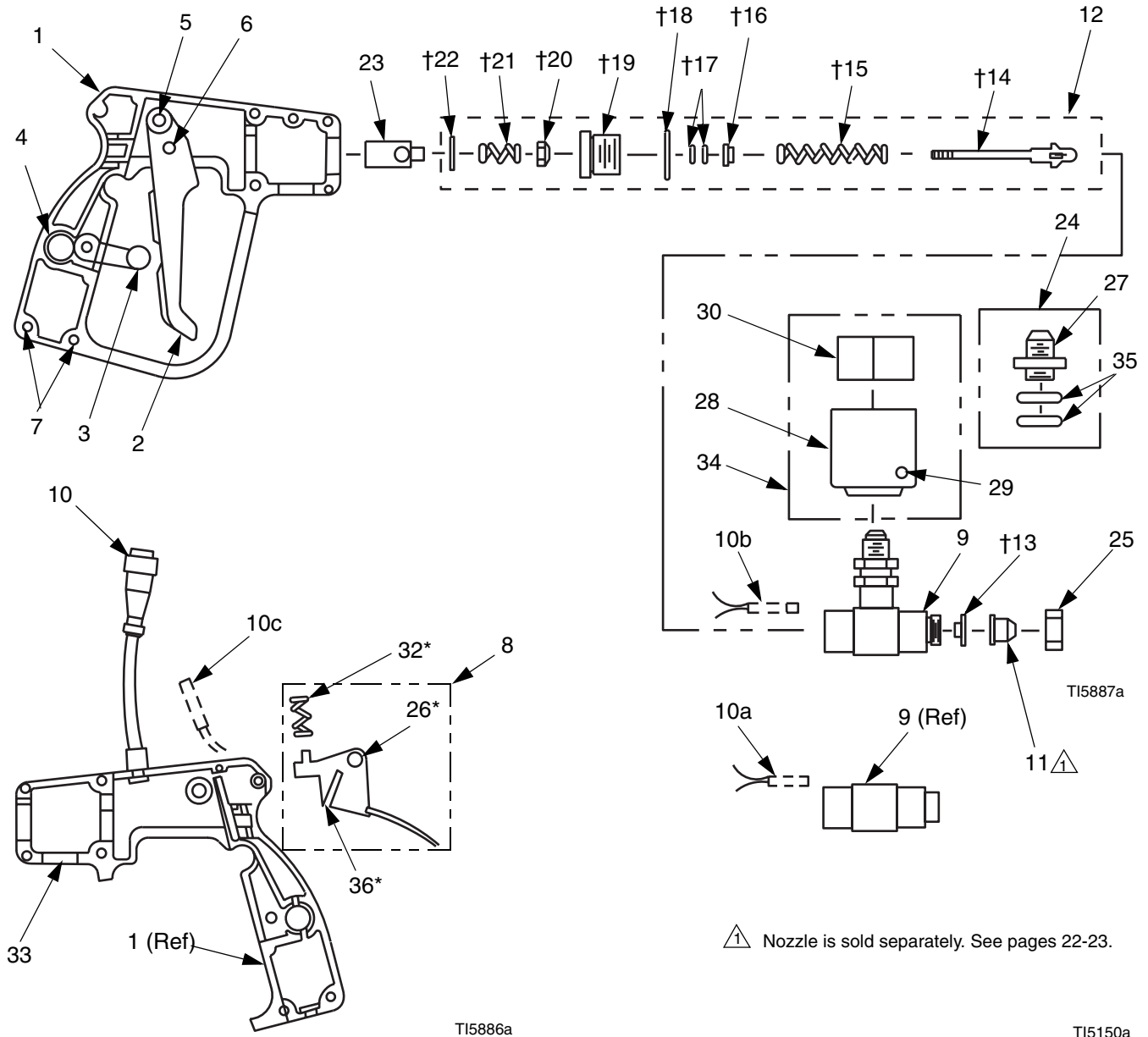

**Part No. 117888 Manual Applicator, top feed, 115 Vac****Part No. 117889 Manual Applicator, top feed, 230 Vac**

Ref. No.	Part No.	Description	Qty.	Ref. No.	Part No.	Description	Qty.
1	118450	BODY, applicator; both sides	1	20†	118385	NUT, handle retainer	1
2	118257	TRIGGER, applicator	1	21†		SPRING, trigger stop	1
3		LOCK, trigger	1	22†		WASHER, flat; 3/16	1
4		SPRING, ring lock	1	23		HANDLE, rocker	1
5		PIN, roll; 1/4 x 1 in.	1	24	118162	SWIVEL REPAIR KIT; includes items 27 and 35	1
6		PIN, roll; 3/16 x 3/4 in.	1	25	118226	NUT, nozzle	1
7		SCREW; #8 x 3/4 in.	7	26*		BUSHING, trigger	1
8	118165	MOTOR SWITCH TRIGGER KIT; includes items 26, 32, and 36	1	27		END, swivel male JIC	1
9	118348	FLUID MANIFOLD	1	28		SHIELD, swivel housing	2
10		WIRING ASSY; includes items 10a-10h, see page 27	1	29		SCREW; M4 x 14	2
	118215	120 Vac		30		INSULATION, heat shield	1
	118216	230 Vac		31		SCREW, set; 6-32 x 1/8 in.	1
11		NOZZLE; sold separately; see pages 22-23	1	32*		SPRING, motor trigger	1
				33		PLUG	1
12	118164	NEEDLE REBUILD KIT; includes items 13-22	1	34	118163	KIT, swivel insulation; includes items 28, 29, and 30	1
13†	118225	SEAT, needle	1	35		O-RING	2
14†		NEEDLE, applicator	1	36*		MAGNET, switch	1
15†		SPRING, needle	1				
16†		GUIDE, needle	1				
17†		O-RING	2				
18†		O-RING	1				
19†		SEAL, housing	2				

\* Parts included in Motor Switch Trigger Kit 118165 (purchase separately).

† Parts included in Needle Rebuild Kit 118164 (purchase separately).

# Accessories

## Extrusion Hoses

Hose Part No.	Length	Vac
117852	4 ft (1.2 m)	115
117853	6 ft (1.8 m)	115
117854	8 ft (2.4 m)	115
117855	10 ft (3 m)	115
117856	12 ft (3.6 m)	115
117857	16 ft (4.8 m)	115
117858	18 ft (5.4 m)	115
117859	24 ft (7.3 m)	115
117860	4 ft (1.2 m)	230
117861	6 ft (1.8 m)	230
117862	8 ft (2.4 m)	230
117863	10 ft (3 m)	230
117864	12 ft (3.6 m)	230
117865	16 ft (4.8 m)	230
117866	18 ft (5.4 m)	230
117867	20 ft (6 m)	230
117868	24 ft (7.3 m)	230

## Swirl/Spray Hoses

Hose Part No.	Length	Vac
117872	4 ft (1.2 m)	115
117873	6 ft (1.8 m)	115
117874	8 ft (2.4 m)	115
117875	10 ft (3 m)	115
117876	12 ft (3.6 m)	115
117877	16 ft (4.8 m)	115
117878	18 ft (5.4 m)	115
117879	24 ft (7.3 m)	115
117880	4 ft (1.2 m)	230
117881	6 ft (1.8 m)	230
117882	8 ft (2.4 m)	230
117883	10 ft (3 m)	230
117884	12 ft (3.6 m)	230
117885	16 ft (4.8 m)	230
117886	18 ft (5.4 m)	230
117887	24 ft (7.3 m)	230

## Swirl Assemblies

Part No.	Description	Orifice Size (in.)
118072	Swirl adapter (order nozzle separately)	n/a
117950	Swirl nozzle	.030
117951	Swirl nozzle	.045
117952	Swirl nozzle	.060
117953	Swirl nozzle	.080



FIG. 3: Swirl Assembly (shown with nozzle)

## Spray Assemblies

Part No.	Description	Orifice Size (in.)
118073	Spray adapter (order nozzle separately)	n/a
117940	Spray nozzle	.020
117941	Spray nozzle	.030
117942	Spray nozzle	.040
117943	Spray nozzle	.050



FIG. 4: Spray Assembly (shown without nozzle)

**Standard Extrusion Nozzles, 0.5 in. (13 mm)**

Part No.	Orifice Size (in.)
117890	.020
117891	.030
117892	.040
117893	.050
117894	.060
117895	.070
117896	.080
117897	.090

**Extrusion Nozzles, 3 in. (76 mm)**

Part No.	Orifice Size (in.)
117914	.020
117915	.030
117916	.040
117917	.050
117918	.060
117919	.070
117920	.080
117921	.090

**Extrusion Nozzles, 1 in. (25 mm)**

Part No.	Orifice Size (in.)
117898	.020
117899	.030
117900	.040
117901	.050
117902	.060
117903	.070
117904	.080
117905	.090

**Button Nozzles**

Part No.	Orifice Size (in.)
117930	.012
117931	.015
117932	.025
117933	.030
117934	.040
117935	.050
117936	.060
117937	.070
117938	.080
117939	.090

**Extrusion Nozzles, 2 in. (51 mm)**

Part No.	Orifice Size (in.)
117906	.020
117907	.030
117908	.040
117909	.050
117910	.060
117911	.070
117912	.080
117913	.090

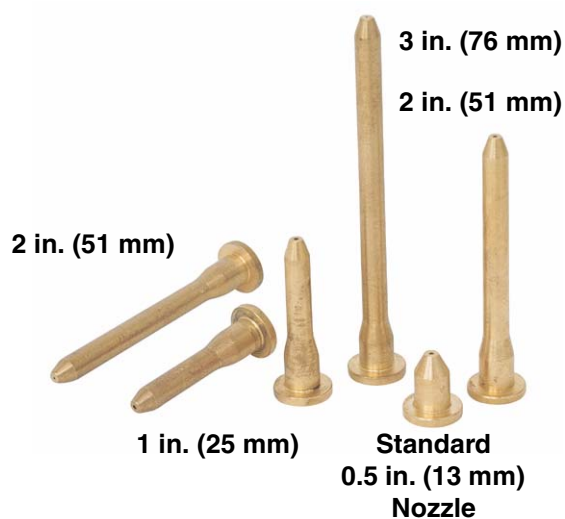

**FIG. 5: Extrusion Nozzles**

**T-Bar and Taper Conversion Bars**

Part No.	Description
117970	T-bar for manual applicator, four .020" orifices
117971	T-bar for manual applicator, four .030" orifices
117972	T-bar for manual applicator, four .040" orifices
117990	Taper conversion bar, 115 V, right side mount
117991	Taper conversion bar, 230 V, right side mount
117992	Taper conversion bar, 115 V, left side mount
117993	Taper conversion bar, 230 V, left side mount

**Aim Nozzle Assemblies, for T-Bar or Taper Conversion Bar**

Part No.	Description	Orifice Size (in.)
117980	Aim nozzle assembly. Includes o-rings.	.010

Part No.	Description	Orifice Size (in.)
117981	Aim nozzle assembly. Includes o-rings.	.020
117982	Aim nozzle assembly. Includes o-rings.	.030
117983	Aim nozzle assembly. Includes o-rings.	.040
117976	Aim nozzle	.010
117977	Aim nozzle	.020
117978	Aim nozzle	.030
117979	Aim nozzle	.040
118074	Aim nozzle screws, package of 5	n/a
118075	Aim nozzle o-ring kit, package of 10	n/a
118076	Aim nozzle blanking screws, use in T-bar to close off nozzle	n/a





A series of horizontal lines spanning the width of the page, providing a template for writing.

# Schematics

## Hose

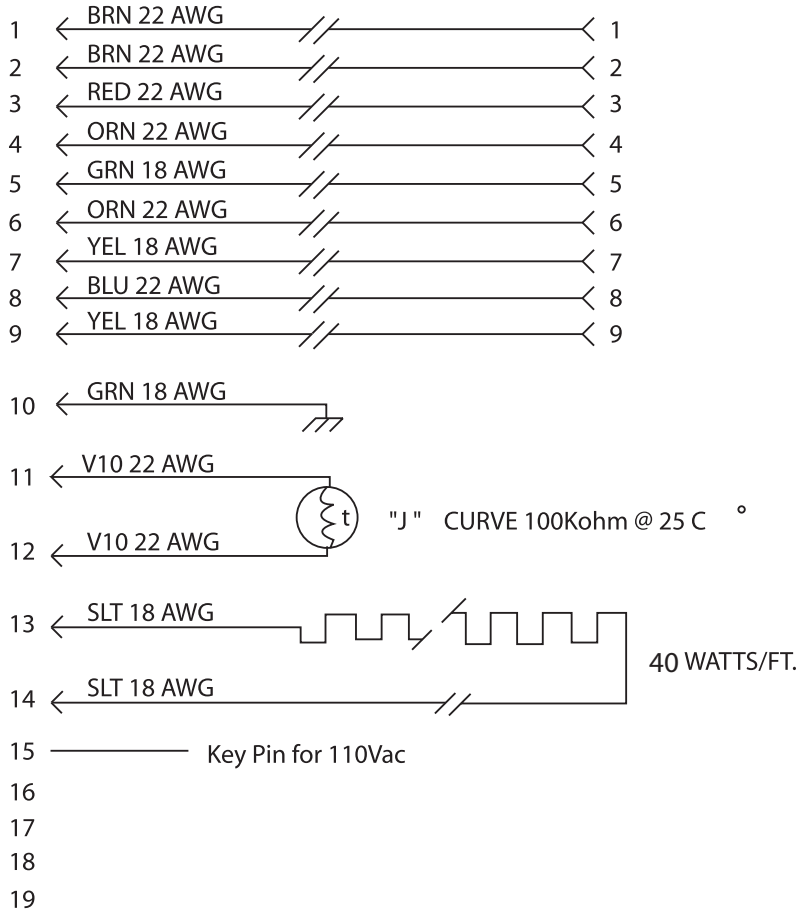

T15906a

### Extrusion Hose

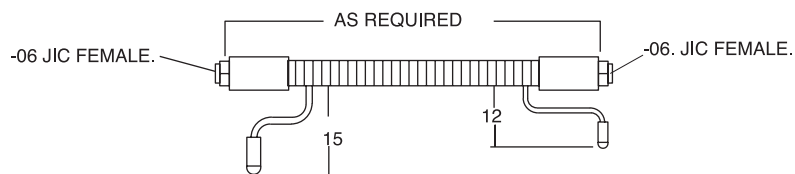

T15907a

### Air Spray/Swirl Hose

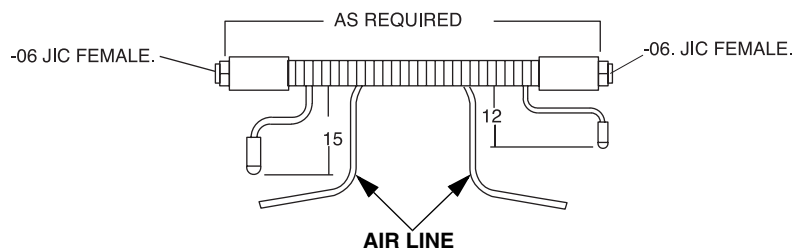

T16285a

### Applicator

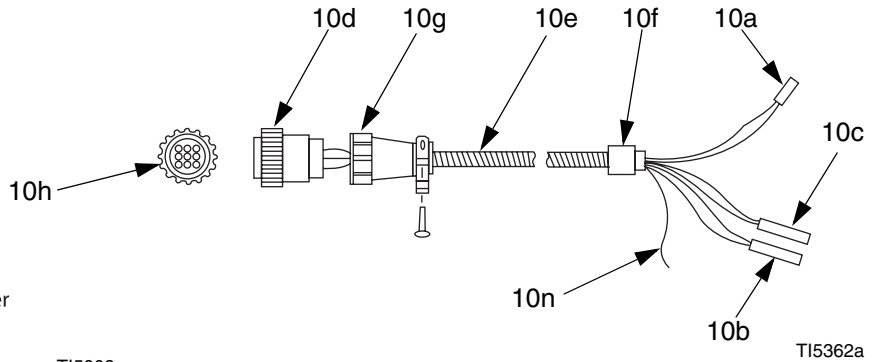
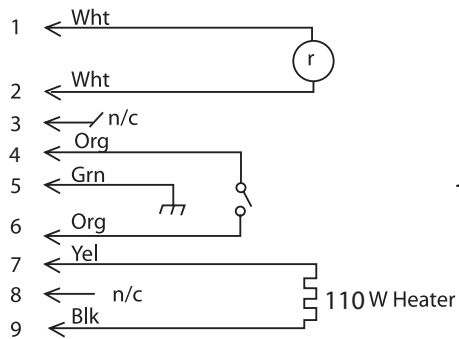

TI5908a

TI5362a

Ref. No.	Part No.	Description	Qty.	Ref. No.	Part No.	Description	Qty.
10a		SENSOR	1	10e		HOUSING, armored wire	1
10b		HEATER	1	10f		COLLAR, wire	1
10c		SWITCH, magnetic reed	1	10g		STRAIN RELIEF	1
10d		CONNECTOR, 9 pin, male	1	10h		PIN, male	8
				10n		GROUND	1

## Technical Data

Application temperature	up to 425°F (218°C)
Maximum fluid working pressure	3500 psi (23.3 MPa, 233 bar)
Viscosity range	up to 20,000 centipoise
Weight	1.7 lb (0.7 kg)
Voltage	<i>Models 117888 and 118066: 115 Vac, 50/60 Hz</i> <i>Models 117889 and 118067: 230 Vac, 50/60 Hz</i>
Heater watts	<i>Models 117888 and 118066: 110 W</i> <i>Models 117889 and 118067: 220 W</i>
Wetted parts	Brass, aluminum, Viton®

*All brand names or marks are used for identification purposes and are trademarks of their respective owners.*

# Dimensions

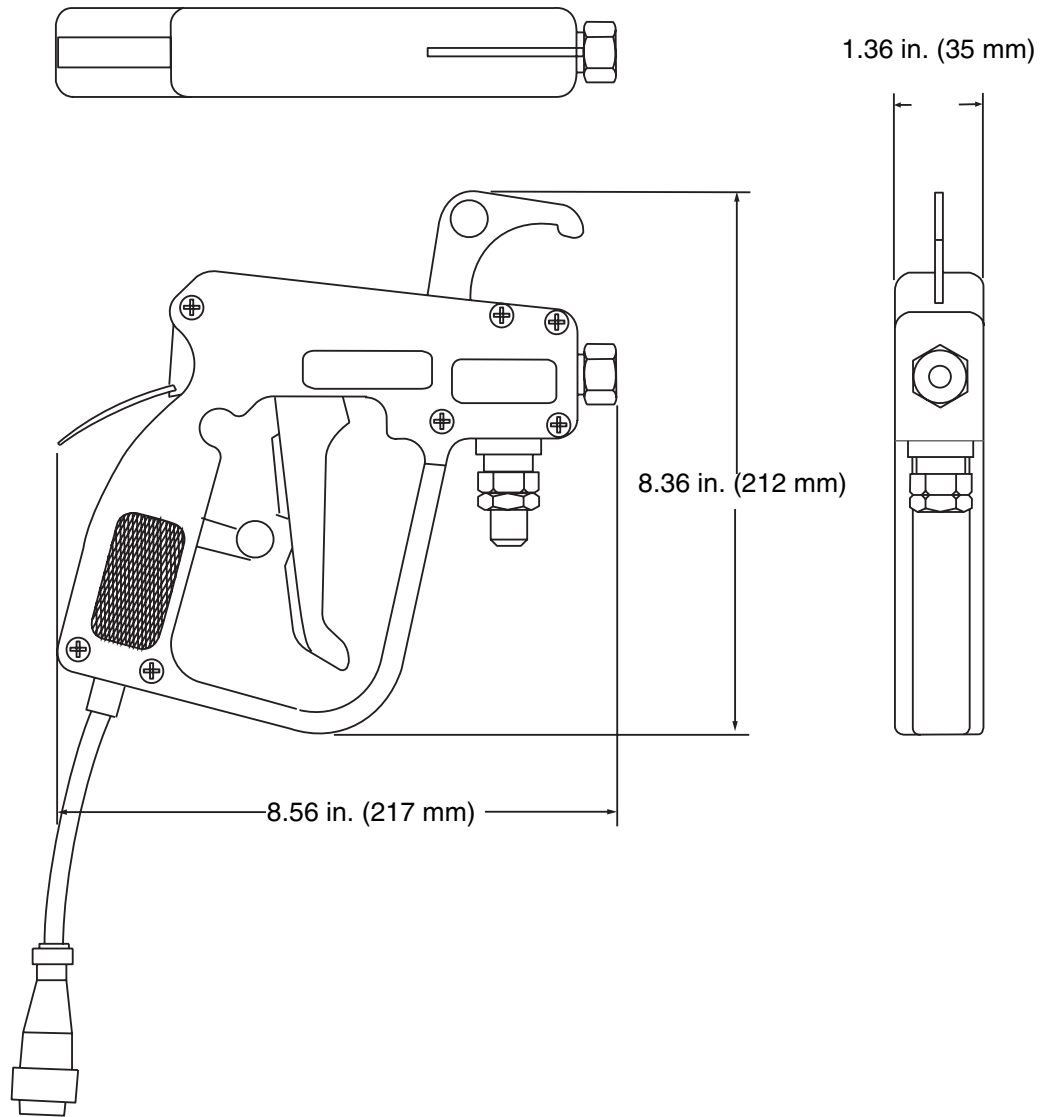

# Graco Standard Warranty

Graco warrants all equipment referenced in this document which is manufactured by Graco and bearing its name to be free from defects in material and workmanship on the date of sale to the original purchaser for use. With the exception of any special, extended, or limited warranty published by Graco, Graco will, for a period of twelve months from the date of sale, repair or replace any part of the equipment determined by Graco to be defective. This warranty applies only when the equipment is installed, operated and maintained in accordance with Graco's written recommendations.

This warranty does not cover, and Graco shall not be liable for general wear and tear, or any malfunction, damage or wear caused by faulty installation, misapplication, abrasion, corrosion, inadequate or improper maintenance, negligence, accident, tampering, or substitution of non-Graco component parts. Nor shall Graco be liable for malfunction, damage or wear caused by the incompatibility of Graco equipment with structures, accessories, equipment or materials not supplied by Graco, or the improper design, manufacture, installation, operation or maintenance of structures, accessories, equipment or materials not supplied by Graco.

This warranty is conditioned upon the prepaid return of the equipment claimed to be defective to an authorized Graco distributor for verification of the claimed defect. If the claimed defect is verified, Graco will repair or replace free of charge any defective parts. The equipment will be returned to the original purchaser transportation prepaid. If inspection of the equipment does not disclose any defect in material or workmanship, repairs will be made at a reasonable charge, which charges may include the costs of parts, labor, and transportation.

**THIS WARRANTY IS EXCLUSIVE, AND IS IN LIEU OF ANY OTHER WARRANTIES, EXPRESS OR IMPLIED, INCLUDING BUT NOT LIMITED TO WARRANTY OF MERCHANTABILITY OR WARRANTY OF FITNESS FOR A PARTICULAR PURPOSE.**

Graco's sole obligation and buyer's sole remedy for any breach of warranty shall be as set forth above. The buyer agrees that no other remedy (including, but not limited to, incidental or consequential damages for lost profits, lost sales, injury to person or property, or any other incidental or consequential loss) shall be available. Any action for breach of warranty must be brought within two (2) years of the date of sale.

**GRACO MAKES NO WARRANTY, AND DISCLAIMS ALL IMPLIED WARRANTIES OF MERCHANTABILITY AND FITNESS FOR A PARTICULAR PURPOSE, IN CONNECTION WITH ACCESSORIES, EQUIPMENT, MATERIALS OR COMPONENTS SOLD BUT NOT MANUFACTURED BY GRACO.** These items sold, but not manufactured by Graco (such as electric motors, switches, hose, etc.), are subject to the warranty, if any, of their manufacturer. Graco will provide purchaser with reasonable assistance in making any claim for breach of these warranties.

In no event will Graco be liable for indirect, incidental, special or consequential damages resulting from Graco supplying equipment hereunder, or the furnishing, performance, or use of any products or other goods sold hereto, whether due to a breach of contract, breach of warranty, the negligence of Graco, or otherwise.

## **FOR GRACO CANADA CUSTOMERS**

The Parties acknowledge that they have required that the present document, as well as all documents, notices and legal proceedings entered into, given or instituted pursuant hereto or relating directly or indirectly hereto, be drawn up in English. Les parties reconnaissent avoir convenu que la rédaction du présente document sera en Anglais, ainsi que tous documents, avis et procédures judiciaires exécutés, donnés ou intentés, à la suite de ou en rapport, directement ou indirectement, avec les procédures concernées.

# Graco Information

**TO PLACE AN ORDER**, contact your Graco distributor or call to identify the nearest distributor.

**Phone:** 612-623-6921 **or Toll Free:** 1-800-328-0211 **Fax:** 612-378-3505

*All written and visual data contained in this document reflects the latest product information available at the time of publication.  
Graco reserves the right to make changes at any time without notice.*

MM 310801

**Graco Headquarters:** Minneapolis  
**International Offices:** Belgium, China, Japan, Korea

**GRACO INC. P.O. BOX 1441 MINNEAPOLIS, MN 55440-1441**

[www.graco.com](http://www.graco.com)

Printed in USA 310801B

11/2005