

Line Driver®

Model 233725

U.S. Patent Number 6,883,633



Important Safety Instructions

Read all warnings and instructions in this manual.
Save these instructions.

10 mph (16 kph) Maximum Operating Speed

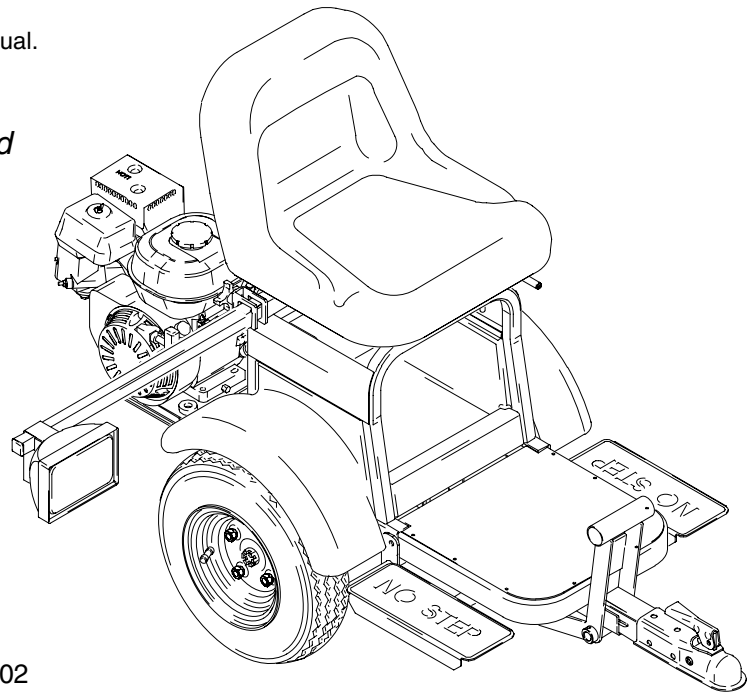

Related Manuals

Operation	309402
Hitch Receiver Kit 245321	309405
Battery Kit 245343	309406

ti650a

Table of Contents

Warnings	2	Engine	8
General Repair Information	3	Variable Displacement Pump	9
Maintenance	3	Parts Drawing	10
Troubleshooting	4	Parts List	11
Transmission and Brake Adjustments	5	Technical Data	15
Tire and Wheel Motors	6	Graco Phone Number	15
Battery/Light Regulator	7	Graco Warranty	16



WARNING

MOVING VEHICLE HAZARD

Careless and reckless behavior causes accidents. Falling from vehicle, running into people or objects, or being struck by other vehicles may result in serious injury or death.

- Use appropriate traffic control in all traffic areas
- Do not step on forward/reverse pedals
- Make turns slowly
- Do not carry passengers
- Do not operate on slopes greater than 15°
- Loss of traction may occur going downhill
- Reference Manual on Uniform Traffic Control Devices (MUTCD), U.S. Department of Transportation, Federal Highway Administration or local highway and transportation regulations for proper traffic control.
- Do not make turns greater than 45°
- Do not tow
- Use with line striping equipment only



MOVING VEHICLE HAZARD

Careless and reckless behavior causes accidents. Falling from vehicle, running into people or objects, or being struck by other vehicles may result in serious injury or death.

- Use appropriate traffic control in all traffic areas
- Do not step on forward/reverse pedals
- Make turns slowly
- Do not carry passengers
- Do not operate on slopes greater than 15°
- Loss of traction may occur going downhill
- Reference Manual on Uniform Traffic Control Devices (MUTCD), U.S. Department of Transportation, Federal Highway Administration or local highway and transportation regulations for proper traffic control.
- Do not make turns greater than 45°
- Do not tow
- Use with line striping equipment only

FIRE AND EXPLOSION HAZARD

Fuel spilled on a hot surface can cause a fire or explosion and serious bodily injury or death. Shut off engine and let engine cool before filling tank.



FIRE AND EXPLOSION HAZARD

Fuel spilled on a hot surface can cause a fire or explosion and serious bodily injury or death. Shut off engine and let engine cool before filling tank.

HOT SURFACE HAZARD

Engine and drive housing may be very hot during operation and could burn skin if touched.



HOT SURFACE HAZARD

Engine and drive housing may be very hot during operation and could burn skin if touched.

TOXIC FUMES HAZARD

Engine produces carbon monoxide which is a deadly gas. Do not operate in an enclosed area. Breathing carbon monoxide may result in serious injury or death.



TOXIC FUMES HAZARD

Engine produces carbon monoxide which is a deadly gas. Do not operate in an enclosed area. Breathing carbon monoxide may result in serious injury or death.

General Repair Information

WARNING



MOVING PARTS HAZARD

To reduce risk of serious injury, do not touch moving parts with fingers or tools while testing repair. Shut off Line Driver when repairing. Install all covers, gaskets, screws and washers before operating Line Driver.

CAUTION

To reduce risk of electrical malfunction:

- Use needle nose pliers to disconnect wires. Never pull on wire, pull on connector.
- Mate wire connectors properly. Center flat blade of insulated male connector in female connector.
- Route wires carefully to avoid interference with other connections of pressure control. Do not pinch wires between cover and control box.

WARNING



HOT SURFACES HAZARD EXPLOSION HAZARD

Hydraulic reservoir and engine may be very hot during operation and could burn skin if touched.



Flammable materials spilled on hot engine could cause fire or explosion.

Maintenance

CAUTION

For detailed engine maintenance and specifications, refer to separate Honda Engines Owner's Manual, supplied.

DAILY: Check engine oil level and fill as necessary.

DAILY: Check hydraulic oil level and fill as necessary.

DAILY: Check and fill the gas tank.

AFTER THE FIRST 20 HOURS OF OPERATION:

Drain engine oil and refill with clean oil. Reference Honda Engines Owner's Manual for correct oil viscosity.

WEEKLY: Remove engine air filter cover and clean element. Replace element, if necessary. If operating in an unusually dusty environment: check filter daily and replace, if necessary.

Replacement elements can be purchased from your local HONDA dealer.

AFTER EACH 100 HOURS OF OPERATION:

Change engine oil. Reference Honda Engines Owner's Manual for correct oil viscosity.

YEARLY OR 500 HOURS:

Replace hydraulic oil and filter element. Use **Mobil 1** (15W-50) synthetic oil and Graco filter 245342.

Hydraulic Oil Replacement Procedure:

1. Remove filter and allow oil reservoir to drain from filter base.
2. Install new filter and fill oil reservoir to top of baffle with **Mobil 1** (15W-50) synthetic oil.
3. Manual 309402. Open drive wheel release. Start engine and run at low rpm for 3 minutes.
4. Close drive wheel release. Check oil level and top off to top of baffle.

SPARK PLUG: Use only BPR6ES (NGK) or W20EPR-U (NIPPONDENSO) plug. Gap plug to 0.028 to 0.031 in. (0.7 to 0.8 mm). Use spark plug wrench when installing and removing plug.

Troubleshooting

PROBLEM	CAUSE	SOLUTION
Engine does not start	Parking brake not engaged. Engine switch OFF, no gasoline or low oil	Set Brake. Consult engine manual, supplied
Engine races to high rpm – stalls during operation	Worn governor.	Consult engine manual, supplied
Engine operates, Line Driver does not move forward or reverse	Low hydraulic oil	Fill with Mobil 1 (15W–50) synthetic oil
Engine operates, Line Driver moves slowly in forward and reverse	Low hydraulic oil. Parking brake is set Wheel release is open.	Fill with Mobil 1 (15W–50) synthetic oil. Release parking brake. Close; hand tight.
Engine shuts off when operator exits Line Driver	Safety switch	Set parking brake
Engine continues to run when operator exits Line Driver and parking brake is not set	Safety switch	Adjust and set parking brake. Replace safety switch and/or any connecting wires.
Engine misses during turns and forward and reverse changes	Engine oil low	Consult engine manual for proper oil
Parking brake does not keep Line Driver from moving	Parking brake needs adjustment	Adjust brake. Manual 309404.
Line Driver creeps in forward or reverse direction	Hydraulic motor linkage needs adjustment	Adjust hydraulic motor linkage. Manual 309404.
Engine light does not turn on	Check light bulb Check connections Check Switch position on regulator	Replace light bulb Repair connections Set Switch position on regulator : 1. Set to No Battery if your Line Driver has no battery 2. Set to Battery if your Line Driver has a battery

Hydraulic Motor Linkage and Brake Adjustments

Hydraulic Motor Linkage

The Line Driver may creep forward or backwards when no pressure is applied to the pedals. This procedure helps to attain a neutral condition.

1. Set Line Driver on blocks so wheels are off ground.
2. Apply weight to center of seat to by-pass safety switch.
3. Release brake.
4. Fig. 1. Loosen jam nut (18).
5. Turn centering fitting (24) toward rear of Line Driver to stop forward creep. Turn centering fitting toward front to stop reverse creep.
6. Tighten jam nut (18).

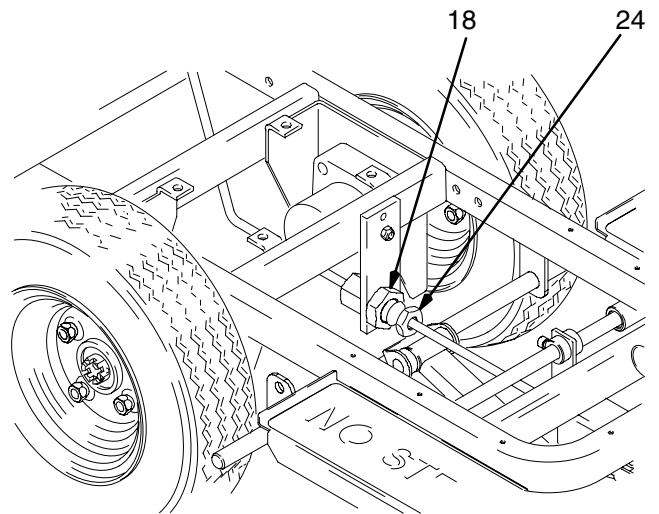

Fig. 1

ti654a

Brake

The Line Driver may roll if left unattended and brake not applied. The brake must be applied in order to start the engine. After a period of time, tire wear may cause a need to adjust the brake.

1. Fig. 2. Loosen two lock nuts (86) and bolts (77) securing brake bracket (62).
2. Slide brake bracket (62) forward or backward to attain desired brake pressure.
3. Tighten lock nuts (86) and bolts (77) securing brake bracket (62).

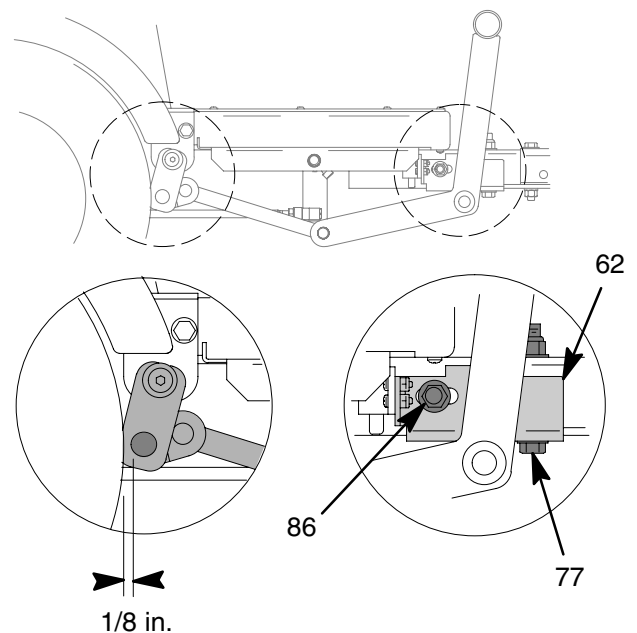

Fig. 2

ti653a

Tire and Wheel Motors

Hydraulic System Purging

Follow this procedure after replacing any hydraulic components:

1. Set Line Driver on blocks so wheels are off ground.
2. Fill oil reservoir to top of baffle.
3. Open drive wheel release two turns.
4. Start engine and run at low rpm.
5. Slowly move motion control pedals in forward and reverse directions 10 times.
6. Check oil level and top off to top of baffle.
7. Close drive wheel release and repeat step 5.
8. Increase speed. Move pedals to see if wheels turn freely.
9. Check oil level. Top off to top of baffle.

Tire

Removal

1. Fig. 3. Set Line Driver on blocks so wheels are off ground.
2. Remove four lug nuts (22) and tire (16).

Installation

1. Repair tire and install lug nuts. Alternately tighten lug nuts opposite of each other.
2. Tilt Line Driver back and remove blocks.

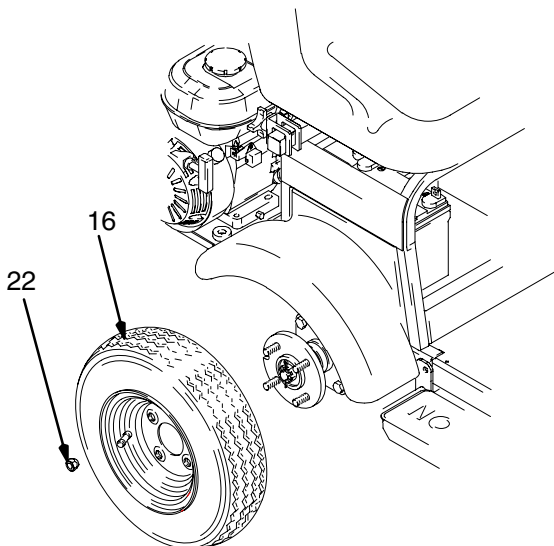

Fig. 3

ti655a

Wheel Motors

Removal

1. Fig. 3. Set Line Driver on blocks so wheels are off ground.
2. Remove four lug nuts (22a) and tire (16).
3. Remove pin (56), caster nut (21b) and wheel hub (22b). Wheel hub (22b) may require a wheel puller; not supplied by Graco.
4. Disconnect two hydraulic hoses (112) from wheel motor (21a). Elevate hose ends and plug.
5. Remove four bolts (78), lock nuts (79) and wheel motor (21a).

Installation

1. Install wheel motor (21) with four bolts (78) and lock nuts (79).
2. Connect two hydraulic hoses (112) to wheel motor (21).
3. Install wheel hub (22), caster nut (21), and pin (56).
4. Install tire (16) with four lug nuts (22).

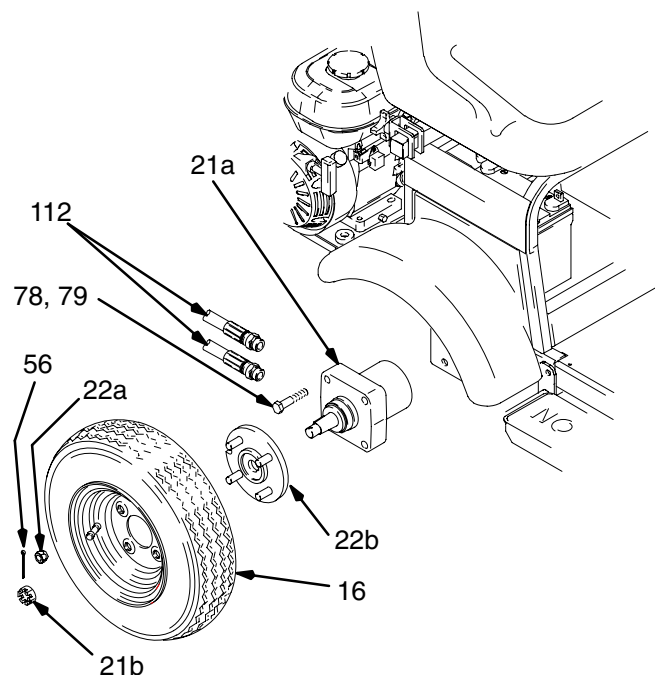

Fig. 4

ti655a

Battery/Light Regulator

Regulator

The regulator is located under the seat and converts the engine-generated ac voltage into a dc voltage for the battery and light.

Removal

1. Fig. 5. Unplug light cord (59) and disconnect leads (A, B).
2. Remove bolt (77) and nut (76) and regulator (126).

Installation

1. Fig. 5. Install regulator (126) with bolt (77) and nut (76).

2. Connect leads (A, B) and plug in light cord (59).

Battery Kit

The battery is located under the seat and stores the converted dc voltage for the battery and light.

Use only Graco Battery 115753. Install according to Manual 309406.

Important: Do not install other 12 Volt equipment without first installing Graco Battery Kit 245343.

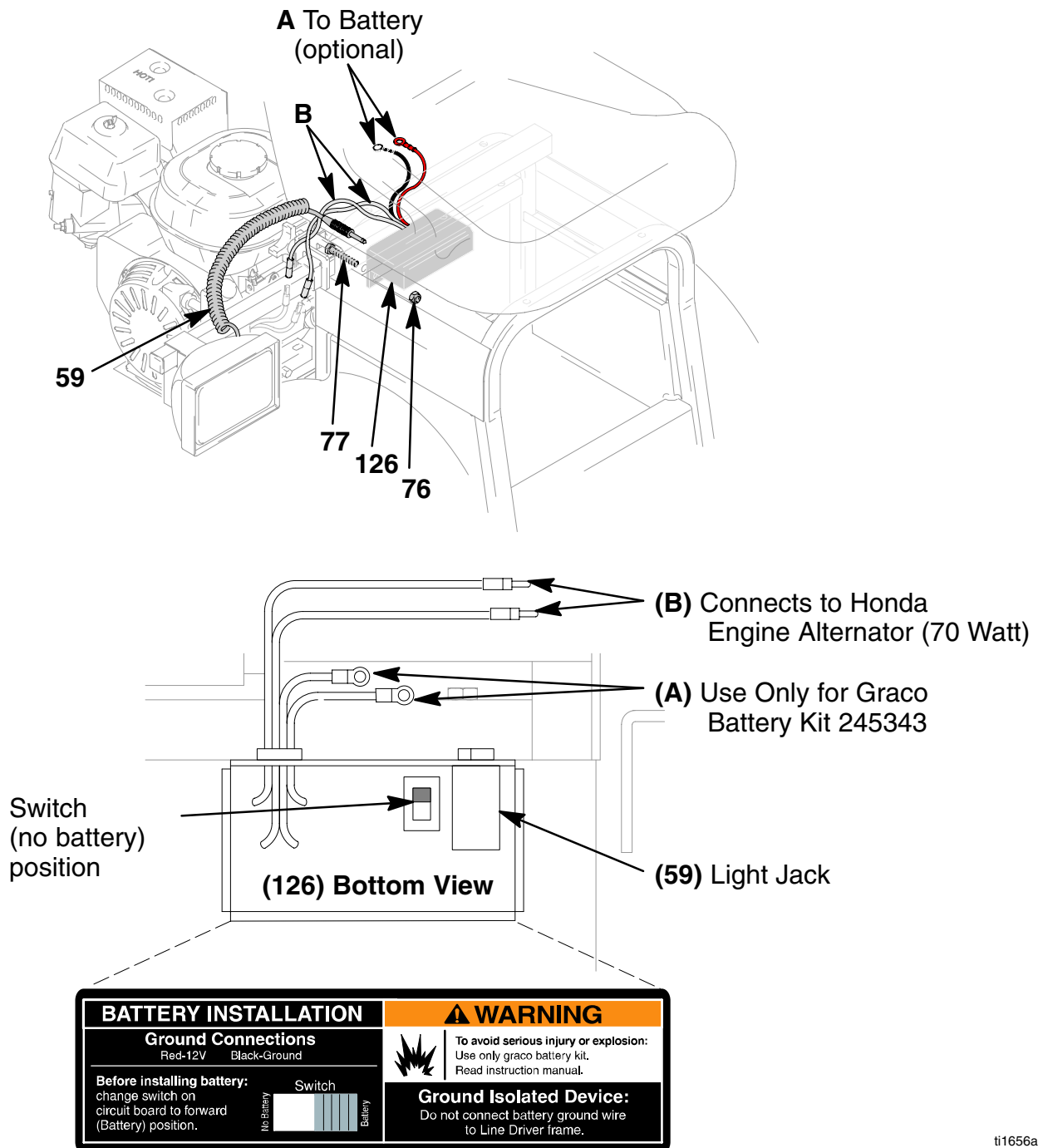

Fig. 5

ti1656a

Engine

Removal

1. Fig. 6. Remove cap screw (129), lock nut (130) and coupler guard (125).
2. Remove set screw (A) from flexible coupling (34).
3. Fig. 5. Disconnect all necessary wiring.
4. Remove four cap screws (70) and washers (71).
5. Fig. 6. Remove four engine mounting screws (69), lock nuts (82) and engine (3).

NOTE: All service to the engine must be performed by an authorized HONDA dealer.

Installation

1. Fig. 6. Remove four engine mounting screws (69), lock nuts (82) and engine (3). Torque to 200 in-lb (22.6 N•m).
2. Install four washers (71) and cap screws (70).
3. Fig. 5. Connect all necessary wiring.
4. Fig. 7. Install set screw (A) in flexible coupling (34).
5. Install coupler guard (125) with cap screw (129), and lock nut (130).

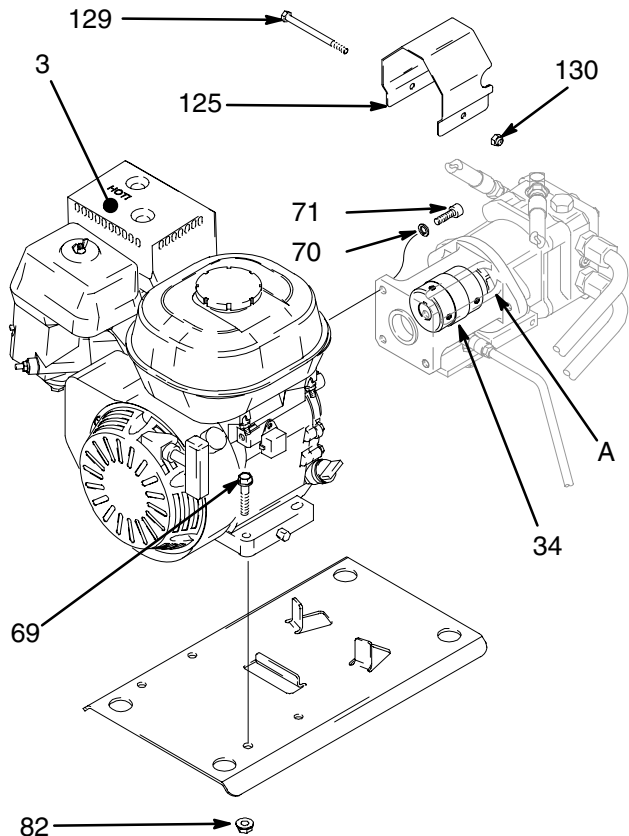

Fig. 6

ti657a

Variable Displacement Pump

Removal

1. Be prepared to plug hydraulic connections.
2. Fig. 7. Disconnect hydraulic lines (109, 110) and hoses (118, 119) from variable displacement pump (5).
3. Remove two cap screws (80), two lock washers (75) and two washers (74).
4. Remove cap screw (87) and washer (71) from control arm (58).
5. Remove cap screw (129), lock nut (130) and coupler guard (125).
6. Remove set screw (A) from flexible coupling (34) and remove variable displacement pump (5) and key (83).

Installation

1. Install variable displacement pump (5) and key (83). Install set screw (A) into flexible coupling (34).
2. Install coupler guard (125) with cap screw (129), and lock nut (130).
3. Install washer (71) and cap screw (87) into control arm (58).
4. Install two washers (74), two lock washers (75) and two cap screws (80).
5. Connect hydraulic lines (109, 110) and hoses (118, 119) to variable displacement pump (5).

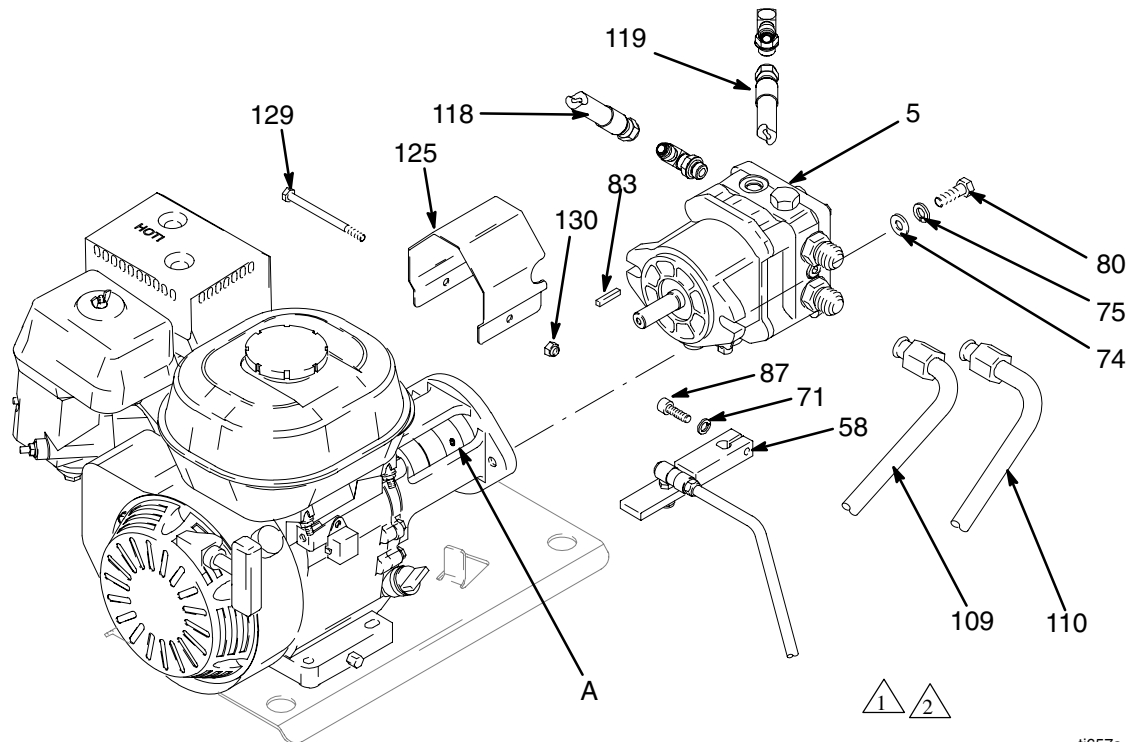
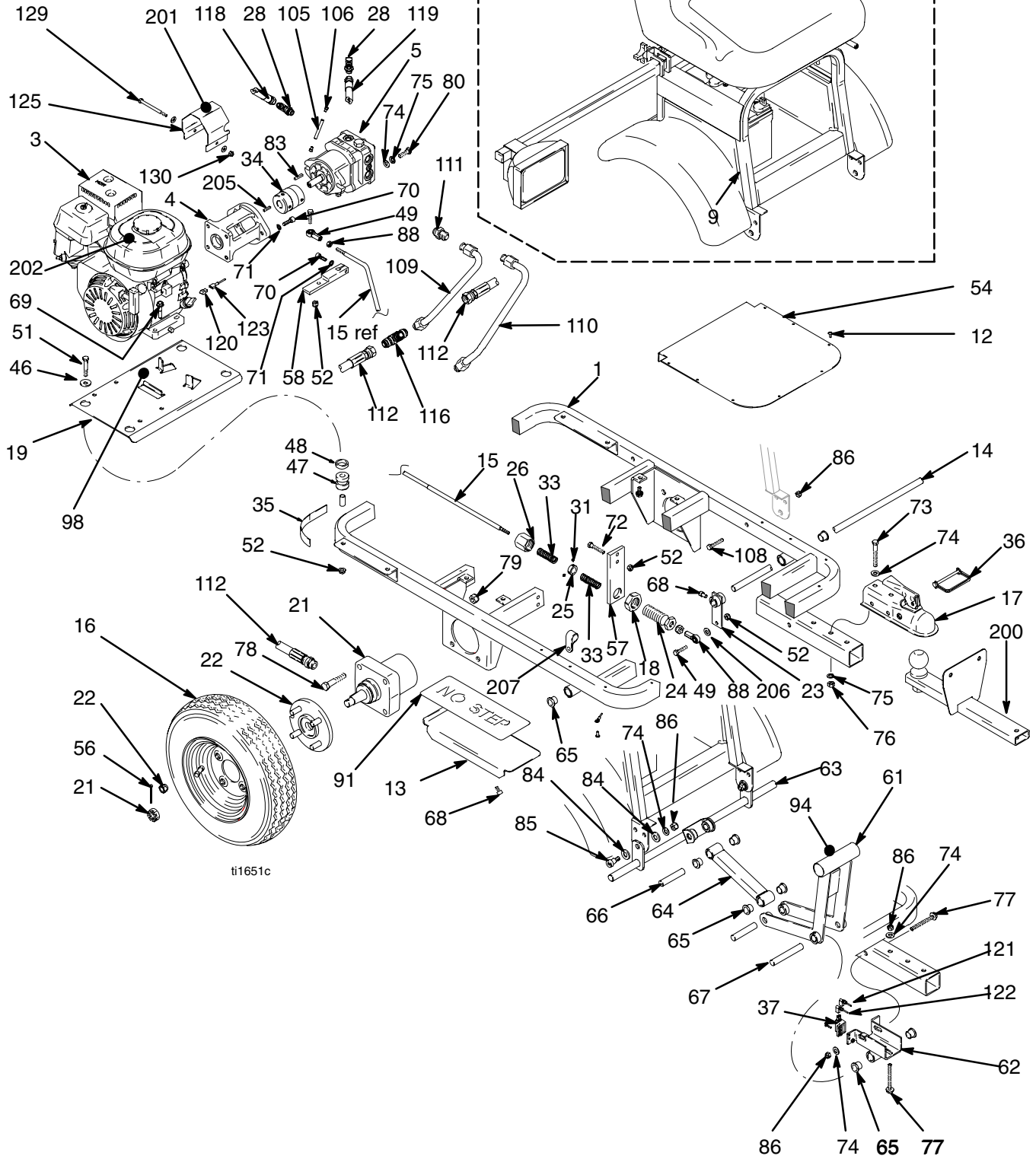

Fig. 7

ti657a

Parts Drawing

Page 12



ti1651c

Parts List

Ref No.	Part No.	Description	Qty	Ref No.	Part No.	Description	Qty
1	287679	FRAME, Line Driver	1	68	116940	SCREW, cap, socket head	6
3	114530	ENGINE, 5.5 HP, Honda	1	69	110837	SCREW, flange, hex	4
4	116873	BRACKET, mtg, hydro, pump	1	70	109031	SCREW, cap, sch	4
5	116810	PUMP, displacement, hydraulic	1	71	104008	WASHER, lock	5
12	198771	PLATE, floor (198769)	1	72	802127	SCREW, cap, hex hd	6
13	287684	PEDAL, foot, weldment	2	73	115348	SCREW, cap, 3/8-16 hex head	2
14	198814	SHAFT, foot pedals	1	74	100023	WASHER	8
15	287585	KIT, throttle, linkage Includes rod, 25 and 31)	1	75	100133	WASHER, lock	4
				76	100307	NUT, hex	2
16	245340	WHEEL, pneumatic, assy	2	77	116935	SCREW, cap, flnghd	2
17	116889	COUPLER, ball	1	78	114766	BOLT, cap, hex hd	8
18	116906	NUT, jam, hex	1	79	801020	NUT, lock, hex	8
19	198802	PLATE, mntng, mtr (198770)	1	80	100004	SCREW, cap, hex hd	2
21	116814	MOTOR, wheel with nuts	2	83	117222	KEY, square, 5 mm	1
22	116815	HUB, wheel, 4 bolt with nuts	2	84	109570	WASHER, plain	4
23	245313	ARM, linkage, weldment	1	85	116942	SCREW, shoulder, socket hd	1
24	198803	FITTING, centering	1	86	101566	NUT, lock	2
25	15F273	COLLAR, stop	1	88	100521	BOLT	2
26	198805	CAP, fitting, centering	1	91	198872	PAD, non-slip, pedal	2
28	116829	FITTING, 90° w/adj o-ring	1	94	198922	LABEL, caution	1
31	119663	SCREW, set	2	98	198920	LABEL, instruction	1
33	116888	SPRING, compression	2	105	116961	ROD, stand-off 1/4"	1
34	116875	COUPLING, flexible	1	106	111006	SCREW, cap	2
35	290159	LABEL, reflective	2	108	116780	SCREW, hex hd, flanged	4
36	113696	PIN, ball coupler	1	109	198950	TUBE, hydraulic, Line Driver	1
37	116890	SWITCH, plunger	1	110	198949	TUBE, hydraulic, Line Driver	1
46	108851	WASHER, plain	4	111	116966	FITTING, straight, hydraulic	2
47	195515	DAMPENER, motor mount	4	112	116878	HOSE, hydraulic	4
48	195516	SPACER	4	116	116965	FITTING, tee, hydraulic	2
49	116896	LINK, ball joint, qd	2	118	198954	HOSE, hydraulic	1
51	111302	SCREW, cap hex hd	4	119	198955	HOSE, hydraulic	1
52	110838	NUT, lock, nylock	8	120	114956	TERMINAL, wire tap, insulated	1
54	110037	SCREW, mach, pnh	8	123	198977	WIRE, switch, seat	1
56	100104	PIN	2	125	198984	GUARD, coupler	1
57	198806	GUIDE, rod	1	129	101530	SCREW, cap	1
58	198801	ARM, control, hydro	1	130	102040	NUT, lock	1
61	245336	LEVER, brake	1	200	245321	HITCH KIT, Includes ball and mounting hardware	2
62	245332	BRACKET, brake	1				
63	245334	HANGER, rod, brake	1	201	290228	LABEL, caution	1
64	245333	ARM, brake	1	202	194126	LABEL, warning	1
65	116937	BEARING, flange, bronze	10	205	113267	KEY, square, 3/16 in.	1
66	198889	SHAFT, brake	2	206	100527	WASHER	1
67	198890	SHAFT, brake	1	207	111483	CLAMP, cable	1

Parts Drawing

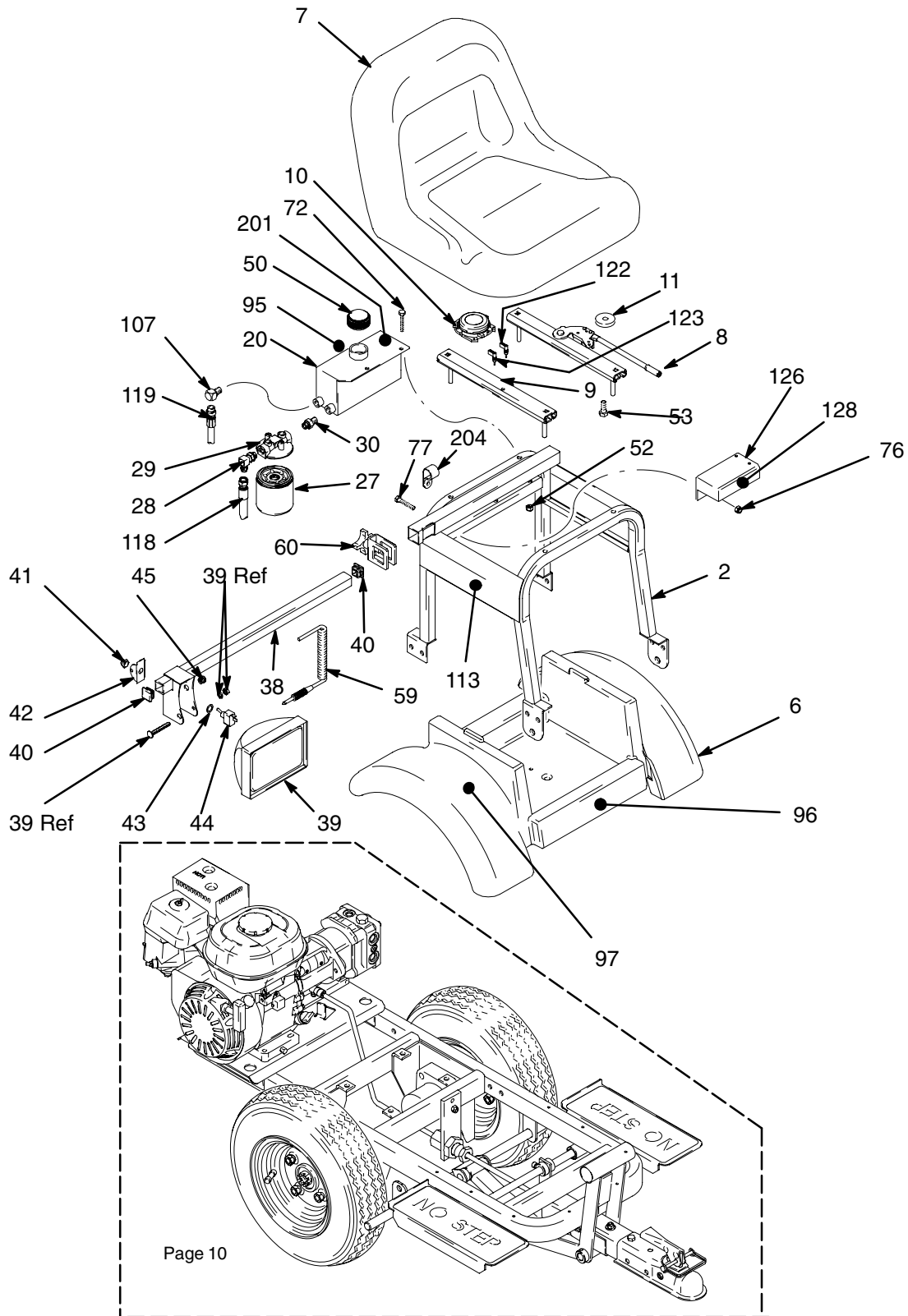

Parts List

Ref No.	Part No.	Description	Qty	Ref No.	Part No.	Description	Qty
2	287686	CARRIAGE, seat, Line Driver	1	52	110838	NUT, lock, nylock	8
6	198713	FENDER, Line Driver	1	53	100040	PLUG, pipe	4
7	245341	SEAT, with switch	1	59	116910	CORD, power, Line Driver	1
8	116827	BRACKET, adjust, seat	1	60	224071	CLAMP, extension	1
9	116877	BRACKET, adjust, seat, slave	1	72	802127	SCREW, cap, hex hd	6
10	116833	SWITCH, safety, seat	1	76	100307	NUT, hex	2
11	116832	SPACER, seat	4	77	116935	SCREW, cap, flnghd	2
20	116826	RESERVOIR, hydraulic	1	95	198921	LABEL	1
27	245342	FILTER, oil	1	96	198919	LABEL	1
28	116829	FITTING, 90° w/adj o-ring	1	97	198918	LABEL	2
29	116828	HOUSING, oil filter	1	107	100840	ELBOW, street	1
30	116837	FITTING, straight, o-ring	1	113	198953	LABEL, instruction	2
38	287678	ARM, mounting, light	1	118	198954	HOSE, hydraulic	1
39	116892	LIGHT, halogen	1	119	198955	HOSE, hydraulic	1
40	116895	CAP, tube, square	2	122	198976	WIRE, switch, brake	1
41	195428	BOOT, toggle	1	123	198977	WIRE, switch, seat	1
42	107255	GUARD, switch	1	126	245421	REGULATOR, battery/light	1
43	105658	RING, locking	1	128	198958	LABEL	1
44	111930	SWITCH, toggle	1	201	290228	LABEL, caution	1
45	114425	BUSHING, strain relief	1	204	108868	CLAMP, wires	2
50	116831	CAP, hydraulic, reservoir	1				

Safety Interlock Wiring Diagram

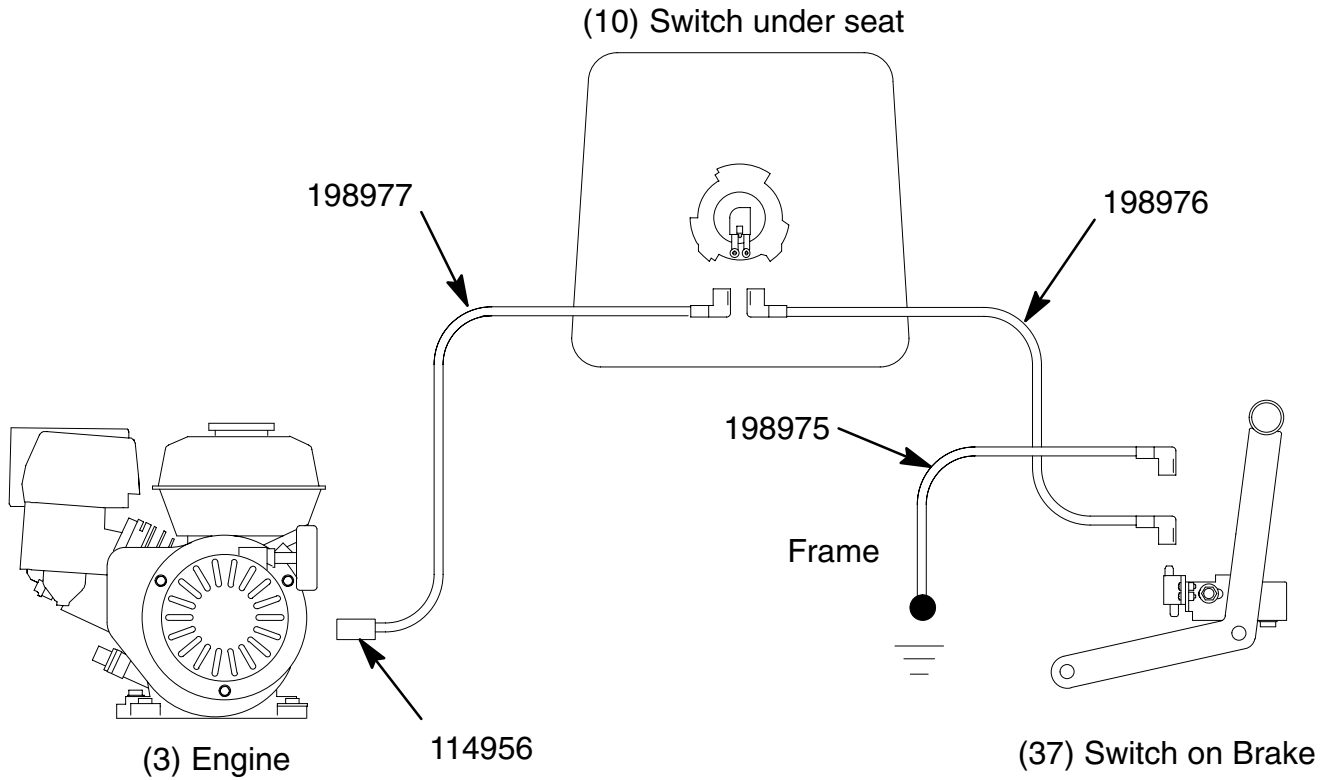

ti1672a

Safety Interlock Test Procedure

The Line Driver safety Interlock prevents the engine from running if the parking brake is not set and the driver leaves the seat. Periodically check the interlock.

1. Set parking brake.
2. Sit on Line Driver seat.
3. Start engine.
4. Release parking brake.
5. Get off the Line Driver seat.
6. If engine stalls, safety interlock operates correctly.

Technical Data

Hydraulic Pressure psi (bar)	Hydraulic System Capacity Quarts (Liters)	Engine HP	Engine Generator Output Watt
2700 (186)	2 (1.9)	5.5 DIN 6270 B/DIN 6271 NA .2.9 Kw – 4.0 Ps NB .3.6 Kw – 4.9 Ps	70

Dimensions

Model	Weight lb (kg)	Height in. (cm)	Width in. (cm)	Length in. (cm)
233725	246 (111)	41 (104)	26 (66)	58 (147)

Sound Levels

Line driver (Operating Range)*:

Sound Pressure 94–99 dB(A)
Sound Power 79–83 dB(A)

* Measured at 3.1 feet (1 meter) per ISO 3744.

Line Driver coupled to LineLazer Striper (Operating Range)*:

Sound Pressure 99–102 dB(A)
Sound Power 82–86 dB(A)

* Measured at 3.1 feet (1 meter) per ISO 3744.

Graco Phone Number

TO PLACE AN ORDER, contact your Graco distributor, or call this number to identify the distributor closest to you:
1-800-690-2894 Toll Free.

Graco Standard Warranty

Graco warrants all equipment listed in this manual which is manufactured by Graco and bearing its name to be free from defects in material and workmanship on the date of sale to the original purchaser for use. With the exception of any special extended or limited warranty published by Graco, Graco will, for a period of twelve months from the date of sale, repair or replace any part of the equipment determined by Graco to be defective. This warranty applies only when the equipment is installed, operated and maintained in accordance with Graco's written recommendations.

This warranty does not cover, and Graco shall not be liable for general wear and tear, or any malfunction, damage or wear caused by faulty installation, misapplication, abrasion, corrosion, inadequate or improper maintenance, negligence, accident, tampering, or substitution of non-Graco component parts. Nor shall Graco be liable for malfunction, damage or wear caused by the incompatibility of Graco equipment with structures, accessories, equipment or materials not supplied by Graco, or the improper design, manufacture, installation, operation or maintenance of structures, accessories, equipment or materials not supplied by Graco.

This warranty is conditioned upon the prepaid return of the equipment claimed to be defective to an authorized Graco distributor for verification of the claimed defect. If the claimed defect is verified, Graco will repair or replace free of charge any defective parts. The equipment will be returned to the original purchaser transportation prepaid. If inspection of the equipment does not disclose any defect in material or workmanship, repairs will be made at a reasonable charge, which charges may include the costs of parts, labor, and transportation.

Graco's sole obligation and buyer's sole remedy for any breach of warranty shall be as set forth above. The buyer agrees that no other remedy (including, but not limited to, incidental or consequential damages for lost profits, lost sales, injury to person or property, or any other incidental or consequential loss) shall be available. Any action for breach of warranty must be brought within two (2) years of the date of sale.

GRACO MAKES NO WARRANTY, AND DISCLAIMS ALL IMPLIED WARRANTIES OF MERCHANTABILITY AND FITNESS FOR A PARTICULAR PURPOSE IN CONNECTION WITH ACCESSORIES, EQUIPMENT, MATERIALS OR COMPONENTS SOLD BUT NOT MANUFACTURED BY GRACO. These items sold, but not manufactured by Graco (such as electric motors, gas engines, switches, hose, etc.), are subject to the warranty, if any, of their manufacturer. Graco will provide purchaser with reasonable assistance in making any claim for breach of these warranties.

In no event will Graco be liable for indirect, incidental, special or consequential damages resulting from Graco supplying equipment hereunder, or the furnishing, performance, or use of any products or other goods sold hereto, whether due to a breach of contract, breach of warranty, the negligence of Graco, or otherwise.

FOR GRACO CANADA CUSTOMERS

The parties acknowledge that they have required that the present document, as well as all documents, notices and legal proceedings entered into, given or instituted pursuant hereto or relating directly or indirectly hereto, be drawn up in English. Les parties reconnaissent avoir convenu que la rédaction du présente document sera en Anglais, ainsi que tous documents, avis et procédures judiciaires exécutés, donnés ou intentés à la suite de ou en rapport, directement ou indirectement, avec les procédures concernées.

ADDITIONAL WARRANTY COVERAGE

Graco does provide extended warranty and wear warranty for products described in the "Graco Contractor Equipment Warranty Program".

*All written and visual data contained in this document reflects the latest product information available at the time of publication.
Graco reserves the right to make changes at any time without notice.*

This manual contains English. MM 309404

Graco Headquarters: Minneapolis
International Offices: Belgium, China, Japan, Korea

GRACO INC. P.O. BOX 1441 MINNEAPOLIS, MN 55440-1441

www.graco.com

10/2001, Rev 4/2007