

REPAIR



309056

Rev. B



KEEP FOR REFERENCE.
Read this and all related manuals for important warnings and instructions.

INSTRUCTIONS

First choice when quality counts.™

395/455/495st Pro™ Airless Paint Sprayers

3000 psi (210 bar, 21 MPa) Maximum Working Pressure

220–240 VAC

Type	Series	Stand	Lo-boy	Hi-boy
395st Pro™	A	232926 233034		
495st Pro™	A	232946	232947	232948

100–120 VAC

Type	Series	Stand	Lo-boy	Hi-boy
395st Pro™	A	232923 233033		
495st Pro™	A	232943	232944	232945

120 VAC

Type	Series	Stand	Lo-boy	Hi-boy
395st Pro™	A	232920		232922
455st Pro™	A	232930	232931	232932
495st Pro™	A	232940	232941	232942

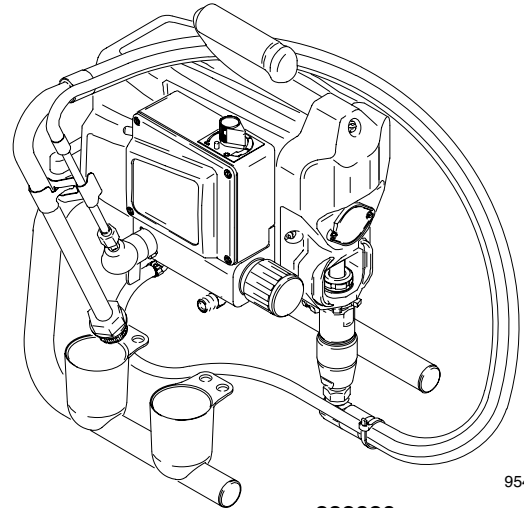

232920

9546A

Related manuals

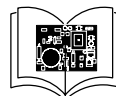

..... 309070



..... 309052



..... 309054



..... 309053



..... 309055



..... 309057

..... 309058



Table of Contents

Component Function and Identification	3	Pressure Control Repair	15
Grounding	5	Drive Housing Replacement	17
Troubleshooting	5	Motor Replacement	18
General Repair Information	4	Displacement Pump Replacement	19
Spin Test	10	Technical Data	20
Motor Brush Replacement	10	Graco Phone Number	20
On/Off Switch Replacement	12	Graco Warranty	20

GRACO INC. P.O. BOX 1441 MINNEAPOLIS, MN 55440-1441

©COPYRIGHT 1999, GRACO INC.

Graco Inc. is registered to I.S. EN ISO 9001

⚠ WARNING

Fire and explosion hazard: Solvent and paint fumes can ignite or explode.

To help prevent a fire and explosion:

- Use only in an extremely well ventilated area.
- Eliminate all ignition sources; such as pilot lights, cigarettes and static arcs from plastic drop cloths. Do not plug or unplug power cords or turn lights on or off in spray area.
- Ground Sprayer, object being sprayed, paint and solvent pails.
- Hold gun firmly to side of grounded pail when triggering into pail.
- Use only conductive airless paint hose.
- Do not use 1,1,1-trichloroethane, methylene chloride, other halogenated hydrocarbon solvents or fluids containing such solvents in pressurized aluminum equipment. Such use could result in a chemical reaction, with the possibility of explosion.



Fluid injection and high pressure hazard: High pressure spray or leaks can inject fluid into the body.

To help prevent injection, always:

- Engage trigger safety latch when not spraying.
- Keep clear of nozzle and leaks.
- Never spray without a tip guard.
- Do **PRESSURE RELIEF** if you stop spraying or begin servicing sprayer.
- Do not use components rated less than sprayer *Maximum Working Pressure*
- Never allow children to use this unit.

If high pressure fluid pierces your skin, the injury might look like "just a cut". But it is a serious wound! Get immediate medical attention.

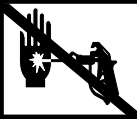

⚠ ADVERTÊNCIA

Poderá ocorrer **incêndio e explosão** quando for pulverizado ou injetado líquido inflamável numa área onde houver má circulação de ar; vapores inflamáveis poderão incendiar-se a partir de uma chama ou faíscas a descoberto.

Para ajudar a evitar incêndio e explosão:

● **Utilize no exterior ou numa área muito bem ventilada.**

- Não utilize 1,1,1-tricloroetano, cloro de metileno, outros solventes de hidrocarbonetos halogenados ou líquidos contendo tais solventes em equipamento de alumínio pressurizado. Tal utilização poderá resultar numa reação química, com possibilidade de explosão.
- Retire, elimine ou desligue todas as fontes de ignição; coloque fita adesiva na tomada da parede. Não fume na área de pulverização.
- Nunca abasteça o depósito de combustível com o motor em funcionamento ou quente.
- Ponha em contato com a terra o pulverizador, o objeto a ser pulverizado, e os baldes de tinta e de solventes.
- Segure a pistola firmemente de encontro ao lado de um balde em contato com a terra, quando estiver descarregando para dentro do mesmo.
- Utilize somente tubos flexíveis condutores para pintura a alta pressão.
- Nunca faça funcionar o motor numa área fechada.

A injeção de líquido é um ferimento grave! Se o líquido a alta pressão penetrar na sua pele, o ferimento poderá parecer "simplesmente um corte". Mas é um ferimento grave! Procure o médico imediatamente.

Para ajudar a evitar injeção de líquido, faça sempre o seguinte:

- Engate o trinco de segurança do gatilho quando não estiver pulverizando.
- Sempre aponte a pistola para longe de você mesmo(a) ou de outras pessoas.
- Alivie a pressão antes de verificar ou reparar qualquer vazamento.
- Alivie a pressão quando desligar o pulverizador ou parar de pulverizar.
- Não utilize componentes classificados para uma pressão nominal inferior à pressão máxima de trabalho dos sistemas.

Nunca permita que crianças utilizem esta unidade. Se sofrer algum ferimento durante a utilização deste equipamento, procure o médico imediatamente.

⚠ MISE EN GARDE

Risque d'incendie et d'explosion imminent pendant la pulvérisation ou le rinçage à pression de fluides inflammables dans une zone à mauvaise circulation d'air et en présence de gaz inflammables pouvant s'allumer par une flamme nue ou des étincelles.

Pour éviter les risques d'incendie et d'explosion:

- **Manipuler les fluides à l'air libre ou dans une zone extrêmement bien aérée.**
- Ne jamais utiliser de trichloroéthane 1,1,1, de chlorure de méthylène, d'autres solvants à base d'hydrocarbures halogénés, ni de produits contenant de tels solvants dans un équipement sous pression en aluminium. Cela pourrait provoquer une réaction chimique avec risque d'explosion.
- Retirer, éteindre ou déboucher toute source d'inflammation, recouvrir tout interrupteur mural avec du ruban adhésif. Ne pas fumer dans la zone de pulvérisation.
- Ne jamais remplir le réservoir d'essence lorsque le moteur est chaud ou en marche.
- Mettre à la terre le pulvérisateur, l'objet à pulvériser ainsi que les seaux de peinture et de solvants.
- Tenir le pistolet fermement contre la paroi d'un seau mis à la terre lorsqu'on pulvérise dans le seau.
- N'utiliser qu'un flexible pour peinture pulvérisée sans air.
- Ne jamais mettre en marche un moteur dans une zone fermée.

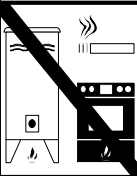

⚠ ADVERTENCIA

Pueden ocurrir **incendios y explosiones** cuando se pulveriza fluido inflamable o cuando se lava con este tipo de fluido en un área donde la circulación de aire es deficiente y los vapores inflamables se pueden encender al contacto con el fuego o chispas.

Para prevenir incendios y explosiones:

● **Use en espacios abiertos o en un área muy bien ventilada.**

- No utilice nunca tricloroetano-1,1,1, cloruro de metileno, u otros disolventes a base de hidrocarburos halógenos o fluidos que contengan tales disolventes en un equipo a presión de aluminio. El uso de estas sustancias puede provocar una intensa reacción química, con riesgos de explosión.
- Retire, apague o desconecte todas las fuentes de ignición; asegure el interruptor de la pared con cinta. No fume en el área de pulverización.
- Nunca llene el estanque de combustible mientras el motor esté en marcha o caliente.
- Ponga a tierra el pulverizador, el objeto que recibe el chorro pulverizado, las cubetas de pintura y disolvente.
- Sostenga firmemente la pistola a un lado de la cubeta puesta a tierra cuando dispare dentro de ella.
- Use solamente mangueras para pintura conductora sin aire.
- Nunca haga andar el motor dentro de un área cerrada.

¡La inyección de fluido en la piel es una lesión seria! Si fluido de alta presión le penetra la piel, la lesión podría parecer "sólo un corte". ¡Es una lesión seria! Consulte de inmediato al médico.

Para prevenir la inyección en la piel, siempre:

- Enganche el seguro del gatillo cuando no use el pulverizador.
- No apunte la pistola ni a sí mismo ni a los demás.
- Alivie la presión antes de inspeccionar o reparar cualquier filtración.
- Alivie la presión cuando apague el pulverizador o deje de usarlo.
- No use componentes cuya capacidad nominal sea inferior a la presión máxima de operación del sistema.

No permita que niños usen esta unidad. Si se lesiona usando este equipo, sométase de inmediato a tratamiento médico.

Component Identification and Function

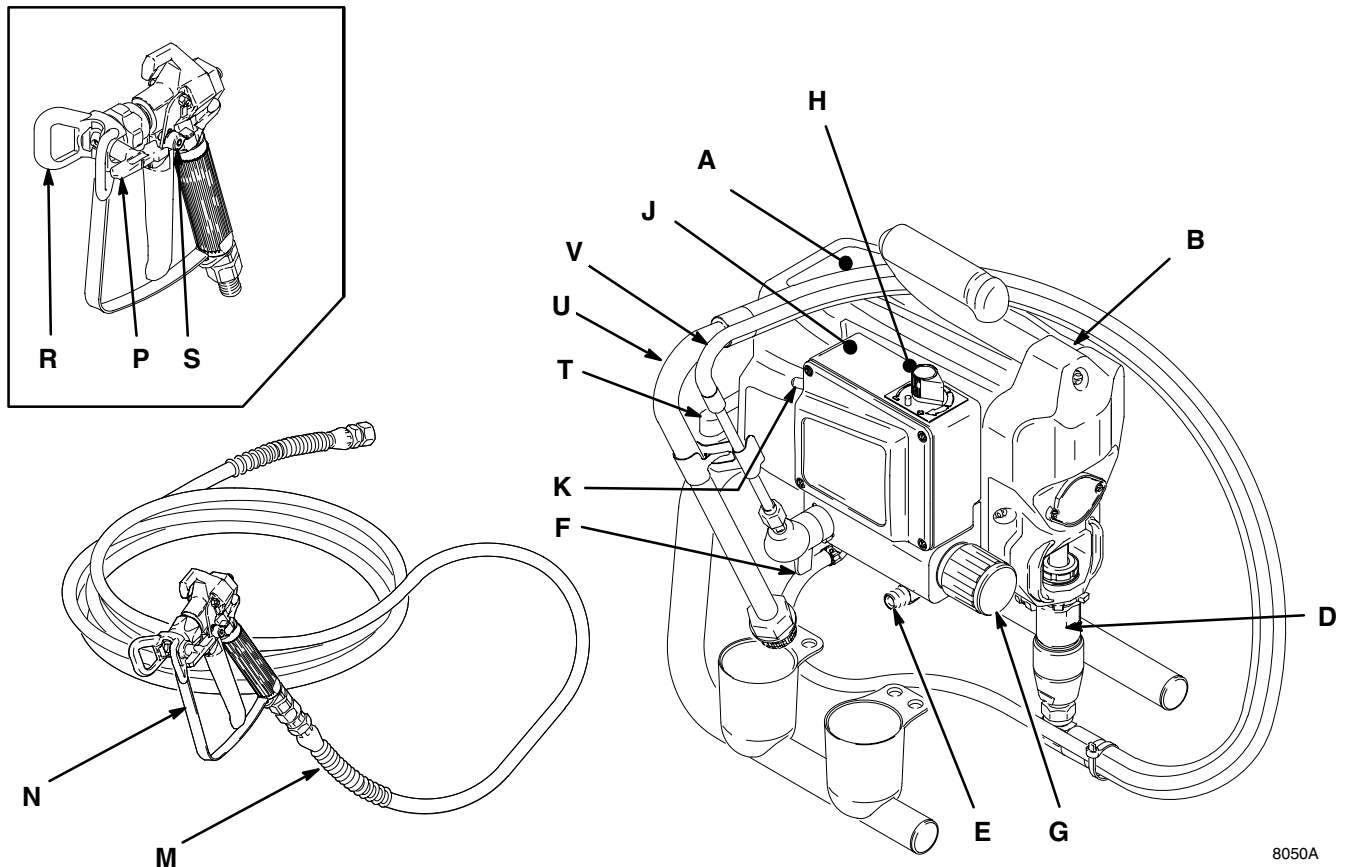

Fig. 1

A	Motor	DC motor, permanent magnet, totally enclosed, fan cooled
B	Drive Assembly	Transfers power from DC motor to displacement pump
D	Displacement Pump	Transfers fluid to be sprayed from source through spray gun
E	Fluid Outlet	Spray gun is connected here
F	Prime Valve	Used to prime and drain sprayer (also relieves fluid outlet pressure) when open
G	Fluid Filter	Final filter of fluid to spray gun
H	Pressure Adjusting Knob	Controls fluid outlet pressure
J	Pressure Control	Controls motor speed to maintain fluid outlet pressure at displacement pump outlet. Works with pressure adjusting knob.
K	ON/OFF Switch	Power switch that controls main power to sprayer
M	50 ft (15 m) Main Hose	1/4 in. ID, grounded, nylon hose with spring guards on both ends
N	Spray Gun	High pressure spray gun with gun safety latch
P	RAC 5 Switch Tip	Uses high pressure fluid to clear tip clogs without removing tip from spray gun
R	HandTite™ Tip Guard	Tip guard reduces risk of injection injury
S	Thumb Lock Safety	Gun safety latch inhibits accidental triggering of spray gun
T	Power Cord Rack	Holds wrapped power cord for storage
U	Suction Hose	Transfers fluid to be sprayed from source to pump
V	Drain Tube	Fluid outlet used to drain and prime the sprayer

General Repair Information

Pressure Relief Procedure

WARNING



INJECTION HAZARD

System pressure must be manually relieved to prevent system from starting or spraying accidentally. Fluid under high pressure can be injected through skin and cause serious injury. To reduce risk of injury from injection, splashing fluid, or moving parts, follow **Pressure Relief Procedure** whenever you:

- are instructed to relieve pressure,
- stop spraying,
- check or service any system equipment,
- or install or clean spray tip.

1. Lock gun safety latch.
2. Turn ON/OFF switch to OFF.
3. Unplug power supply cord.
4. Unlock gun safety latch. Hold metal part of gun firmly to grounded metal pail. Trigger gun to relieve pressure.
5. Lock gun safety latch.
6. Open pressure drain valve. Leave pressure drain valve open until ready to spray again.

If suspected that spray tip or hose is completely clogged, or that pressure has not been fully relieved after following steps above, VERY SLOWLY loosen tip guard retaining nut or hose end coupling to relieve pressure gradually, then loosen completely. Now clear tip or hose obstruction.

CAUTION

To reduce risk of pressure control malfunction:

- Use needle nose pliers to disconnect wire. Never pull on wire, pull on connector.
- Mate wire connectors properly. Center flat blade of insulated male connector in female connector.
- Route wires carefully to avoid interference with other connections of pressure control. Do not pinch wires between cover and control box.

1. **Keep all screws, nuts, washers, gaskets, and electrical fittings** removed during repair procedures. These parts are not normally provided with replacement assemblies.

WARNING



ELECTRIC SHOCK HAZARD MOVING PARTS HAZARD

To reduce risk of serious injury, including electric shock, do not touch moving or electrical parts with fingers or tools while testing repair. Shut off and unplug sprayer when inspection is complete. Install all covers, gaskets, screws and washers before operating sprayer.



2. **Test repair** after problem is corrected.
3. **If sprayer does not operate properly**, review repair procedure to verify procedure was done correctly. If necessary, see Troubleshooting Guide, pages 5 – 9, for other possible solutions.

WARNING



HOT SURFACES HAZARD EXPLOSION HAZARD

Motor and drive housing may be very hot during operation and could burn skin if touched.

Flammable materials spilled on hot, bare motor could cause fire or explosion.

Have motor shroud in place during operation to reduce risk of burns, fire or explosion.



CAUTION

Do not run sprayer dry for more than 30 seconds to avoid damaging pump packings.

4. **Install motor shroud before operation** of sprayer and replace if damaged. Motor shroud directs cooling air around motor to prevent overheating. It can also reduce risk of burns, fire or explosion; see preceding **WARNING**.

Grounding

⚠ WARNING

Improper installation or alteration of grounding plug results in risk of electric shock, fire or explosion that could cause serious injury or death.

1. 220–240 Vac models require a 50 Hz, 10A circuit with a grounding receptacle. 100–120 Vac models require a 50/60 Hz, 15A circuit with a grounding receptacle. See Fig. 2.
2. Do not alter ground prong or use adapter.

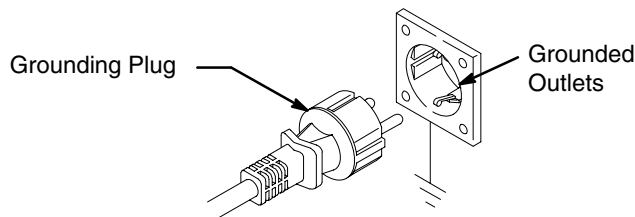

240 Vac model shown

Fig. 2

3. 120 Vac: A 12 AWG, 3 wires with grounding prong, 300 ft (90 m) extension cord may be used.
220–240 Vac: You may use a 3-wire, 1.0 mm (12 AWG) (minimum) extension cord up to 90 m long. Long lengths reduce sprayer performance.

Troubleshooting



Relieve pressure; page 4.

MOTOR WON'T OPERATE

TYPE OF PROBLEM	WHAT TO CHECK <i>If check is OK, go to next check</i>	WHAT TO DO <i>When check is not OK refer to this column</i>
Basic Fluid Pressure Problems	1. Pressure control knob setting. Motor will not run if at minimum setting (fully counterclockwise).	1. Slowly increase pressure setting to see if motor starts.
	2. Spray tip or fluid filter may be clogged.	2. Relieve pressure and clear clog or clean filter; refer to separate gun or tip instruction manual.
Basic Mechanical Problems	1. Pump (13) for frozen or hardened paint.	1. Thaw sprayer if water or water-based paint has frozen in sprayer. Place sprayer in warm area to thaw. Do not start sprayer until thawed completely. If paint hardened (dried) in sprayer, replace pump packings. See page 19 (Displacement Pump Replacement).
	2. Displacement pump connecting rod pin (9a). Pin must be completely pushed into connecting rod (9) and retaining spring (9b) must be firmly in groove of pump pin. See Fig. 12.	2. Push pin into place and secure with spring retainer.
	3. Motor (1). Remove drive housing assembly (10). See page 17. Try to rotate fan by hand.	3. Replace motor (1) if fan won't turn. See page 18.
Basic Electrical Problems	1. Motor control board. Board shuts down and displays error code.	1. See Motor Control Board Diagnostics , page 15.
	2. Electrical supply. Meter must read: 210–255 Vac for 220–240 Vac models. 85–130 Vac for 100–120 Vac models.	2. Reset building circuit breaker; replace building fuse. Try another outlet.
	3. Extension cord. Check extension cord continuity with volt meter.	3. Replace extension cord.
	4. Sprayer power supply cord (79). Inspect for damage such as broken insulation or wires.	4. Replace power supply cord.

Troubleshooting

MOTOR WON'T OPERATE (Continued)

TYPE OF PROBLEM	WHAT TO CHECK <i>If check is OK, go to next check</i>	WHAT TO DO <i>When check is not OK refer to this column</i>
Basic Electrical Problems (continued)	1. That motor leads are securely fastened and properly mated.	1. Replace loose terminals; crimp to leads. Be sure terminals are firmly connected. Clean circuit board terminals. Securely reconnect leads.
	2. For loose motor brush lead connections and terminals. See page 10.	2. Tighten terminal screws. Replace brushes if leads are damaged. See page 10.
	3. Brush length which must be 1/2 in. minimum. See page 10. NOTE: Brushes do not wear at the same rate on both sides of motor. Check both brushes.	3. Replace brushes. See page 10.
	4. For broken or misaligned motor brush springs. Rolled portion of spring must rest squarely on top of brush. See page 10.	4. Replace spring if broken. Realign spring with brush. See page 10.
	5. Motor brushes may be binding in brush holders. See page 10.	5. Clean brush holders. Remove carbon with small cleaning brush. Align brush leads with slot in brush holder to assure free vertical brush movement.
	6. Motor armature commutator for burn spots, gouges and extreme roughness. See page 10.	6. Remove motor and have motor shop resurface commutator if possible. See page 18.
	7. Motor armature for shorts using armature tester (growler) or perform spin test. See page 10.	7. Replace motor. See page 18.
Refer to wiring diagram on page 12, 13 or 14 to identify test points (TP).	1. Power supply cord (79). Connect volt meter between TP1 (neutral) and TP2 (L2, 120 Vac). Plug in sprayer. Meter must read: 210–255 Vac for 220–240 Vac models. 85–130 Vac for 100–120 Vac models. Unplug sprayer.	1. Replace power supply cord.
	2. ON/OFF switch (23). Connect volt meter between L1 and L2 terminal on ON/OFF switch. Plug in sprayer and turn ON. Meter must read: 210–255 Vac for 220–240 Vac models. 85–130 Vac for 100–120 Vac models.	2. Replace ON/OFF switch. See page 12.
	3. Motor thermal cutoff switch. Turn sprayer OFF. Check for continuity between TO1 and TO2 with ohmmeter.	3. If thermal switch is open (no continuity), allow motor to cool. If switch remains open after motor cools, replace motor. If thermal switch closes after motor cools, correct cause of overheating.
	4. All terminals for damage or loose fit.	4. Replace damaged terminals and reconnect securely.

Troubleshooting

LOW OR FLUCTUATING OUTPUT

TYPE OF PROBLEM	WHAT TO CHECK <i>If check is OK, go to next check</i>	WHAT TO DO <i>When check is not OK refer to this column</i>
Low Output	1. For worn spray tip.	1. Follow Pressure Relief Procedure Warning , then replace tip. See your separate gun or tip manual.
	2. Verify pump does not continue to stroke when gun trigger is released.	2. Service pump. See page 19.
	3. Filter clogged.	3. Relieve pressure. Check and clean filter.
	4. Prime valve leaking.	4. Relieve pressure. Repair prime valve.
	5. Suction hose connections.	5. Tighten any loose connections.
	6. Electrical supply with volt meter. Meter must read: 210–255 Vac for 220–240 Vac models. 85–130 Vac for 100–120 Vac models. Low volt-ages reduce sprayer performance.	6. Reset building circuit breaker; replace building fuse. Repair electrical outlet or try another outlet.
	7. Extension cord size and length; must be at least 12 gauge wire and no longer than 300 ft. Longer cord lengths reduce sprayer performance.	7. Replace with a correct, grounded extension cord.
	8. Leads from motor to pressure control circuit board (35) for damaged or loose wires or connectors. Inspect wiring insulation and terminals for signs of overheating.	8. Be sure male terminal blades are centered and firmly connected to female terminals. Replace any loose terminal or damaged wiring. Securely reconnect terminals.
	9. For loose motor brush leads and terminals. See page 10.	9. Tighten terminal screws. Replace brushes if leads are damaged. See page 10.
	10. For worn motor brushes which must be 1/2 in. minimum. See page 10.	10. Replace brushes. See page 10.
	11. For broken and misaligned motor brush springs. Rolled portion of spring must rest squarely on top of brush.	11. Replace spring if broken. Realign spring with brush. See page 10.
	12. Motor brushes for binding in brush holders. See page 10.	12. Clean brush holders, remove carbon dust with small cleaning brush. Align brush lead with slot in brush holder to assure free vertical brush movement.
	13. Low stall pressure.	13. Do either or both: a. Turn pressure control knob fully clockwise. Make sure pressure control knob is properly installed to allow full clockwise position. b. Try a new transducer.
	14. Motor armature for shorts by using an armature tester (growler) or perform spin test. See page 10.	14. Replace motor. See page 18.

Troubleshooting

LOW OR FLUCTUATING OUTPUT

TYPE OF PROBLEM	WHAT TO CHECK <i>If check is OK, go to next check</i>	WHAT TO DO <i>When check is not OK refer to this column</i>
Motor runs and pump strokes	1. Paint supply.	1. Refill and reprime pump.
	2. Intake strainer clogged.	2. Remove and clean, then reinstall.
	3. Suction tube or fittings loose.	3. Tighten; use thread sealant or sealing tape on threads if necessary.
	4. To see if intake valve ball and piston ball are seating properly. See page 19.	4. Remove intake valve and clean. Check balls and seats for nicks; replace if necessary, page 19. Strain paint before using to remove particles that could clog pump.
	5. Leaking around throat packing nut which may indicate worn or damaged packings. See page 19.	5. Replace packings, page 19. Also check piston valve seat for hardened paint or nicks and replace if necessary. Tighten packing nut/wet-cup.
	6. Pump rod damage.	6. Repair pump, page 19.
Motor runs but pump does not stroke	1. Displacement pump pin (9a) (damaged or missing), page 19.	1. Replace pump pin if missing. Be sure retainer spring (9b) is fully in groove all around connecting rod, page 19.
	2. Connecting rod assembly (9) for damage, page 17.	2. Replace connecting rod assembly, page 17.
	3. Gears or drive housing, page 17.	3. Inspect drive housing assembly and gears for damage and replace if necessary, page 17.

Troubleshooting

MOTOR IS HOT AND RUNS INTERMITTENTLY

TYPE OF PROBLEM	WHAT TO CHECK <i>If check is OK, go to next check</i>	WHAT TO DO <i>When check is not OK refer to this column</i>
Motor is hot and runs intermittently.	1. Determine if sprayer was operated at high pressure with small tips, which causes low motor RPM and excessive heat build up.	1. Decrease pressure setting or increase tip size.
	2. Be sure ambient temperature where sprayer is located is no more than 90°F and sprayer is not located in direct sun.	2. Move sprayer to shaded, cooler area if possible.

ELECTRICAL SHORT

TYPE OF PROBLEM	WHAT TO CHECK <i>If check is OK, go to next check</i>	WHAT TO DO <i>When check is not OK refer to this column</i>
<p>Building circuit breaker opens as soon as sprayer switch is turned on.</p> <p style="text-align: center;">CAUTION</p> <p>Any short in any part of the motor power circuit will cause the control circuit to inhibit sprayer operation. Correctly diagnose and repair all shorts before checking and replacing control board.</p>	1. All electrical wiring for damaged insulation, and all terminals for loose fit or damage. Also wires between pressure control and motor. See page 18.	1. Repair or replace any damaged wiring or terminals. Securely reconnect all wires.
	2. For missing inspection plate gasket (see page 18), bent terminal forks or other metal to metal contact points which could cause a short.	2. Correct faulty conditions.
	3. Motor armature for shorts. Use an armature tester (growler) or perform spin test. See page 10. Inspect windings for burns.	3. Replace motor. See page 18.
	4. Motor control board (35) by performing motor control board diagnostics on page 15. If diagnostics indicate, substitute with a good board. CAUTION: Do not perform this check until motor armature is determined to be good. A bad motor armature can burn out a good board.	4. Replace with a new pressure control board (35). See page 15.
Building circuit breaker opens as soon as sprayer is plugged into outlet and sprayer is NOT turned on.	1. Basic Electrical Problems on page 5.	1. Perform necessary procedures.
	2. ON/OFF switch (23) See page 12. <i>Be sure sprayer is unplugged!</i> Disconnect wires from switch. Check switch with ohmmeter. Reading must be infinity with ON/OFF switch OFF, and zero with switch ON.	2. Replace ON/OFF switch. See page 12.
	3. For damaged or pinched wires in pressure control. See page 15.	3. Replace damaged parts. See page 15.
Sprayer quits after sprayer operates for 5 to 10 minutes.	1. Basic Electrical Problems on page 5.	1. Perform necessary procedures.
	2. Electrical supply with volt meter. Meter must read: 210–255 Vac for 220–240 Vac models. 85–130 Vac for 100–120 Vac models.	2. If voltage is too high, do not operate sprayer until corrected.
	3. Tightness of pump packing nut. Over tightening tightens packings on rod, restricts pump action, and damages packings.	3. Loosen packing nut. Check for leaking around throat. Replace pump packings, if necessary. See page 19.

Spin Test

Setup



Electric Shock Hazard; page 4.

To check armature, motor winding and brush electrical continuity:

1.  Relieve pressure; page 4.

2. Remove drive housing; page 17.
3. Fig. 3. Remove pressure control cover (39). Disconnect motor leads (F) and (G).
4. Fig. 4. Remove motor shroud (74) and inspection covers (A).

Armature Short Circuit Test

Quickly turn motor fan by hand. If no electrical shorts, motor coasts two or three revolutions before complete stop. If motor does not spin freely, armature is shorted. Replace motor; page 18.

Armature, Brushes, and Motor Wiring Open Circuit Test (Continuity)

1. Connect red and black motor leads together with test lead. Turn motor fan by hand at about two revolutions per second.
2. If uneven or no resistance, check for: broken brush springs, brush leads, motor leads; loose brush terminal screws, motor lead terminals; worn brushes. Repair as needed; page 10.
3. If still uneven or no resistance, replace motor; page 18.

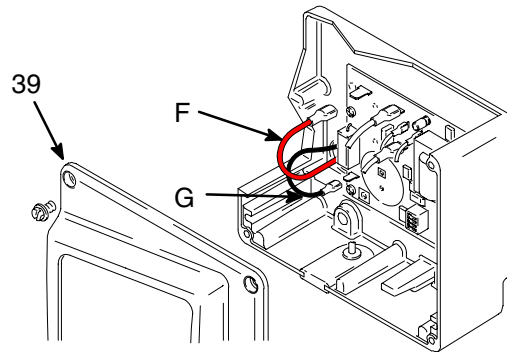

Fig. 3

9578A

Motor Brush Replacement

Motor Brush Removal

Replace brushes worn to less than 1/2 in. Brushes wear differently on each side of motor, check both sides. Brush Repair Kit 236967 is available. Spring clip, 112766, may be purchased separately.

1. Read **General Repair Information;** page 4.

2.  Relieve pressure; page 4.

3. Fig. 4. Remove motor shroud (74) and two inspection covers (A).

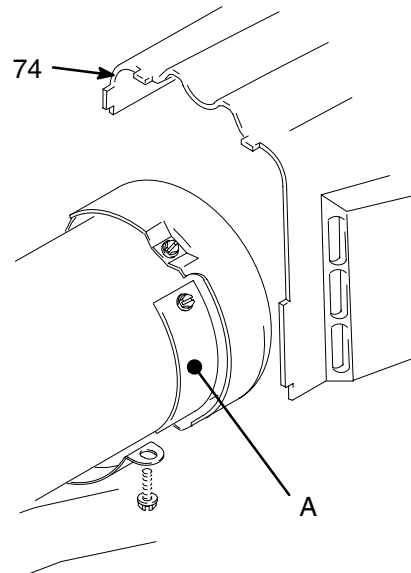

Fig. 4

7703B

(Continued on page 11)

Motor Brush Replacement

4. Fig. 5. Push in spring clip (A) to release hook (B) from brush holder (C). Pull out spring clip (A).
5. Fig. 5. Pull brush lead (D) out of terminal (E). Remove brush (F).

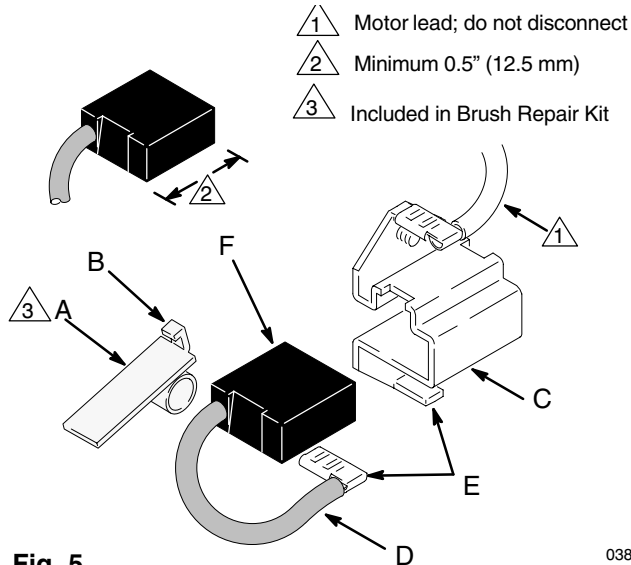

Fig. 5

03881

6. Inspect commutator for excessive pitting, burning or gouging. A black color on commutator is normal. Have commutator resurfaced by a motor repair shop if brushes wear too fast.

Motor Brush Installation

⚠ CAUTION

When installing brushes, follow all steps carefully to avoid damaging parts.

1. Fig. 6. Install new brush (F) with lead into brush holder (C).
2. Fig. 5. Slide brush lead (D) into terminal (E).
3. Fig. 6. Install spring clip (A). Push down to set hook (B) into brush holder (C).

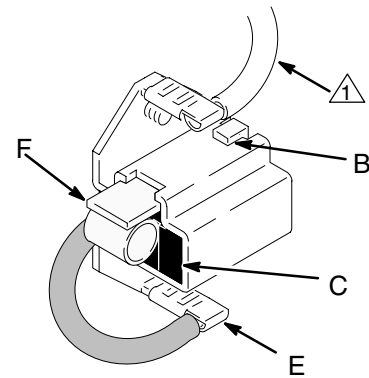

Fig. 6

03881

4. Repeat for other side.
5. Test brushes.
 - a. Remove pump (13); **Displacement Pump Replacement**, page 19.
 - b. With sprayer OFF, turn pressure control knob fully counterclockwise to minimum pressure. Plug in sprayer.
 - c. Turn sprayer ON. Slowly increase pressure until motor is at full speed.

⚠ CAUTION

Do not run sprayer dry for more than 30 seconds while checking brushes to avoid damaging displacement pump packings.

6. Install brush inspection covers and gaskets.
7. Break in brushes.
 - a. Operate sprayer 1 hour with no load.
 - b. Install pump (13); **Displacement Pump Replacement**, page 19.

On/Off Switch Replacement

120 Vac (232920, 232922, 232930 – 232932, 232940 – 232942)

Removal

1.  Relieve pressure; page 4.
2. Fig. 7. Remove four screws (18) and pressure control cover (39).
3. Disconnect two wires (A) from ON/OFF switch (23).
4. Remove toggle boot (25) and locking ring (24). Remove ON/OFF switch (23).

Installation

1. Install new ON/OFF switch (23). Install locking ring (24) and toggle boot (25).
2. Connect two wires (A) to ON/OFF switch.
3. Install pressure control cover (39) with four screws (18).

120 Vac

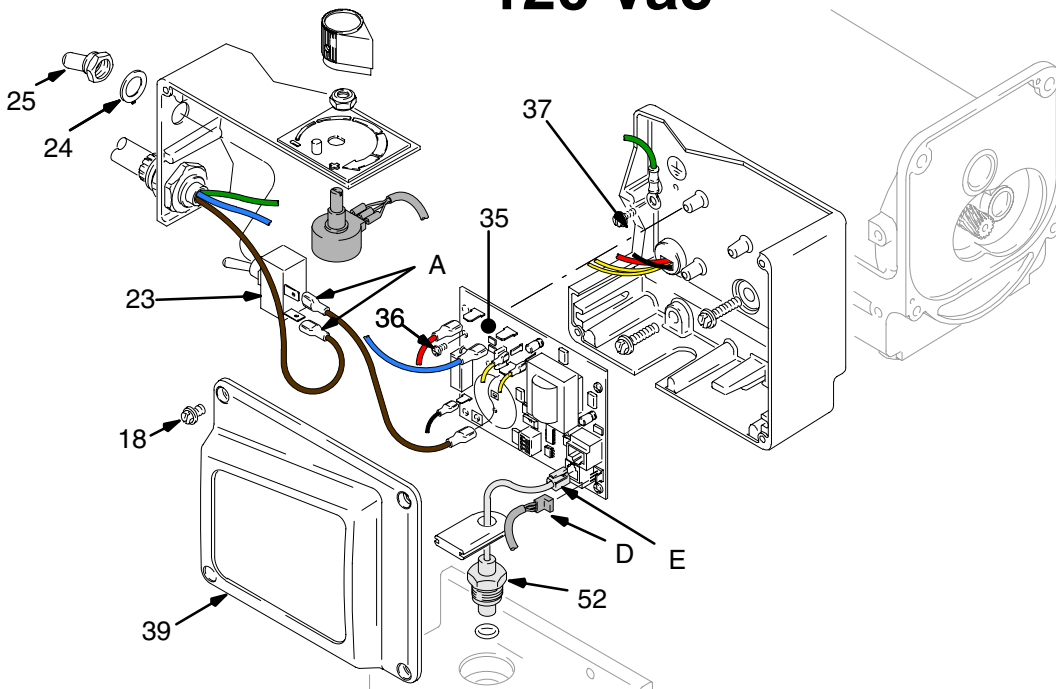

Wiring Diagram

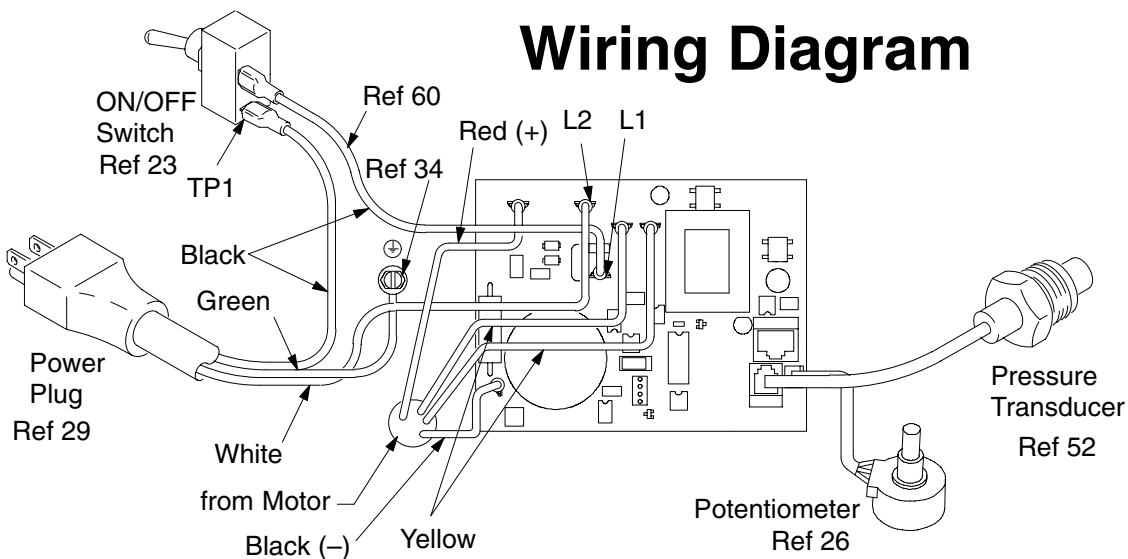

9580A

Fig. 7

On/Off Switch Replacement

100 Vac (232923, 232943 – 232945, 233033)

Removal

1.  Relieve pressure; page 4.
2. Fig. 8. Remove four screws (18) and pressure control cover (39).
3. Remove display connector (B) from plug (C)
4. Disconnect four wires (A) from ON/OFF switch (23).
5. Remove toggle boot (25) and locking ring (24). Remove ON/OFF switch (23).

Installation

1. Install new ON/OFF switch (23). Install locking ring (24) and toggle boot (25).
2. Connect four wires (A) to ON/OFF switch (23).
3. Install display connector (B) in plug (C)
4. Install pressure control cover (39) with four screws (18).

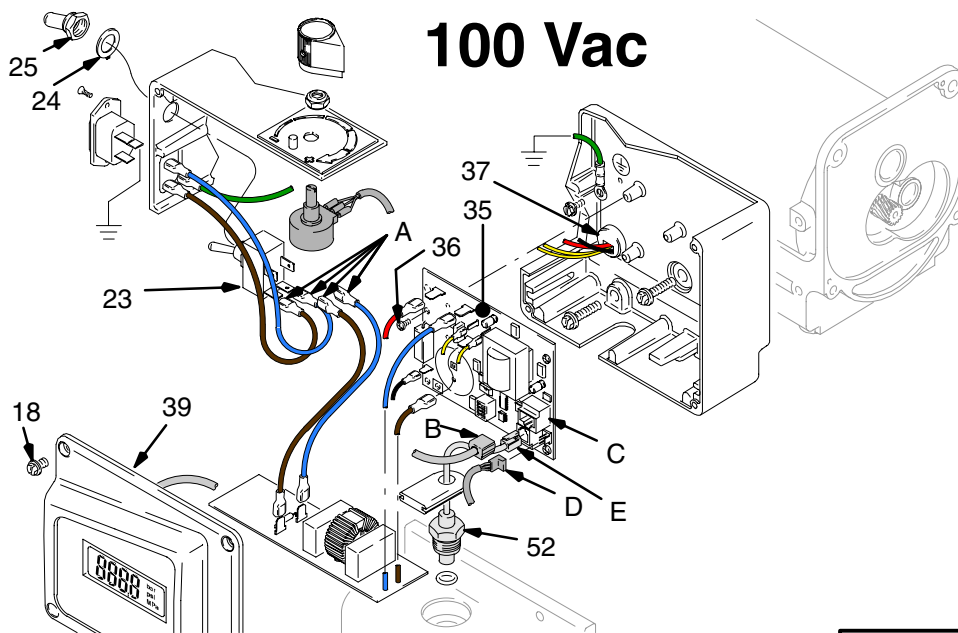

Wiring Diagram

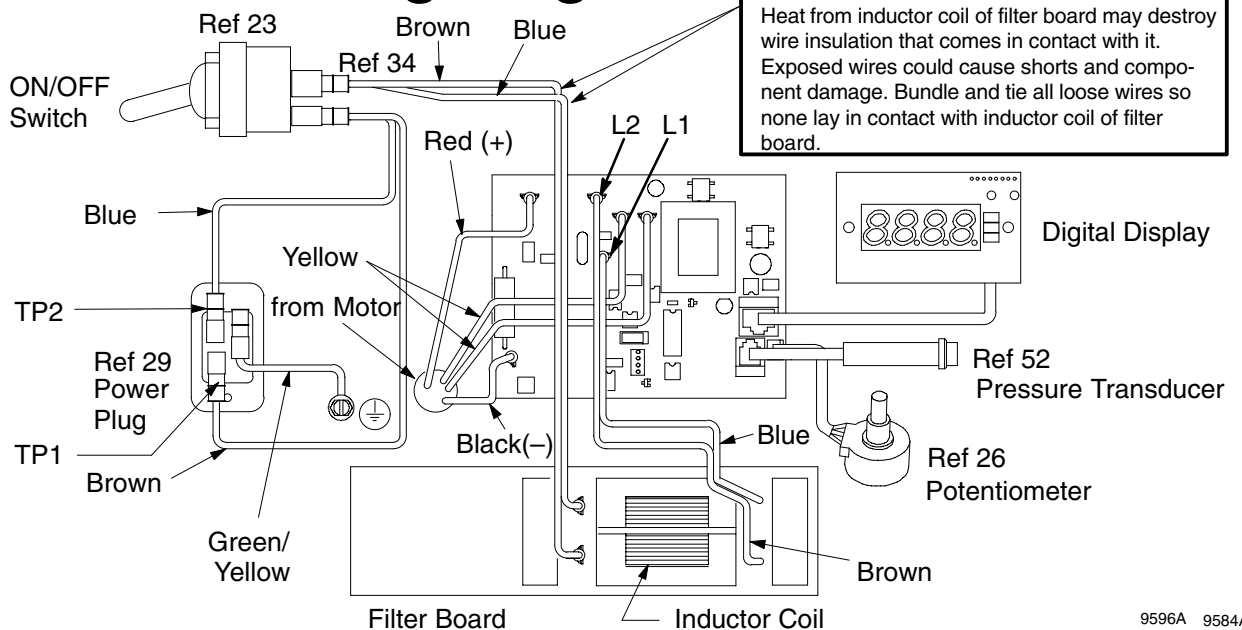

CAUTION
Heat from inductor coil of filter board may destroy wire insulation that comes in contact with it. Exposed wires could cause shorts and component damage. Bundle and tie all loose wires so none lay in contact with inductor coil of filter board.

Fig. 8

9596A 9584A

On/Off Switch Replacement

240 Vac (232926, 232946 – 232948, 233034)

Removal

1.  Relieve pressure; page 4.
2. Fig. 9. Remove pressure control cover (39).
3. Remove display connector (B) from plug (C)
4. Disconnect four wires (A) at ON/OFF switch (23).
5. Remove toggle boot (25) and locking ring (24). Remove ON/OFF switch (23).

Installation

1. Install new ON/OFF switch (23). Install locking ring (24) and toggle boot (25).
2. Connect four wires (A) to ON/OFF switch.
3. Install display connector (B) in plug (C)
4. Install pressure control cover (39).

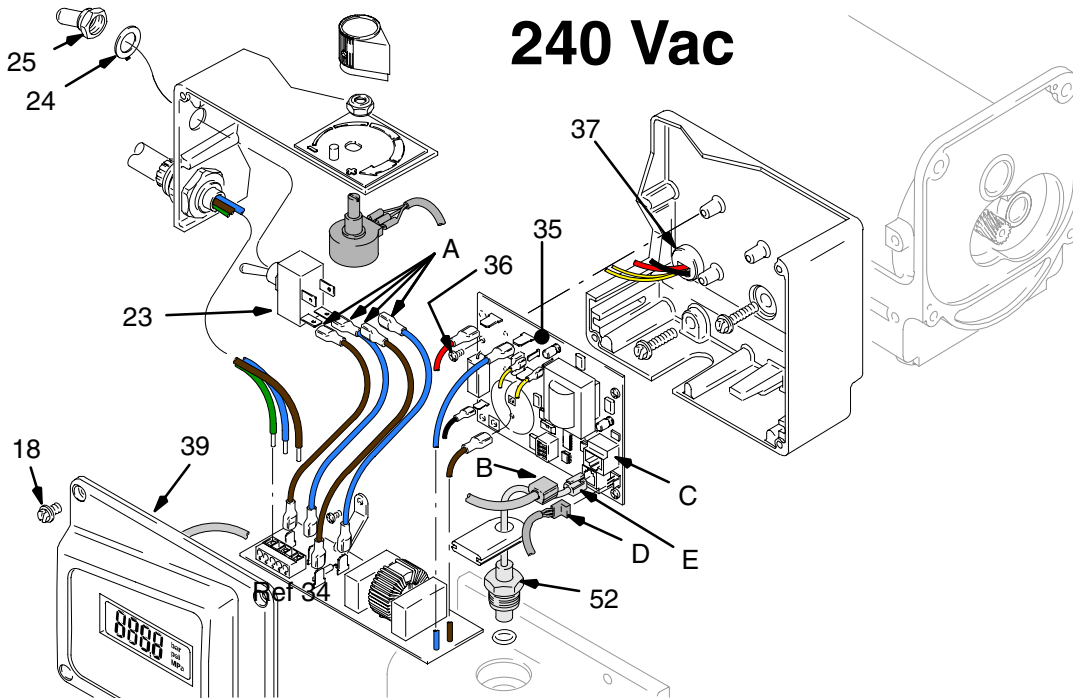

Wiring Diagram

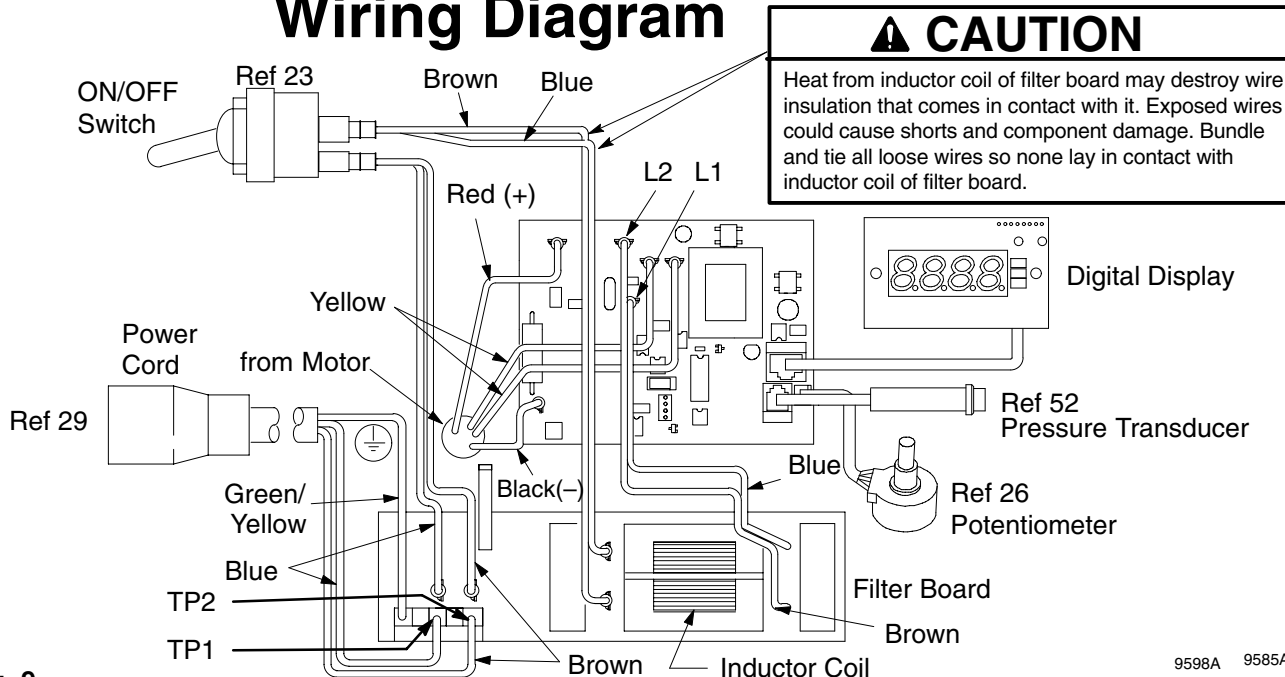

Fig. 9

9598A 9585A

Pressure Control Repair

Motor Control Board

Removal

Refer to Fig. 7, 8 or 9 depending on sprayer voltage.

-  Relieve pressure; page 4.
- Remove four screws (18) and cover (39).
- Disconnect at motor control board (35):
 - Filter board (X) (not 120 Vac sprayers).
 - Four motor leads: two yellow, black (+) and red (-).
 - Lead (D) from potentiometer.
 - Lead (E) from transducer.
 - Lead (B) from display (not 120 Vac sprayers).
- Remove five screws (36) and circuit board (35).

Installation

- Clean pad on rear of motor control board. Apply small amount of thermal compound 073019 to pad.
- Fig. 7. Install motor control board (35) with five screws (36).
- Connect to motor control board (35):
 - Lead (E) to transducer.
 - Lead (D) to potentiometer.
 - Four motor leads: two yellow, black (+) and red (-).
 - Filter board (X) (not 120 Vac sprayers).
 - Lead (B) to display (not 120 Vac sprayers).
- Bundle and tie all loose wires so none lay in contact with inductor coil on filter board (not 120 Vac sprayers). See **Wiring Diagram CAUTION**, Fig. 8 or 9.
- Install cover (39) with four screws (18).

Motor Control Board Diagnostics

Note: Keep a new transducer on hand to use for test.

 CAUTION
<p>Do not allow sprayer to develop fluid pressure without transducer installed. Leave drain valve open if test transducer is used.</p>

- For sprayers with digital display, see **Digital Display Messages**, page 16.

- Remove four screws (18) and cover (39). See Fig. 7.
- Turn ON/OFF switch ON.
- Observe LED operation and reference following table:

-  Relieve pressure and unplug sprayer before servicing control board; page 4.

LED BLINKS	SPRAYER OPERATION	INDICATES	WHAT TO DO
Once	Sprayer runs	Normal operation	Do nothing
Two times repeatedly	Sprayer shuts down and LED continues to blink two times repeatedly	Run away pressure. Pressure greater than 4500 psi (310 bar, 31 MPa).	Replace motor control board. See preceding Motor control board removal procedure.
Three times repeatedly	Sprayer shuts down and LED continues to blink three times repeatedly	Pressure transducer is faulty or missing	Check transducer connection. Open drain valve. Substitute new transducer for transducer in sprayer. If sprayer runs, replace transducer.
Four times repeatedly	Sprayer shuts down and LED continues to blink four times repeatedly	Line voltage is too high	Check for voltage supply problems
Five times repeatedly	Sprayer shuts down and LED continues to blink five times repeatedly	Too much current	Check for locked rotor, shorted wiring or motor. Repair or replace failed parts.

Pressure Control Repair

Digital Display Messages



No display does not mean that sprayer is not pressurized. Relieve pressure before repair; page 4.

DISPLAY	SPRAYER OPERATION	INDICATION	ACTION
No Display	Sprayer stops. Power is not applied. Sprayer may be pressurized.	Loss of power	Check power source. Relieve pressure before repair or disassembly.
3000 psi 210 bar 21 MPa	Sprayer is pressurized. Power is applied. (Pressure varies with tip size and pressure control setting.)	Normal operation	Spray
E:02	Sprayer may continue to run. Power is applied.	Pressure greater than 4500 psi (310 bar, 31 MPa)	Replace pressure control board
E:03	Sprayer stops. Power is applied.	Pressure transducer faulty, bad connection or broken wire.	Check transducer connection. Open drain valve. Substitute new transducer for transducer in sprayer. If sprayer runs, replace transducer.
E:04	Sprayer stops. Power is applied.	Line voltage too high	Check for voltage supply problem
E:05	Sprayer stops. Power is applied.	Too much current	Check for locked rotor, shorted wiring or motor. Repair or replace failed parts.
----	Power is applied.	Pressure less than 200 psi (14 bar, 1.4 MPa)	Increase pressure if desired. Drain valve may be open

Pressure Control Transducer

Removal

Refer to Fig. 7, 8 or 9 depending on sprayer voltage.

1. Relieve pressure; page 4.
2. Remove four screws (18) and cover (39).
3. Disconnect lead (E) from motor control board (35).
4. Remove two screws (22) and filter housing (45).
5. Thread transducer lead plastic connector down through transducer grommet (28).
6. Remove pressure control transducer (52) and packing o-ring (51) from filter housing.

Installation

1. Install packing o-ring (51) and pressure control transducer (52) in filter housing (45). Torque to 30–35 ft-lb.
2. Thread transducer lead plastic connector up through transducer grommet (28).
3. Install filter housing (45) with two screws (22).

4. Connect lead (E) to motor control board (35).
5. Install cover (39) with four screws (18).

Pressure Adjust Potentiometer

Removal

Refer to Fig. 7, 8 or 9 depending on sprayer voltage.

1. Relieve pressure; page 4.
2. Remove four screws (18) and cover (39).
3. Disconnect all leads from motor control board (35).
4. Remove five screws (36) and board (35)
5. Remove potentiometer knob (27), sealing shaft nut (33) and pressure adjust potentiometer (26).

Installation



1. Install pressure adjust potentiometer (26), sealing shaft nut (33) and potentiometer knob (27).
 - a. Turn potentiometer fully clockwise.
 - b. Install knob at full clockwise position.
2. Install board (35) with five screws (36).
3. Connect all leads to motor control board (35).
4. Install cover (39) with four screws (18).

Drive Housing Replacement

CAUTION

Do not drop gear cluster (7) when removing drive housing (10). Gear cluster may stay engaged in motor front end bell or drive housing.

Disassembly

-   Relieve pressure; page 4.
- Remove pump (13); **Displacement Pump Replacement**, page 19.
- Fig. 10. Tip sprayer up. Remove screw (74c) and remove shroud (74).
- Remove two front screws (22).

- Remove two back screws (22).
- Pull drive housing (10) off of motor (1).

Assembly

- Push drive housing (10) onto motor (1)
- Install two front screws (22).
- Install two back screws (22).
- Fig. 10. Tip sprayer up. Install shroud (74) with screw (74c).
- Install pump (13); **Displacement Pump Replacement**, page 19.
- Install new access cover (10a) with two screws (10b).

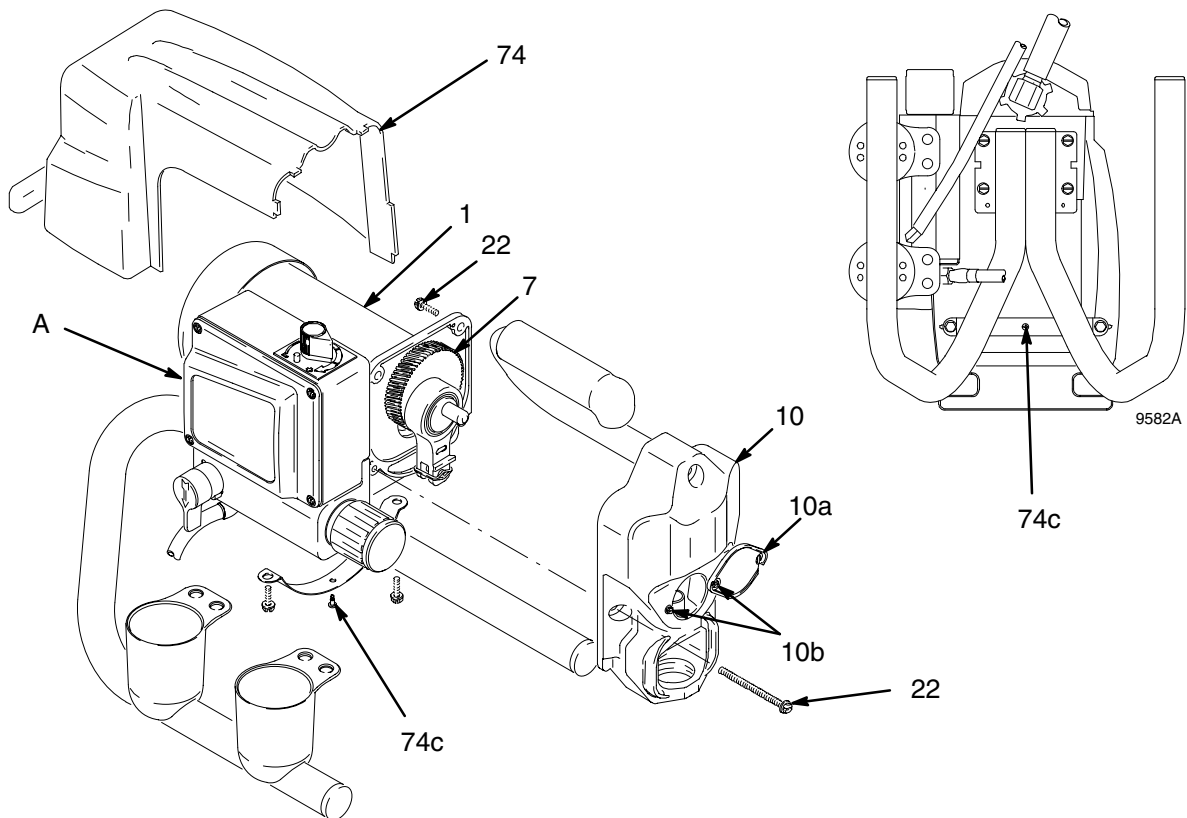

Fig. 10

Motor Replacement

Disassembly

1.  Relieve pressure; page 4.
2. Remove pump (13); **Displacement Pump Replacement**, page 19.

CAUTION

Do not drop gear cluster (7) when removing drive housing (10). Gear cluster may stay engaged in motor front end bell or drive housing.

3. Remove drive housing (10); **Drive Housing Replacement**, page 17.
4. Remove four screws (18) and cover (39).
5. Disconnect all leads from board (35). Remove five screws (36) and board.
6. Remove strain relief (37, page 12, 13, 14).
7. Remove three screws (22) behind board and remove control housing (21).
8. Remove four screws (22) and motor (1) from frame (63).

Assembly

1. Install new motor (1) on frame (63) with four screws (22).
2. Install control housing (21) with three screws (22).
3. Install strain relief (37, page 12, 13, 14).
4. Install board (35) with five screws (36). Connect all leads to board (35).
5. Install drive housing (10); **Drive Housing Replacement**, page 17.
6. Install pump (13); **Displacement Pump Replacement**, page 19.

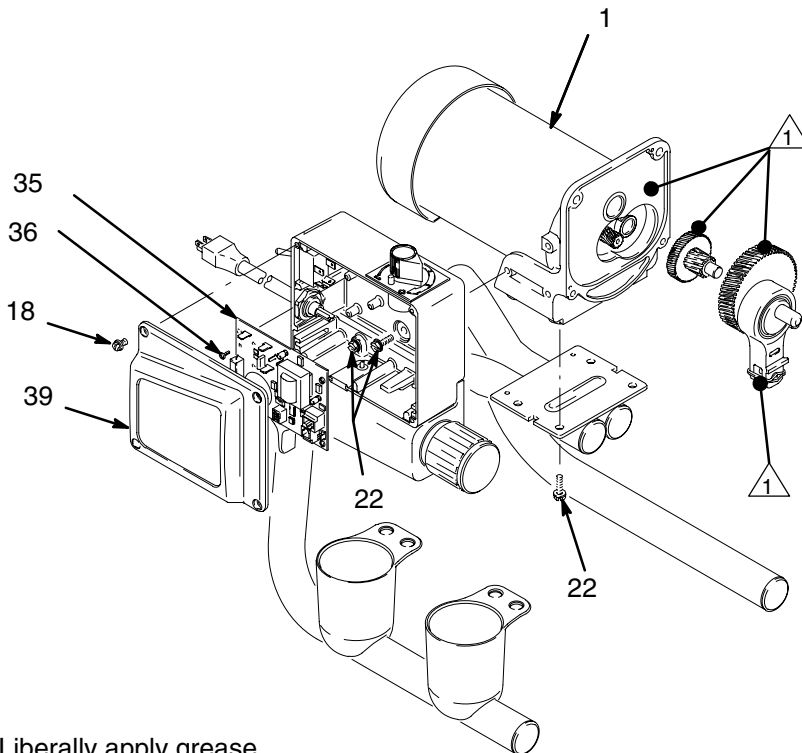

 Liberally apply grease

Fig. 11

7699B

Displacement Pump Replacement

See manual 309053 for pump repair instructions.

See manual 309057 or 309058 for sprayer part number references.

Removal

1. Flush pump (13).

2.  Relieve pressure; page 4.

3. Fig. 12. Loosen two screws (10b) and rotate cover (10a).

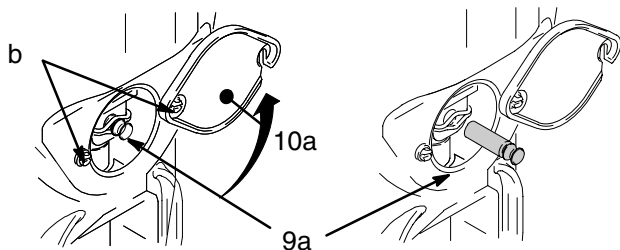

g. 12 9573A

4. Cycle pump until pump pin (9a) is in position to be removed. Remove pump pin (9a).

5. Fig. 13. Remove suction tube (78) and hose (19).

6. Loosen pump jam nut (12). Unscrew pump.

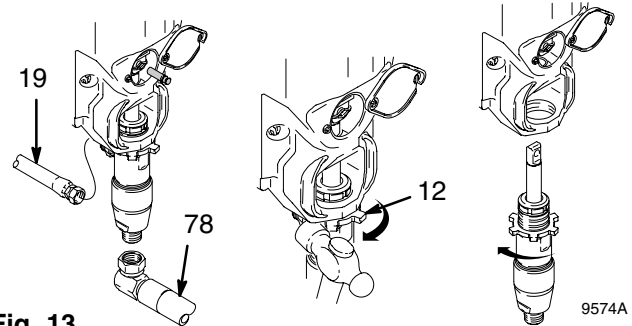

Fig. 13 9574A

Installation

WARNING

If pin works loose, parts could break off due to force of pumping action. Parts could project through the air and result in serious injury or property damage.

CAUTION

If the pump locknut loosens during operation, the threads of the drive housing will be damaged.

1. Fig. 14. Extend pump piston rod fully. Apply grease to top of pump rod at (A) or inside connecting rod.

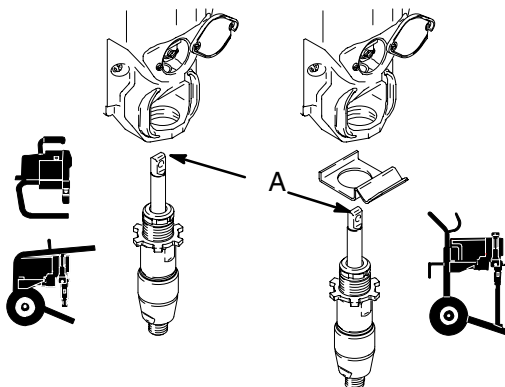

Fig. 14 9575A

3. Push pump up until pump threads engage.

4. Screw in pump until threads are flush with drive housing opening. Align pump outlet to back.

5. Fig. 13. Install suction tube (78) and hose (19).

6. Fig. 15. Screw jam nut (12) up onto pump until nut stops. Tighten jam nut by hand, then tap 1/8 to 1/4 turn with a 20 oz (maximum) hammer to approximately 75 \square 5 ft-lb (102 N·m).

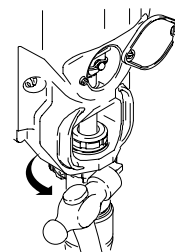

Fig. 15 9576A

7. Fig. 16. Fill packing nut with Graco TSL until fluid flows onto top of seal.

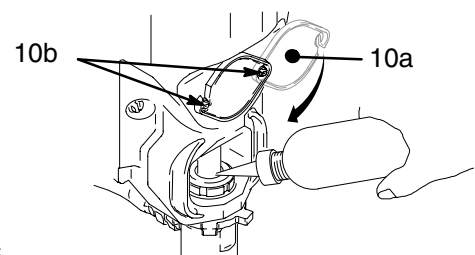

Fig. 16 9577A

2. Fig. 12. Install pump pin (9a). Verify retainer spring (9b) is in groove of pump pin.

8. Fig. 12. rotate cover (10a); tighten screws (10b).

Technical Data

st Pro Model	100–120V, Ø, A, Hz	220–240V, Ø, A, Hz	Generator Minimum W	Motor HP (W)	Cycles per gallon (liter)	Maximum Delivery gpm (lpm)	Maximum Tip size	Fluid Outlet npsm
395	1, 15, 50/60	1, 10, 50/60	3000	1/2 (373)	680 (180)	0.38 (1.25)	0.019	1/4 in.
455	1, 15, 50/60	1, 10, 50/60	3400	5/8 (466)	680 (180)	0.46 (1.74)	0.021	1/4 in.
495	1, 15, 50/60	1, 10, 50/60	3750	3/4 (560)	680 (180)	0.54 (2.09)	0.023	1/4 in.

Basic Sprayer Wetted Parts:
 zinc-plated carbon steel, polyurethane, polyethylene,
 stainless steel, PTFE®, Delrin®, chrome plating,
 leather, V-Max™ UHMWPE, aluminum, stainless
 steel, tungsten carbide

NOTE: Delrin® and PTFE®

Dimensions

Model	Weight lb (kg)			Height in. (cm)	Length in. (cm)	Width in. (cm)
	395	455	495			
Stand	39 (18)	41 (19)	43 (20)	21 (53.3)	15 (38.1)	14 (35.6)
Lo-Boy	N/A	59 (27)	61 (28)	21 (53.3)	26 (66.0)	20.5 (52.1)
Hi-Boy	57 (26)	59 (27)	66 (30)	29.5 (74.9) Handle down, 39.5 (100.3) Handle up	21 (53.3)	20.5 (52.1)

Graco Phone Number

TO PLACE AN ORDER OR FOR SERVICE, contact your Graco distributor,
 or call 1–800–690–2894 to identify the nearest distributor.

*All written and visual data contained in this document reflects the latest product information available at the time of publication.
 Graco reserves the right to make changes at any time without notice.*

Sales Offices: Minneapolis, Detroit
International Offices: Belgium, Korea, Hong Kong, Japan

www.graco.com

PRINTED IN USA 309056 December 1999, Revised 12/2001