 This manual contains important warnings and information.
READ AND KEEP FOR REFERENCE.

INSTRUCTIONS

First choice when quality counts.™

ULTRA® MAX 695 Airless Paint Sprayer

3000 psi (210 bar, 21 MPa) Maximum Working Pressure

230 VAC 

Model 232138, Series A

Complete Hi-boy sprayer with hoses, gun, RAC IV® DripLess™ Tip Guard and SwitchTip™

Model 232135, Series A

Complete Lo-boy sprayer with hoses, gun, RAC IV® DripLess™ Tip Guard and SwitchTip™

100 VAC

Model 232136, Series A

Basic Hi-boy sprayer

Model 232137, Series A

Basic Lo-boy sprayer

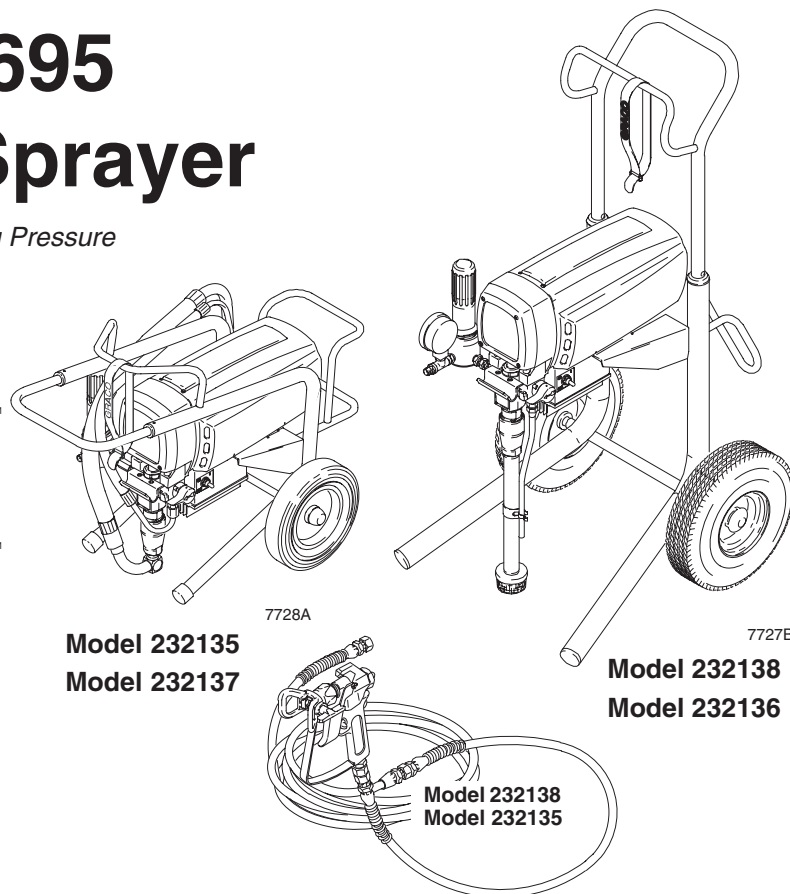

Related Manuals

Displacement Pump	308815
Fluid Filter	308249
Spray Gun	307614
Spray Tip	308644

Table of Contents

Component Function and Identification	2	Drive Housing, Connecting Rod, Crankshaft	15
Grounding	3	Pressure Transducer	16
General Repair Information	3	Pressure Transducer Seal	16
Troubleshooting	4	Suction Hose	17
Motor Test	9	Drain Valve	18
Motor Brushes	10	Technical Data	19
Displacement Pump	11	Dimensions	19
Motor	12	Accessories	19
Motor Control Board	14	Complete Sprayer Parts	20
Power Cord	14	Graco Warranty	24
On/Off Switch	14	Phone Number	24
Pressure Adjusting Potentiometer	14			

Component Function and Identification

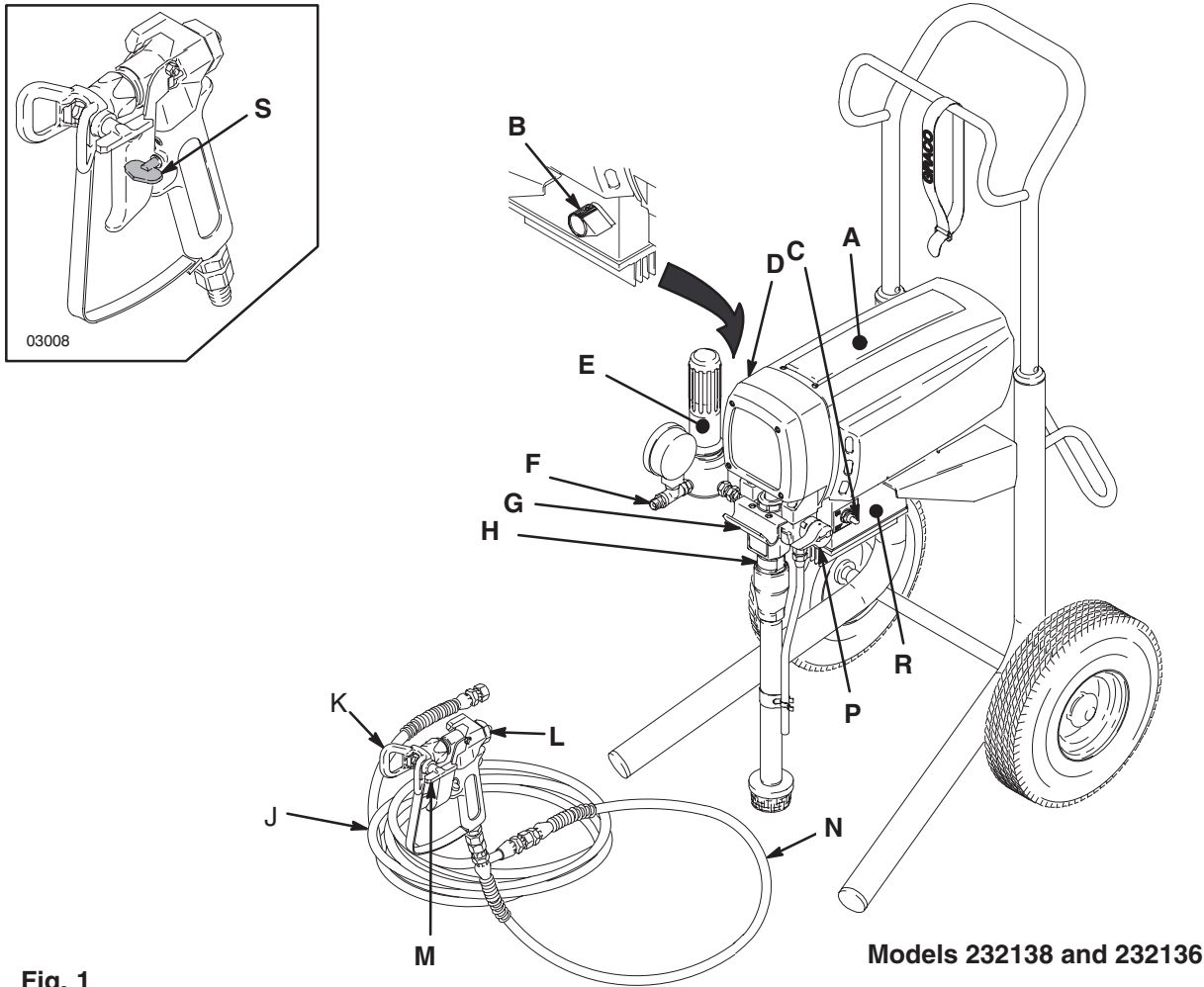

Fig. 1

7727B

A	Motor (Under shield shown)	DC motor, permanent magnet, totally enclosed, fan cooled
B	Pressure Adjusting Knob	Controls fluid outlet pressure
C	ON/OFF Switch	Power switch that controls VAC main power to sprayer
D	Drive Assembly	Transfers power from DC motor to the displacement pump
E	Fluid Filter	Filter of fluid between source and spray gun
F	Fluid Outlet	Main hose to spray gun is connected here
G	Pail Hanger	Container for fluid to be sprayed may be hung here
H	Displacement Pump	Transfers fluid to be sprayed from source through spray gun
J	50 ft (15 m) Main Hose	1/4 in. ID, grounded, nylon hose with spring guards on both ends
K	RAC IV Tip Guard	Reverse-A-Clean (RAC) tip guard reduces the risk of fluid injection injury
L	Contractor Gun	High pressure spray gun with gun safety latch
M	RAC IV Switch Tip	RAC switch tip uses high pressure fluid to remove clogs from spray tip without removing tip from spray gun
N	3 ft (0.9 m) Hose	3/16 in. ID, grounded, nylon hose used between 50 ft hose and spray gun to allow more flexibility when spraying
P	Pressure Drain Valve	Relieves fluid outlet pressure when open; diverts fluid to drain line
R	Pressure Control	Controls motor speed to maintain fluid outlet pressure at displacement pump outlet. Works with pressure adjusting knob.
S	Spray Gun Safety Latch	Inhibits accidental triggering of spray gun

General Repair Information

CAUTION

To reduce risk of pressure control malfunction:

- Use needle nose pliers to disconnect a wire. Never pull on wire, pull on connector.
- Mate wire connectors properly. Center flat blade of insulated male connector in female connector.
- Route wires carefully to avoid interference with other connections of pressure control. Do not pinch wires between cover and control box.

Tool List

Phillips screwdriver	1/4 in. hex key wrench
Small flat blade screwdriver	3/16 in. hex key wrench
Needle nose pliers	5/8 in. socket wrench
Plastic mallet or 20 oz (max) hammer	3/8 in. open end wrench
12 in. adjustable wrench	1/2 in. open end wrench
Adjustable, open-end wrench	3/4 in. open end wrench
Torque wrench	7/8 in. open end wrench
	High quality motor oil
	Bearing grease

1. **Keep all screws, nuts, washers, gaskets, and electrical fittings** removed during repair procedures. These parts are not normally provided with replacement assemblies.

WARNING



ELECTRIC SHOCK HAZARD

To reduce risk of serious injury, including electric shock, do not touch moving or electrical parts with fingers or tools while testing repair. Shut off and unplug sprayer when inspection is complete. Install all covers, gaskets, screws and washers before operating sprayer.

2. **Test repair** after problem is corrected.
3. **If sprayer does not operate properly**, review repair procedure to verify procedure was done correctly. If necessary, see Troubleshooting, page 4, for other possible solutions.

WARNING



EXPLOSION HAZARD

Motor and drive housing are very hot during operation and could burn skin if touched. Flammable materials spilled on hot, bare motor could cause fire or explosion. Have motor shield in place during operation to reduce risk of burns, fire or explosion.

CAUTION

Do not run sprayer dry for more than 30 seconds to avoid damaging pump packings.

4. **Install motor shield before operation** of sprayer and replace if damaged. Motor shield directs cooling air around motor to prevent overheating. It can also reduce risk of burns, fire or explosion; see preceding **WARNING**.

Pressure Relief Procedure

WARNING



INJECTION HAZARD

System pressure must be manually relieved to prevent system from starting or spraying accidentally. Fluid under high pressure can be injected through skin and cause serious injury. To reduce risk of injury from injection, splashing fluid, or moving parts, follow **Pressure Relief Procedure** whenever you:

- are instructed to relieve pressure,
- stop spraying,
- check or service any system equipment,
- or install or clean spray tip.

1. Lock gun safety latch.
2. Turn ON/OFF switch to OFF.
3. Unplug power cord.
4. Unlock gun safety latch. Hold metal part of gun firmly to grounded metal pail. Trigger gun to relieve pressure.
5. Lock gun safety latch.
6. Open pressure drain valve. Leave pressure drain valve open until ready to spray again.

If suspected that spray tip or hose is completely clogged, or that pressure has not been fully relieved after following steps above, VERY SLOWLY loosen tip guard retaining nut or hose end coupling to relieve pressure gradually, then loosen completely. Now clear tip or hose obstruction.

Grounding

⚠ WARNING

Improper installation or alteration of grounding plug results in risk of electric shock, fire or explosion that could cause serious injury or death.

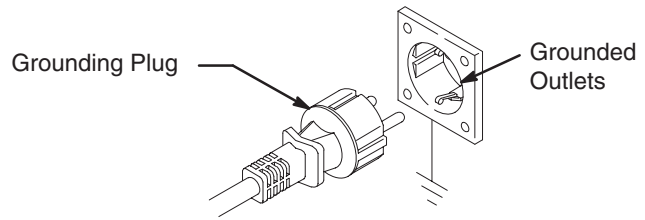

Fig. 2

230 VAC plug and outlet

1. Models 232138, 232135 require a 230 VAC, 50 Hz, 10A circuit with a grounding receptacle. Models 232136, 232137 require a 100 VAC, 50 Hz, 15A circuit with a grounding receptacle. See Fig. 2.
2. Do not alter ground prong or use adapter.

3. A 12 AWG, 3 wires with grounding prong, 300 ft (90 m) extension cord may be used. Long lengths reduce sprayer performance.

Troubleshooting



Relieve pressure; page 3.

Basic Problem Solving

TYPE OF PROBLEM	WHAT TO CHECK <i>If check is OK, go to next check</i>	WHAT TO DO <i>When check is not OK, refer to this column</i>
Fluid Pressure	1. Pressure control knob setting. Motor will not run if at minimum setting (fully counterclockwise).	1. Slowly increase pressure setting to see if motor starts.
	2. Clogged spray tip or fluid filter, if used. Refer to separate gun, tip or fluid filter instruction manual.	2. If tip is still clogged, relieve pressure; refer to separate gun or tip instruction manual for tip cleaning. Clean or replace filter element. See manual 308249.
Mechanical	1. Frozen or hardened paint in pump (18). Use a screwdriver and carefully rotate fan at back of motor. See page 12.	1. Thaw sprayer if water or water-based paint has frozen in sprayer. Place sprayer in warm area to thaw. Do not start sprayer until completely thawed. If paint hardened (dried) in sprayer the pump packings and/or pressure transducer must be replaced. See page 11 (pump) or 16 (pressure transducer).
	2. Pump connecting rod pin (14). Pin must be completely pushed into connecting rod (12), and retaining spring (15) must be firmly in connecting rod groove. See Fig. 9, page 11.	2. Push pin into place and secure with spring retainer.
	3. For motor damage. Remove drive housing assembly (2). See page 15. Try to rotate motor fan by hand.	3. Replace motor (85) if fan won't turn. See page 12.
Electrical	1. Electrical supply with volt meter. Meter must read 90–110 VAC for models 232136, 232137. Meter must read 210–250 VAC for models 232138, 232135.	1. Reset building circuit breaker; replace building fuse. Try another outlet.
	2. Extension cord for damage. Check extension cord continuity with volt meter.	2. Replace extension cord.
	3. Sprayer power cord (30) for damage such as broken insulation or wires.	3. Replace power cord. See page 14.

Basic Problem Solving

TYPE OF PROBLEM	WHAT TO CHECK <i>If check is OK, go to next check</i>	WHAT TO DO <i>When check is not OK, refer to this column</i>
Electrical <i>(continued)</i>	<p>4. Motor brushes for the following:</p> <ul style="list-style-type: none"> a. Loose terminal screws. b. Broken or misaligned brush springs. c. Brushes binding in holders. d. Broken leads. e. Worn brushes. f. Brush leads snagged on spring clip. <p>NOTE: Brushes do not wear at same rate on both sides of motor. Check both brushes.</p>	<p>4. Refer to page 10.</p> <ul style="list-style-type: none"> a. Tighten. b. Replace broken spring and/or align spring with brush c. Clean brush holders. Remove carbon with small cleaning brush. Align brush leads with slot in brush holder to assure free vertical brush movement. d. Replace brushes e. Replace brushes if less than 0.5 in. (12.5 mm) long. f. Correctly route wires. See page 10.
	<p>5. Motor armature commutator for burn spots, gouges and extreme roughness. Remove motor cover and brush inspection plates to check. See page 10.</p>	<p>5. Remove motor and have motor shop resurface commutator if possible. See page 12.</p>
	<p>6. Motor armature for shorts using armature tester (growler) or perform motor test. See page 9.</p>	<p>6. Replace motor. See page 12.</p>
	<p>7. That leads from pressure transducer and motor to motor control board (22a) are securely fastened and properly mated.</p>	<p>7. Replace loose terminals; crimp to leads. Be sure male terminal blades are straight and firmly connected to mating part.</p>
	<p>8. Motor control board (22a) by performing motor control board diagnostics on page 13. If diagnostics indicate, substitute with a good board.</p> <p>CAUTION: Do not perform this check until motor armature is determined to be good. A bad motor armature can burn out a good board.</p>	<p>8. Replace board. See page 13.</p>
	<p>9. power cord (30). Models 232138, 232135. Disconnect brown and blue power cord terminals; connect volt meter to these leads. Plug in sprayer. Meter must read 210–250 VAC. Models 232136, 232137. Disconnect black and white power cord terminals; connect volt meter to these leads. Plug in sprayer. Meter must read 90–110 VAC. Unplug sprayer.</p>	<p>9. Replace power cord. See page 14.</p>
	<p>10. ON/OFF switch (80). Models 232138, 232135. Disconnect brown wire (96) between motor control board (22a) and switch and connect volt meter between exposed terminal switch and power cord blue wire (94). Plug in sprayer and turn ON. Meter must read 210–250 VAC. Models 232136, 232137. Disconnect black wire (96) between motor control board (22a) and switch and connect volt meter between exposed terminal of (96) and power cord white wire. Plug in sprayer and turn ON. Meter must read 90–110 VAC. Turn OFF and unplug sprayer.</p>	<p>10. Replace ON/OFF switch. See page 14.</p>
	<p>11. Motor thermal cutout switch. Connect ohmmeter between motor yellow leads. Meter must read 1 ohm maximum.</p>	<p>11. Allow motor to cool. Correct cause of overheating. If switch remains open after motor cools, replace motor.</p>
	<p>12. Pressure transducer (67) by replacing it with a new one.</p>	<p>12. Replace pressure transducer. See page 16.</p>
	<p>13. Pressure adjustment potentiometer (77) by replacing it with a new one.</p>	<p>13. Replace potentiometer. See page 14.</p>

Intermediate Problem Solving

TYPE OF PROBLEM	WHAT TO CHECK <i>If check is OK, go to next check</i>	WHAT TO DO <i>When check is not OK refer to this column</i>
Low output	1. For worn spray tip.	1. Follow Pressure Relief Procedure Warning on page 3, then replace tip. See your separate gun or tip manual.
	2. Verify pump does not continue to stroke when gun trigger is released. Plug in and turn on sprayer. Prime with paint. Trigger gun momentarily, then release and engage safety latch. Relieve pressure, turn off and unplug sprayer.	2. Service pump. See page 11.
	3. Release gun trigger. Observe resting position of pump rod (222).	3. If pump consistently comes to rest with rod (222) fully extended, the piston packings and/or piston valve may be worn. Service pump. See page 11.
	4. Electrical supply with volt meter. Meter must read 90–110 VAC for models 232136, 232137. Meter must read 210–250 VAC for models 232138, 232135.	4. Reset building circuit breaker; replace building fuse. Repair electrical outlet or try another outlet.
	5. Extension cord size and length; must be at least 12 AWG (1.5 mm ²) and no longer than 300 ft (90 m).	5. Replace with a correct, grounded extension cord.
	6. Motor brushes. See Electrical – What To Check, item 4, on page 5.	6. See page 10.

Intermediate Problem Solving

TYPE OF PROBLEM	WHAT TO CHECK <i>If check is OK, go to next check</i>	WHAT TO DO <i>When check is not OK, refer to this column</i>
Low output <i>(continued)</i>	7. Motor control board (22a) by substituting with a good board. CAUTION: Do not perform this check until motor armature is determined to be good. A bad motor armature can burn out a good board.	7. Replace board. See page 13.
	8. Motor armature for shorts by using an armature tester (growler) or perform motor test. See page 9.	8. Replace motor. See page 12
Drain valve leaks	1. Drain valve for correct torque and/or worn parts. Check for debris trapped on seat.	1. Tighten to 185 in-lb (21 N-m). Clean valve and replace with new gasket (55) and sealant 110–110. See page 18.
No output: motor runs and pump strokes	1. Paint supply.	1. Refill and reprime pump.
	2. For clogged intake strainer.	2. Remove and clean, then reinstall.
	3. For loose suction tube or fittings. See page 17.	3. Tighten; use thread sealant on npt threads of suction tube (43). Check for damaged o-ring (45).
	4. To see if intake valve ball and piston ball are seating properly. See page 11.	4. Remove intake valve and clean. Check ball and seat for nicks; replace as needed. See page 11. Strain paint before using to remove particles that could clog pump.
	5. For leaking around throat packing nut which may indicate worn or damaged packings. See page 11.	5. Replace packings. See page 11. Also check piston valve seat for hardened paint or nicks and replace if necessary. Tighten packing nut.
	6. Release gun trigger. Observe resting position of pump rod (222).	6. If pump consistently comes to rest with rod (222) fully extended, piston packings and/or piston valve may be worn. Service pump. See page 11.
No output: motor runs but pump does not stroke	1. Displacement pump connecting rod pin (14). See Fig. 9, page 11.	1. Replace pin if missing. Be sure retainer spring (15) is fully in groove all around connecting rod.
	2. Connecting rod assembly (12) for damage. See page 15.	2. Replace connecting rod assembly. See page 15.
	3. Be sure crank in drive housing rotates; plug in sprayer and turn on briefly to check. Turn off and unplug sprayer. See page 15.	3. Check drive housing assembly for damage and replace if necessary. See page 15.
Spray pattern variations	1. Spray tip worn beyond sprayer pressure capability.	1. Replace spray tip. NOTE: Smaller size tip provides longer life.
	2. Motor control board (22a) by performing motor control board diagnostics on page 13. If diagnostics indicate, substitute with a good board. CAUTION: Do not perform this check until motor armature is determined to be good. A bad motor armature can burn out a good board.	2. Replace board. See page 13.

Intermediate Problem Solving

TYPE OF PROBLEM	WHAT TO CHECK <i>If check is OK, go to next check</i>	WHAT TO DO <i>When check is not OK, refer to this column</i>
Spray pattern variations <i>(continued)</i>	3. Pressure adjustment potentiometer (77) by replacing with a new one. 4. Low Output section, page 6.	3. Replace potentiometer. See page 14..
Motor is hot and runs intermittently	1. Determine if sprayer was operated at high pressure with small tips, which causes excessive heat build up. 2. Be sure ambient temperature where sprayer is located is no more than 90°F (32°C) and sprayer is not located in direct sun. 3. Motor.	1. Decrease pressure setting or increase tip size. 2. Move sprayer to shaded, cooler area if possible. 3. Replace motor. See page 12.
Building circuit breaker opens as soon as sprayer switch is turned on.	1. All electrical wiring for damaged insulation, and all terminals for loose fit or damage. Also check wires between pressure transducer and motor. See page 12. 2. For missing motor brush inspection plate gasket (see page 10), bent terminal forks or other metal to metal contact points which could cause a short. 3. Motor armature for shorts. Use an armature tester (growler) or perform motor test. See page 9. Inspect windings for burns. 4. Motor control board (22a) by performing motor control board diagnostics on page 13. If diagnostics indicate, substitute with a good board. CAUTION: Do not perform this check until motor armature is determined to be good. A bad motor armature can burn out a good board	1. Repair or replace any damaged wiring or terminals. Securely reconnect all wires. 2. Correct faulty conditions. 3. Replace motor. See page 12. 4. Replace board. See page 13.
Circuit breaker opens after sprayer operates for 5 to 10 minutes.	1. Basic Problems – Electrical’ on page 4.	
Building circuit breaker opens as soon as sprayer is plugged into outlet and sprayer is not turned on.	1. ON/OFF switch (80). Be sure sprayer is unplugged! Disconnect wires from switch. Check switch with ohmmeter. The reading should be infinity with ON/OFF switch OFF, and zero with switch ON. CAUTION: A short in motor circuit can damage switch and or motor control board (22a). 2. For damaged or pinched wires in junction box (20).	1. Replace ON/OFF switch. See page 14. 2. Replace damaged parts.
Unit will not run on generator but does run on AC power	1. Generator “peak” voltage. Sprayer will not run if peak voltage is above 165 or below 75 VAC for models 232136, 232137 or above 260V or below 180V for models 232138, 232135.	1. Use AC power or a different generator.

Motor Test



Relieve pressure; page 3.

For checking armature, motor winding and brush electrical continuity.

Setup

1. Unplug sprayer.
2. Remove drive housing. See page 15. This ensures that any resistance noticed in armature test is due to motor and not to worn gears in drive housing.
3. Fig. 3. Remove brush inspection covers (A).
4. Fig.4. Remove screws (25, 26). Lower control board (22a). Disconnect two leads (C) from motor to board.

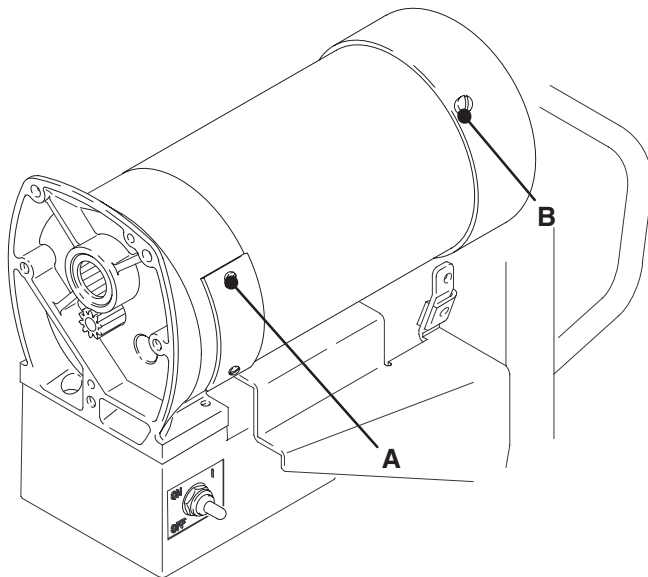

Fig. 3

02991

Armature Short Circuit Test

1. Remove fan cover (B). See Fig.3.
2. Spin motor fan by hand. If there are no shorts, motor coasts two or three revolutions before coming to complete stop. If motor does not spin freely, armature is shorted and motor must be replaced. See page 12.

Armature, Brushes, and Motor Wiring Open Circuit Test (Continuity)

1. Fig. 4 Connect red and black motor leads (C) together with a test lead. Turn motor fan by hand at about two revolutions per second.

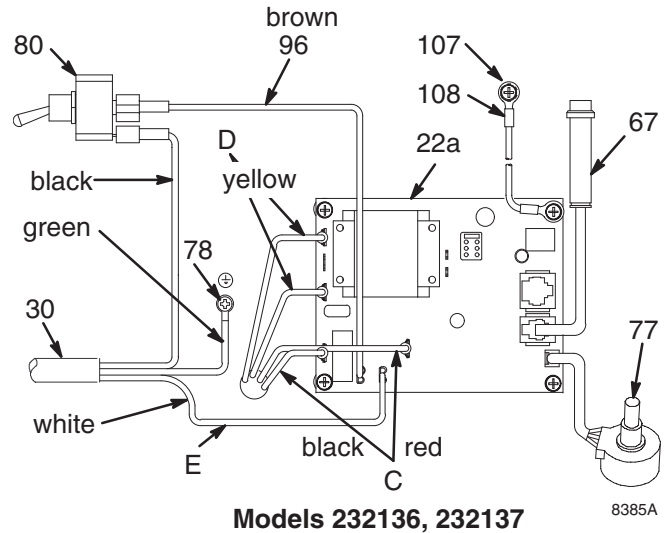

Models 232136, 232137

8385A

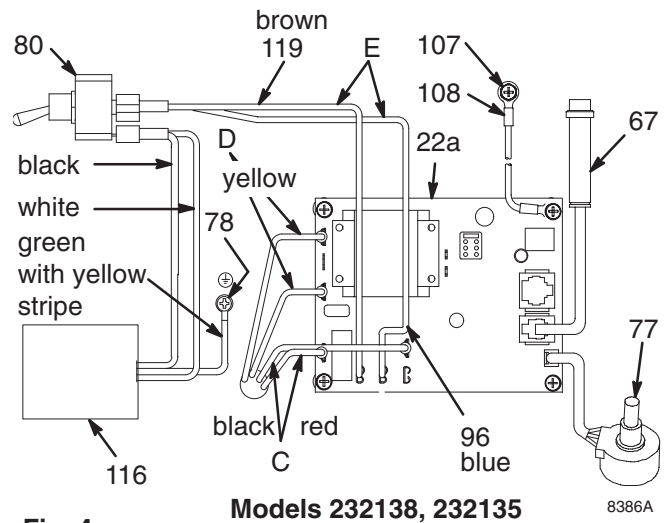

Models 232138, 232135

8386A

Fig. 4

2. If uneven or no resistance, check for: broken brush springs, brush leads, motor leads; loose brush terminal screws or motor lead terminals; worn brushes. See page 10.
3. If still uneven or no resistance, replace motor; page 12.

Motor Brushes

NOTE: Replace brushes worn to less than 13 mm (0.5 in.). Check both brushes. Use Brush Repair Kit 236967 for motor brush repair.



Relieve pressure; page 3.

1. Unplug sprayer.
2. Remove both inspection covers (A) and their gaskets. See Fig.5.

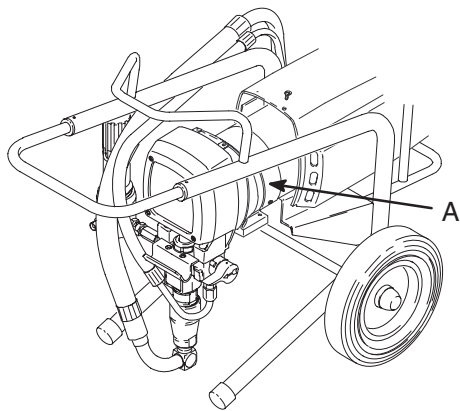

7735A

Fig. 5 Models 232135, 232137

3. Push in spring clip (F) and release hooks (G) from brush holder (B). Pull out spring clip. See Fig. 6.
4. Inspect commutator for excessive pitting, burning or gouging. A black color on commutator is normal. Have commutator resurfaced by a qualified motor repair shop if brushes seem to wear too fast or arc excessively. See Step 9.d., also.
5. Repeat for other side.
6. Place a new brush (C) in holder (B) so ramp (H) faces spring. See Fig. 6.
7. Holding spring clip (F) at a slight angle, slide spring clip into brush holder and hook it over end of holder. See Fig. 7. Pull on spring clip to be sure it stays in place. Connect brush lead to blade connector (E).
8. Repeat for other side.
9. **Test brushes.**
 - a. Remove pump connecting rod pin (14).

⚠ WARNING

ELECTRIC SHOCK HAZARD
Do not touch the brushes, leads, springs or brush holders while the sprayer is plugged in to reduce the risk of electric shock and serious bodily injury.

- b. With sprayer OFF, turn pressure control knob fully counterclockwise to minimum pressure. Plug in sprayer.
 - c. Turn sprayer ON. Slowly increase pressure until motor is at full speed.
 - d. Inspect brush and commutator contact area for excessive arcing. Arcs must not trail or circle around commutator surface.
10. Install brush inspection covers and gaskets.
 11. Install pump connecting rod pin (14).

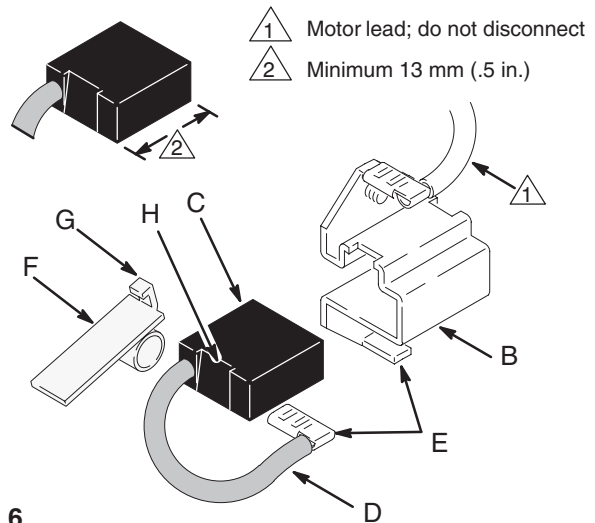

Fig. 6

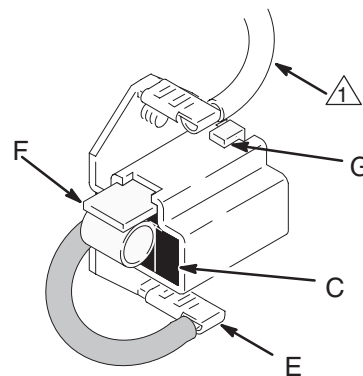

Fig. 7

03881

Displacement Pump

NOTE: Packing Repair Kit 235703 is available. Reference numbers of parts included in the kit are marked with an asterisk, i.e., (223*).

Removing pump (See Fig.8)

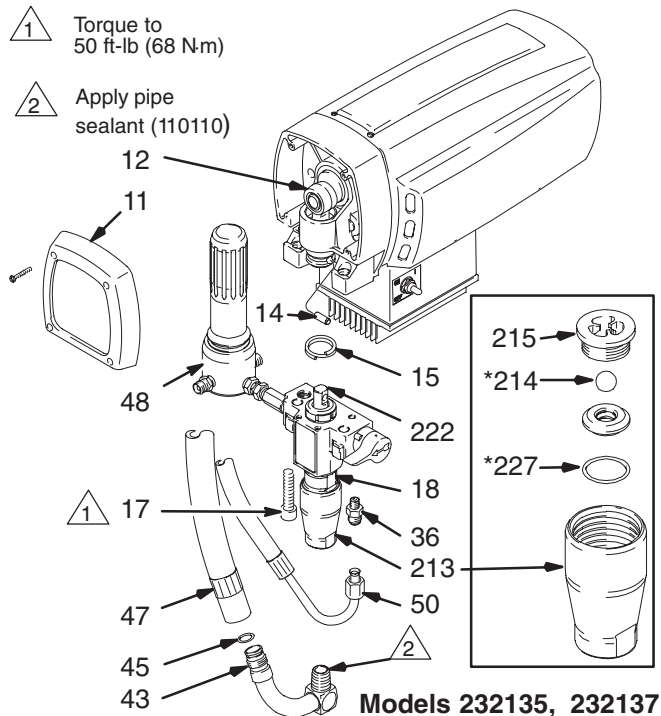



Fig. 8 7736A

1.  Relieve pressure; page 3.
2. Flush pump, if possible. Relieve pressure. Stop pump with piston rod (222) in its lowest position, if possible. To lower piston rod manually, rotate motor fan blades.
3. Remove filter (48).
4. **Models 232135, 232137.** While pulling upward on suction hose (47), unscrew hose from inlet tube (43). Unscrew drain hose (50) from displacement pump nipple (36).
5. **Models 232138, 232136.** Remove suction tube (43). Unscrew drain tube (84) from displacement pump nipple (36).
6. Use a screwdriver to push retaining spring (15) up and push out pin (14).

7. Loosen screws (17). Remove pump (18).

Repairing pump

See manual 308815 for displacement pump repair instructions and parts.

Installing pump (See Fig. 8 and 9)

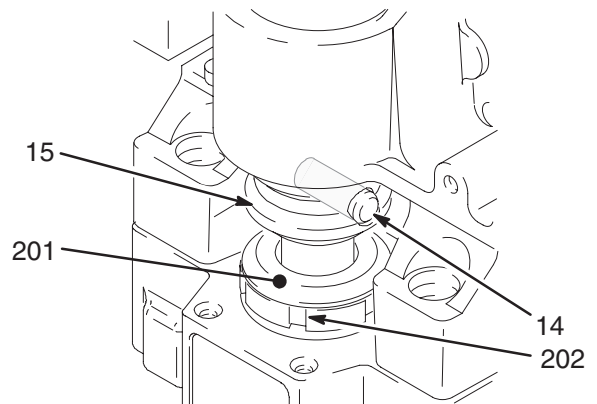

Fig. 9 7840A

1. Lightly grease or oil transducer (67). See Fig. 15. Guide pump over alignment pins and pressure transducer. Tap it into position with a soft hammer. Tighten screws (17) to 50 ft-lb (68 N·m).
2. Align hole in rod (222) with connecting rod assembly (12). Use screwdriver to push retaining spring (15) up and push in pin (14). Push retaining spring into place around connecting rod.

⚠ WARNING

MOVING PARTS HAZARD
Be sure retaining spring (18) is firmly in groove all around, to prevent pin (14) from working loose. See Fig. 9.

If pin works loose, parts (including pump connecting rod or bearing housing) could project into the air and cause serious injury or property damage.

3. Replace o-ring (45) if worn or damaged. See page 17. Reconnect suction and drain hoses (47, 50). Install front cover (11).
4. Tighten packing nut (202) enough to stop leakage, but no tighter. Fill packing nut full with Graco TSL. Push plug (201) into packing nut.

Motor

NOTE: See Fig. 12 except where noted.

1. Try to stop pump with piston rod (222) in lowest position. To lower piston rod manually, remove shroud (32) and rotate motor fan blades. Use a screwdriver to push retaining spring (15) up and push out pin (14). See Fig. 10.



2. Relieve pressure; page 3.

3. Remove motor shield (32).

4. Lift connecting rod. Remove screws (25, 26) and lower heat sink (22) and motor control board (22a). Disconnect motor wires and pressure transducer wire (A) from motor control board. Remove heat sink (22) and motor control board (22a), screws (23), and junction box (20). Refer to Fig. 12 and 4.

5. Remove drive housing cover (11).

6. Turn displacement pump rod (222) so pin hole aligns with bottom drive housing screw (16). See Fig. 11. Remove three drive housing screws and lockwashers (16, 4). See Fig. 11 and 12.

7. Remove two motor screws and lockwashers (3, 4).

8. Tap lower rear of drive housing (2) with a plastic mallet to loosen motor. Pull drive housing straight off motor while guiding pressure transducer wire (A) from motor. Do not allow gear (13) to fall. Read CAUTION on page 15.

9. Remove four screws (75) and lift motor off cart (70).

10. Align new motor with cart and reinstall screws (75).

11. Assemble drive housing to motor. Follow steps 9 to 15 on page 15. Install junction box.

12. Connect wires to motor control board (22a). Refer to Fig. 4. Install motor control board.

13. Connect piston rod (222) to drive housing; see page 11, **Installing Pump**, Step 2 and WARNING following it.

14. Install shroud (32) and drive housing cover (11).

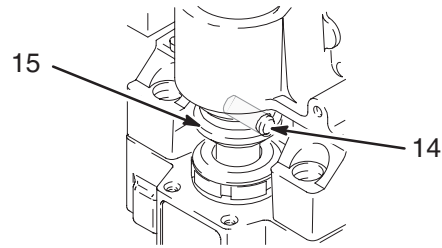

Fig. 10 7840A

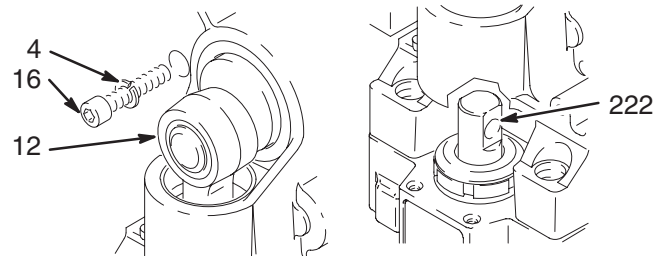
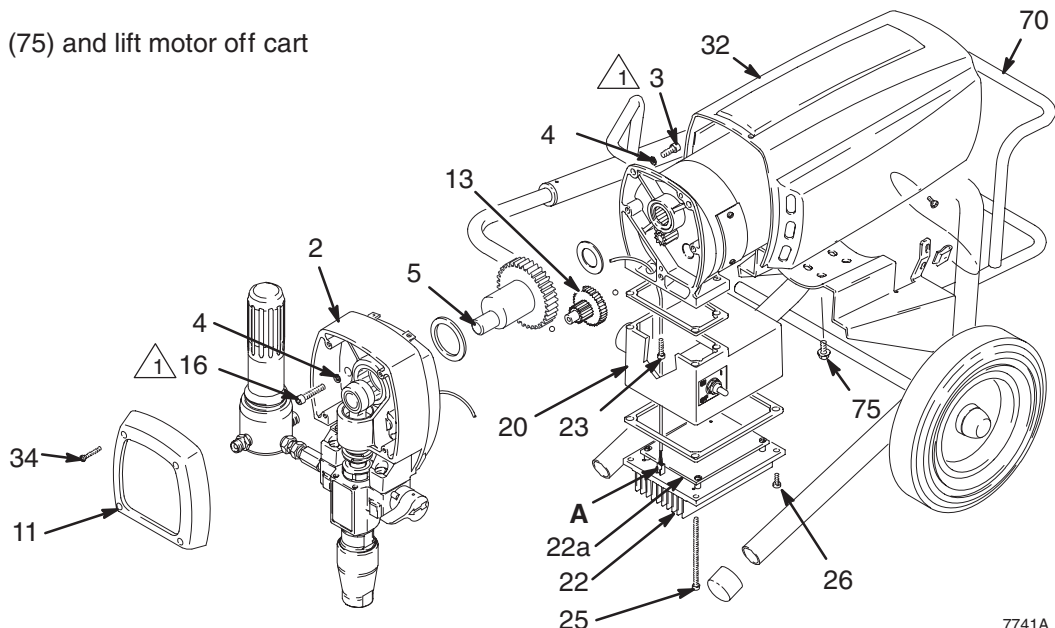

Fig. 11 7840A



1 Torque to 80 in-lb (9 Nm)

7741A

Models 232135, 232137

Fig. 12

Pressure Control Repair

Motor control board removal

1.  Relieve pressure; page 3.
2. Remove screws (25, 26) and lower heat sink (22) and motor control board (22a). See Fig. 12.
3. Disconnect wires (C), (D), (96), (E) and 108 from motor control board (22a). See Fig. 4.
4. Disconnect potentiometer (77) and transducer (67) from motor control board (22a).
5. Remove four screws and motor control board (22a).

6. Install new motor control board (22a) with four screws. Reconnect all wires and secure heat sink (22) to junction box (20).

CAUTION

To reduce the risk of a malfunction:

- Be sure the flat blade of the insulated male connector is centered in the wrap-around blade of the female connector when the connections are made.
- Route all wires carefully to avoid interference with the motor control board or junction box.

Motor control board diagnostics

1.  Relieve pressure; page 3.
2. Remove screws (25, 26) and lower heat sink (22) and motor control board (22a). See Fig. 12.
3. Turn ON/OFF switch ON.
4. Observe LED operation and reference following table:

LED BLINKS	SPRAYER OPERATION	INDICATES	WHAT TO DO
Once	Sprayer runs	Normal operation	Do nothing
Twice	Sprayer runs	Normal operation	Do nothing
Two times repeatedly	Sprayer shuts down and LED continues to blink two times repeatedly	Run away pressure. Pressure greater than 4500 psi.	Replace motor control board. See preceding Motor control board removal procedure.
Three times repeatedly	Sprayer shuts down and LED continues to blink three times repeatedly	Pressure transducer is faulty or missing	Replace pressure transducer
Four times repeatedly	Sprayer shuts down and LED continues to blink four times repeatedly	Line voltage is too high	Lower line voltage to 230 VAC for models 232138, 232135 and to 100 VAC for models 232136, 232137
Five times repeatedly	Sprayer shuts down and LED continues to blink five times repeatedly	Locked rotor. Motor can not turn because of some mechanical condition.	Clear obstruction and replace broken parts preventing motor from turning

Power Cord

Models 232136 and 232137

1.  Relieve pressure; page 3.
2. Remove screws (25, 26) and lower heat sink (22). See Fig. 12.
3. Disconnect power cord leads (30), including green wire to grounding screw (78). See Fig. 4.
4. Loosen strain relief bushing (29). Remove power cord (30).
5. Install new cord (30) in reverse order of disassembly.

6. Install heat sink (22). Be sure no leads are pinched between heat sink and junction box (20).

Models 232135 and 232138

1.  Relieve pressure; page 3.
2. Loosen screw on power cord retainer (120) and remove power cord (30).
3. Install new power cord (30) and tighten screw on power cord retainer (120).

On/Off Switch

1.  Relieve pressure; page 3.
2. Remove screws (25, 26) and lower heat sink (22). See Fig. 14.
3. Remove rubber boot (82). See page 20.
4. Disconnect black, white, brown and blue wires from ON/OFF switch (80) and remove switch. See Fig. 4.

5. Install switch so internal tab of anti-rotation ring (81) engages with vertical groove in threads of switch, and external tab engages with slot of junction box. See page 20.
6. Powder inside of rubber boot (82) with talcum, then shake excess out of boot. Install nut and rubber boot and tighten.
7. Reconnect black, white, brown and blue wires to ON/OFF switch (80).
8. Install heat sink (22) with screws (25, 26). See Fig. 14. Be sure no leads are pinched between motor control board or other components.

Pressure Adjusting Potentiometer

1.  Relieve pressure; page 3.
2. Remove screws (25, 26) and lower heat sink (22). See Fig. 14.
3. Remove potentiometer knob (27).
4. Remove shaft sealing nut (76).

5. Disconnect and remove potentiometer (77).
6. Install and connect new potentiometer (77).
7. Install shaft sealing nut (76).
8. Install potentiometer knob (27).
9. Install heat sink (22) with screws (25, 26). See Fig. 14. Be sure no leads are pinched between motor control board or other components.

Drive Housing, Connecting Rod, Crankshaft

NOTE: Inspect parts as they are removed. Replace parts that are worn or damaged.

1.  Relieve pressure; page 3.
2. Remove displacement pump. See page 11.
3. Remove shroud (32).
4. Lower heat sink (22) and remove pressure transducer (67). See page 16.

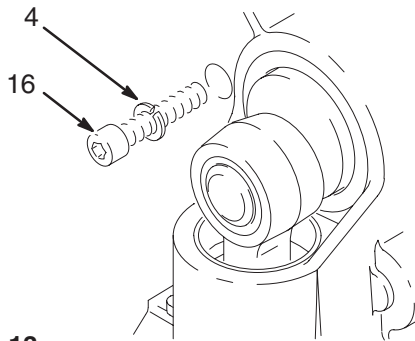

Fig. 13 7840A

5. Remove three drive housing screws (16) and lockwashers (4). Also see Fig. 14.
6. Remove two motor screws and lockwashers (3, 4). See Fig. 14.

⚠ CAUTION

Do not allow gear (13) to fall; gear may stay attached to the drive housing or to the motor.

Do not lose the thrust balls (2a or 41) or let them fall between the gears, which will damage the drive housing if not removed. The balls, which are heavily covered with grease, usually stay in the gear recesses, but could be dislodged. If the balls are not in place, the bearings will wear prematurely.

7. Tap lower rear of drive housing (2) with a plastic mallet to loosen motor. Pull drive housing straight off motor.
8. Remove and inspect crankshaft (5) and connecting rod (12). Replace all damaged or worn parts.
9. Install connecting rod.
10. Lubricate inside of connecting rod bearing with SAE non-detergent oil. Pack roller bearing and gears with grease supplied.

NOTE: The gears and bearings between the drive housing (2) and motor front end bell (C) should contain a total of 3 fl oz (89 cc) of grease.

11. Place large washer (6) and then small washer (7) on crankshaft (5).
12. Rotate crank to top of stroke and insert crankshaft (5). Align gears and push drive housing (2) straight onto motor and locating pins. Install screws (16, 3) and their lockwashers (4). Torque to 80 in-lb (9 N·m).
13. Plug in pressure transducer. See page 16.
14. Install displacement pump. See page 11.
15. Install front cover (11).
16. Replace shroud (32).
17. Replace heat sink (22).

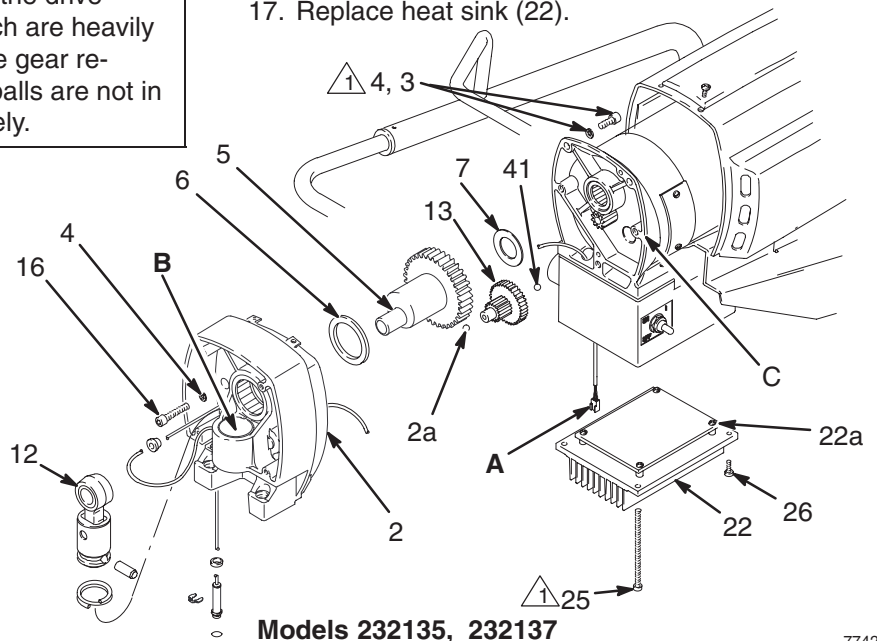

 Torque to 80 in-lb (9 Nm)

Fig. 14

7742A

Pressure Transducer

NOTE: See Fig. 14 and 15 for this procedure.

NOTE: The pressure transducer (67) cannot be repaired or adjusted. If it malfunctions, replace it.

Removal

1.  Relieve pressure; page 3.
2. Remove displacement pump (18). See page 11.
3. Remove front cover (11). Remove screws (25, 26). Lower heat sink (22).
4. Disconnect harness connector from motor control board (22a). Remove grommet (65).
5. Remove retaining ring (66). Pull pressure transducer down and out past drive housing (2).
6. Guide harness (A) through motor and drive housing and remove pressure transducer.
7. Inspect spacer (68) and seal (69) for damage. Replace seal (69) only if it is cut, nicked, or if leakage occurred. See page 16.

Installation

1. Using a small piece of solid copper or mild steel wire (approximately 12 in.), form a small hook and place it in the passage of bottom of the motor. Guide it up and out the hole in the drive housing.
2. Pass a spacer (68) over harness connector (A) and down into position at bottom of transducer (67).

3. Guide harness up through leg and notch of drive housing (2). Secure guide wire over connector.
4. While pulling guide wire out through bottom of motor, guide harness through drive housing and motor castings.
5. Place grommet (65) over harness and push into position in drive housing hole.
6. Feed excess harness cable through grommet and fully seat transducer body into hole in drive housing leg. Secure it with retaining ring (66).
7. Attach connector to motor control board (22a). Replace cover (11) and heat sink (22). Ensure no wires are pinched between components.

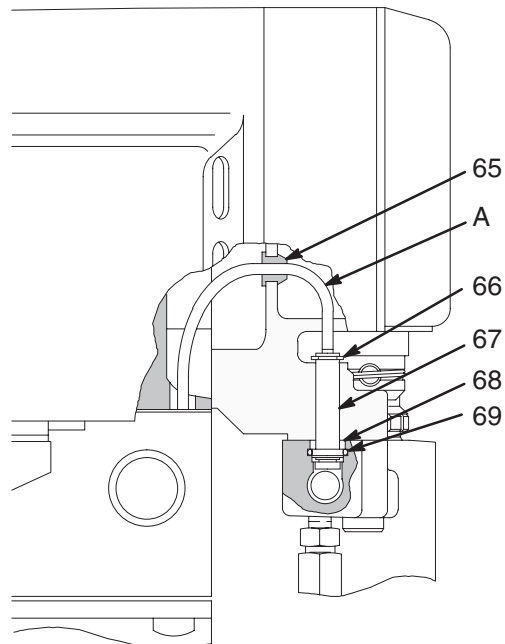

Fig. 15

02996A

Pressure Transducer Seal

NOTE: PTFE seal is unaffected by most solvents and materials. Replace seal only when leakage occurs.

Removal

1.  Relieve pressure; page 3.

2. Remove displacement pump (18). See page 11.
3. Remove seal (69) from recess in manifold (229).
4. Clean manifold recess with solvent and cloth or cotton swabs. Inspect for nicks or scratches.

Pressure Transducer Seal

Installation

1. Lightly coat cleaned packing recess in manifold with a light grease or oil.
2. Heat seal (69) in hot water for several minutes.

CAUTION

Excess pressure from the probes or fingernails will damage the packing and cause subsequent leakage.

3. Use a blunt wooden or plastic probe and install seal (69) into recess in manifold (229). Be careful not to cause kinks or bends in packing during installation.

4. Lightly grease or oil transducer (67) and install pump (18). See page 11.

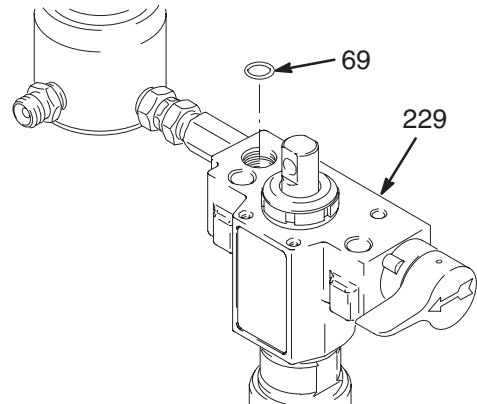



Fig. 16

7743A

Suction Hose (Models 232135, 232137)

1.  Relieve pressure; page 3.
2. Remove drain hose (50) from clip.
3. Pull upward on suction hose (47) while unscrewing it from inlet tube (43). The hose coupling (A) threads will engage and the hose will separate from the tube.
4. Replace o-ring (45) if it is worn or damaged.
5. Lubricate o-ring (45) and inlet tube (43) threads with light grease.
6. Align suction hose coupling (A) with threads of inlet tube (43). Tighten hose onto tube at least 4 turns to ensure that threads have disengaged and can function as a swivel joint.

CAUTION

Misalignment or cross-threading will damage the parts and/or create shavings which can cause the o-ring (45) to leak.

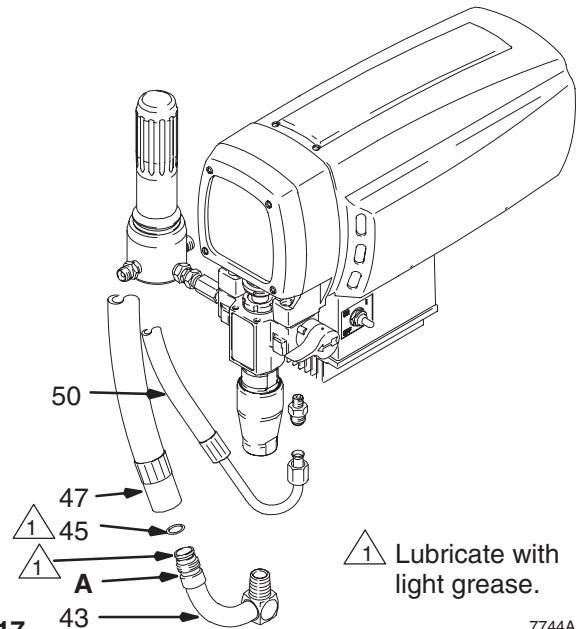

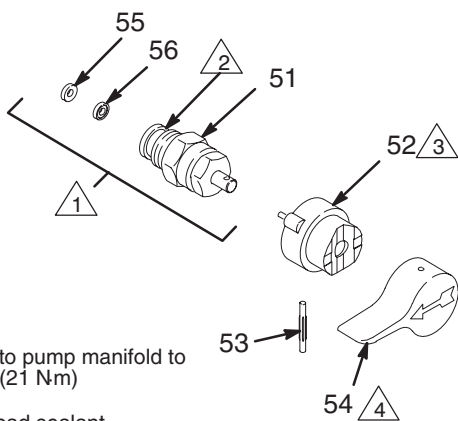

Fig. 17

7744A

Drain Valve

1.  Relieve pressure; page 3.
2. Turn handle (54) to closed position. Drive out pin (53). Remove handle.
3. Remove base (52).
4. Unscrew drain valve assembly (51). gasket (55) and seat (56) will stay in valve.







- 1  Torque into pump manifold to 185 in-lb (21 N.m)
- 2  Apply thread sealant
- 3  Apply grease to face of base
- 4  Handle shown in closed position

Fig. 18

7839A

Repair

1. Unscrew spring retainer from valve body. Remove spring, washers and stem/ball. Clean any debris from ball or seat area.
2. If replacing gasket (55) or seat (56), pry out gasket.

NOTE: Whenever gasket (55) is removed, replace it with a new one.

3. Place seat (56) in drain valve assembly (51) so lapped side is toward ball. Apply a small amount of grease to new gasket (55) and install it in drain valve assembly.

NOTE: The gasket will protrude from the end of the valve until the valve is tightened into pump, which correctly seats the gasket.

Replacement

1. Apply a small amount of thread sealant (110110) onto drain valve assembly (51) threads. Tighten the valve into the pump manifold (229) to 185 in-lb (21 N.m).
2. Lightly grease face of base (52) and install base. Turn stem so pin hole is vertical.
3. Securely install handle (54) and drive pin (53).

Technical Data

Power Requirements
 Model 232138, 232135 230 VAC, 50 Hz,
 1 phase, 10A minimum
 Model 232136, 232137 100 VAC, 50 Hz,
 1 phase, 15A minimum
 Generator 3000W minimum
 Working Pressure Range 0–3000 psi
 (0–210 bar, 21 MPa)
 Motor 0.9 HP
with latex at 2000 psi (138 bar, 13.8 MPa)
 Cycles/Gallon (liter) 566 (150)
 Maximum Delivery Rating 0.6 gpm (2.3 lpm)
 Tip Size one gun to 0.024 new tip
with latex at 2000 psi (138 bar, 13.8 MPa)
 Power Cord 14 AWG, 3 wire, 15 ft (4.5 m)

Inlet Paint Strainer 16 mesh (975 micron)
 Stainless Steel Screen, reusable
 Outlet Filter60 mesh (238 micron)
 Pump Inlet Size 3/4 npt(f)
 Fluid Outlet Size 1/4 npsm
 Sound Data:
 Sound Pressure Level 82dB(A)*
 Sound Power Level 91dB(A)*
 *Measured while spraying with a .017 tip per ISO–3744
 Wetted Parts: Zinc-plated carbon steel,
 Aluminum, Stainless steel,
 Polyethylene, Delrin®, Leather
 Tungsten carbide, Chrome plating, Polyurethane
NOTE: PTFE[®] and Delrin[®] are trademarks of the Company

Dimensions

Model 232135, 232137

Weight (dry w/o packaging) 61 lb (27.7 kg)
 Length (handle collapsed) 25.5 in. (648 mm)
 Width 15 in. (381 mm)
 Height 20 in. (508 mm)

Model 232138, 232136

Weight (dry w/o packaging) 73 lb (33.1 kg)
 Length 21 in. (533 mm)
 Width 20.5 in. (521 mm)
 Height (Handle Down) 28.5 in. (711 mm)

Accessories

DANGER LABELS

An English language DANGER label is on your sprayer. If you have painters who do not read English, order one of the following labels to apply to your sprayer. The drawing below shows the best placement of these labels for good visibility.

Order the labels directly from Graco, free of charge:
 1–800–328–0211

French	187784
Spanish	185956
German	185961
Greek	186041
Korean	186045
English	187791

Apply other
 language here

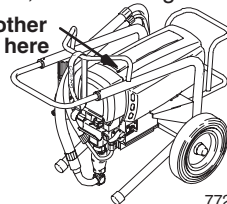

7728A

Complete Sprayer Parts

Model 232135, Series A
 Model 232137, Series A

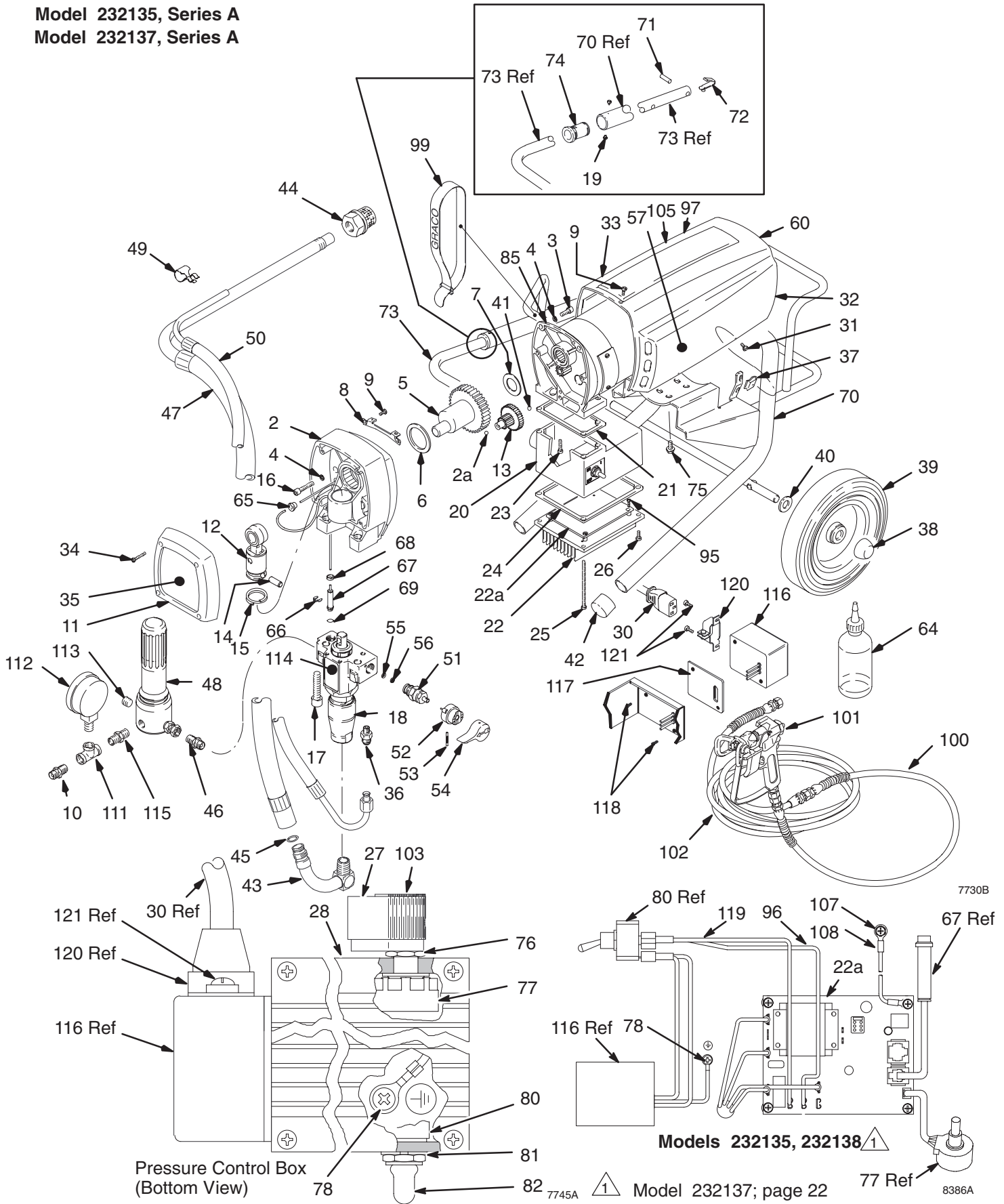

Models 232135, 232138

1 Model 232137; page 22

Complete Sprayer Parts

Model 232135, Series A; Model 232137, Series A

Ref. No.	Part No.	Description	Qty.	Ref. No.	Part No.	Description	Qty.
2	240057	KIT, housing, drive, U-695	1	54	187625	HANDLE, drain valve	1
2a	100069	BALL, thrust	1	55	111699	GASKET, seat valve	1
3	101682	SCREW, sch, 1/4–20 x .625	2	56	187615	SEAT, valve, lapped	1
4	105510	LOCKWASHER, 1/4 hi-collar	5	57▲		LABEL, DANGER, English	2
5	239979	CRANKSHAFT, U-695	1		187791	Model 232135	2
6	180131	BEARING, thrust, front	1		189702	Model 232137	2
7	107434	BEARING, thrust, rear	1	60▲		LABEL, WARNING, elec shock	1
8	189270	BRACKET, shield	1		187975	Model 232138	1
9	108865	SCREW, panh	4		193520	Model 232136	1
10	162453	NIPPLE, 1/4 npt x 14 npsm	1	64	206994	LIQUID, throat seal	1
11	236366	KIT, cover, front, U-695	1	65	114296	GROMMET, cable	1
12	240519	CONNECTING, rod assy	1	66	112396	RING, external retaining	1
13	218364	GEAR, assy, 2nd stage	1	67	240514	TRANSDUCER, pressure control	1
14	176818	PIN, straight	1	68	189269	SPACER, transducer	1
15	176817	SPRING, retaining	1	69	104319	PACKING, o-ring,PTFE ¹	1
16	103345	SCREW, sch, 1/4–20 x 1.25	3	70	239999	FRAME, cart, U-695	1
17	111706	SCREW, mach, sch, 7/16 x 1.75	2	71	109567	PIN, spring, straight	2
18	239769	KIT, pump, displacement see manual 308815	1	72	178565	BUTTON, spring	1
19	112620	SCREW, 6–32 x 0.187	4	73	189934	HANDLE, cart	1
20		HOUSING, junction box		74	280290	BUSHING, sleeve, molded	2
	194435	Model 232135	1	75	110997	SCREWS, 1/4–20 x .625	4
	189105	Model 232137	1	76	112382	NUT, shaft sealing	1
21	112158	GASKET, motor	1	77	236352	POTENTIOMETER, pressure adj	1
22	192844	HEAT SINK, does not include 22a	1	78	110037	SCREW, sltd hex hd, 10–24 x .375	1
22a		KIT, board, control, motor see manual 308816		80		SWITCH, toggle	1
	240561	Model 232135	1		111826	Model 232135	1
	240168	Model 232137	1		111930	Model 232137	1
23	112379	SCREW, filh, 10–24 x 0.75	2	81	105658	RING, locking	1
24	112159	GASKET, heatsink	1	82	105659	BOOT, toggle	1
25	112381	SCREW, panh, 10–24 x 3.5	2	85		KIT, motor, electric, DC	
26	114417	SCREW, panh, 8–32 x 0.5	2		240485	Model 232135	1
27	114273	KNOB, potentiometer	1		240035	Model 232137	1
28	193056	LABEL, pressure adjust	1	95	114420	SCREW	4
29†	114284	CLAMP, power cord	1	96		WIRE, electrical, 5", (F), 18 AWG	1
30		CORD, power set	1		241546	Model 232135	1
	241547	Model 232135	1		240495	Model 232137	1
	240721	Model 232137	1	97	192838	LABEL, warning	2
31	114053	SCREW, trusshead, 8–32	2	99	114271	STRAP, hose	1
32	240318	KIT, shield, motor, U-695 includes 9, 31, & 37; 33 & 57	1	100†	238358	HOSE, whip, 3/16" x 3'	1
				101†	220955	SPRAY GUN, contractor manual 307614	1
33▲†	187784	LABEL, DANGER, French	2	102†	220794	HOSE, 1/4" x 50'	1
34	114406	SCREW, filh, 8–32 x 1.0	4	103▲	193072	LABEL, pressure	1
35	192617	LABEL, cover, front	1	105▲	192838	LABEL, WARNING, French	1
36	111612	ADAPTER, tube	1	107	114422	SCREW, pnhd	1
37	114052	NUT, self-retaining	2	108	240498	WIRE, ground	1
38	112612	CAP, hub	2	109†	193521	LABEL, caution (not shown)	1
39	112607	WHEEL, semi-pneumatic	2	110		LABEL, caution (not shown)	1
40	109570	WASHER, plain	2		192839	Model 232135	1
41	100069	BALL, thrust	1		189699	Model 232137	1
42	112759	PLUG, tube	2	111†	104984	TEE	1
43	192808	TUBE, suction	1	112†	102814	GUAGE	1
44	235004	STRAINER, 1/2 npsm	1	113†	100721	PLUG, pipe	1
45	104938	PACKING, o-ring	1	114	192849	LABEL, WARNING	1
46	192644	NIPPLE, long, 1/4 npt x 1/4 npsm	1	115	156971	NIPPLE, 1/4 npt x 1/4 npt	1
47	187624	HOSE, suction, swivel	1	116†	241337	FILTER, power inlet	1
48	240711	FILTER, fluid; manual 308249	1	117†	187962	GASKET	1
49	114026	CLIP, spring	1	118†	102410	SCREW	2
50	238345	HOSE, drain assy	1	119†	241545	WIRE, electrical	1
51	235014	ASSEMBLY, drain valve includes 55 and 56	1	120†	115098	RETAINER, cord	1
52	224807	VALVE, base	1	121†	111840	SCREW	2
53	111600	PIN, grooved	1				

▲ Extra Warning Labels available free

† Model 232135 only

‡ Model 232137

Complete Sprayer Parts

Model 232138, Series A

Model 232136, Series A

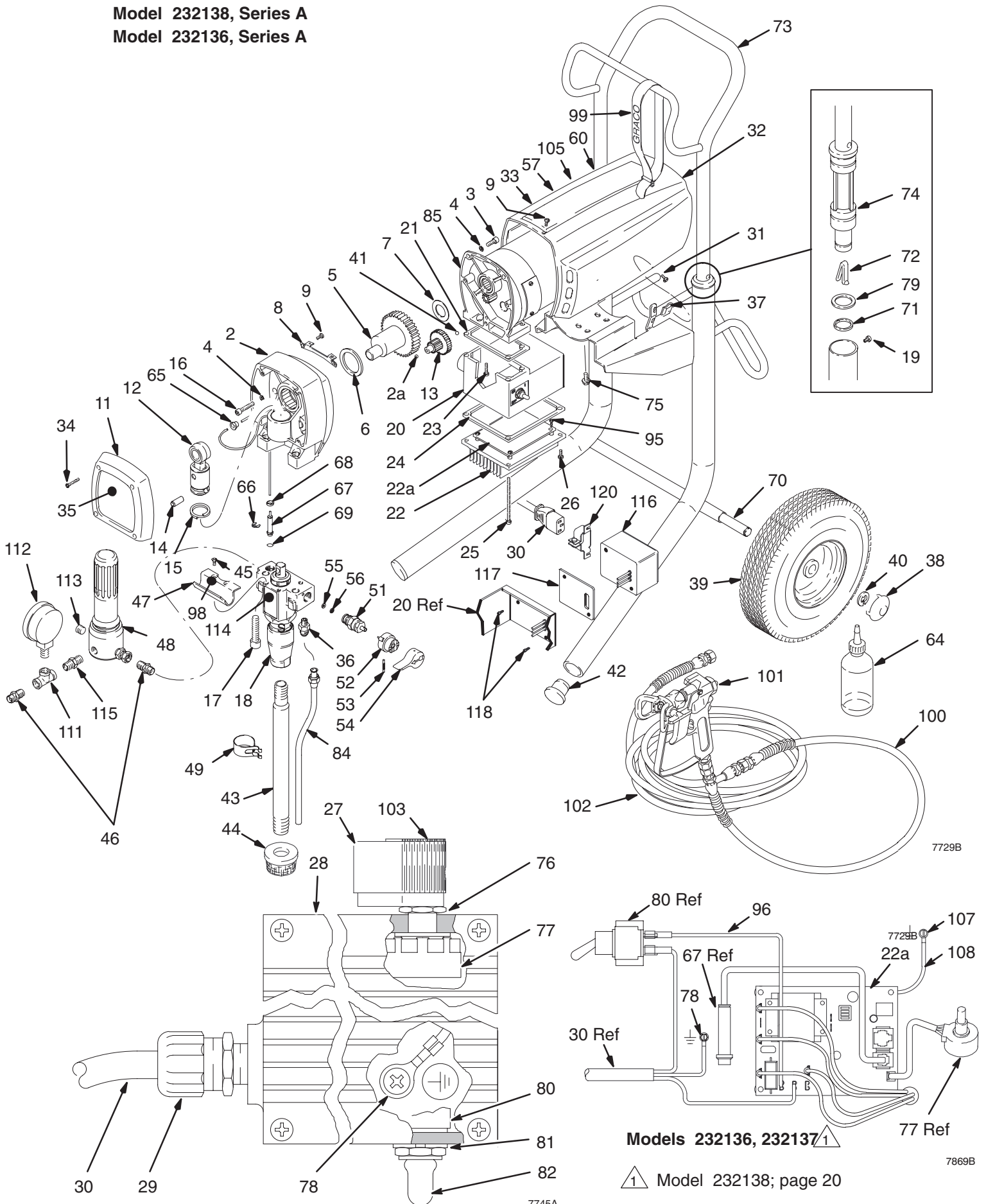

7729B

7729B

7869B

7745A

Pressure Control Box
(Bottom View)

Models 232136, 232137 ¹

¹ Model 232138; page 20

Complete Sprayer Parts

Model 232138, Series A; Model 232136, Series A

Ref. No.	Part No.	Description	Qty.	Ref. No.	Part No.	Description	Qty.
2	240057	KIT, housing, drive, U-695	1	57▲		LABEL, DANGER, English	
2a	100069	BALL, thrust	1		187791	Model 232138	2
3	101682	SCREW, sch, 1/4–20 x .625	2		189702	Model 232136	2
4	105510	LOCKWASHER, 1/4 hi-collar	5	60▲		LABEL, WARNING, elec shock	1
5	239979	CRANKSHAFT, U-695	1		187975	Model 232138	1
6	180131	BEARING, thrust, front	1		193520	Model 232136	1
7	107434	BEARING, thrust, rear	1	64	206994	LIQUID, throat seal	1
8	189270	BRACKET, shield	1	65	114296	GROMMET, cable	1
9	108865	SCREW, panh	5	66	112396	RING, external retaining	1
11	236366	KIT, cover, front, U-695	1	67	240514	TRANSDUCER, pressure control	1
12	240519	CONNECTING, rod assy	1	68	189269	SPACER, transducer	1
13	218364	GEAR, assy, 2nd stage	1	69	104319	PACKING, o-ring,PTFE ¹	1
14	176818	PIN, straight	1	70	240007	FRAME, cart, U-695	1
15	176817	SPRING, retaining	1	71	110243	RING, retaining, handle	2
16	103345	SCREW, sch, 1/4–20 x 1.25	3	72	111590	BUTTON, spring	2
17	111706	SCREW, mach, sch, 7/16 x 1.75	2	73	239998	HANDLE, cart	1
18	239769	KIT, pump, displacement; Manual 308815	1	74	192027	SLEEVE, cart	2
19	109032	SCREW, 10–24 x 0.250	4	75	110997	SCREWS, 1/4–20 x .625	4
20		HOUSING, junction box		76	112382	NUT, shaft sealing	1
	194435	Model 232138	1	77	236352	POTENTIOMETER, pressure adj	1
	189105	Model 232136	1	78	110037	SCREW, sltd hex hd, 10–24 x .375	1
21	112158	GASKET, motor	1	79	183350	WASHER, flat	2
22	192844	HEAT SINK, does not include 22a	1	80		SWITCH, toggle	
22a		KIT, board, control, motor Manual 308816			111826	Model 232138	1
	240561	Model 232138	1	81	105658	Model 232136	1
	240168	Model 232136	1	82	105659	RING, locking	1
23	112379	SCREW, filh, 10–24 x 0.75	2	84	240017	BOOT, toggle	1
24	112159	GASKET, heatsink	1	85		TUBE, drain	1
25	112381	SCREW, panh, 10–24 x 3.5	2		240511	KIT, motor, electric, DC	1
26	114417	SCREW, panh, 8–32 x 0.5	2		240036	Model 232136	1
27	114273	KNOB, potentiometer	1	95	114420	SCREW	4
28	193056	LABEL, pressure adjust	1	96		WIRE, electrical, 5", (F), 18 AWG	
29†	114284	CLAMP, power cord	1		241546	Model 232138	1
30		CORD, power set	1		240495	Model 232136	1
	241547	Model 232138	1	98▲	192840	LABEL, WARNING, finger pinch	1
	240721	Model 232136	1	99	114271	STRAP, hose	1
31	114053	SCREW, trusshead, 8–32	2	100†	238358	HOSE, whip, 3/16" x 3'	1
32	240318	KIT, shield, motor, U-695 includes 9, 31, & 37; 33 & 57	1	101†	220955	SPRAY GUN, contractor Manual 307614	1
33▲	187784	LABEL, DANGER, French	2	102†	240794	HOSE, 1/4" x 50'	1
34	114406	SCREW, filh, 8–32 x 1.0	4	103▲	193072	LABEL, pressure	1
35	192617	LABEL, cover, front	1	105▲	192838	LABEL, WARNING, French	1
36	111612	ADAPTER, tube	1	107	114422	SCREW, pnhd	1
37	114052	NUT, self-retaining	2	108	240498	WIRE, ground	1
38	104811	CAP, hub	2	109‡	193521	LABEL, caution (not shown)	1
39	106062	WHEEL, semi-pneumatic	2	110		LABEL, caution (not shown)	
40	101242	RING, retaining, wheel	2		192839	Model 232138	1
41	100069	BALL, thrust	1		189699	Model 232136	1
42	108691	PLUG, tube	2	111‡	104984	TEE	1
43	192809	TUBE, suction	1	112‡	102814	GUAGE	1
44	187190	STRAINER	1	113‡	100721	PLUG, pipe	1
45	112777	SCREW, 8–32 x 38	2	114	192849	LABEL, WARNING	1
46	193718	NIPPLE, 1/4 npt x 1/4 npsm	2	115	156971	NIPPLE, 1/4 npt x 1/4 npt	1
47	190321	HANGER, pail	1	116‡	241337	FILTER, power inlet	1
48	240711	FILTER, fluid; Manual 308249	1	117‡	187962	GASKET	1
49	192648	CLIP, spring	1	118‡	102410	SCREW	2
51	235014	ASSY, drain valve; includes 55 and 56	1	119‡	241545	WIRE, electrical, 5 in., 14 AWG	1
52	224807	VALVE, base	1	120†	115098	RETAINER, cord	1
53	111600	PIN, grooved	1	121†	111840	SCREW	2
54	187625	HANDLE, drain valve	1				
55	111699	GASKET, seat valve	1				
56	187615	SEAT, valve, lapped	1				

▲ Extra Warning Labels available free
† Model 232138 only
‡ Model 232136

Graco Standard Warranty

Graco warrants all equipment referenced in this document which is manufactured by Graco and bearing its name to be free from defects in material and workmanship on the date of sale by an authorized Graco distributor to the original purchaser for use with the exception of any special, extended, or limited warranty published by Graco, Graco will, for a period of twelve months from the date of sale, repair or replace any part of the equipment determined by Graco to be defective. This warranty applies only when the equipment is installed, operated and maintained in accordance with Graco's written recommendations.

This warranty does not cover, and Graco shall not be liable for general wear and tear or any malfunction, damage or wear caused by faulty installation, misapplication, abrasion, corrosion, inadequate or improper maintenance, negligence, accident, tampering, or substitution of non-Graco component parts. Nor shall Graco be liable for malfunction, damage or wear caused by the incompatibility of Graco equipment with structures, accessories, equipment or materials not supplied by Graco, or the improper design, manufacture, installation, operation or maintenance of structures, accessories, equipment or materials not supplied by Graco.

This warranty is conditioned upon the prepaid return of the equipment claimed to be defective to an authorized Graco distributor for verification of the claimed defect. If the claimed defect is verified, Graco will repair or replace free of charge any defective parts. The equipment will be returned to the original purchaser transportation prepaid. If inspection of the equipment does not disclose a defect in material or workmanship, repairs will be made at a reasonable charge, which charges may include the costs of parts, labor and transportation.

THIS WARRANTY IS EXCLUSIVE, AND IS IN LIEU OF ANY OTHER WARRANTIES, EXPRESS OR IMPLIED, INCLUDING BUT NOT LIMITED TO WARRANTY OF MERCHANTABILITY OR WARRANTY OF FITNESS FOR A PARTICULAR PURPOSE.

Graco's sole obligation and buyer's sole remedy for any breach of warranty shall be as set forth above. The buyer agrees that other remedy (including, but not limited to, incidental or consequential damages for lost profits, lost sales, injury to person or property, or any other incidental or consequential loss) shall be available. Any action for breach of warranty must be brought within two (2) years of the date of sale.

GRACO MAKES NO WARRANTY, AND DISCLAIMS ALL IMPLIED WARRANTIES OF MERCHANTABILITY AND FITNESS FOR A PARTICULAR PURPOSE, IN CONNECTION WITH ACCESSORIES, EQUIPMENT, MATERIALS OR COMPONENTS SOLD BUT NOT MANUFACTURED BY GRACO. These items sold, but not manufactured by Graco (such as electric motors, switches, hose, etc.), are subject to the warranty, if any, of their manufacturer. Graco will provide purchaser with reasonable assistance in making any claim for breach of these warranties.

In no event will Graco be liable for indirect, incidental, special or consequential damages resulting from Graco supplying equipment hereunder, or the furnishing, performance, or use of any products or other goods sold hereto, whether due to a breach of contract, breach of warranty, the negligence of Graco, or otherwise.

FOR GRACO CANADA CUSTOMERS

The parties acknowledge that they have required that the present document, as well as all documents, notices and legal proceedings entered into, given or instituted pursuant hereto or relating directly or indirectly hereto, be drawn up in English. Les parties reconnaissent avoir convenu que la rédaction du présente document sera en Anglais, ainsi que tous documents, avis et procédures judiciaires exécutés, donnés ou intentés à la suite de ou en rapport, directement ou indirectement, avec les procédures concernées.

ADDITIONAL WARRANTY COVERAGE

Graco does provide extended warranty and wear warranty for products described in the "Graco Contractor Equipment Warranty Program".

Phone Number

TO PLACE AN ORDER, contact your Graco distributor, or call this number to identify the distributor closest to you:
1-800-690-2894 Toll Free

*All written and visual data contained in this document reflects the latest product information available at the time of publication.
Graco reserves the right to make changes at any time without notice.*

Sales Offices: Minneapolis, Detroit

Foreign Offices: Belgium, England, Korea, France, Germany, Hong Kong, Japan

GRACO INC. P.O. BOX 1441 MINNEAPOLIS, MN 55440-1441

<http://www.graco.com>

PRINTED IN USA 308852 May 1998, Revised March 1999