

HEAVY-DUTY STAINLESS STEEL Drum Agitators

308609Y
EN

Heavy-duty, back-gearred agitator for mixing and maintaining suspension of industrial coatings stored in 55-gallon drums. For professional use only.

100 psi (0.7 MPa, 7 bar) Maximum Working Pressure

See page 3 for model information and approvals.



Important Safety Instructions

Read all warnings and instructions in this manual before using the equipment. Save these instructions.

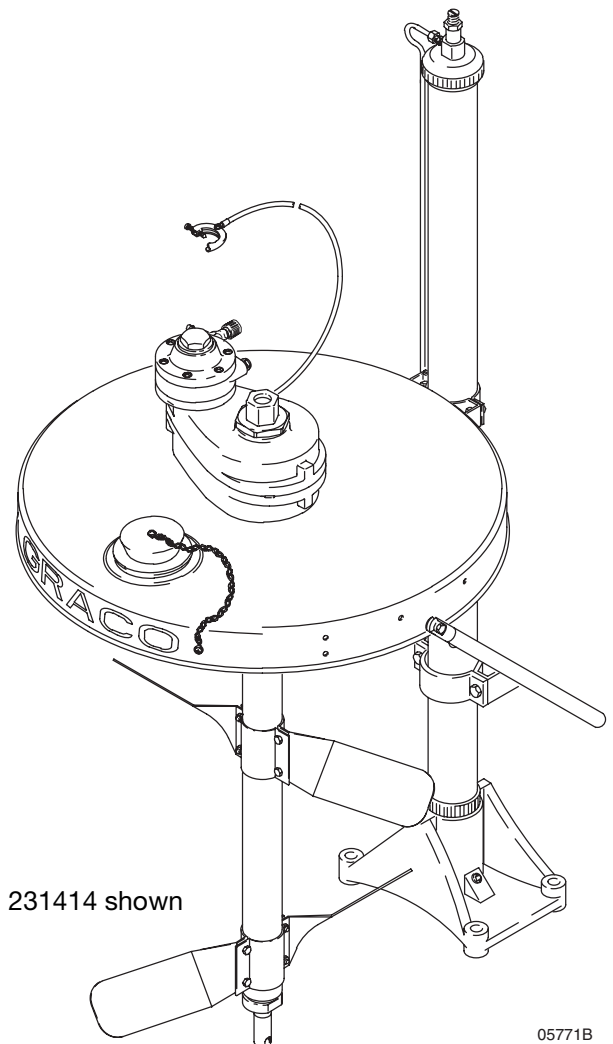





Model 231414 shown

05771B

Contents

Models	3	Service	13
Related Manuals	3	Service the Gear Reducer	13
Warnings	4	Parts	16
Installation	6	Heavy-Duty Stainless Steel Agitator, Model 238157	
Grounding	6	16	
Assemble and Position the Agitator	7	Heavy-Duty Stainless Steel Agitator with Siphon	
Install With or Without an Elevator	7	Kit, Model 240209	16
Install an In-Drum Heavy Duty Back Geared		Siphon Kit, Model 238250	16
Agitator	8	Heavy-Duty Stainless Steel Agitator, Drum	
Install the Siphon Kit	8	Mounted, Models 24C293 and 24C522. . . .	18
Return Tube Kit 238884 (Accessory)	9	Non-Siphon Agitator Package, Model 231413 .	20
Air Requirements	9	Technical Specifications	21
Air Line Accessories	9	Dimensions	22
Operation	10	Heavy-Duty Stainless Steel Agitator	22
Find the Proper Agitator Speed	10	Siphon Kit, Model 238250	22
Pressure Relief Procedure	10	Mounting Hole Layout	23
Shutdown	10	California Proposition 65	23
Maintenance	11	Graco Standard Warranty	24
Flush the Air Motor	11		
Lubricate the Air Motor	11		
Agitator Blades	11		
Clean the Agitator Shaft and Seal	12		
Clean an Agitator with a Siphon Kit	12		

Models









Part	Series	Description	Agency Approvals
238157	C	Back-Geared, Air-Powered Agitator	 II 1/2 G Ex h IIB T4 Ga/Gb CML 24ATEX6023X
24C293 24C522	B	Back-Geared, Drum Mounted, Air-Powered Agitator	
240209	C	Back-Geared, Air-Powered Siphon Agitator	
231413	A	Non-Siphon Agitator Package	 
231414	A	Siphon Agitator Package	
238250	A	Siphon Tube Kit	---

Related Manuals

Manuals in English	Description
306287	Elevators and Pump Supports Instructions-Parts List
308466	Stainless Steel, Passivated Drum Covers Instructions-Parts List
406358	Return Tube Kit (238884) Instructions
3A4792	Air-Driven Agitators Instructions

Warnings

The following warnings are for the setup, use, grounding, maintenance, and repair of this equipment. The exclamation point symbol alerts you to a general warning and the hazard symbols refer to procedure-specific risks. When these symbols appear in the body of this manual or on warning labels, refer back to these Warnings. Product-specific hazard symbols and warnings not covered in this section may appear throughout the body of this manual where applicable.

 <h2 style="margin: 0;">WARNING</h2>	
   	<p>FIRE AND EXPLOSION HAZARD</p> <p>Flammable fumes, such as solvent and paint fumes, in work area can ignite or explode. Paint or solvent flowing through the equipment can cause static sparking. To help prevent fire and explosion:</p> <ul style="list-style-type: none"> • Use equipment only in well ventilated area. • Eliminate all ignition sources; such as pilot lights, cigarettes, portable electric lamps, and plastic drop cloths (potential static arc). • Ground all equipment in the work area. See Grounding instructions. • Never spray or flush solvent at high pressure. • Keep work area free of debris, including solvent, rags, and gasoline. • Do not plug or unplug power cords, or turn power or light switches on or off when flammable fumes are present. • Use only grounded hoses. • Hold gun firmly to side of grounded pail when triggering into pail. Do not use pail liners unless they are antistatic or conductive. • Stop operation immediately if static sparking occurs or you feel a shock. Do not use equipment until you identify and correct the problem. • Keep a working fire extinguisher in the work area.
 	<p>MOVING PARTS HAZARD</p> <p>Moving parts can pinch, cut or amputate fingers and other body parts.</p> <ul style="list-style-type: none"> • Keep clear of moving parts. • Do not operate equipment with protective guards or covers removed. • Do not wear loose clothing, jewelry or long hair while operating equipment. • Equipment can start without warning. Before checking, moving, or servicing equipment, follow the Pressure Relief Procedure and disconnect all power sources.
	<p>SPECIAL CONDITIONS FOR SAFE USE</p> <ul style="list-style-type: none"> • Electrostatic charging hazard. Clean surfaces with a damp cloth and read instructions for additional techniques to mitigate risk of electrostatic discharge. • The Ambient Temperature Range of each agitator depends on the air motor included in the assembly. Refer to Models and Technical Specifications in Instruction manual for additional information.



WARNING



EQUIPMENT MISUSE HAZARD

Misuse can cause death or serious injury.



- Do not operate the unit when fatigued or under the influence of drugs or alcohol.
- Do not exceed the maximum working pressure or temperature rating of the lowest rated system component. See **Technical Specifications** in all equipment manuals.
- Use fluids and solvents that are compatible with equipment wetted parts. See **Technical Specifications** in all equipment manuals. Read fluid and solvent manufacturer's warnings. For complete information about your material, request Safety Data Sheets (SDSs) from distributor or retailer.
- Do not leave the work area while equipment is energized or under pressure.
- Turn off all equipment and follow the **Pressure Relief Procedure** when equipment is not in use.
- Check equipment daily. Repair or replace worn or damaged parts immediately with genuine manufacturer's replacement parts only.
- Do not alter or modify equipment. Alterations or modifications may void agency approvals and create safety hazards.
- Make sure all equipment is rated and approved for the environment in which you are using it.
- Use equipment only for its intended purpose. Call your distributor for information.
- Route hoses and cables away from traffic areas, sharp edges, moving parts, and hot surfaces.
- Do not kink or over bend hoses or use hoses to pull equipment.
- Keep children and animals away from work area.
- Comply with all applicable safety regulations.



TOXIC FLUID OR FUMES HAZARD

Toxic fluids or fumes can cause serious injury or death if splashed in the eyes or on skin, inhaled, or swallowed.

- Read Safety Data Sheets (SDSs) to know the specific hazards of the fluids you are using.
- Store hazardous fluid in approved containers, and dispose of it according to applicable guidelines.





PERSONAL PROTECTIVE EQUIPMENT

Wear appropriate protective equipment when in the work area to help prevent serious injury, including eye injury, hearing loss, inhalation of toxic fumes, and burns. Protective equipment includes but is not limited to:

- Protective eyewear, and hearing protection.
- Respirators, protective clothing, and gloves as recommended by the fluid and solvent manufacturer.

Installation

				
<p>To reduce the risk of fire and explosion, always maintain a minimum of 1 in. (25.4 mm) clearance between the rotating agitator parts and the container to prevent sparks from contact.</p>				

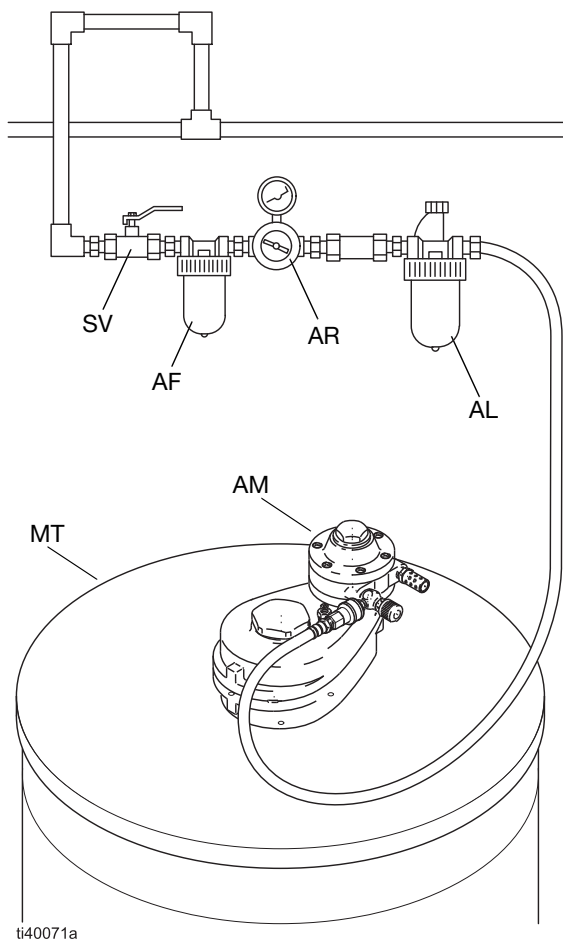





FIG. 1: Typical Installation

Key:

- SV: Bleed-type air shutoff valve
- AF: Air line filter
- AR: Air regulator and gauge
- AL: Air line lubricator
- AM: Agitator motor
- MT: Mix tank (reference only)

NOTE: Reference numbers and letters in parentheses refer to the callouts in the figures and in **Parts** on page 16.

Grounding

				
<p>The equipment must be grounded to reduce the risk of static sparking. Static sparking can cause fumes to ignite or explode. To reduce the risk of static sparking, all electrically conductive objects or devices in the spray area must be properly grounded.</p>				

Check your local electrical code for detailed grounding instructions for your area and type of equipment.

To ground the agitator, connect one end of the ground wire (A) to the ground connector (B) on the agitator. See FIG. 2. Connect the other end of the ground wire to a true earth ground.

For an additional ground wire and clamp, order part number 237569.

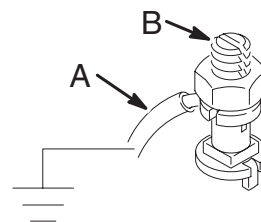

FIG. 2

Assemble and Position the Agitator

With an Elevator

Mount the drum cover as described in manual 306287. The elevator must be in the down position when you do any work on the elevator, agitator, or drum cover assembly. **Do not** go under the elevator when it is raised. Proceed to step 1 in **Install With or Without an Elevator**.

Without an Elevator

If your system does not have an elevator, you should install the Handles Kit to facilitate handling the drum cover and agitator. Two people are needed to safely lift and move the drum cover and agitator. To order the Handles Kit, order part number 237524.

Place two standard 55 U.S. gallon (45 Imperial gallon) barrels 14 in. (approximately 36 cm) apart, and center the drum cover on the barrels with the Graco logo centered and facing you, as shown in FIG. 3. Proceed to step 1 in **Install With or Without an Elevator**.

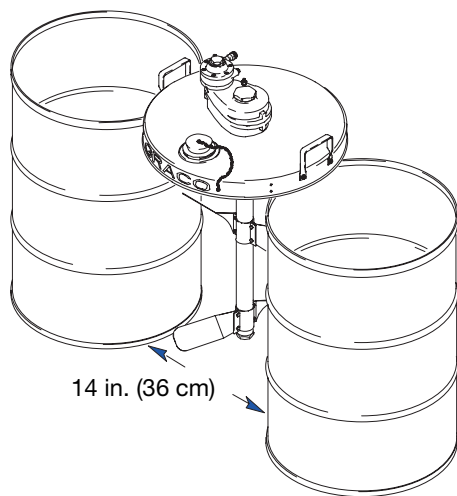

05734

FIG. 3: Assemble and Position Agitator Without an Elevator

Install With or Without an Elevator

1. Slide the agitator shaft through the large hole in the center of the drum cover (29).
2. Rotate the agitator so that the air motor is to the left of the shaft, as shown in FIG. 3, which will align the three tapped holes in the bottom of the agitator with the three through holes in the drum cover.
3. Thread the three hex head screws (25) up through the drum cover and into the agitator, and torque them to 75 in-lb (8.4 N•m).
4. Assemble one pair of agitator blades (28) so that the four through holes in the blade halves are lined up (see **Parts** on page 16 for blade orientation).
5. Push four cap screws (31) through the four holes in the blades, and start the lock nuts (32) onto the cap screws.
6. Slide the loose blade assembly up the shaft, and position it approximately 13 in. (33 cm) from the bottom of the shaft.
7. Tighten the four lock nuts (32) evenly to draw the blades together until they are tight on the shaft. Torque the locknuts to 50 to 55 in-lb (5.6 to 6.2 N•m). A gap will remain between the blade halves.
8. Repeat steps 4 and 5 with the second pair of agitator blades.
9. Position the second blade assembly near the bottom end of the shaft, but not on the bottom plug (20).
10. Rotate the lower blade assembly so that it is oriented 90 degrees relative to the upper blade assembly, and torque the lock nuts (32) to 50 to 55 in-lb (5.6 to 6.2 N•m). A gap will remain between the blade halves.

Install an In-Drum Heavy Duty Back Geared Agitator

1. Determine which size adaptor nut (20) is needed. The adaptor nuts in the kit are double-sided meaning that each adaptor nut will cover two agitator shaft sizes. Select the size you need by placing the adaptors onto the built in agitator shaft in the drum. The one you should use is the smallest one that will fit. There should only be a small amount of slop between the adaptor nut and the shaft.
2. Thread the adaptor into the gearbox output shaft (6) with the side you are going to use pointed down. Tighten it down using the wrench flats.
3. Place the threaded bung adaptor (34) onto the gearbox and align the bolt holes.
4. Thread the three bolts (28) into the gear box and torque to 10 ft-lbs (13.5 N•m).
5. Align the adaptor nut to engage the built-in shaft in the 55-gallon drum.
6. Slowly screw the unit onto the threads on the center bung fitting of the 55-gallon drum. Hand tighten to secure the unit. The unit should not easily unthread from the drum.

NOTE: To upgrade back-geared agitators with radial piston air motors for high viscosity (500cP to 3000 cP) material applications, see Retrofit Kit 25T862 or manual 3A4792.

Install the Siphon Kit

See the Siphon Kit, Model 238250, **Heavy-Duty Stainless Steel Agitator, Model 238157** on page 17.

1. Remove the top plug (5) and the bottom plug (20).
2. Replace the bottom plug (20) with the plain bearing (53), and tighten the bearing with a wrench.
3. Work the PTFE o-ring (54) onto the siphon tube retainer (51), and press it into the o-ring groove.
4. Replace the top plug (5) with the siphon tube retainer (51). Leave the retaining nut (52) on the siphon tube retainer, but make sure it is not tightened. Tighten the siphon tube retainer into the top of the agitator housing with a wrench.
5. Slide the siphon tube (50) down through the retaining nut (52), siphon tube retainer (51), and agitator shaft (6) until the siphon tube touches the bottom of the drum. Raise the siphon tube approximately 1/4 in. (approximately 6 mm) so that it does not touch the bottom of the drum. Hold the siphon tube at this height with one hand, and tighten the retaining nut with the other hand (hand tight is enough to hold the siphon tube in place).

NOTICE

Barrel Heights Vary.

Loosen the retaining nut on the siphon tube retainer before you raise the drum cover. If you do not loosen the retaining nut, the siphon tube may make contact with the bottom of the barrel when you lower the drum cover onto a new barrel, which could damage the siphon tube or the barrel.

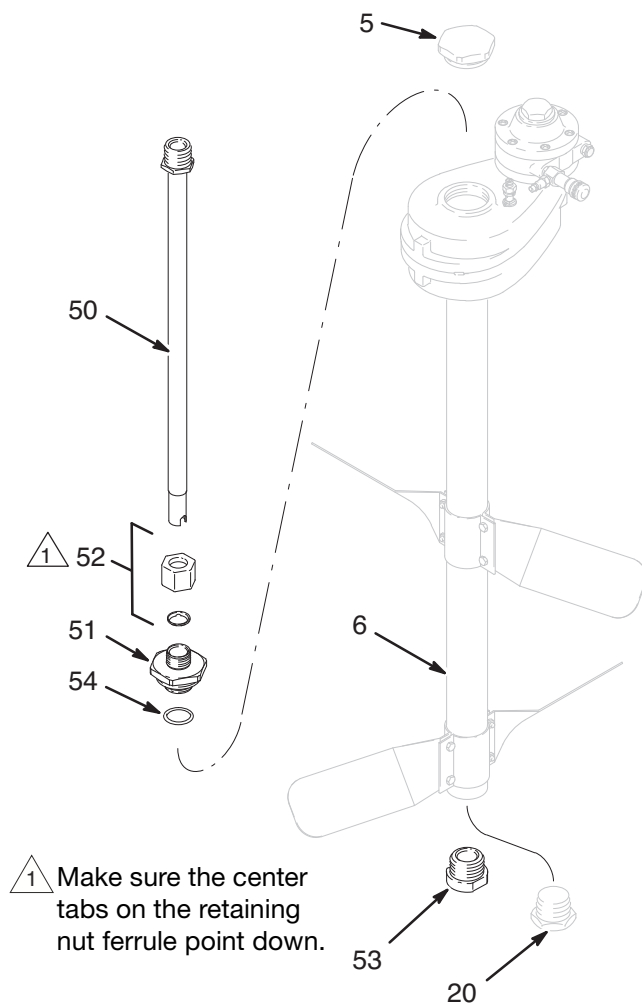

Fig. 4: Install the Siphon Kit

05736B

Return Tube Kit 238884 (Accessory)

Return Tube Kit 238884 is available as an accessory. The kit must be ordered separately. Refer to the sheet (406358) packed with the kit for installation instructions.

Air Requirements

For continuous use, the 3/4 HP (550 W) agitator air motor typically requires 3 to 4 cfm (0.09 to 0.12 m³/min) air supply.

Air Line Accessories

A bleed-type air shutoff valve (SV) is required; it isolates the air line components for servicing. The air shutoff valve should be installed in the supply line and can be used to stop and start the agitator. If the valve is used to stop and start the agitator, you do not need to set the agitator speed each time it is used.

Order air shutoff valves by the part numbers listed below:

- 110223** 1/4" npt(f) x 1/4" npt(f)
- 110224** 3/8" npt(f) x 3/8" npt(f)
- 113333** 3/8" npt(m) x 3/8" npt(f)

Optionally, attach a quick disconnect air line fitting and coupler. To order the 1/8" npt(m) air line fitting, order part number 169969. To order the coupler, order part number 208536.

Install an air line filter (AF) to remove harmful dirt and moisture from the air supply. To order an air line filter, order part number 106148 (3.8" npt, 20-micron element, 5 oz. Bowl, without gauge).

NOTICE
Not lubricating the air motor will cause air motor failure.

Downstream from the filter, install an air line lubricator (AL) for automatic air motor lubrication. Set the lubricator feed rate at 1 drop of oil per minute for high speed or continuous duty usage. Do not overfeed oil or exhaust air may become contaminated. To manually lubricate the air motor, see **Lubricate the Air Motor** on page 11. To order a 3/8" npt air line lubricator, order part number 214847.

Operation

Find the Proper Agitator Speed



Moving parts, such as an impeller blade, can cut or amputate fingers. To reduce the risk of serious injury, always shut off the agitator and disconnect the air line before checking or repairing the agitator.

NOTE: Attach ground wire before using agitator.

1. Fill the fluid supply container to about 3–4 inches (75–100 mm) above the agitator blade.
2. Start the agitator, and gradually increase the speed by turning the needle valve (14) until a vortex begins to form in the paint.
3. Reduce the speed slightly, then fill the fluid container. Use the lowest agitator speed needed for thorough agitation of the paint. Excessive agitator speed may cause the paint to foam.

NOTICE

Always maintain moderate agitator speed, which is approximately 50 rpm of the agitator blades. Excessive agitator speed may cause vibration, foaming of fluid, and increased wear on parts. Always agitate fluid thoroughly before supplying it to the dispensing equipment. Continue agitating fluid while the dispensing equipment is being supplied.

Pressure Relief Procedure



This equipment stays pressurized until pressure is manually relieved. To help prevent serious injury from splashing fluid and moving parts, follow the Pressure Relief Procedure before cleaning, checking, or servicing the equipment.

1. Close the bleed-type air shutoff valve (SV) to relieve pressure to the air motor.
2. Disconnect the air line.

Shutdown



To stop the agitator, close off the air supply with the needle valve (23) and close the bleed-type shut off valve (SV), or disconnect the air line coupler.

NOTICE





Keep the agitator upright. Do not lay it on its side or upside down, or liquid may flow down the shaft and into the gear reducer area causing damage.

Maintenance

Flush the Air Motor

				
---	---	--	--	--

Do not use kerosene or other flammable solvents to flush the air motor. Flushing with flammable solvents could cause fire or explosion and result in serious injury or property damage.

				
---	---	---	---	--

Hazardous fluids or toxic fumes can cause serious injury or death if splashed in the eyes or on the skin, swallowed, or inhaled. When flushing the air motor:

- Perform the procedure in a well ventilated area.
- Keep your face away from the exhaust port.
- Wear the appropriate protective clothing, gloves, eyewear, and respirator.

If the air motor is sluggish or inefficient, follow this procedure.

1. Disconnect the air line and muffler (22). See **Parts** on page 16.
2. Add several teaspoons of non-flammable solvent, or spray the solvent directly into the male quick-disconnect coupler (24).



NOTE: The recommended solvent for air motors and lubricated pumps is Gast® Flushing Solvent (Gast part number AH255 or AH255A) or Penetone Inhibisol® Safety Solvent.
3. Reconnect the air line, and slowly increase the air pressure until there is no trace of solvent in the exhaust air.
4. Reconnect the muffler (22).
5. Re-lubricate the motor with a squirt of lightweight oil into the male quick-disconnect coupler (24).

Lubricate the Air Motor

NOTICE
Not lubricating the air motor will cause air motor failure.

If an air line lubricator is not installed, the air motor must be manually lubricated every 8 hours. Lubricate the agitator air motor by placing 10–20 drops of SAE #10 light oil in the motor's air inlet. Oil must have an auto-ignition rating of 365°F (185°C) or greater. Run the agitator for about 30 seconds.

Agitator Blades

				
---	---	--	--	--

Materials can become electrostatically charged when stirred or blended. To prevent fire and explosion, ground equipment and do not allow material to build up on agitator. Dried material could allow static build up and interfere with grounding.

Regularly check the agitator for dried material buildup. Clean using a rag soaked in solvent that is compatible with the spray material and the surfaces being cleaned. Additionally, extra precautions need to be taken if using lower conductive materials (<1000 pS/m) such as:

- Avoid stirring/mixing at high speeds.
- Avoid insoluble mixtures.
- When possible, increase the material conductivity with additives.
- Use liquids with a high conductivity (>1000 pS/m).

Clean the Agitator Shaft and Seal

NOTICE

Keep the agitator upright. Do not lay it on its side or upside down, or liquid may flow down the shaft and into the gear reducer area causing damage.

If any material is on the shaft (6) within 1/2 in. (13 mm) of the housing (13), it must be removed to prevent damage to the bearing seal (14*). If the flexible lips on the bearing seal are torn or worn such that they do not make contact all the way around the shaft, the seal must be replaced. A worn seal may allow foreign material into the bearing and cause premature failure. See **Service the Gear Reducer** on page 13 for instructions on getting access to the seal and for the Bearing Replacement Kit part number.

Clean an Agitator with a Siphon Kit

The procedure for flushing and cleaning the siphon tube (50) and agitator shaft (6) is as follows:

1. Raise the agitator out of the drum.
2. Remove the plain bearing (53) from the agitator shaft (6), and clean it.
3. Detach any attachments from the siphon tube, and flush the siphon tube.
4. Loosen the retaining nut (52), and slowly lift the siphon tube (50) out of the agitator.
5. Clean the inside and outside of the siphon tube (50), flush the inside of the agitator shaft (6), and clean the agitator blades (28) and the outside of the shaft.
6. Reassemble the siphon tube by doing the reverse of steps 2 through 4.

Service

If the unit requires more than installation of a service kit, it is usually quickest and easiest to send the unit to the Graco distributor for repair or replacement.

NOTICE

Do not pry with a screwdriver. It will dent the surface of the plate and body, causing leaks. Use a puller tool, which will remove the end plate while maintaining the position of the shaft.

- If the vanes need replacing or foreign material is present in the motor chamber, an experienced mechanic may remove the end plate opposite the drive shaft end.
- New vanes should have the edges with cut corners (or the notched edges, if the vanes are reversible) pointing toward the bottom of the vane slot.

Service the Gear Reducer

You may want to have the Bearing Replacement Kit 238251 on hand before you begin this procedure. Bearing removal and installation instructions are included in the kit.

Disassemble

1. Relieve the pressure to the existing agitator. Follow the **Pressure Relief Procedure**, page 10.
2. If your agitator has a siphon kit, perform steps 2–4 in **Clean an Agitator with a Siphon Kit**, page 12.

If your agitator does not have a siphon kit, proceed to step 3 below.

3. Remove the agitator from the drum of material. Separate the agitator from the agitator shaft (if applicable):
 - a. For an in-drum agitator:
 - i. Unscrew the gearbox unit from the center bung fitting of the 55-gallon drum. Disengage and remove the unit from the built-in shaft in the 55-gallon drum.

- b. For an agitator without an elevator:
 - i. Remove and position the drum cover and agitator by following the instructions in **Assemble and Position the Agitator**, page 7, see **Without an Elevator**.
 - ii. Carefully separate the gearbox output shaft (6a) from the agitator shaft (6b) using the wrench flats on both shaft sections.
 - iii. Remove the agitator assembly from the drum cover by loosening the screws (25) that attach the gearbox to the drum cover.
- c. For an agitator with an elevator:
 - i. Raise the elevator (102), remove the drum and place it out of the way. Lower the elevator to the down position. The elevator must be in the down position when you do any work on the elevator, agitator, or drum cover assembly.
 - ii. Carefully separate the gearbox output shaft (6a) from the agitator shaft (6b) using the wrench flats on both shaft sections
 - iii. Remove the agitator assembly from the drum cover by loosening the screws (25) that attach the gearbox to the drum cover.
4. Remove the two short bolts (11) and the two long bolts (19) that hold the upper housing (8) and the lower housing (13) together. Carefully lifting straight up, lift the upper housing off of the lower housing.

Clean and Service

1. Clean any foreign material off of the outside of the upper and lower housings (8 and 13).

NOTE: Do not lose the two small thrust balls (4). One is in the upper housing (8), and one is in the lower housing (13).

2. Inspect the parts for any wear. If any of the parts are worn or damaged, replace them. The Bearing Replacement Kit contains replacement bearings and seals (items 2, 7, 9, 12, 14, and 15).

Reassemble

NOTE: See the **Parts** on page 16 for proper bearing and seal placement and orientation.

1. Reposition the lower housing (13) on the agitator shaft.

NOTICE

To prevent damage to the bearings and seals, avoid scraping them against the threaded agitator shaft while you are lowering the lower housing in place.

2. Thread the 50-mm nut (26) onto the agitator shaft by turning it clockwise, and tighten it hand tight.
3. Reposition the pinion/gear assembly (3, 16) in the lower housing, thread the large gear (10) onto the agitator shaft, and tighten the large gear hand tight.
4. Make sure the small thrust balls (4) are in place.
5. Reposition the pinion/gear assembly (3, 16) in the lower housing, thread the large gear (10) onto the agitator shaft, and tighten the large gear hand tight.

6. Carefully lowering it straight down, reposition the upper housing (8) on the lower housing (13).
7. Replace the two short bolts (11) and the two long bolts (19) that hold the upper housing (8) and the lower housing (13) together, and torque the bolts to 75 in-lb (8.5 N•m).
8. Reposition the agitator onto the drum by repeating the instructions for your agitator from step 3 in reverse order. For agitators with and without an elevator, torque the three hex head screws (25) to 75 in-lb (8.5 N•m) when installing.
9. If your agitator has a siphon kit, re-install it by doing the reverse of steps 2 through 4 in **Clean an Agitator with a Siphon Kit** on page 12.

Additional Agitator Service

If the unit requires more than installation of a bearing replacement kit or gear replacement, it may be advisable to send the unit to a Graco distributor for repair or replacement.

Parts

Heavy-Duty Stainless Steel Agitator, Model 238157

Includes items 1–34

Heavy-Duty Stainless Steel Agitator with Siphon Kit, Model 240209

Includes items 1–4, 6–19, 21–34, 50–54

Siphon Kit, Model 238250

Includes items 50–54

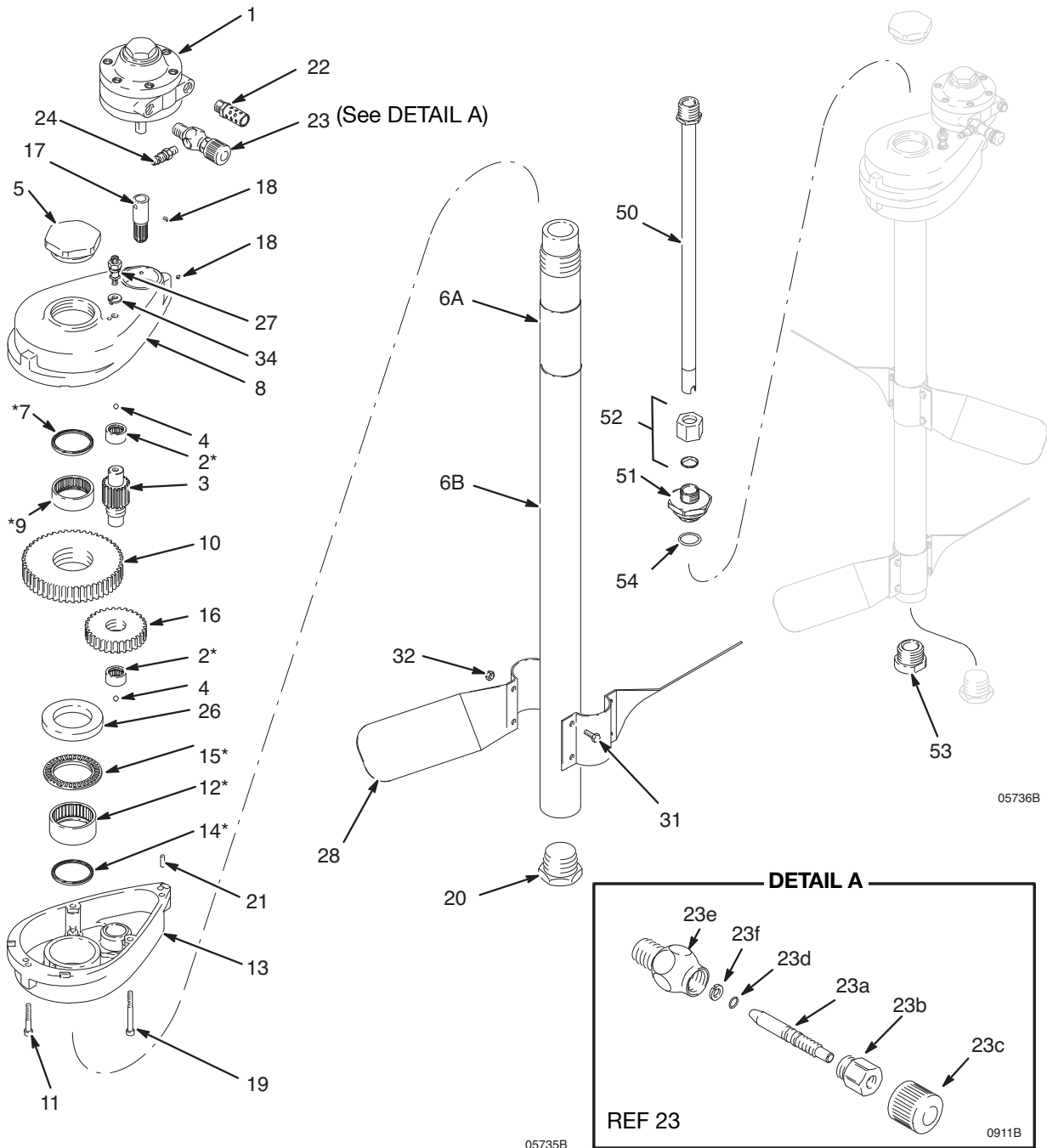

Heavy-Duty Stainless Steel Agitator, Model 238157

Includes items 1–34

Heavy-Duty Stainless Steel Agitator with Siphon Kit, Model 240209

Includes items 1–4, 6–19, 21–34, 50–54

Ref.	Part	Description	Qty.	Ref.	Part	Description	Qty.
1†	101140	AIR MOTOR	1	23e	165722	BODY, valve	1
2*	191004	BEARING, needle; 3/4"	2	23f	166531	WASHER	1
3	190988	GEAR, pinion #2	1	24	169969	FITTING, air line, male	1
4	100069	BALL, thrust	2	25	113358	SCREW, hex head; for mounting to drum cover (see page 23)	3
5	191003	PLUG, top	1	26	190976	NUT; 50 mm	1
6	24D311	KIT, agitator shaft <i>Includes items 6a and 6b</i>	1	27	104029	LUG, grounding	1
6a	16A519	SHAFT, agitator	1	28	190985	BLADE, agitator	4
6b	16C238	SHAFT, agitator	1	30s	17P806	KIT, safety tag (not shown)	1
7*	113363	SEAL, bearing	1	31	113413	SCREW, cap	8
8	194389	HOUSING, upper	1	32	113414	NUT, lock	8
9*	190980	BEARING, needle, 45 mm	1	34	104582	WASHER, tab	1
10	190989	GEAR #2	1	† <i>Air Motor Repair Kit, part number 207335, is available.</i>			
11	113357	SCREW, cap, socket head	2	* <i>Included in Bearing Replacement Kit 238251.</i>			
12*	190978	BEARING, needle, 50 mm	1	s <i>Replacement safety labels, tags, and cards are available at no cost.</i>			
13	194390	HOUSING, lower	1	NOTE: Part number 24C821 Agitator Drive Kit is available. The kit includes all of the above parts except items 6b, 20, 28, 31, and 32.			
14*	113359	SEAL, bearing	1	Siphon Kit, Model 238250			
15*	190979	BEARING, needle, thrust; 50 mm	1	(includes items 50–54)			
16	190987	GEAR #1	1	Ref No.	Part No.	Description	Qty
17	190986	GEAR, pinion #1	1	50	238161	TUBE, siphon	1
18	108161	SET SCREW, cup pt; SST	3	51	190998	RETAINER, siphon tube	1
19	113356	SCREW, cap, socket head	2	52	190999	NUT, retaining	1
20	191002	PLUG, bottom	1	53	191000	BEARING, plain	1
21	105489	PIN, dowel	2	54	164557	O-RING; PTFE	1
22	113779	MUFFLER	1				
23	206264	VALVE, needle <i>Includes items 23a to 23f</i>	1				
23a	166529	VALVE, needle	1				
23b	166532	NUT, packing	1				
23c	164698	KNOB, adjusting	1				
23d	157628	O-RING, packing	1				

Heavy-Duty Stainless Steel Agitator, Drum Mounted, Models 24C293 and 24C522

For drums with built-in shaft and blades

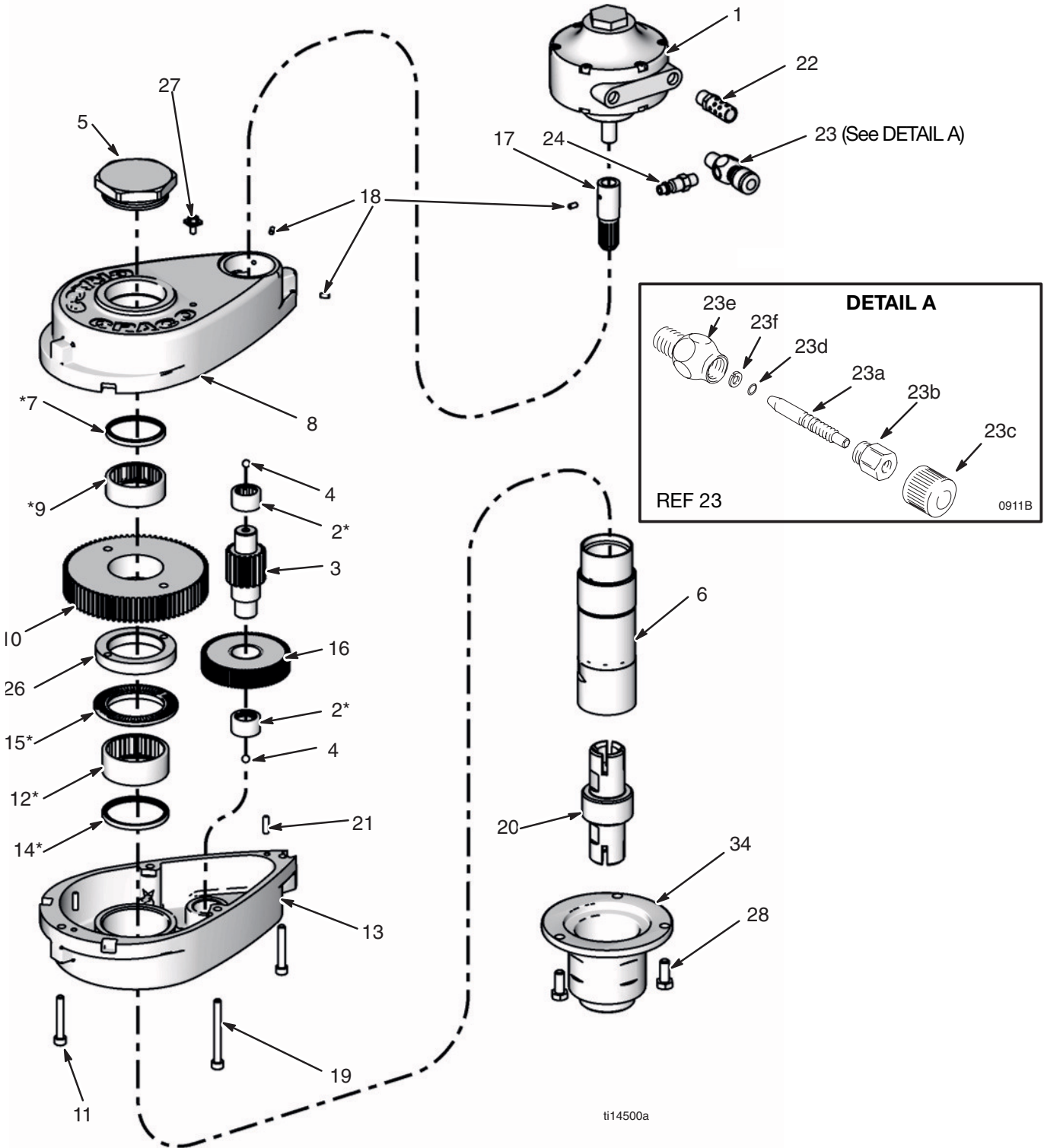

Heavy-Duty Stainless Steel Agitator, Drum Mounted, Models 24C293 and 24C522

Ref.	Part	Description	Qty	Ref.	Part	Description	Qty
1†	101140	AIR MOTOR	1	23	206264	VALVE, needle	
2	191004	BEARING, needle; 3/4"	2			<i>Includes items 23a to 23f</i>	1
3	190988	GEAR, pinion #2	1	23a	166529	VALVE, needle	1
4	100069	BALL, thrust	2	23b	166532	NUT, packing	1
5	191003	PLUG, top	1	23c	164698	KNOB, adjusting	1
6	16A519	SHAFT, agitator	1	23d	157628	O-RING, packing	1
7*	113363	SEAL, bearing	1	23e	165722	BODY, valve	1
8	194389	HOUSING, upper	1	23f	166531	WASHER	1
9*	190980	BEARING, needle, 45mm	1	24	169969	FITTING, air line, male	1
10	190989	GEAR #2	1	25	113358	SCREW, hex head; for mounting to drum cover (see page 23)	3
11	113357	SCREW, cap, socket head	2	26	190976	NUT, 50 mm	1
12*	190978	BEARING, needle, 50 mm	1	27	116343	SCREW, grounding	1
13	194390	HOUSING, lower	1	28	113358	SCREW, cap, hex	3
14*	113359	SEAL, bearing	1	30s	17P806	KIT, safety tag (not shown)	1
15*	190979	BEARING, needle, thrust; 50 mm	1	34©	16A521	HOUSING, adapter (for 24C293)	1
16	190987	GEAR #1	1	©	16A754	HOUSING, adapter (for 24C522)	1
17	190986	GEAR, pinion #1	1				
18	108161	SET SCREW, cup pt; SST	3	†	<i>Air Motor Repair Kit, part number 207335, is available.</i>		
19	113356	SCREW, cap, socket head	2				
20©	16H554	ADAPTER, nut, double-sided (7/16 and 3/8)	1	*	<i>Included in Bearing Replacement Kit 238251</i>		
	16H555	ADAPTER, nut (1/2 and 5/8)	1	©	<i>Included in Adapter Kit, 24D588</i>		
21	105489	PIN, dowel	2	s	<i>Replacement safety labels, tags, and cards are available at no cost.</i>		
22	113779	MUFFLER	1				

NOTE: Part number 24C821 Agitator Drive Kit is available. The kit includes all of the above parts except items 20 and 34.

Non-Siphon Agitator Package, Model 231413

Siphon Agitator Package, Model 231414 (shown)

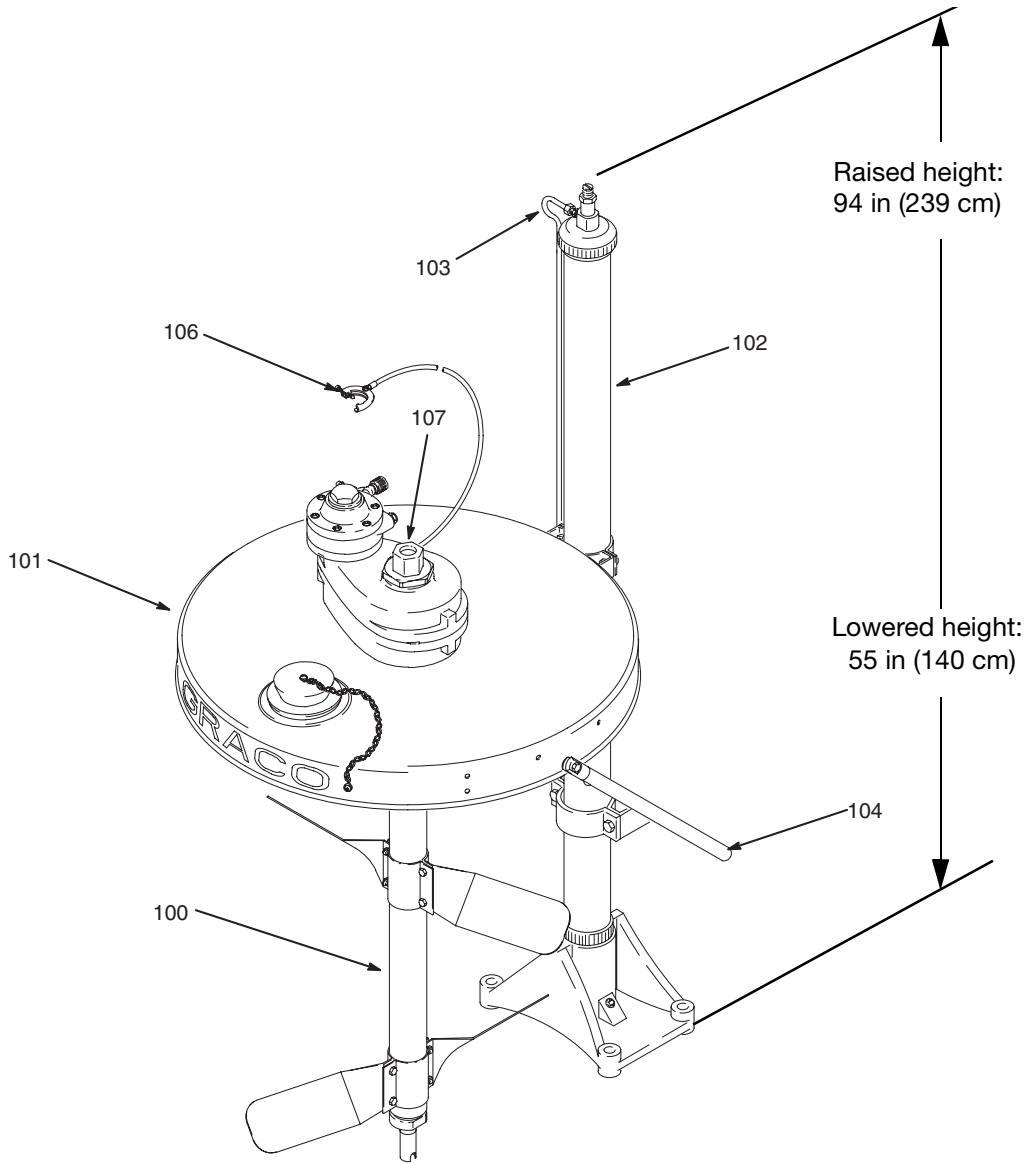

05771B

Ref.	Part	Description	Qty.	Ref.	Part	Description	Qty.
100	238157	AGITATOR: see page 16 for parts	1	104	237578	COVER SUPPORT KIT; see manual 306287	1
101	238283	COVER, sst; see manual 308466	1	105	238425	DESIGNATION PLATE KIT; Model 231413 (not shown)	1
102	204385	ELEVATOR; see manual 306287	1		238426	DESIGNATION PLATE KIT; Model 231414 (not shown)	1
103	237579	AIR CONTROL KIT; see manual 306287	1	106	237569	GROUND WIRE AND CLAMP	1
				107	238250	SIPHON KIT; Model 231414 only; see page 16 for parts	1

Technical Specifications

Heavy-Duty Stainless Steel Drum Agitators		
	US	Metric
Maximum working pressure	100 psi	0.7 MPa, 7 bar
Motor power rating at 1200 rpm (shaft at 50 rpm), using 12 cfm (0.34 m ³ /min)	0.25 hp	186 W
Maximum recommended shaft rpm	100	
Gear reducer ratio	24:1	
Ambient operating temperature range	+33.8°F < Ta < +104°F	+1°C < Ta < +40°C
Air inlet	Mates with 1/4-in. npt(f) quick-disconnect, part number 208536	
Siphon tube I.D.	3/4 in.	19 mm
Maximum flow at 100 cps	12 gpm	45.5 lpm
Maximum flow at 1000 cps	1.2 gpm	4.5 lpm
Air consumption	3 to 30 scfm	0.08 to 0.85 m ³ /min
Measurements		
Height		
From top of air motor to end of agitator shaft (no nut)	38 in.	965 mm
From top of air motor to end of siphon tube (no fittings)	43 in.	1092 mm
Span of agitator blades	20 in.	508 mm
Width of agitator blades	3 in.	76 mm
Noise (dBa)		
† Typical operating conditions		
Sound power	77.3 dBa	
Sound pressure	63.8 dBa	
‡ Maximum noise conditions		
Sound power	86.4 dBa	
Sound pressure	72.9 dBa	
<i>Sound power measured per ISO-3744-1981.</i>		
† 50 rpm (shaft) agitating 300 cps water-base material.		
‡ 100 rpm (shaft) agitating an empty container.		
Materials of Construction		
Wetted materials	304 SST, 304/304L SST, acetal, A/F, nylon, PTFE	
Weight		
All models	25.8 lb	11.7 kg
Reference Information		
Maximum storage time (varies with conditions)	10 years	
Maximum lifetime (varies with operating conditions and maintenance)	10 years	
Power Efficiency Factor (varies based on configuration, operating parameters, and material)	0.1 HP/SCFM air consumed with motor at 500 rpm	2.7 W/Liter air consumed with motor at 500 rpm
Notes		
Gast® is a registered trademark of Gast Manufacturing.		
Inhibisol® is a registered trademark of Penetone Corp.		

Dimensions

Heavy-Duty Stainless Steel Agitator

Model 238157 (shown)

 Height of Model 240209 is the same as the Siphon Kit (see right).

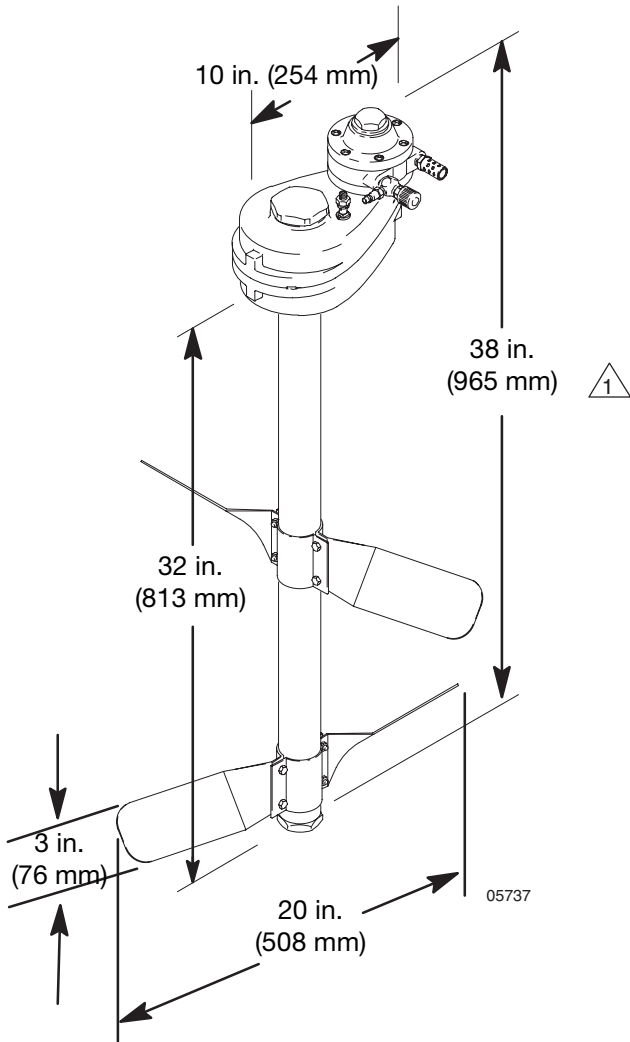

Siphon Kit, Model 238250

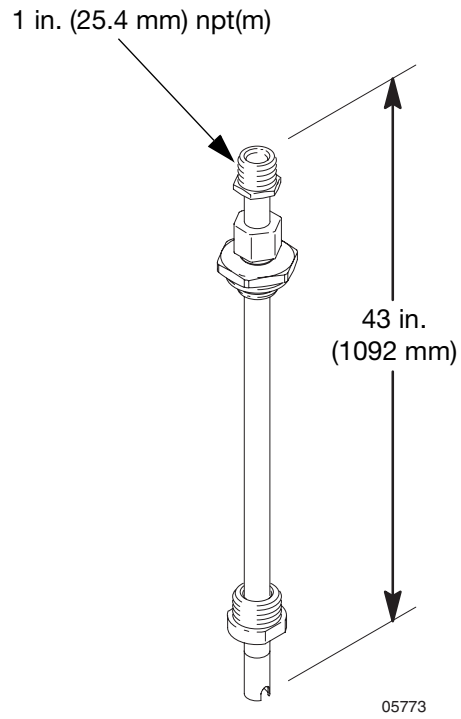

Mounting Hole Layout

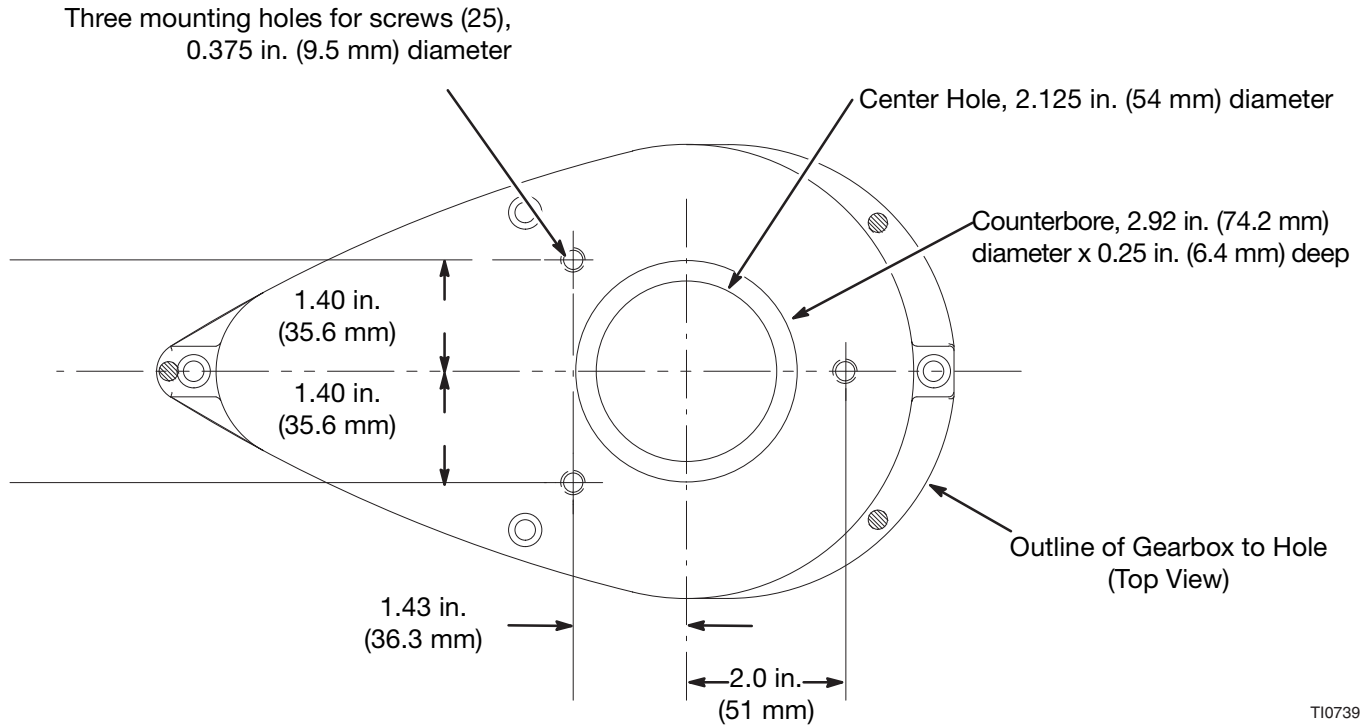

California Proposition 65

CALIFORNIA RESIDENTS

⚠ WARNING: Cancer and reproductive harm – www.P65warnings.ca.gov.

Graco Standard Warranty

Graco warrants all equipment referenced in this document which is manufactured by Graco and bearing its name to be free from defects in material and workmanship on the date of sale to the original purchaser for use. With the exception of any special, extended, or limited warranty published by Graco, Graco will, for a period of twelve months from the date of sale, repair or replace any part of the equipment determined by Graco to be defective. This warranty applies only when the equipment is installed, operated and maintained in accordance with Graco's written recommendations.

This warranty does not cover, and Graco shall not be liable for general wear and tear, or any malfunction, damage or wear caused by faulty installation, misapplication, abrasion, corrosion, inadequate or improper maintenance, negligence, accident, tampering, or substitution of non-Graco component parts. Nor shall Graco be liable for malfunction, damage or wear caused by the incompatibility of Graco equipment with structures, accessories, equipment or materials not supplied by Graco, or the improper design, manufacture, installation, operation or maintenance of structures, accessories, equipment or materials not supplied by Graco.

This warranty is conditioned upon the prepaid return of the equipment claimed to be defective to an authorized Graco distributor for verification of the claimed defect. If the claimed defect is verified, Graco will repair or replace free of charge any defective parts. The equipment will be returned to the original purchaser transportation prepaid. If inspection of the equipment does not disclose any defect in material or workmanship, repairs will be made at a reasonable charge, which charges may include the costs of parts, labor, and transportation.

THIS WARRANTY IS EXCLUSIVE, AND IS IN LIEU OF ANY OTHER WARRANTIES, EXPRESS OR IMPLIED, INCLUDING BUT NOT LIMITED TO WARRANTY OF MERCHANTABILITY OR WARRANTY OF FITNESS FOR A PARTICULAR PURPOSE.

Graco's sole obligation and buyer's sole remedy for any breach of warranty shall be as set forth above. The buyer agrees that no other remedy (including, but not limited to, incidental or consequential damages for lost profits, lost sales, injury to person or property, or any other incidental or consequential loss) shall be available. Any action for breach of warranty must be brought within two (2) years of the date of sale.

GRACO MAKES NO WARRANTY, AND DISCLAIMS ALL IMPLIED WARRANTIES OF MERCHANTABILITY AND FITNESS FOR A PARTICULAR PURPOSE, IN CONNECTION WITH ACCESSORIES, EQUIPMENT, MATERIALS OR COMPONENTS SOLD BUT NOT MANUFACTURED BY GRACO. These items sold, but not manufactured by Graco (such as electric motors, switches, hose, etc.), are subject to the warranty, if any, of their manufacturer. Graco will provide purchaser with reasonable assistance in making any claim for breach of these warranties.

In no event will Graco be liable for indirect, incidental, special or consequential damages resulting from Graco supplying equipment hereunder, or the furnishing, performance, or use of any products or other goods sold hereto, whether due to a breach of contract, breach of warranty, the negligence of Graco, or otherwise.

FOR GRACO CANADA CUSTOMERS

The Parties acknowledge that they have required that the present document, as well as all documents, notices and legal proceedings entered into, given or instituted pursuant hereto or relating directly or indirectly hereto, be drawn up in English. Les parties reconnaissent avoir convenu que la rédaction du présente document sera en Anglais, ainsi que tous documents, avis et procédures judiciaires exécutés, donnés ou intentés, à la suite de ou en rapport, directement ou indirectement, avec les procédures concernées.

Graco Information

For the latest information about Graco products, visit www.graco.com.

For patent information, see www.graco.com/patents.

TO PLACE AN ORDER, contact your Graco distributor or call to identify the nearest distributor.

Phone: 612-623-6921 **or Toll Free:** 1-800-328-0211, **Fax:** 612-378-3505

All written and visual data contained in this document reflects the latest product information available at the time of publication. Graco reserves the right to make changes at any time without notice.

Original instructions. This manual contains English. MM 308609

Graco Headquarters: Minneapolis

International Offices: Belgium, China, Japan, Korea

GRACO INC. AND SUBSIDIARIES • P.O. BOX 1441 • MINNEAPOLIS MN 55440-1441 • USA
Copyright 1995, Graco Inc. All Graco manufacturing locations are registered to ISO 9001.

www.graco.com
Revision Y, February 2024