

50:1 Ratio Fire-Ball[®] Lubrication Pump

307878ZAD
EN

Portable units for heavy grease. For professional use only.

See page 2 for model information, including maximum working pressure and approvals.



Important Safety Instructions

Read all warnings and instructions in this manual. Save these instructions.



These systems are designed to be used only in pumping non-corrosive and non-abrasive lubricants and grease. Any other use of the system can cause unsafe operating conditions and result in component rupture, fire, or explosion which can cause serious injury, including fluid injection.

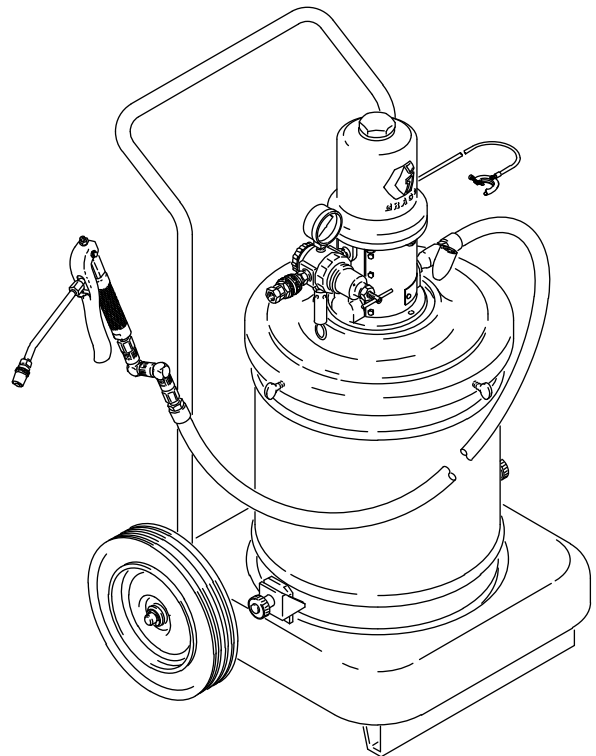

Model 240883 shown



Contents

Models 2

Warnings 3

Installation 5

 Grounding 5

 Models 225773, 225827, 240883, 240884, and 245695 5

 Models 225006, 225026, 240880, 240881, and 245696 6

 Models 222069, 240885, 245694 and 25C688 .. 7

 Models 222245 and 240882 7

 Models 226012 and 240886 8

 Typical Installation 9

 Air Line and Accessories 10

Operation 10

 Pressure Relief Procedure 10

 Start-up: Single or Multiple Pump Systems ... 10

Parts 12

Technical Data 17

 California Proposition 65 17

Graco Standard Warranty 18



Models

Part No.	Maximum Working Pressure psi (MPa, bar)	Size	Base Type*	Dispense Kit	Cover	Inductor	Follow Plate	Pail	CE Installation Kit 240831
225006	5000 (35, 350)	120 lb	Portable	✓	✓		✓		
240880 †		120 lb	Portable	✓	✓		✓		✓
25C688		120 lb	-	✓	✓		✓		✓
225026		120 lb	2-wheel truck	✓	✓		✓		
245696		120 lb	2-wheel truck	✓	✓		✓		
240881 †		120 lb	2-wheel truck	✓	✓		✓		✓
222245		120 lb	2-wheel truck	✓	✓		✓		
240882 †		120 lb	2-wheel truck	✓	✓		✓		✓
225773		35 to 50 lb	2-wheel truck	✓	✓			✓	
245695		35 to 50 lb	2-wheel truck	✓	✓			✓	
240883 †		35 to 50 lb	2-wheel truck	✓	✓			✓	✓
225827		35 to 50 lb	-	✓	✓			✓	
240884 †		35 to 50 lb	-	✓	✓			✓	✓
222069		25 to 50 lb	-	✓	✓		✓		
245694		25 to 50 lb	-	✓	✓		✓		
240885 †		25 to 50 lb	-	✓	✓		✓		✓
226012		50 lb	2-wheel truck	✓		✓			
240886 †		50 lb	2-wheel truck	✓		✓			✓

† These models are CE Certified.

Warnings

The following warnings are for the setup, use, grounding, maintenance, and repair of this equipment. The exclamation point symbol alerts you to a general warning and the hazard symbols refer to procedure-specific risks. When these symbols appear in the body of this manual or on warning labels, refer back to these Warnings. Product-specific hazard symbols and warnings not covered in this section may appear throughout the body of this manual where applicable.

 WARNING	
	<p>FIRE AND EXPLOSION HAZARD</p> <p>When flammable fluids are present in the work area, such as gasoline and windshield wiper fluid, be aware that flammable fumes can ignite or explode. To help prevent fire and explosion:</p> <ul style="list-style-type: none"> • Use equipment only in well ventilated area. • Eliminate all ignition sources, such as cigarettes and portable electric lamps. • Keep work area free of debris, including rags and spilled or open containers of solvent and gasoline. • Do not plug or unplug power cords or turn lights on or off when flammable fumes are present. • Ground all equipment in the work area. • Use only grounded hoses. • Stop operation immediately if static sparking occurs or you feel a shock. Do not use equipment until you identify and correct the problem. • Keep a working fire extinguisher in the work area.
	<p>EQUIPMENT MISUSE HAZARD</p> <p>Misuse can cause death or serious injury.</p> <ul style="list-style-type: none"> • Do not operate the unit when fatigued or under the influence of drugs or alcohol. • Do not exceed the maximum working pressure or temperature rating of the lowest rated system component. See Technical Data in all equipment manuals. • Use fluids and solvents that are compatible with equipment wetted parts. See Technical Data in all equipment manuals. Read fluid and solvent manufacturer's warnings. For complete information about your material, request MSDS from distributor or retailer. • Do not leave the work area while equipment is energized or under pressure. • Turn off all equipment and follow the Pressure Relief Procedure when equipment is not in use. • Check equipment daily. Repair or replace worn or damaged parts immediately with genuine manufacturer's replacement parts only. • Do not alter or modify equipment. Alterations or modifications may void agency approvals and create safety hazards. • Make sure all equipment is rated and approved for the environment in which you are using it. • Use equipment only for its intended purpose. Call your distributor for information. • Route hoses and cables away from traffic areas, sharp edges, moving parts, and hot surfaces. • Do not kink or over bend hoses or use hoses to pull equipment. • Keep children and animals away from work area. • Comply with all applicable safety regulations.

 **WARNING**



SKIN INJECTION HAZARD

High-pressure fluid from dispensing device, hose leaks, or ruptured components will pierce skin. This may look like just a cut, but it is a serious injury that can result in amputation. **Get immediate surgical treatment.**



- Do not point dispensing device at anyone or at any part of the body.
- Do not put your hand over the fluid outlet.
- Do not stop or deflect leaks with your hand, body, glove, or rag.
- Follow the **Pressure Relief Procedure** when you stop dispensing and before cleaning, checking, or servicing equipment.
- Tighten all fluid connections before operating the equipment.
- Check hoses and couplings daily. Replace worn or damaged parts immediately.



TOXIC FLUID OR FUMES HAZARD

Toxic fluids or fumes can cause serious injury or death if splashed in the eyes or on skin, inhaled, or swallowed.

- Read MSDSs to know the specific hazards of the fluids you are using.
- Store hazardous fluid in approved containers, and dispose of it according to applicable guidelines.
- Always wear chemically impermeable gloves when spraying, dispensing, or cleaning equipment.

Installation

Grounding

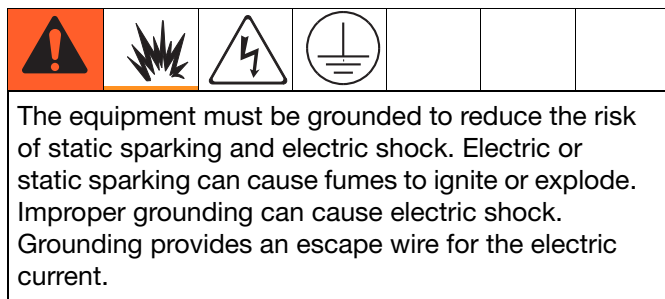

Ground all of this equipment:

- Pump: Use a ground wire and clamp as shown in FIG. 1. Remove the ground screw (Z) and insert through the eye of the ring terminal at end of ground wire (Y). Fasten the screw back onto the pump and tighten securely. Connect the other end of the ground wire to a true earth ground. To order a ground wire and clamp, order P/N 222011.

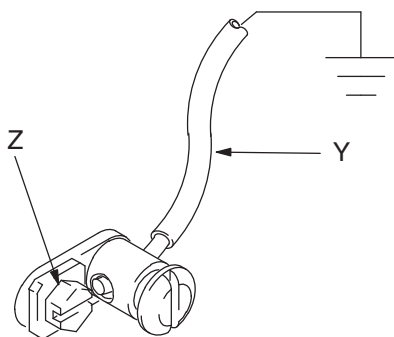

FIG. 1

- Air and fluid hoses: Use only grounded hoses.
- Air compressor: Follow manufacturer's recommendations.
- Fluid supply container: Follow the local code.
- To maintain ground continuity when flushing or relieving pressure, always hold a metal part of the gun firmly to the side of a grounded metal waste container, then trigger the gun.

Models 225773, 225827, 240883, 240884, and 245695

Refer to FIG. 2 for the following instructions.

1. **Models 225773, 240883, and 245695 only:**
Assemble the truck as shown in the parts drawing on page 13. Secure the truck pail (5) to the truck base with the pointed hold-down clamps (3c) and thumb nuts (3d).
2. **Models 225827 and 240884 only:**
Remove the fluid outlet adapter included with the pump, and screw the holster (6) into the pump outlet, using thread sealant.
3. Remove the cover (4) from the pail of lubricant. Place the pail of lubricant into the truck pail.
4. Secure the cover (4) on the pail with three thumb-screws (A).
5. Insert the pump riser tube through the top of the cover (4). Lower the pump until it rests on the cover.
6. Assemble the gun (2b) and hose (2a), and connect the hose to the pump fluid outlet.
7. Connect the nipple (2d) to the pump air inlet or air regulator (7b) inlet, whichever is applicable.
8. Connect the quick-disconnect coupler (2c) to the air supply hose.

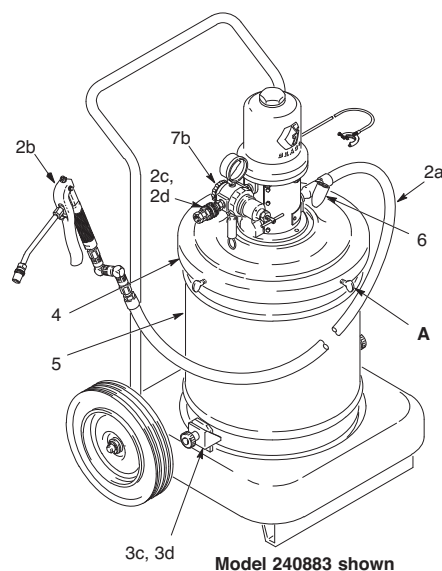

FIG. 2

Models 225006, 225026, 240880, 240881, and 245696

Refer to FIG. 3 for the following instructions.

1. **Models 225006 and 240880:** Assemble the base (3) as shown in the Parts Drawing on page 14.

Models 225026, 240881, and 245696: Assemble the truck (3) as shown in the Parts Drawing on page 13.

2. Remove the fluid outlet adapter included with the pump, and screw the holster (6) into the pump outlet, using thread sealant.
3. Place an open 120-lb (54.43 kg) drum of grease on mounting base or truck and secure it with the hold-down clamps.

For portable base models 225006 and 240880:
For steel drums use pointed end of bracket (3c). Position clamps above drum bead. Tighten bolts (3b).
For fiber drums reverse bracket (3c) to use flat end.

For truck model 225026, 245696 and 240881:
For steel drums: use pointed end of bracket (3c). Position clamp above drum bead. Tighten thumb nuts (3d).

4. Press the follow plate (5) down firmly onto the grease, and rotate it to eliminate air pockets and reduce channeling.
5. Insert the pump through the cover (4).
6. Slide the cover up far enough to let the pump pass easily through the follow plate grommet.
7. Secure the cover (4) on the drum with the thumb screws (A). It is not necessary to bolt the pump to the cover.
8. Assemble the gun (2b) and hose (2a), and connect the hose to the pump fluid outlet.
9. Connect the nipple (2d) to the pump air inlet or air regulator (7b) inlet, whichever is applicable.
10. Connect the quick-disconnect couple (2c) to the air supply hose.

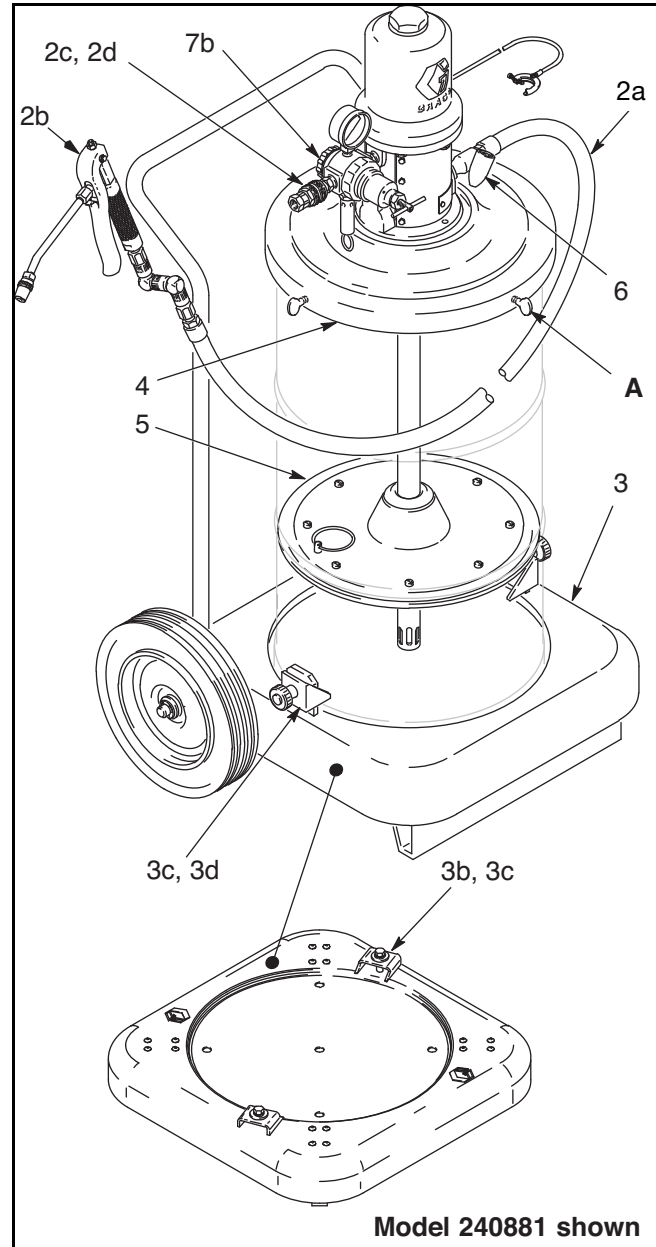

FIG. 3

Models 222069, 240885, 245694 and 25C688

Refer to FIG. 4 for the following instructions.

1. Remove the cover from the pail and scoop the lubricant from the center to the sides of the pail to make its surface concave.
2. Center the follow plate (5) in the pail opening. Press the plate firmly downward and rotate it over the lubricant surface to eliminate air pockets and prevent channeling.
3. Place the cover (3a) on the pail, and tighten the thumb screws (3f).
4. Assemble the gun (2b) and hose (2a), and connect the hose to the pump fluid outlet.
5. Connect the nipple (2d) to the pump air inlet or air regulator (7b) inlet, whichever is applicable.
6. Connect the quick-disconnect coupler (2c) to the air supply hose.

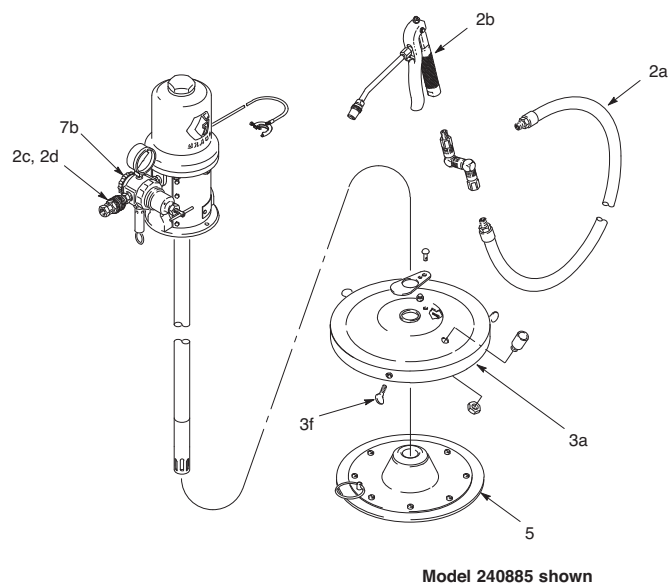

FIG. 4

Models 22245 and 240882

Refer to FIG. 5 for the following instructions.

1. Assemble the cart (6). Use only 2 of the 4 brackets (5d) supplied.
2. Install the rear positions of the drum shelf (6b).
3. Press the follow plate (4) down firmly onto the grease, and rotate it to eliminate any air pockets and reduce channeling. Insert the pump through the cover (3). Slide the cover up far enough to allow the pump to pass easily through the follow plate grommet and into the grease.
4. Using items 5a to 5d, secure the cover to the drum, and the drum to the cart. It is not necessary to bolt the pump to the cover.
5. Assemble the gun (2b) and hose (3a), and connect the hose to the pump fluid outlet.
6. Connect the quick-disconnect nipple (2d) to the pump air inlet or air regulator (7b) inlet, whichever is applicable.
7. Connect the quick-disconnect couple (2c) to the air supply hose.

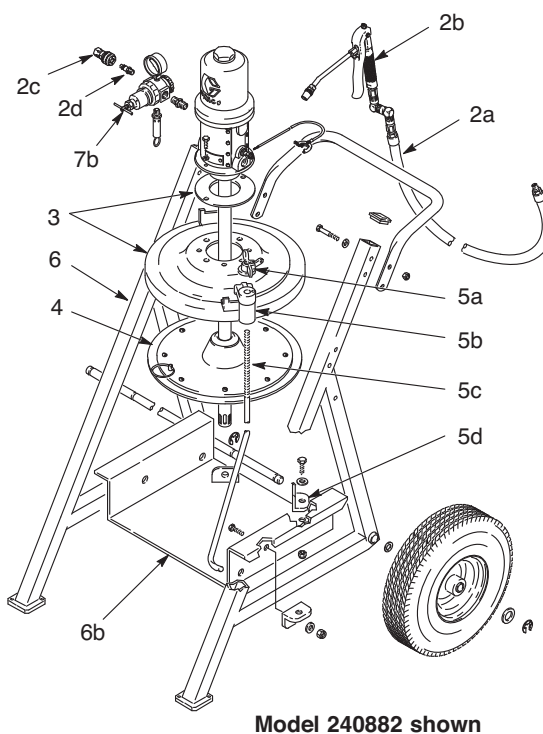

FIG. 5

Models 226012 and 240886

Refer to FIG. 7 for the following instructions unless otherwise indicated.

1. Assemble the truck as shown in the Parts Drawing on page 13 but do not assemble the handle.
2. Slide handle through elevator slide tube and secure handle to base.
3. Remove the fluid outlet adapter included with the pump, and screw the holster (6) into the pump outlet using thread sealant.
4. Secure pump to elevator mounting plate.
5. Remove inductor plate locking nut, locking ring, and o-ring. (FIG. 6)

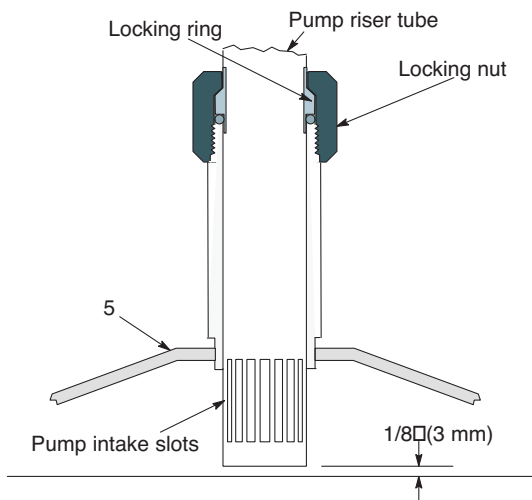

FIG. 6

6. In order, slide inductor plate locking nut, locking ring, and o-ring on pump riser tube.
7. Adjust the inductor plate (5) on the pump riser tube so the slots are showing just below the inside of the plate. Tighten the locking nut securely. (FIG. 6)
8. Open the inductor plate vent by turning the knob counter clockwise.
9. Place an open 50 lb (22.68 kg) pail of grease on the truck and secure it with the hold-down clamps.
10. Remove the cover from the pail and scoop the lubricant from the center to the sides of the pail to make its surface concave.

11. Center the inductor plate (5) in the pail opening. Press down on the pump and rock it back and forth to seat the inductor plate to eliminate air pockets. Continue action until material appears at the vent opening.
12. Close the inductor plate vent by turning the knob clockwise.
13. Assemble the gun (2b), Z-swivel, and hose (2a).
14. Connect hose (2a) to holster (6) or to pump fluid outlet adapter if you chose not to use the holster. Connect the nipple (2d) to the pump air inlet or air regulator inlet (7b), whichever is applicable.
15. Connect the quick-disconnect coupler (2c) to the air supply hose.

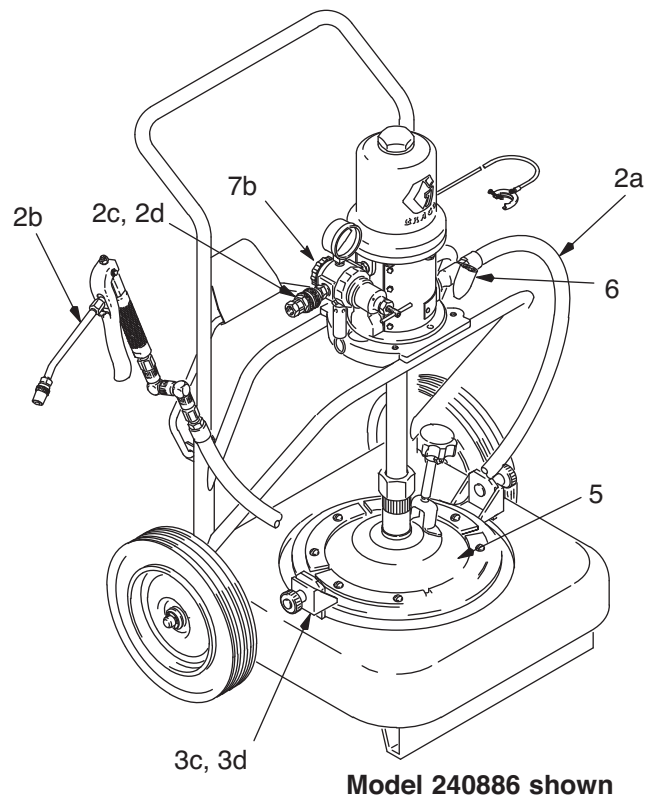

FIG. 7

Typical Installation

The installation shown below is only a guide for selecting and installing system components and accessories. Contact your Graco distributor for assistance in designing a system to suit your particular needs.

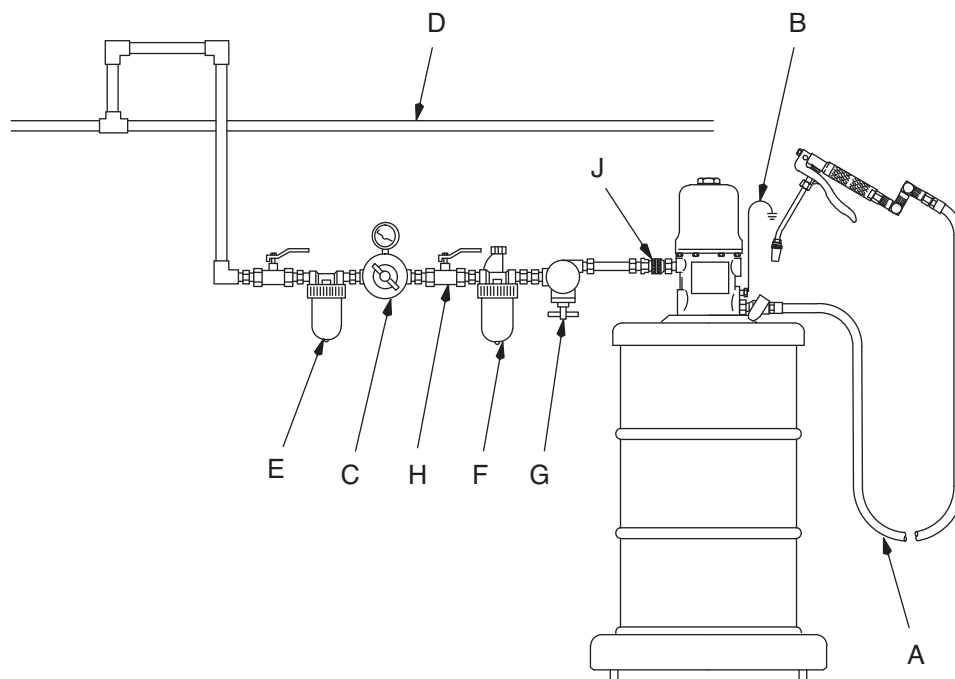

FIG. 8

Key:

- A Fluid dispense line
- B Pump ground wire (required)
- C Air regulator
- D Main air supply line
- E Air filter
- F Pump lubricator
- G Pump runaway valve
- H Bleed-type master air valve (required)
- J Quick-disconnect couple and nipple
- K Air regulator (7b) with safety valve (7c) and gauge (not shown) *Included with Models 240880 to 240886*

Air Line and Accessories

NOTE: Install air line accessories in the order shown in the Typical Installation.

- Install a pump runaway valve (G) to shut off the air to the pump if the pump accelerates beyond the pre-adjusted setting. A pump that runs too fast can be seriously damaged.
- Install an air line lubricator (F) for automatic air motor lubrication.
- Install a bleed-type master air valve (H) to relieve air trapped between the valve and the motor when the valve is closed.

						
<p>Trapped air can cause the air motor to cycle unexpectedly, causing serious injury if you are adjusting or repairing the pump. Follow the Pressure Relief Procedure on page 10.</p>						

- Install the air regulator (C) to control pump speed and pressure.
- On the main air supply line from the compressor, install an air line filter (E) to remove harmful dirt and contaminants from the compressed air supply.
- ***For Models 240880 through 240886***, install the provided air regulator/safety valve (K) at the pump air inlet with the nipple (7a, also included).

NOTICE

Avoid hanging air accessories directly on the pump air inlet. The fittings are not strong enough to support the accessories and may cause one or more to break. If accessories must be installed directly on the pump, provide a bracket on which to mount them.

Operation

Pressure Relief Procedure



1. Shut off the air to the pump.
2. Bleed off the air pressure by closing the air regulator (self-relieving type), or closing the bleed-type master air valve installed upstream of the air regulator, or disconnecting the air supply hose at the quick-disconnect.
3. Hold a metal part of the gun or valve firmly to the side of a grounded metal waste container and trigger to relieve fluid pressure.

Start-up: Single or Multiple Pump Systems

1. Close the air regulator and bleed-type master air valves to all but one pump.
2. Open the master air valve from the compressor.
3. For the pump which is connected, trigger the dispensing valve into a grounded metal waste container, making firm metal-to-metal contact between the container and valve.
4. Open the bleed-type master air valve, and open the pump air regulator slowly until the pump is running. When the pump is primed and all air has been pushed out of the lines, release the trigger.
5. If you have more than one pump, repeat this procedure for each pump.

NOTE: When the pump is primed, and with sufficient air supplied, the pump starts when the dispensing valve is opened and shuts off when it is closed.

6. Set the air pressure to each pump at the lowest pressure needed to get the desired results.

NOTE: A pump runaway valve can be installed not he air line to automatically shut off the pump if it starts to run too slow.

Never allow the pump to run dry of the fluid being pumped. A dry pump will quickly accelerate to a high speed, possibly damaging itself. If the pump accelerates quickly or is running too fast, stop it immediately and check the fluid supply. If the supply container is empty and air has been pumped into the lines, prime the pump and lines with fluid, or flush it and leave it filled with a compatible solvent. Be sure to eliminate all air from the fluid system.

						
---	--	--	--	--	--	--

The maximum working pressure of each pump in your system may not be the same. To reduce the risk of over-pressurizing any part of your system, be sure you know the maximum working pressure rating of each pump and its connected components. Never exceed the maximum working pressure of the lowest rated components connected to a particular pump.

To determine the fluid output pressure using the air regulator reading, multiply the ratio of the pump by the air pressure down on the regulator gauge. For example:

50:(1) ratio x 100 psi air = 5000 psi fluid output

50:(1) ratio x 0.7 MPa air = 35 MPa fluid output

50:(1) ratio x 7 bar air = 350 bar fluid output

Limit the air to the pump so that no air line or fluid line component or accessory is over pressurized.

7. Read and follow the instructions supplied with each component in the system.
8. When shutting off the system, always follow the **Pressure Relief Procedure** on page 10.

Parts

Ref No 2, Dispense Kit 222070

Ref.	Part No.	Description	Qty
2a	109151	HOSE, 1/4 NPT (mbe), 12 ft (3.7 m)	1
2b	242056	VALVE	1
2c	114558	COUPLER, quick-disconnect	1
2d	169971	NIPPLE, quick-disconnect	1
2e	202577	Z-SWIVEL	1

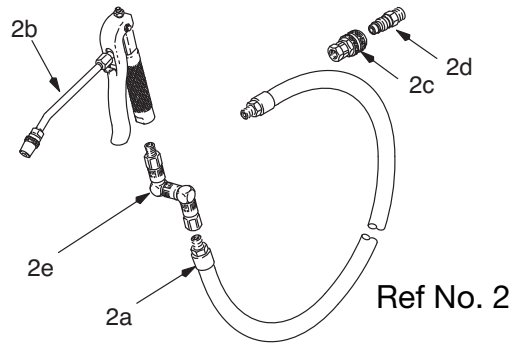

Model 225827, 240884: 35 lb to 50 lb pail size

Ref.	Part No.	Description	Qty
1	239877	PUMP, 50:1 Fire-Ball, See manual 308883 for parts	1
2	222070	DISPENSE KIT, See parts list above	1
3	204134	PAIL	1
4	24R350	COVER, See manual 306345 for parts, model 225827	1
	204574	COVER, See manual 306345 for parts, model 240884	1
6	203976	HOLSTER	1
7	240831	CE INSTALLATION KIT, See parts list on page 16, model 240884	1

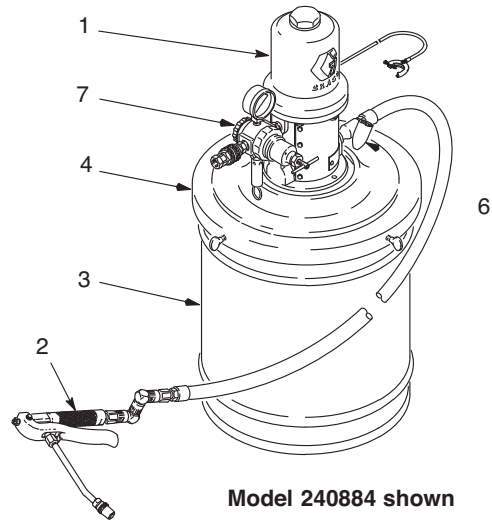

Model 222069, 245694, 240885: 25 lb to 50 lb pail size

Ref.	Part No.	Description	Qty
1	239877	PUMP, 50:1 Fire-Ball, See manual 308883 for parts	1
2	222070	DISPENSE KIT, see parts above	1
	245697	DISPENSE KIT, Model 245694 only, See parts list on page 14	1
3	222059	COVER, includes items 3a- 3h	1
3a	207617	COVER, pail	1
3b	168102	PLATE, stop, pump	1
3c	158048	BUMPER, button, rubber	1
3d	159608	RIVET	1
3e	150868	HOLDER, gun	1
3f	100200	SCREW, thumb	3
3g	100025	NUT, 1/4 npsm thd	1
3h	100579	PIN, cotter, 1/8 in. x 1 in.	1
5	220653	FOLLOW PLATE, See manual 306345 for parts, model 240885	1
	24R350	FOLLOW PLATE, see manual 306345, models 222069, 245694	1
7	240831	CE INSTALLATION KIT, See parts list on page 16, model 240885	1

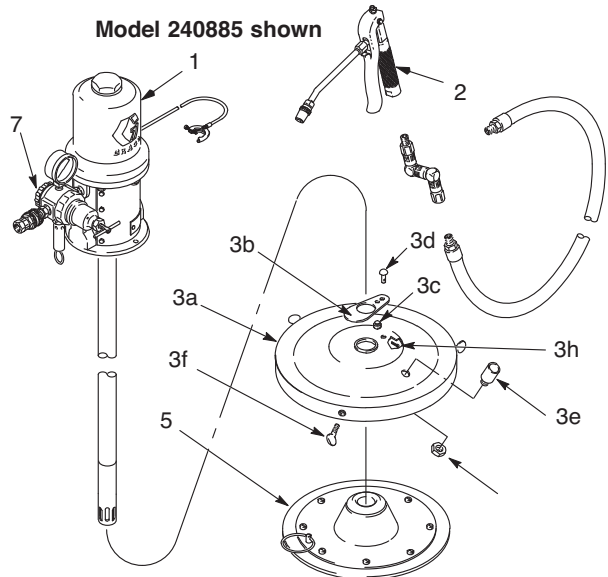

Model 225026, 245696, 240881: 120 lb drum size

Ref. Part No.	Description	Qty
1	239887 PUMP, 50:1 Fire-Ball, See manual 308883 for parts	1
2	222070 DISPENSE KIT, See parts, page 12	1
	245697 DISPENSE KIT, Model 245696 only, See parts, page 14	1
3	203650 TRUCK, 2 wheel, See parts below	1
4	204574 COVER, See manual 306345 for parts, models 245696, 240881	1
	24R350 COVER, See manual 306345 for parts, model 225026	1
5	220654 FOLLOW PLATE, See manual 306345 for parts, model 245696, 240881	1
	24F902 FOLLOW PLATE, See manual 306345 for parts, model 225026	1
6	203976 HOLSTER	1
7	240831 CE INSTALLATION KIT, See parts on page 16, model 240881	1

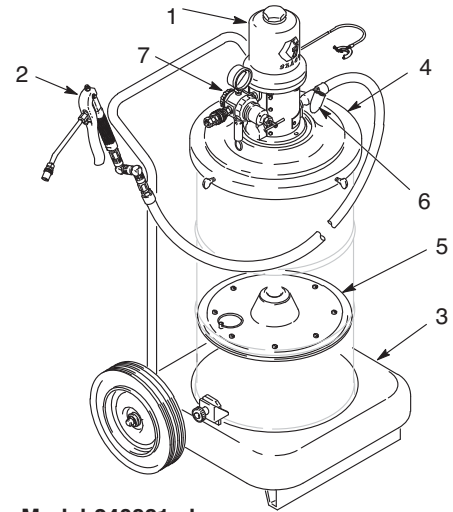

Model 240881 shown

Model 225773, 245695, 240883: 35 lb to 50 lb pail size

Ref. Part No.	Description	Qty
1	239877 PUMP, 50:1 Fire-Ball, See manual 308883 for parts	1
2	222070 DISPENSE KIT, See parts, page 12	1
	245697 DISPENSE KIT, Model 245696 only, See parts, page 14	1
3	203650 TRUCK, 2 wheel, See parts below	1
4	204574 COVER, See manual 306345 for parts, models 245695, 240883	1
	24R350 COVER, See manual 306345 for parts, model 225773	1
5	204134 PAIL	1
6	203976 HOLSTER	1
7	240831 CE INSTALLATION KIT, See part list on page 16, models 240883	1

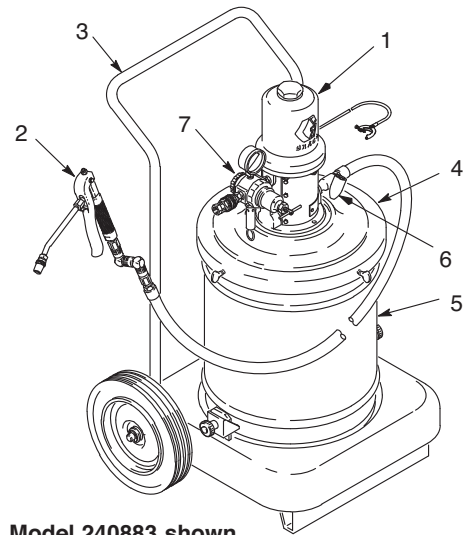

Model 240883 shown

Ref No. 3, Truck 203650

Ref. Part No.	Description	Qty
3a	203651 BASE, truck, bare	1
3b	101251 WHEEL	2
3c	159912 NUT, thumb, 5/16-18	2
3d	159913 CLAMP, hold down, steel drums only	2
	159952* CLAMP, hold down, 5 gallon pail	2
3e	154636 WASHER, 5/8 in., 16 GA	4
3f	100609 SCREW, rd nd mach, 1/4-20 x 3/8 in.	2
3g	101242 RING, retaining	2
3h	159924 HANDLE, truck	1

*Must be ordered separately.

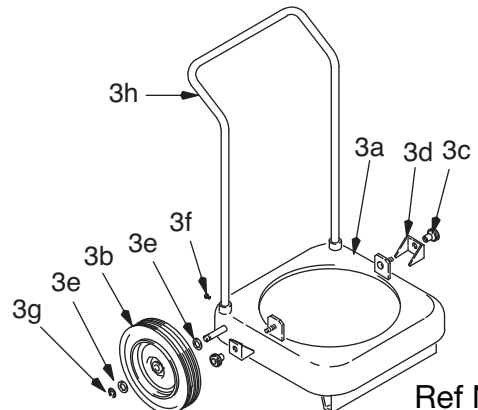

Ref No. 3

Model 225006, 240880, 25C688: 120 lb drum size

Ref.	Part No.	Description	Qty.
1	239887	PUMP, 50:1 Fire-Ball, See manual 308883 for parts	1
2	222070	DISPENSE KIT, See parts, page 12	1
3	203622	PORTABLE BASE, See parts list below, models 225006, 240880	1
4	204574	COVER, See manual 306345 for parts, model 240880	1
	24R350	COVER, See manual 306345 for parts, models 225006, 25C688	1
5	220654	FOLLOW PLATE, See manual 306345 for parts, model 240880	1
5	24F902	FOLLOW PLATE, See manual 306345 for parts, models 225006, 25C688	1
6	203976	HOLSTER, models 225006, 240880	1
7	240831	CE INSTALLATION KIT, See parts on page 16, model 240880	1

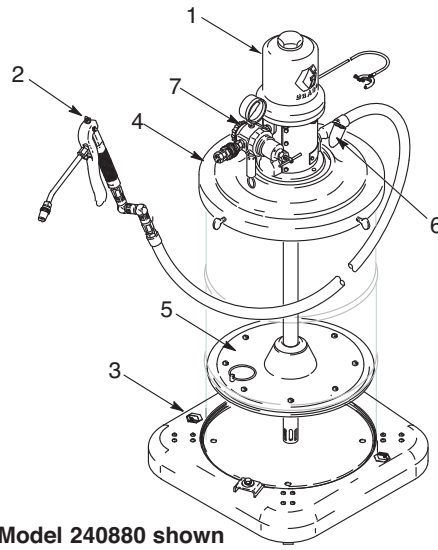

Ref No. 3, Portable Base 203622, Series B

Ref.	Part No.	Description	Qty.
			.
3a	191750	BASE, drum	1
3b	102547	BOLT, hex hd, 5/16 in. -18 x 1.5 in.	2
3c	191747	BRACKET	2
3d	100214	WASHER, lock	2
3e	100132	WASHER, flat	2
3f	113660	RIVET	16
3g	113646	CASTER, polyurethane	4

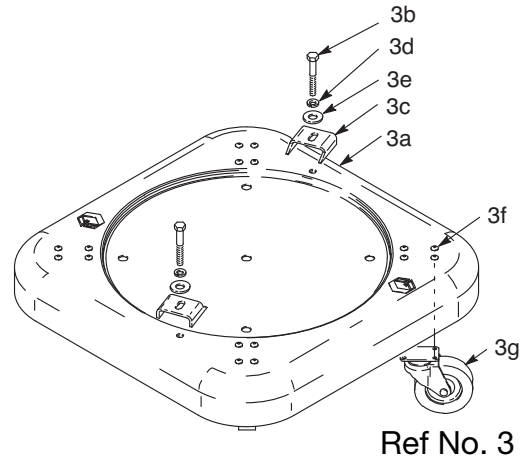

Ref No. 2, Dispense Kit 245697

Ref	Part No.	Description	Qty.
			.
2a	109151	HOSE, 1/4 NPT(mbe), 12 ft (3.7 m)	1
2b	233807	VALVE	1
2c	114558	COUPLER, quick-disconnect	1
2d	169971	NIPPLE, quick-disconnect	1
2e	202577	Z-SWIVEL	1

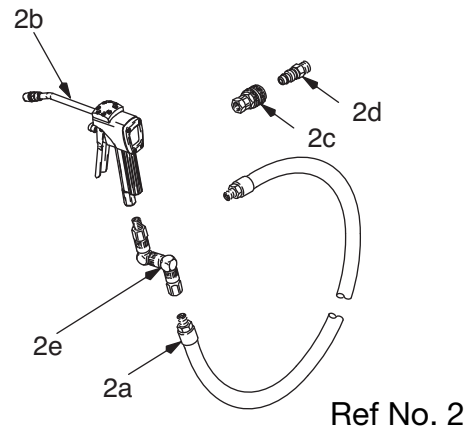

Ref No. 2, Dispense Kit 222838

Ref	Part No.	Description	Qty
2a	109154	HOSE	1
2b	242056	VALVE	1
2c	114558	COUPLER, quick-disconnect	1
2d	169971	NIPPLE, quick-disconnect	1
2e	202577	Z-SWIVEL	1

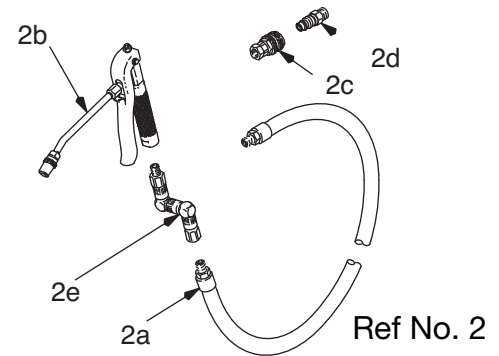

Model 222245, 240882: 120 lb drum size

Ref	Part No.	Description	Qty
1	239887	PUMP, 50:1 Fire-Ball, See manual 308883 for parts	1
2	222383	DISPENSE KIT, See parts list above	1
3	222060	COVER, See manual 306345 for parts	1
4	220654	FOLLOW PLATE, See manual 306345 for parts, model 240882	1
	24F902	FOLLOW PLATE, See manual 306345 for parts, model 222245	1
5	222061	HOLD DOWN KIT, Includes items 5a to 5d	1
5a	200889	NUT, wing	2
5b	153166	HOOK, drum mounting	2
5c	153102	ROD, drum	2
5d	159016	BRACKET, retaining (2 used)	4
6	222243	CART KIT, includes items 6a to 6p	1
6a	218027	FRAME, cart	2
6b	183987	SHELF, drum	1
6c	107144	SCREW, cap, 3/8-16 x2-1/4	4
6d	179766	HANDLE, cart	1
6e	100731	WASHER, flat, 3/8	6
6f	101566	LOCKNUT, hex, 3/8-16	6
6g	179770	AXLE	1
6h	154628	WASHER, flat, 3/4	4
6j	107146	RING, retaining, ext, 3/4	4
6k	106039	WHEEL, tire, pneumatic	2
6m	107145	CAP, tube	2
6n	100680	CAPSCREW, 3/8-16 x 7/8	2
6p	159016	BRACKET, retaining	2
7	240831	CE INSTALLATION KIT, See part list on page 16, model 240882	1

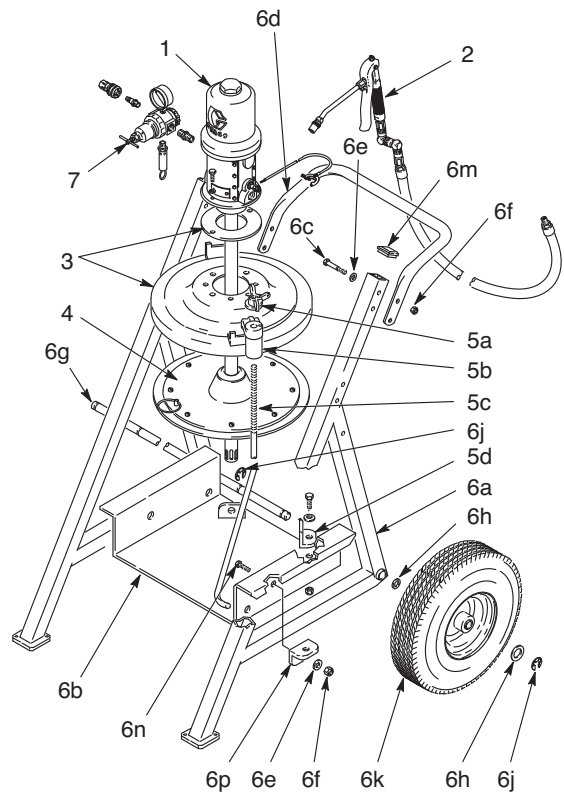

Model 226012, 240886: 50 lb pail size

Ref.	Part No.	Description	Qty.
1	239877	PUMP, 50:1 Fire-Ball, See manual 308883 for parts	1
2	222070	DISPENSE KIT, See parts, page 12	1
3	203650	TRUCK, portable, See parts list on page 13	1
4	203664	ELEVATOR	1
5	204351	FOLLOW PLATE	1
6	203976	HOLSTER	1
7	240831	CE INSTALLATION KIT, See parts list below, model 240886	1

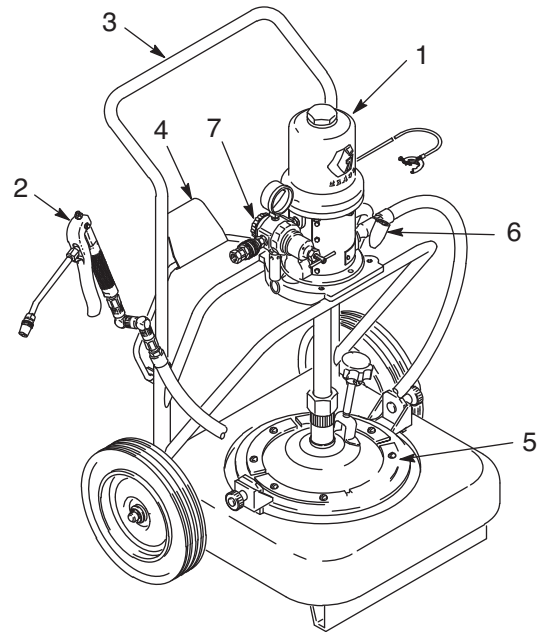

Model 240886 shown

Ref No. 7, CE Installation Kit 240831

Ref.	Part No.	Description	Qty.
7a	156849	NIPPLE	1
7b	109075	REGULATOR, air, with gauge	1
7c	103347	VALVE, safety	1
7d	222011	CLAMPING, grounding	1
7e	†	CE Label	1

† **ATTENTION:** To comply with CE directives, the CE identification label must be affixed to the back of the cart or to the top of the drum cover. Permanently mark the date of the assembly on the label.

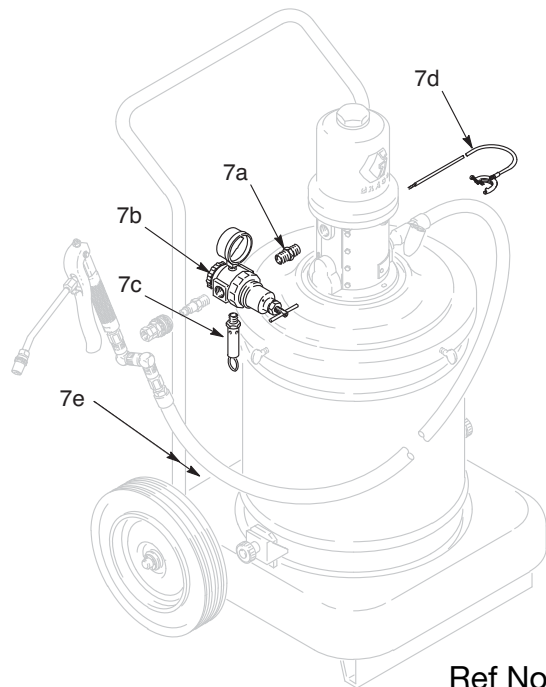

Ref No. 7

Technical Data

50:1 Ratio Fire-Ball Lubrication Pumps		
	US	Metric
Maximum fluid working pressure	5000 psi	35 MPa, 350 bar
Maximum Air Inlet Pressure	100 psi	0.7 MPa, 7 bar
Sound (dBa)		
Tested at 100 psi (0.7 MPa, 7 bar) at 40 cycles per minute		
Sound Pressure Level, measured at 1 meter from unit	77.9 dB(A)	
Sound Power Level, tested in accordance with ISO 9614-2	85.6 dB(A)	

California Proposition 65

 **WARNING:** This product can expose you to chemicals known to the State of California to cause cancer and birth defects or other reproductive harm. For more information, go to www.P65warnings.ca.gov.

Graco Standard Warranty

Graco warrants all equipment referenced in this document which is manufactured by Graco and bearing its name to be free from defects in material and workmanship on the date of sale to the original purchaser for use. With the exception of any special, extended, or limited warranty published by Graco, Graco will, for a period of twelve months from the date of sale, repair or replace any part of the equipment determined by Graco to be defective. This warranty applies only when the equipment is installed, operated and maintained in accordance with Graco's written recommendations.

This warranty does not cover, and Graco shall not be liable for general wear and tear, or any malfunction, damage or wear caused by faulty installation, misapplication, abrasion, corrosion, inadequate or improper maintenance, negligence, accident, tampering, or substitution of non-Graco component parts. Nor shall Graco be liable for malfunction, damage or wear caused by the incompatibility of Graco equipment with structures, accessories, equipment or materials not supplied by Graco, or the improper design, manufacture, installation, operation or maintenance of structures, accessories, equipment or materials not supplied by Graco.

This warranty is conditioned upon the prepaid return of the equipment claimed to be defective to an authorized Graco distributor for verification of the claimed defect. If the claimed defect is verified, Graco will repair or replace free of charge any defective parts. The equipment will be returned to the original purchaser transportation prepaid. If inspection of the equipment does not disclose any defect in material or workmanship, repairs will be made at a reasonable charge, which charges may include the costs of parts, labor, and transportation.

THIS WARRANTY IS EXCLUSIVE, AND IS IN LIEU OF ANY OTHER WARRANTIES, EXPRESS OR IMPLIED, INCLUDING BUT NOT LIMITED TO WARRANTY OF MERCHANTABILITY OR WARRANTY OF FITNESS FOR A PARTICULAR PURPOSE.

Graco's sole obligation and buyer's sole remedy for any breach of warranty shall be as set forth above. The buyer agrees that no other remedy (including, but not limited to, incidental or consequential damages for lost profits, lost sales, injury to person or property, or any other incidental or consequential loss) shall be available. Any action for breach of warranty must be brought within two (2) years of the date of sale.

GRACO MAKES NO WARRANTY, AND DISCLAIMS ALL IMPLIED WARRANTIES OF MERCHANTABILITY AND FITNESS FOR A PARTICULAR PURPOSE, IN CONNECTION WITH ACCESSORIES, EQUIPMENT, MATERIALS OR COMPONENTS SOLD BUT NOT MANUFACTURED BY GRACO. These items sold, but not manufactured by Graco (such as electric motors, switches, hose, etc.), are subject to the warranty, if any, of their manufacturer. Graco will provide purchaser with reasonable assistance in making any claim for breach of these warranties.

In no event will Graco be liable for indirect, incidental, special or consequential damages resulting from Graco supplying equipment hereunder, or the furnishing, performance, or use of any products or other goods sold hereto, whether due to a breach of contract, breach of warranty, the negligence of Graco, or otherwise.

FOR GRACO CANADA CUSTOMERS

The Parties acknowledge that they have required that the present document, as well as all documents, notices and legal proceedings entered into, given or instituted pursuant hereto or relating directly or indirectly hereto, be drawn up in English. Les parties reconnaissent avoir convenu que la rédaction du présente document sera en Anglais, ainsi que tous documents, avis et procédures judiciaires exécutés, donnés ou intentés, à la suite de ou en rapport, directement ou indirectement, avec les procédures concernées.

Graco Information

For the latest information about Graco products, visit www.graco.com.

TO PLACE AN ORDER, contact your Graco distributor or call to identify the nearest distributor.

Phone: 612-623-6928 or **Toll Free:** 1-800-533-9655, **Fax:** 612-378-3590

*All written and visual data contained in this document reflects the latest product information available at the time of publication.
Graco reserves the right to make changes at any time without notice.*

For patent information, see www.graco.com/patents.

Original instructions. This manual contains English. MM 307878

Graco Headquarters: Minneapolis
International Offices: Belgium, China, Japan, Korea

GRACO INC. AND SUBSIDIARIES • P.O. BOX 1441 • MINNEAPOLIS MN 55440-1441 • USA

Copyright 1988, Graco Inc. All Graco manufacturing locations are registered to ISO 9001.

www.graco.com

Revision ZAD, November 2024