

Instructions – Parts List



1:1 RATIO, 210 LITER (55 GAL.) SIZE

Foam-Cat[®] Feed Pump

307552M
EN

For use in drums of polyurethane chemicals.

180 psi (1.2 MPa, 12.4 bar) Maximum Air Working Pressure

180 psi (1.2 MPa, 12.4 bar) Maximum Material Working Pressure

Model No. 226946, Series B

Includes airtight bung adapter

Feed Pump Kit 217381 (obsolete)

Includes two Model 226946 Feed Pumps, air dryer,
and air and fluid hoses.



Read warnings and instructions. See page 2
for Table of Contents.

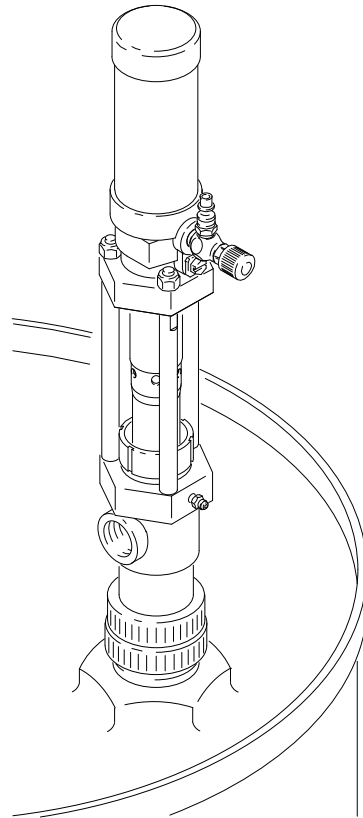

05217B



PROVEN QUALITY. LEADING TECHNOLOGY.

GRACO INC. P.O. BOX 1441 MINNEAPOLIS, MN 55440-1441

© Graco Inc., 1982. Graco Inc. is registered to I.S. EN ISO 9001



II 1/2 G Ex h IIB T6 Ga/Gb
CML 24ATEX6024

Table of Contents

Symbols	2
Installation	4
Operation	7
Maintenance	8
Troubleshooting	9
Service	10
Parts Drawing	12
Parts List	13
Technical Data	15
Graco Standard Warranty	16

Symbols

Warning Symbol



This symbol alerts you to the possibility of serious injury or death if you do not follow the instructions.

Caution Symbol



This symbol alerts you to the possibility of damage to or destruction of equipment if you do not follow the instructions.

WARNING



INSTRUCTIONS

Equipment misuse can cause the equipment to rupture or malfunction and result in serious injury.

- This equipment is for professional use only.
- Read all instruction manuals, tags, and labels before operating the equipment.
- Use the equipment only for its intended purpose. If you are not sure, call your Graco distributor.
- Do not alter or modify this equipment.
- Check equipment daily. Repair or replace worn or damaged parts immediately.
- Do not exceed the maximum working pressure of the lowest rated component in your system. This equipment has a **180 psi (1.2 MPa, 12.4 bar) maximum working pressure at 180 psi (1.2 MPa, 12.4 bar) maximum incoming air pressure.**
- Use fluids and solvents which are compatible with the equipment wetted parts. Refer to the **Technical Data** section of all equipment manuals. Read the fluid and solvent manufacturer's warnings.
- Do not use hoses to pull equipment.
- Route hoses away from traffic areas, sharp edges, moving parts, and hot surfaces. Do not expose Graco hoses to temperatures above 82°C (180°F) or below -40°C (-40°F).
- Securely mount the pump. Do not attempt to operate it while holding it.
- Do not lift pressurized equipment.
- Comply with all applicable local, state, and national fire, electrical, and safety regulations.
- Graco Inc. does not manufacture or supply any of the reactive chemical materials that may be used in this equipment and is not responsible for their effects. Because of the vast number of chemicals that could be used and their varying chemical reactions, before using this equipment, the buyer and the user should determine all facts relating to the materials used, including any of the potential hazards involved. Particular inquiry and investigation should be made into potential dangers relating to toxic fumes, fires, explosions, reaction times, and exposure of human beings to the individual components or their resultant mixtures. Graco assumes no responsibility for loss, damage, expense or claims for bodily injury or property damage, direct or consequential, arising from the use of such chemical components.

WARNING



TOXIC FLUID HAZARD

Hazardous fluid or toxic fumes can cause serious injury or death if splashed in the eyes or on the skin, inhaled, or swallowed.

- Know the specific hazards of the fluid you are using.
- Store hazardous fluid in an approved container. Dispose of hazardous fluid according to all local, state and national guidelines.
- Any additives to the air supply, such as oil or anti-freeze will be exhausted into the atmosphere.
- Always wear protective eyewear, gloves, clothing and respirator as recommended by the fluid and solvent manufacturer.



FIRE AND EXPLOSION HAZARD

Improper grounding, poor ventilation, open flames or sparks can cause a hazardous condition and result in a fire or explosion and serious injury.

- Ground the equipment. Refer to **Grounding** on page 5.
- If there is any static sparking or you feel an electric shock while using this equipment, **stop pumping immediately**. Do not use the equipment until you identify and correct the problem.
- Provide fresh air ventilation to avoid the buildup of flammable fumes from solvents or the fluid being sprayed.
- Keep the work area free of debris, including solvent, rags, and gasoline.
- Electrically disconnect all equipment in the work area.
- Extinguish all open flames or pilot lights in the work area.
- Do not smoke in the work area.
- Do not turn on or off any light switch in the work area while operating or if fumes are present.
- Do not operate a gasoline engine in the work area.



MOVING PARTS HAZARD

Moving parts can pinch or amputate your fingers.

- Keep clear of all moving parts when starting or operating the pump.
- Before servicing the equipment, follow the **Pressure Relief Procedure** on page 7 to prevent the equipment from starting accidentally.

Installation

NOTE: The terms ISO and RES used in the text refer to the polyurethane foam chemicals, Isocyanate and Resin.

NOTE: Reference numbers and letters in parentheses in the text refer to the figure illustrations and the Parts Drawing.

⚠ WARNING

A bleed-type master air valve (E) is required in your system, to help reduce the risk of serious injury, including splashing fluid in the eyes or on the skin, and injury from moving parts if you are adjusting or repairing the pump.

The *bleed-type master air valve* (E) relieves air trapped between this valve and the pump after the pump is shut off. Trapped air can cause the pump to cycle unexpectedly and result in serious injury, including amputation. Locate the valve close to the pump.

4. Install an air regulator in the feed pump air inlet to control pump speed. To install, remove the air valve (8) and use suitable adapters for the regulator and pin fitting. Use thread sealer on male threads.

Installing the Feed Pumps

1. Screw the bung adapter (40) and pump tightly into the drum cover. See Fig 1.
2. Tighten the retainer (38) firmly to complete the airtight seal.
3. Separate the two halves of the identification label (15) along the perforation. Clean the surface of the air motor with solvent and apply the appropriate label (RES or ISO) to identify the type of material being pumped.

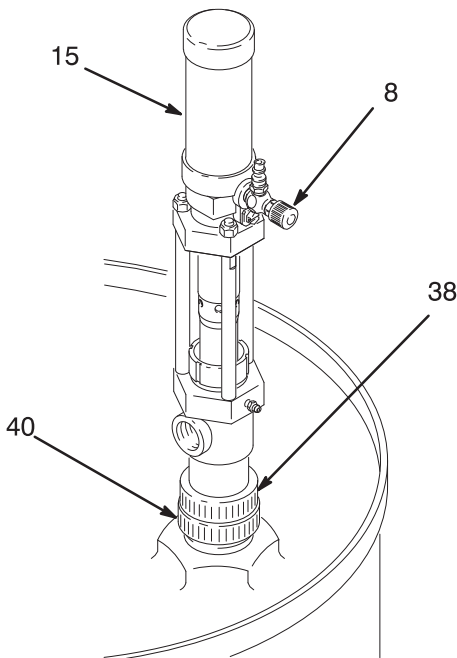

05217B

FIG. 1

Installation

5. Connect an air supply hose to the 1/4 npt air line coupler (13). Air supply hoses (103) are supplied in Kit 217381. See Fig 3, page 6.
6. Connect a fluid supply hose from the 3/4 npt(f) fluid outlet of the ISO feed pump to the inlet fitting of the ISO proportioning pump, using adapters as needed. Then connect a fluid supply hose between the RES feed pump and RES proportioning pump.

⚠ CAUTION

Be sure all hose connections in your polyurethane foam spray system are clearly labeled ISO or RES and make connections only with identically labeled components to avoid material crossing.

Crossing polyurethane materials will cause the material to harden in the equipment and may permanently damage it.

Grounding

⚠ WARNING

Static electricity is created by the high velocity flow of fluid through the pump and hoses. If every part of the spray system, and all objects in the spray area are not properly grounded, the static electricity may cause sparking. Sparks can ignite fumes from solvents and the fluid being sprayed, dust particles, and other flammable substances, causing a fire, explosion and serious bodily injury and property damage.

To reduce the risk of static sparking, use only conductive air and fluid hoses and be sure your entire system is properly grounded. Ground the feed pumps as explained below.

Remove the ground screw (Z) and insert through eye of ring terminal at the end of ground wire (Y). Fasten ground screw back onto pump and tighten securely. See Fig 2. Connect the other end of the wire to a true earth ground. Order Part No. 222011 Ground Wire and Clamp.

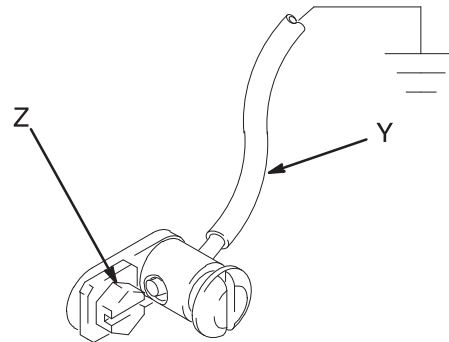

FIG. 2

T11052

Feed Pump Kit Installation

The following instructions assume you are using this kit with a Graco Foam-Cat Sprayer.

1. Install the feed pumps as described in Steps 1–4, on page 4.
2. Mount the Air Dryer (105) in any suitable location. Refer to manual 307548 for the mounting hole diagram. See Fig 3.
3. Unscrew the air dryer ring (F) to remove the bowl. See Fig 3. Remove the filter and fill the bowl with the desiccant, provided. Reassemble.

⚠ CAUTION

One end of each fluid hose and each drum nipple (G) of the drum fittings (H) is labeled ISO or RES. Make only ISO to ISO and RES to RES connections to avoid material crossing.

4. Install the drum fittings (H) in the 3/4 in. vent port of the proper drum.

Installation

KEY

- A Air Line
- B Air Line Filter
- E Bleed-type master valve
- F Air Dryer Ring
- G Nipple
- H Drum Air Fittings
- J Pin Fitting
- K Ball Valve
- L Bushing
- M Air Hose (Air Dryer)
- N Special Air Coupler
- 7 Pin Fitting
- 8 Air Control Valve
- 13 Air Line Coupler
- 103 Air Hoses (Pump)
- 104 Bushing
- 105 Air Dryer

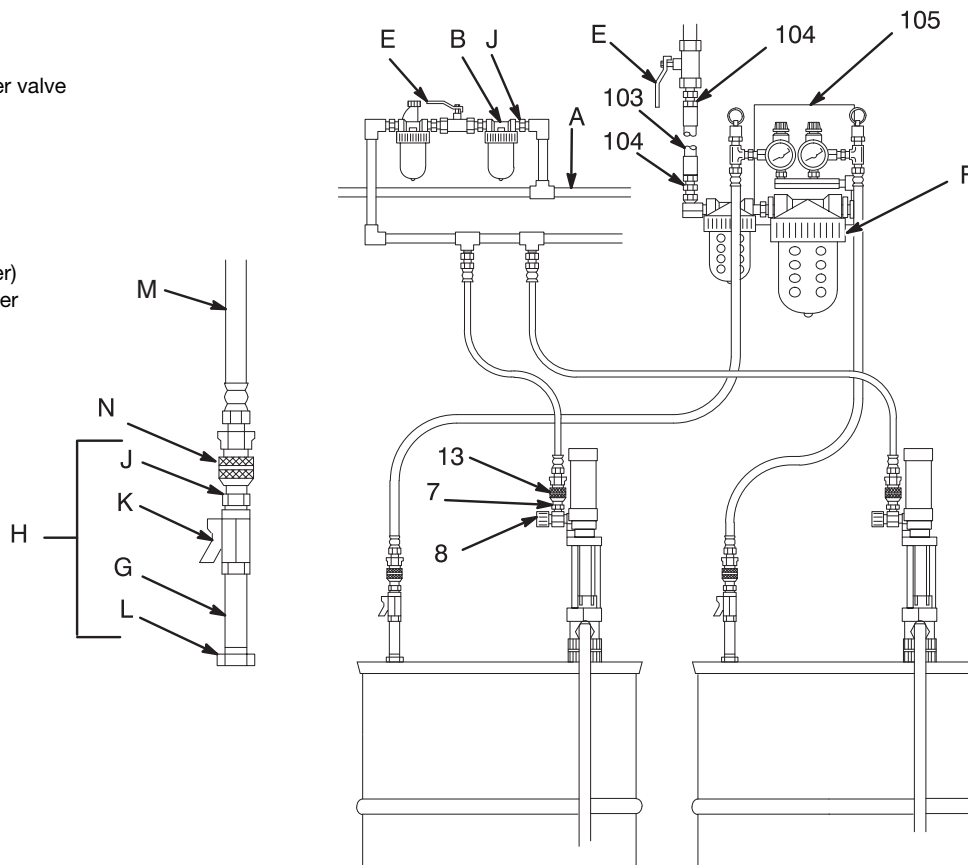

FIG. 3

05218

5. Connect the dry air hoses (M) to the identically labeled drum fittings using the special pin fitting (J) and coupler (N). See Fig 3.

⚠ WARNING

The special air line fitting (J) and coupler (N) are designed to prevent accidentally coupling an unregulated air supply hose to the container. Unregulated air can overpressurize the container and cause it to rupture, resulting in serious bodily injury and property damage. If the coupler and fitting ever needs to be replaced use only original Graco parts.

Never substitute a different type of coupler and fitting!

6. Attach a bushing (104) to one end of two of the air supply hoses (103) and attach a bushing to each end of the third air hose. See the Parts Drawing on page 13.
7. Connect one air hose between the feed pump and the 1/2 npt(f) air manifold on the side of the Foam-Cat sprayer pump stand. Repeat for the other feed pump.
8. Connect the hose with the two bushings between the 1/2 npt(f) air inlet of the Air Dryer and a bleed-type master air valve (E), required. Then connect the main air supply line to the air valve.
9. Connect the ISO fluid hose between the 3/4 npt(f) fluid outlet of the ISO feed pump and the 3/4 npt(f) inlet of the corresponding displacement pump. Repeat for the RES pumps.

Operation

Pressure Relief Procedure

WARNING

PRESSURIZED EQUIPMENT HAZARD

The system pressure must be manually relieved to prevent the system from starting or spraying accidentally. To reduce the risk of an injury from accidental spray from the gun, splashing fluid, or moving parts, follow the **Pressure Relief Procedure** whenever you:

- are instructed to relieve the pressure,
- have an air supply interruption,
- stop spraying,
- check or service any of the system equipment,
- or install or clean the spray nozzle.

Starting and Operating the Pump

This pump is designed to be used with a Graco Foam-Cat Sprayer. If you have purchased such a sprayer, complete warning and operating instructions are contained in the manual (307541 or 307542) which accompanied the sprayer. If you have misplaced these manuals, obtain additional copies by contacting your Graco distributor.

In general operation, when the pump is used for transfer and supply operations with no dispensing valve, the pump will run whenever air is supplied.

Normally, the Feed Pump air valve is opened before any other equipment in the spray system is turned on. This is so fluid can be supplied to the components immediately. For shutdown, disconnect the air line coupler (13). See Fig 4.

Never let the pump run when the drum is empty. A dry pump can quickly accelerate to a high speed and damage itself. If the pump is running too fast, stop it immediately and check and refill the material supply, or flush the pump with a compatible solvent if you stop spraying for the day. Always prime the entire system with fluid to remove any air pumped into the system. Refer to Manual 307541 or 307542. Don't let the material harden in the pump.

Feed Pump Kit

Refer to the operation instructions on page 2 of manual 307548, which was supplied with the Air Dryer, and the above instructions for operating the Feed Pumps.

Changing Drums

CAUTION

To avoid crossing material when changing drums, complete the changing of one type of material before starting the other.

1. Disconnect the hose coupler (N) from the Air Dryer drum fittings (H). See Fig 3.
2. Leave the ball valve (K) open for a few minutes to release the air pressure in the drum, then close the valves.
3. Remove the pump and the drum fittings from the drum cover and install them in the new drum of material.
4. Repeat this procedure for the other material.

Maintenance

Bung Adapter

If the ISO material shows signs of crystallization, and whenever the pump is removed from the drum, check the o-ring (39) and gasket (41) for wear or damage, replacing as needed. Refer to the Parts Drawing.

ISO Pump Packing Protection and Lubrication

⚠ CAUTION

Use only IPL (Isocyanate Pump Lube) to lubricate the packings of the feed pump. Other types of lubricant are not as effective in preventing packing damage.

1. Insert the 14.6 oz. cartridge (16) of IPL in a standard grease gun.
2. At shutdown each day, stop the pump with the rod (34) in the down position, then lubricate the packings liberally with IPL through the grease fitting (36). Proper lubrication prevents pump sticking. See Fig 4.
3. Wipe off the extra, contaminated IPL from around the top of the packing nut (28) and displacement rod (34).
4. Coat the displacement rod with fresh IPL.

Flushing

⚠ CAUTION

Be sure the solvent used is compatible with the material to be pumped to avoid material contamination.

1. Connect a short hose to the pump outlet.
2. Insert the pump intake into a pail of solvent.
3. Direct the fluid hose into the pail.

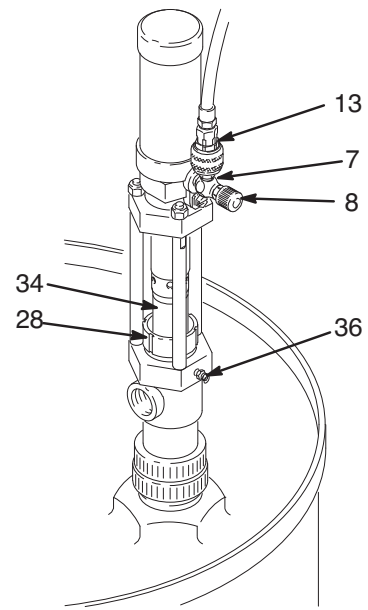

FIG. 4

Air Lubrication

If the air supply is dry, periodically oil the air motor. For manual lubrication, turn off the air, put about 15 drops of lightweight motor oil in the air inlet (7), reconnect the hose, and turn on the air. See Fig 4.

1. Open the air valve (8) or regulator to start the pump. Allow the pump to cycle slowly for at least 5 minutes.
2. Stop and disconnect the air hose.
3. Be sure to relieve the fluid pressure.
4. Push up on the intake valve (35) check plate to drain the lower part of the pump. See Fig 5.
5. Turn the pump over to drain the upper part of the pump.

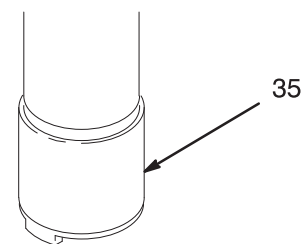

FIG. 5

Adjusting the Packing Nut

⚠ WARNING

Follow the **Pressure Relief Procedure** on page 7 before adjusting the packing nut.

Periodically, check the tightness of the packing nut (28). It should be tight enough to prevent leakage; no tighter. See Fig. 4. If the leakage cannot be stopped, change the packings to prevent exposure to the fluid being pumped.

Troubleshooting

WARNING

Follow the **Pressure Relief Procedure** on page 7 before servicing the pump.

Check all possible remedies before disassembling the pump.

PROBLEM	CAUSE	SOLUTION
Pump fails to operate	Material crystallized Dirty or worn air motor parts Inadequate air supply or restricted line Insufficient air pressure, closed or clogged air valves Clogged material hose or valve Worn or damaged valves or seals	Clean pump, use IPL more liberally Clean air motor, repair Clear line; see TECHNICAL DATA Check valves; increase pressure Clear obstruction Service pump
Pump operates, but output is low on both strokes	Clogged material hose or valve Exhausted material supply Worn or damaged valves or seals	Clear obstruction Refill Service pump
Pump operates, but output is low on down stroke	Worn or damaged valves or seals Intake valve held open	Service pump Clear valve, service pump
Pump operates, but output is low on up stroke	Worn or damaged valves or seals Piston valve held open	Service pump Clear valve, service pump
Erratic or accelerated operation	Exhausted material supply Broken air motor compression spring	Refill Replace spring

NOTE: Removing the muffler (P, Fig 6) will increase both the pump flow rate and the exhaust noise and will reduce icing.

Service

Disconnecting the Air Motor

Flush the pump, disconnect the air supply and relieve all pressures in the system. Remove the pump from its mounting. Unscrew the tie rod locknuts (3), remove the screw (5) and barrel (4) set and lift the air motor. Unscrew the rod (34). See Fig 6.

Reconnecting the Air Motor

Use lithium base grease on the threads of the rod (34). Insert the muffler (P) as shown. Hand tighten the rod (34) into the air motor connecting rod. Install the screw and barrel set (4 and 5). Lubricate the tie rod threads. To ensure alignment, thread the tie rod locknuts (3) loosely onto the tie rods, then torque evenly to 11 N•m (8 ft-lb). See Fig 6.

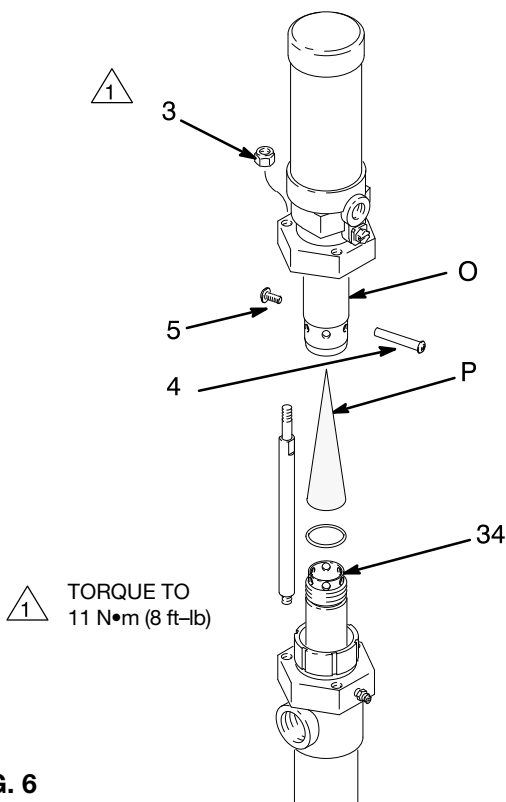

FIG. 6

03766B

Intake Valve

Unscrew the intake valve housing (35). Disassemble, clean and inspect all parts. Replace worn or damaged parts. See Fig 7.

Piston Valve

Use a strap wrench to grip the cylinder (25) near the housing (24) and unscrew it from the outlet housing. Pull the cylinder down, then loosen the lower nut (19). Unscrew the piston housing (33). Clean and inspect all parts. Replace worn or damaged parts. Screw the connecting rod all the way into the piston housing (33). Tighten the upper nut (19) against the piston housing and adjust the lower nut (19) to allow the piston disk (29) free travel of 3.1 mm (0.1235 in.). See Fig 7.

Throat Packings

Remove the cylinder (25). Loosen the packing nut (28). Pull the displacement rod (34) down and out. Remove the glands (21,22) and packings (32). Clean and inspect all parts. Replace worn or damaged parts.

Reassemble the pump. Install packings one at a time to be sure they nest properly. Leave the packing nut (28) loosen until the displacement rod (34) has been installed. Then tighten the packing nut firmly to seat the packings.

NOTE: Insert the displacement rod from the top of the outlet housing (24) to prevent packing damage.

Back the packing nut off until it no longer contacts the packings, then turn it in just until contact is made.

Service

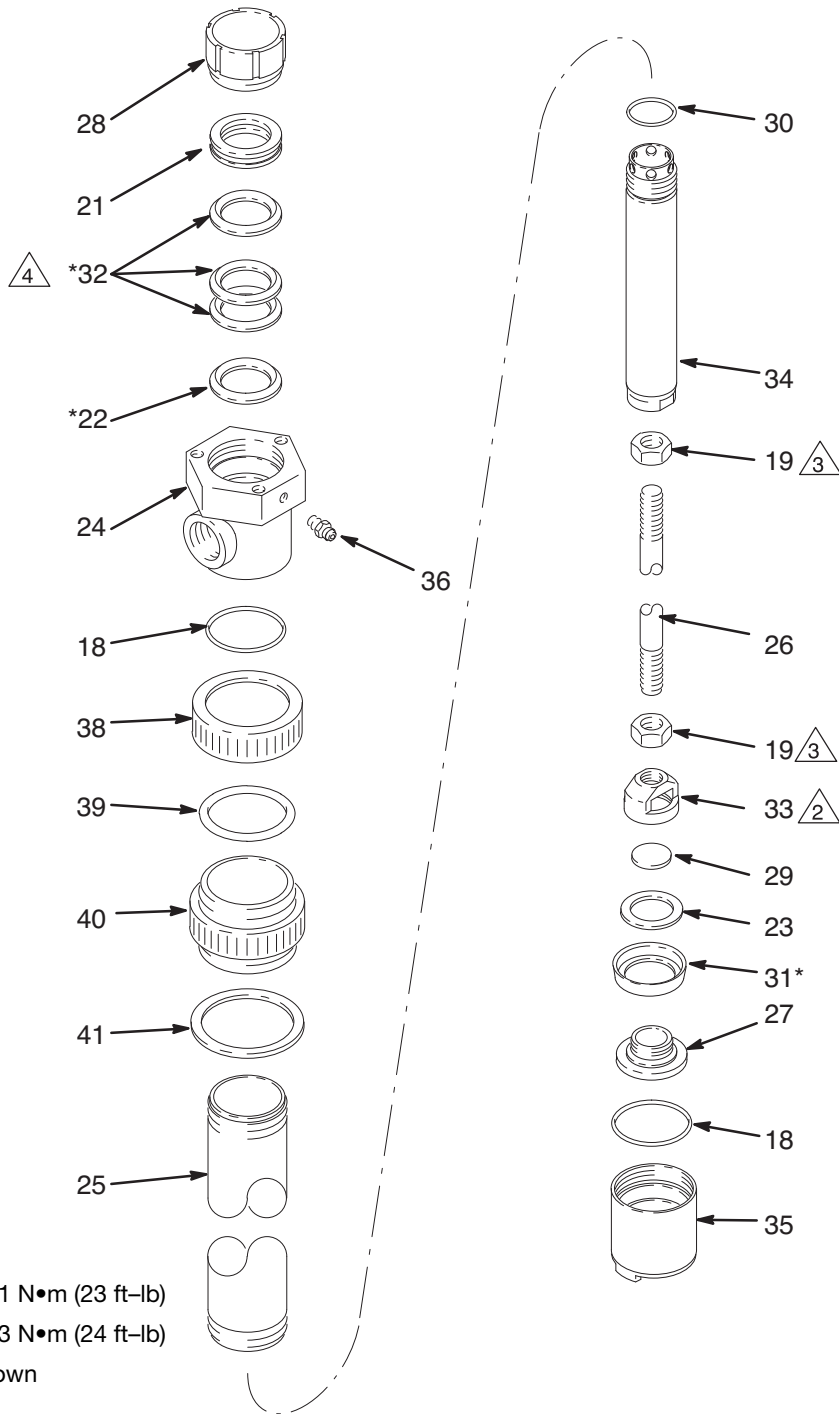

05221

FIG. 7

Parts Drawing

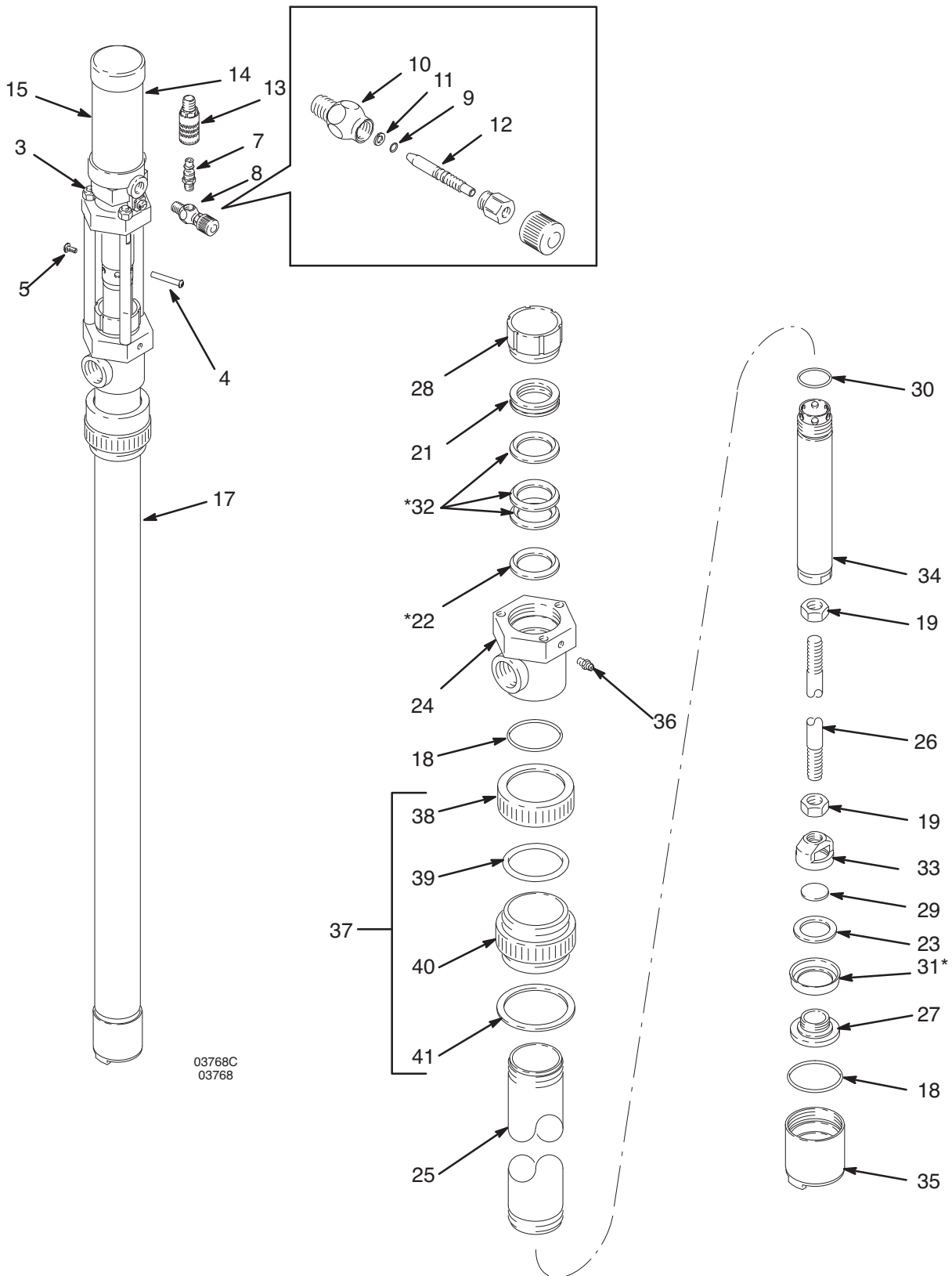

05221

Parts List

Model 226946, Series B Includes Items 1–42

Ref. No.	Part No.	Description	Qty.
1	100508	DRIVESCREW, #4 x 3/16", type U	2
3	104541	LOCKNUT, M8 w/nylon insert	3
4	15B249	PIN, barrel	1
5	15B250	SCREW	1
6	177171	TIE ROD	3
7	169969	FITTING, air line	1
8	206264	NEEDLE VALVE ASSEMBLY	
9**	157628	Includes items 9–12 PACKING, o-ring, nitrile rubber	1 1
10	165722	BODY	1
11	166531	RING, friction washer	1
12	206263	NEEDLE	1
13	114558	COUPLER, air line	1
14	215963	AIR MOTOR see manual 307456	1
15	178600	LABEL, ISO/RES	3
16	106565	ISO PUMP LIQUID, 14.6 oz	1
17	217383	DISPLACEMENT PUMP	
18	104537	Includes Items 18–36 O-RING, PTFE	1 2
19	105775	NUT, hex, M14 x 1.5	
21*	178543	GLAND, female packing, PTFE	1
22*	172385	GLAND, male packing, sst	1
23	172393	WASHER, SST	1
24	178542	HOUSING, outlet	1
25	172416	CYLINDER	1
26	177150	ROD, connecting	1
27	177151	PISTON, pump	1
28	177152	NUT, packing	1
29	177155	DISK, piston	1
30	177156	O-RING, Viton®	1
31*	172489	CUP, piston	1
32*	172487	V-PACKING	3
33	177168	HOUSING, valve piston	1
34	217189	ROD, displacement	1
35	217102	VALVE, intake	1
36	101281	FITTING, grease	1
37	217359	BUNG ADAPTER	
38	178576	Includes Items 38–41 RETAINER, O-RING	1 1

39	106536	PACKING, o-ring, ethylene propylene	1
40	178575	ADAPTER, bung, 2" npsm(m)	1
41	106537	GASKET, polyethylene	1
42▲	172479	TAG, warning (not shown)	1

▲ Replacement safety labels, tags, and cards are available at no cost.

* These parts are included in Repair Kit 213013, which may be purchased separately.

**Keep these spare parts on hand to reduce down time.

Feed Pump Kit 217381 Includes Items 101–105

Ref. No.	Part No.	Description	Qty.
101	226946	1:1 RATIO FAST-FLO FEED PUMP See parts at left.	2
102	217382	HOSE, fluid, cpld 3/4 npt(f), 10ft (3m)	2
103	200991	HOSE, fluid, cpld 1/4 npt(fbe), 10ft (3m)	3
104	100206	BUSHING, 1/2 x 1/4 npt	4
105	217341	AIR DRYER; see 307548 for parts	1

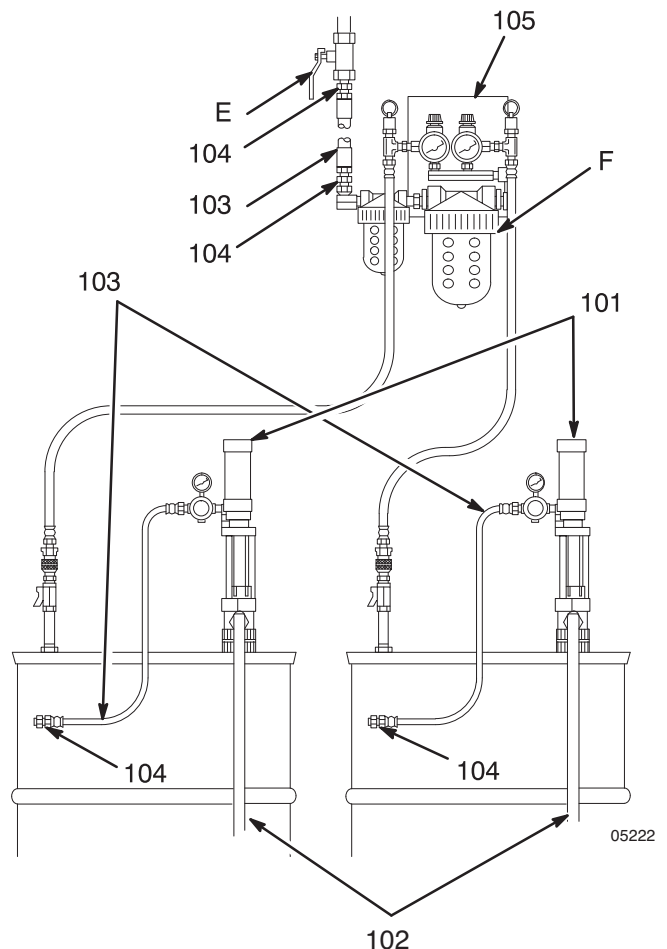

Technical Data

Recommended Air Operating Range	40–180 psi (0.3–1.2 MPa, 3–12 bar)
Air Consumption	Approx. 0.05 m ³ /min at 4 liters/min and 5.5 bar input (1.8 cfm at 1 gpm and 80 psi)
.	Up to 0.2 m ³ /min at 20 liters/min and 6.9 bar (6.8 cfm at 5 gpm and 100 psi)
Max. Recommended Pump Speed (Continuous Duty)	100 cycles/min 20 liters/min (5 gpm)
Fluid Outlet	3/4 npt(f)
Air Inlet	1/4 npt(f)
Fluid Inlet	1–1/2 npt(f)
Wetted Parts	Carbon steel, 300 series stainless steel, Leather, Cadmium plated ductile iron, Chrome and zinc plated steel, PTFE Polyethylene, Tefzel
Weight	6.5 kg (14.25 lb)
Max. Operating Temperature	49°C (120°F)
Sound Data	
Sound Pressure Level at 100 psi (0.7 MPa, 7 bar)	72 dB(A)
Sound Power Level at 100 psi (0.7 MPa, 7 bar)	82 dB(A)
Sound Pressure Level at 65 psi (0.4 MPa, 4.5 bar)	70 dB(A)
Sound Power Level at 65 psi (0.4 MPa, 4.5 bar)	70 dB(A)

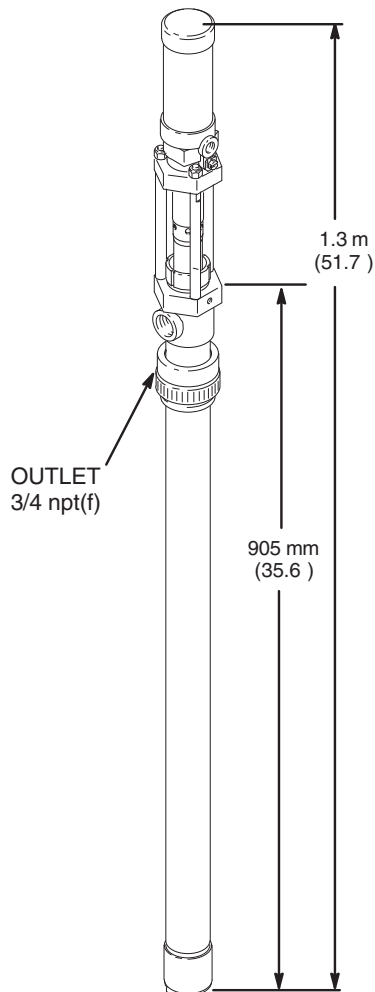

Graco Standard Warranty

Graco warrants all equipment manufactured by Graco and bearing its name to be free from defects in material and workmanship on the date of sale by an authorized Graco distributor to the original purchaser for use. With the exception of any special, extended, or limited warranty published by Graco, Graco will, for a period of twelve months from the date of sale, repair or replace any part of the equipment determined by Graco to be defective. This warranty applies only when the equipment is installed, operated and maintained in accordance with Graco's written recommendations.

This warranty does not cover, and Graco shall not be liable for general wear and tear, or any malfunction, damage or wear caused by faulty installation, misapplication, abrasion, corrosion, inadequate or improper maintenance, negligence, accident, tampering, or substitution of non-Graco component parts. Nor shall Graco be liable for malfunction, damage or wear caused by the incompatibility of Graco equipment with structures, accessories, equipment or materials not supplied by Graco, or the improper design, manufacture, installation, operation or maintenance of structures, accessories, equipment or materials not supplied by Graco.

This warranty is conditioned upon the prepaid return of the equipment claimed to be defective to an authorized Graco distributor for verification of the claimed defect. If the claimed defect is verified, Graco will repair or replace free of charge any defective parts. The equipment will be returned to the original purchaser transportation prepaid. If inspection of the equipment does not disclose any defect in material or workmanship, repairs will be made at a reasonable charge, which charges may include the costs of parts, labor, and transportation.

THIS WARRANTY IS EXCLUSIVE, AND IS IN LIEU OF ANY OTHER WARRANTIES, EXPRESS OR IMPLIED, INCLUDING BUT NOT LIMITED TO WARRANTY OF MERCHANTABILITY OR WARRANTY OF FITNESS FOR A PARTICULAR PURPOSE.

Graco's sole obligation and buyer's sole remedy for any breach of warranty shall be as set forth above. The buyer agrees that no other remedy (including, but not limited to, incidental or consequential damages for lost profits, lost sales, injury to person or property, or any other incidental or consequential loss) shall be available. Any action for breach of warranty must be brought within two (2) years of the date of sale.

Graco makes no warranty, and disclaims all implied warranties of merchantability and fitness for a particular purpose in connection with accessories, equipment, materials or components sold but not manufactured by Graco. These items sold, but not manufactured by Graco (such as electric motors, switches, hose, etc.), are subject to the warranty, if any, of their manufacturer. Graco will provide purchaser with reasonable assistance in making any claim for breach of these warranties.

In no event will Graco be liable for indirect, incidental, special or consequential damages resulting from Graco supplying equipment hereunder, or the furnishing, performance, or use of any products or other goods sold hereto, whether due to a breach of contract, breach of warranty, the negligence of Graco, or otherwise.

FOR GRACO CANADA CUSTOMERS

The parties acknowledge that they have required that the present document, as well as all documents, notices and legal proceedings entered into, given or instituted pursuant hereto or relating directly or indirectly hereto, be drawn up in English. Les parties reconnaissent avoir convenu que la rédaction du présente document sera en Anglais, ainsi que tous documents, avis et procédures judiciaires exécutés, donnés ou intentés à la suite de ou en rapport, directement ou indirectement, avec les procédures concernées.

Graco Information

TO PLACE AN ORDER, contact your Graco distributor, or call one of the following numbers:

Toll Free Phone Number: 1-800-328-0211

All written and visual data contained in this document reflects the latest product information available at the time of publication.

Graco reserves the right to make changes at any time without notice.

Sales Offices: Minneapolis, Detroit
International Offices: Belgium, Korea, Hong Kong, Japan

www.graco.com

PRINTED IN THE USA 307552 05/1982, Revised 10/2024