



FUSION FX™

Breakthrough Spray Gun Technology
Designed to Deliver the Highest Quality Results



PROVEN QUALITY. LEADING TECHNOLOGY.



INTRODUCING FUSION FX

THE SMALLEST, LIGHTEST, BEST BALANCED GUN EVER BUILT

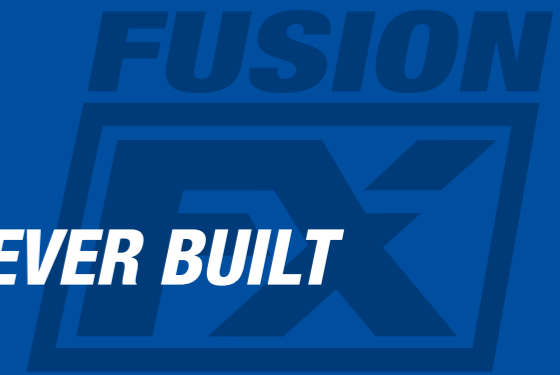

THE MOST COMFORTABLE SPRAY EXPERIENCE YOU CAN HAVE

SMALLEST GUN ON THE MARKET

- Narrow design and tapered diameter makes spraying in tight spots easier

LIGHTEST GUN ON THE MARKET

- Over 30% lighter compared to Fusion PC.

MOST BALANCED GUN ON THE MARKET

- The most balanced gun in your hand with hoses attached. Over 9X better balanced compared to its predecessors.

FUSION FX (FLEXIBLE XCHANGE) SPRAY TECHNOLOGY

DUOFLO™ VALVING

ProConnect® cartridge design for a perfect rebuild in seconds. DuoFlo valving eliminates side seals and provides precision control and mixing.

RAPIDSWAP™ MIX CHAMBER

Game changing design provides access to the mix chamber in seconds without disassembling the gun. Quickly change mix chamber sizes to match your application and easily keep your impingement ports clean.

QUICKFLEX™ TECHNOLOGY

Switch effortlessly between ClearShot™ and Air Purge modes by easily swapping the air piston, giving you the flexibility to tackle any project with confidence.

NEW TECHNOLOGY THAT WILL CHANGE THE WAY YOU SPRAY

- Access mix chamber in seconds without disassembling the gun
- DuoFlo valving and stationary mix chamber eliminate the need for side seals
- Over 30% shorter trigger pull
- Access to gun filters without removing the hose manifold
- Tool-less fluid valves
- Swap between Air Purge and ClearShot spraying

FX CARTRIDGE

- ProConnect design for fast and simple gun rebuilds
- DuoFlo valving technology eliminates side seals
- Precision control and mixing

AIR CAP/MIX CHAMBER

- Removable air cap provides quick access to mix chamber without disassembling the gun
- Easily swap mix chamber size to best match your spray application

HOSE MANIFOLD

- New lightweight aluminum hose manifold
- Ball checks included to prevent chemical leakage from manifold
- New tool-less manual valves

GUN FILTERS

- Easy access to gun filters without removing the hose manifold
- Larger screens to prevent nuisance clogging

TRIGGER

- Over 30% shorter trigger pull for improved responsiveness and reduced fatigue
- Wider trigger designed for improved comfort

QUICKFLEX SPRAY TECHNOLOGY

- Gun designed to be easily converted between CS and AP spraying
- Handle designed for both ClearShot fluid or Air Purge use
- Utilizes existing CS Fluid tubes

FX GUN DESIGN

- Small sculpted gun design allows for easy access to small areas
- Lightweight balanced feel for reduced fatigue

ON/OFF KNOB

- New positive stop on/off knob
- ¼ turn easily shuts off flow
- Knob aligned up/down = material is flowing
- Knob aligned left/right = material is shut off

TOOL-LESS MANUAL VALVES

- New wing nut design allows valves to be open and closed by hand or with standard nutdriver

HAND STRAP

- Designed to reduce sprayer fatigue and required grip strength when holding the gun
- Easy to adjust or remove by the sprayer

HANDLE

- Glass filled nylon design for lightweight ergonomics
- Temperature stable
- Great strength and heat resistance
- Larger, ergonomic design for improved comfort and reduced fatigue

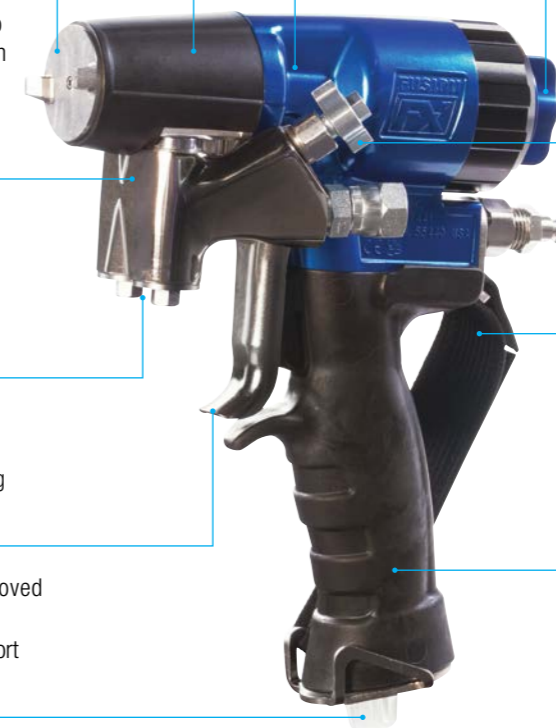

FX CARTRIDGE DUOFLO VALVING TECHNOLOGY

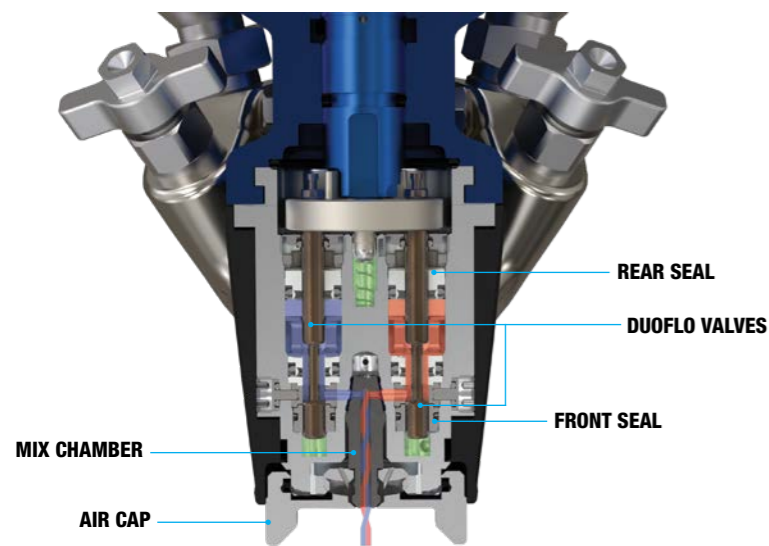

FULLY TRIGGERED: VALVES OPEN

- A & B Fluid Open
- Purge Air/CS Closed

PROCONNECT

- Provides a perfect rebuild in seconds

DUOFLO VALVING TECHNOLOGY

- Precision dispensing without side seals

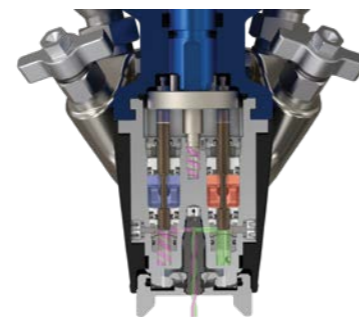

NOT TRIGGERED: VALVES CLOSED

- A & B Fluid Closed
- Purge Air/CS Open

■ ISO
 ■ RESIN
 ■ CS FLUID
 ■ PURGE AIR



FX CARTRIDGE: FRONT

- Easy access to RapidSwap Mix Chamber
- Small diameter for spraying in tight locations
- Small holes provide clean-off air to air cap



FX CARTRIDGE: BOTTOM

- Check valves allow for clean attachment to hose manifold and help reduce the impact of fluid cross-overs
- Fluid weep holes for early detection when a cartridge should be replaced



FX CARTRIDGE: REAR

- Simple attachment to Air Piston
- Fluid connection when using CS Fluid
- Easy access to DuoFlo valves



SCAN TO SEE
FLUID ANIMATION

MIX CHAMBER / AIR CAP RAPIDSWAP MIX CHAMBER

COMPLETELY REDESIGNED TO MAKE SPRAYING EASIER

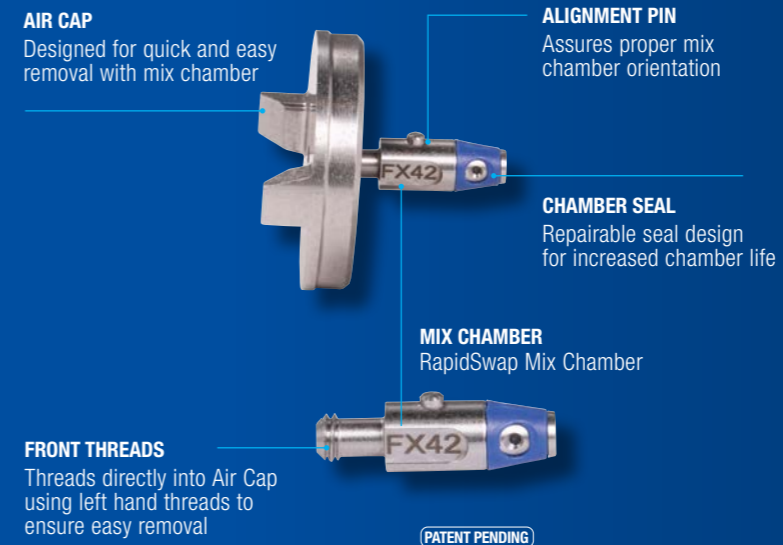

- The new RapidSwap chamber allows you to quickly and easily change mix chamber sizes
- Fast access to impingement ports for easy cleaning

MORE OUTPUT

- FX chambers have more output due to less pressure drop through the gun

LONGEST LIFE

- New stationary mix chamber has no external wear surfaces since the FX gun does not use side seals

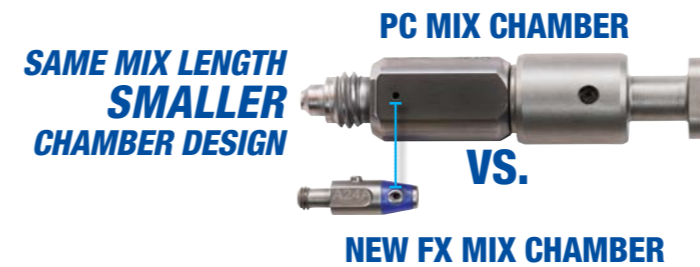

QUICK AND EASY RAPIDSWAP CHAMBER PROCESS



STEP 1
Insert chamber into FX cartridge, making sure alignment pin is at the 12:00 position



STEP 2
Hand tighten so the tip of the mix chamber is flush with the air cap



STEP 3
Snug air cap tight using a tool to ensure the mix chamber is properly sealed



QUICKFLEX TECHNOLOGY

Fusion FX can be sprayed utilizing either ClearShot or Air Purge modes

PATENT PENDING

DESIGNED FOR EASY CONVERSION BETWEEN CLEARSHOT AND AIR PURGE SPRAY MODES

UTILIZE

- ClearShot for reduced drilling and improved pattern retention. Most effective when spraying closed cell foams.
- Air Purge for traditional spraying, most effective for applying open cell foams and polyureas.

EASILY CONVERT BETWEEN CS AND AP

- Simply swap air pistons to change between CS and AP modes. Both air pistons included with the bare gun and foam gun part numbers.



CS Air Piston



AP Air Piston



Fusion FX spray foam gun kit FX9001

FUSION FX ORDERING INFORMATION

FX GUNS

PART #	DESCRIPTION
FX9000*	Fusion FX: Bare gun, includes CS and AP parts. No mix chamber included.

FX Gun with common spray foam chambers included

FX9001*	Fusion FX spray foam gun kit with mix chamber sizes 37, 42, 47 included
---------	---

FX Gun with common polyurea chambers included

FX9011**	Fusion FX polyurea gun kit, with mix chamber sizes 29, 34, 37 included
----------	--

* Includes: gun configured as a CS gun with AP parts included, 2 FX Cartridges, CS Fluid 6-pack, Tools and Accessories.

** Includes: gun configured as an AP gun, 2 FX Cartridges, additional AP air piston, Tools and Accessories. No CS parts included.

MIX CHAMBERS

Round Mix Chambers

PART #	DESCRIPTION
FX20RD	FX round mix chamber with 0.020 orifices (000)
FX29RD	FX round mix chamber with 0.029 orifices (00)
FX34RD	FX round mix chamber with 0.034 orifices
FX37RD	FX round mix chamber with 0.037 orifices
FX42RD	FX round mix chamber with 0.042 orifices (01)
FX47RD	FX round mix chamber with 0.047 orifices
FX52RD	FX round mix chamber with 0.052 orifices (02)
FX60RD	FX round mix chamber with 0.060 orifices (03)
FX70RD	FX round mix chamber with 0.070 orifices (04)

FX chambers have more output due to less pressure drop through the gun. For chamber sizes: 37, 42, 47, 52 it is recommended to downsize one chamber size for similar output to AP/PC chambers.

ACCESSORIES

PART #	DESCRIPTION
2000810	FX Cartridge - 1 Pack
2000811	FX Cartridge - 3 Pack
2000812	FX Cartridge - 5 Pack
2000788	Round Air Cap
2005269	Pour Air Cap
2005266	Extension Tip Cap: 34-42
2005267	Extension Tip Cap: 37-47
2005268	Extension Tip Cap: 52-70
256385	ClearShot Liquid – 25 pack
256386	ClearShot Liquid – 50 pack
256387	ClearShot Liquid – 100 pack
17X756	Bulk CS Fluid, 4 pack, 0.47 liter bottle (can fill 100 CS tubes)
17X757	Bulk CS Fluid, 12 pack, 0.47 liter bottle (can fill 300 CS tubes)

KITS

PART #	DESCRIPTION
2006566	Fusion FX Parts Kit, Complete - Refillable Case
2001033	Complete O-Ring Kit
2001029	FX Cartridge O-Ring Kit
2001027	DuoFlo Valving Repair Kit
2000716	Hand Strap Kit includes upper and lower strap brackets
21A018	Replacement Hand Strap
2000975	FX Fluid Manifold Valve Kit
2001025	Iso Filter Kit
2001026	Resin Filter Kit
24R894	Gun Filter Kit – 10 pack
2005366	Mix Chamber Seal Kit – 10 pack
2005061	FX Clean-Out Tool Kit – 5 pack
2000972	Polymer Handle Kit
2002347	FX to AP/PC Adapter Manifold and Hose Kit



VISIT GRACO.COM/FUSIONFX TO LEARN MORE





OUR BRAND PROMISE TO YOU

Since 1926, **innovation**, **quality** and **A+ Service** have been at the centre of Graco.

Experience Innovation

Our focus on innovation results in products and equipment that lead the industry with technologically-advanced features, pioneering design, high performance and unparalleled reliability. In short, innovation is how you get better products!

Building Quality

You're investing in high-quality products built to last for years of reliable service. Moreover, we partner with our customers to better understand how you're deploying our products in the field, then use your experiences to improve performance and durability.



A+ service, every time

You'll see A+ Service in action when you contact any of our support services options no matter where you are in the world. We'll listen to your situation and work methodically to resolve it as quickly as we can. We are guided by a mindset of integrity and a customer service view centred on collaboration and relationships, not transactions.



We're here to answer questions and help address your needs:

www.graco.com/contact

Graco is certified ISO 9001.

©2024 Graco Distribution BV 3J0630ENEU-A 08/24. Printed in Europe.

All written and visual data contained in this document are based on the latest product information available at the time of publication. Graco reserves the right to make changes at any time without notice.

All other brand names or marks are used for identification purposes and are trademarks of their respective owners. For more information on Graco's intellectual property, see www.graco.com/patent or www.graco.com/trademarks.