

# ADM Token In-System Programming

3A6321A

EN

*For transferring system software updates from USB drives to Graco software update tokens using an Advanced Display Module. For professional use only.*

**Not approved for use in explosive atmospheres or hazardous locations.**



## **Important Safety Instructions**

Read all warnings and instructions in this manual and your system manuals before using the equipment. Save these instructions.

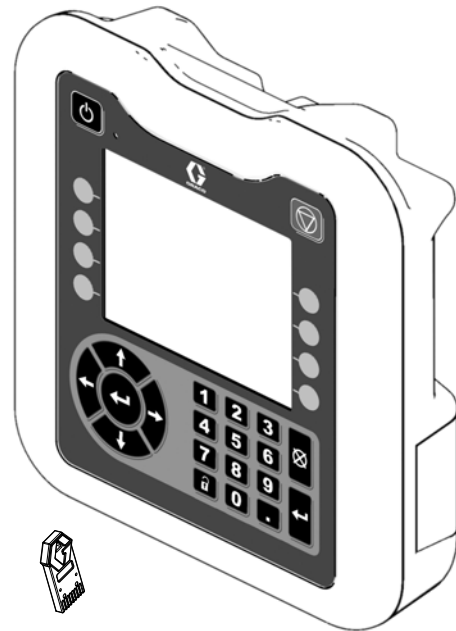

# Contents

- Related Manuals** ..... 2
- Overview** ..... 2
- Component Identification** ..... 3
- Setup** ..... 4
- Operation** ..... 5
  - Obtain Software Updates ..... 5
  - System Software View ..... 5
  - Software Transfer Procedure ..... 7

# Related Manuals

Manual	
Part	Description
3A1244	Graco Control Architecture™ Module Programming

# Overview

ADM Token In-System Programming provides the capability to transfer software updates from a USB drive to a Graco black software update token. With this feature, you can obtain the software updates online, download them to the USB, and transfer them directly to the token instead of waiting for a new software update token to be shipped.

The Advanced Display Module (ADM) can be used to re-purpose any existing black software update token.

**NOTE:** This process is for Graco black tokens only; not Graco blue tokens.

**NOTE:** All update files must have a file extension of \*.GTI (software update files) or \*.GMI (gateway map files). A maximum of 14 files can be present in the \Graco\Software\ folder.

# Component Identification

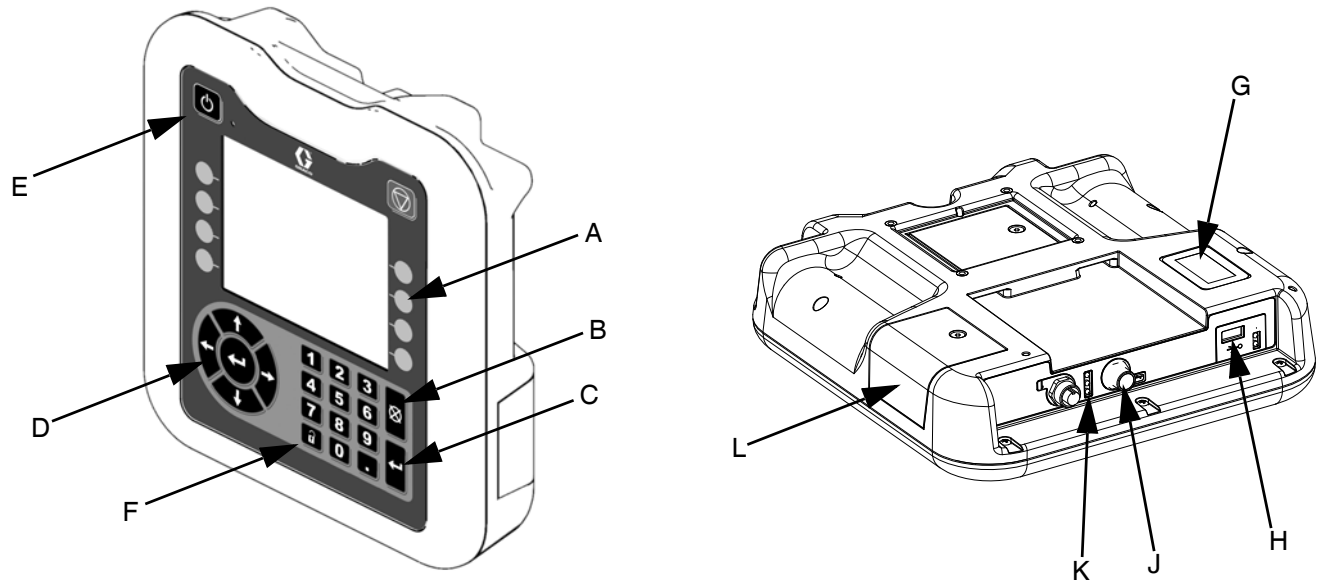

**FIG. 1: ADM Component Identification - Front and Rear Views**

**Key:**

**A Soft Keys**

Defined by the icon on the screen next to the soft key.

**B Cancel**

Cancel a selection.

**C Enter**

Acknowledge making a selection.

**D Directional Keypad**

Navigate within the screen.

**E Power Button**

Turn the system ON/OFF.

**F Lock/Setup Button**

Provide access to the setup screen.

**G Part Number Identification Label**

**H USB Interface**

Location for inserting the USB drive.

**J CAN/Power Cable Connection**

Communication and power connection.

**K Module Status LEDs**

Visual indicators to show the operational status of the ADM.

**L Token Access Cover**

Access cover over the location where the software update token is inserted.

# Setup

**NOTE:** Letters in parentheses are used in this section for reference to the callouts in **Figure 1** on page 3.

1. Place the ADM face down on a flat surface and remove the token access cover (L) as shown in **Figure 2**.

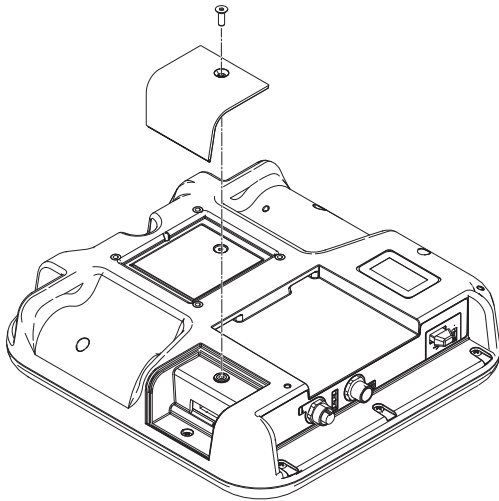

**FIG. 2: Remove Token Access Cover**

---

2. Turn the ADM face up.
3. Supply electrical power to the ADM using either system power or Power Supply Kit No. 24F672, which is available separately.

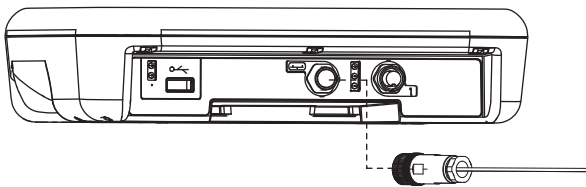

**FIG. 3: Connecting Power using Kit 24F672**

---

**NOTE:** The ADM starts and is ready for use when power is supplied.

# Operation

**NOTICE**

To prevent damage to the ADM's buttons, do not press the buttons with sharp objects such as pens, plastic cards, or fingernails.

**NOTE:** Letters in parentheses are used in this section for reference to the callouts in **Figure 1** on page 3.

## Obtain Software Updates

Use a computer with Internet access to obtain software updates.

1. Insert the USB drive into a USB port on your computer.
2. Open your Internet browser and go to help.graco.com.
3. Navigate to the desired software update.
4. Save the GTI or GMI software update file to the \GRACO\SOFTWARE\ folder on the USB drive.

**NOTE:** To create this folder automatically on the USB drive, insert the USB into the ADM and press the soft

key (A) next to the Software Update  icon on the System Software screen. See **Figure 4**.

**NOTE:** Limit the number of software update files in the USB's folder to 14. The ADM's software can only display the first 14 updates found. Refer to **Figure 9** on page 7 for inserting the USB.

5. When completed, exit your browser and remove the USB drive from the computer.

## System Software View

When power is supplied to the ADM, press the setup button (F). Then press the left or right directional keys (D) to navigate to the Advanced settings.

Press the up directional key (D) to advance to the System Software screen (4) as shown in **Figure 4**. This displays the system software part number and software version.

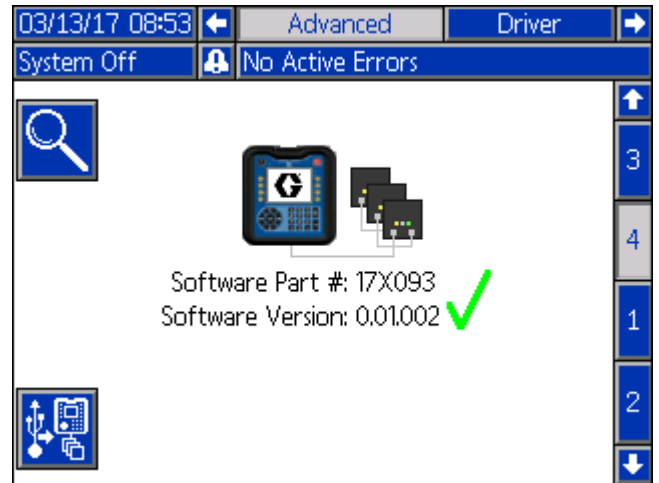



**FIG. 4: System Software Screen**

Pressing the soft key (A) next to the  icon allows you to view the software details for each module.

Pressing the soft key (A) next to the  icon initiates updating the system software using the USB.

A  indicates all modules are in sync with the system version.

An  indicates one or more of the modules contains software that differs from what is expected. If this occurs, a red box will flash around the  icon.

### Software Details

To show the software details for each module, press the

soft key (A) next to the  icon on the System Software screen. This displays the System Software Details

screen as shown in **Figure 5**. The  indicates each model has software matching the software version.

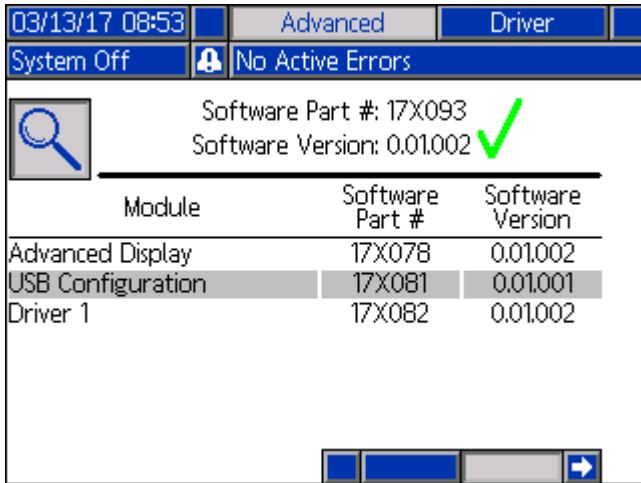
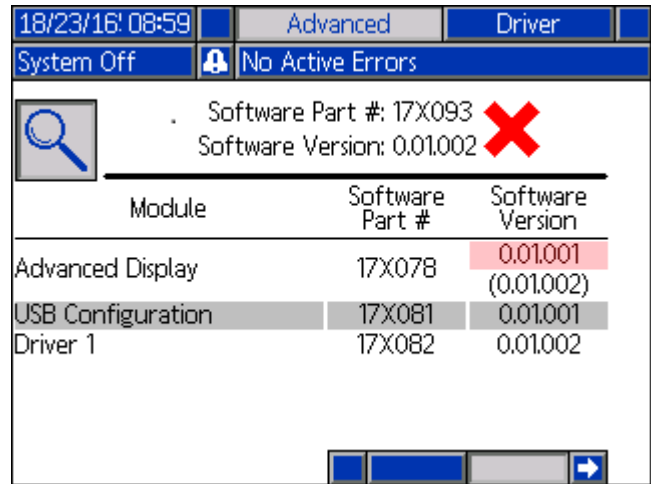

**FIG. 5: System Software Details Screen**

The left and right arrows on the System Software Details screen are used to scroll through the details of each module.

The column header for the serial number of the module is shown as: .

As shown in **Figure 6**, the  indicates a software mismatch was detected.



**FIG. 6: Software Mismatch**

The software that is mismatched is highlighted in light red. The software that is expected is shown below it in parentheses.

17P796	3.01.004
(15U193)	(2.06.004)

Press the soft key (A) next to the  icon to return to the previous screen.

# Software Transfer Procedure

Press the soft key (A) next to the  icon on the System Software screen to begin. Then follow the on-screen prompts on the Software Update Start screen shown in **Figure 7**.

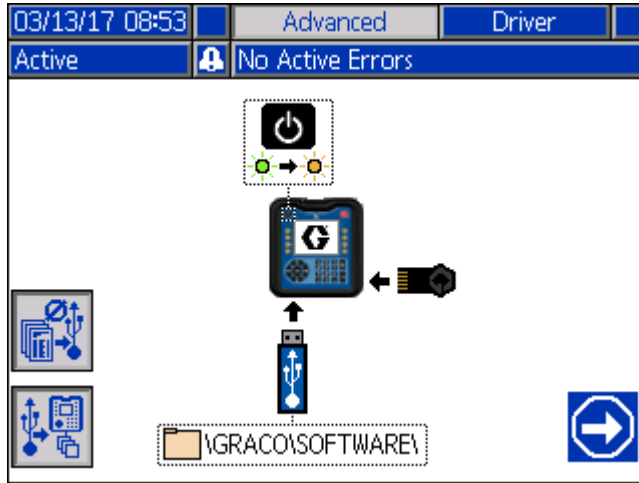



**FIG. 7: Software Update Start Screen**

Pressing the soft key (A) next to the  icon disables the upload/download options for USB logs, system settings, and custom language files. Upload/download

options are disabled when the icon appears gray .

**NOTE:** Disabling the upload/download options allows for a faster software transfer procedure. However, a factory reset to default settings is possible during the software transfer procedure. It is recommended that upload/download options remain enabled if any data logs, system settings, and custom language files are critical. Upload/download options are enabled when the

icon appears blue .

Pressing the soft key (A) next to the  icon exits the USB update screen.

1. Press the Power button (E) to turn off the system.

**NOTE:** If power is cycled while a token is present, the system tries to load the software that is currently loaded on the token. If you are inserting a token that contains older software, do not cycle power and inadvertently load the old software. Depending on the age of the software, it may not be possible to reprogram a token.

2. Insert a black update token into the slot where the cover (L) was removed as shown in **Figure 8**.

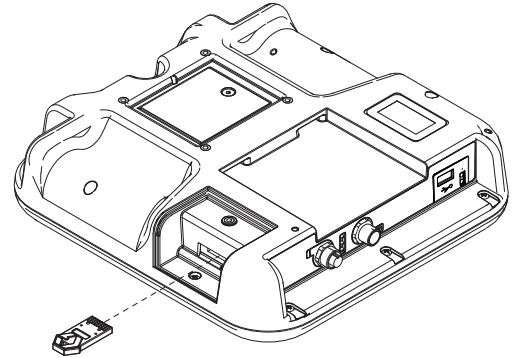

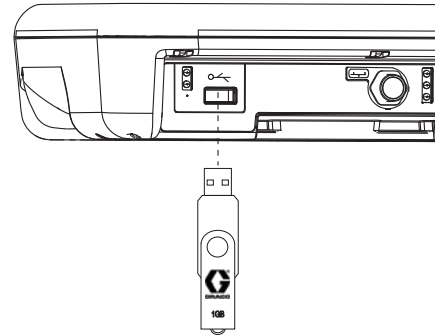

**FIG. 8: Insert Token**

3. Insert a USB drive into the USB interface slot (H) as shown in **Figure 9**. A warning may flash on the screen signaling that a USB download is occurring. If this happens, wait for the warning to indicate that the USB download is complete. Press the Enter key (C) to return to the Software Update Start screen.



**FIG. 9: Insert USB Drive**

**NOTE:** An hour glass icon shows on the Software Update Start screen while the USB drive is preparing for the software transfer process. If this process takes more than a couple of minutes, remove the USB drive and try again.  

**NOTE:** The following message is displayed if no compatible software files are found on the USB drive:

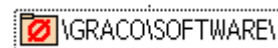

- When the process is ready to begin, the screen automatically transitions to the USB Software Update screen shown in **Figure 10**.

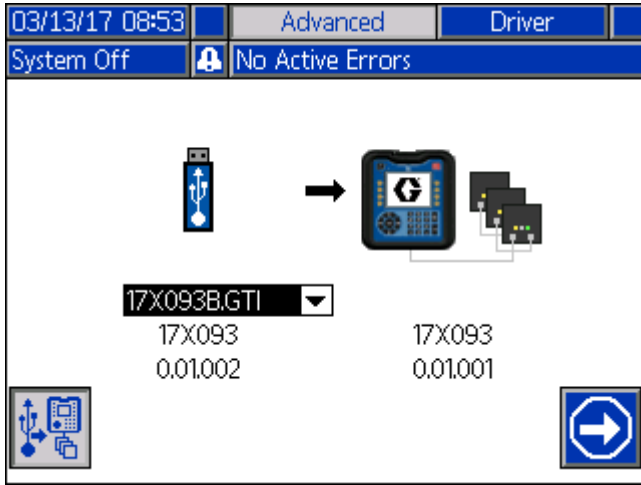
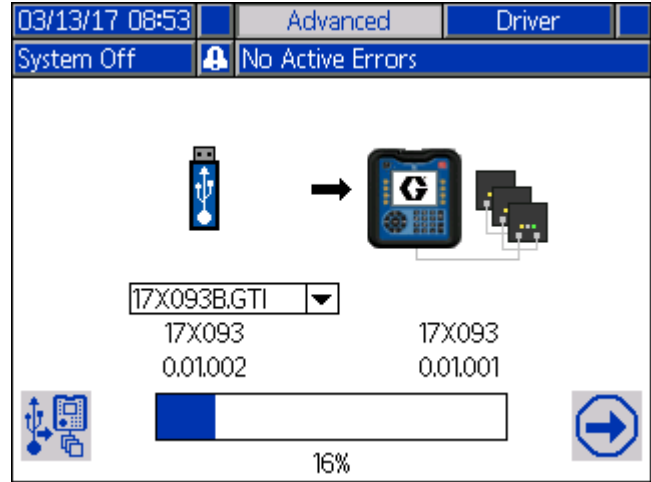

**FIG. 10: USB Software Update Screen**

**NOTE:** The screen has a drop down box on the left side that allows you to select the software update file from the USB drive. The software part number and version for the update is listed beneath the file. The right side of the screen shows the current software part number and version on the token.

- Press the ADM's Enter key (C) to change the selection on the USB drive. This opens the drop down menu showing the available software update files (up to 14 files).
- Use the directional keypad (D) to highlight the desired update and press the Enter key (C) to select the update.
- Press the soft key (A) next to the Continue  icon to begin the software transfer. In the example in **Figure 10**, software version 0.01.002 of the 17X093 software will be copied from the USB drive and will overwrite version 0.01.001 of 17X083 on the token.

**NOTE:** The progress of writing the software update to the token is shown on the screen in **Figure 11**. This could take several minutes to complete. Leave the USB drive and token inserted while the transfer is in progress. The ADM's buttons are not functional during this time.



**FIG. 11: Software Transfer Progress**

- When the transfer is complete, the progress bar will be solid blue and 100% will be displayed as shown in **Figure 12**. Remove the USB drive and token from the ADM.

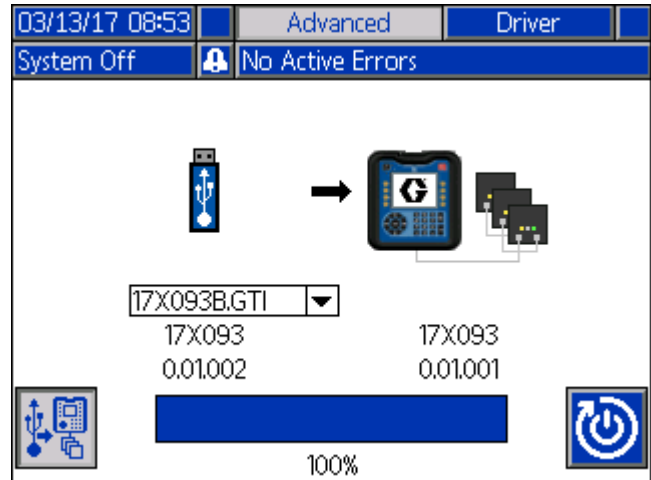

**FIG. 12: Software Transfer Complete**

- After the transfer is complete, press the soft key (A) next to the  icon. This automatically resets the ADM to load software. Refer to manual 3A1244 for step-by-step instructions on how to update the software version of Graco Control Architecture Modules. See **Related Manuals** on page 2.



**NOTE:** The system must be manually reset to load a \*.GMI file. Follow your system manual to load a new version of the gateway map.

10. If the software update transfer fails, the progress bar turns red and no percentage is shown. See **Figure 13**. Make sure the token and USB are inserted correctly (not loose) and retry the procedure. Do not remove the USB drive or token until the transfer process is complete. Press the soft key (A) next to the



icon to reattempt a software transfer.

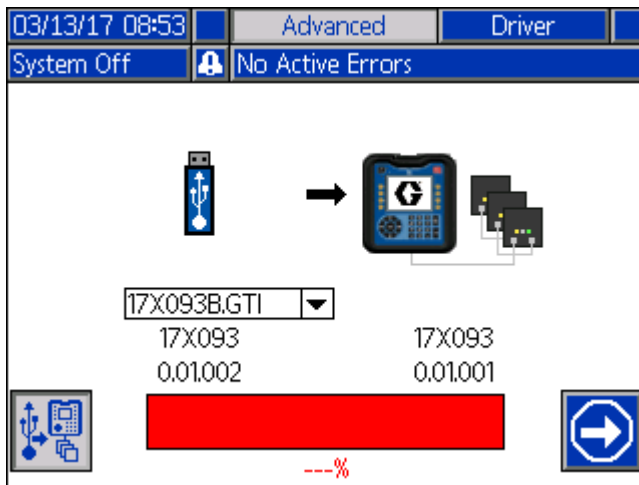

**FIG. 13: Software Transfer Not Completed**

**NOTE:** When the software transfer is completed successfully, the ADM powers up as normal. You can repeat the procedure with another token if needed.

# Graco Information

## Sealant and Adhesive Dispensing Equipment

For the latest information about Graco products, visit [www.graco.com](http://www.graco.com).

For patent information, see [www.graco.com/patents](http://www.graco.com/patents).

**TO PLACE AN ORDER, contact your Graco distributor, go to [www.graco.com](http://www.graco.com) and select “Where to Buy” in the top blue bar, or call to find the nearest distributor.**

***If calling from the US: 800-746-1334***

***If calling from outside the US: 0-1-330-966-3000***

*All written and visual data contained in this document reflects the latest product information available at the time of publication.  
Graco reserves the right to make changes at any time without notice.*

Original instructions. This manual contains English. MM 3A6321

**Graco Headquarters:** Minneapolis

**International Offices:** Belgium, China, Japan, Korea

**GRACO INC. AND SUBSIDIARIES • P.O. BOX 1441 • MINNEAPOLIS MN 55440-1441 • USA**  
**Copyright 2016, Graco Inc. All Graco manufacturing locations are registered to ISO 9001.**

[www.graco.com](http://www.graco.com)

Revision A, September 2018