

# Instructions–Parts List



55 GALLON (200 LITER) DRUM SIZE

310572D

## Air–Powered Ram

ENG

*For sanitary application. For professional use only. Not for use in explosive atmospheres.*

*100 psi (0.7 MPa, 7 bar) Maximum Working Pressure*

**Part No. 234015, Series B**

**Part No. 24B921, Series A**

**Part No. 954285, Series A**



### **Important Safety Instructions**

Read all warnings and instructions in this manual.  
Save these instructions.

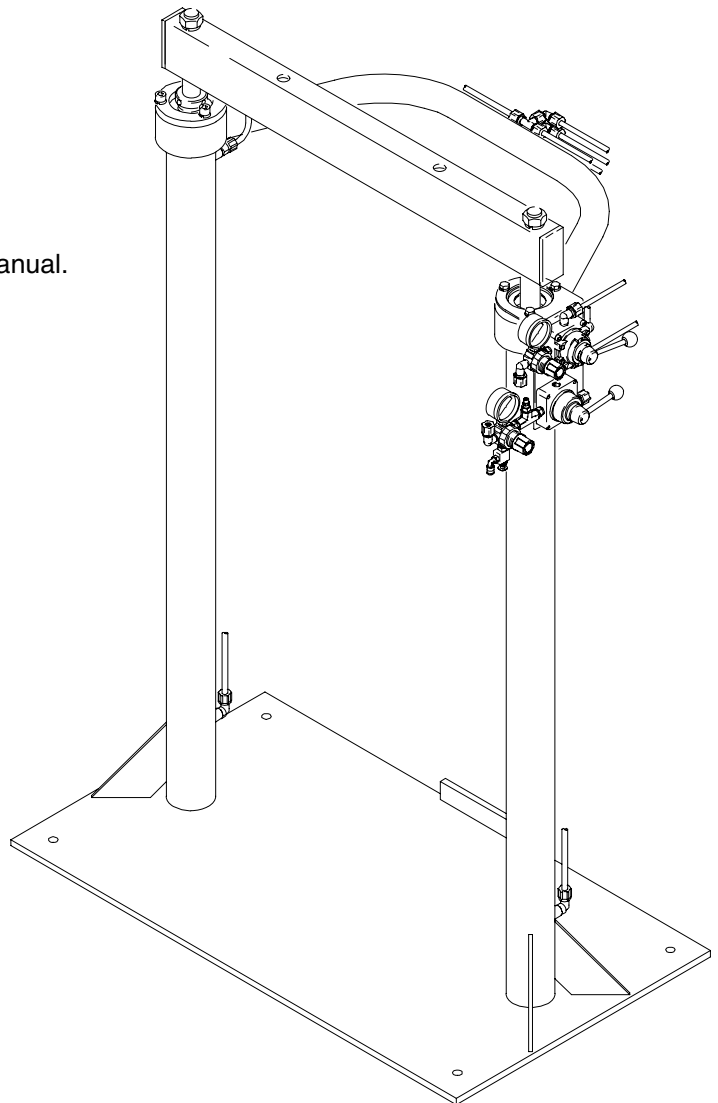

T12223C

# Table of Contents

Warnings .....	2
Setup .....	4
Operation .....	6
Troubleshooting .....	9
Service .....	10
Parts .....	12
Dimensions .....	14
Technical Data .....	14
Graco Standard Warranty .....	16
Graco Information .....	16

# Symbols

## Warning Symbol





This symbol alerts you to the possibility of serious injury or death if you do not follow the instructions.

## Caution Symbol



This symbol alerts you to the possibility of damage to or destruction of equipment if you do not follow the instructions.

 <b>WARNING</b>	
 <b>INSTRUCTIONS</b>	<p><b>EQUIPMENT MISUSE HAZARD</b></p> <p>Equipment misuse can cause the equipment to rupture or malfunction and result in serious injury.</p> <ul style="list-style-type: none"> <li>● This equipment is for professional use only.</li> <li>● Read all instruction manuals, tags, and labels before operating the equipment.</li> <li>● Use the equipment only for its intended purpose. If you are not sure, call your Graco distributor.</li> <li>● Do not alter or modify this equipment.</li> <li>● Check equipment daily. Repair or replace worn or damaged parts immediately.</li> <li>● Do not exceed the maximum working pressure stated on the equipment or in the <b>Technical Data</b> for your equipment. Do not exceed the maximum working pressure of the lowest rated component in your system.</li> <li>● Wear hearing protection when operating this equipment.</li> <li>● Comply with all applicable local, state, and national fire, electrical, and safety regulations.</li> </ul>
	<p><b>MOVING PARTS HAZARD</b></p> <p>Moving parts, such as the pump's priming piston and the ram plate, can pinch or amputate your fingers.</p> <ul style="list-style-type: none"> <li>● Keep clear of all moving parts when starting or operating the pump.</li> <li>● Keep hands and fingers away from the priming piston during operation and whenever the pump is charged with air.</li> <li>● Keep your hands away from the ram plate and the lip of the drum while the ram is operating.</li> <li>● Before servicing the equipment, follow the <b>Pressure Relief Procedure</b> on page 6 to prevent the equipment from starting unexpectedly.</li> </ul>



# Setup

## General Information

**NOTE:** Reference numbers and letters in parentheses in the text refer to the callouts in the figures and the parts drawing.

Accessories are available from Graco. Make certain all accessories are adequately sized and pressure-rated to meet your system's requirements.

Fig. 1 is only a guide for selecting and installing system components and accessories. Contact your Graco distributor for assistance in designing a system to suit your particular needs.

## Location

Position the ram so the air regulators for the pump and the ram will be easily accessible. Ensure that there is sufficient overhead clearance when the ram is fully raised. Refer to **Dimensions** on page 14.

Using the holes in the ram base as a guide, drill holes for 1/2 in. (13 mm) anchors.

Check that the ram base is level in all directions. If necessary, level the base using metal shims. Secure the base to the floor using 13 mm (1/2 in.) anchors which are long enough to prevent the ram from tipping.

## Components and Accessories

Refer to Fig. 1.

### **WARNING**

A main air bleed valve (E) and pump air bleed valve (H) are required. These accessories help reduce the risk of serious injury, including fluid injection and splashing of fluid in the eyes or on the skin, and injury from moving parts if you are adjusting or repairing the pump.

The main air bleed valve (E) shuts off and relieves the air to the pump and ram. The ram will hold pressure if the ram director valve (U) is in the horizontal (neutral) position. To relieve air pressure in the ram, close the main air bleed valve (E) and move the director valve (U) to RAM DOWN. The ram will slowly drop.

The pump air bleed valve (H) relieves air trapped between it and the pump after the air is shut off. Trapped air can cause the pump to cycle unexpectedly. Locate the valve close to the pump.

- **The main air bleed valve (E)** is required in your system to shut off the air supply to the pump and ram (see the **WARNING** at left). When closed, the valve will bleed off all air in the ram and pump, and the ram will slowly drop. Be sure the valve is easily accessible from the pump, and is located **upstream** from the air manifold (F).
- **The pump air bleed valve (H)** is required in your system to relieve air trapped between it and the air motor when the valve is closed (see the **WARNING** at left). Be sure the valve is easily accessible from the pump, and is located **downstream** from the pump air regulator (G).
- **The pump air regulator (G)** controls pump speed and outlet pressure by adjusting the air pressure to the pump. Locate the regulator close to the pump, but **upstream** from the pump air bleed valve.
- **The air manifold (F)** has a swivel air inlet. Provides ports for connecting lines to air-powered accessories.
- **An air line filter (J)** removes harmful dirt and moisture from the compressed air supply. Also, install a **drain valve (W)** at the bottom of each air line drop, to drain off moisture.
- **The ram air regulator (T)** controls the air pressure to the ram.
- **The ram director valve (U)** controls the raising and lowering of the ram.
- **The inflatable seal air regulator (CC)** controls air pressure to the ram plate seal.
- **The inflatable seal director valve (DD)** controls the raising and lowering of the ram plate.
- **The fluid drain valve (EE)** (required in your system) relieves fluid pressure between the pump and dispense device.

# Setup

## KEY

- A Pump
- B Ram
- C Wiper Plate
- D Electrically Conductive Air Supply Hose
- E Main Air Bleed Valve (required, for pump and ram)
- F Air Manifold

- G Pump Air Regulator
- H Pump Air Bleed Valve (required for pump)
- J Air Line Filter
- T Ram Air Regulator
- U Ram Director Valve

- Y Pump Ground Wire (required)
- W Air Line Drain Valve
- CC Inflatable Seal Air Regulator
- DD Inflatable Seal Director Valve
- EE Fluid Drain Valve (required for pump)
- FF Blow-off Switch (ram up assist)

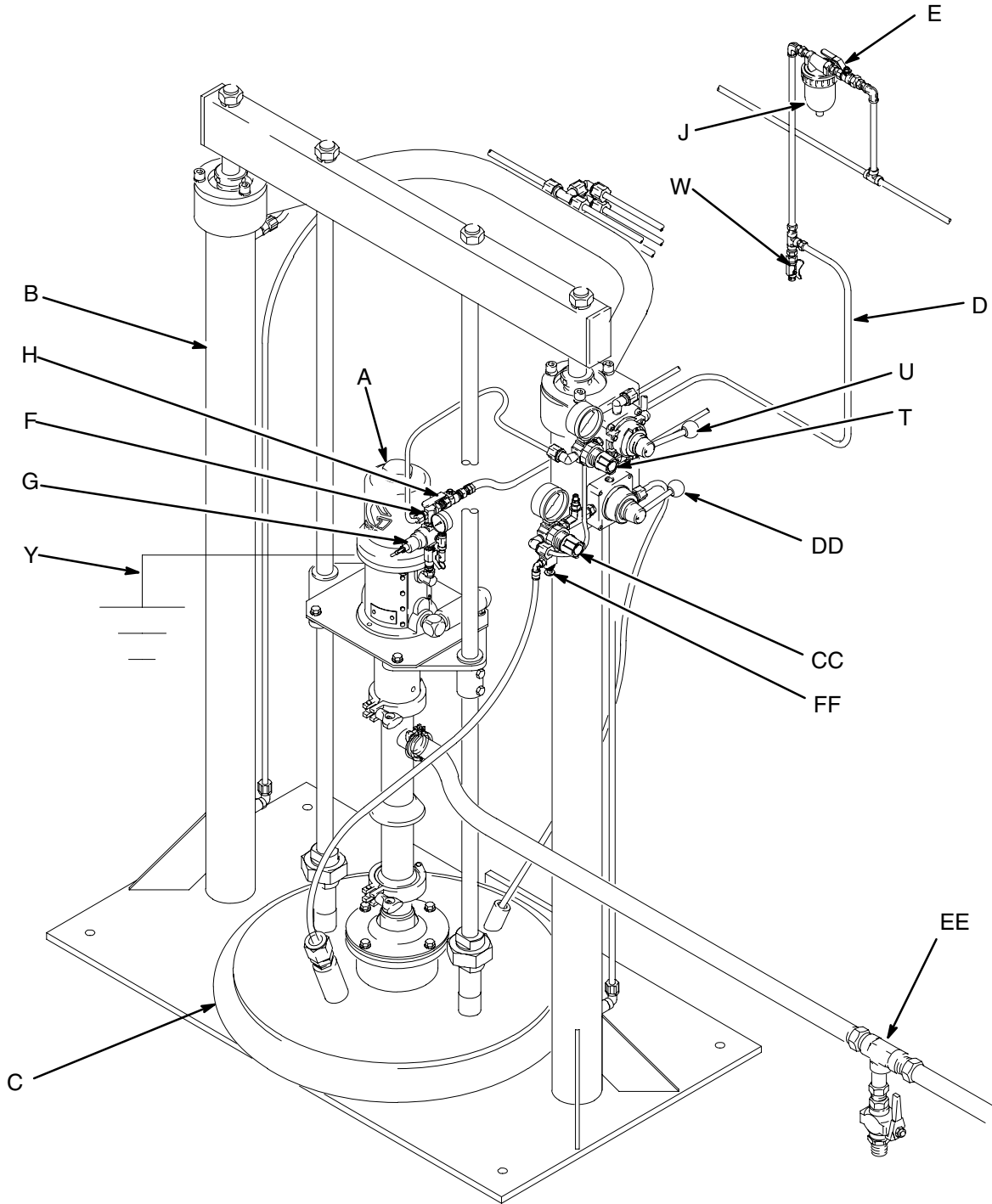

Fig. 1

T12260C

# Operation

## Pressure Relief Procedure

### **WARNING**



#### **INJECTION HAZARD**

The system pressure must be manually relieved to prevent the system from starting or spraying accidentally. Fluid under high pressure can be injected through the skin and cause serious injury. To reduce the risk of an injury from injection, splashing fluid, or moving parts, follow the **Pressure Relief Procedure** whenever you:

- are instructed to relieve the pressure,
- stop spraying/dispensing,
- check or service any of the system equipment,
- or install or clean the spray tip/nozzle.

1. Lock the gun/valve trigger safety.
2. Close the pump air bleed valve (H, required in your system).
3. Shut off the main air bleed valve (E, required in your system). Set the ram director valve (U) to RAM DOWN. The ram will slowly drop.
4. Unlock the gun/valve trigger safety.
5. Hold a metal part of the dispense device firmly to the side of a grounded metal pail, and trigger to relieve pressure.
6. Lock the gun/valve trigger safety.
7. Open the fluid drain valve (EE—required in your system), having a container ready to catch the drainage.
8. Leave the drain valve open until you are ready to spray again.

*If you suspect that the spray tip/nozzle or hose is completely clogged, or that pressure has not been fully relieved after following the steps above, very slowly loosen the tip guard retaining nut or hose end coupling and relieve pressure gradually, then loosen completely. Now clear the tip/nozzle or hose.*

## Starting and Adjusting the Ram

1. Refer to Fig. 2. Close all air regulators and air valves.
2. Open the main air bleed valve (E) and set the ram air regulator (T) to 40 psi (276 kPa, 2.8 bar). Pull up on the ram director valve (U) handle so the arrow points to RAM UP, and let the ram rise to its full height.
3. Set a full drum of fluid on the ram base, slide it back against the tube stop, and center it under the ram plate (C).

### **WARNING**



#### **MOVING PARTS HAZARD**

Moving parts can pinch or amputate your fingers. When the pump is operating and when raising or lowering the ram, keep your fingers and hands away from the pump intake, ram plate, and lip of the drum.

**NOTE:** Do not use drums that have side bungs or large dents with this ram. Rough bung openings or large dents will damage the wipers or stop the ram plate, resulting in a runaway pump.

4. Push down on the ram director valve handle so the arrow points to RAM DOWN, and lower the ram until the ram plate is just ready to enter the drum, then set the valve to neutral. Reposition the drum as necessary so the wipers will not hit the drum lip.
5. Set the director valve to RAM DOWN, and continue to lower the ram until the ram plate contacts the fluid. Inflate the seal to 10 psi (.07 MPa, 0.7 bar) to start.

**NOTE:** If fluid leaks past the seal, increase the air pressure to the seal gradually until leaking stops. To prevent overpressurization, a relief valve limits seal pressure to 25 psi (1.8 bar, 0.18 MPa).

# Operation

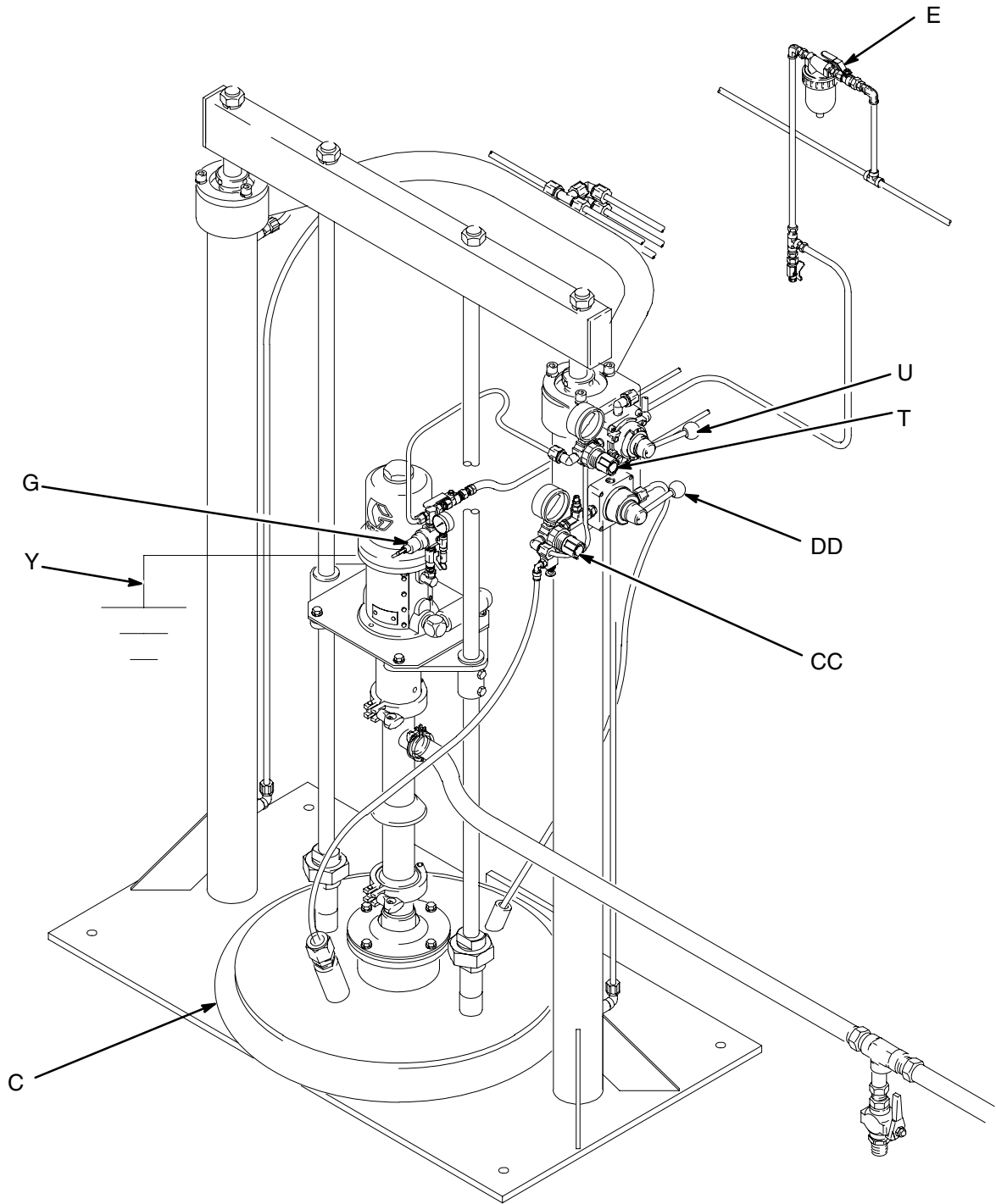

Fig. 2

T12260C

# Operation

## Starting and Adjusting the Pump

1. Be sure the pump air regulator (G) is closed. Then set the ram air regulator (T) to about 3.5 bar (50 psi). Set the ram director valve (U) to RAM DOWN. See Fig. 2.
2. Start the pump as explained in the separate pump instruction manual.
3. Keep the ram director valve (U) set to RAM DOWN while the pump is operating.

**NOTE:** Increase air pressure to the ram if the pump does not prime properly with heavier fluids. If fluid is forced out around the top wiper, ram pressure is too high and the air pressure should be decreased. Different combinations of seal and ram pressure may be necessary for proper seal and pump operation.

**NOTE:** For diaphragm pump models, adjust RAM DOWN pressure to the minimum level, to ensure that the pump inlet balls seat properly.

## Changing Drums

### **WARNING**



#### **MOVING PARTS HAZARD**

Moving parts can pinch or amputate your fingers. When the pump is operating and when raising or lowering the ram, keep your fingers and hands away from the pump intake, ram plate, and lip of the drum.

1. Stop the pump. **Close the pump air bleed valve (H).**
2. Set ram director valve (U) to RAM UP to raise ram plate.
3. Raise ram plate until it is completely out of drum.
4. Remove empty drum.
5. Inspect ram plate and, if necessary, remove any remaining material or material build-up.
6. Place full drum on ram base.
7. Lower the ram and adjust the position of the drum relative to the ram plate, as explained under “Starting and Adjusting the Ram” on page 6.

## Shutdown and Care of the Pump

1. Set the ram director valve (U) to neutral.

### **WARNING**

To reduce the risk of serious injury whenever you are instructed to relieve pressure, always follow the **Pressure Relief Procedure** on page 6.

2. **Relieve the pressure.**
3. Follow the pump shutdown instructions in your separate pump manual.



# Troubleshooting Chart

## WARNING

To reduce the risk of serious injury whenever you are instructed to relieve pressure, always follow the **Pressure Relief Procedure** on page 6.

1. **Relieve the pressure.**
2. Check all possible causes and problems before disassembling the pump.

PROBLEM	CAUSE	SOLUTION
Ram will not raise or lower.	Closed air valve or clogged air line.	Clear the air line; increase the air supply. Check that the valves are open.
	Not enough air pressure to ram.	Increase the air pressure, but do not exceed 150 psi (1.0 MPa, 10 bar).
	Worn or damaged piston.	Service. See page 10.
	Ram director valve is closed or clogged.	Open the valve; clear.
Ram raises and lowers too fast.	Air pressure to ram is too high.	Decrease the air pressure.
Fluid squeezes past the ram plate.	Air pressure to ram is too high.	Decrease the air pressure.
	Wiper pressure is too low.	Adjust pressure. <b>Do not exceed 25 psi (0.18 MPa, 1.8 bar) to avoid wiper overpressurization and rupture.</b>
	Worn or damaged wiper.	Replace.
Pump will not prime properly or pumps air.	Closed air valve or clogged air line.	Clear the air line; increase the air supply. Check that the valves are open.
	Not enough air pressure to ram.	Increase the air pressure, but do not exceed 100 psi (0.7 MPa, 7 bar).
	Worn or damaged piston.	Service. See page 10.
	Ram director valve is closed or clogged.	Open the valve; clear.
	Ram director valve is dirty, worn, or damaged.	Clean; service.
Air director valve will not hold drum down or lift plate up.	Closed air valve or clogged air line.	Clear the air line; increase the air supply. Check that the valves are open.
	Not enough air pressure to ram.	Increase the air pressure, but do not exceed 100 psi (0.7 MPa, 7 bar).
	Valve passage clogged.	Clean.

# Service

## Piston Rod Packing Service

### **WARNING**

To reduce the risk of serious injury whenever you are instructed to relieve pressure, always follow the **Pressure Relief Procedure** on page 6.

1. If air leaks around the piston rod packing nut (9), tighten the nut. If the air leak continues, **relieve the pressure** and continue as follows.
2. Remove the four nuts (4) and lockwashers (5) holding the support beam (3) to the rod (8), and remove the support beam. Screw the packing nut (9) out of the housing (16) and slide it up off the rod (8). See Fig. 3.
3. Remove the bearing (10), female gland (11), packings (12), male gland (13) and spring (14) and slide them up off the rod (8).
4. Inspect the parts for wear or damage. Replace as necessary.
5. Slide the spring (14) and male gland (13) onto the rod (8). Lubricate the packings (12) and slide them onto the rod one at a time, with the lips facing down. Slide the female gland (11) onto the rod and push all of the packings into the housing (16). Slide the bearing (10) onto the rod.
6. Slide the packing nut (9) onto the rod (8) and screw it into the housing (16). Tighten just snug; do not overtighten or the packings may be damaged.
7. Reinstall the support beam (3) on the rods (8), using the nuts (4) and lockwashers (5).



## Ram Piston Service

### **WARNING**

To reduce the risk of serious injury whenever you are instructed to relieve pressure, always follow the **Pressure Relief Procedure** on page 6.

1. **Relieve the pressure.**
2. Remove the support beam (3) as explained under **Piston Rod Packing Service**.
3. Remove the cylinder cap (7) and slide it up off the piston rod (8). Loosen the packing nut (9) and carefully slide the packing nut, bearing (10), and housing assembly (16) up off the rod. See Fig. 3.
4. Carefully pull the piston rod (8) **straight** up out of the cylinder (1). If the rod is cocked to one side, the piston or inside surface of the cylinder could be damaged.
5. Carefully lay the piston and rod down so the rod will not be bent. Remove the piston retainer nut (25), washer (5), piston (22), outer piston seal (15), inner piston seal (23) and spring (18).
6. Install the piston seals (23 and 15) on the piston (22) and lubricate the piston and seals. Reinstall the spring (18), piston (22), washer (5) and nut (25) on the piston rod (8).
7. Carefully insert the piston into the cylinder (1) and push the rod (8) **straight** down into the cylinder. Align the pin in the housing (16) with the slot in the cylinder, and slide the housing, bearing (10), and packing nut (9) down onto the piston rod (8). Tighten the packing nut just snug; do not overtighten or the packings may be damaged.
8. Reinstall the cylinder cap (7) and beam (3).

# Service

-  Lubricate.
-  Lips of v-packings must face down.

## Packing Detail

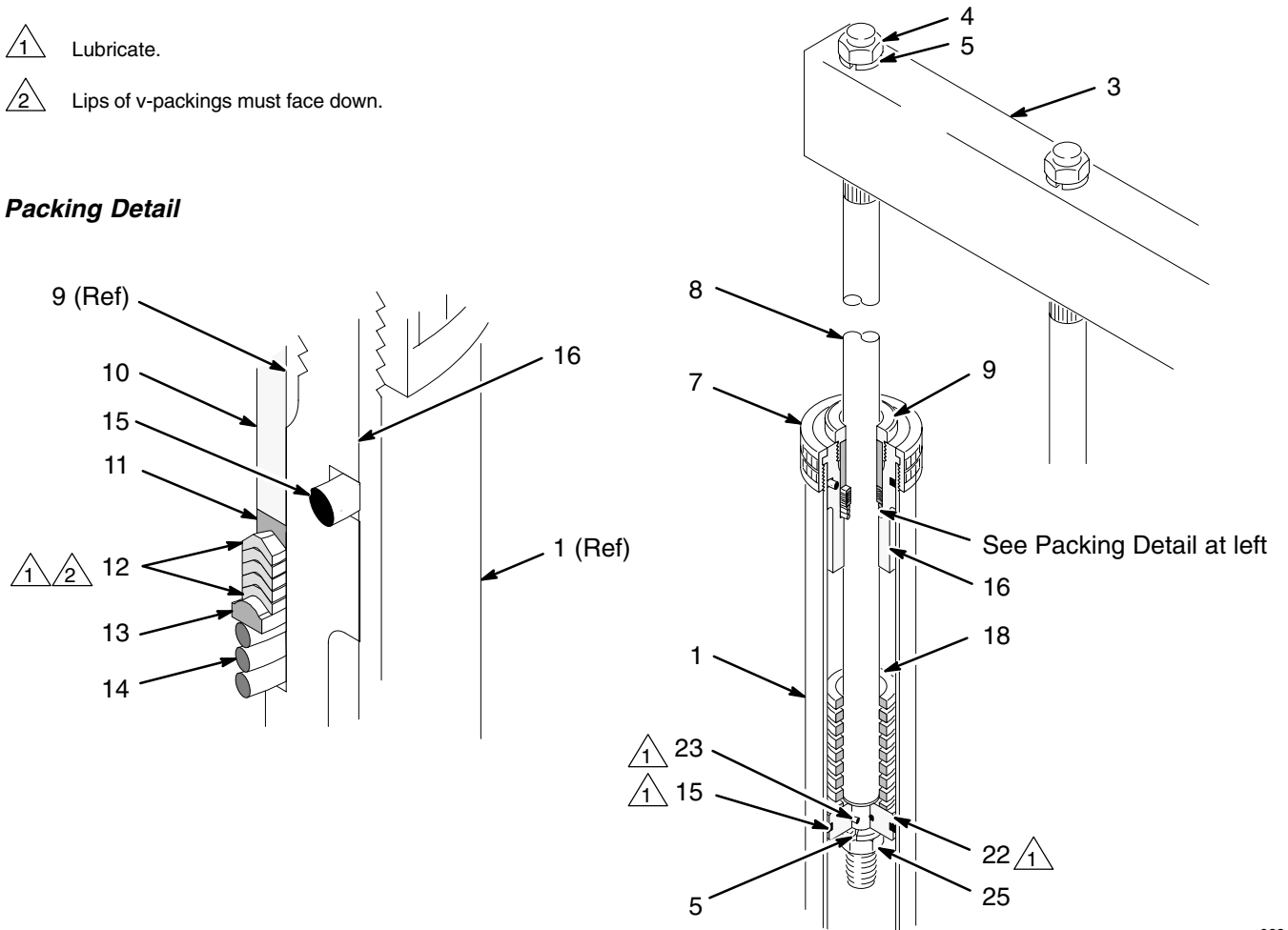

Fig. 3

02944

# Parts

Part No. 234015, Series B

Part No. 24B921, Series A

Part No. 954285, Series A

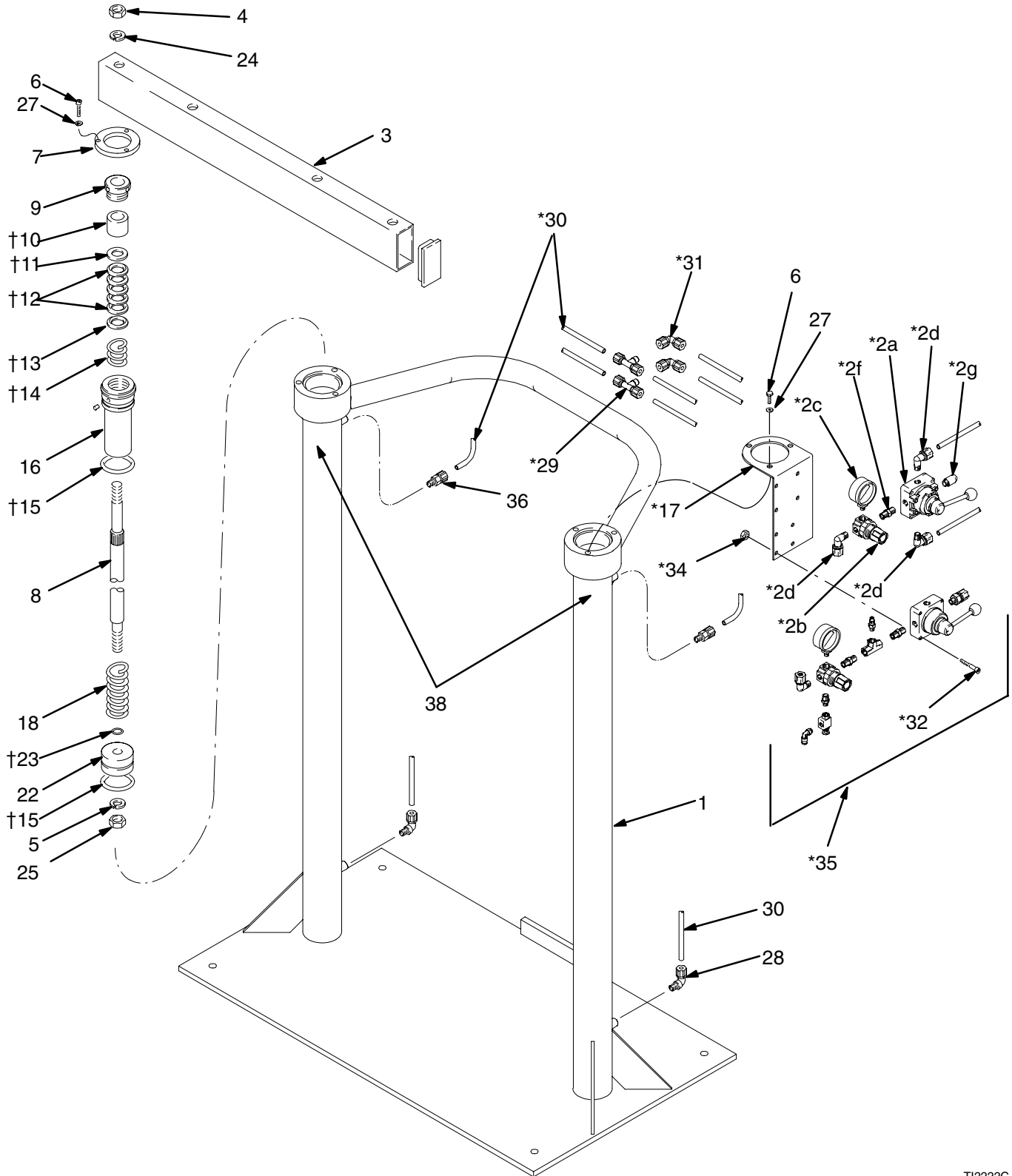

# Parts

## Part No. 234015, Series B

## Part No. 24B921, Series A

## Part No. 954285, Series A

Ref. No.	Part No.	Description	Qty.	Ref. No.	Part No.	Description	Qty.
1	947125	RAM BASE & AIR CYLINDER	1	17*		BRACKET, air kit	1
2*		AIR CONTROL VALVE ASSY			117643	For Model 234015	
		Includes items 2a–2h	1		624826	For Model 954285	
	234030	For Model 234015		18	160138	SPRING, helical compression	2
	948574	For Model 954285		22	625766	PISTON, ram	2
2a*	C06015	. VALVE, 4 way control; 1/4 npt	1	23†	156401	SEAL, o-ring; nitrile rubber	2
2b*	512896	. REGULATOR, air	1	24	512743	WASHER, flat; sst	2
2c*	513199	. GAUGE, air pressure	1	25	101535	NUT, hex; 7/8"	2
2d*	608780	. ELBOW	3	26	624825	STOP, ram	2
2e*	512910	. MUFFLER; 1/4 npt(m)	1	27	103975	WASHER, lock	6
2f*	166421	. NIPPLE; 1/4 npt	1	28	113521	ELBOW	2
2g*	608789	. CONNECTOR, tube	1	29*	513197	TEE	2
2h*	513066	. TUBE; nylon; 3/8 in. (10 mm) OD; 12 ft (3.7 m)	1	30*	513066	TUBE; nylon; 3/8 in. (10 mm) OD	25 ft (7.6 m)
3	620426	BEAM, support	1	31*	513198	ELBOW	2
4	510221	NUT, hex	2	32*		SCREW, cap; socket hd; sst	4
5	164362	WASHER, flat; 3/4"	2		15B588	For Model 234015	
6	102471	SCREW, cap, hex hd	6		500171	For Model 954285	
7	622566	CAP, cylinder	2	34*		NUT, hex; sst	4
8	167651	ROD, ram piston	2		109478	For Model 234015	
9	620424	NUT, packing	2		104121	For Model 954285	
10†	160093	BEARING, piston rod; aluminum	2	35*	15B154	KIT, control, inflatable seal; Model 234015 only	1
11†	157636	GLAND, female packing	2				
12†	159314	V-PACKING, pre-formed	10	36	608789	CONNECTOR, tube	2
13†	157638	GLAND, male packing	2	38▲	C14043	LABEL, warning	4
14†	158388	SPRING, helical compression	2				
15†	160258	SEAL, o-ring; nitrile rubber	4				
16	623959	HOUSING, nut, packing	2				

▲ Replacement Warning labels, tags and cards are available at no cost.

\* These parts are not included in Model 24B921.

† These parts are included in Repair Kit 948143, which may be purchased separately.

# Dimensions

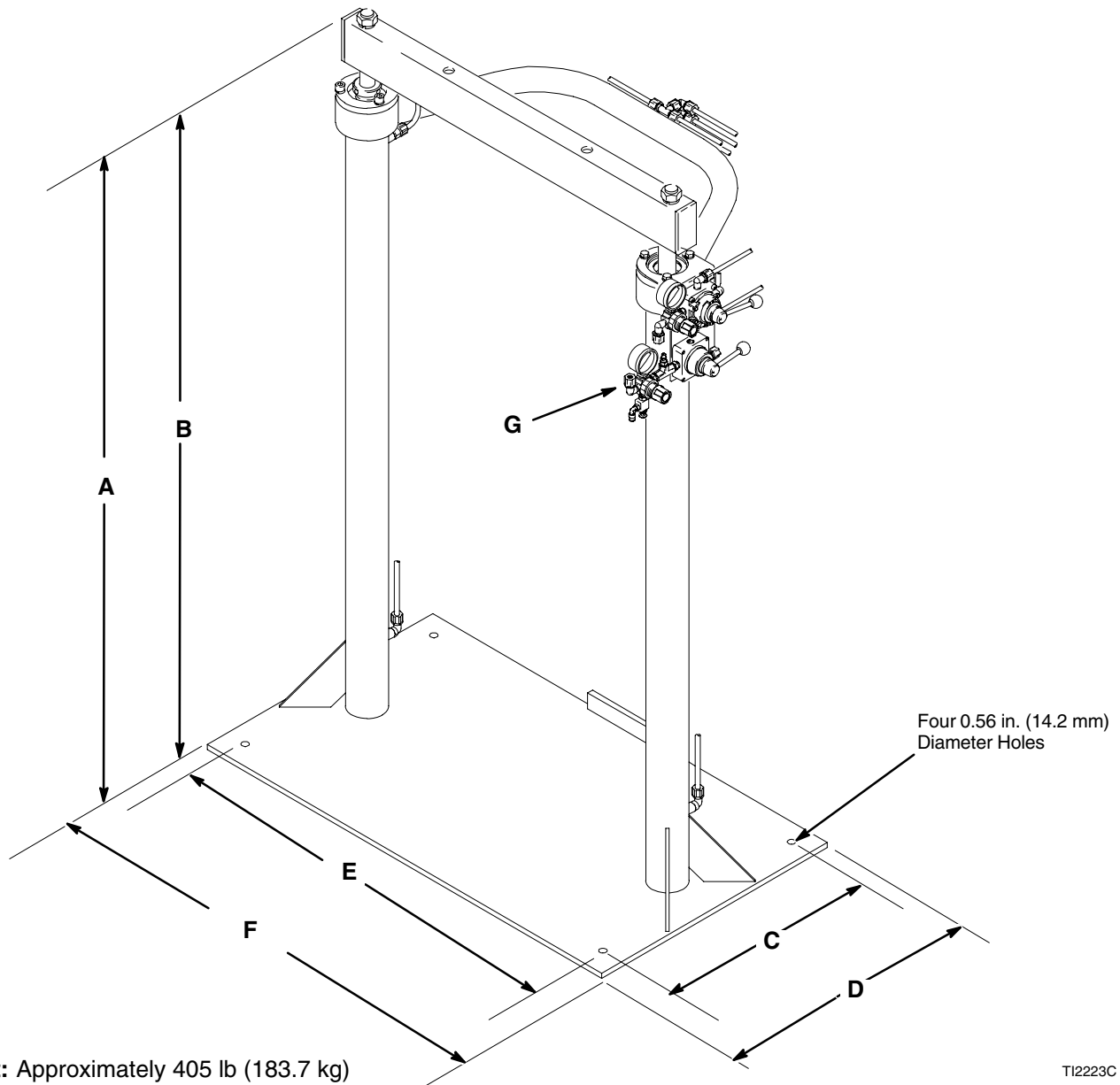

**Weight:** Approximately 405 lb (183.7 kg)

T12223C

<b>A</b> <b>(raised)</b>	<b>B</b> <b>(lowered)</b>	<b>C</b>	<b>D</b>	<b>E</b>	<b>F</b>	<b>G</b> <b>(air inlet)</b>
107 in. (2718 mm)	67 in. (1702 mm)	20 in. (508 mm)	24 in. (610 mm)	38 in. (965 mm)	42 in. (1067 mm)	1/4 npsm(f)

# Technical Data

Maximum air inlet pressure . . 100 psi (0.7 MPa, 7 bar)

Wetted parts . . . . . cast aluminum, ethylene-propylene



# Graco Standard Warranty

Graco warrants all equipment manufactured by Graco and bearing its name to be free from defects in material and workmanship on the date of sale by an authorized Graco distributor to the original purchaser for use. With the exception of any special, extended, or limited warranty published by Graco, Graco will, for a period of twelve months from the date of sale, repair or replace any part of the equipment determined by Graco to be defective. This warranty applies only when the equipment is installed, operated and maintained in accordance with Graco's written recommendations.

This warranty does not cover, and Graco shall not be liable for general wear and tear, or any malfunction, damage or wear caused by faulty installation, misapplication, abrasion, corrosion, inadequate or improper maintenance, negligence, accident, tampering, or substitution of non-Graco component parts. Nor shall Graco be liable for malfunction, damage or wear caused by the incompatibility of Graco equipment with structures, accessories, equipment or materials not supplied by Graco, or the improper design, manufacture, installation, operation or maintenance of structures, accessories, equipment or materials not supplied by Graco.

This warranty is conditioned upon the prepaid return of the equipment claimed to be defective to an authorized Graco distributor for verification of the claimed defect. If the claimed defect is verified, Graco will repair or replace free of charge any defective parts. The equipment will be returned to the original purchaser transportation prepaid. If inspection of the equipment does not disclose any defect in material or workmanship, repairs will be made at a reasonable charge, which charges may include the costs of parts, labor, and transportation.

**THIS WARRANTY IS EXCLUSIVE, AND IS IN LIEU OF ANY OTHER WARRANTIES, EXPRESS OR IMPLIED, INCLUDING BUT NOT LIMITED TO WARRANTY OF MERCHANTABILITY OR WARRANTY OF FITNESS FOR A PARTICULAR PURPOSE.**

Graco's sole obligation and buyer's sole remedy for any breach of warranty shall be as set forth above. The buyer agrees that no other remedy (including, but not limited to, incidental or consequential damages for lost profits, lost sales, injury to person or property, or any other incidental or consequential loss) shall be available. Any action for breach of warranty must be brought within two (2) years of the date of sale.

Graco makes no warranty, and disclaims all implied warranties of merchantability and fitness for a particular purpose in connection with accessories, equipment, materials or components sold but not manufactured by Graco. These items sold, but not manufactured by Graco (such as electric motors, switches, hose, etc.), are subject to the warranty, if any, of their manufacturer. Graco will provide purchaser with reasonable assistance in making any claim for breach of these warranties.

In no event will Graco be liable for indirect, incidental, special or consequential damages resulting from Graco supplying equipment hereunder, or the furnishing, performance, or use of any products or other goods sold hereto, whether due to a breach of contract, breach of warranty, the negligence of Graco, or otherwise.

## **FOR GRACO CANADA CUSTOMERS**

The parties acknowledge that they have required that the present document, as well as all documents, notices and legal proceedings entered into, given or instituted pursuant hereto or relating directly or indirectly hereto, be drawn up in English. Les parties reconnaissent avoir convenu que la rédaction du présente document sera en Anglais, ainsi que tous documents, avis et procédures judiciaires exécutés, donnés ou intentés à la suite de ou en rapport, directement ou indirectement, avec les procédures concernées.

# Graco Information

For the latest information about Graco products, visit [www.graco.com](http://www.graco.com).

**TO PLACE AN ORDER**, contact your Graco distributor, or call one of the following numbers to identify the distributor closest to you:

**1-800-367-4023 Toll-Free**

**612-623-6921**

**612-378-3505 Fax**

*All written and visual data contained in this document reflect the latest product information available at the time of publication.*

*Graco reserves the right to make changes at any time without notice.*

Original instructions. This manual contains English. MM 310572

**Graco Headquarters:** Minneapolis

**International Offices:** Belgium, China, Japan, Korea

**GRACO INC. P.O. BOX 1441 MINNEAPOLIS, MN 55440-1441**

Copyright 2002, Graco Inc. is registered to ISO 9001

**[www.graco.com](http://www.graco.com)**

Revised 07/2010