

Ultra Max II 695/795/1095™

309951E

3300 psi (228 bar, 22.8 MPa) Maximum Working Pressure

220 – 240 VAC Europe

Ultra Max II	Series	Lo-boy	Hi-boy
695	A	248042	248041
795	A		248043
1095	A		248044

220 – 240 VAC Europe Multi-cord

Ultra Max II	Series	Lo-boy	Hi-boy
695	A	248046	248045
795	A		248047
1095	A		248048

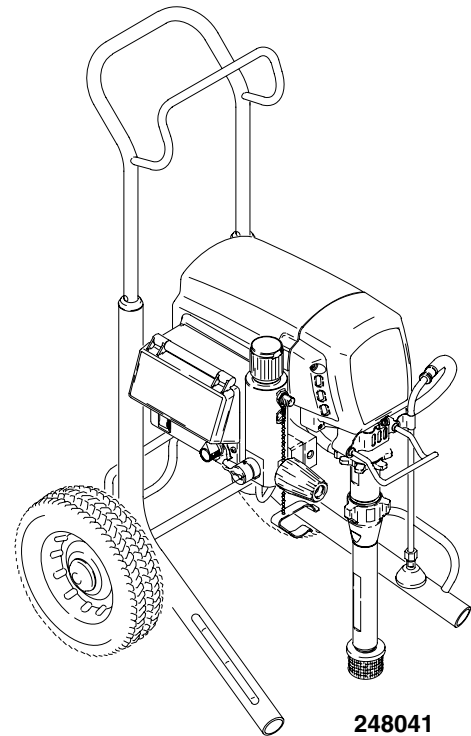

Related manuals

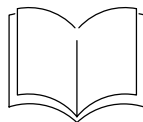

..... 311286



..... 309639



..... 309941



..... 310643



..... 309640

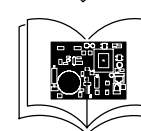

..... 310657

PROVEN QUALITY. LEADING TECHNOLOGY.

Parts Drawing - Sprayer

Model
248042
248046

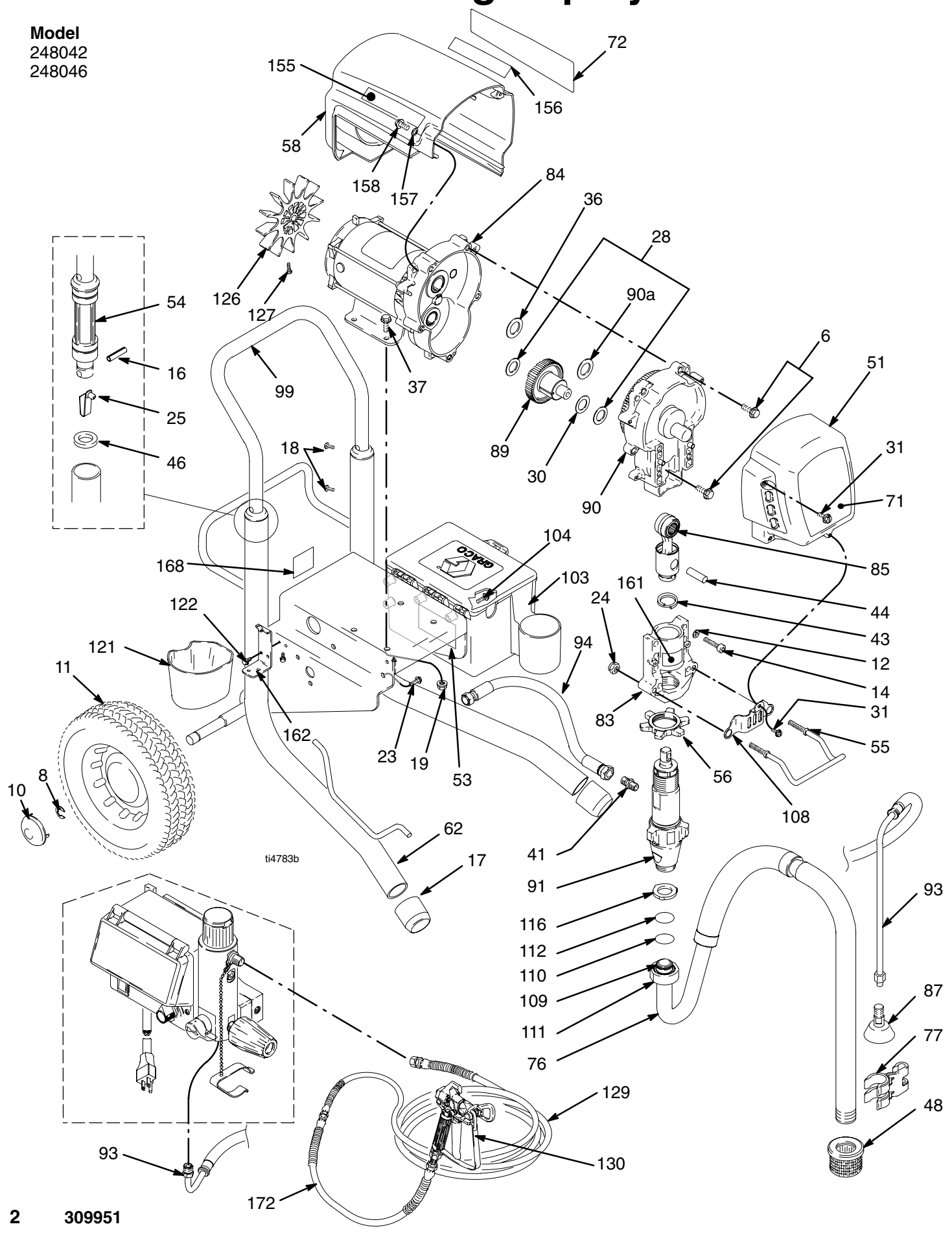

Parts List - Sprayer

Ultra Max 695: 248042, B; 248046, B

Ref No.	Part No.	Description	Qty	Ref No.	Part No.	Description	Qty
6	15C753	SCREW, mach, torx, hex wash hd	5	79	206994	FLUID, TSL, 8 oz (not shown)	1
8	101242	RING, retaining, ext	2	83	240523	HOUSING, bearing, includes 24, 55	1
10	104811	CAP, hub	2	84	287241	MOTOR, electric; includes 126, 127	1
11	106062	WHEEL, semi pneumatic	2	85	241008	ROD, connecting; includes 43	1
12	106115	WASHER, lock spring (hi-collar)	4	87	241920	DEFLECTOR, threaded	1
14	110141	SCREW, cap, socket hd	4	89	287289	GEAR, combination; includes 28, 30	1
16	101354	PIN, spring	2	90	287283	HOUSING, drive; includes 6, 36, 90a	1
17	15C871	CAP, leg	2	90a	107089	WASHER, thrust	1
18	109032	SCREW, mach, pnh	4	91	248204	PUMP, displacement; includes 109 Manual, 310643	1
19	110996	NUT, hex, flanged	4				
23	110963	SCREW, cap, flng hd	2	93	248217	HOSE, drain; includes 87	1
24	112746	NUT, hex	2	94	15D049	HOSE	1
25	112827	BUTTON, snap	2	99	15G023	HANDLE, cart	1
28	114672	WASHER, thrust	2	103	287253	TOOL BOX; includes 104	1
30	114699	WASHER, thrust	1	104	118852	SCREW, hex washer hd	3
31	118444	SCREW, machine hex washer head	1	108	15C859	SHIELD, pump rod	1
36	116191	WASHER, thrust	1	109	117559	O-RING	2
37	100057	SCREW, hex hd	4	110	15C981	WASHER, suction swivel	1
41	162453	NIPPLE, (1/4 npsm x 1/4 npt)	1	111	15C980	NUT, jam	1
43	176817	SPRING, retaining	1	112	118505	RING, retaining, external	1
44	176818	PIN, str, hdls	1	116	115099	WASHER, garden hose	1
46	183350	WASHER	2	121	276975	CUP, drain	1
48	189920	STRAINER, (1-11 1/2 npsm)	1	122	114423	SCREW, hex hd	2
51	287291	COVER, drive, painted; includes 31, 157, 158	1	126	15D088	FAN, motor	1
54	192027	SLEEVE, cart	2	127	115477	SCREW, mach., torx pan hd	1
55	15D416	HANGER, pail	1	128▲	222385	TAG, WARNING, (not shown)	1
56	192723	NUT, retaining	1	129	240794	HOSE, cpld, 1/4 x 50 ft, unpkgd	1
58	287281	SHIELD, motor, painted; includes 157, 158	1	130	246222	GUN, Contractor II-E Manual 309639	1
62	287168	FRAME, cart, Lo-boy	1	157	276980	GROMMET	2
71	15D065	LABEL, front	1	158	119250	SCREW, shoulder	2
72	15D066	LABEL, side	1	161	187436	LABEL, torque	1
76	248216	HOSE, suction; includes 109, 110, 111, 112, 116	1	162	15F952	BRACKET, suction	1
77	15D000	CLIP, drain line	1	168	195767	LABEL, danger	1
				172	238358	HOSE, cpld, 3/16 in. x 3 ft	1

▲ Extra Danger and Warning tags and labels available free.

Parts List - Sprayer

Ultra Max 695: 248041, B; 248045, B

Ultra Max 795: 248043, B; 248047, B

Ref .	Part No.	Description	Qty	Ref	Part No.	Description	Qty
6	15C753	SCREW, mach, torx, hex wash hd	5	76	248214	TUBE, intake; includes 109	1
8	101242	RING, retaining, ext.	2	77	197124	CLIP, spring	1
10	104811	CAP, hub	2	79	206994	FLUID, TSL, 8 oz (not shown)	1
11	106062	WHEEL, semi pneumatic	2	83	240523	HOUSING, bearing; includes 24, 55	1
12	106115	WASHER, lock spring (hi-collar)	4	84		MOTOR, electric; includes 126, 127	
14	110141	SCREW, cap, socket hd	4		287241	695	1
16	101354	PIN, spring straight	2		287242	795	1
17	15C871	CAP, leg	2	85	241008	ROD, connecting; includes 43	1
18	109032	SCREW, mach, pnh	4	87	241920	DEFLECTOR, threaded	1
19	110996	NUT, hex, flanged	4	89	287289	GEAR, combination; includes 28, 30	1
23	110963	SCREW, cap, flng hd	2	90		HOUSING, drive; includes 6, 36, 90a	
24	112746	NUT, hex	2		287283	695	1
25	112827	BUTTON, snap	2		287284	795	1
28	114672	WASHER, thrust	2	90a	107089	WASHER, thrust	1
30	114699	WASHER, thrust	1	91	248204	PUMP, displacement	1
31	118444	SCREW, mach hex washer head	5			Manual 310643	
36	116191	WASHER, thrust	1	93	248217	HOSE, coupled; includes 87	1
37	100057	SCREW, hex hd	4	94	15D049	HOSE	1
41	162453	NIPPLE, (1/4 npsm x 1/4 npt)	1	99	245245	HANDLE, cart	1
43	176817	SPRING, retaining	1	103	287253	TOOL BOX; includes 104	1
44	176818	PIN, str, hdls	1	104	118852	SCREW, hex washer hd	3
46	183350	WASHER	2	105	15D281	HANGER, stand, cart	1
48	189920	STRAINER, (1-11 1/2 npsm)	1	106	15C982	CAM, cart	2
51	287291	COVER, drive, painted	1	107	114531	SCREW, flange, hex	4
		includes 31, 157, 158		108	15C859	SHIELD, pump rod	1
54	192027	SLEEVE, cart	2	109	118494	O-RING	1
55	192719	HANGER, pail	1	126	15D088	FAN, motor	1
56	192723	NUT, retaining	1	127	115477	SCREW, mach, torx pan hd	1
58		SHIELD, motor, painted;		128▲	222385	TAG, WARNING (not shown)	1
		includes 157, 158		129	240794	HOSE, cpld, 1/4 in. x 50 ft	1
	287281	695	1	130	246222	GUN, Contractor II-E	1
	287282	795	1			Manual 309639	
62	287165	FRAME, cart	1	157	276980	GROMMET	2
71		LABEL, front		158	119250	SCREW, shoulder	2
	15D065	695	1	161	187436	LABEL, torque	1
	15D068	795	1	168	195767	LABEL, danger	1
72		LABEL, side		172	238358	HOSE, cpld, 3/16 in. x 3 ft	1
	15D066	695	1	▲		<i>Extra Danger and Warning tags and labels available free.</i>	
	15D069	795	1				

Models
248044
248048

Parts Drawing - Sprayer

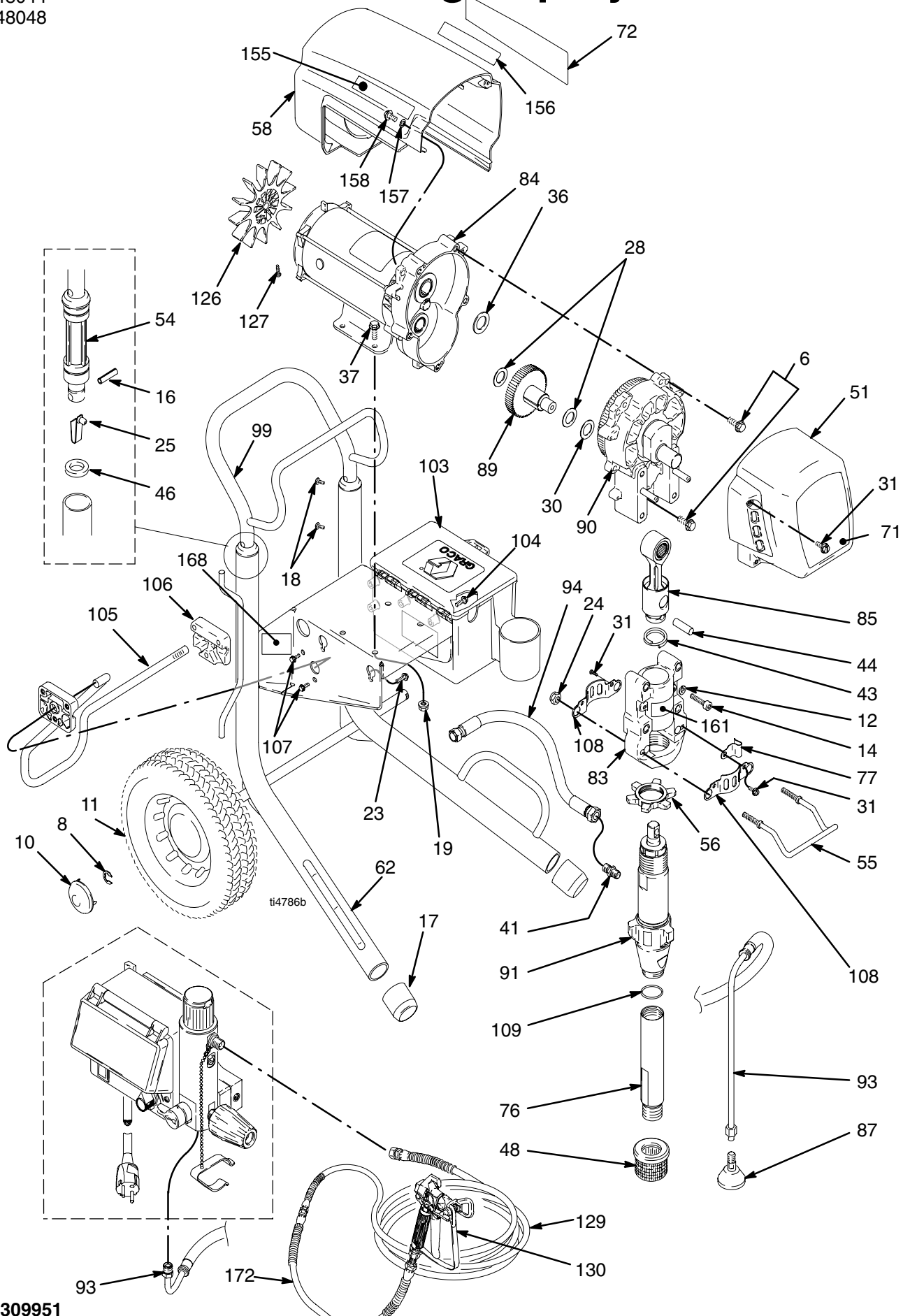

Parts List - Sprayer

Ultra Max 1095: 248044, B; 248048, B

Ref .	Part No.	Description	Qty	Ref	Part No.	Description	Qty
6	15C753	SCREW, mach, torx, hex wash hd	5	76	248215	TUBE, intake; includes 109	1
8	101242	RING, retaining, ext.	2	77	197124	CLIP, spring	1
10	104811	CAP, hub	2	79	206994	FLUID, TSL, 8 oz (not shown)	1
11	179811	WHEEL, semi pneumatic	2	83	241015	HOUSING, bearing; includes 24, 55	1
12	106115	WASHER, lock spring (hi-collar)	4	84	287243	MOTOR, electric; includes 126, 127	1
14	114666	SCREW, cap, socket hd	4	85	241279	ROD, connecting; includes 43	1
16	108068	PIN, spring straight	2	87	241920	DEFLECTOR, threaded	1
17	276974	CAP, leg	2	89	287290	GEAR, combination; includes 28, 30	1
18	108795	SCREW, mach, pnh	4	90	287295	HOUSING, drive; includes 6, 36	1
19	110996	NUT, hex, flanged	4	91	248205	PUMP, displacement	1
23	110963	SCREW, cap, flng hd	2			Manual 310643	
24	112746	NUT, hex	2	93	248217	HOSE, coupled; includes 87	1
25	112827	BUTTON, snap	2	94	15D360	HOSE	1
28	114672	WASHER, thrust	2	99	245245	HANDLE, cart	1
30	114699	WASHER, thrust	1	103	287253	TOOL BOX; includes 104	1
31	118444	SCREW, mach hex washer head	5	104	118852	SCREW, hex washer hd	3
36	116192	WASHER, thrust	1	105	15C858	HANGER, stand, cart	1
37	100057	SCREW, hex hd	4	106	15C982	CAM, cart	2
41	162485	NIPPLE, (3/8 npsm x 3/8 npt)	1	107	114531	SCREW, flange, hex	4
43	183169	SPRING, retaining	1	108	15C762	SHIELD, pump rod	2
44	183210	PIN, str, hdls	1	109	118494	O-RING	1
46	183350	WASHER	2	126	15D088	FAN, motor	1
48	189920	STRAINER, (1-11 1/2 npsm)	1	127	115477	SCREW, mach, torx pan hd	1
51	287292	COVER, drive, painted	1	128▲	222385	TAG, WARNING (not shown)	1
		includes 157, 158		129	240794	HOSE, cpld, 1/4 in. x 50 ft	1
54	191084	SLEEVE, cart	2	130	246222	GUN, Contractor II-E	1
55	192719	HANGER, paiL	1			Manual 309639	
56	193031	NUT, retaining	1	157	276980	GROMMET	2
58	287282	SHIELD, motor, painted;	1	158	119250	SCREW, shoulder	2
		includes 157, 158		161	187437	LABEL, torque	1
62	287207	FRAME, cart	1	168	195767	LABEL, danger	1
71	15D071	LABEL, front	1	172	238358	HOSE, cpld, 3/16 in. x 3 ft	1
72	15D072	LABEL, side	1				

▲ Extra Danger and Warning tags and labels available free.

Parts Drawing - Sprayer

Models

- 248041
- 248042
- 248043
- 248044
- 248045
- 248046
- 248047
- 248048

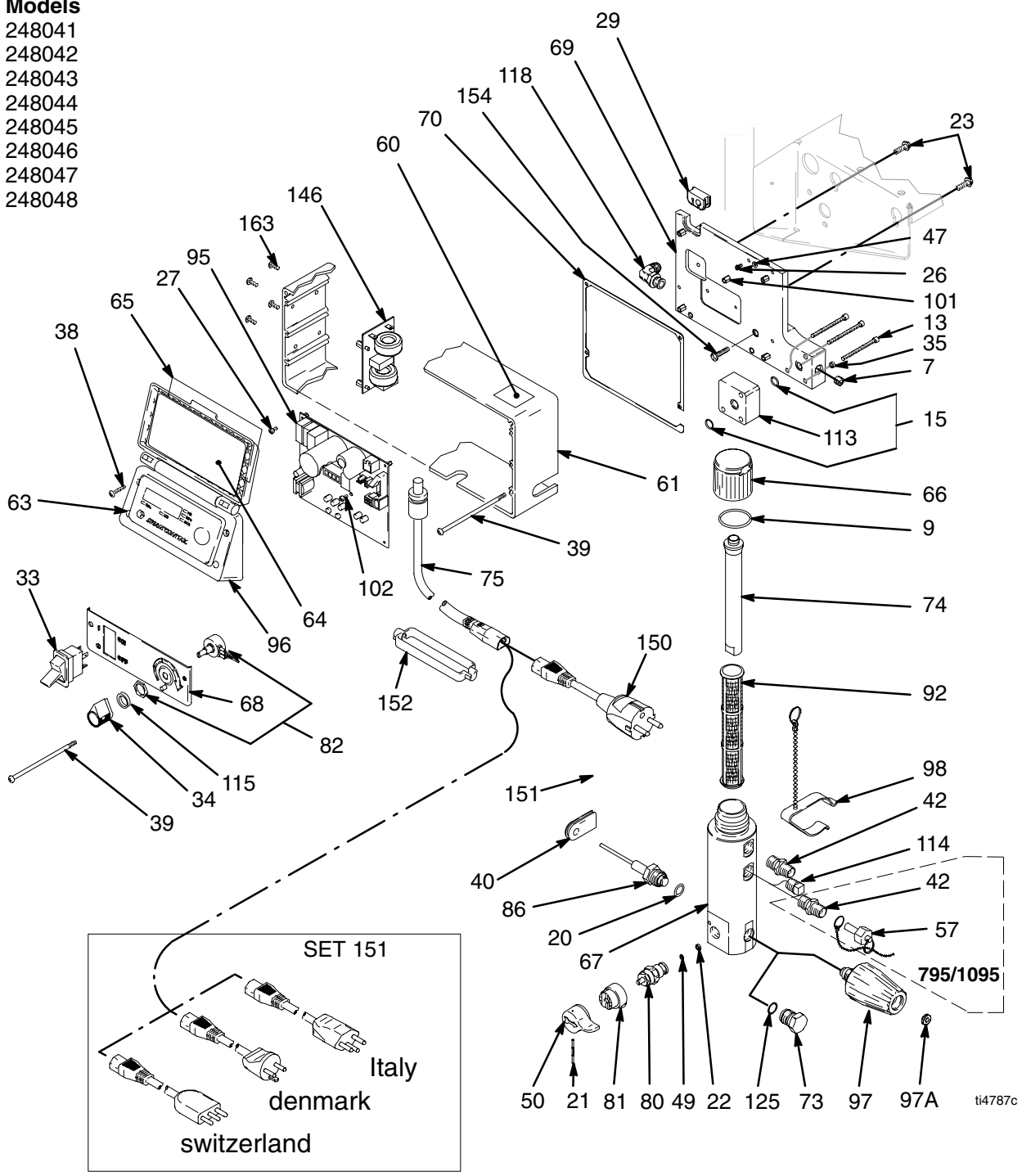

ti4787c

Parts List - Sprayer

Ultra Max II 695/795/1095

REF NO.	PART NO.	DESCRIPTION	QTY	REF NO.	PART NO.	DESCRIPTION	QTY
7	100721	PLUG, pipe	1	74	15C766	TUBE, diffusion	1
9	117285	O-RING	1	75		CORD, power	
13	C19817	SCREW, cap, socket hd	3		15D528	CEE/7	1
15	107505	O-RING	2		15D529	MULTI-CORD	1
20	111457	O-RING	1	80	235014	VALVE, drain; includes 22, 49	1
21	15C972	PIN, grooved	1	81	224807	BASE, valve	1
22	111699	GASKET, seat, valve	1	82	236352	POTENTIOMETR, adj, pressure	1
23	110963	SCREW, cap, flg hd	2	86	243222	TRANSDUCER, press ctrl; includes 20	1
26	114391	SCREW, grounding	1	92		FILTER, fluid	
27	113045	SCREW, sems, mach, phil truss	5		244071	30 mesh	1
29	15D087	GROMMET	1		244067	60 mesh, original equipment	1
33	15D527	SWITCH, rocker	1		244068	100 mesh	1
34	116167	KNOB, potentiometer	1		244069	200 mesh	1
35	105510	WASHER, lock, spring (hi-collar)	3	95	287248	CONTROL, bd, 240V; includes 27, 102	1
38	116252	SCREW, #8 taptite phil	4	96	287286	COVER, control	
39	112381	SCREW, mach, pan hd	4			includes 38, 63, 64, 65	1
40	15D033	GROMMET, transducer	1	97	287293	VALVE, AutoClean; includes 97a	1
42		ADAPTER		97a	15F950	GASKET	1
	164672	695	1	98	244346	KIT, repair, clamp, trigger	1
	164672	795/1095	2	101	15D160	STUD, board	5
47	186620	LABEL, symbol, ground	1	102	114420	SCREW, mach, pnh, sems	3
49	187615	SEAT, valve	1	113	15F844	SPACER, filter, base	1
50	15C780	HANDLE, valve, drain	1	114	104813	PLUG, pipe	1
57	240131	STEM, plug, packless	1	115	15C973	GASKET	1
60▲	195793	LABEL, WARNING	1	118		FITTING, elbow, hydraulic	1
61	15D431	BOX, control	1		116793	695, 795	1
63	198648	LABEL, LCD	1		118896	1095	1
64	15D063	LABEL, instruction	1	125	15D541	GASKET	1
65	196670	LABEL, cover, control box	1	146	248220	FILTER BOARD	1
66	287285	CAP, filter; includes 9, 74	1	150	242001	CORD, power, CEE/7	1
67	15C838	BASE, filter	1	151	287121	CORD, power, Multi-cord	1
68	15C947	PANEL, control	1	152	195551	RETAINER, plug	1
69	15C840	PLATE, power bar	1	154	115478	SCREW, Torx, pan hd	1
70	15D036	GASKET, control box	1	163	119228	SCREW, mach, flat hd	4
73	248314	PLUG, AutoClean, includes 125	1				

Wiring Diagram

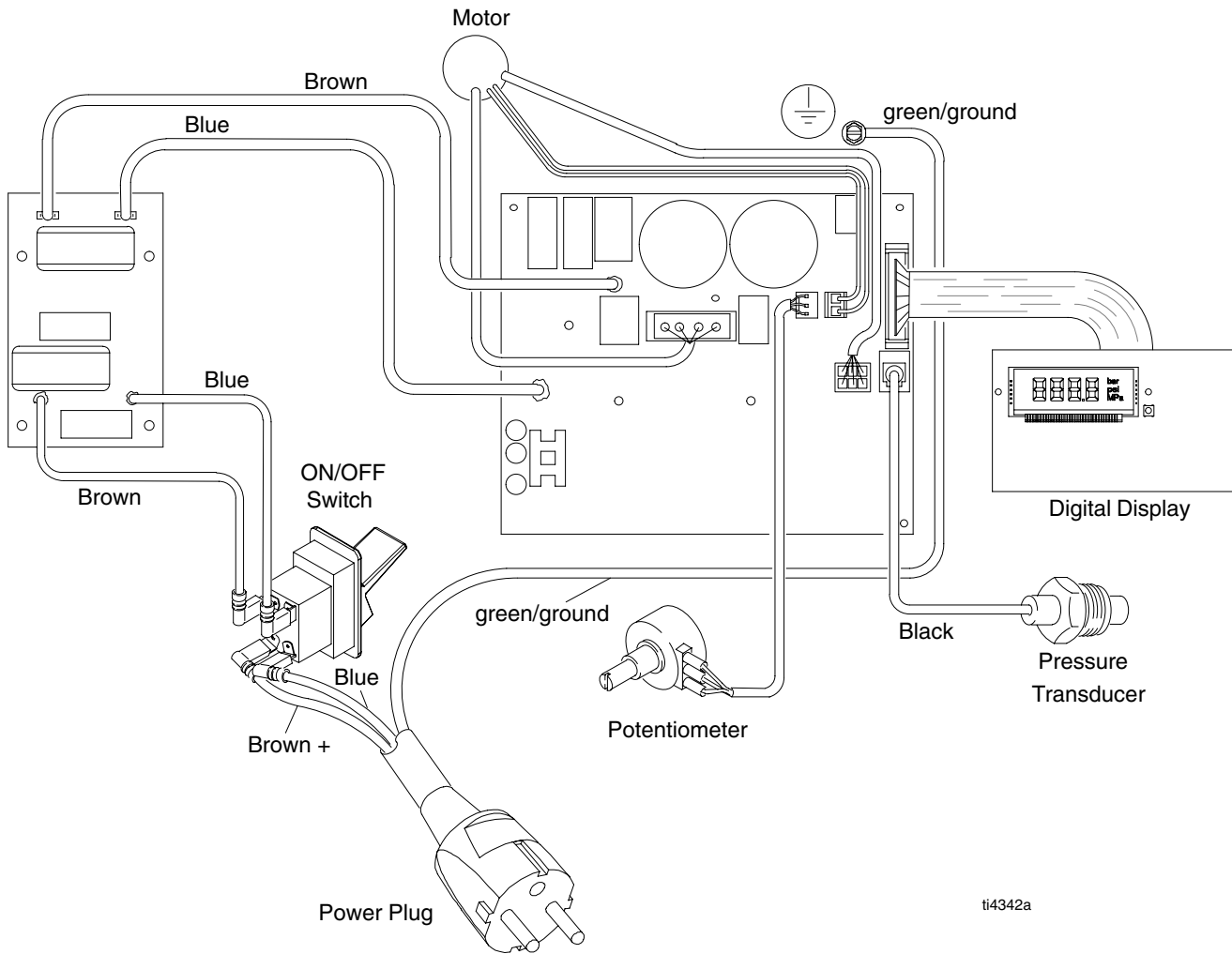

TO PLACE AN ORDER OR FOR SERVICE, contact your Graco distributor, or call this number to identify the distributor near you: **1-800-690-2894 Toll Free**

All written and visual data contained in this document reflects the latest product information available at the time of publication. Graco reserves the right to make changes at any time without notice.

This manual contains: English
mm309951

Graco Headquarters: Minneapolis
International Offices: Belgium, China, Japan, Korea

GRACO INC. P.O. BOX 1441 MINNEAPOLIS, MN 55440-1441

<http://www.graco.com>

PRINTED IN USA 309951 3/2004 Rev 9/2005