

INSTRUCTIONS—PARTS LIST



308336

Rev. J



This manual contains important warnings and information.
READ AND KEEP FOR REFERENCE.

INSTRUCTIONS

First choice when quality counts.™

Series 960

Turbine Spray Guns

50 psi (0.35 MPa, 3.5 bar) Maximum Inlet Fluid Pressure

100 psi (0.7 MPa, 7 bar) Maximum Inlet Air Pressure

CE

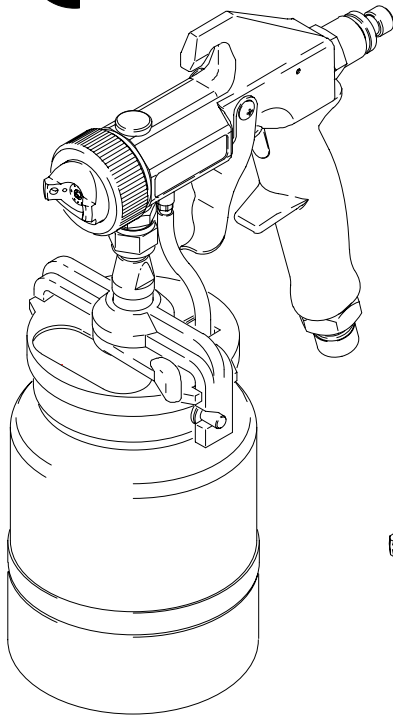

Model 960

Includes 1-quart (1-liter) cup

240080, without fluid set

240083, with #3 fluid set

240084, with #4 fluid set

240085, with #5 fluid set

243920, with 2.0 fluid set

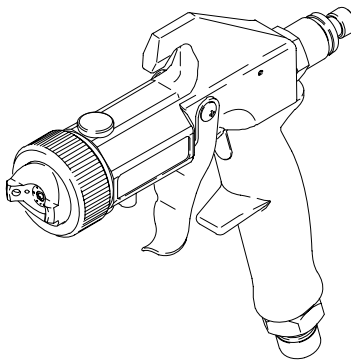

Model 960P

240772, without fluid set

240773, with #3 fluid set

243592, with #1 fluid set

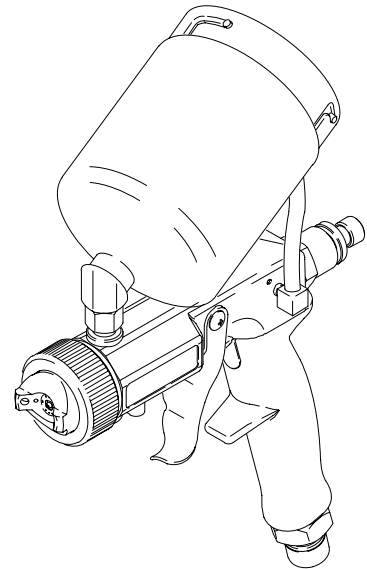

05292A

Model 960GF.5

Includes 1/2-quart (1/2-liter) cup

240530, without fluid set

Model 960GF.75

Includes 3/4-quart (3/4-liter) cup

240532, without fluid set

GRACO INC. P.O. BOX 1441 MINNEAPOLIS, MN 55440-1441

©COPYRIGHT 1993, GRACO INC.

Graco Inc. is registered to I.S. EN ISO 9001

Table of Contents

Warnings	2
Setup	4
Shutdown	12
Spraying Techniques	13
Maintenance	13
Service	16
Troubleshooting	18
Parts	
Model 960	20
Models 960GF.5 & 960GF.75	22
Model 960P	24
Accessories	25
Technical Data	25
Graco Phone Number	26
Warranty	26

Symbols

Warning Symbol



This symbol alerts you to the possibility of serious injury or death if you do not follow the instructions.

Caution Symbol



This symbol alerts you to the possibility of damage to or destruction of equipment if you do not follow the instructions.

WARNING



FIRE AND EXPLOSION HAZARD

Improper grounding, poor ventilation, open flames or sparks can cause a hazardous condition and result in a fire or explosion and serious injury.

- Ground the equipment.
- If there is any static sparking or you feel an electric shock while using this equipment, **stop spraying immediately**. Do not use the equipment until you identify and correct the problem.
- Provide fresh air ventilation to avoid the buildup of flammable fumes from solvents or the fluid being sprayed.
- When flammable liquid is sprayed or used for flushing or cleaning the equipment, the turbine must be placed at least 20 feet (6.1 m) away from areas where hazardous concentrations of flammable vapors are likely to occur.
- Use additional air hose if necessary to ensure that the turbine is operated in a clean, dry, well-ventilated area.
- Never place the turbine inside a spray booth! Use this equipment outdoors or in extremely well-ventilated areas.
- Keep the spray area free of debris, including solvent, rags, and gasoline.
- Electrically disconnect all equipment in the spray area.
- Extinguish all open flames or pilot lights in the spray area.
- Do not smoke in the spray area.
- Do not turn on or off any light switch in the spray area while operating or if fumes are present.
- Do not operate a gasoline engine in the spray area.

WARNING



INSTRUCTIONS

EQUIPMENT MISUSE HAZARD

Equipment misuse can cause the equipment to rupture or malfunction and result in serious injury.

- This equipment is for professional use only.
- Read all instruction manuals, tags, and labels before operating the equipment.
- Use the equipment only for its intended purpose. If you are not sure, call your distributor.
- Do not alter or modify this equipment. Use only genuine Graco parts and accessories.
- Check equipment daily. Repair or replace worn or damaged parts immediately.
- Do not exceed the maximum working pressure of the lowest rated system component. See **Technical Data** on page 25.
- Use fluids and solvents which are compatible with the equipment wetted parts. See **Technical Data** on page 25 for this information.
- Do not use hoses to pull equipment.
- Route hoses away from traffic areas, sharp edges, moving parts, and hot surfaces. Do not expose Graco hoses to temperatures above 82°C (180°F) or below -40°C (-40°F).
- Wear hearing protection when operating this equipment.
- Do not lift pressurized equipment.
- Comply with all applicable local, state, and national fire, electrical, and safety regulations.
- Do not point the gun at anyone or at any part of the body.
- Follow the **Pressure Relief Procedure** on page 12 if the fluid nozzle clogs and before cleaning, checking or servicing the equipment.
- Tighten all fluid connections before operating the equipment.
- Check the hoses, tubes, and couplings daily. Replace worn or damaged parts immediately.



TOXIC FLUID HAZARD

Hazardous fluid or toxic fumes can cause serious injury or death if splashed in the eyes or on the skin, inhaled, or swallowed.

- Know the specific hazards of the fluid you are using.
- Store hazardous fluid in an approved container. Dispose of hazardous fluid according to all local, state and national guidelines.
- Always wear protective eyewear, gloves, clothing and respirator as recommended by the fluid and solvent manufacturer.
- Do not use 1,1,1-trichloroethane, methylene chloride, other halogenated hydrocarbon solvents or fluids containing such solvents in the turbine spray system, which contains aluminum and/or galvanized-coated parts. Such use could result in a serious chemical reaction, with the possibility of explosion, which could cause death, serious injury, and/or substantial property damage.

Setup

Connect Fluid and Air Supply

NOTES:

- The HVLP Cart/Compressor provides the air supply for remote pressure pot.
- The circled letters in Fig. 1 indicate hose line connections.

1. Connect gun air supply hose (A) between turbine air outlet (B) and gun air inlet (C). DO NOT use wrench to tighten connections; hand tighten only. See Fig. 1.

For GTS-4900:

The turbine uses quick connector at outlet (B). A wrench is not required for hose connection.

2. If using a spray gun cup (D):
Connect cup to gun fluid inlet (E).

If using accessory remote pressure pots (F):
Connect fluid supply hose (G) between remote pressure pot fluid outlet (H) and gun fluid inlet (E).

3. Connect pressure pot air hose (J) between pressure pot air regulator inlet (K) and the cart compressor air outlet.

Install Fluid Set

Complete spray guns are available with #1, #2, #3, #4, or #5 fluid sets. To install other fluid sets, perform the following steps. See Fig. 2.

1. Remove air cap retaining ring (29). Discard packaging (not shown). Remove detente plate and spring (25).
2. Remove fluid regulator assembly (20, 21, 22) and spring (23) from back of gun.

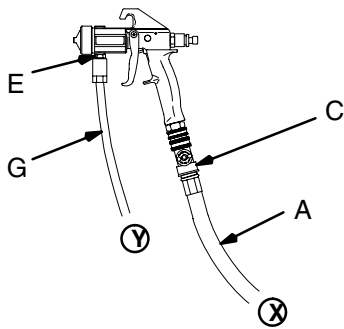

remote pressure pot setup for spray gun

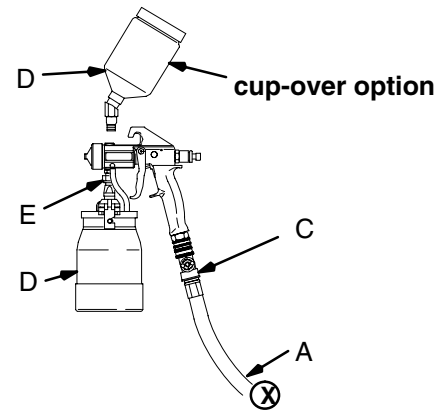

cup setup for spray gun

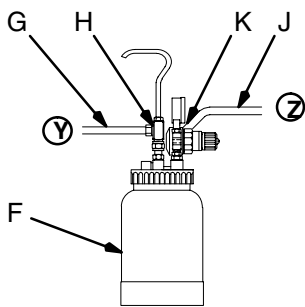

2-quart remote pressure pot

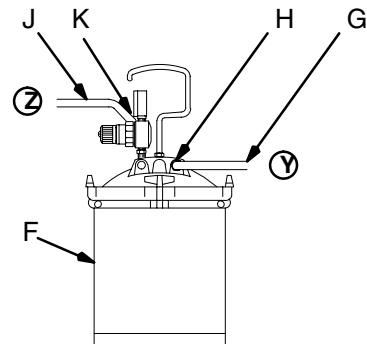
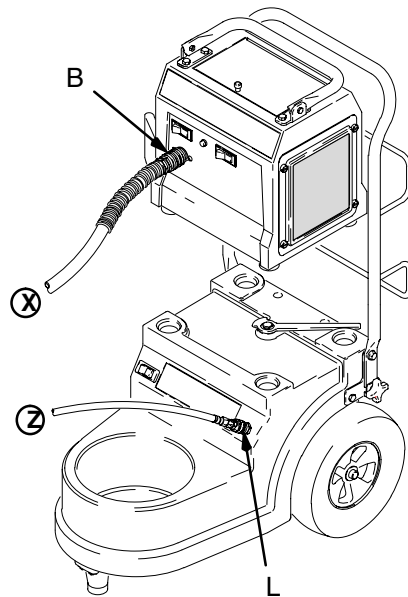

2 1/2-gallon remote pressure pot

Fig. 1

04958B

Setup

3. Fully insert needle assembly (14) into back of fluid manifold (6).
4. Perform needle adjustment procedure steps 2 thru 5 of Adjusting Needle on page 16.
5. Perform needle packings adjustment procedure steps 4 thru 8 of Adjusting Needle Packings on page 16.

Prepare 960 Cup Gun for Pressure Feed

1. Remove air pressure tube (34) from air stem (33). See parts drawing on page 20.
2. Hold fluid inlet fitting (7) with wrench and remove cup assembly (59).
3. Remove air stem (33) from gun body (1).
4. Apply medium strength threadlocker to set screw (61) and assemble to gun body.

Prepare Fluid

1. Always strain fluid before spraying; this includes color, reducer, and hardeners.
2. Use slower drying reducer or thinner to compensate for faster drying time from warm turbine air. Do not over reduce.

Paint Reduction — Automotive Type Finishes

Reduce and catalyze all paint to manufacturer's specifications. Compensate for faster turbine drying time by using reducer one-step slower than conventional air spray.

Paint Reduction — Industrial or Domestic Coatings

Reduce and catalyze all paint to manufacturer's specifications. If no reductions are given, first thoroughly mix fluid to be sprayed. Gradually mix in reducer, testing fluid for correct spraying consistency.

Test consistency, remove stir stick from thinned paint. Consistency is right when first drops from stir stick are about one second apart.

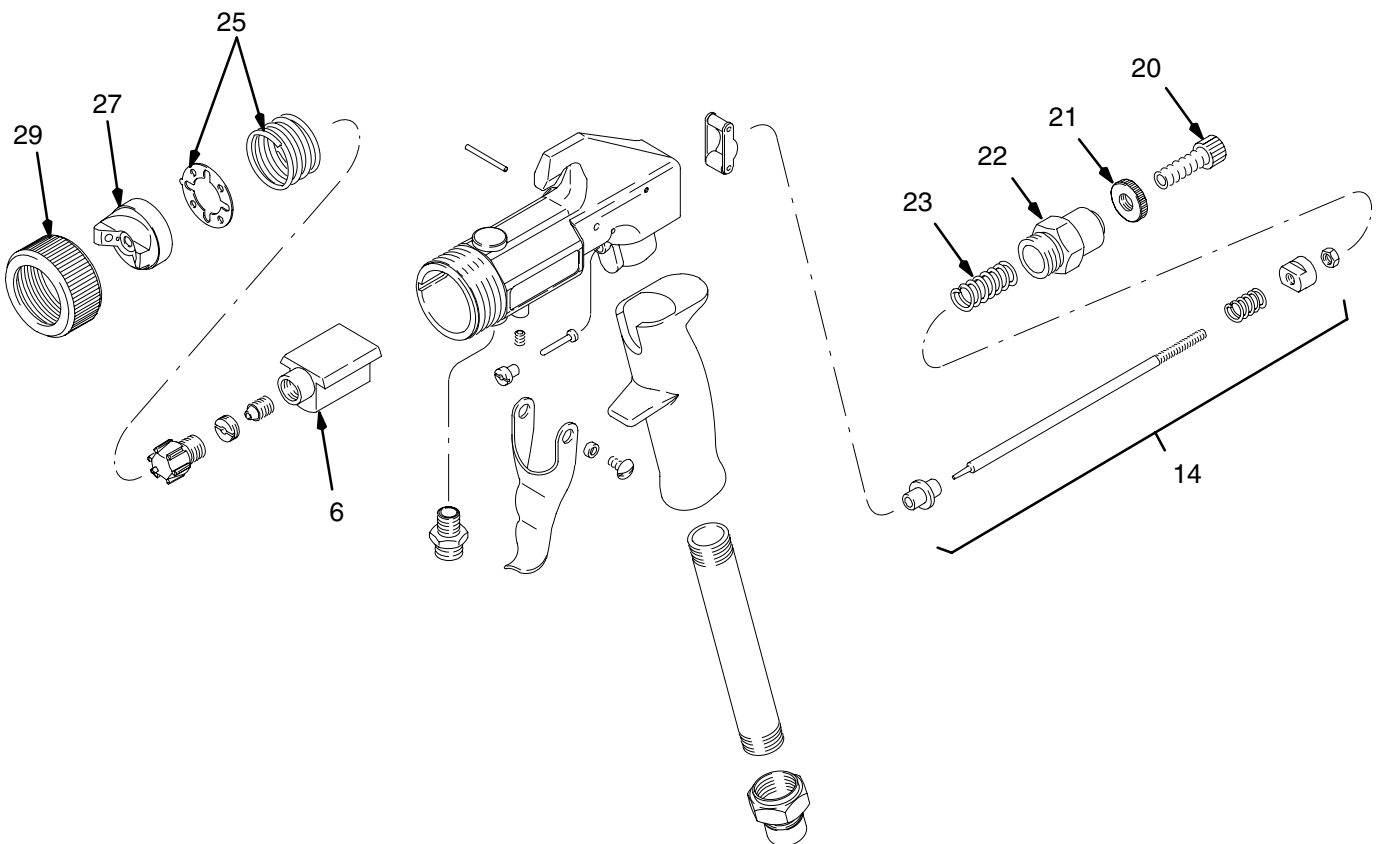

Fig. 2

05289

Setup

Fill Cup or Remote Pressure Pot

Spray Gun Cup

⚠ WARNING

The spray gun cup is pressurized by the gun's air supply. To reduce the risk of serious injury from pressurized fluid or accidental spray from the gun, always turn off the air supply to the gun before removing the spray gun cup.

Fill cup 3/4 full to keep air pressure tube clean. Install cover. Under-cup cover has latch (H) to secure it to cup. Over-cup has ring with notches (J) that secure cup hood when locked in place on cup.

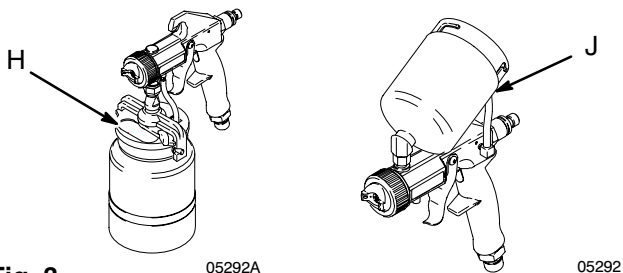

Fig. 3

Accessory Remote Pressure Pot

⚠ WARNING

The accessory remote pressure pots remain pressurized until pressure is manually relieved. To reduce the risk of serious injury from pressurized fluid or accidental spray from the gun, always relieve pressure in the pressure pot before loosening or removing the cover.

1. Relieve remote pot pressure as follows:
 - a. Turn off air supply to pressure pot. See Fig. 4.
 - b. 2¹/₂-gallon remote pressure pot:
Pull pressure relief valve ring (206c) until pressure is completely relieved.
2-quart remote pressure pot:
Turn **out** pressure relief knob (113) one turn.
Wait until pressure is completely relieved before removing cover. Close knob.

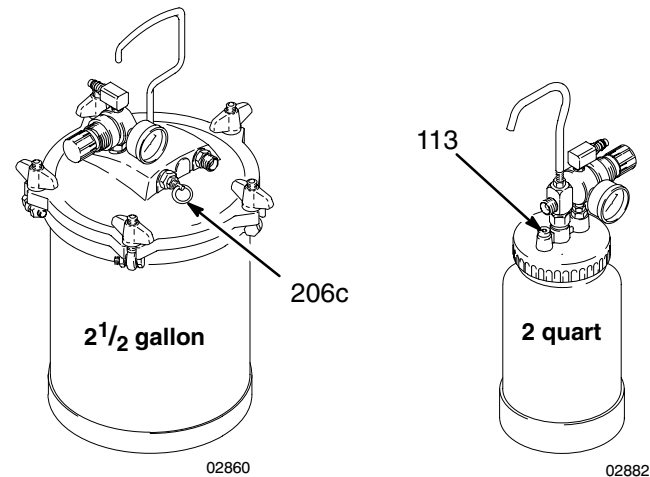

Fig. 4

2. Remove pressure pot cover and fill. Secure cover.

NOTE: 2-quart remote pressure pot only:
Lightly coat cover threads with petroleum jelly.

⚠ CAUTION

If the 2-quart remote pressure pot is accidentally tipped over or held at too great of an angle, fluid may leak into the air regulator and cause damage. Take precautions to avoid this. If fluid does get into the regulator, clean immediately.

⚠ CAUTION

Do not tighten the pressure pot cover more than hand-tight. Excessive tightening may damage the cover gasket.

Setup

Prepare Surface

To achieve proper adhesion, make sure the surface to be sprayed is completely clean.

Turbine Operation

WARNING

Sparking can be expected in the normal operation of the turbine motor. Sparks can ignite fumes from flammable liquid, dust particles, and other flammable substances in the spray area. This can cause serious injury and property damage. Be sure to follow the precautions below:

- When flammable liquid is sprayed or used for flushing or cleaning equipment, the turbine must be placed at least 20 feet (6.1 m) away from areas where hazardous concentrations of flammable vapors are likely to occur.
- Use additional air hose if necessary to ensure that the turbine is operated in a clean, dry, well-ventilated area.
- Never use or place the turbine inside a spray booth! Use this equipment outdoors or in extremely well-ventilated areas.
- Avoid all ignition sources such as static electricity from plastic drop cloths, open flames such as pilot lights, hot objects such as cigarettes, arcs from connecting or disconnecting power cords, and arcs from turning light switches on and off. Extinguish or remove all sources of ignition.

1. Turn turbine on a few minutes before spraying to warm-up.

NOTE: Turn turbine off when not in use. Turbine does not shut off automatically.

2. Be sure the turbine filter is clean before operating. See **Turbine Filter Maintenance** on page 13.

Cold Weather Operation

The HVLP compressor/cart uses a diaphragm compressor. When new, the diaphragm may become stiff in cold weather. If cold enough, the diaphragm will not allow the compressor motor to start (the unit will hum). If this occurs, follow these steps:

1. Turn turbine and compressor OFF.
2. Unplug turbine from power source.
3. Pinch and remove filter by hand. Clean or replace if dirty.
4. Hand spin cooling fan on compressor for a few revolutions.
5. Reinstall filter.
6. Plug in turbine.
7. Turn turbine and compressor ON. If necessary, repeat procedure.

Adjust Pattern Direction and Shape

Spray pattern direction and shape are determined by 3 different positions the air cap. See Fig. 5. Rotate air cap as needed to achieve desired pattern.

NOTE: Do not loosen air cap retaining ring to change patterns unless air cap is set to its widest pattern. See Fig. 10 on page 9.

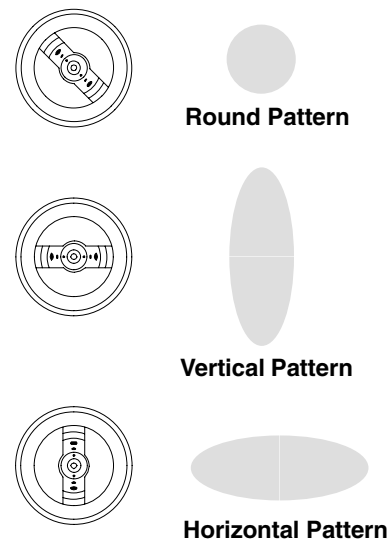

Fig. 5

02847

Setup

Adjust Spray Pattern

Select fluid set for fluid to be sprayed. If needed, see pages 10 and 11 to determine correct fluid set.

! WARNING

Do not exceed the gun's 50 psi (0.35 MPa, 3.5 bar) Maximum Inlet Fluid Pressure and 100 psi (0.7 MPa, 7 bar) Maximum Inlet Air Pressure. Higher pressures can cause parts to rupture and result in serious injury or property damage.

To establish correct fluid flow:

1. Turn fluid adjustment knob (20) counterclockwise until you cannot feel any restriction of trigger movement. See Fig. 6.

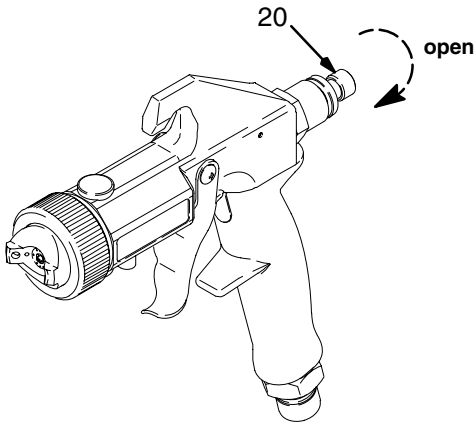

Fig. 6

05292

2. For remote pressure pot, hold gun parallel to floor and adjust fluid pressure at 8 to 10 inch (203 to 254 mm) fluid stream. See Fig. 7.

For 2-quart remote pressure pot:
Set at 4 to 6 psi (0.28 to 0.42 bar).

For 2¹/₂-gallon remote pressure pot:
Set at 8 to 10 psi (0.56 to 0.70 bar).

Note: Heavier fluids or longer fluid hoses require greater pressures.

! WARNING

Over-pressurizing the accessory remote pressure pots can cause serious injury. To reduce the risk, never exceed 50 psi (0.35 MPa, 3.5 bar) Maximum Inlet Fluid Pressure.

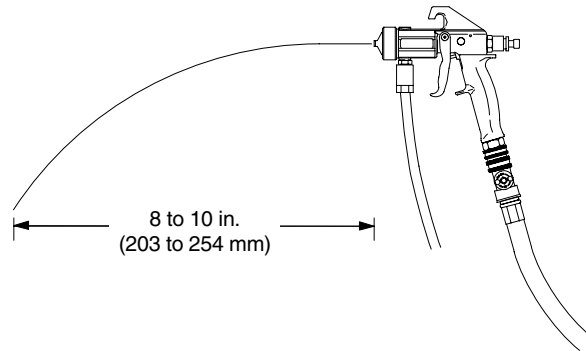

Fig. 7

05284

3. If further gun fluid adjustment is needed, turn fluid adjustment knob (20) clockwise to reduce volume of fluid output. See Fig. 8.

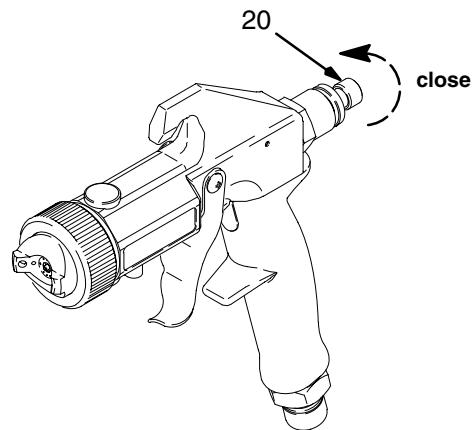

Fig. 8

05292

! CAUTION

Restricting the trigger and fluid needle travel by continuously spraying with the fluid adjustment knob closed (*turned clockwise*), will cause accelerated abrasive wear on the fluid needle and wear on the trigger.

For best results, adjust fluid flow at the pressure source or use a different size needle/nozzle/air cap combination.

Setup

To establish correct air flow:

4. Test spray pattern and atomization while holding gun about 6 to 8 inches (150 to 200 mm) from test piece.
5. Air Control Valve (M) on end of turbine hose controls both atomizing air and pressure in spray gun cup. See Fig. 9. Adjust air control valve as needed.

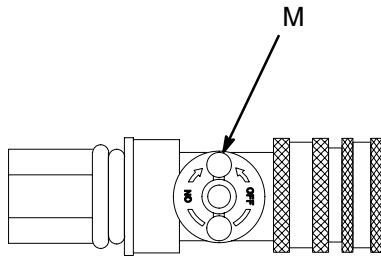

Fig. 9

02850

NOTES:

- Control over-spray mist by using only as much air as necessary to spray fluid. Lighter fluids require less air.
- If atomization is still unacceptable, fluids may be thinned further or a different fluid set may be required. See pages 10 and 11 to determine fluid set or page 5 to prepare fluid.

Adjust Pattern Size

Change pattern size by turning air cap retaining ring **in** for a wide pattern or **out** for a narrow pattern. See Fig. 10.

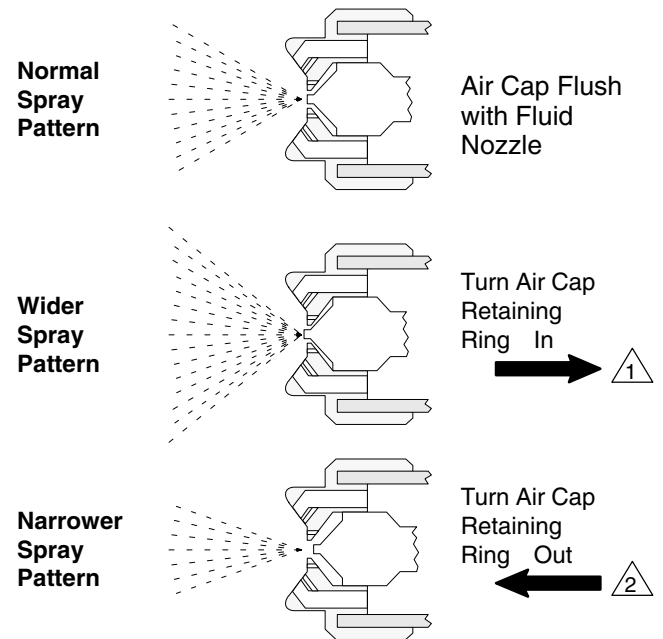

1 Turning air cap **in** too far will retard atomization.

2 Turning air cap **out** too far, will stop fluid or cause flutter.

Fig. 10

02851

Setup

Contractor Fluid Set Chart

Use this chart to determine Fluid Set for specific contractor application. See Fig. 11.

Fluid Set P/N & Size	Fluid Set Components			Type of Fluid**	Fluid Usage
	(A) Air Cap	(B) Nozzle	(C) Needle		
240112 #2 (0.8 mm)	240490	192911	192916	light 14 to 18 sec.	Fine finish work with stains, lacquers, water-borne lacquers
240113* #3 (1.3 mm)	240491	192912	192917	light – medium 18 to 22 sec.	Medium speed application with lacquers, enamels, urethanes, and varnish
240114 #4 (1.8 mm)	240492	192913	192918	medium 20 to 26 sec.	Medium to high speed industrial finishes
240115 #5 (2.2 mm)	240493	192914	192919	heavy 22 to 26 sec.	Heavy output with lacquer and enamels, latex and oil wall paints
240116 #6 (2.5 mm)	240494	192915	192920	heavy 26+ sec.	Wax base stripper, sound deadeners, latex paint, multi-color

* Standard fluid set

** Fluid measured with a #4 Ford cup (Part No. M70702)

Automotive Fluid Set Chart

Use this chart to determine Fluid Set for specific automotive application. See Fig. 11.

Fluid Set P/N & Size	Fluid Set Components			Fluid Usage
	(A) Air Cap	(B) Nozzle	(C) Needle	
240117 0.5/0.5M mm	M70434† 0.5 mm	M70446	M70453	Ultra fine finish with automotive touch-up, spot jobs
240118 0.7/0.7M mm	M70437† 0.7 mm	M70447	M70455	Fine finish work with all automotive finishes, color matching, automotive base coat
240113* #3 (1.3 mm)	240491	192912	192917	Normal output with enamels, urethanes, zinc chromate, automotive primers
240119 #1 (1.0 mm)	M70439	M70448	M70457	Medium-speed application with all automotive finishes

* Standard fluid set

† Multi-hole air cap

Setup

Using Fluid Set Charts

Turbine Spray Gun includes a #3 fluid set, Part No. 240113. **The size of air cap, fluid nozzle, and fluid needle are marked on parts.**

Use fluid set charts on page 10 to order different size fluid set or to find part number of individual components of fluid set. Charts identify fluid sets used in contractor and automotive applications.

Fluid sets include air cap (A), nozzle (B), and needle assembly (D). See Fig. 11.

NOTE: To order other replacement parts for gun, see parts drawings and parts lists for gun model on pages 20 to 23.

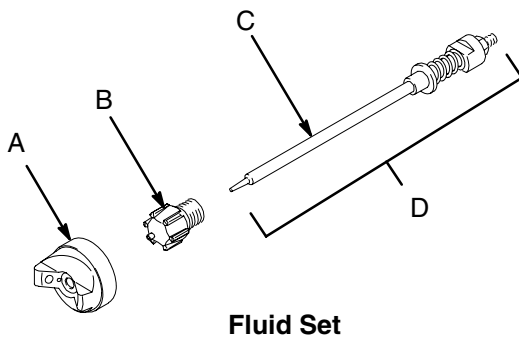

Fig. 11

02981

Selecting Fluid Set

Turbine spray gun fluid sets range in size to provide different fluid flow rates. Selection charts on page 10 show recommended combinations based on fluid viscosities, flow rates, and usage.

As a general guideline, use fluid nozzle that will give required flow with needle fully triggered at lowest fluid pressure.

For low flow rates or light viscosity fluid, select smaller nozzle sizes.

For high flow rates or high viscosity fluid, select larger nozzle sizes.

To eliminate mist, use air cap one size larger than fluid nozzle. Use of smaller size air cap produces finer finish, but can increase mist.

For very fine finish work (automotive, furniture, etc.), order air cap two sizes smaller than needle and nozzle. 0.5M mm or 0.7M mm multi-hole air caps are recommended for automotive finishes. See **Automotive Fluid Set Chart** on page 10.

For narrow fan pattern (wood finishing), order 0.5W mm, 0.7W mm, or 1.0W mm narrow fan pattern air cap. See chart below for part numbers.

Narrow Fan Pattern Air Caps

Air Cap P/N	Size
M70435	0.5W mm
M70438	0.7W mm
M70441	1.0W mm

Shutdown

Pressure Relief Procedure

⚠ WARNING

PRESSURIZED EQUIPMENT HAZARD

The equipment stays pressurized until pressure is manually relieved. To reduce the risk of a serious injury from pressurized fluid, accidental spray from the gun, or splashing fluid, follow the **Pressure Relief Procedure** whenever you:

- are instructed to relieve the pressure,
- stop spraying,
- check or service any of the system equipment,
- or install or clean the fluid nozzles.

1. When spraying is finished, turn off air supply to gun.
2. Turn off turbine sprayer.

⚠ WARNING

The turbine hose outlet may be hot. Carefully check the hose end before removing the hose.

3. If using remote pressure pot:
Relieve pressure by following these steps:
 - a. Turn off air supply to pressure pot.
 - b. $2\frac{1}{2}$ -gallon remote pressure pot:
Pull pressure relief valve ring (206c) until pressure is completely relieved.
2-quart remote pressure pot:
Turn **out** pressure relief knob (113) about one turn. Wait until pressure is completely relieved before removing cover. Close knob. See Fig. 12.

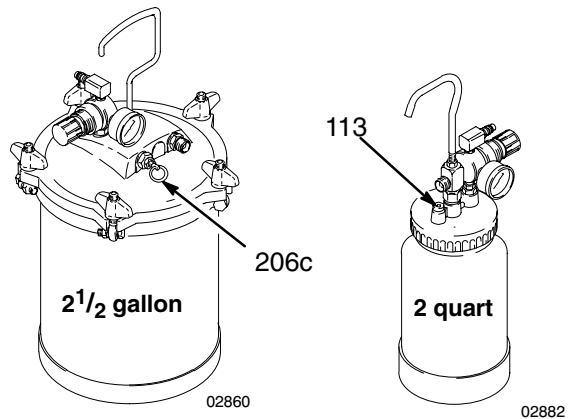

Fig. 12

NOTE: Elevate spray gun and pull trigger. This will allow fluid in fluid hose to drain back into remote pressure pot.

4. If using a spray gun cup:
Unlatch cup cover and loosen or remove cup from cover to relieve cup pressure.
5. Clean spray gun and cup as instructed on page 14.

Spraying Techniques

General Spraying Techniques

- Select proper fluid set. To determine correct fluid set see charts on page 10.
- When fluid is first applied, start with fluid nozzle and air cap adjusted to “normal spray pattern” position. Then adjust as needed. See Fig. 10 for pattern size adjustment.
- Keep gun perpendicular to surface and maintain consistent distance of approximately 6 to 8 inches (150 to 200 mm) from object being sprayed. See Fig. 13.
- Always have spray gun in motion before triggering. Move spray gun across workpiece in straight, smooth, stroke. Maintaining speed and distance. Release trigger at end of stroke.
- To obtain even finish, overlap previous strokes by 50%.
- Apply full, wet coat whenever possible.

Automotive Spraying Techniques

- When blending spots, work from outside in.
- Two lengths of 20 foot (6.1 m) hose are recommended when applying automotive finish coats. Additional hose allows air to cool for better flow.

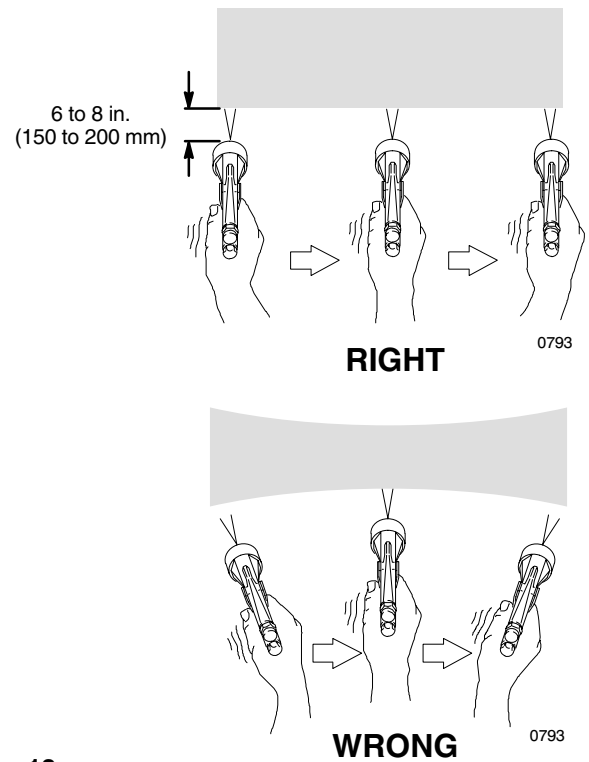

Fig. 13

Maintenance

Turbine Filter Maintenance

Turbine systems are lifetime lubricated. The only maintenance required is filter cleaning and replacement.

Turbine main filter and pre-filter must be clean at all times to provide sufficient air flow to cool motor and atomize fluid. Check pre-filter cleanliness daily. Check main paper filter weekly. Clean as necessary.

NOTE: To check filter, turn on turbine and place piece of paper against pre-filter. If air intake holds paper in place, filter is okay.

To clean main filter:

1. Turn off and unplug turbine.
2. Loosen four main filter screws, remove filter retainers and pre-filter.
3. Remove main filter and clean by one of the following methods:
 - Tap filter gently on flat surface, dirty side down.
 - Direct maximum of 100 psi (0.7 MPa, 7 bar) compressed air through filter panel in opposite direction of arrows on side of filter.
 - Soak filter 15 minutes in water and mild detergent. Rinse filter until clean. Air dry filter; do not use compressed air.

⚠ WARNING

To avoid damage to turbine and possible electric shock, never install damp filter in turbine.

Maintenance

Flushing Spray Gun Using Remote Pressure Pot

⚠ WARNING

The spray gun cups and accessory remote pressure pots remain pressurized until pressure is manually relieved. To reduce the risk of serious injury from pressurized fluid or accidental spray from the gun, always relieve pressure in the cup or pressure pot before checking or servicing any part of the spray system; before installing, cleaning or changing fluid nozzles; before loosening or removing the accessory remote pressure pot cover; and whenever you stop spraying.

NOTES:

- Check for any fluid leakage from gun and fluid hoses. Tighten fittings or replace equipment as needed.
- Flush gun before changing colors and whenever you are done spraying.

⚠ CAUTION

Clean all parts with a solvent compatible with the fluid being sprayed and compatible with the spray gun and cup or accessory remote pressure pot wetted parts. See **Technical Data** on page 25.

1. Turn off air supply to gun.
2. Relieve pot pressure as follows:
 - a. Turn off air supply to pressure pot.
 - b. 2¹/₂-gallon remote pressure pot:
Pull pressure relief valve ring (206c) until pressure is completely relieved.
2-quart remote pressure pot:
Turn **out** pressure relief knob (113) about one turn. Wait until pressure is completely relieved before removing cover. Close knob. See Fig. 12.
3. Fill pressure pot with compatible solvent.
4. Flush spray gun, using compressor air only. Point gun down into container and flush until solvent runs clean.

5. Relieve pot pressure, as described in Step 2.
6. Disconnect air and fluid hoses from gun.
7. Clean and lubricate gun as instructed starting on page 15.

Flushing Spray Gun and Cup

1. Turn off air supply to gun.
2. Unlatch cup cover and remove cup from cover.
3. Turn air cap to round pattern position. Turn air control valve half open to reduce solvent mist. See Fig. 14.

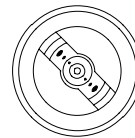

Air Cap Round Pattern Position

Fig. 14

02847

4. Fill empty cup with about 1 1/2 inches (38.1 mm) of compatible solvent and reinstall cup. Be sure cover is secured.
5. Turn on air to gun.
6. Point gun down into container and flush until solvent runs clean. See Fig. 15.

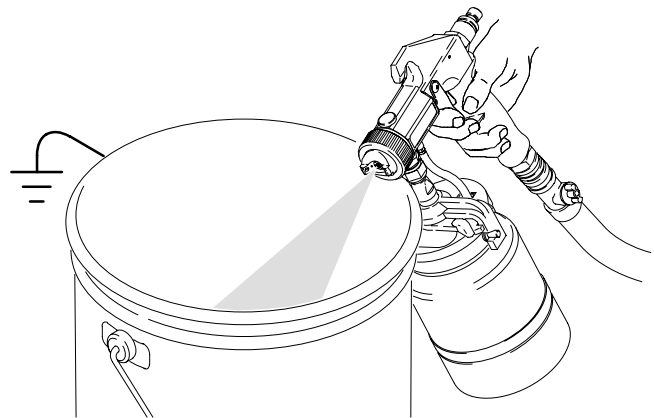

Fig. 15

05290AA

7. Turn off air to gun.
8. Disconnect air supply and remove cup from gun. Clean and lubricate gun as instructed on pages 15 and 16.

Maintenance

Clean Spray Gun

1. Clean gun and cup by hand with compatible solvent or place them in gun washer with trigger held open; cycle washer as necessary to clean gun.

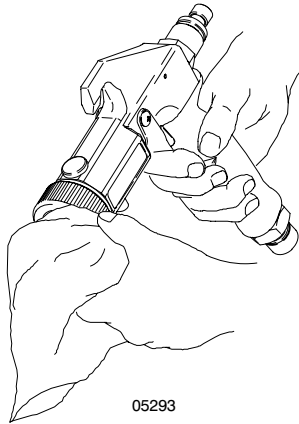

Fig. 16

2. Remove air cap retaining ring (29), air cap (27), spring and detent plate (25). See Fig. 17.
3. Trigger gun while removing fluid nozzle (19) with nozzle wrench (P), provided. See Fig. 17.
4. Remove gun fitting (22) from back of gun. Remove needle for cleaning.

CAUTION

Trigger the gun whenever you tighten or remove the nozzle. This keeps the needle seat away from the nozzle seating surface and prevents the seat from being scratched.

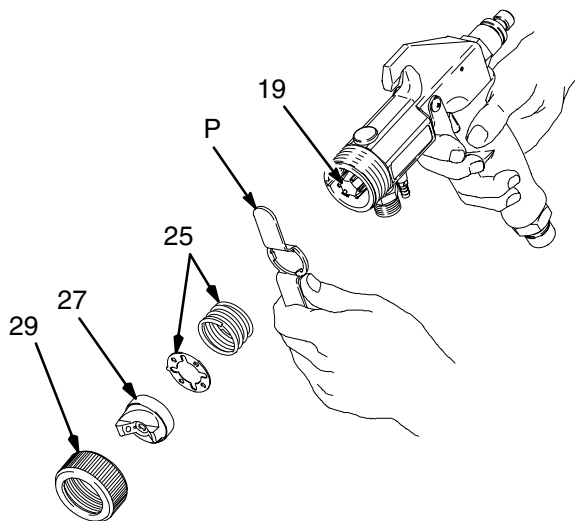

Fig. 17

05291

5. Soak air cap, detent plate and fluid nozzle in solvent. At a minimum, clean air cap and fluid nozzle daily. Use solvent and brush (R), provided. See Fig. 18. Some applications require more frequent cleaning. Keep all air cap holes clean.

CAUTION

Clean air cap horn holes with a non-metallic item to avoid permanently damaging them.

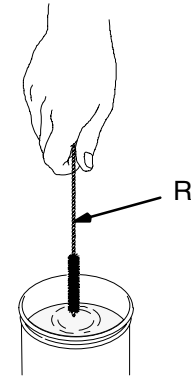

Fig. 18

02856

6. With gun pointed down, clean front of gun, using brush and solvent.
7. Trigger gun while installing fluid nozzle (19) with nozzle wrench (P). See Fig. 17.
8. Install spring (25) into front of gun.
9. Install detent plate (25) into gun housing with open sockets (S) facing up; align detent plate tab (T) with notch in gun housing. See Fig. 19.
10. Install air cap (27), aligning air cap balls (U) with detent plate sockets (S). See Fig. 19. Secure air cap with air cap retaining ring (29).

NOTE: If installed correctly, air cap will snap into four definite positions, with no loose rotation.

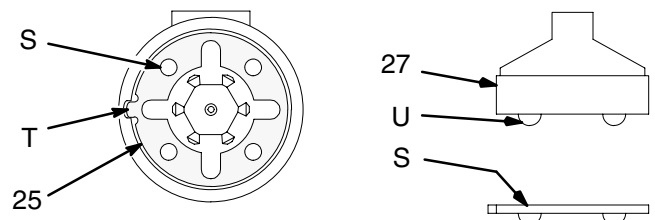

Fig. 19

02966

11. Lubricate gun after cleaning it as instructed on page 16.

Service

Lubricate Spray Gun

After cleaning or servicing gun, lubricate parts indicated in Fig. 20 with silicone-free spray gun lubricant or similar material.

- All threaded areas (A)
- Trigger screws (B)
- Trigger axle (C)
- Fluid needle assembly (D) — where indicated

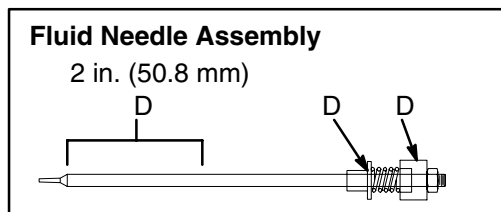
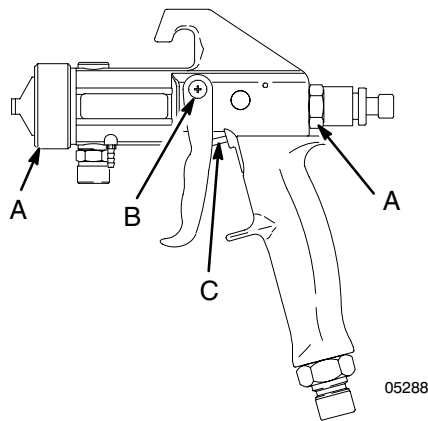

Fig. 20 02949, 02950

Replace and Adjust Needle

The needle may need to be adjusted whenever you change nozzle/needle sizes or to compensate for wear.

To replace needle:

1. Fig. 21. Remove fitting (22) and spring (23-not shown) from back of gun.
2. Remove needle (14).
3. Insert new needle (14).

To adjust needle:

4. Hold needle (14) with thumb and push upper trigger pin (A) with index finger. Fig. 21. Trigger pin must travel approximately 1/16 in. (2 mm) under light spring pressure.
5. If there is not 1/16 in. of travel, loosen adjustment nut (18) and turn drum (17) until trigger pin (A) has about 1/16 in. (2 mm) free travel before needle (14) starts to move.
6. Lock adjustment nut (18).
7. Make sure spring (23) is in place in fitting (22), then install fitting. Hand-tighten fitting.

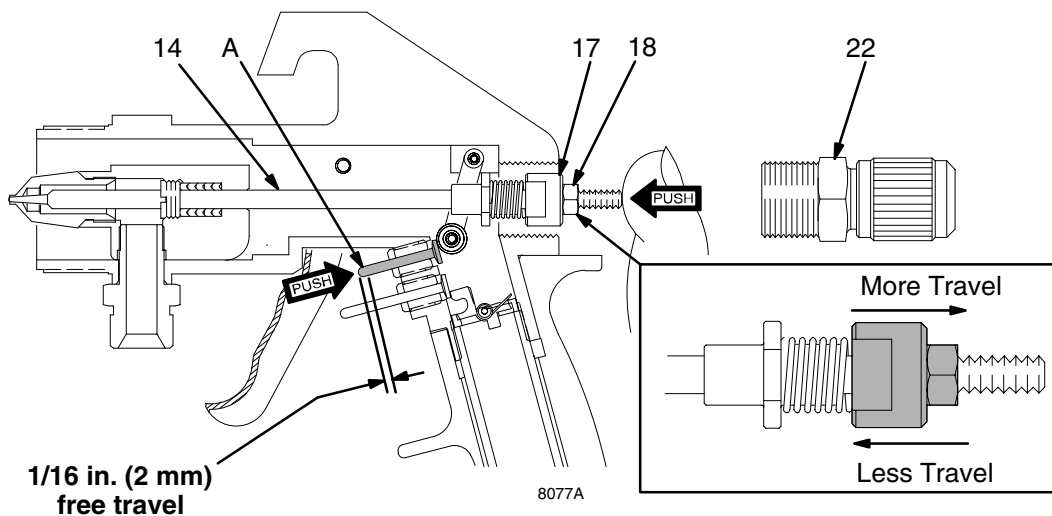

Fig. 21 Model 980 shown

8669A

Service

⚠ CAUTION

Trigger the gun whenever you tighten or remove the nozzle. This keeps the needle seat away from the nozzle seating surface and prevents the seat from being scratched.

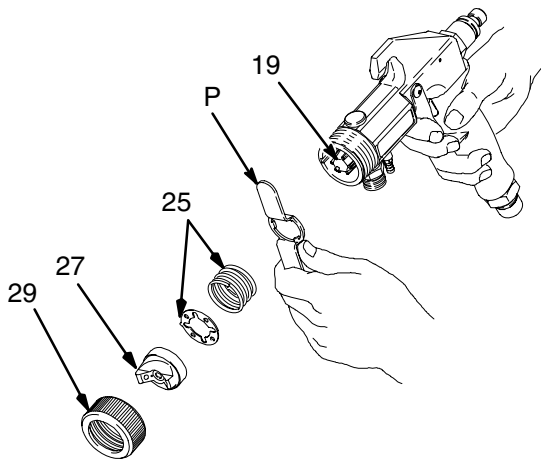

Fig. 22

05291

8. Trigger gun while slightly turning packing nut (9) clockwise with packing wrench (K), provided. See Fig. 23. This will compress packings.

The packings need very little pressure to seal well. If needle binds, packings are too tight; back packing nut off 1/16 turn. Needle should then move freely. If packings are over-tightened, they may be damaged and need to be removed and replaced.

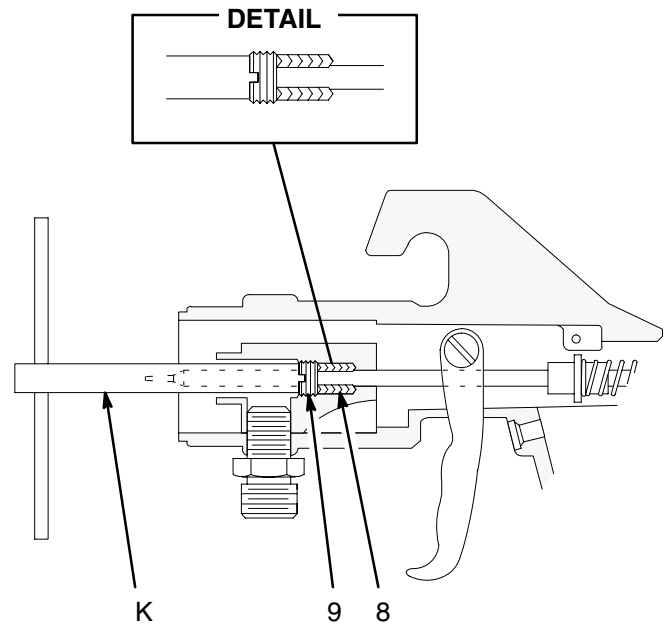

Fig. 23

02858

9. Trigger gun while installing fluid nozzle (19) with nozzle wrench (P). See Fig. 22.
10. Install spring (25) into front of gun.
11. Install detent plate (25) into gun housing with open sockets (S) facing up; align detent plate tab (T) with notch in gun housing. See Fig. 24.
12. Install air cap (27), aligning air cap balls (U) with detent plate sockets (S). See Fig. 24. Secure air cap with air cap retaining ring (29).

NOTE: If installed correctly, air cap will snap into 4 definite positions, with no loose rotation.

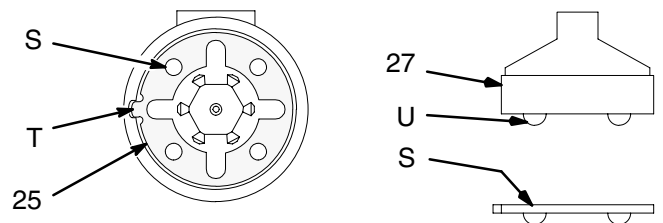

Fig. 24

02966

Troubleshooting

Spray Finish Problems

PROBLEM	CAUSE	SOLUTION
Orange peel finish — Paint surface not smooth	Paint droplets too large.	<ul style="list-style-type: none"> ● Maintain proper spraying distance; see page 13. ● Keep the turbine air filters clean to allow full air flow. See page 13. ● Do not use an air hose that is too long to provide sufficient atomization pressure. ● If droplets are still too large, reduce the fluid or use a smaller air cap.
	Paint droplets drying too fast to properly flow out of gun.	Keep the object being sprayed out of direct sunlight. When spraying in warmer temperatures, use a slower evaporating solvent or a retarder.
	Cold weather spraying.	<p>Keep the fluid and the object being sprayed as close to room temperature as possible. When sprayed on a cold surface, most paints will become too thick to flow properly.</p> <p>See Cold Weather Operation on page 7.</p>
Blushing — Clear coatings appear milky	Moisture condensation is trapped in the lacquer when spraying in hot, humid conditions.	<ul style="list-style-type: none"> ● Allow the turbine to warm up a few minutes before spraying. ● Store the lacquer off concrete floors, at room temperature. ● Apply lighter coats and allow for proper drying time. ● Use a slower evaporating solvent or retarder. ● Do not spray in windy conditions.
Fish eyes — Small pools on painted surface that will not fill	Silicone contamination from lubricants, grease, polish, or waxes on the surface being sprayed.	Clean all parts with a cleaning solvent; use a solvent rag and a clean rag to wipe with. Replace rags as needed. If the problem persists, use a fish eye eliminator.
Runs and sags	Applying too much paint per pass for the drying conditions.	<ul style="list-style-type: none"> ● Move the gun faster or decrease the fluid flow. ● Maintain proper spraying distance; see page 13. ● Reduce the amount of thinner or use a faster drying thinner.
Solvent pops or bubbles	Sprayed surface drying before solvent gas can be released.	<ul style="list-style-type: none"> ● Apply fluid in lighter coats to allow for proper evaporation. ● Use the recommended thinners. ● Follow the solutions, above, for <i>Orange peel finish — paint droplets too large</i>.

Troubleshooting

Spray Gun Problems

PROBLEM	CAUSE	SOLUTION
No or slow fluid flow, intermittent spray, or fluttering spray	Proper size fluid set is not being used.	Select the proper fluid set for the fluid being sprayed. See page 10.
	Air cap is adjusted too far forward.	Adjust the air cap to "normal" position. See page 9.
	Gun fluid nozzle is not tight enough, is blocked by dried paint, or is damaged.	Tighten, clean or replace fluid nozzle.
	Cup or pressure pot cover is not tight enough or gasket is damaged.	Tighten cover or replace gasket.
	Cup or pressure pot fluid tube blocked by dried paint or is damaged.	Clean or replace fluid tube.
	Air flow to cup is blocked.	To check: remove the cup (leave cover connected), trigger the gun and check for air flow out of the cup lower pressure tube. If air is not flowing freely, clean the air passage tubes.
	Needle packings are not properly adjusted. Fluid loss though the packings will effect fluid pressure and cause a fluid build-up in the gun body.	Clean the gun body with solvent and the brush provided. Adjust the needle packings as instructed on page 17.
	Needle is not properly adjusted. Fluid flow will be restricted if there is too much free travel between the trigger and needle.	Adjust the needle as instructed on page 16.
Fluid leaks at fluid nozzle after the trigger is released	Needle is not seating in the fluid nozzle.	<ul style="list-style-type: none"> • Check for a loose fluid nozzle or a bent nozzle or needle; tighten the nozzle or replace parts as needed. • Check the needle adjustment; see page 16. • Check the needle packings adjustment; see page 17.
Poor spray pattern	Air cap horn holes and/or fluid nozzle plugged.	Soak air cap and/or fluid nozzle in solvent. Clean air cap horn holes with non-metallic item to avoid permanently damaging them. See page 15.

Parts for Model 960

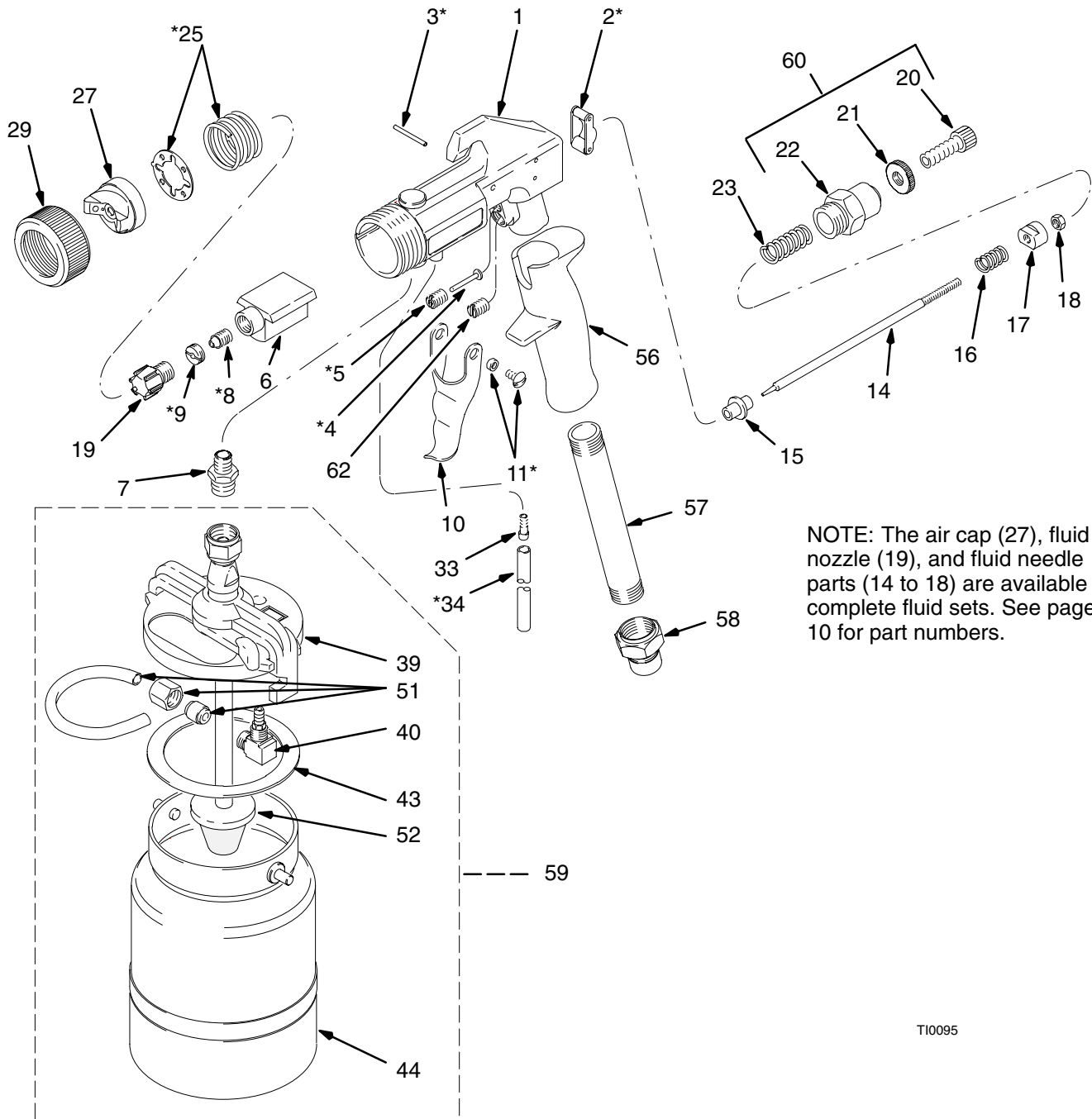

NOTE: The air cap (27), fluid nozzle (19), and fluid needle parts (14 to 18) are available as complete fluid sets. See page 10 for part numbers.

T10095

Parts for Model 960

- 240080 Model 960, without fluid set
- 240083 Model 960, with #3 fluid set
- 240084 Model 960, with #4 fluid set
- 240085 Model 960, with #5 fluid set
- 243920 Model 960, with 2.0 fluid set

Ref No.	Part No.	Description	Qty	Ref No.	Part No.	Description	Qty
1	193103	GUN BODY	1	25*	240280	DETENT PLATE/SPRING KIT, air cap	1
2*	M73004	ACTUATOR, needle	1	27	–	AIR CAP (See chart on page 10 for part number)	1
3*	M70388	PIN, actuator	1	29	240279	RING, pattern control	1
4*	193123	PIN, trigger	1	33	M70394	STEM, air	1
5*	193100	GUIDE, pin	1	34*	240263	HOSE, air pressure	1
6	M70384	MANIFOLD, fluid	1	39	240510	LID ASSY	1
7	M70401	FITTING, fluid inlet	1	40	M71677	ELBOW, with stem	1
8*	M70381	PACKING KIT, fluid; PTFE	1	43	240265	GASKET, cup; (5 pack)	1
9*	M70380	SCREW, adjustment	1	44	240262	CUP; 1 quart (1 liter)	1
10	193098	TRIGGER	1	51	M71680	KIT, air pressure	1
11*	M70386	SCREW/BUSHING ASSY., trigger	2	52	240267	STRAINER, material (3-pack)	1
14	–	FLUID NEEDLE (See chart on page 10 for part number)	1	55	M70612	TOOL KIT; (<i>not shown</i>) Includes a brush, T-wrench, & nozzle wrench	1
15	M70403	RING, driving	1	56	193102	HANDLE, gun	1
16	M70404	SPRING, driving ring	1	57	193099	TUBE, gun, handle	1
17	M70405	DRUM, needle adjustment	1	58	M73003	COUPLING, disconnect, quick	1
18	M70406	NUT	1	59	240260	KIT, 1-quart cup with cover	1
19	–	FLUID NOZZLE (See chart on page 10 for part number)	1	60	M70409	KIT, fluid regulating	1
20	M70467	SCREW, fluid regulating	1	61	M71149	SETSCREW, plug (not shown)	1
21	M70466	RING, locking	1	62	193721	PLUG	1
22	M70465	FITTING, gun	1				
23	M70407	SPRING, needle return	1				

* These parts are included in Repair Kit M73528, which may be purchased separately.

Parts for Models 960GF.5 & 960GF.75

NOTE: Model 960GF.5 includes 1/2-quart (1/2-liter) cup
 Model 960GF.75 includes 3/4-quart (3/4-liter) cup

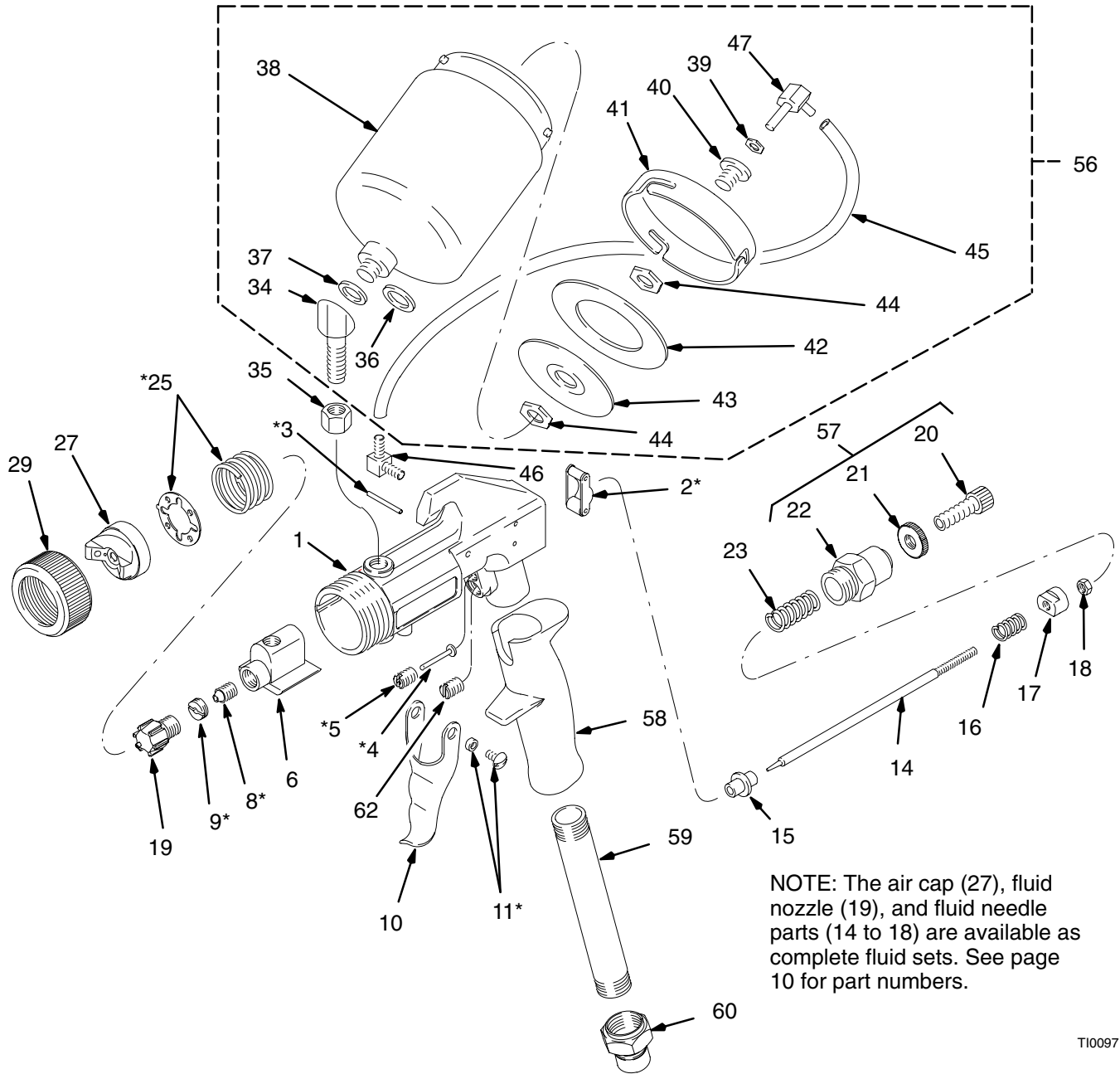

NOTE: The air cap (27), fluid nozzle (19), and fluid needle parts (14 to 18) are available as complete fluid sets. See page 10 for part numbers.

T10097

Parts for Models 960GF.5 & 960GF.75

240530 Model 960GF.5, without fluid set

240532 Model 960GF.75, without fluid set

Ref No.	Part No.	Description	Qty	Ref No.	Part No.	Description	Qty
1	193339	GUN BODY	1	34	M71031	FITTING, fluid inlet	1
2*	M73004	ACTUATOR, needle	1	35	M71030	NUT	1
3*	M70388	PIN, actuator	1	36	M71033	WASHER, brass	1
4*	193123	PIN, trigger	1	37	M71032	GASKET	1
5*	193100	GUIDE, pin	1	38	M71035	CUP, 1/2 quart (1/2 liter); Model 960GF2 only	1
6	M70384	MANIFOLD, fluid	1		M71034	CUP, 3/4 quart (3/4 liter); Model 960GF3 only	1
8*	M70381	PACKING KIT, fluid; PTFE [®]	1	39	M71040	NUT	1
9*	M70380	SCREW, adjustment	1	40	M71039	BOLT, cup over	1
10	193098	TRIGGER	1	41	M71037	COVER, cup over	1
11*	M70386	SCREW/BUSHING ASSY., trigger	2	42	M71427	GASKET, cup, polyethylene, (5 pack)	1
14	–	FLUID NEEDLE (See chart on page 10 for part number)	1	43	M71021	HOOD, cup	1
15	M70403	RING, driving	1	44	M71019	NUT	2
16	M70404	SPRING, driving ring	1	45	M71045	HOSE, air pressure	1
17	M70405	DRUM, needle adjustment	1	46	M70393	ELBOW CONNECTOR, hose	1
18	M70406	NUT	1	47	M71046	ELBOW CONNECTOR, hose	1
19	–	FLUID NOZZLE (See chart on page 10 for part number)	1	55	M70612	TOOL KIT; (<i>not shown</i>) Includes a brush, T-wrench, & nozzle wrench	1
20	M70467	SCREW, fluid regulating	1	56	M71047	KIT, cup over, 1/2 liter	1
21	M70466	RING, locking	1	57	M70409	KIT, fluid regulating	1
22	M70465	FITTING, gun	1	58	193102	HANDLE, gun	1
23	M70407	SPRING, needle return	1	59	193099	TUBE, gun, handle	1
25*	240280	DETENT PLATE/SPRING KIT, air cap	1	60	M73003	COUPLING, disconnect, quick	1
27	–	AIR CAP (See chart on page 10 for part number)	1	62	193721	PLUG	1
29	240279	RING, pattern control	1				

* *These parts are included in Repair Kit M73528, which may be purchased separately.*

Parts for Model 960P

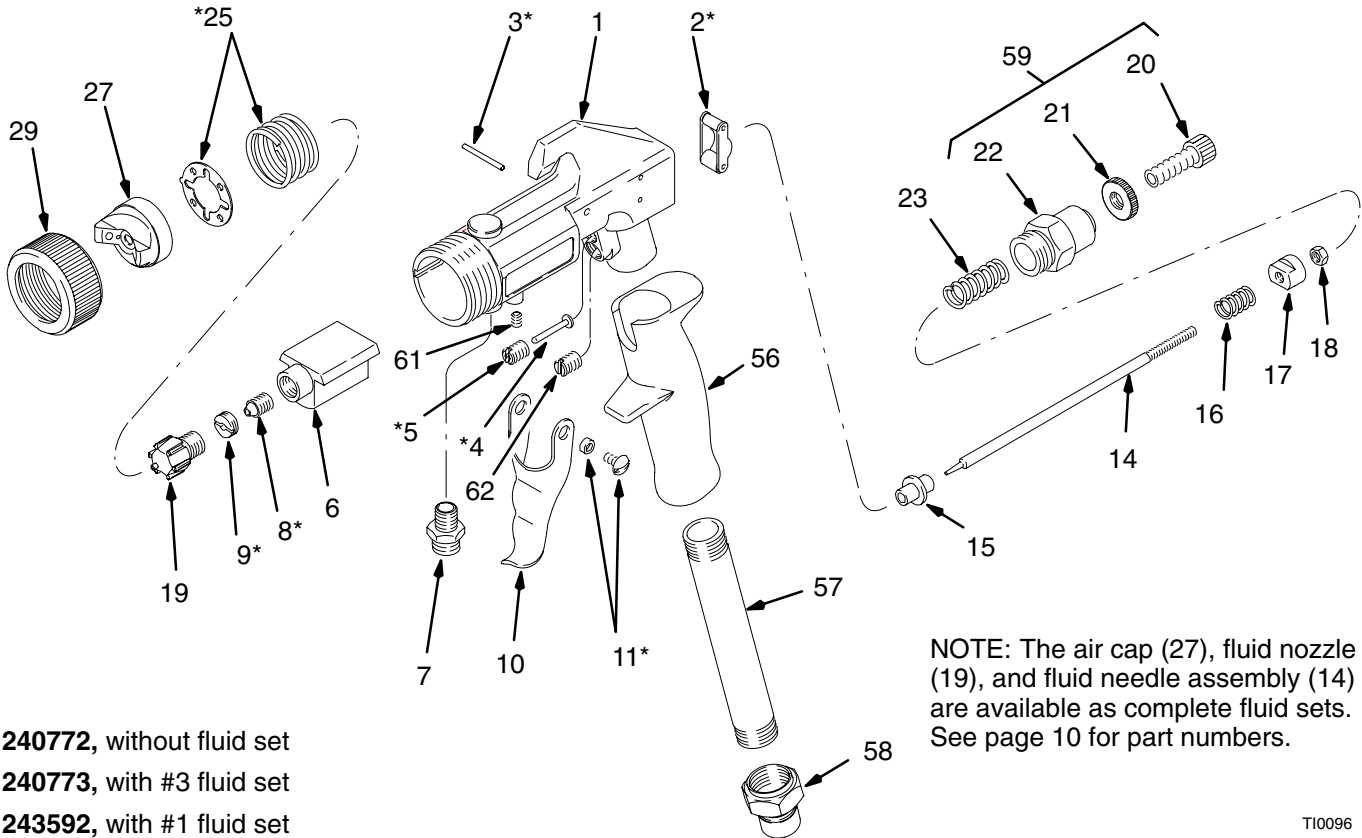

240772, without fluid set
 240773, with #3 fluid set
 243592, with #1 fluid set

NOTE: The air cap (27), fluid nozzle (19), and fluid needle assembly (14) are available as complete fluid sets. See page 10 for part numbers.

T10096

Ref No.	Part No.	Description	Qty	Ref No.	Part No.	Description	Qty
1	193103	GUN BODY	1	20	M70467	SCREW, fluid regulating	1
2*	M73004	ACTUATOR, needle	1	21	M70466	RING, locking	1
3*	M70388	PIN, actuator	1	22	M70465	FITTING, gun	1
4*	193123	PIN, trigger	1	23	M70407	SPRING, needle return	1
5*	193100	GUIDE, pin	1	25*	240280	DETENT PLATE/SPRING, air cap	1
6	M70384	MANIFOLD, fluid	1	27	-	AIR CAP (See chart on page 10 for part number)	1
7	M70401	FITTING, fluid inlet	1	29	240279	RING, pattern control	1
8*	M70381	PACKING KIT, fluid; PTFE	1	55	M70612	TOOL KIT; (not shown) Includes a brush, T-wrench, & nozzle wrench	1
9*	M70380	SCREW, adjustment	1	56	193102	HANDLE, gun	1
10	193098	TRIGGER	1	57	193099	TUBE, gun, handle	1
11*	M70386	SCREW/BUSHING ASSY., trigger	2	58	M73003	COUPLING, disconnect, quick	1
14	-	NEEDLE ASSY. (See chart on page 10 for part number)	1	60	M70409	KIT, fluid regulating	1
15	M70403	•RING, driving	1	61	M71149	SET SCREW, plug	1
16	M70404	•SPRING, driving ring	1	62	193721	PLUG	1
17	M70405	•DRUM, needle adjustment	1				
18	M70406	•NUT	1				
19	-	FLUID NOZZLE (See chart on page 10 for part number)	1				

* These parts are included in Repair Kit M70290, which may be purchased separately.

Accessories

Gun Cleaning Kit — M70612

Includes packing adjustment wrench and cleaning brush

Lubricant — 111265

4-oz (113-g) tube of sanitary (non-silicone) lubricant for fluid seals and wear areas

Cup Check Valve — M71007

Prevents cup from depressurizing after air is shut off to gun

Technical Data

Maximum inlet fluid pressure	50 psi (0.35 MPa, 3.5 bar)
Maximum inlet air pressure	100 psi (0.7 MPa, 7 bar)
Atomizing air pressure	10 psi (0.07 MPa, 0.7 bar)
Air inlet	Quick-disconnect
Fluid inlet	3/8 nps
Sound levels per ISO 3744	
Sound power level	less than 65.0 dB(A)
Sound pressure level	less than 65.0 dB(A)
Wetted parts	
Bare spray gun	stainless steel, PTFE, hard-coated aluminum
Spray gun cups	aluminum, polyethylene
2-quart accessory remote pressure pot	aluminum, polyethylene
2 ¹ / ₂ -gallon accessory remote pressure pot	steel with solvent-resistant finish, EPDM gasket (standard)

PTFE®

Graco Standard Warranty

Graco warrants all equipment manufactured by Graco and bearing its name to be free from defects in material and workmanship on the date of sale by an authorized Graco distributor to the original purchaser for use. With the exception of any special, extended, or limited warranty published by Graco, Graco will, for a period of twelve months from the date of sale, repair or replace any part of the equipment determined by Graco to be defective. This warranty applies only when the equipment is installed, operated and maintained in accordance with Graco's written recommendations.

This warranty does not cover, and Graco shall not be liable for general wear and tear, or any malfunction, damage or wear caused by faulty installation, misapplication, abrasion, corrosion, inadequate or improper maintenance, negligence, accident, tampering, or substitution of non-Graco component parts. Nor shall Graco be liable for malfunction, damage or wear caused by the incompatibility of Graco equipment with structures, accessories, equipment or materials not supplied by Graco, or the improper design, manufacture, installation, operation or maintenance of structures, accessories, equipment or materials not supplied by Graco.

This warranty is conditioned upon the prepaid return of the equipment claimed to be defective to an authorized Graco distributor for verification of the claimed defect. If the claimed defect is verified, Graco will repair or replace free of charge any defective parts. The equipment will be returned to the original purchaser transportation prepaid. If inspection of the equipment does not disclose any defect in material or workmanship, repairs will be made at a reasonable charge, which charges may include the costs of parts, labor, and transportation.

THIS WARRANTY IS EXCLUSIVE, AND IS IN LIEU OF ANY OTHER WARRANTIES, EXPRESS OR IMPLIED, INCLUDING BUT NOT LIMITED TO WARRANTY OF MERCHANTABILITY OR WARRANTY OF FITNESS FOR A PARTICULAR PURPOSE.

Graco's sole obligation and buyer's sole remedy for any breach of warranty shall be as set forth above. The buyer agrees that no other remedy (including, but not limited to, incidental or consequential damages for lost profits, lost sales, injury to person or property, or any other incidental or consequential loss) shall be available. Any action for breach of warranty must be brought within two (2) years of the date of sale.

Graco makes no warranty, and disclaims all implied warranties of merchantability and fitness for a particular purpose in connection with accessories, equipment, materials or components sold but not manufactured by Graco. These items sold, but not manufactured by Graco (such as electric motors, switches, hose, etc.), are subject to the warranty, if any, of their manufacturer. Graco will provide purchaser with reasonable assistance in making any claim for breach of these warranties.

In no event will Graco be liable for indirect, incidental, special or consequential damages resulting from Graco supplying equipment hereunder, or the furnishing, performance, or use of any products or other goods sold hereto, whether due to a breach of contract, breach of warranty, the negligence of Graco, or otherwise.

FOR GRACO CANADA CUSTOMERS

The parties acknowledge that they have required that the present document, as well as all documents, notices and legal proceedings entered into, given or instituted pursuant hereto or relating directly or indirectly hereto, be drawn up in English. Les parties reconnaissent avoir convenu que la rédaction du présente document sera en Anglais, ainsi que tous documents, avis et procédures judiciaires exécutés, donnés ou intentés à la suite de ou en rapport, directement ou indirectement, avec les procédures concernées.

ADDITIONAL WARRANTY COVERAGE

Graco does provide extended warranty and wear warranty for products described in the "Graco Contractor Equipment Warranty Program".

Graco Phone Number

TO PLACE AN ORDER, contact your Graco distributor, or call this number to identify the distributor closest to you:
1-800-690-2894 Toll Free

*All written and visual data contained in this document reflect the latest product information available at the time of publication.
Graco reserves the right to make changes at any time without notice.*

Sales Offices: Minneapolis, Detroit
International Offices: Belgium, Korea, Hong Kong, Japan

GRACO INC. P.O. BOX 1441 MINNEAPOLIS, MN 55440-1441
www.graco.com

PRINTED IN USA 308336 01/1994, Revised 08/2000