

Turbine Alternator Repair Kits

308034F

ENG

For repair of turbine alternator used with PRO Series Electrostatic Spray Guns, with PRO Pulse Electronic Fluid Meter, and with SuperCat™, Xtreme Mix™ 185, ProMix™ Easy, and ProMix™ I Proportioners. For professional use only.



Important Safety Instructions

Read all warnings and instructions in this manual.
Save these instructions.

Part No. 223688 Bearing Repair Kit

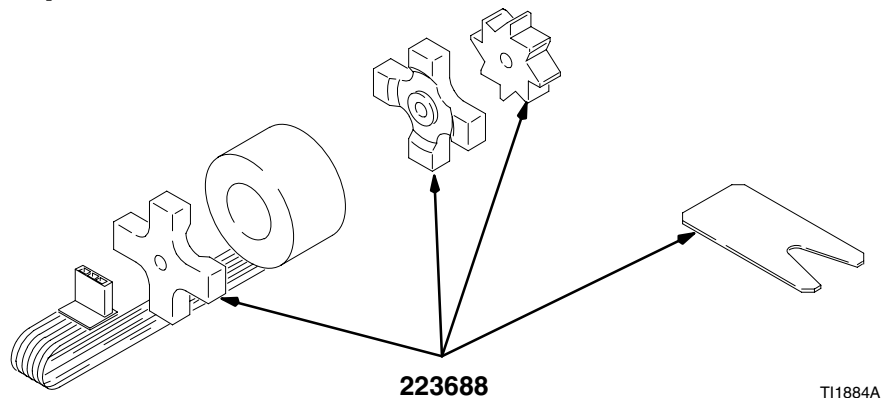

⚠ WARNING



FIRE, EXPLOSION, AND ELECTRIC SHOCK HAZARD

Improper grounding, poor air ventilation, open flames, or sparks can cause a hazardous condition and result in a fire, explosion, or electric shock.



- Electrostatic equipment must be used only by trained, qualified personnel who understand the requirements stated in this instruction manual and in the spray gun instruction manual.
- Read all the instruction manuals, tags, and labels before operating the equipment.



EQUIPMENT MISUSE HAZARD

Equipment misuse can cause the equipment to rupture, malfunction, or start unexpectedly and result in a serious injury.

INSTRUCTIONS



- Do not alter or modify this equipment. Use only genuine Graco parts and accessories.
- Check the equipment daily. Repair or replace worn or damaged parts immediately.
- Do not exceed the maximum working pressure of the lowest rated system component.
- Use fluids that are compatible with the equipment wetted parts. See the **Technical Data** section of all the equipment manuals. Read the fluid manufacturer's warnings.
- Comply with all applicable local, state, and national fire, electrical, and other safety regulations.

Turbine Alternator Service

Pressure Relief Procedure

⚠ WARNING

To reduce the risk of serious injury whenever you are instructed to relieve pressure, always follow the **Pressure Relief Procedure** in your spray gun manual or in the SuperCat instruction manual.

Disassembly

1. Relieve the pressure.
2. See your spray gun manual to remove the power cartridge. *For the SuperCat alternator*, remove six screws, open the housing, and remove the power cartridge.
3. Remove the turbine alternator.
4. Test the Coil: Measure the resistance between the two outer terminals of the 3-pin connector (101a). The resistance should be 2–5 ohms. Measure the resistance between each outer terminal of the 3-pin connector and the turbine alternator housing (B). The resistance should be infinite. If the readings vary from these values, replace the coil.
5. Remove the plastic plug (A).

6. **Pro Xs Models only:** Remove the retaining ring (H) from the turbine alternator housing (B).
7. Insert a center punch or small metal shaft into the hole in the back of the turbine alternator housing (B). Hold the housing and lightly tap out the turbine assembly (G).
8. Remove the larger bearing (2).
9. Slide the coil assembly (101) off the armature (D). Inspect the coil for wear or damage and replace if necessary.

NOTE: If only replacing the coil (101), continue by following steps 5 through 11 on page 3.

10. Using a drift punch or small metal shaft, tap the armature (D) out of the bearing (1) and fan (3).

⚠ CAUTION

To avoid demagnetization of the armature (D), never place it in contact with, or in close proximity to, any other armature or other ferromagnetic objects.

11. Clean the armature (D) shaft with a soft cloth. Inspect the shaft for wear or damage. Replace the armature (*part no. 217590*) if necessary.

Turbine Alternator Service

PRO 3500 / 4500 / 5500, PRO Pulse,
and SuperCat, Xtreme Mix 185, ProMix Easy,
and ProMix I Proportioners

KEY

- A Plug
- B Turbine Alternator Housing
- D Armature
- E O-Ring
- G Turbine Assembly
- H Retaining Ring (Pro Xs only)
- 1 Bearing
- 2 Bearing
- 3 Fan
- 101 Coil
- 101a 3-Wire Connector

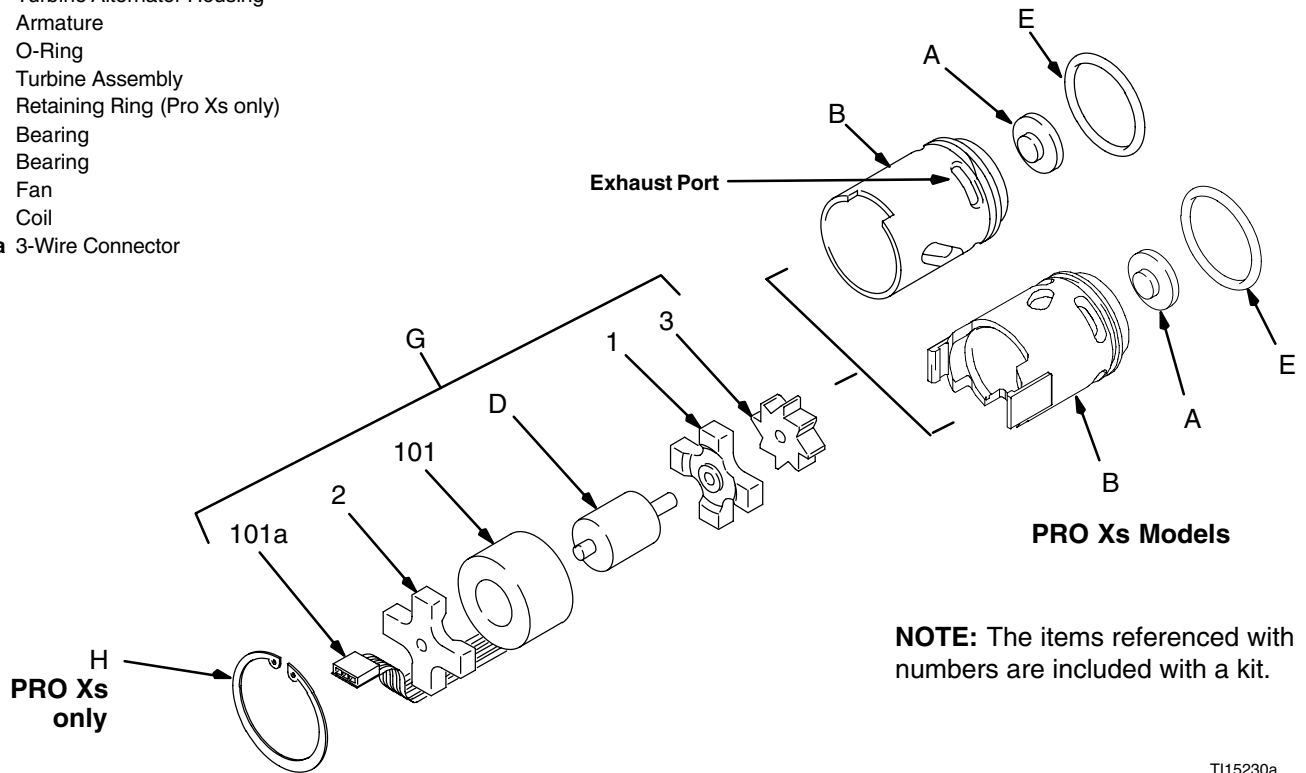

NOTE: The items referenced with numbers are included with a kit.

TI15230a

Fig. 1

Assembly

1. Remove the bearings (1 & 2) from the package and wipe the excess oil off with a soft cloth. Do not use solvent or air to wipe or blow off the excess oil.
2. Place the smaller bearing (1) [marked 197906] on the long end of the armature (D), with the machined groove in the bearing facing the armature.
3. Install the fan (3) on the long end of the armature (D), with the machined groove in the fan facing away from the armature.
4. Insert the spacing tool (4) between the fan (3) and bearing (1). Lightly tap on the end of the armature (D) until the fan is pressed up against the spacing tool and bearing. Remove the spacing tool. When properly installed, the bearing (1) should spin freely on the armature shaft.
5. Install the coil assembly (101) over the armature (D), with the 3-wire connector (101a) facing away from the fan (3).

6. Place the larger bearing (2) [marked 197907] on the end of the armature (D), with the machined groove in the bearing (2) facing in toward the armature. Align the legs of both bearings with each other.

NOTE: When installed, the bearing legs must not block the exhaust ports of the turbine alternator housing (B) or the gun will not operate properly.

7. Carefully slide the turbine alternator housing (B) over the turbine assembly (G), aligning the bearing legs between the exhaust ports of the housing. Push the turbine alternator housing onto the turbine assembly until the assembly is seated firmly in the turbine alternator housing.
8. **Pro Xs Models only:** Install the retaining ring (H) in the turbine alternator housing (B).
9. Press the plastic plug (A) onto the back of the turbine alternator housing (B).
10. Install the turbine alternator on the power cartridge as instructed in your spray gun manual.
11. Install the power cartridge and assemble the gun.

Parts

Part No. 223688 Turbine Alternator Bearing Repair Kit

Ref No.	Part No.	Description	Qty
1	197906	BEARING	1
2	197907	BEARING	1
3	179397	FAN	1
4	180064	SPACER TOOL	1

PRO 3500 / 4500 / 5500,
PRO Xs, PRO Pulse,
and SuperCat, Xtreme Mix 185, ProMix Easy,
and ProMix I Proportioners

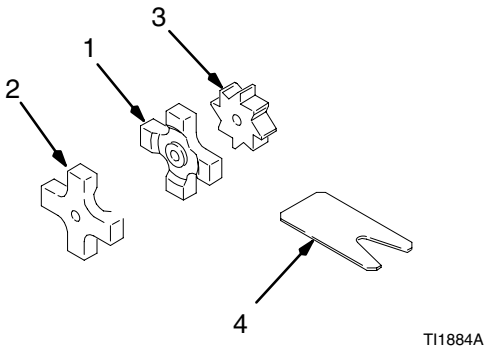

Part No. 223750 Turbine Alternator Coil Repair Kit (PRO 3500 / 4500 / 5500)

Ref No.	Part No.	Description	Qty
101	218166	COIL	1

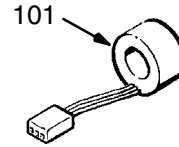

Part No. 244577 Turbine Alternator Coil (PRO Xs)

Ref No.	Part No.	Description	Qty
101	244577	COIL	1

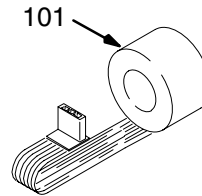

Graco Information

For the latest information about Graco products, visit www.graco.com.

TO PLACE AN ORDER, contact your Graco distributor or call to identify the distributor closest to you:

Phone: 612-623-6921 or **Toll Free:** 1-800-328-0211 **Fax:** 612-378-3505

All written and visual data contained in this document reflects the latest product information available at the time of publication.

Graco reserves the right to make changes at any time without notice.

Original instructions. This manual contains English. MM 308034

Graco Headquarters: Minneapolis

International Offices: Belgium, China, Japan, Korea

GRACO INC. P.O. BOX 1441 MINNEAPOLIS, MN 55440-1441

Copyright 1990, Graco Inc. is registered to ISO 9001

www.graco.com

Revised 02/2010