



INSTRUCTIONS

This manual contains important warnings and information.
READ AND RETAIN FOR REFERENCE

OWNER'S MANUAL

824-135

Rev. B

Supercedes Rev. A

ELECTRIC, 120 VAC

ULTIMATE[®] Mx 695

Airless Paint Sprayer

3000 psi (210 bar, 21 MPa) Maximum Working Pressure

Model 824-130, Series A

Upright basic sprayer only

Model 824-132, Series A

Lo-Boy basic sprayer only

Model 824-132

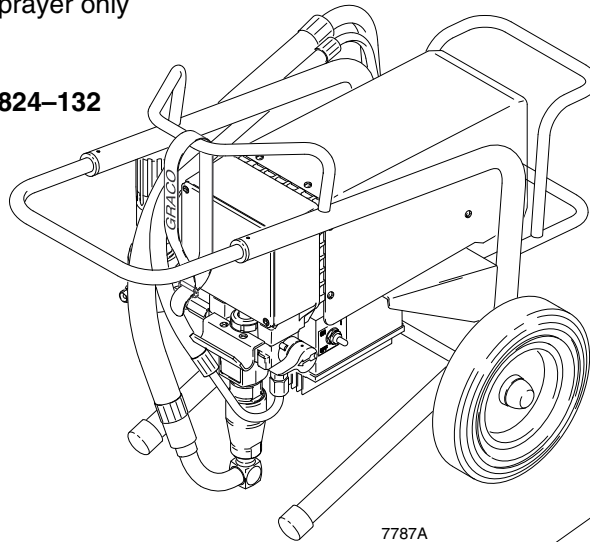

7787A

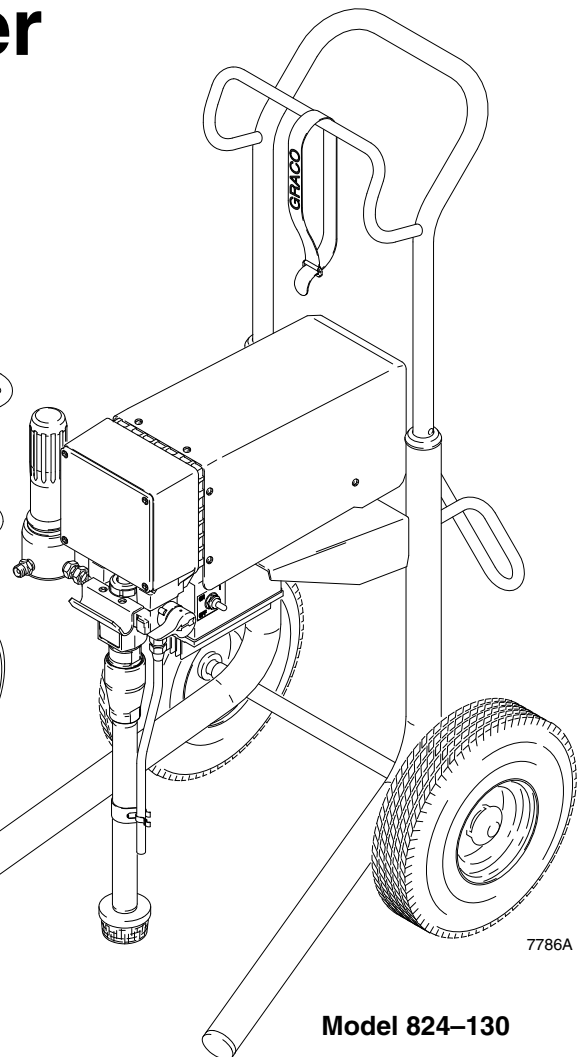

7786A

Model 824-130

Related Manuals

- Displacement Pump 308-815
- Fluid Filter 308-249

The **SHERWIN-WILLIAMS COMPANY, CLEVELAND, OHIO 44115**

©COPYRIGHT 1997, GRACO INC.

Table of Contents

Warnings	2	Power Supply Cord	25
Component Function and Identification	5	On/Off Switch	25
Setup	6	Drive Housing, Connecting Rod, Crankshaft	26
Startup	9	Pressure Transducer	28
Shutdown and Care	11	Pressure Transducer Seal	28
Flushing	12	Suction Hose	29
Troubleshooting	14	Drain Valve	30
General Repair Information	19	Complete Sprayer Parts	32
Motor Test	20	Technical Data	31
Motor Brushes	21	Dimensions	31
Displacement Pump	22	Accessories	31
Motor	23	Sherwin-Williams Warranty	36
Motor Control Board	24	Phone Number	36

Symbols

Warning Symbol



WARNING

This symbol alerts you to the possibility of serious injury or death if you do not follow the instructions.

Caution Symbol



CAUTION

This symbol alerts you to the possibility of damage to or destruction of equipment if you do not follow the instructions.

WARNING



INSTRUCTIONS

EQUIPMENT MISUSE HAZARD

Equipment misuse can cause the equipment to rupture or malfunction and result in serious injury.

- This equipment is for professional use only.
- Read all instruction manuals, tags, and labels before operating the equipment.
- Use the equipment only for its intended purpose. If you are not sure, call your distributor.
- Do not alter or modify this equipment. Use only genuine Graco parts.
- Check equipment daily. Repair or replace worn or damaged parts immediately.
- Do not exceed the maximum working pressure of the lowest rated system component. Refer to the **Technical Data** on page 31 for the maximum working pressure of this equipment.
- Use fluids and solvents which are compatible with the equipment wetted parts. Refer to the **Technical Data** section of all equipment manuals. Read the fluid and solvent manufacturer's warnings.
- Do not use 1,1,1-trichloroethane, methylene chloride, other halogenated hydrocarbon solvents or fluids containing such solvents in pressurized aluminum equipment. Such use could result in a chemical reaction, with the possibility of explosion.
- Do not use hoses to pull equipment.
- Route hoses away from traffic areas, sharp edges, moving parts, and hot surfaces. Do not expose Graco hoses to temperatures above 82°C (180°F) or below -40°C (-40°F).
- Do not lift pressurized equipment.
- Comply with all applicable local, state, and national fire, electrical, and safety regulations.

WARNING



INJECTION HAZARD

Spray from the gun, leaks or ruptured components can inject fluid into your body and cause extremely serious injury, including the need for amputation. Fluid splashed in the eyes or on the skin can also cause serious injury.

- Fluid injected into the skin is a serious injury. The injury may look like just a cut, but it is a serious injury. Get immediate medical attention.
- Do not point the gun at anyone or at any part of the body.
- Do not put your hand or fingers over the spray tip.
- Do not stop or deflect leaks with your hand, body, glove or rag.
- Do not “blow back” fluid; this is not an air spray system.
- Always have the tip guard and the trigger guard on the gun when spraying.
- Check the gun diffuser operation weekly. Refer to the gun manual.
- Be sure the gun trigger safety operates before spraying.
- Lock the gun trigger safety when you stop spraying.
- Follow the **Pressure Relief Procedure** on page 8 if the spray tip clogs and before cleaning, checking or servicing the equipment.
- Tighten all fluid connections before operating the equipment.
- Check the hoses, tubes, and couplings daily. Replace worn or damaged parts immediately. Do not repair high pressure couplings; you must replace the entire hose.
- Fluid hoses must have spring guards on both ends, to help protect them from rupture caused by kinks or bends near the couplings.



TOXIC FLUID HAZARD

Hazardous fluid or toxic fumes can cause serious injury or death if splashed in the eyes or on the skin, inhaled, or swallowed.

- Know the specific hazards of the fluid you are using.
- Store hazardous fluid in an approved container. Dispose of hazardous fluid according to all local, state and national guidelines.
- Always wear protective eyewear, gloves, clothing and respirator as recommended by the fluid and solvent manufacturer.

! WARNING



FIRE AND EXPLOSION HAZARD

Improper grounding, poor ventilation, open flames or sparks can cause a hazardous condition and result in a fire or explosion and serious injury.



- If there is any static sparking or you feel an electric shock while using this equipment, **stop spraying immediately**. Do not use the equipment until you identify and correct the problem.
- Provide fresh air ventilation to avoid the buildup of flammable fumes from solvents or the fluid being sprayed.
- Keep the spray area free of debris, including solvent, rags, and gasoline.
- Electrically disconnect all equipment in the spray area.
- Extinguish all open flames or pilot lights in the spray area.
- Do not smoke in the spray area.
- Do not turn on or off any light switch in the spray area while operating or if fumes are present.
- Do not operate a gasoline engine in the spray area.
- Use only with a grounded outlet that matches the grounded plug of this equipment.



MOVING PARTS HAZARD

Moving parts can pinch or amputate your fingers.

- Keep clear of all moving parts when starting or operating the pump.
- Before servicing the equipment, follow the **Pressure Relief Procedure** on page 8 to prevent the equipment from starting unexpectedly.

NOTE: This is an example of the DANGER label on your sprayer. This label is available in other languages, free of charge. See page 31 to order.

! DANGER !			
	FIRE AND EXPLOSION HAZARD		SKIN INJECTION HAZARD
<p>Spray painting, flushing or cleaning equipment with flammable liquids in confined areas can result in fire or explosion.</p> <p>Use outdoors or in extremely well ventilated areas. Ground equipment, hoses, containers and objects being sprayed.</p> <p>Avoid all ignition sources such as static electricity from plastic drop cloths, open flames such as pilot lights, hot objects such as cigarettes, arcs from connecting or disconnecting power cords or turning light switches on and off.</p> <p>Failure to follow this warning can result in death or serious injury.</p>	<p>Liquids can be injected into the body by high pressure airless spray or leaks – especially hose leaks.</p> <p>Keep body clear of the nozzle. Never stop leaks with any part of the body. Drain all pressure before removing parts. Avoid accidental triggering of gun by always setting safety latch when not spraying.</p> <p>Never spray without a tip guard.</p> <p>In case of accidental skin injection, seek immediate "Surgical Treatment".</p> <p>Failure to follow this warning can result in amputation or serious injury.</p>		
READ AND UNDERSTAND ALL LABELS AND INSTRUCTION MANUALS BEFORE USE			

Component Function and Identification

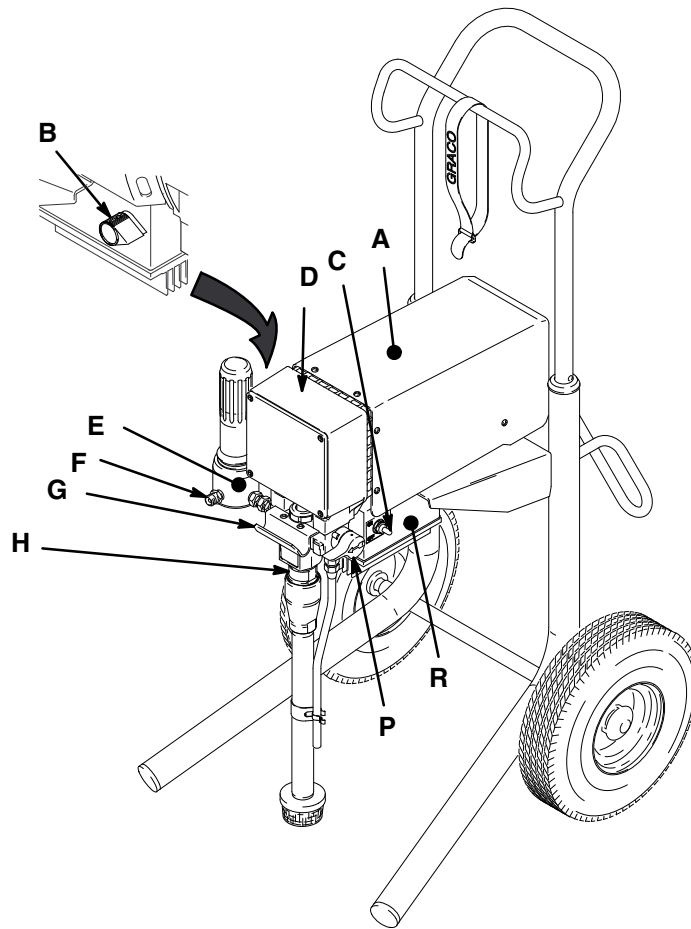

Fig. 1

7786A

A	Motor (Under shield shown)	DC motor, permanent magnet, totally enclosed, fan cooled
B	Pressure Adjusting Knob	Controls fluid outlet pressure
C	ON/OFF Switch	Power switch that controls 120 VAC main power to sprayer
D	Drive Assembly	Transfers power from DC motor to the displacement pump
E	Fluid Filter	Filter of fluid between source and spray gun
F	Fluid Outlet	Main hose to spray gun is connected here
G	Pail Hanger	Container for fluid to be sprayed may be hung here
H	Displacement Pump	Transfers fluid to be sprayed from source through spray gun
P	Pressure Drain Valve	Relieves fluid outlet pressure when open; diverts fluid to drain line
R	Pressure Control	Controls motor speed to maintain fluid outlet pressure at displacement pump outlet. Works with pressure adjusting knob.

Setup

⚠ WARNING

If you supply your own hoses and spray gun, be sure the hoses are electrically conductive, that the gun has a tip guard, and that each part is rated for at least *3000 psi (210 bar, 21 MPa) Working Pressure*. This is to reduce the risk of serious injury caused by static sparking, fluid injection or over-pressurization and rupture of the hose or gun.

⚠ CAUTION

To avoid damaging the pressure control, which may result in poor equipment performance and component damage, follow these precautions:

- Do not allow material to freeze in sprayer.
- Use nylon spray hose at least 50 ft (15 m) long.
- Do not use wire braid hose.
- Do not install shutoff device between sprayer and gun. See Fig. 2.

1. **Connect hose (B) and gun (C) and screw it onto outlet nipple (A).** *Don't use thread sealant, and don't install spray tip yet!*

- 1 Do not install any shutoff device here.
- 2 Fill full with TSL
- 3 Shown in closed, or spray position.

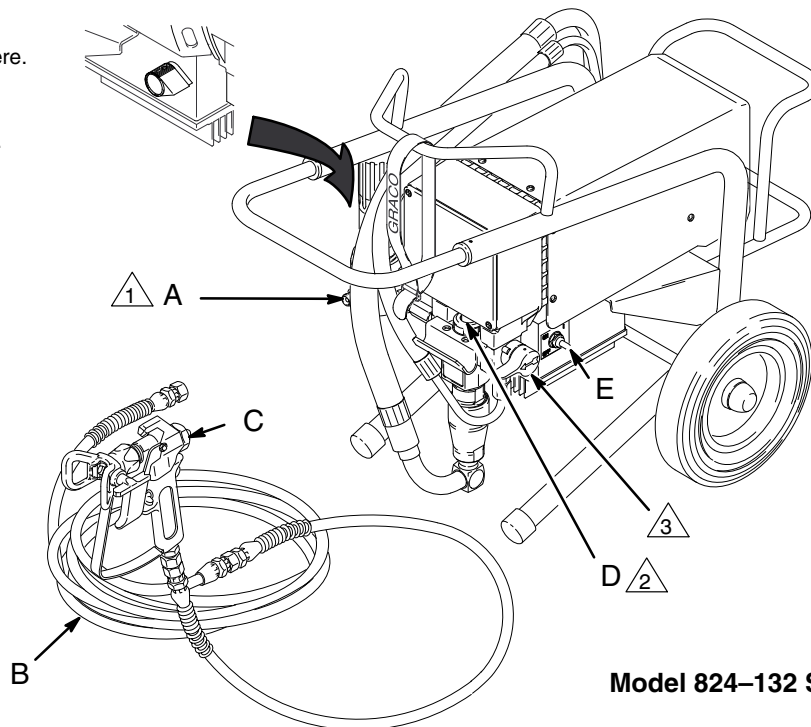

Model 824-132 Shown

2. **Fill packing nut (D).** Fill packing nut full with Graco Throat Seal Liquid (TSL) (64) supplied.

⚠ WARNING



FIRE AND EXPLOSION HAZARD
Proper electrical grounding is essential to reduce the risk of fire or explosion which can result in serious injury and property damage. Read **FIRE OR EXPLOSION HAZARD** on page 4 and **Grounding**, page 7.

3. **Plug in sprayer.** Be sure ON/OFF switch (E) is OFF. Plug cord into grounded outlet at least 20 ft (6 m) away from spray area.
4. **Flush pump** to remove oil installed to protect pump parts after factory testing. See page 12.
5. **Prepare paint** according to manufacturer's recommendations. Remove any paint skin. Stir paint to mix pigments. Strain paint through a fine nylon mesh bag (available at most paint dealers) to remove particles that could clog gun filter or spray tip. This is an important step toward trouble-free paint spraying.

continued on next page

Fig. 2

7787A

Setup

Grounding

⚠ WARNING

Improper installation or alteration of the grounding plug will result in a risk of electric shock, fire or explosion that could cause serious injury or death.

1. This equipment requires a 120 Vac, 60 Hz, 15A circuit with a grounding receptacle. See Fig. 3.

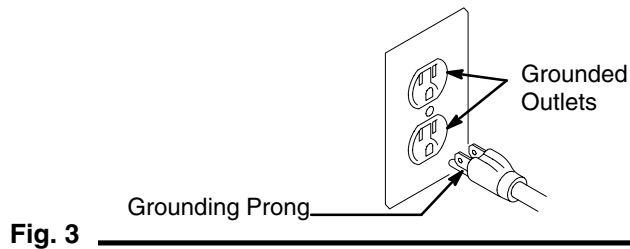

2. Do not alter the ground prong or use an adapter.
3. A 12 AWG, 3-wire, grounded 150 ft extension cord may be used with this equipment.

NOTE: Long extension cords affect sprayer performance.

How to use the gun safety latch

When engaged, the gun safety latch prevents the gun from accidental triggering. See Fig. 4.

⚠ WARNING

If the gun still sprays when the gun safety latch is engaged, adjust the gun. See manual 307–614, supplied.

How to use the pressure drain valve

Use the pressure drain valve to relieve fluid pressure from the pump and to help prime the pump. If the valve senses an over-pressure condition, it opens automatically to relieve fluid pressure. If this happens, stop spraying immediately, shut off and unplug the sprayer. Determine the cause of the problem and correct it before operating the sprayer again. Refer also to the Troubleshooting Guide, page 14. See Fig. 5.

How to use the pressure control

The pressure control controls the motor operation so the sprayer maintains constant fluid pressure at the pump outlet. Turn the pressure control knob fully counterclockwise to obtain the minimum setting. Turn the knob clockwise to increase pressure. See Fig. 6.

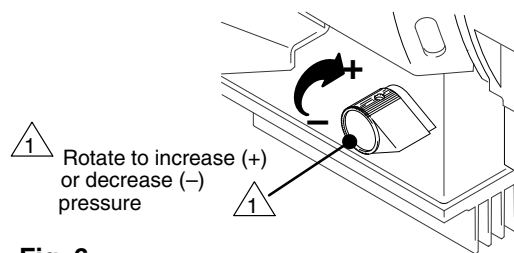
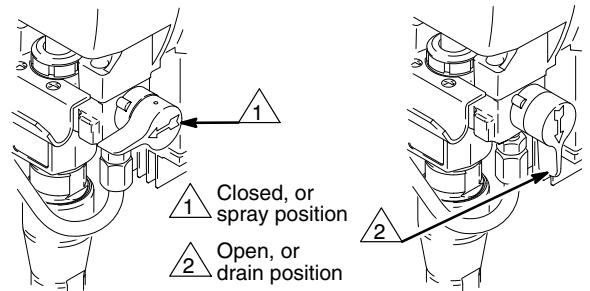
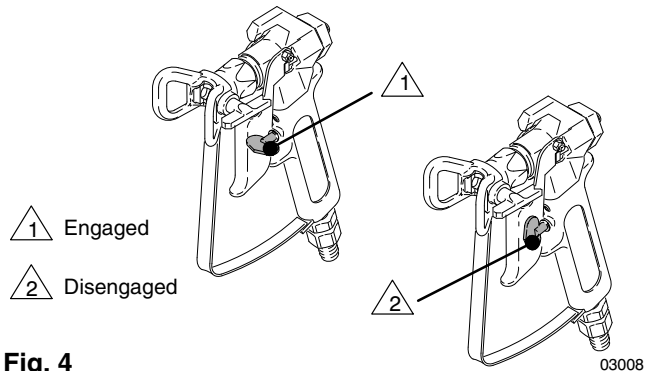

Setup

Pressure Relief Procedure

WARNING



INJECTION HAZARD

The system pressure must be manually relieved to prevent the system from starting or spraying accidentally. Fluid under high pressure can be injected through the skin and cause serious injury. To reduce the risk of an injury from injection, splashing fluid, or moving parts, follow the **Pressure Relief Procedure** whenever you:

- are instructed to relieve the pressure,
- stop spraying,
- check or service any of the system equipment,
- install or clean the spray tip.

1. Engage gun safety latch.
2. Turn ON/OFF switch to OFF.
3. Unplug power cord.
4. Disengage gun safety latch. Hold a metal part of gun against a grounded metal pail and trigger gun into pail to relieve pressure.
5. Engage gun safety latch.
6. Open any fluid drain valves in system. Leave drain valve open until you are ready to dispense again.

How to use the RAC IV tip guard

WARNING



INJECTION HAZARD

To reduce the risk of serious injury, when instructed to relieve pressure, follow the preceding **Pressure Relief Procedure**.

The tip guard alerts you to the risk of injection and helps prevent placing any part of the body close to the spray tip. The tip guard also adjusts the vertical or horizontal spray pattern. See page 10. The tip guard holds a reversing spray tip. The tip is in the spraying position when the tip handle points forward. See Fig. 7.

Clean front of tip frequently during day's operation. First, follow preceding **Pressure Relief Procedure**.

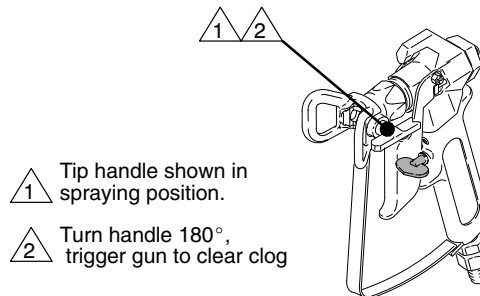

Fig. 7

03008

How to remove a tip clog

7. Release gun trigger. Engage safety latch. Rotate RAC IV tip handle 180°. See Fig. 7.
8. Disengage safety latch. Trigger gun into a pail or onto ground to remove clog.
9. Engage safety latch. Rotate tip handle to spraying position.
10. If tip is still clogged, engage safety latch, shut off and unplug sprayer, and open pressure drain valve to relieve pressure. Clean spray tip as shown in manual 308–644, supplied.

Startup

Use this procedure each time you start the sprayer to help ensure the sprayer is ready to operate and that you start it safely.

NOTE: If this is a first-time startup, flush the sprayer. See page 12.

1. **Open pressure drain valve (A).** See Fig. 8.
2. **Don't install spray tip until pump is primed!**
3. **Put suction hose or tube (C) into paint.** If you are pumping from a 1 gallon (5 liter) pail, push drain hose (D) down below top of pail to avoid splashing paint when drain valve is opened.

4. **Turn pressure knob (E) to minimum setting.**
5. **Disengage gun safety latch.** See Fig. 4.

CAUTION

To reduce the risk of damage to the displacement pump packings, never run the pump without fluid in it for more than 30 seconds.

6. **To prime pump,** turn sprayer ON/OFF switch (F) ON. Slowly increase pressure until sprayer starts. When fluid comes from pressure drain valve, close valve.

1 Shown in closed, or spray position.

2 Open, or drain position

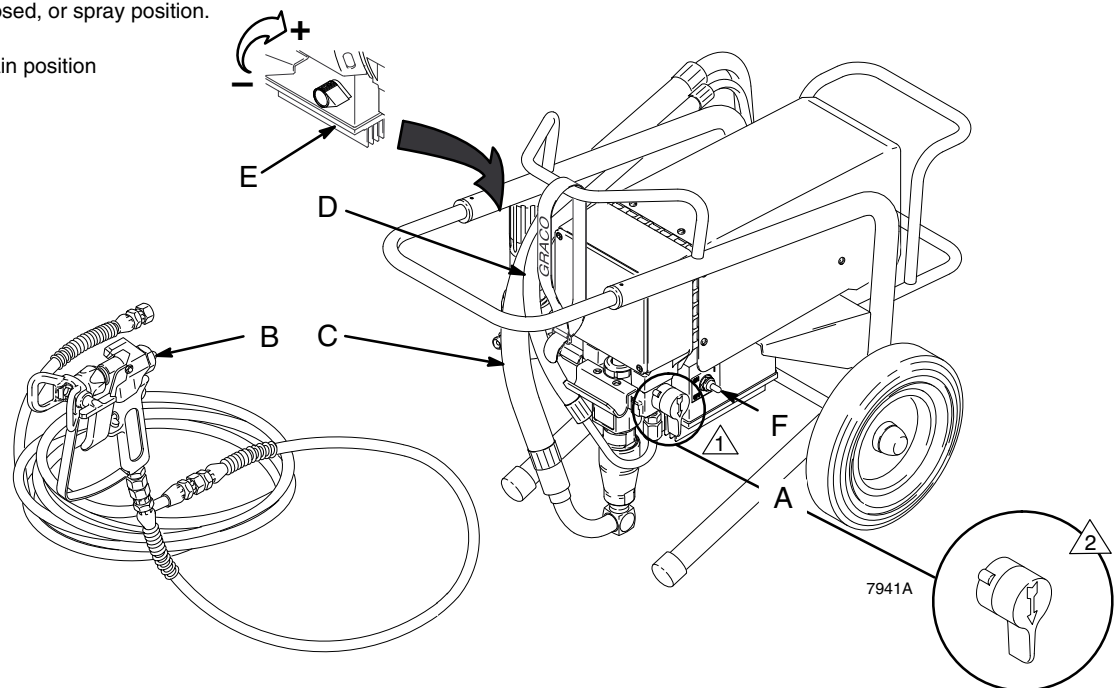

Fig. 8

Model 824-132 Shown

7787A

Startup

⚠ WARNING



FIRE AND EXPLOSION HAZARD

To reduce static sparking and splashing when priming, be sure the spray tip is not installed on the gun, and hold a metal part of the gun firmly to the side of a grounded metal pail.

7. **To prime hose**, lower pressure to reduce splashing. Holding gun against pail, trigger gun and slowly increase pressure until pump starts. Keep gun triggered until all air is forced out of system and fluid flows freely from gun. Release trigger and engage gun safety latch.
8. **Check all fluid connections for leaks.** Relieve pressure before tightening any connections.
9. **Install spray tip.** Engage gun safety latch first! See manual 308–644 for how to install tip.
10. **Adjust spray pattern**
 - a. Increase pressure just until spray from gun is completely atomized. To avoid excessive overspray and fogging, and to extend tip and sprayer life, always use lowest pressure needed to get desired results.
 - b. If more coverage is needed, use a larger tip rather than increasing pressure.
 - c. Test spray pattern. To adjust direction of spray pattern, engage gun safety latch and loosen retaining nut (B). Position tip guard horizontally for a horizontal pattern or vertically for a vertical pattern. Hold tip guard in place while tightening retaining nut. See Fig. 9.

NOTE: Spray patterns will change as tips wear. Change spray tip if adjusting pressure will not improve spray pattern.

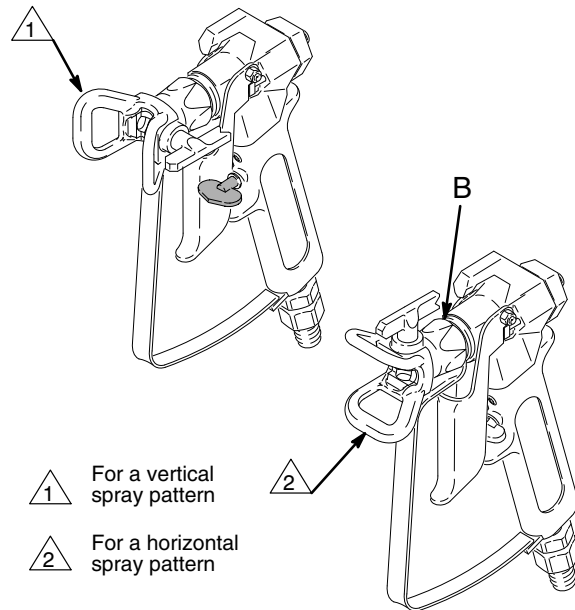

Fig. 9

03008

Shutdown and Care

WARNING



INJECTION HAZARD

To reduce the risk of serious injury, when instructed to relieve pressure, follow the **Pressure Relief Procedure** on page 8.

1. **Relieve pressure.**
2. **Check packing nut daily.** Keep packing nut full of TSL at all times to help prevent fluid buildup on piston rod and premature wear of packings.
3. **If pump begins to leak,** loosen packing nut and remove throat nut spacer (228). Tighten packing nut just snug. Over tightening causes binding and excessive packing wear. Use a round punch or brass rod and light hammer to adjust nut. Refer to Fig. 10. When leakage occurs again, repack pump.
4. **Clean gun's fluid filter often** and whenever gun is stored. Relieve pressure first. Refer to manual 307-614.
5. **Lubricate bearing housing** after every 100 hours of operation. Remove front cover. Apply several drops of SAE 10 non-detergent oil in bearing housing cavity (B). See Fig. 10.

CAUTION

To prevent pump corrosion, and to reduce the chance of fluid freezing in the pump in cold weather, never leave water or any type of paint in the sprayer when it is not in use. Freezing can seriously damage the sprayer or result in a loss of pressure or stalling.

6. **Flush sprayer at end of each work day** and fill it with mineral spirits to help prevent pump corrosion and freezing. See page 12.
7. **For very short shutoff periods,** leave suction hose in paint, relieve pressure, and clean spray tip.

WARNING



INJECTION HAZARD

See the warning section **INJECTION HAZARD** on page 3 for information on the hazard of using damaged hoses.

8. **Coil hose** when storing it, even for overnight, to help protect hose from kinking, abrasion, coupling damage, etc.

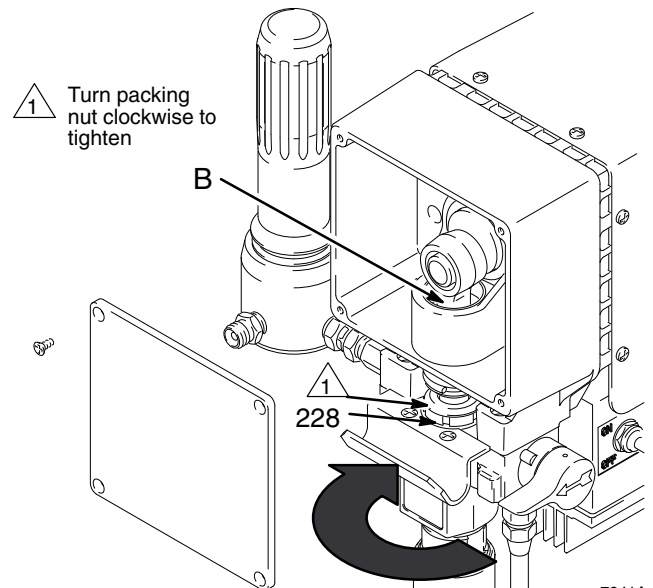

Fig. 10

7841A

Flushing

When to flush

Determine material to spray from column 1. Flush with material in column 2. Then follow recommendations in one of next three columns.

⚠ CAUTION

Do not leave water or water-based fluids in sprayer if it could freeze. Flush water out with mineral spirits. Frozen fluid in sprayer prevents starting and may cause serious damage.

If you are going to: ▼	Flush with: ▼	Prime with: ▼	Clean with: ▼	Store unit with: ▼
Spray latex paint	Warm, soapy water, then clean water	Latex-base paint	Warm soapy water, then clean water	Mineral spirits
Spray oil paint	Mineral spirits	Oil-base paint	Mineral spirits	Mineral spirits
Change latex to oil paint	Warm, soapy water, then clean water	Mineral spirits	Mineral spirits	Mineral spirits
Change oil to latex paint	Mineral spirits, soapy water, and clean water.	Latex	Warm, soapy water, then clean water	Mineral spirits
Change colors, same base	Compatible solvent such as water or mineral spirits			

How to flush

⚠ WARNING



INJECTION HAZARD

To reduce the risk of serious injury, when instructed to relieve pressure, follow the **Pressure Relief Procedure** on page 8.

1. **Relieve pressure.**
2. Remove spray tip and clean it separately. If you are changing from water-based to oil-based paints or solvents, be sure that tip is cleaned thoroughly.
3. Remove filter screen and then reinstall bowl, hand tight, without screen. Clean screen separately. See manual 308–249.
4. Pour one-half gallon (2 liters) of compatible solvent into a grounded metal flushing pail. Put suction hose in pail.
5. Open pressure drain valve. See Fig.11.
6. **To save paint still in pump and hose**, follow Step 7, except put drain hose in paint pail. When solvent appears, close drain valve. Put drain hose in flushing pail. Trigger gun into paint pail. When solvent appears, release trigger. Continue with Step 7.

Flushing

WARNING



FIRE AND EXPLOSION HAZARD

To reduce static sparking and splashing, always remove the spray tip from the gun, and hold a metal part of the gun firmly to the side of a grounded metal pail when flushing.

7. Lower pressure setting. Turn on sprayer. Maintaining metal-to-metal contact, trigger gun into flushing pail. Slowly increase sprayer pressure just until pump starts. Keep gun triggered until solvent flows freely from gun. Circulate solvent to thoroughly clean sprayer. Release gun trigger. Engage gun safety latch.
8. Open drain valve and circulate solvent through drain hose to thoroughly clean it. Close drain valve.
9. Remove suction hose from pail. Disengage gun safety latch. Trigger gun and run pump a few seconds to push air into hose. Do not run pump dry for more than 30 seconds to avoid damaging pump packings! Relieve pressure.

10. Reinstall clean filter screen.
11. Remove and clean inlet strainer. Wipe paint off suction hose and drain hose.
12. Leave drain valve open until you use sprayer again.

 Open or drain position

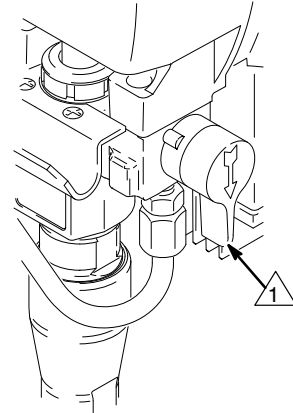

Fig. 11

7731A

Troubleshooting

⚠ WARNING



INJECTION HAZARD

To reduce the risk of serious injury, when instructed to relieve pressure, follow the **Pressure Relief Procedure** on page 8.

⚠ CAUTION

Thaw sprayer if water or water-based paint has frozen in it, due to exposure to low temperatures, by placing it in a warm area. Do not try to start sprayer until it has thawed completely or damage to motor and/or control board may occur. If paint hardened (dried) in sprayer, the pump packings and/or pressure transducer must be replaced. See page 22 (pump) or 28 (pressure transducer).

Check everything in the troubleshooting tables before disassembling the sprayer.

Basic Problem Solving

TYPE OF PROBLEM	WHAT TO CHECK <i>If check is OK, go to next check</i>	WHAT TO DO <i>When check is not OK, refer to this column</i>
Fluid Pressure	1. Check pressure transducer knob setting. The pump won't develop much pressure if it is at minimum setting (fully counterclockwise).	1. Slowly increase pressure setting to see if motor starts.
	2. Check for a clogged spray tip or fluid filter, if used. See page 8.	2. If tip is still clogged, relieve pressure; refer to separate gun or tip instruction manual for tip cleaning. Clean or replace filter element. See manual 308–249.
Mechanical	1. Check for frozen or hardened paint in pump (18). Using a screwdriver, carefully try to rotate fan at back of motor by hand. See page 23.	1. Thaw. After thawing, plug in sprayer and turn it on. Slowly increase pressure setting to see if motor starts. If it doesn't start, see CAUTION above.
	2. Check pump connecting rod pin (14). It must be completely pushed into connecting rod (12), and retaining spring (15) must be firmly in connecting rod groove. See Fig. 18, page 22.	2. Push pin into place and secure with spring retainer.
	3. Check for motor damage. Remove drive housing assembly (2). See page 26. Try to rotate motor fan by hand.	3. Replace motor (85) if fan won't turn. See page 23.
Electrical	1. Check electrical supply with volt meter. Meter should read 105–125 VAC.	1. Reset building circuit breaker; replace building fuse. Try another outlet.
	2. Check extension cord for visible damage. Use a voltmeter or test lamp at extension cord outlet to check.	2. Replace extension cord.
	3. Check sprayer power supply cord (30) for visible damage such as broken insulation or wires.	3. Replace power supply cord. See page 25.

Basic Problem Solving

TYPE OF PROBLEM	WHAT TO CHECK <i>If check is OK, go to next check</i>	WHAT TO DO <i>When check is not OK, refer to this column</i>
Electrical <i>(continued)</i>	<p>4. Check motor brushes for the following:</p> <ul style="list-style-type: none"> a. Loose terminal screws. b. Broken or misaligned brush springs. c. Brushes binding in holders. d. Broken leads. e. Worn brushes. f. Brush leads snagged on spring clip. <p>NOTE: The brushes do not wear at same rate on both sides of motor. Check both brushes.</p>	<p>4. Refer to page 21.</p> <ul style="list-style-type: none"> a. Tighten. b. Replace broken spring and/or align spring with brush c. Clean brush holders. Remove carbon with small cleaning brush. Align brush leads with slot in brush holder to assure free vertical brush movement. d. Replace brushes e. Replace brushes if less than 0.5 in. (12.5 mm) long. f. Correctly route the wires. See page 21.
	<p>5. Check motor armature commutator for burn spots, gouges and extreme roughness. Remove motor cover and brush inspection plates to check. See page 21.</p>	<p>5. Remove motor and have motor shop resurface commutator if possible. See page 23.</p>
	<p>6. Check motor armature for shorts using armature tester (growler) or perform motor test. See page 20.</p>	<p>6. Replace motor. See page 23.</p>
	<p>7. Check leads from pressure transducer and motor to motor control board (22a) to be sure they are securely fastened and properly mated.</p>	<p>7. Replace loose terminals; crimp to leads. Be sure male terminal blades are straight and firmly connected to mating part.</p>
	<p>8. Check motor control board (22a) by performing motor control board diagnostics on page 24. If diagnostics indicate, substitute with a good board.</p> <p>CAUTION: Do not perform this check until motor armature is determined to be good. A bad motor armature can burn out a good board.</p>	<p>8. Replace board. See page 24.</p>
	<p>9. Check power supply cord (30). Disconnect black and white power cord terminals; connect volt meter to these leads. Plug in sprayer. Meter should read 105–125 VAC. Unplug sprayer.</p>	<p>9. Replace power supply cord. See page 25.</p>
	<p>10. Check ON/OFF switch (80). Disconnect black wire (96) between motor control board (22a) and switch and connect volt meter between exposed terminal switch and power cord's white wire. Plug in sprayer and turn ON. Meter should read 105–125 VAC. Turn off and unplug sprayer.</p>	<p>10. Replace ON/OFF switch. See page 25.</p>
	<p>11. Check motor thermal cutout switch. Connect ohm-meter between motor's red leads. Meter should read 1 ohm maximum.</p>	<p>11. Allow motor to cool. Correct cause of overheating. If switch remains open after motor cools, replace motor.</p>
	<p>12. Check the transducer (67) by replacing it with a new one.</p>	<p>12. Replace pressure transducer. See page 28.</p>
	<p>13. Check pressure adjustment potentiometer (77) by replacing it with a new one.</p>	<p>13. Replace potentiometer.</p>

Intermediate Problem Solving

TYPE OF PROBLEM	WHAT TO CHECK <i>If check is OK, go to next check</i>	WHAT TO DO <i>When check is not OK refer to this column</i>
Low Output	1. Check for worn spray tip.	1. Follow Pressure Relief Procedure Warning on page 8, then replace tip. See your separate gun or tip manual.
	2. Be sure pump does not continue to stroke when gun trigger is released. Plug in and turn on sprayer. Prime with paint. Trigger gun momentarily, then release and engage safety latch. Relieve pressure, turn off and unplug sprayer.	2. Service pump. See page 22.
	3. Release gun trigger. Observe resting position of pump rod (222).	3. If pump consistently comes to rest with rod (222) fully extended, the piston packings and/or piston valve may be worn. Service the pump. See page 22.
	4. Check electrical supply with volt meter. Meter should read 105–125 VAC.	4. Reset building circuit breaker; replace building fuse. Repair electrical outlet or try another outlet.
	5. Check extension cord size and length.	5. Replace with a correct, grounded extension cord. Note that long lengths and/or smaller gauges reduce performance.
	6. Check motor brushes. See Electrical – What To Check, item 4, on page 15.	6. See page 21.

Intermediate Problem Solving

TYPE OF PROBLEM	WHAT TO CHECK <i>If check is OK, go to next check</i>	WHAT TO DO <i>When check is not OK, refer to this column</i>
Low Output <i>(continued)</i>	7. Check motor control board (22a) by substituting with a good board. CAUTION: Do not perform this check until motor armature is determined to be good. A bad motor armature can burn out a good board.	7. Replace board. See page 24.
	8. Check motor armature for shorts by using an armature tester (growler) or perform motor test. See page 20.	8. Replace motor. See page 23
Drain Valve Leaks	1. Check drain valve for correct torque and/or worn parts. Check for debris trapped on seat.	1. Tighten to 185 in-lb (21 N·m). Clean valve and replace with new gasket (55) and sealant 110–110. See page 30.
No Output: Motor Runs And Pump Strokes	1. Check paint supply.	1. Refill and reprime pump.
	2. Check for clogged intake strainer.	2. Remove and clean, then reinstall.
	3. Check for loose suction tube or fittings. See page 29.	3. Tighten; use thread sealant on npt threads of suction tube (43). Check for damaged o-ring (45).
	4. Check to see if intake valve ball and piston ball are seating properly. See page 22.	4. Remove intake valve and clean. Check ball and seat for nicks; replace as needed. See page 22. Strain paint before using to remove particles that could clog pump.
	5. Check for leaking around throat packing nut which may indicate worn or damaged packings. See page 22.	5. Replace packings. See page 22. Also check piston valve seat for hardened paint or nicks and replace if necessary. Tighten packing nut/wet-cup.
	6. Release gun trigger. Observe resting position of pump rod (222).	6. If pump consistently comes to rest with rod (222) fully extended, the piston packings and/or piston valve may be worn. Service the pump. See page 22.
No Output: Motor Runs But Pump Does Not Stroke	1. Check displacement pump connecting rod pin (14). See Fig. 18, page 22.	1. Replace pin if missing. Be sure retainer spring (15) is fully in groove all around connecting rod.
	2. Check connecting rod assembly (12) for damage. See page 26.	2. Replace connecting rod assembly. See page 26.
	3. Be sure crank in drive housing rotates; plug in sprayer and turn on briefly to check. Turn off and unplug sprayer. See page 26.	3. Check drive housing assembly for damage and replace if necessary. See page 26.
Spray Pattern Variations	1. Spray tip worn beyond sprayer pressure capability.	1. Replace spray tip. NOTE: A smaller size tip will provide longer life.
	2. Check motor control board (22a) by performing motor control board diagnostics on page 24. If diagnostics indicate, substitute with a good board. CAUTION: Do not perform this check until motor armature is determined to be good. A bad motor armature can burn out a good board.	2. Replace board. See page 24.

Intermediate Problem Solving

TYPE OF PROBLEM	WHAT TO CHECK <i>If check is OK, go to next check</i>	WHAT TO DO <i>When check is not OK, refer to this column</i>
Spray Pattern Variations <i>(continued)</i>	3. Check pressure adjustment potentiometer (77) by replacing it with a new one.	
	4. Check Low Output section, page 16.	
Motor Is Hot and Runs Intermittently	1. Determine if sprayer was operated at high pressure with small tips, which causes excessive heat build up.	1. Decrease pressure setting or increase tip size.
	2. Be sure ambient temperature where sprayer is located is no more than 90°F (32°C) and sprayer is not located in direct sun.	2. Move sprayer to shaded, cooler area if possible.
	3. Check motor.	3. Replace motor. See page 23.
Building Circuit Breaker Opens As Soon As Sprayer Switch Is Turned On.	1. Check all electrical wiring for damaged insulation, and all terminals for loose fit or damage. Also check wires between pressure transducer and motor. See page 23.	1. Repair or replace any damaged wiring or terminals. Securely reconnect all wires.
	2. Check for missing motor brush inspection plate gasket (see page 21), bent terminal forks or other metal to metal contact points which could cause a short.	2. Correct faulty conditions.
	3. Check motor armature for shorts. Use an armature tester (growler) or perform motor test. See page 18. Inspect windings for burns.	3. Replace motor. See page 23.
	4. Check motor control board (22a) by performing motor control board diagnostics on page 24. If diagnostics indicate, substitute with a good board. CAUTION: Do not perform this check until motor armature is determined to be good. A bad motor armature can burn out a good board	4. Replace board. See page 24.
Circuit breaker opens after sprayer operates for 5 to 10 minutes.	1. Check 'Basic Problems – Electrical' on page 14.	
Building circuit breaker opens as soon as sprayer is plugged into outlet and sprayer is NOT turned on.	1. Check ON/OFF switch (80). Be sure sprayer is unplugged! Disconnect wires from switch. Check switch with ohmmeter. The reading should be infinity with ON/OFF switch OFF, and zero with switch ON. CAUTION: A short in motor circuit can damage switch and or motor control board (22a).	1. Replace ON/OFF switch. See page 25.
	2. Check for damaged or pinched wires in junction box (20).	2. Replace damaged parts.
Unit will not run on generator but does run on AC power	1. Check the generator's "peak" voltage. This sprayer will not run if the peak voltage is above 190V or below 100V.	1. Use AC power or a different generator.

General Repair Information

WARNING



INJECTION HAZARD

To reduce the risk of serious injury, when instructed to relieve pressure, follow the **Pressure Relief Procedure** on page 8.

Tool List

These service tools are required.

12" adjustable wrench: *pump*
1/4" Allen® wrench: *filter plug*
3/8" Allen® wrench: *pump manifold*
3/16" Allen® wrench: *gear housing, legs, handle*
5/64" Allen® wrench: *pressure adjustment knob*
Phillips® screwdriver: *junction box, front cover, motor shield*
3/8" socket wrench: *motor mount*
5/8" socket wrench: *drain valve, on/off switch boot, piston*
5/8" open end wrench: *outlet fittings*
13/16" socket wrench: *drain valve*
1-1/4" socket wrench: *pump inlet valve*
1/2" open end wrench: *pump rod*
11/16" open end wrench: *piston jam nut*
15/16" open end wrench: *flats of inlet tube*
1-3/4" open end wrench: *pump jam nut*
5/64" drive pin: *drain valve pin*
3" needle nose pliers: *wiring, on/off switch*
Hammer & punch: *packing nut*
Torque wrenches: *various fasteners*
Pipe wrench: *suction tube*

CAUTION

To reduce the risk of a pressure transducer malfunction, properly mate connectors and never pull on a wire to disconnect it.

1. **When disconnecting wires**, use needle nose pliers to separate mating connectors.
2. **When reconnecting wires**, center flat blade of male connector in blade of female connector.

3. **Route wires carefully** and avoid pinching any wires between covers.

CAUTION

Improper wire routing can result in poor sprayer performance or damage to the pressure transducer.

4. **Keep all screws, nuts, washers, gaskets, and electrical fittings** removed during repair procedures.
5. **Test your repair before regular operation** to be sure problem is corrected.
6. **If sprayer does not operate properly**, verify that everything was done correctly. Also refer to Troubleshooting Guide, page 14, to help identify other possible problems and solutions.

WARNING



MOVING PARTS HAZARD

To reduce the risk of serious injury, including electric shock, **DO NOT** touch any moving parts or electrical parts with your fingers or a tool while inspecting the sprayer.

Shut off the sprayer and unplug it as soon as you complete the inspection.

Reinstall all covers, gaskets, screws and washers before operating the sprayer.

WARNING



FIRE HAZARD

During operation, the motor and drive housing become very hot and could burn your skin if touched. Flammable materials spilled on the hot, bare motor could cause a fire or explosion.

Motor Test

⚠ WARNING



INJECTION HAZARD

To reduce the risk of serious injury, when instructed to relieve pressure, follow the **Pressure Relief Procedure** on page 8.

For checking armature, motor winding and brush electrical continuity.

Setup

1. Unplug sprayer.
2. Remove drive housing. See page 26. This is to ensure that any resistance you notice in armature test is due to motor and not to worn gears in drive housing.
3. Remove motor brush inspection covers (A). See Fig. 12.
4. Remove screws (25, 26). Lower control board (22a). Disconnect two leads (C) from motor to board. See Fig. 13.

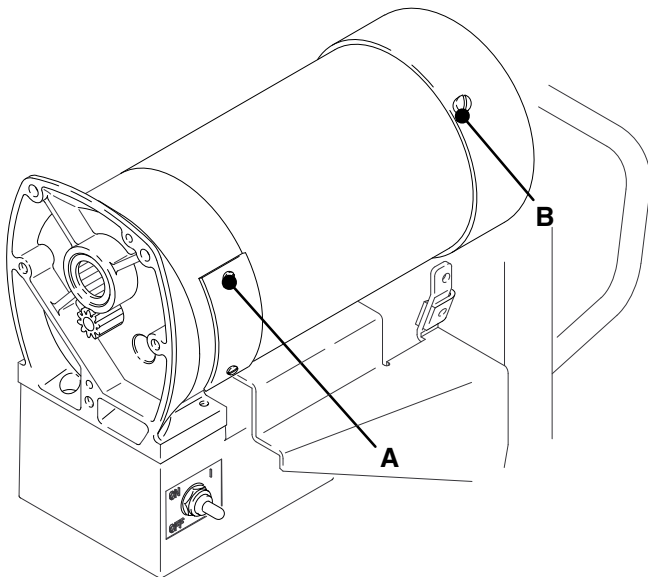

Fig. 12

02991

Armature Short Circuit Test

1. Remove fan cover (B). See Fig. 12.
2. Spin motor fan by hand. If there are no shorts, the motor will coast two or three revolutions before coming to a complete stop. If the motor does not spin freely, the armature is shorted and the motor must be replaced. See page 23.

Armature, Brushes, and Motor Wiring Open Circuit Test (Continuity)

1. Connect red and black motor leads (C) together with a test lead. Turn motor fan by hand at about two revolutions per second. See Fig. 13.

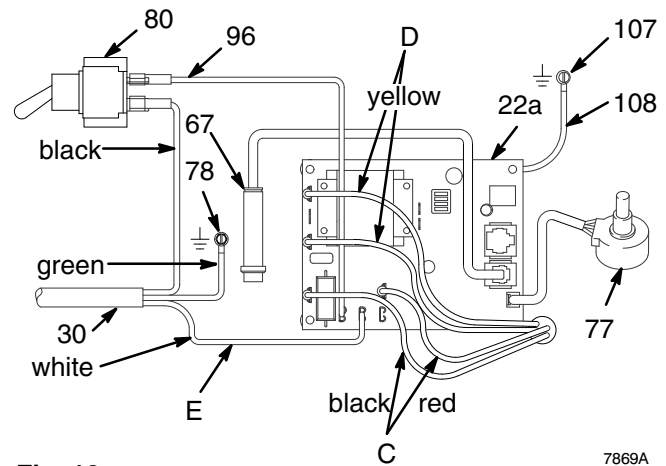

Fig. 13

7869A

2. When turning the fan on a DC motor, normally you sense an even, pulsing resistance. If there is irregular turning resistance, or no turning resistance, check and repair the following as needed: broken brush springs, brush leads, motor leads; loose brush terminal screws or motor lead terminals; worn brushes. See page 21.
3. If there is still uneven or no turning resistance, replace motor. See page 23.

Motor Brushes

NOTE: Replace brushes when worn to about 12.5 mm (0.5 in.). Always check both brushes. Brush Repair Kit 236–967 is available for motor brush repair.

NOTE: Replacement brushes may last only half as long as the original ones. To maximize brush life, break in new brushes by operating the sprayer with no load as instructed in this procedure.

NOTE: To minimize down time, and for best sprayer performance, check motor brushes and clean transducer (see page 28) whenever pump is repacked.

⚠ WARNING



INJECTION HAZARD
To reduce the risk of serious injury, when instructed to relieve pressure, follow the **Pressure Relief Procedure** on page 8.

1. Unplug sprayer.
2. Remove both inspection covers (A) and their gaskets. See Fig.14.

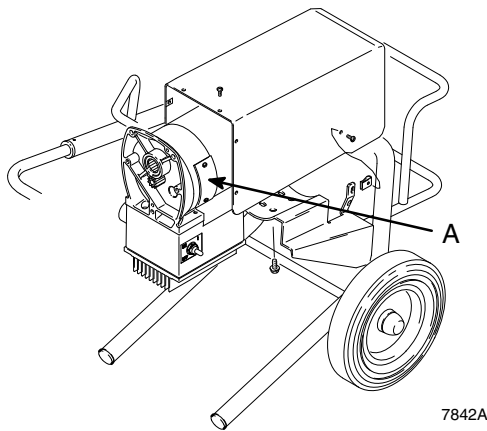



Fig. 14

3. Push in spring clip (F) and release hooks (G) from brush holder (B). Pull out spring clip. See Fig. 15.
4. Inspect commutator for excessive pitting, burning or gouging. A black color on commutator is normal. Have commutator resurfaced by a qualified motor repair shop if brushes seem to wear too fast or arc excessively. See Step 9.d., also.
5. Repeat for other side.
6. Place a new brush (C) in holder (B) so ramp (H) faces spring. See Fig. 15.
7. Holding spring clip (F) at a slight angle, slide spring clip into brush holder and hook it over end of holder. See Fig. 16. Pull on spring clip to be sure it stays in place. Connect brush lead to blade connector (E).

8. Repeat for other side.
9. **Test brushes.**
 - a. Remove pump connecting rod pin (14).

⚠ WARNING



ELECTRIC SHOCK HAZARD
Do not touch the brushes, leads, springs or brush holders while the sprayer is plugged in to reduce the risk of electric shock and serious bodily injury.

- b. With sprayer OFF, turn pressure control knob fully counterclockwise to minimum pressure. Plug in sprayer.
 - c. Turn sprayer ON. Slowly increase pressure until motor is at full speed.
 - d. Inspect brush and commutator contact area for excessive arcing. Arcs should not trail or circle around commutator surface.
10. Install brush inspection covers and gaskets.
11. **Break in brushes.** Operate sprayer for at least one hour with no load. Install pump connecting rod pin.

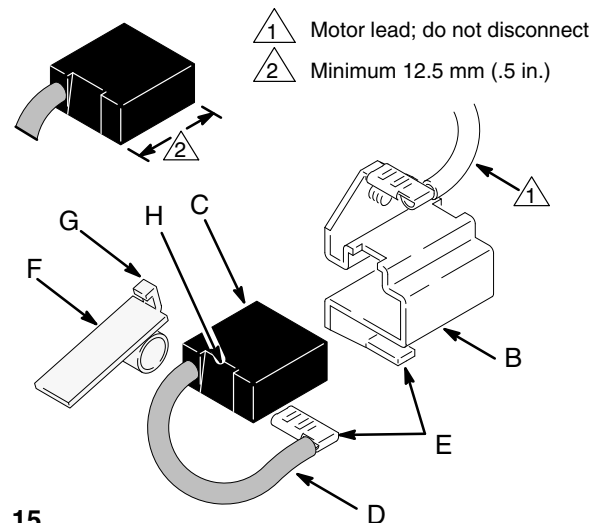

Fig. 15

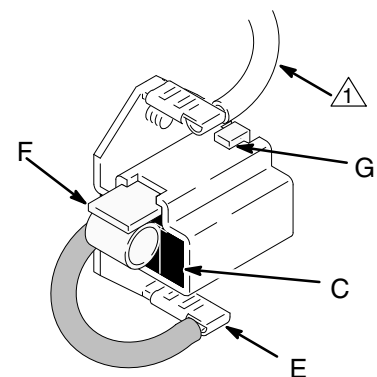

Fig. 16

03881

Displacement Pump

NOTE: Packing Repair Kit 235–703 is available. Reference numbers of parts included in the kit are marked with an asterisk, i.e., (223*).

Removing pump (See Fig.17)

⚠ WARNING

INJECTION HAZARD
To reduce the risk of serious injury, when instructed to relieve pressure, follow **Pressure Relief Procedure** on page 8.

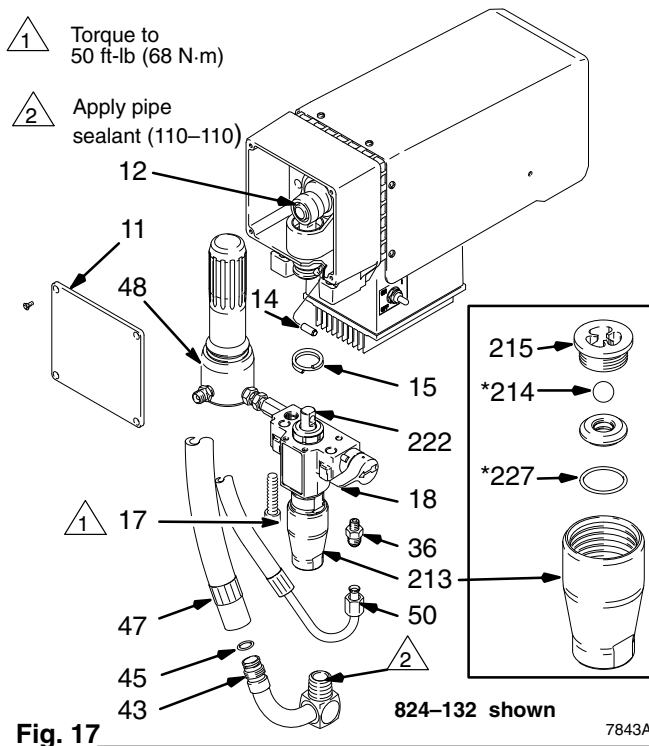

Fig. 17

1. **Relieve pressure.**
2. Flush pump, if possible. Relieve pressure. Stop pump with piston rod (222) in its lowest position, if possible. To lower piston rod manually, rotate motor fan blades.
3. Remove filter (48).
4. **Model 824–132.** While pulling upward on suction hose (47), unscrew hose from inlet tube (43). Unscrew drain hose (50) from displacement pump nipple (36).
5. **Model 824–130.** Remove suction tube (43). Unscrew drain tube (84) from displacement pump nipple (36).

6. Use a screwdriver to push retaining spring (15) up and push out pin (14).
7. Loosen screws (17). Remove pump (18).

Repairing pump

See manual 308–815 for displacement pump repair instructions and parts.

Installing pump (See Fig. 17 and 18)

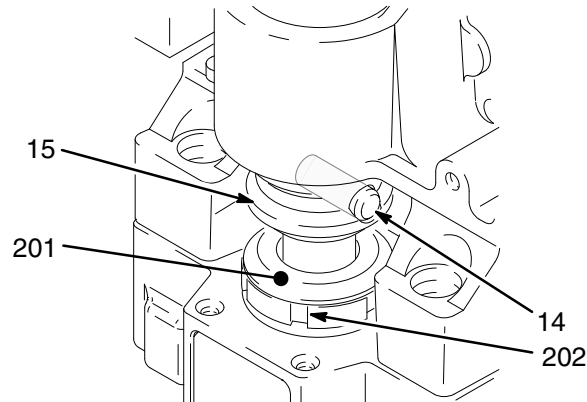

Fig. 18

7840A

1. Lightly grease or oil transducer (67). See Fig. 24. Guide pump over alignment pins and pressure transducer. Tap it into position with a soft hammer. Tighten screws (17) to 50 ft-lb (68 N·m).
2. Align hole in rod (222) with connecting rod assembly (12). Use screwdriver to push retaining spring (15) up and push in pin (14). Push retaining spring into place around connecting rod.

⚠ WARNING

MOVING PARTS HAZARD
Be sure retaining spring (18) is firmly in groove all around, to prevent pin (14) from working loose. See Fig. 18.

If pin works loose, parts (including pump connecting rod or bearing housing) could project into the air and cause serious injury or property damage.

3. Replace o-ring (45) if worn or damaged. See page 29. Reconnect suction and drain hoses (47, 50). Install front cover (11).
4. Tighten packing nut (202) enough to stop leakage, but no tighter. Fill packing nut full with Graco TSL. Push plug (201) into packing nut.

Motor

⚠ **WARNING**



INJECTION HAZARD
To reduce the risk of serious injury, when instructed to relieve pressure, follow the **Pressure Relief Procedure** on page 8.

NOTE: See Fig. 21 except where noted.

1. Try to stop pump with piston rod (222) in lowest position. To lower piston rod manually, remove motor shield (32) and rotate motor fan blades. Use a screwdriver to push retaining spring (15) up and push out pin (14). See Fig. 19.
2. **Relieve pressure.**
3. Remove motor shield (32).
4. Lift connecting rod. Remove screws (25, 26) and lower heat sink (22) and motor control board (22a). Disconnect motor wires and pressure transducer wire (A) from motor control board. Remove heat sink (22) and motor control board (22a), screws (23), and junction box (20). Refer to Fig. 21 and 13.
5. Remove drive housing cover (11).
6. Turn displacement pump rod (222) so pin hole aligns with bottom drive housing screw (16). See Fig. 20. Remove three drive housing screws and lockwashers (16, 4). See Fig. 20 and 21.
7. Remove two motor screws and lockwashers (3, 4).
8. Tap lower rear of drive housing (2) with a plastic mallet to loosen motor. Pull drive housing straight off motor while guiding pressure transducer wire (A) from motor. Do not allow gear (13) to fall. Read **CAUTION** on page 26.

9. Remove four screws (75) and lift motor off cart (70).
10. Align new motor with cart and reinstall screws (75).
11. Assemble drive housing to motor. Follow steps 9 to 15 on page 26. Install junction box.
12. Connect wires to motor control board (22a). Refer to Fig. 13. Install motor control board.
13. Connect piston rod (222) to drive housing; see page 22, **Installing Pump**, Step 2 and **WARNING** following it.
14. Install motor shield (32) and drive housing cover (11).

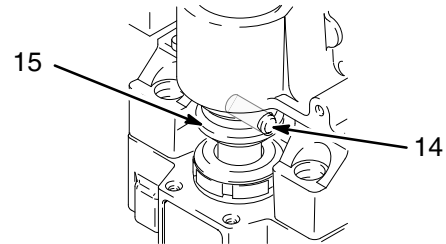

Fig. 19

7840A

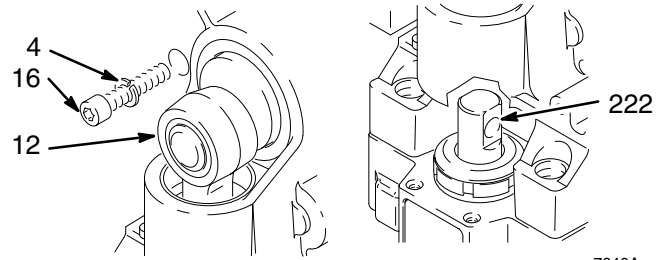
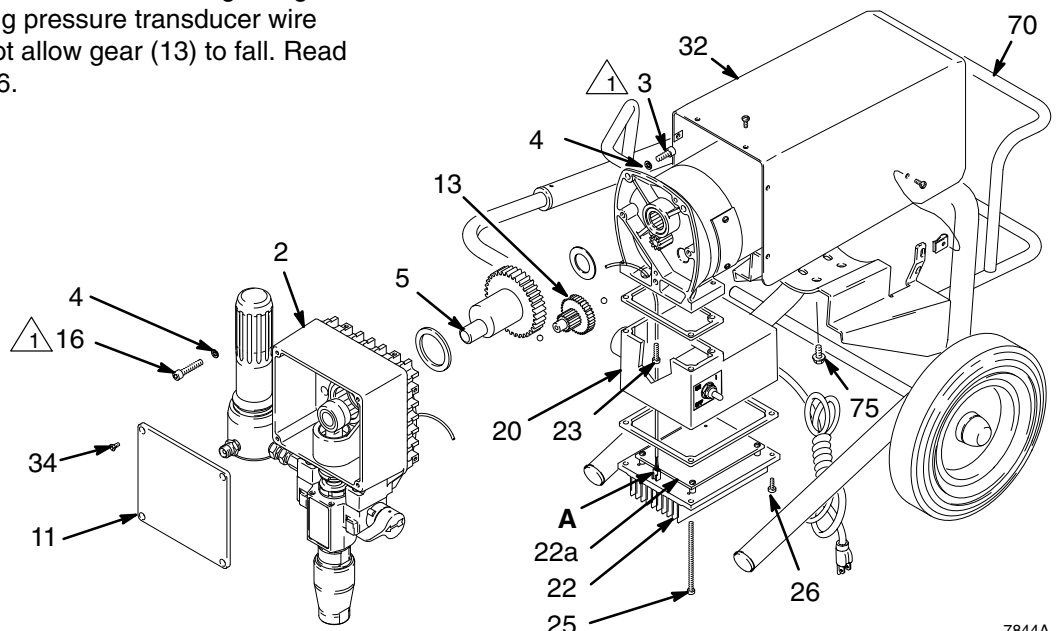

Fig. 20

7840A



1 Torque to 80 in-lb (9 N·m)

Fig. 21

7844A

Motor Control Board

Motor control board removal



WARNING



INJECTION HAZARD
To reduce the risk of serious injury, when instructed to relieve pressure, follow the **Pressure Relief Procedure** on page 8.

1. **Relieve pressure.**
2. Remove screws (25, 26) and lower heat sink (22) and motor control board (22a). See Fig. 21.
3. Disconnect wires (C), (D), (96), (E) and 108 from motor control board (22a). See Fig. 13.
4. Disconnect potentiometer (77) and transducer (67) from motor control board (22a).

5. Remove four screws and motor control board (22a).
6. Install new motor control board (22a) with four screws. Reconnect all wires and secure heat sink (22) to junction box (20).

CAUTION

To reduce the risk of a malfunction:

- Be sure the flat blade of the insulated male connector is centered in the wrap-around blade of the female connector when the connections are made.
- Route all wires carefully to avoid interference with the motor control board or junction box.

Motor control board diagnostics

1. **Relieve pressure.**
2. Remove screws (25, 26) and lower heat sink (22) and motor control board (22a). See Fig. 21.
3. Turn ON/OFF switch ON.
4. Observe LED operation and reference following table:

LED BLINKS	SPRAYER OPERATION	INDICATES	WHAT TO DO
Once	Sprayer runs	Normal operation	Do nothing
Twice	Sprayer runs	Normal operation	Do nothing
Twice repeatedly	Sprayer shuts down and LED continues to blink twice repeatedly	Line voltage is too high	Lower line voltage to 120 VAC
Three times repeatedly	Sprayer shuts down and LED continues to blink three times repeatedly	Pressure transducer is faulty or missing	Replace pressure transducer
Four times repeatedly	Sprayer shuts down and LED continues to blink four times repeatedly	Run away pressure. Pressure greater than 4500 psi.	Replace motor control board. See preceding Motor control board removal procedure.
Five times repeatedly	Sprayer shuts down and LED continues to blink five times repeatedly	Locked rotor. Motor can not turn because of some mechanical condition.	Clear obstruction and replace broken parts preventing motor from turning

Power Supply Cord

WARNING



INJECTION HAZARD

To reduce the risk of serious injury, when instructed to relieve pressure, follow the **Pressure Relief Procedure** on page 8.

1. **Relieve pressure.**
2. Remove screws (25, 26) and lower heat sink (22). See Fig. 21.
3. Disconnect power supply cord leads (30), including green wire to grounding screw (78). See Fig. 13.
4. Loosen strain relief bushing (29). Remove power supply cord (30).
5. Install new cord (30) in reverse order of disassembly.
6. Install heat sink (22). Be sure no leads are pinched between heat sink and junction box (20).

On/Off Switch

WARNING



INJECTION HAZARD

To reduce the risk of serious injury, when instructed to relieve pressure, follow the **Pressure Relief Procedure** on page 8.

1. **Relieve pressure.**
2. Remove screws (25, 26) and lower heat sink (22). See Fig. 23.
3. Remove rubber boot (82). See page 32.
4. Disconnect black wires from ON/OFF switch (80) and remove switch. See Fig. 13.
5. Install switch so internal tab of anti-rotation ring (54) engages with vertical groove in threads of switch, and external tab engages with slot of junction box. See page 32.
6. Powder inside of rubber boot (82) with talcum, then shake excess out of boot. Install nut and rubber boot and tighten.
7. Reconnect ON/OFF switch black wires.
8. Install control card. Be sure no leads are pinched between motor control board or other components.

Drive Housing, Connecting Rod, Crankshaft

⚠ WARNING



INJECTION HAZARD

To reduce the risk of serious injury, when instructed to relieve pressure, follow the **Pressure Relief Procedure** on page 8.

NOTE: Inspect parts as they are removed. Replace parts that are worn or damaged.

1. **Relieve pressure.**
2. Remove displacement pump. See page 22.
3. Remove motor shield (32).
4. Lower heat sink (22) and remove pressure transducer (67). See page 28.

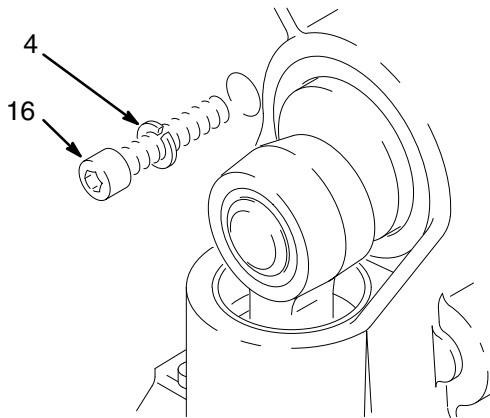

Fig. 22

7840A

5. Remove three drive housing screws and lockwashers (16, 4). Also see Fig. 23.
6. Remove two motor screws and lockwashers (3, 4). See Fig. 23.

⚠ CAUTION

Do not allow the gear (13) to fall; it may stay attached to the drive housing or to the motor.

Do not lose the thrust balls (2a or 41) or let them fall between the gears, which will damage the drive housing if not removed. The balls, which are heavily covered with grease, usually stay in the gear recesses, but could be dislodged. If the balls are not in place, the bearings will wear prematurely.

7. Tap lower rear of drive housing (2) with a plastic mallet to loosen motor. Pull drive housing straight off motor.
8. Remove and inspect crankshaft (5) and connecting rod (12). Replace all damaged or worn parts.
9. Install connecting rod.
10. Lubricate inside of connecting rod bearing with SAE non-detergent oil. Pack roller bearing and gears with grease supplied.

NOTE: The gears and bearings between the drive housing (2) and motor front end bell (C) should contain a total of 3 fl oz (89 cc) of grease.

11. Place large washer (6) and then small washer (7) on crankshaft (5).
12. Rotate crank to top of stroke and insert crankshaft (5). Align gears and push drive housing (2) straight onto motor and locating pins. Install screws (16, 3) and their lockwashers (4). Torque to 80 in-lb (9 N·m).
13. Plug in pressure transducer. See page 28.
14. Install displacement pump. See page 22.
15. Install front cover (11).
16. Replace motor shield (32).
17. Replace heat sink (22).

Drive Housing, Connecting Rod, Crankshaft

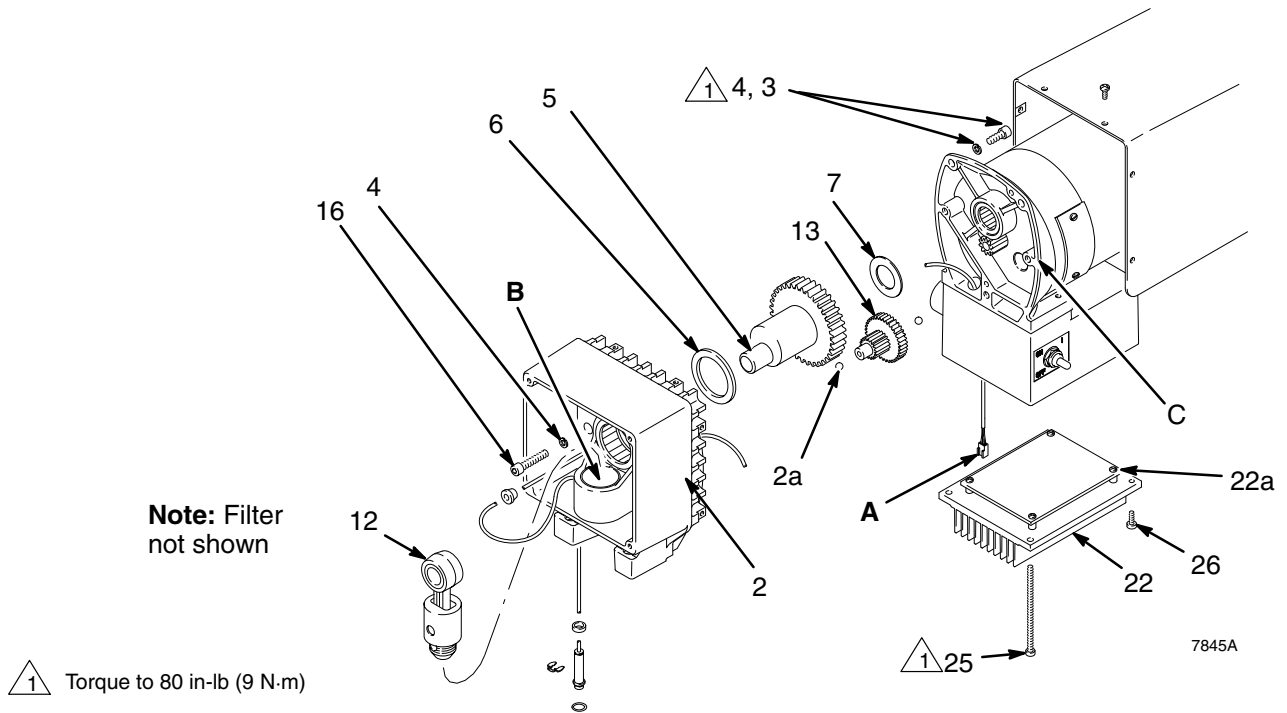

Fig. 23

7742A

Pressure Transducer

NOTE: See Fig. 23 and 24 for this procedure.

NOTE: The pressure transducer (67) cannot be repaired or adjusted. If it malfunctions, replace it.

Removal

WARNING



INJECTION HAZARD

To reduce the risk of serious injury, when instructed to relieve pressure, follow the **Pressure Relief Procedure** on page 8.

1. **Relieve pressure.**
2. Remove displacement pump (18). See page 22.
3. Remove front cover (11). Remove screws (25, 26). Lower motor control card.
4. Disconnect harness connector from motor control board (22a). Remove grommet (65).
5. Remove retaining ring (66). Pull pressure transducer down and out past drive housing (2).
6. Guide harness (A) through motor and drive housing and remove pressure transducer.
7. Inspect spacer (68) and seal (69) for damage. Replace seal (69) only if it is cut, nicked, or if leakage occurred. See page 28.

Installation

1. Using a small piece of solid copper or mild steel wire (approximately 12 in.), form a small hook and place it in the passage of bottom of the motor. Guide it up and out the hole in the drive housing.

2. Pass a spacer (68) over harness connector (A) and down into position at bottom of transducer (67).
3. Guide harness up through leg and notch of drive housing (2). Secure guide wire over connector.
4. While pulling guide wire out through bottom of motor, guide harness through drive housing and motor castings.
5. Place grommet (65) over harness and push into position in drive housing hole.
6. Feed excess harness cable through grommet and fully seat transducer body into hole in drive housing leg. Secure it with retaining ring (66).
7. Attach connector to motor control board (22a). Replace cover (11) and heat sink (22). Ensure no wires are pinched between components.

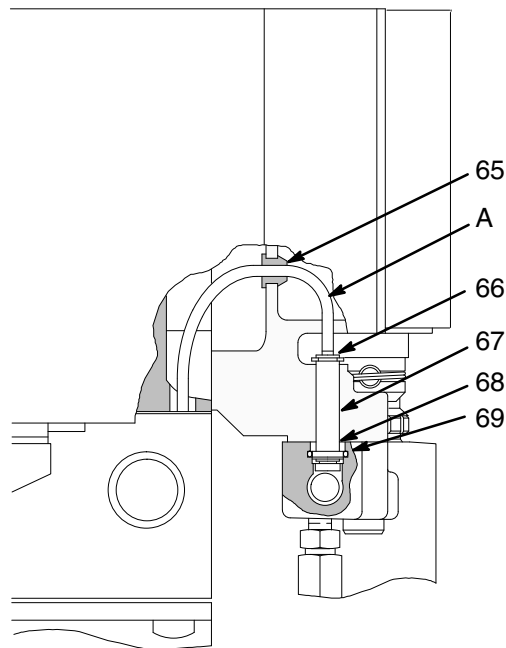

Fig. 24

02996A

Pressure Transducer Seal

NOTE: PTFE seal is unaffected by most solvents and materials. Replace seal only when leakage occurs.

Removal

WARNING



INJECTION HAZARD

To reduce the risk of serious injury, when instructed to relieve pressure, follow the **Pressure Relief Procedure** on page 8.

1. **Relieve pressure.**
2. Remove displacement pump (18). See page 22.
3. Remove seal (69) from recess in manifold (229).
4. Clean manifold recess with solvent and cloth or cotton swabs. Inspect for nicks or scratches.

Pressure Transducer Seal

Installation

1. Lightly coat cleaned packing recess in manifold with a light grease or oil.
2. Heat seal (69) in hot water for several minutes.

⚠ CAUTION
Excess pressure from the probes or fingernails will damage the packing and cause subsequent leakage.

3. Use a blunt wooden or plastic probe and install seal (69) into recess in manifold (229). Be careful not to cause kinks or bends in packing during installation.

4. Lightly grease or oil transducer (67) and install pump (18). See page 22.

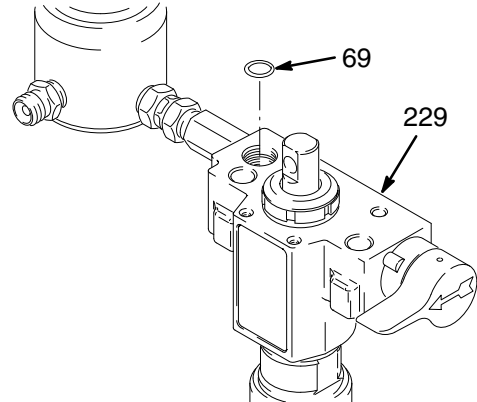



Fig. 25

7743A

Suction Hose (Model 824–132)

⚠ WARNING
 <p>INJECTION HAZARD To reduce the risk of serious injury, when instructed to relieve pressure, follow the Pressure Relief Procedure on page 8.</p>

1. **Relieve pressure.**
2. Remove drain hose (50) from clip.
3. Pull upward on suction hose (47) while unscrewing it from inlet tube (43). The hose coupling (A) threads will engage and the hose will separate from the tube.
4. Replace o-ring (45) if it is worn or damaged.
5. Lubricate o-ring (45) and inlet tube (43) threads with light grease.
6. Align suction hose coupling (A) with threads of inlet tube (43). Tighten hose onto tube at least 4 turns to ensure that threads have disengaged and can function as a swivel joint.

⚠ CAUTION
Misalignment or cross-threading will damage the parts and/or create shavings which can cause the o-ring (45) to leak.

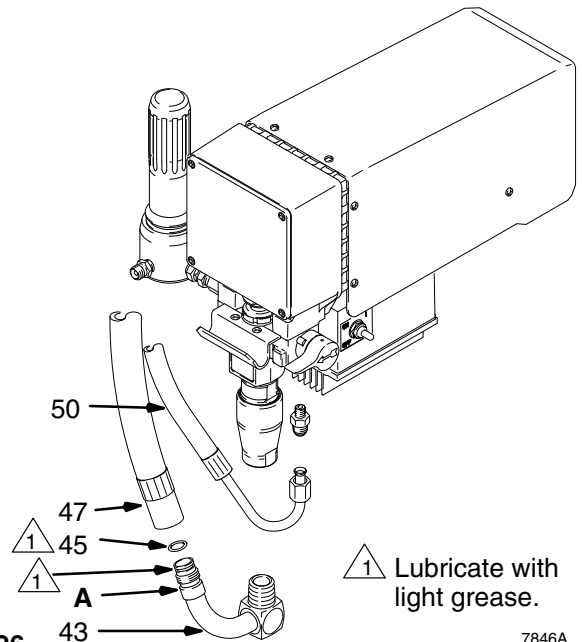

Fig. 26

7846A

Drain Valve

! WARNING



INJECTION HAZARD

To reduce the risk of serious injury, when instructed to relieve pressure, follow the **Pressure Relief Procedure** on page 8.

1. **Relieve pressure.**
2. Turn handle (54) to closed position. Drive out pin (53). Remove handle.
3. Remove base (52).
4. Unscrew drain valve assembly (51). gasket (55) and seat (56) will stay in valve.

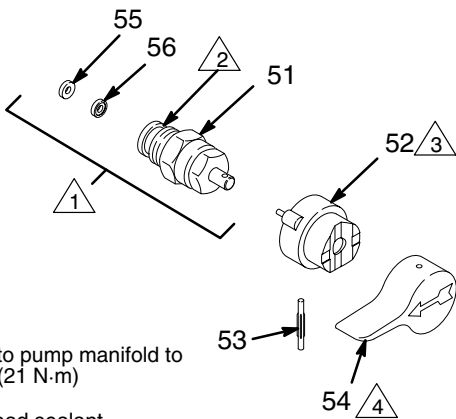

1 Torque into pump manifold to 185 in-lb (21 N·m)

2 Apply thread sealant

3 Apply grease to face of base

4 Handle shown in closed position

Fig. 27

7839A

Repair

1. Unscrew spring retainer from valve body. Remove spring, washers and stem/ball. Clean any debris from ball or seat area.
2. If replacing gasket (55) or seat (56), pry out gasket.

NOTE: Whenever gasket (55) is removed, replace it with a new one.

3. Place seat (56) in drain valve assembly (51) so lapped side is toward ball. Apply a small amount of grease to new gasket (55) and install it in drain valve assembly.

NOTE: The gasket will protrude from the end of the valve until the valve is tightened into pump, which correctly seats the gasket.

Replacement

1. Apply a small amount of thread sealant (110–110) onto drain valve assembly (51) threads. Tighten the valve into the pump manifold (229) to 185 in-lb (21 N·m).
2. Lightly grease face of base (52) and install base. Turn stem so pin hole is vertical.
3. Securely install handle (54) and drive pin (53).

Technical Data

Power Requirements 120 VAC, 60 Hz,
1 phase, 15A minimum
Generator 3000W minimum
Working Pressure Range 0–3000 psi
(0–210 bar, 21 MPa)
Motor 0.9 HP
with latex at 2000 psi (138 bar, 13.8 MPa)
Cycles/Gallon (liter) 566 (150)
Maximum Delivery Rating 0.6 gpm (2.3 lpm)
Tip Size one gun to 0.026 new tip
with latex at 2000 psi (138 bar, 13.8 MPa)
Power Cord 14 AWG, 3 wire, 15 ft (4.5 m)

Inlet Paint Strainer 16 mesh (975 micron)
Stainless Steel Screen, reusable
Outlet Filter 60 mesh (238 micron)
Pump Inlet Size 3/4 npt(f)
Fluid Outlet Size 1/4 npsm
Wetted Parts: Zinc-plated carbon steel,
Aluminum, Stainless steel,
Polyethylene, Delrin®, Leather
Tungsten carbide, Chrome plating, Polyurethane
NOTE: PTFE¹ and Delrin¹⁶

Dimensions

Model 824–132

Weight (dry w/o packaging) 61 lb (27.7 kg)
Length 25.5 in. (648 mm)
Width 15 in. (381 mm)
Height 20 in. (508 mm)

Model 824–130

Weight (dry w/o packaging) 73 lb (33.1 kg)
Length 21 in. (533 mm)
Width 20.5 in. (521 mm)
Height (Handle Down) 28.5 in. (711 mm)

Accessories

DANGER LABELS

The English language DANGER label shown on page 4 is also on your sprayer. If you have painters who do not read English, order one of the following labels to apply to your sprayer. The drawing below shows the best placement of these labels for good visibility.

Order the labels directly from Graco, free of charge:
1-800-328-0211

French	187-784
Spanish	185-956
German	185-961
Greek	186-041
Korean	186-045
English	187-791

**Apply other
language here**

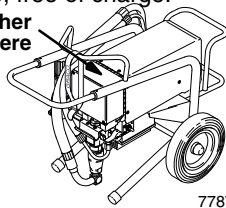

7787A

Complete Sprayer Parts

Model 824-132 Series A

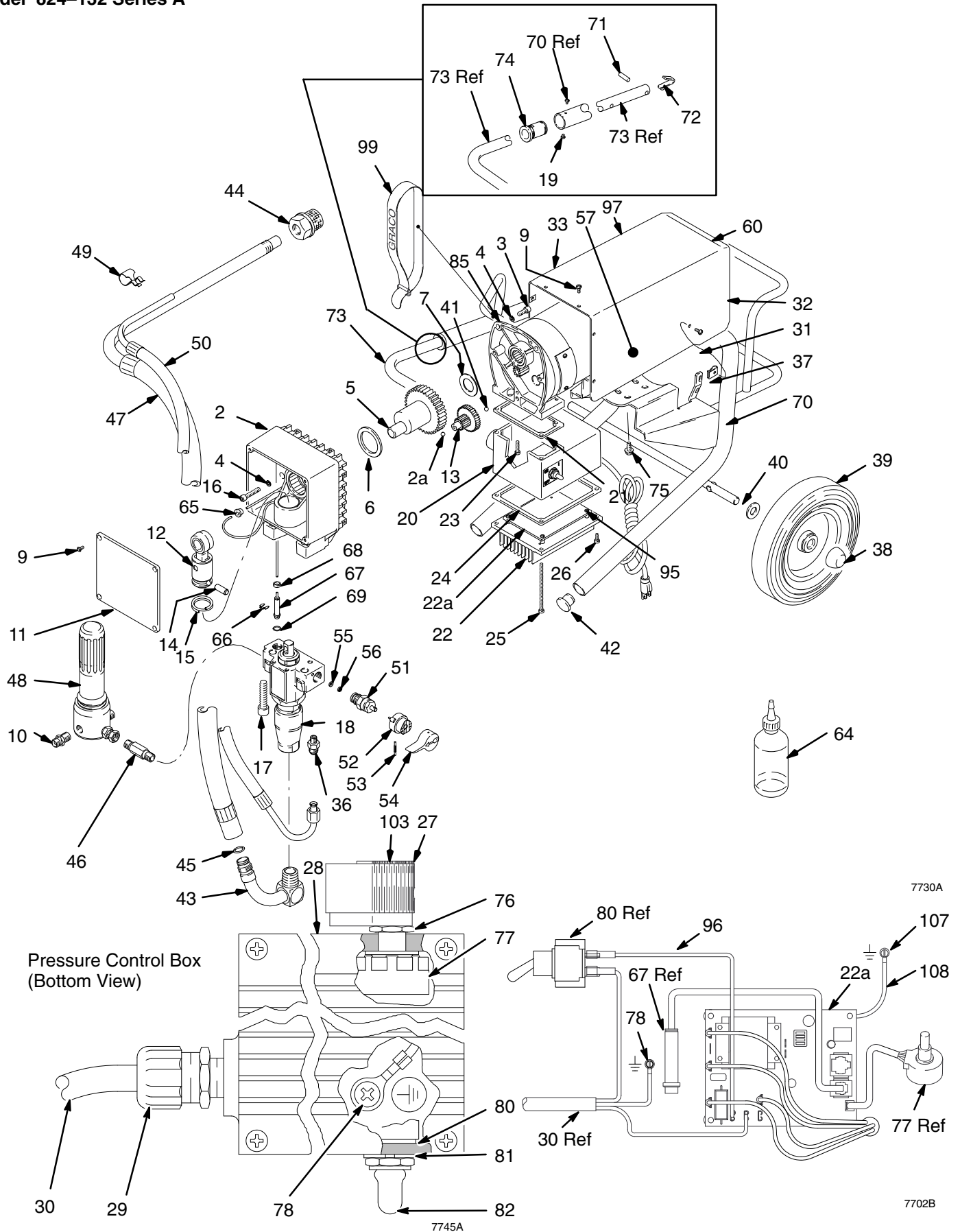

Complete Sprayer Parts

Model 824–132, Series A

Ref. No.	Part No.	Description	Qty.	Ref. No.	Part No.	Description	Qty.
2	240–133	KIT, housing, drive, Ultimate 695	1	43	192–808	TUBE, suction	1
2a	100–069	BALL, thrust	1	44	235–004	STRAINER, 1/2 npsm	1
3	101–682	SCREW, sch, 1/4–20 x .625	2	45	104–938	PACKING, o-ring	1
4	105–510	LOCKWASHER, 1/4 hi-collar	5	46	192–644	NIPPLE, long, 1/4 npt x 1/4 npsm	1
5	239–979	CRANKSHAFT, U–695	1	47	187–624	HOSE, suction, swivel	1
6	180–131	BEARING, thrust, front	1	48	240–038	FILTER, fluid	1
7	107–434	BEARING, thrust, rear	1			see manual 308–249	
9	108–865	SCREW, panh	10	49	114–026	CLIP, spring	1
10	162–453	NIPPLE, 1/4 npt x 14 npsm	1	50	238–345	HOSE, drain	1
11	192–818	COVER, front, Ultimate 695	1	51	224–806	ASSEMBLY, drain valve	1
12	240–519	CONNECTING, rod assy	1	52	224–807	VALVE, base	1
13	218–364	GEAR, assy, 2nd stage	1	53	111–600	PIN, grooved	1
14	176–818	PIN, straight	1	54	187–625	HANDLE, drain valve	1
15	176–817	SPRING, retaining	1	55	111–699	GASKET, seat valve	1
16	103–345	SCREW, sch, 1/4–20 x 1.25	3	56	187–615	SEAT, valve, lapped	1
17	111–706	SCREW, mach, sch, 7/16 x 1.75	2	57▲	187–791	LABEL, DANGER, English	2
18	239–769	KIT, pump, displacement see manual 308–815	1	60▲	187–975	LABEL, WARNING, elec shock	1
19	112–620	SCREW, 6–32 x 0.187	4	64	206–994	LIQUID, throat seal	1
20	193–130	HOUSING, junction box	1	65	114–296	GROMMET, cable	1
21	112–158	GASKET, motor	1	66	112–396	RING, external retaining	1
22	192–844	HEAT SINK, does not include 22a	1	67	240–514	TRANSDUCER, pressure control	1
22a	240–168	KIT, board, control, motor see manual 308–816	1	68	189–269	SPACER, transducer	1
23	112–379	SCREW, filh, 10–24 x 0.75	2	69	104–319	PACKING, o-ring, PTFE	1
24	112–159	GASKET, heatsink	1	70	239–999	FRAME, cart, U–695	1
25	112–381	SCREW, panh, 10–24 x 3.5	2	71	109–567	PIN, spring, straight	2
26	114–417	SCREW, panh, 8–32 x 0.5	2	72	178–565	BUTTON, spring	1
27	114–273	KNOB, potentiometer	1	73	189–934	HANDLE, cart	1
28	193–056	LABEL, pressure adjust	1	74	280–290	BUSHING, sleeve, molded	2
29	114–284	BUSHING, strain relief	1	75	110–997	SCREWS, 1/4–20 x .625	4
30	239–995	CORD, power set	1	76	112–382	NUT, shaft sealing	1
31	114–053	SCREW, trusshead, 8–32	2	77	236–352	POTENTIOMETER, pressure adj	1
32	240–486	KIT, shield, motor, Ultimate 695 includes 9, 31, & 37; 33 & 57	1	78	110–037	SCREW, sltd hex hd, 10–24 x .375	1
33▲	187–784	LABEL, DANGER, French	2	80	111–930	SWITCH, toggle	1
36	111–612	ADAPTER, tube	1	81	105–658	RING, locking	1
37	114–052	NUT, self-retaining	2	82	105–659	BOOT, toggle	1
38	112–612	CAP, hub	2	85	240–035	KIT, motor, electric, DC	1
39	112–607	WHEEL, semi-pneumatic	2	95	114–420	SCREW	4
40	109–570	WASHER, plain	2	96	240–495	WIRE, electrical, 5", (F), 18 AWG	1
41	100–069	BALL, thrust	1	97	192–838	LABEL, warning	2
42	112–759	PLUG, tube	2	99	114–271	STRAP, hose	1
				103▲	193–072	LABEL, pressure	1
				107	114–422	SCREW, pnhd	1
				108	240–498	WIRE, ground	1

▲Extra Warning Labels available free

Complete Sprayer Parts

Model 824-130, Series A

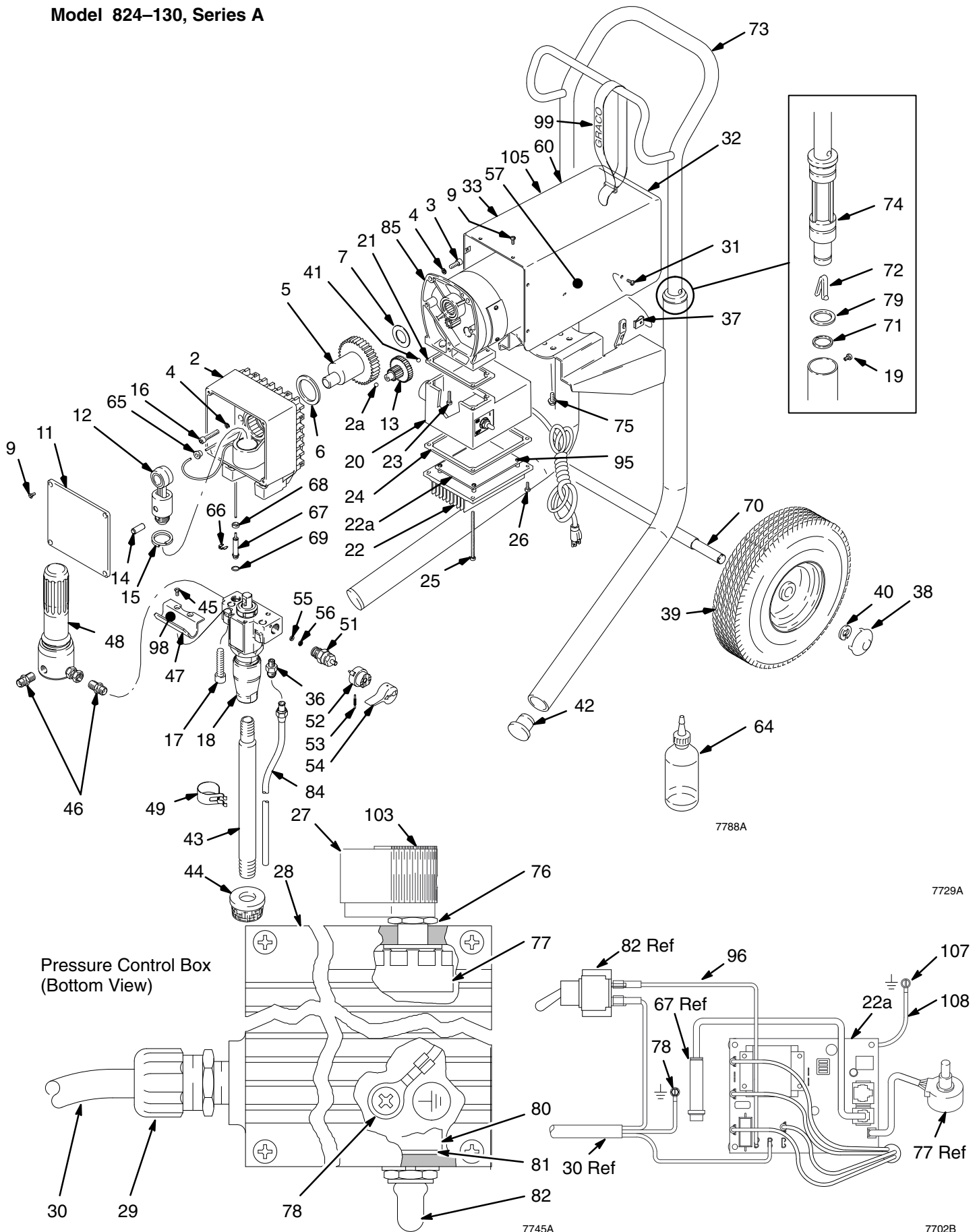

Pressure Control Box
(Bottom View)

Complete Sprayer Parts

Model 824–130, Series A

Ref. No.	Part No.	Description	Qty.	Ref. No.	Part No.	Description	Qty.
2	240–133	KIT, housing, drive, Ultimate 695	1	46	162–453	NIPPLE, 1/4 npt x 1/4 npsm	2
2a	100–069	BALL, thrust	1	47	190–321	HANGER, pail	1
3	101–682	SCREW, sch, 1/4–20 x .625	2	48	240–038	FILTER, fluid Manual 308–249	1
4	105–510	LOCKWASHER, 1/4 hi-collar	5	49	192–648	CLIP, spring	1
5	239–979	CRANKSHAFT, U–695	1	51	235–014	ASSEMBLY, drain valve includes 55 & 56	1
6	180–131	BEARING, thrust, front	1	52	224–807	VALVE, base	1
7	107–434	BEARING, thrust, rear	1	53	111–600	PIN, grooved	1
9	108–865	SCREW, panh	10	54	187–625	HANDLE, drain valve	1
11	192–818	COVER, front, Ultimate 695	1	55	111–699	GASKET, seat valve	1
12	240–519	CONNECTING, rod assy	1	56	187–615	SEAT, valve, lapped	1
13	218–364	GEAR, assy, 2nd stage	1	57▲	187–791	LABEL, DANGER, English	2
14	176–818	PIN, straight	1	60▲	187–975	LABEL, WARNING, elec shock	1
15	176–817	SPRING, retaining	1	64	206–994	LIQUID, throat seal	1
16	103–345	SCREW, sch, 1/4–20 x 1.25	3	65	114–296	GROMMET, cable	1
17	111–706	SCREW, mach, sch, 7/16 x 1.75	2	66	112–396	RING, external retaining	1
18	239–769	KIT, pump, displacement Manual 308–815	1	67	240–514	TRANSDUCER, pressure control	1
19	109–032	SCREW, 10–24 x 0.250	4	68	189–269	SPACER, transducer	1
20	193–130	HOUSING, junction box	1	69	104–319	PACKING, o-ring, PTFE	1
21	112–158	GASKET, motor	1	70	240–007	FRAME, cart, U–695	1
22	192–844	HEAT SINK, does not include 22a	1	71	110–243	RING, retaining, handle	2
22a	240–168	KIT, board, control, motor	1	72	111–590	BUTTON, spring	2
23	112–379	SCREW, filh, 10–24 x 0.75	2	73	239–998	HANDLE, cart	1
24	112–159	GASKET, heatsink	1	74	192–027	SLEEVE, cart	2
25	112–381	SCREW, panh, 10–24 x 3.5	2	75	110–997	SCREWS, 1/4–20 x .625	4
26	114–417	SCREW, panh, 8–32 x 0.5	2	76	112–382	NUT, shaft sealing	1
27	114–273	KNOB, potentiometer	1	77	236–352	POTENTIOMETER, pressure adj	1
28	193–056	LABEL, pressure adjust	1	78	110–037	SCREW, sltd hex hd, 10–24 x .375	1
29	114–284	BUSHING, strain relief	1	79	183–350	WASHER, flat	2
30	239–995	CORD, power set	1	80	111–930	SWITCH, toggle	1
31	114–053	SCREW, trusshead, 8–32	2	81	105–658	RING, locking	1
32	240–486	KIT, shield, motor, Ultimate 695 includes 9, 31, & 37; 33 & 57	1	82	105–659	BOOT, toggle	1
33▲	187–784	LABEL, DANGER, French	2	84	240–017	TUBE, drain	1
37	114–052	NUT, self-retaining	2	85	240–035	KIT, motor, electric, DC	1
38	104–811	CAP, hub	2	95	114–420	SCREW	4
39	106–062	WHEEL, semi-pneumatic	2	96	240–495	WIRE, electrical, 5", (F), 18 AWG	1
40	101–242	RING, retaining, wheel	2	98▲	192–840	LABEL, WARNING, finger pinch	1
41	100–069	BALL, thrust	1	99	114–271	STRAP, hose	1
42	108–691	PLUG, tube	2	103▲	193–072	LABEL, pressure	1
43	192–809	TUBE, suction	1	105▲	192–838	LABEL, WARNING, French	1
44	187–190	STRAINER, 1/2 npsm	1	107	114–422	SCREW, pnhd	1
45	112–777	SCREW, 8–32 x 38	2	108	240–498	WIRE, ground	1

▲Extra Warning Labels available free

Sherwin-Williams Standard Warranty

Graco warrants all equipment referenced in this document which is manufactured by Graco and bearing its name to be free from defects in material and workmanship on the date of sale by an authorized Graco distributor to the original purchaser for use. With the exception of any special, extended, or limited warranty published by Graco, Graco will, for a period of twelve months from the date of sale, repair or replace any part of the equipment determined by Graco to be defective. This warranty applies only when the equipment is installed, operated and maintained in accordance with Graco's written recommendations.

This warranty does not cover, and Graco shall not be liable for general wear and tear, or any malfunction, damage or wear caused by faulty installation, misapplication, abrasion, corrosion, inadequate or improper maintenance, negligence, accident, tampering, or substitution of non-Graco component parts. Nor shall Graco be liable for malfunction, damage or wear caused by the incompatibility of Graco equipment with structures, accessories, equipment or materials not supplied by Graco, or the improper design, manufacture, installation, operation or maintenance of structures, accessories, equipment or materials not supplied by Graco.

This warranty is conditioned upon the prepaid return of the equipment claimed to be defective to an authorized Graco distributor for verification of the claimed defect. If the claimed defect is verified, Graco will repair or replace free of charge any defective parts. The equipment will be returned to the original purchaser transportation prepaid. If inspection of the equipment does not disclose any defect in material or workmanship, repairs will be made at a reasonable charge, which charges may include the costs of parts, labor, and transportation.

THIS WARRANTY IS EXCLUSIVE, AND IS IN LIEU OF ANY OTHER WARRANTIES, EXPRESS OR IMPLIED, INCLUDING BUT NOT LIMITED TO WARRANTY OF MERCHANTABILITY OR WARRANTY OF FITNESS FOR A PARTICULAR PURPOSE.

Graco's sole obligation and buyer's sole remedy for any breach of warranty shall be as set forth above. The buyer agrees that no other remedy (including, but not limited to, incidental or consequential damages for lost profits, lost sales, injury to person or property, or any other incidental or consequential loss) shall be available. Any action for breach of warranty must be brought within two (2) years of the date of sale.

GRACO MAKES NO WARRANTY, AND DISCLAIMS ALL IMPLIED WARRANTIES OF MERCHANTABILITY AND FITNESS FOR A PARTICULAR PURPOSE, IN CONNECTION WITH ACCESSORIES, EQUIPMENT, MATERIALS OR COMPONENTS SOLD BUT NOT MANUFACTURED BY GRACO. These items sold, but not manufactured by Graco (such as electric motors, switches, hose, etc.), are subject to the warranty, if any, of their manufacturer. Graco will provide purchaser with reasonable assistance in making any claim for breach of these warranties.

In no event will Graco be liable for indirect, incidental, special or consequential damages resulting from Graco supplying equipment hereunder, or the furnishing, performance, or use of any products or other goods sold hereto, whether due to a breach of contract, breach of warranty, the negligence of Graco, or otherwise.

FOR GRACO CANADA CUSTOMERS

The parties acknowledge that they have required that the present document, as well as all documents, notices and legal proceedings entered into, given or instituted pursuant hereto or relating directly or indirectly hereto, be drawn up in English. Les parties reconnaissent avoir convenu que la rédaction du présente document sera en Anglais, ainsi que tous documents, avis et procédures judiciaires exécutés, donnés ou intentés à la suite de ou en rapport, directement ou indirectement, avec les procédures concernées.

ADDITIONAL WARRANTY COVERAGE

Graco does provide extended warranty and wear warranty for products described in the "Graco Contractor Equipment Warranty Program".

Phone Number

TO PLACE AN ORDER, contact your Graco distributor, or call this number to identify the distributor closest to you:
1-800-367-4023 Toll Free

*All written and visual data contained in this document reflects the latest product information available at the time of publication.
Graco reserves the right to make changes at any time without notice.*

The SHERWIN-WILLIAMS COMPANY, 101 PROSPECT AVENUE, CLEVELAND, OHIO 44115

PRINTED IN U.S.A. 824-135 December 1997, Revised January 1998