

## Reactor<sup>®</sup> Connect For Reactor 3 Electric Systems

3A8504E

EN

*For remotely changing system settings on Graco Reactor 3 E-20, E-30, E-XP1, and E-XP2 systems. For professional use only.*

**Models 18E132, 18E133, 18E149, 18E150, 18E242, 18E243, 18E244, 18E245**



### Important Safety Instructions

Read all warnings and instructions in this manual and in the Reactor system manual before using equipment. Save all instructions.

#### **IMPORTANT**

Prior to using Reactor Connect, you must review and accept the Terms of Use and Software License Agreement (“Terms”).

To review the Terms, install the Reactor Connect app on your mobile device. See **Setup**, page 7.

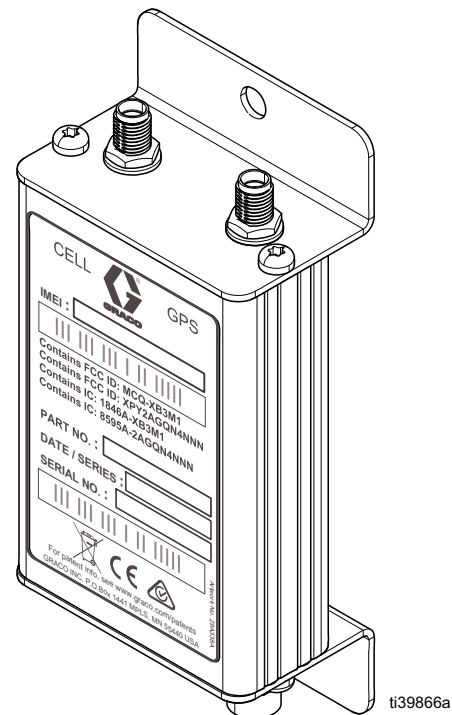

Model 25R850 show

ti39866a

# Contents

<b>Models</b> .....	<b>2</b>	<b>Cellular Screen</b> .....	<b>9</b>
<b>Agency Approvals</b> .....	<b>3</b>	View Cellular Screen .....	9
<b>Warnings</b> .....	<b>4</b>	Cellular Icons .....	9
<b>Typical Installation</b> .....	<b>5</b>	Reset Reactor Key .....	9
<b>Overview</b> .....	<b>6</b>	<b>Troubleshooting</b> .....	<b>10</b>
<b>Installation</b> .....	<b>6</b>	Disconnect Cellular Module .....	10
Mount Cellular Module .....	6	<b>Parts</b> .....	<b>11</b>
<b>Setup</b> .....	<b>7</b>	Cellular Module and Antenna .....	11
Connect App to Reactor .....	7	<b>Technical Specifications</b> .....	<b>12</b>
<b>Operation</b> .....	<b>8</b>	<b>Graco Standard Warranty</b> .....	<b>14</b>
Reactor Connect .....	8		

# Models









Kit	Cellular Module Included	Description
18E132	25R850	LTE CAT-M (4G) cellular module, only operational in the United States and Mexico
18E133	25R851	3G with 2G fallback cellular module, operational worldwide and attenuator
18E149	25F048	LTE CAT-M (4G) cellular module, operational worldwide
18E150	25F049	LTE CAT-1 (4G) cellular module, only operational in Canada
18E242	25R850	Upgrade kit contains LTE CAT-M (4G) cellular module (operational in United States and Mexico) cellular antenna, GPS antenna, and communication cable
18E243	25R851	Upgrade kit contains 3G with 2G fall back cellular module (operational in select countries worldwide), cellular antenna, GPS antenna, communication cable, and attenuator.
18E244	25F048	Upgrade kit contains LTE CAT-M (4G) cellular module (operational in select countries worldwide), cellular antenna, GPS antenna, and communications cable.
18E245	25F049	Upgrade kit contains LTE CAT-1 (4G) cellular module (operational in Canada), cellular antenna, GPS antenna, and communication cable.

# Related Manuals

Manual in English	Description
3A8500	Reactor 3 Proportioning Systems, Operation Manual
3A8501	Reactor 3 Proportioning Systems, Repair Manual

# Agency Approvals

**NOTE:** Cellular module kit 18E132 and 18E242 contains part 25R850.  
 Cellular module kit 18E133 and 18E243 contains part 25R851.  
 Cellular module kit 18E149 and 18E244 contains part 25F048.  
 Cellular module kit 18E150 and 18E245 contains part 25F049.

Description	Approvals
Module, LTE CAT-M (4G), cellular module, operational in the United States and Mexico (25R850)	See <b>Technical Specifications</b> on page 12. IFT: RTIGR2522-2656
Module, 3G with 2G fallback, cellular module, operational worldwide (25R851)	  
Module, LTE CAT-M (4G), cellular module, operational worldwide (25F048)	    R-C-CE8-25F048, R-C-ULX-SARA-R410  R003-180155
Module, LTE CAT-1 (4G), cellular module, operational in Canada (25F049)	See <b>Technical Specifications</b> on page 12.

# Warnings

The following warnings are for the setup, use, grounding, maintenance, and repair of this equipment. The exclamation point symbol alerts you to a general warning and the hazard symbols refer to procedure-specific risks. When these symbols appear in the body of this manual or on warning labels, refer back to these Warnings. Product-specific hazard symbols and warnings not covered in this section may appear throughout the body of this manual where applicable.

## DANGER

	<p><b>SEVERE ELECTRIC SHOCK HAZARD</b></p> <p>This equipment is powered by more than 240 V. Contact with this voltage will cause death or serious injury.</p> <ul style="list-style-type: none"> <li>Turn off and disconnect power at main switch before disconnecting any cables and before servicing equipment.</li> <li>This equipment must be grounded. Connect only to grounded power source.</li> <li>All electrical wiring must be done by a qualified electrician and comply with all local codes and regulations.</li> </ul>
---	---

## WARNING

	<p><b>EQUIPMENT MISUSE HAZARD</b></p> <p>Misuse can cause death or serious injury.</p> <ul style="list-style-type: none"> <li>Do not operate the unit when fatigued or under the influence of drugs or alcohol.</li> <li>Do not exceed the maximum working pressure or temperature rating of the lowest rated system component. See <b>Technical Specifications</b> in all equipment manuals.</li> <li>Use fluids and solvents that are compatible with equipment wetted parts. See <b>Technical Specifications</b> in all equipment manuals. Read fluid and solvent manufacturer's warnings. For complete information about your material, request Safety Data Sheets (SDSs) from distributor or retailer.</li> <li>Do not leave the work area while equipment is energized or under pressure.</li> <li>Turn off all equipment and follow the <b>Pressure Relief Procedure</b> when equipment is not in use.</li> <li>Check equipment daily. Repair or replace worn or damaged parts immediately with genuine manufacturer's replacement parts only.</li> <li>Do not alter or modify equipment. Alterations or modifications may void agency approvals and create safety hazards.</li> <li>Make sure all equipment is rated and approved for the environment in which you are using it.</li> <li>Use equipment only for its intended purpose. Call your distributor for information.</li> <li>Route hoses and cables away from traffic areas, sharp edges, moving parts, and hot surfaces.</li> <li>Do not kink or over bend hoses or use hoses to pull equipment.</li> <li>Keep children and animals away from work area.</li> <li>Comply with all applicable safety regulations.</li> </ul>
---	--

	<p><b>MOVING PARTS HAZARD</b></p> <p>Moving parts can pinch, cut or amputate fingers and other body parts.</p> <ul style="list-style-type: none"> <li>Keep clear of moving parts.</li> <li>Do not operate equipment with protective guards or covers removed.</li> <li>Pressurized equipment can start without warning. Before checking, moving, or servicing equipment, follow the <b>Pressure Relief Procedure</b> and disconnect all power sources.</li> </ul>
---	---

# Typical Installation

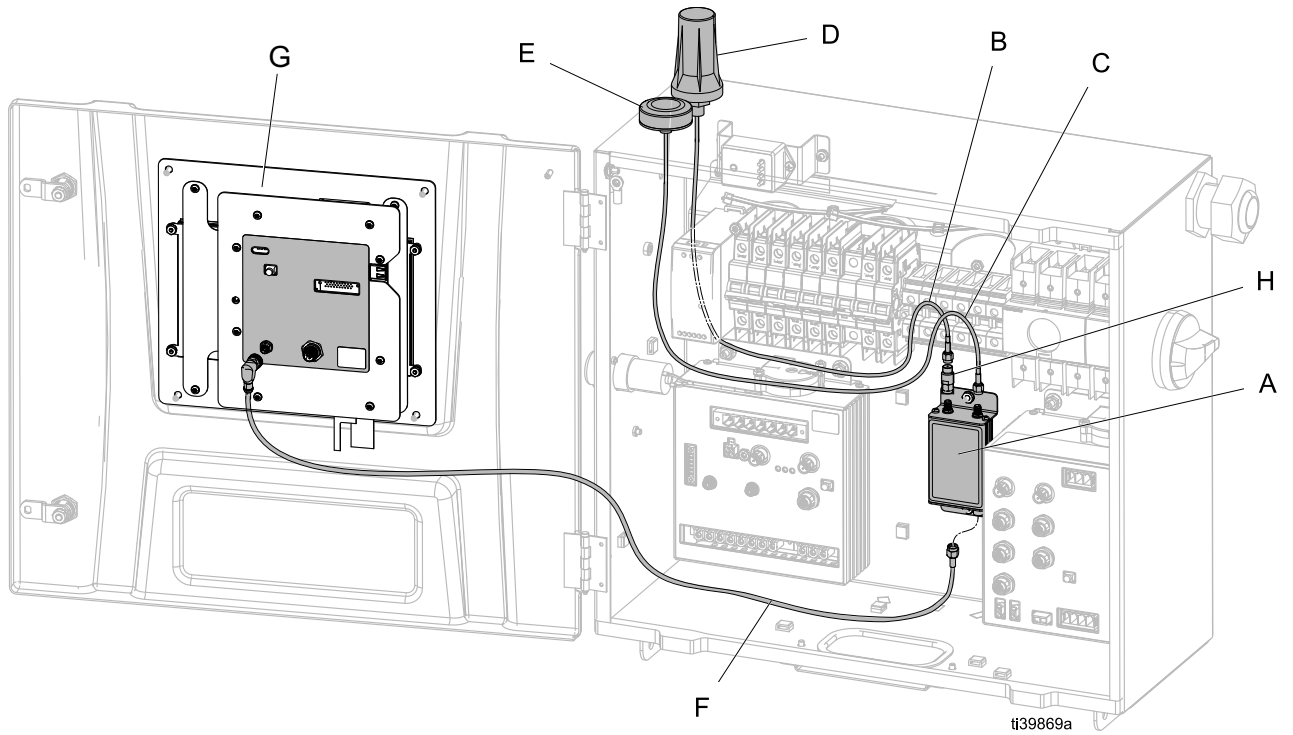

**FIG. 1: Typical Reactor Connect Cellular Module Installation**

**Ref. Description**

- A Cellular Module
- B Cellular Antenna Cable
- C GPS Antenna Cable

**Ref. Description**

- D Cellular Antenna
- E GPS Antenna
- F Serial Communication Cable
- G Advance Display Module (ADM)
- H Cellular Attenuator (18E133 and 18E243 kits only)

# Overview

--	--	--	--	--

To avoid injury due to unexpected machine operation initiated by remote controller, disconnect the cellular module from the system prior to troubleshooting. See **Disconnect Cellular Module**, page 10.

The Reactor Connect app allows the Reactor system to be monitored and operated remotely. The Reactor is intended to be controlled by an on-site operator. In any lock-out, tag-out procedure, take into consideration the potential for changes to the Reactor settings due to remote operation.

# Installation

## Mount Cellular Module

--	--	--	--	--

1. Shut down the system. See your Reactor operation manual for shutdown instructions, **Related Manuals**, page 2.
2. Disconnect incoming power at the source.
3. Unlock the top and bottom door latches and open the electrical enclosure. Review the notice.

4. Review the notice on the cardboard insert in the cellular module mounting location. When you have read and understood the terms, remove the insert.
5. Install the cellular module (A) in the center of the electrical enclosure using supplied nuts.

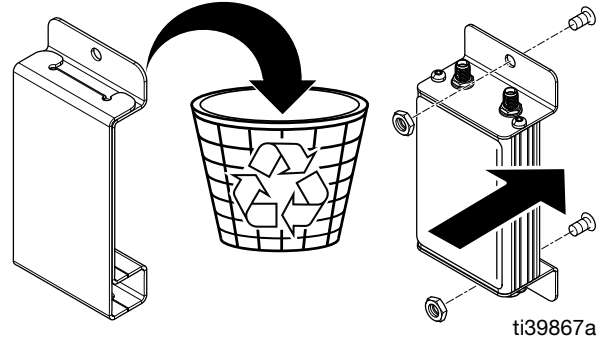

6. Install cellular and GPS antennas if necessary.
 

**NOTE:** If installing antennas make sure the GPS antenna (E) is installed with adhesive bottom against the top of the enclosure.
7. Attach the cellular antenna cable (B) to the cellular module (A). Tighten by hand.
 

**NOTE:** For 18E133 and 18E243 kits, the cellular attenuator (H) must be installed to the cellular module prior to the cellular antenna cable (B).
8. Attach the GPS antenna cable (C) to the cellular module (A). Tighten by hand.
9. Attach the serial communication cable (F) from the ADM (G) to the cellular module (A).
10. Close and lock the electrical enclosure door with the door latches.

# Setup

1. Download the Reactor Connect app from the Apple App Store<sup>®</sup> or the Android Google Play<sup>™</sup> store.
2. Open the Reactor Connect app on your smartphone. Read and agree to the Terms of Use and Software License Agreement.

## Connect App to Reactor

1. In the Reactor Connect app, tap **Add Reactor**  .
2. Follow the on-screen instructions to connect the Reactor Connect app to your Reactor system.

**NOTE:** Before connecting the Reactor Connect app to the Reactor system for the first time, **Reset Reactor Key**. See page 9.

3. If you have trouble scanning the code, type in the IMEI and the key instead.
  - a. Tap **Type in IMEI and key**.
  - b. Enter the Reactor IMEI found on the ADM Cellular screen.
  - c. Enter the Reactor key found on the ADM Cellular screen.
  - d. Tap **Connect**.

# Operation

## Reactor Connect

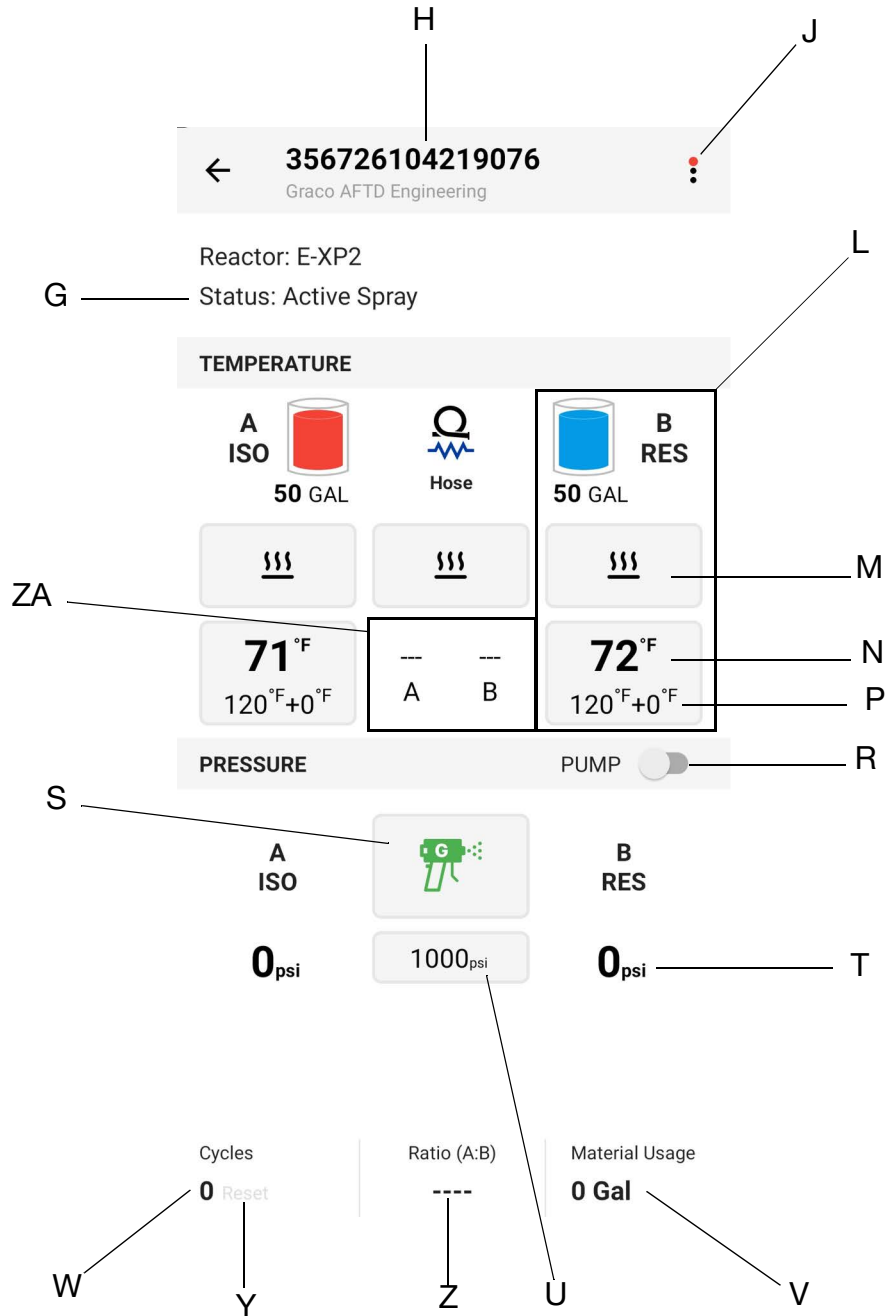

Ref.	Description
G	Reactor Status
H	Reactor Name
J	Menu
L	Heat Zone Settings
M	Heat Zone On/Off
N	Heat Zone Actual Temperature
P	Heat Zone Temperature Setpoint
R	Proportioner Start/Stop Switch

Ref.	Description
S	Proportioner Mode (Spray, Jog, Park)
T	Pump Pressure
U	Pump Pressure Setpoint
V	Material Usage
W	Cycle Count
Y	Reset Cycle Count
Z	A to B Material Ratio
ZA	Heated Hose Temperatures



# Cellular Screen



**FIG. 2: ADM Cellular Screen**



Use this screen to connect the Reactor Connect to the Reactor, view the system IMEI, or reset the Reactor Key.

## View Cellular Screen

1. On the Reactor ADM, tap . In the drop-down, go to **Advanced > Cellular**.



## Cellular Icons

Cellular notification icons are located in the menu bar of the ADM screen.

Icon	Name	Description
	Connected to Server	Cellular module detected and connected to network and server.
	GPS Location Tracking	GPS location tracking able to determine system's location.

## Reset Reactor Key

Resetting your Reactor Key prevents other users from remotely changing or viewing Reactor settings without first reconnecting to the Reactor.

1. On the Reactor ADM Cellular screen, tap  to reset the Reactor key.
2. Tap  to confirm resetting the Reactor key.
3. Reconnect your app to the Reactor. See **Connect App to Reactor**, page 7.

**NOTE:** After resetting your Reactor key, all operators using the Graco Reactor Connect must reconnect to the Reactor.

**NOTE:** For security of wireless control, change the Reactor key on a regular basis and whenever there is a concern about unauthorized access.

# Troubleshooting





For information on troubleshooting a Reactor, refer to the Reactor repair manual.

## Disconnect Cellular Module

**NOTE:** Before troubleshooting the Reactor, disconnect the cellular module (A) from the ADM. The Reactor Connect cannot change Reactor settings while the cellular module is disconnected.

1. Shut down the system. See your Reactor operation manual for shutdown instructions, **Related Manuals**, page 2.
2. Disconnect incoming power at the source.
3. Unlock and open the electrical enclosure.
4. Disconnect the serial communication cable (F) from the cellular module (A).
5. Close and lock the electrical enclosure door.

Problem	Cause	Solution
Green module status LED not illuminated.	No power to cellular module.	Turn Reactor proportioner on. Ensure cellular module is properly installed. See <b>Installation</b> , page 6.
No network connection. 	Still establishing cellular connection.	Wait a few minutes for the unit to establish a connection.
	Unable to establish cellular connection.	To establish cellular connection, move system to a location with cellular service. For 18E133 and 18E243 kits, remove cellular attenuator (H) and wait a few minutes for the unit to establish a connection.
Network is connected, but there is no server connection. 	Reactor system software is incorrect.	Go to ADM Advanced Software screen and confirm that software is correct. If it is not, update the ADM software.
	Server is not responding.	Wait a few minutes for the unit to establish a connection.

# Parts

## Cellular Module and Antenna

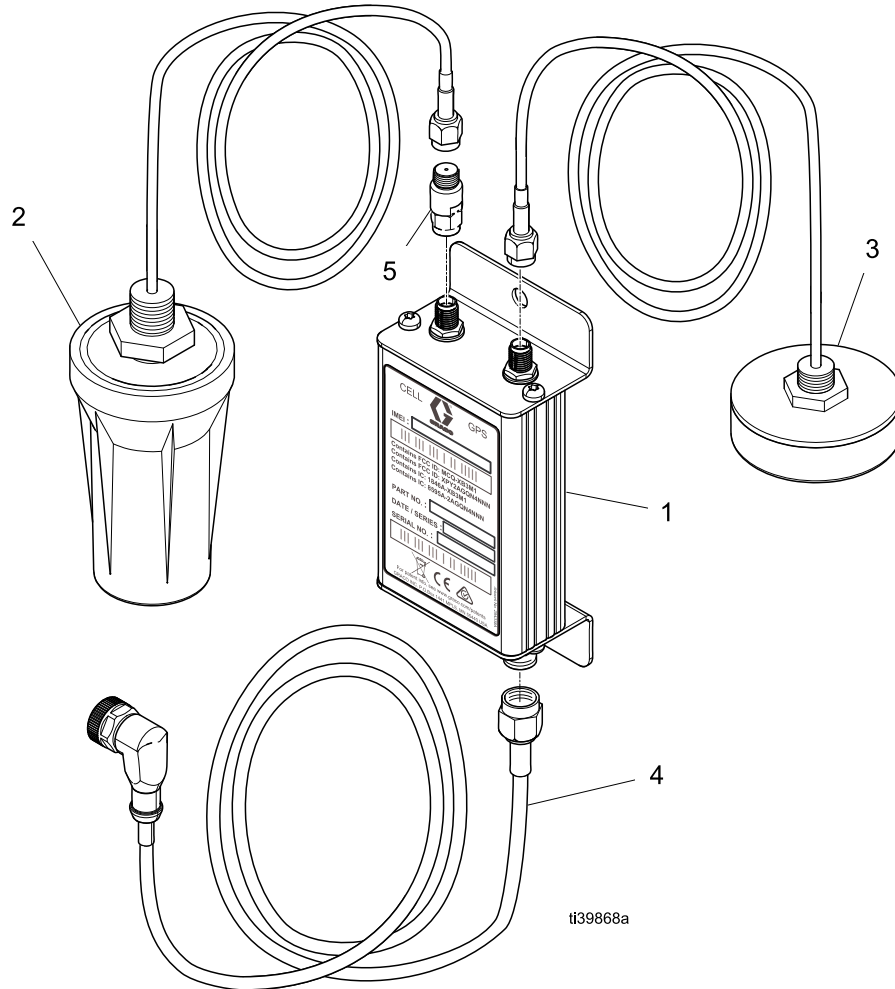

ti39868a

Ref.	Part	Description	Qty.
1	18E132	KIT, Cellular Module, CAT-M, NA	1
	18E133	KIT, Cellular Module, 3G / 2G WW	1
	18E149	Kit, Cellular Module, CAT-M, WW	1
	18E150	Kit, Cellular Module, CAT-1, Canada	1
2	18E147	ANTENNA, cellular	1
3	18E148	ANTENNA, GPS	1
4	18D295	Serial Communication Cable	1
5	133365	Cellular Attenuator (18E133 and 18E243 kits only)	1

### Upgrade Kits

- 18E242 Cellular Module, CAT-M, NA, contains 18E147, 18E148, 18D295, 18E132
- 18E243 Cellular Module, 3G / 2G WW, contains 18E147, 18E148, 18D295, 133365, 18E133
- 18E244 Cellular Module, CAT-M, WW, contains 18E147, 18E148, 18D295, 18E149
- 18E245 Cellular Module, CAT-1, Canada, contains 18E147, 18E148, 18D295, 18E150

# Technical Specifications

<b>Cellular Module (25R850 and 25F048)</b>	
<b>FCC/IC</b>	
Contains FCC ID	XPY2AGQN4NNN
Contains IC ID (Industry Canada)	8595A-2AGQN4NNN
<p>The enclosed device complies with Part 15 of the FCC Rules and with Industry Canada license-exempt RSS standard(s). Operation is subject to the following two conditions:(1) this device may not cause harmful interference and (2) this device must accept any interference received, including interference that may cause undesired operation.</p> <p>Changes or modifications not expressly approved by the party responsible for compliance could void the user's authority to operate the equipment.</p>	
<b>Cellular Radio Data</b>	
Cellular Radio	u-blox SARA-R410M-02B
Band Support	Band 12 (700 Mhz) Band 28 (700 Mhz) Band 13 (700 Mhz) Band 20 (800 Mhz) Band 26 (850 Mhz) Band 18 (850 Mhz) Band 5 (850 Mhz) Band 19 (850 Mhz) Band 8 (900 Mhz) Band 4 (1700 Mhz) Band 3 (1800 Mhz) Band 2 (1900 MHz) Band 25 (1900 MHz) Band 1 (2100 MHz) Band 39 (1900 MHz)
Power Class	Up to 23 dBm, Power Class 3
<b>GNSS Module Data</b>	
GNSS Module	u-blox MAX-M8Q-0-10
GNSS Support	GPS & GLONASS GPS GLONASS BEIDOU GALILEO
<b>Cellular Module (25R851)</b>	
<b>FCC/IC</b>	
Contains FCC ID	XPY1CGM5NNN
Contains IC ID (Industry Canada)	8595A-1CGM5NNN
<p>The enclosed device complies with Part 15 of the FCC Rules and with Industry Canada license-exempt RSS standard(s). Operation is subject to the following two conditions:(1) this device may not cause harmful interference and (2) this device must accept any interference received, including interference that may cause undesired operation.</p> <p>Changes or modifications not expressly approved by the party responsible for compliance could void the user's authority to operate the equipment.</p>	
<b>Cellular Radio Data</b>	
Cellular Radio	u-blox SARA-U201

<b>Cellular Module (25R851)</b>	
Band Support	Power Class 3 (24 dBm) for WCDMA/HSDPA/HSUPA mode Power Class 3 (24 dBm) for WCDMA/HSDPA/HSUPA mode Power Class 3 (24 dBm) for WCDMA/HSDPA/HSUPA mode Power Class 3 (24 dBm) for WCDMA/HSDPA/HSUPA mode Power Class 3 (24 dBm) for WCDMA/HSDPA/HSUPA mode
WCDMA/HSDPA/HSUPA Power Class	Power Class 3 (24 dBm) for WCDMA/HSDPA/HSUPA mode
<b>GNSS Module Data</b>	
GNSS Module	u-blox MAX-M8Q-0-10
GNSS Support	GPS & GLONASS GPS GLONASS BEIDOU GALILEO
<b>Cellular Module (25F049)</b>	
<b>FCC/IC</b>	
Contains FCC ID	MCQ-XB3C1 RI7XE866A1NA
Contains IC ID (Industry Canada)	1846A-XB3C1 5131A-XE866A1NA
<p>The enclosed device complies with Part 15 of the FCC Rules and with Industry Canada license-exempt RSS standard(s). Operation is subject to the following two conditions:(1) this device may not cause harmful interference and (2) this device must accept any interference received, including interference that may cause undesired operation.</p> <p>Changes or modifications not expressly approved by the party responsible for compliance could void the user's authority to operate the equipment.</p>	
<b>Cellular Radio Data</b>	
Cellular Radio	Telit LE866
Band Support	Band 12 (700 MHz) Band 4 (1700 MHz) Band 2 (1900 MHz)
<b>GNSS Module Data</b>	
GNSS Module	u-blox MAX-M8Q-0-10
GNSS Support	GPS & GLONASS GPS GLONASS BEIDOU GALILEO
All trademarks or registered trademarks are the property of their respective owners.	

# Graco Standard Warranty

Graco warrants all equipment referenced in this document which is manufactured by Graco and bearing its name to be free from defects in material and workmanship on the date of sale to the original purchaser for use. With the exception of any special, extended, or limited warranty published by Graco, Graco will, for a period of twelve months from the date of sale, repair or replace any part of the equipment determined by Graco to be defective. This warranty applies only when the equipment is installed, operated and maintained in accordance with Graco's written recommendations.

This warranty does not cover, and Graco shall not be liable for general wear and tear, or any malfunction, damage or wear caused by faulty installation, misapplication, abrasion, corrosion, inadequate or improper maintenance, negligence, accident, tampering, or substitution of non-Graco component parts. Nor shall Graco be liable for malfunction, damage or wear caused by the incompatibility of Graco equipment with structures, accessories, equipment or materials not supplied by Graco, or the improper design, manufacture, installation, operation or maintenance of structures, accessories, equipment or materials not supplied by Graco.

This warranty is conditioned upon the prepaid return of the equipment claimed to be defective to an authorized Graco distributor for verification of the claimed defect. If the claimed defect is verified, Graco will repair or replace free of charge any defective parts. The equipment will be returned to the original purchaser transportation prepaid. If inspection of the equipment does not disclose any defect in material or workmanship, repairs will be made at a reasonable charge, which charges may include the costs of parts, labor, and transportation.

**THIS WARRANTY IS EXCLUSIVE, AND IS IN LIEU OF ANY OTHER WARRANTIES, EXPRESS OR IMPLIED, INCLUDING BUT NOT LIMITED TO WARRANTY OF MERCHANTABILITY OR WARRANTY OF FITNESS FOR A PARTICULAR PURPOSE.**

Graco's sole obligation and buyer's sole remedy for any breach of warranty shall be as set forth above. The buyer agrees that no other remedy (including, but not limited to, incidental or consequential damages for lost profits, lost sales, injury to person or property, or any other incidental or consequential loss) shall be available. Any action for breach of warranty must be brought within two (2) years of the date of sale.

**GRACO MAKES NO WARRANTY, AND DISCLAIMS ALL IMPLIED WARRANTIES OF MERCHANTABILITY AND FITNESS FOR A PARTICULAR PURPOSE, IN CONNECTION WITH ACCESSORIES, EQUIPMENT, MATERIALS OR COMPONENTS SOLD BUT NOT MANUFACTURED BY GRACO.** These items sold, but not manufactured by Graco (such as electric motors, switches, hose, etc.), are subject to the warranty, if any, of their manufacturer. Graco will provide purchaser with reasonable assistance in making any claim for breach of these warranties.

In no event will Graco be liable for indirect, incidental, special or consequential damages resulting from Graco supplying equipment hereunder, or the furnishing, performance, or use of any products or other goods sold hereto, whether due to a breach of contract, breach of warranty, the negligence of Graco, or otherwise.

## **FOR GRACO CANADA CUSTOMERS**

The Parties acknowledge that they have required that the present document, as well as all documents, notices and legal proceedings entered into, given or instituted pursuant hereto or relating directly or indirectly hereto, be drawn up in English. Les parties reconnaissent avoir convenu que la rédaction du présente document sera en Anglais, ainsi que tous documents, avis et procédures judiciaires exécutés, donnés ou intentés, à la suite de ou en rapport, directement ou indirectement, avec les procédures concernées.

## Graco Information

For the latest information about Graco products, visit [www.graco.com](http://www.graco.com).

For patent information, see [www.graco.com/patents](http://www.graco.com/patents).

**TO PLACE AN ORDER**, contact your Graco distributor or call to identify the nearest distributor.  
**Phone:** 612-623-6921 or **Toll Free:** 1-800-328-0211 **Fax:** 612-378-3505

*All written and visual data contained in this document reflects the latest product information available at the time of publication.  
Graco reserves the right to make changes at any time without notice.*

Original instructions. This manual contains English. MM 3A8504

**Graco Headquarters:** Minneapolis

**International Offices:** Belgium, China, Japan, Korea

**GRACO INC. AND SUBSIDIARIES • P.O. BOX 1441 • MINNEAPOLIS MN 55440-1441 • USA**  
**Copyright 2021, Graco Inc. All Graco manufacturing locations are registered to ISO 9001.**

[www.graco.com](http://www.graco.com)

Revision E, June 2022